

# OPERATOR'S MANUAL

# KUBOTA TRACTOR

**MODELS**      **B1550HST**  
                         **B1750HST**

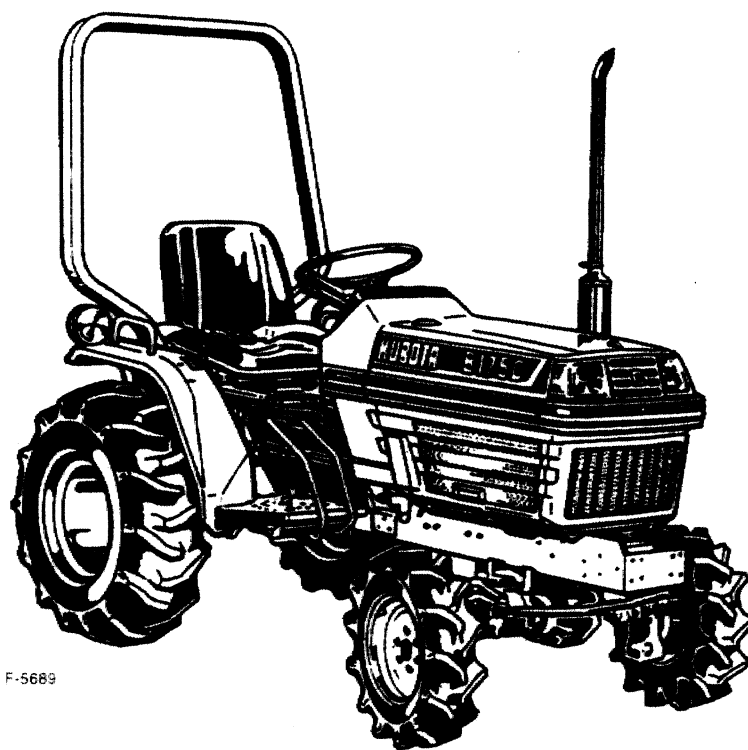

F-5689

*READ AND SAVE THIS MANUAL*

**Kubota**



# FOREWORD

You are now the proud owner of a KUBOTA Tractor. This tractor is a product of KUBOTA quality engineering and manufacturing. It is made of the finest materials and under rigid quality control system. It will give you long, satisfactory service. To obtain the best use of your tractor, please read this manual carefully. It will help you become familiar with the operation of the tractor and contains many helpful hints about tractor maintenance. It is KUBOTA's policy to utilize as quickly as possible every advance in our research. The immediate use of new techniques in the manufacture of products may cause some small parts of this manual to be outdated. KUBOTA distributors and dealers will have the most up-to-date information. Please do not hesitate to consult with them.



## SAFETY FIRST

This symbol, the industry's "Safety Alert Symbol", is used throughout this manual and on labels on the tractor itself to warn of the possibility of personal injury. Read these instructions carefully. It is essential that you read the instructions and safety regulations before you attempt to assemble or use this unit.

# CONTENTS

<b>▲ Safe Operation</b> .....	1	<b>10. Check and Maintenance</b> .....	32
<b>1. Servicing of Tractor</b> .....	6	10.1 Fuel.....	32
<b>2. Specifications</b> .....	7	10.2 Engine Oil.....	33
2.1 Specification table.....	7	10.3 Transmission Fluid.....	34
2.2 Traveling speeds.....	9	10.4 Changing Front Axle Differential Case Oil (4WD).....	35
<b>3. Implement Limitations</b> .....	10	10.5 Changing Front Axle Gear Case Oil (Right and Left) (4WD).....	36
<b>4. Operating New Tractor</b> .....	12	10.6 Steering Gear Box Oil.....	36
4.1 Loading and Unloading.....	12	10.7 Oiling and Greasing Points before Starting.....	36
<b>5. Instrument Panel and Controls</b> .....	13	10.8 Radiator.....	38
5.1 Switches.....	13	10.9 Air Cleaner.....	39
5.2 Controls.....	15	10.10 Cleaning Air Filter Element.....	39
5.3 Auxiliary Hydraulics.....	21	10.11 Battery.....	40
<b>6. Three-point Hitch &amp; Drawbar</b> .....	22	10.12 Bulb Replacement.....	41
<b>7. Wheels, Tires and Ballast</b> .....	23	<b>11 Adjustments</b> .....	42
7.1 Treads.....	24	11.1 Fan Drive Belt.....	42
7.2 Wheel Hub.....	25	11.2 Clutch.....	42
7.3 Tires.....	25	11.3 Brake.....	43
7.4 Ballast.....	25	11.4 Steering Wheel.....	43
7.5 Toe-in.....	26	<b>12. Troubleshooting</b> .....	44
<b>8. Operating Instructions</b> .....	27	12.1 Engine Troubleshooting.....	44
8.1 Operating the Engine.....	27	12.2 Tractor Troubleshooting.....	45
8.2 Operating the Tractor.....	27	12.3 Battery Troubleshooting.....	
8.3 Pulling.....	28	<b>13. Long-Term Storage</b> .....	46
8.4 Check During Driving.....	28	<b>14. Options</b> .....	47
8.5 Directions for Operating.....	29	<b>15. Lubricant specifications</b> .....	48
<b>9. Maintenance</b> .....	30	<b>16. Wiring Diagram</b> .....	49
9.1 Daily Check.....	30	<b>INDEX</b>	
9.2 Lubricants.....	30		
9.3 Maintenance Check List.....	31		



# SAFE OPERATION

Careful operation is your best insurance against an accident. Read this section carefully before operating the tractor. All operators, no matter how much experience they may have had, should read this and other related manuals before operating tractor or any implement attached to it. It is the owner's legal obligation to instruct all operators in safe operation.

## 1. BEFORE OPERATING THE TRACTOR

- (1) Know your equipment and its limitations. Read this entire manual before attempting to start and operate the tractor.
- (2) Pay special attention to the warning and caution labels on the tractor itself.
- (3) Kubota recommends the use of a Roll Over Protective Structures (ROPS) and seat belt in almost all applications. This combination will reduce the risk of serious injury or death, should the tractor be upset. If the ROPS is loosened or removed for any reason, make sure that all parts are reinstalled correctly before operating the tractor. Never modify or repair a ROPS because welding, bending, drilling, grinding, or cutting any portion may weaken the structure. A damaged ROPS structure must be replaced, not repaired or revised. If any structural member of the ROPS is damaged, replace the entire structure at your local Kubota dealer.

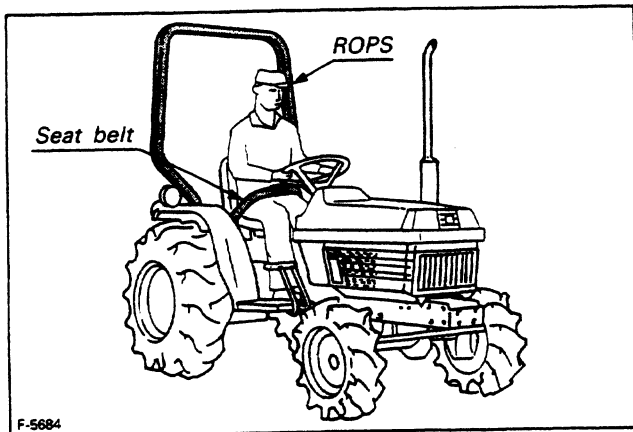

- (4) Always use the seat belt if the tractor has a ROPS. Do not use it if there is no ROPS. Check the seat belt daily and replace if frayed or damaged.
- (5) Do not operate tractor or any implement attached to it while under the influence of alcohol, medication, or other substances or while fatigued.
- (6) Carefully check the vicinity before operating tractor or any implement attached to it. Check for overhead clearance which may interfere with a ROPS. Do not allow any bystanders around or near tractor during operation.

- (7) Before allowing other people to use your tractor, explain how to operate and have them read this manual before operation.
- (8) Never wear loose, torn, or bulky clothing around tractor. It may catch on moving parts or controls, leading to the risk of accident. Use additional safety items.....hard hat, safety boots or shoes, eye and hearing protection, gloves, etc.....as appropriate or required.
- (9) Do not allow passengers or non-qualified operators on the tractor at any time. The operator must remain in the tractor seat throughout operation.
- (10) Check brakes, clutch, and other mechanical parts for faulty adjustment and wear. Replace worn or damaged parts promptly. Check the tightness of all nuts and bolts regularly. (For further details, see MAINTENANCE AND ADJUSTMENTS.)
- (11) Keep your tractor clean. Dirt, grease, and trash accumulations contribute to fires and lead to personal injury.
- (12) Use only implements meeting the specifications listed under IMPLEMENT LIMITATIONS in this manual. Use proper weights to front or rear of tractor to reduce the risk of upsets. Follow the safe operating procedures specified in the manuals included with the equipment.
- (13) The narrower the tread, the greater the risk of a tractor upset. For maximum stability, adjust the wheels to the largest practical tread width. (See page 24).

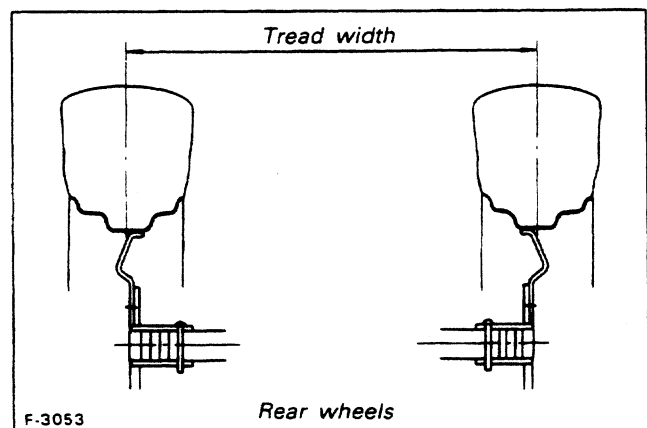

## 2. OPERATING THE TRACTOR

- (1) Never start engine or operate levers from anywhere other than the seat.
- (2) Before starting the engine, make sure that all levers (including auxiliary control levers) are in their neutral positions, that the parking brake is engaged, and that both the clutch and the Power Take-Off (PTO) are disengaged.  
Fasten the seat belt if the tractor has a ROPS.
- (3) Do not start engine by shorting across starter terminals or bypassing the safety start switch. Machine may start in gear and move if normal starting circuitry is bypassed.
- (4) Pull only from the drawbar. Never hitch to axle housing or any other point except drawbar; such arrangements only increase the risk of serious personal injury or death due to a tractor upset. (fixed or swinging type)

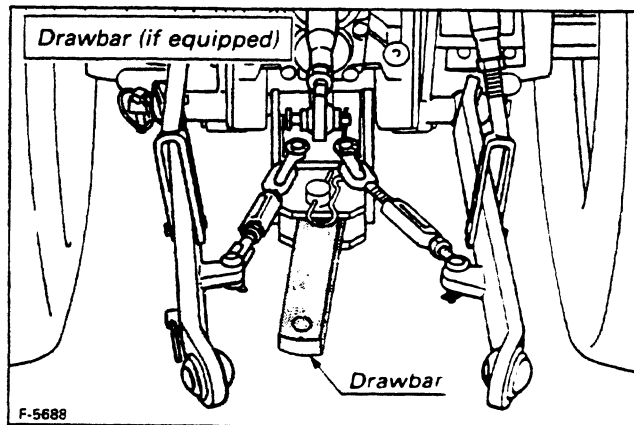

- (5) Do not operate or idle engine in a non-ventilated area. Carbon monoxide gas is colorless, odorless, and deadly.
- (6) Keep all shields and guards in place. Replace any that are missing or damaged.
- (7) Avoid sudden starts. To avoid upsets, slow down when turning, on uneven terrain, and before stopping.
- (8) The tractor cannot turn with the differential locked and attempting to do so could be dangerous.
- (9) Do not operate near ditches, holes, embankments, or other terrain features which may collapse under the tractor's weight. The risk of tractor upset is even higher when the ground is loose or wet.
- (10) Driving forward out of a ditch or mire or up a steep slope risks a tractor upset backward. Always back out of these situations. Extra caution is required with fourwheel drive models because their higher traction can give the operator false confidence in the tractor's ability to climb slopes.
- (11) To avoid upsets, always back up steep slopes. Stay off hills and slopes too steep for safe operation.
- (12) Watch where you are going at all times. Watch for and avoid obstacles. Be alert at row ends, near trees, and other obstructions.

- (13) When working in groups, always let the others know what you are going to do before you do it.
- (14) Never "freewheel". Disengaging the clutch or shift into neutral while descending a slope could lead to a loss of control.
- (15) Never try to get on or off a moving tractor.
- (16) Do not use "Bi-speed Turn" at high speed.
- (17) "Bi-speed Turn" enables short fast turns, therefore, become familiar with its performance before operating in close or confined areas.

## 3. DRIVING THE TRACTOR ON THE ROAD

- (1) Lock the two brake pedals together to help assure straightline stops. Uneven braking at road speeds could cause the tractor to roll over.

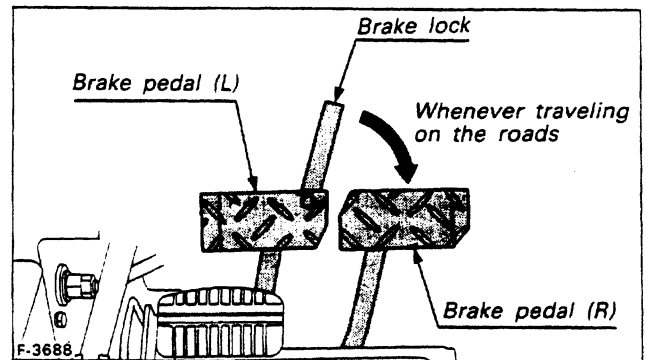

- (2) Always slow the tractor down before turning. Turning at high speed may tip the tractor over.
- (3) Make sure that the Slow-Moving Vehicle (SMV) emblem is clean and visible. Use hazard lights as required.

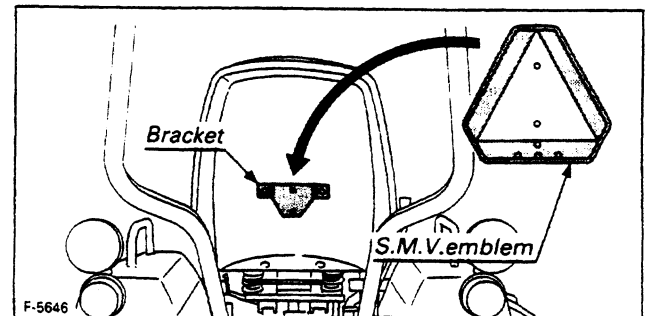

- (4) Observe all local traffic and safety regulations.
- (5) Turn the headlights on. Dim them when meeting another vehicle.
- (6) Drive at speeds that allow you to maintain control at all times.
- (7) Do not apply the differential lock while traveling at road speeds. The tractor may run out of control.
- (8) Avoid sudden motions of the steering wheel as they can lead to a dangerous loss of stability. The risk is especially great when the tractor is traveling at road speeds.
- (9) Do not operate an implement while the tractor is on road. Lock it in the raised position.
- (10) When towing other equipment, use a safety chain and place an SMV emblem on it as well.

#### 4. STOPPING THE TRACTOR

- (1) Disengage the PTO, lower all implements, place all control levers in their neutral positions, apply parking brake, turn off the engine, and remove the key.
- (2) Make sure that the tractor has come to a complete stop before dismounting.

#### 5. OPERATING THE PTO

- (1) Wait until all moving components have completely stopped before getting off the tractor, connecting, disconnecting, adjusting, cleaning, or servicing any PTO driven equipment.
- (2) Keep the PTO shaft cover in place at all times. Replace the PTO shaft cap when the shaft is not in use.

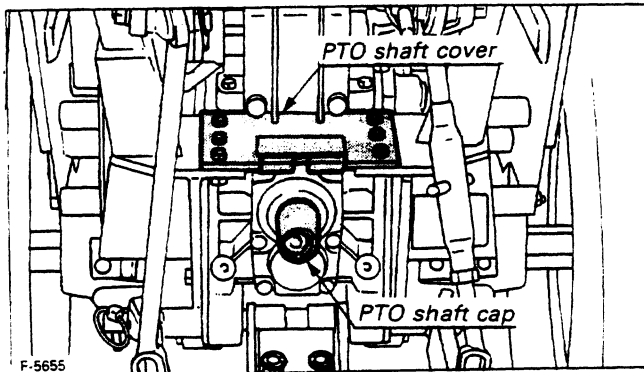

- (3) Before installing or using PTO driven equipment, read the manufacturer's manual and review the safety labels attached to the equipment.
- (4) To prevent PTO driven equipment from racing out of control, stick to the lower (Rear:540rpm) speed unless the higher (Rear:858rpm, Mid:2455rpm) one is specifically recommended as safe by the equipment manufacturer.

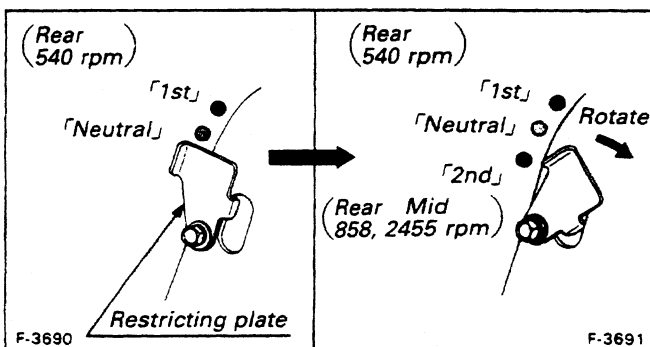
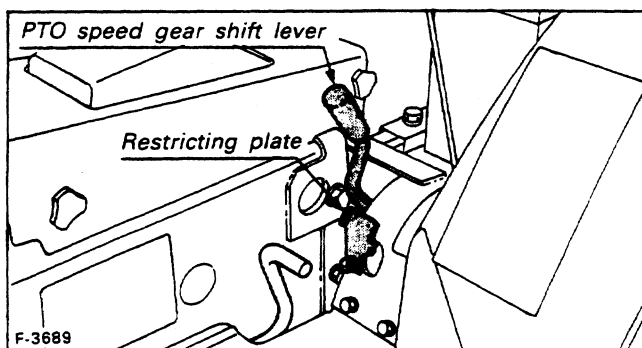

- (5) When operating stationary PTO driven equipment, always apply the tractor parking brake and place chocks behind and in front of the rear wheels. Stay clear of all rotating parts.

#### 6. USING 3-POINT HITCH

- (1) Use the 3-point hitch only with equipment designed for 3-point hitch usage.

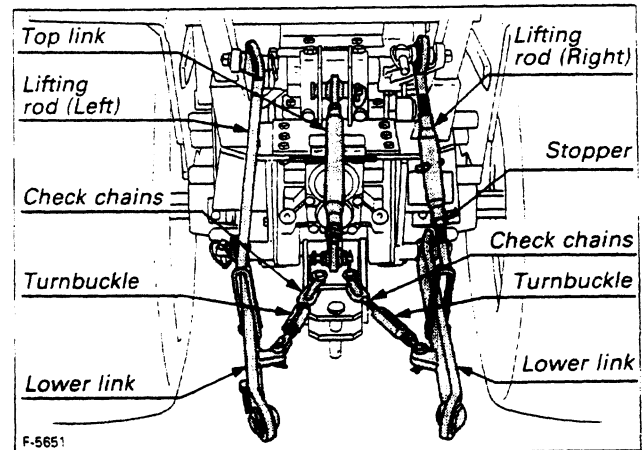

- (2) When using a 3-point hitch mounted implement, be sure to install the proper counterballast weight on the front of the tractor.
- (3) When transporting on the road, set the implement lowering control in the "lock" position to hold the implement in the raised position.

#### 7. SERVICING THE TRACTOR

Before servicing the tractor, park it on a firm level surface, set the parking brake, place the gear shift lever in neutral and stop the engine.

- (1) Allow the tractor time to cool off before working on or near the engine, muffler, radiator, etc.
- (2) Always stop the engine before refueling. Avoid spills and overfilling.
- (3) Do not smoke when working around battery or when refueling. Keep all sparks and flames away from battery and fuel tank. The battery presents an explosion hazard because it gives off hydrogen and oxygen....especially when recharging.
- (4) Before "jumping" a dead battery, read and follow all of the instructions. (See page 4)
- (5) Keep first aid kit and fire extinguisher handy at all times.
- (6) Do not remove radiator cap while coolant is hot. When cool, slowly rotate cap to the first stop and allow sufficient time for excess pressure to escape before removing the cap completely. If the tractor has a coolant recovery tank, add coolant there instead of to the radiator.

- (7) Disconnect the battery's ground cable before working on or near electric components.
- (8) To avoid sparks from an accidental short circuit, always disconnect the battery's ground cable  $\ominus$  first and connect it last.

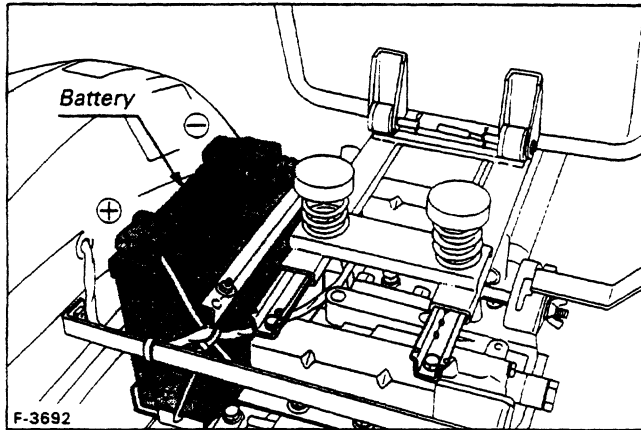

- (9) Do not attempt to mount a tire on a rim unless qualified to do so and all proper safety precautions are followed.
- (10) Provide adequate support when changing wheels or the wheel tread width.
- (11) Make sure that wheel bolts have been tightened to the specified torque.
- (12) Escaping hydraulic fluid under pressure has sufficient force to penetrate skin, causing serious personal injury. Before disconnecting hydraulic lines, be sure to release all residual pressure. Before applying pressure to the hydraulic system, make sure that all connections are tight and that all lines, pipes, and hoses are free of damage.

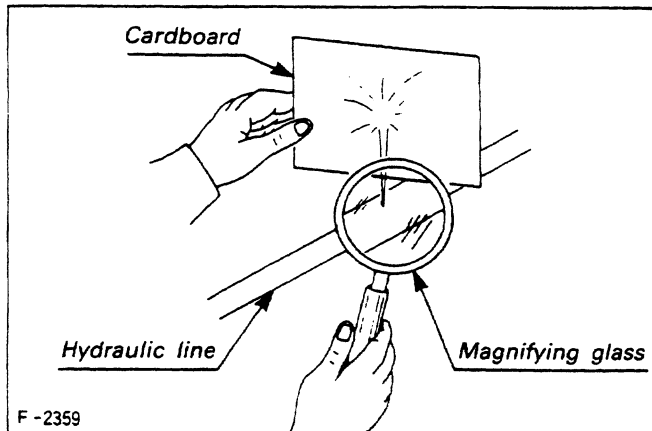

Fluid escaping from pinholes may be invisible. Do not use hands to search for suspected leaks; Use a piece of cardboard or wood, instead. Use of safety goggles or other eye protection is also highly recommended. If injured by escaping fluid, see a medical doctor at once. This fluid can produce gangrene or severe allergic reaction.

## 8. JUMP STARTING INSTRUCTIONS AND PRECAUTIONS

If ice is present or the battery is cracked, DO NOT ATTEMPT TO "JUMP START" vehicle.

- (1) Bring helper vehicle with a battery of the same voltage as disabled tractor within easy cable reach. "THE VEHICLES MUST NOT TOUCH".
- (2) Engage the parking brakes of both vehicles and put the shift levers in neutral. Turn both key switches off.
- (3) Put on safety goggles and rubber gloves.
- (4) Remove the vent caps from both batteries.
- (5) Cover vent holes with damp rags. Do not allow the rag to touch the battery terminals.
- (6) Attach the red clamp to the positive (red,  $\oplus$  or pos.) terminal of the dead battery and clamp the other end of the same cable to the positive (red,  $\oplus$  or pos.) terminal of the helper battery.
- (7) Clamp the other cable to the negative (black,  $\ominus$  or neg.) terminal of the helper battery.
- (8) Clamp the other end to the engine block or frame of the disabled tractor as far from the dead battery as possible.
- (9) Start the helper vehicle and let its engine run for a few moments. Start the disabled tractor.
- (10) Disconnect the jumper cables in the exact reverse order of attachment. (Steps 8, 7 and 6).
- (11) Remove and discard the damp rags. Reinstall the vent caps.

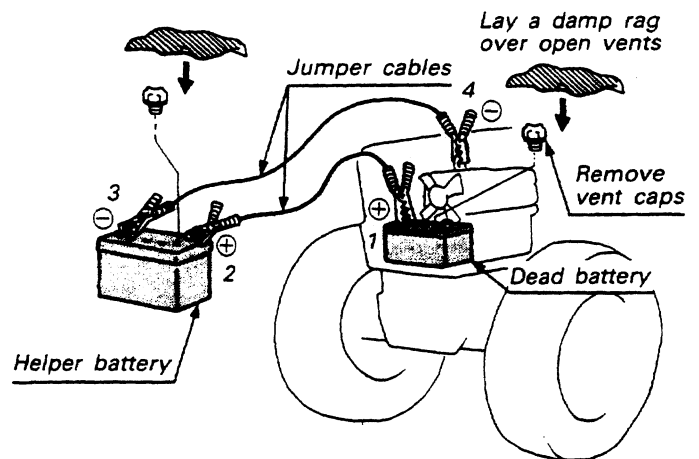

Connect cables in numerical order.  
Disconnect in reverse order after use.

F-4727



## 9. WARNING AND CAUTION LABELS

### ① Part No. 35260—3491—3

#### CAUTION

TO AVOID PERSONAL INJURY:

1. Read and understand the operator's manual before operation.
2. Before starting the engine, make sure that everyone is at a safe distance from the tractor and that the PTO is OFF.
3. Do not allow passengers on the tractor at any time.
4. Before allowing other people to use the tractor, have them read the operator's manual.
5. Check the tightness of all nuts and bolts regularly.
6. Keep all shields in place and stay away from all moving parts.
7. Lock the two brake pedals together before driving on the road.
8. Slow down for turns, or rough roads, or when applying individual brakes.
9. On public roads use SMV emblem and hazard lights, if required by local traffic and safety regulation.
10. Pull only from the drawbar.
11. Before dismounting, lower the implement, set the parking brake, stop the engine and remove the key.

### ⑤ Part No. 35820—9863—2

#### WARNING

AVOID POSSIBLE INJURY OR DEATH FROM A MACHINE RUNAWAY.

1. Do not start engine by shorting across starter terminals or bypassing the safety start switch. Machine may start in gear and move if normal starting circuitry bypassed.
2. Start engine only from operator's seat with transmission and PTO in neutral. Never start engine while standing on ground.

### ④ Part No. 35200—2534—1

#### WARNING

TO AVOID PERSONAL INJURY:

1. Keep PTO shield in place at all times.
2. Do not operate the PTO at speeds faster than the speed recommended by the implement manufacturer.

### ⑥ Part No. 67061—4724—2

#### WARNING

Do not start engine with speed set lever or speed control pedal engaged.

### ② Part No. 35260—2979—1

#### WARNING

TO AVOID PERSONAL INJURY:

1. Attach pulled or towed loads to the drawbar only.
2. Use the 3-point hitch only with equipment designed for 3-point hitch usage.

### ③ Part No. 35260—2978—2

#### WARNING

TO AVOID PERSONAL INJURY OR DEATH FROM ROLL-OVER:

1. Kubota recommends the use of a Roll-Over Protective Structures (ROPS) and seat belt in almost all applications.
2. Remove the ROPS only when it substantially interferes with operation or itself presents a safety risk. (Examples include work in orchards and vineyards.)  
ALWAYS REINSTRALL IT BEFORE USING THE TRACTOR IN OTHER APPLICATIONS.
3. Never use just the seat belt or just the ROPS. They must be used together. For further details, consult your Operator's Manual or your local dealer.

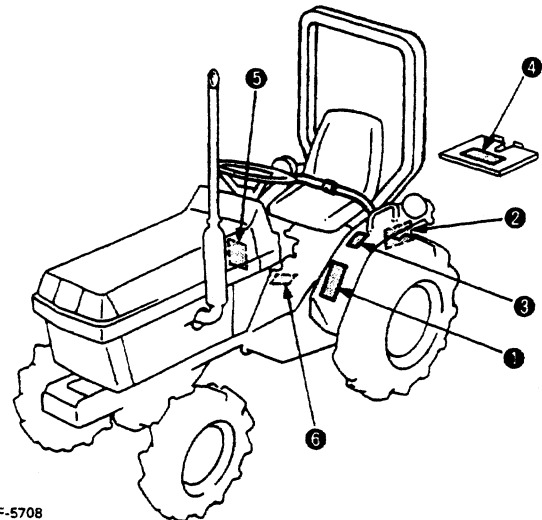

F-5708

## CARE OF WARNING AND CAUTION LABELS

- (1) Keep warning and caution labels clean and free from obstructing material.
- (2) Clean warning and caution labels with soap and water, dry with a soft cloth.
- (3) Replace damaged or missing warning and caution labels with new labels from your Kubota dealer.
- (4) If component with warning and caution label (s) affixed is replaced with new part, make sure new label(s) is (are) attached in the same location (s) as the replaced component.
- (5) Mount new warning and caution labels by applying on a clean dry surface and pressing any bubbles to outside edge.

# 1. SERVICING OF TRACTOR

Your dealer is interested in your new tractor and has the wants to help you get the most value from it. After reading this manual thoroughly, you will find that you can do some of the regular maintenance yourself.

When in need of parts or major service, however, be sure to see your KUBOTA dealer.

For service, contact the KUBOTA Dealership from which you purchased your tractor or your local authorized KUBOTA dealer.

When in need of parts, be prepared to give your dealer both the tractor and engine serial numbers.

The tractor serial number is located on the transmission housing on the left-hand side of the tractor. The engine serial number is located on the engine crankcase, right side. Locate the serial numbers now and record them in the space provided.

**KUBOTA B1550HSE (2WD)/B1550HSD (4WD)**  
**B1750HSE (2WD)/B1750HSD (4WD)**

	Type	Serial No.
Tractor	_____	_____
Engine	_____	_____
Date of Purchase	_____	_____

(To be filled in by purchaser)

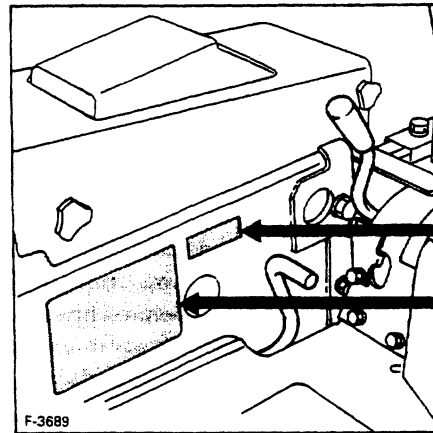

Tractor  
serial number

Identification  
plate

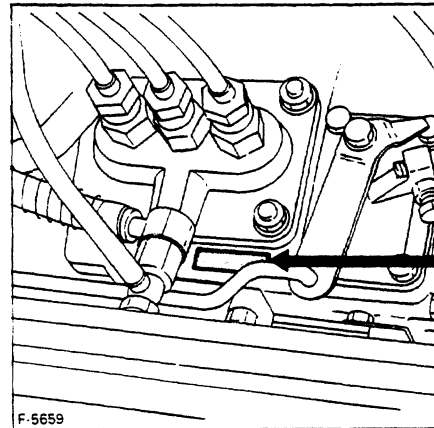

Engine  
serial number

# 2. SPECIFICATIONS

## 2.1 SPECIFICATION TABLE

Model		B1550HSE (2WD)				B1550HSD (4WD)			
Engine gross power		12.7 kW (17 HP)*							
PTO power		9.7 kW (13 HP)*							
Engine	Model	D850-5B							
	Type	Vertical, water-cooled, 4-cycle diesel							
	No. of cylinders	3							
	Bore and stroke	72 mm × 70 mm (2.8 in. × 2.7 in.)							
	Total displacement	855 cm <sup>3</sup> (52.2 cu.in.)							
	Rated revolution	43.3 r/s (2600 rpm)							
	Fuel	Diesel fuel No. 2-D [No.1 diesel fuel if temperature is below -10°C (14°F)]							
	Starter	Electric starter with battery, glow plug and decompression device, 12V, 0.8 kW							
	Lubrication	Forced lubrication by trochoidal pump							
	Cooling	Water with pressurized radiator							
Battery		12V (45 AH)							
Capacities	Fuel tank	18 ℓ (4.8 U.S.gals)							
	Engine crankcase	3.1 ℓ (3.3 U.S.qts.)							
	Engine coolant	2.9 ℓ (3.1 U.S.qts.)							
	Transmission case	13.5 ℓ (14.3 U.S.qts.)							
	Steering gear box	0.2 ℓ (0.2 U.S.qt.)							
	Front axle diff. case	—				0.5 ℓ (0.5 U.S.qt.) Bi-speed Turn: 2.5 ℓ (2.6 U.S.qts.)			
Front axle gear case		—				0.15 ℓ (0.15 U.S.qt.)			
Tires	Front	Farm 4.50-10	Farm 5.00-10	Turf 18×9.50-8	Turf 18×9.50-8	Farm 6-12B	Turf 20.5×8.00-10	Turf 20.5×8.00-10	
	Rear	7-16	8-16	29×12.00-15	31×13.5-15**	8-16	29×12.00-15	31×13.5-15**	
Dimensions	Overall length	mm (in.)	2565 (101.0)	2565 (101.0)	2565 (101.0)	2565 (101.0)	2565 (101.0)	2565 (101.0)	
	Overall width	mm (in.)	910 (35.8)	990 (39.0)	1140 (44.9)	1240 (48.8)	980 (38.6)	1140 (44.9)	1240 (48.8)
		mm (in.)	960 (37.8)	1110 (43.7)			1110 (43.7)		
	Overall height with ROPS	mm (in.)	1875 (73.7)	1900 (74.8)	1880 (74.1)	1890 (74.4)	1900 (74.8)	1880 (74.1)	1890 (74.4)
	Wheelbase	mm (in.)	1470 (57.9)	1470 (57.9)	1470 (57.9)	1470 (57.9)	1470 (57.9)	1470 (57.9)	1470 (57.9)
	Min. ground clearance	mm (in.)	230 (9.1)	255 (10.0)	240 (9.4)	250 (9.8)	240 (9.4)	215 (8.5)	215 (8.5)
		mm (in.)	710 (28.0)	710 (28.0)	850 (33.5)	850 (33.5)	795 (31.3)	825 (32.5)	895 (35.2)
Treads	mm (in.)	790 (31.1)	790 (31.1)	840 (33.1)	895 (35.2)	790 (31.1)	840 (33.1)	895 (35.2)	
	mm (in.)	910 (35.8)	910 (35.8)			910 (35.8)			
Weight (with ROPS)		kg (lbs.)	560 (1235)	570 (1257)	580 (1279)	570 (1257)	625 (1378)	630 (1389)	
Transmission case rear (rear PTO), Transmission case bottom (mid PTO) and engine front (front PTO)									
PTO shaft	SAE 1-3/8								
	Rear PTO	2 speeds (9.0 and 14.3 r/s at 41.9 engine r/s) (540 and 858 rpm at 2517 engine rpm)							
Mid PTO	USA No.5 (KUBOTA 10 tooth) Involute spline								
	1 speeds (40.9 r/s at 41.9 engine r/s) (2455 rpm at 2517 engine rpm)								
Clutch		Dry single plate							
Steering		Recirculating ball type manual steering or integral type power steering (if equipped)							
Transmission		Main-hydrostatic transmission, High-Low gear shift (2 forward, 2 reverse)							
Min. turning radius m (ft)	with Brake	2.10 (6.9)				2.40 (7.9)		Bi-speed Turn: 2.10 (6.9)	
	without Brake	2.30 (7.5)				2.80 (9.2)			
Brake		Internal expanding type, right and left independent with interlocking device							
Differential		Bevel gear							

Note: \*Manufacturer's estimate

\*\*Bar Tire (if equipped)

Model		B1750HSE (2WD)				B1750HSD (4WD)					
Engine gross power		14.9 kW (20 HP)*									
PTO power		11.6 kW (15.5 HP)*									
Engine	Model	D950-5B									
	Type	Vertical, water-cooled, 4-cycle diesel									
	No. of cylinders	3									
	Bore and stroke	75 mm X 70 mm (3.0 in. X 2.8 in.)									
	Total displacement	927 cm <sup>3</sup> (56.6 cu.in.)									
	Rated revolution	43.3 r/s (2600 rpm)									
	Fuel	Diesel fuel No. 2-D [No.1 diesel fuel if temperature is below -10°C (14°F)]									
	Starter	Electric starter with battery, glow plug and decompression device, 12V, 0.8 kW									
	Lubrication	Forced lubrication by trochoidal pump									
	Cooling	Water with pressurized radiator									
Capacities	Battery	12V (45 AH)									
	Fuel tank	18 l (4.8 U.S.gals)									
	Engine crankcase	3.1 l (3.3 U.S.qts.)									
	Engine coolant	3.5 l (3.7 U.S.qts.)									
	Transmission case	13.5 l (14.3 U.S.qts.)									
	Steering gear box	0.2 l (0.2 U.S.qt.)									
	Front axle diff. case	—				1.5 l (1.6 U.S.qts.) Bi-speed Turn: 2.5 l (2.6 U.S.qts.)					
	Front axle gear case	—				0.5 l (0.5 U.S.qt.)					
	Tires	Front	Farm 5.00-10	Farm 5.00-10	Turf 18X9.50-8	Turf 18X9.50-8	Farm 6-12B	Farm 6-12	Turf 20.5X8.00-10	Turf 20.5X8.00-10	
		Rear	8-16	9.5-16	29X12.00-15	31X13.5-15**	8-16	9.5-16	29X12.00-15	31X13.5-15**	
Dimensions	Overall length	mm (in.)	2565 (101.0)	2565 (101.0)	2565 (101.0)	2565 (101.0)	2565 (101.0)	2565 (101.0)	2565 (101.0)		
	Overall width	mm (in.)	990 (39.0)	1045 (41.1)	1140 (44.9)	1240 (48.8)	1050 (41.3)	1095 (43.1)	1140 (44.9)	1240 (48)	
			1110 (43.7)	1145 (45.1)			1110 (43.7)	1145 (45.1)			
	Overall height with ROPS	mm (in.)	1900 (74.8)	1925 (75.8)	1880 (74.1)	1890 (74.4)	1900 (74.8)	1925 (75.8)	1880 (74.1)	1890 (74.4)	
	Wheelbase	mm (in.)	1470 (57.9)	1470 (57.9)	1470 (57.9)	1470 (57.9)	1470 (57.9)	1470 (57.9)	1470 (57.9)	1470 (57.9)	
	Min. ground clearance	mm (in.)	255 (10.0)	285 (11.2)	240 (9.4)	250 (9.8)	240 (9.4)	255 (10.0)	215 (8.5)	215 (8.5)	
	Treads	Front	mm (in.)	710 (28.0)	710 (28.0)	850 (33.5)	850 (33.5)	860 (33.9)	860 (33.9)	895 (35.2)	895 (35.2)
		Rear	mm (in.)	790 (31.1)	795 (31.3) 845 (33.3) 895 (35.2) 1015 (40.0)	840 (33.1)	895 (35.2)	790 (31.1) 910 (35.8)	845 (33.3) 895 (35.2) 1015 (40.0)	840 (33.1)	895 (35.2)
Weight (with ROPS)	kg (lbs.)	575 (1268)	585 (1290)	580 (1279)	585 (1290)	635 (1400)	645 (1422)	640 (1411)	645 (1422)		
PTO shaft	Transmission case rear (rear PTO), Transmission case bottom (mid PTO) and engine front (front PTO)										
	Rear PTO	SAE 1-3/8 2 speeds (9.0 and 14.3 r/s at 41.9 engine r/s) (540 and 858 rpm at 2517 engine rpm)									
	Mid PTO	USA No.5 (KUBOTA 10 tooth) involute spline 1 speeds (40.9 r/s at 41.9 engine r/s) (2455 rpm at 2517 engine rpm)									
Clutch	Dry single plate										
Steering	Recirculating ball type manual steering or integral type power steering (if equipped)										
Transmission	Main-hydrostatic transmission, High-Low gear shift (2 forward, 2 reverse)										
Min. turning radius m (ft)	with Brake	2.10 (6.9)				2.10 (6.9)					
	without Brake	2.30 (7.5)				2.55 (8.4) Bi-speed turn: 2.10 (6.9)					
Brake	Internal expanding type, right and left independent with interlocking device										
Differential	Bevel gear										

Note: \*Manufacturer's estimate  
\*\*Bar Tire (if equipped)

## 2.2 TRAVELING SPEEDS

Model		B1550HST			
Tire sizes		7-16	8-16	29×12.00-15	31×13.5-15
High-Low gear shift lever					
Forward	L	4.64km/h (2.88mph)	4.96km/h (3.08mph)	4.74km/h (2.95mph)	4.87km/h (3.03mph)
	H	11.85km/h (7.36mph)	12.65km/h (7.86mph)	12.12km/h (7.53mph)	12.44km/h (7.73mph)
Reverse	L	3.48km/h (2.16mph)	3.71km/h (2.31mph)	3.56km/h (2.21mph)	3.65km/h (2.27mph)
	H	8.89km/h (5.52mph)	9.49km/h (5.90mph)	9.09km/h (3.37mph)	9.33km/h (5.80mph)

[at 43.3 engine r/s (2600 engine rpm)]

Model		B1750HST			
Tire sizes		8-16	9.5-16	29×12.00-15	31×13.5-15
High-Low gear shift lever					
Forward	L	4.96km/h (3.08mph)	5.30km/h (3.29mph)	4.74km/h (2.95mph)	4.87km/h (3.03mph)
	H	12.65km/h (7.86mph)	13.53km/h (8.41mph)	12.12km/h (7.53mph)	12.44km/h (7.73mph)
Reverse	L	3.71km/h (2.31mph)	3.97km/h (2.47mph)	3.56km/h (2.21mph)	3.65km/h (2.27mph)
	H	9.49km/h (5.90mph)	10.15km/h (6.31mph)	9.09km/h (3.37mph)	9.33km/h (5.80mph)

[at 43.3 engine r/s (2600 engine rpm)]

(Specifications and design subject to change without notice)

# 3. IMPLEMENT LIMITATIONS

The KUBOTA tractor has been thoroughly tested for proper performance with implements sold or approved by KUBOTA. Use with implements which exceed the maximum specifications listed below, or which are otherwise unfit for use with the KUBOTA tractor may result in malfunctions or failures of the tractor, damage to other property and injury to the operator or others. [Any malfunctions or failures of the tractor resulting from use with improper implements are not covered by the warranty.]

Model		B1550HST, B1750HST
Operating condition		General control operation (Flat ground and slope condition)
Lower link end max. loading weight $W_0$		Below 180 kg (400 lbs.)
Actual figures	Implement weight $W_1$	As in the following list
	Trailer loading weight $W_2$	Below 500 kg (1100 lbs.) (without brake) Below 1000 kg (2200 lbs.) (with brake)

Lower link end max. loading weight..... The max. allowable load which can be put on the lower link end:  $W_0$   
 Implement weight..... The implement's weight which can be put on the lower link:  $W_1$   
 Trailer loading weight..... The max. loading weight for trailer (without trailer's weight):  $W_2$

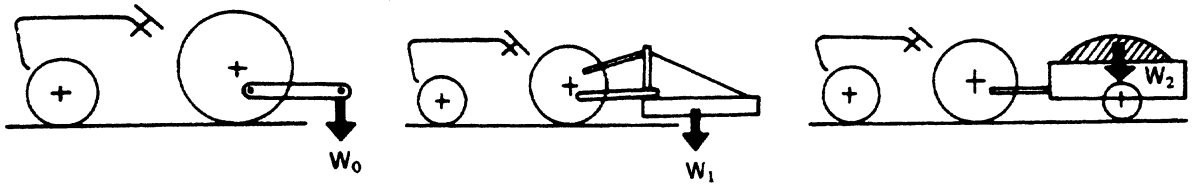

Implement		Remarks	B1550HST	B1750HST
Rotary mower	Rear (1 Blade)	Max. cutting width Max. weight	107 cm (42 in.) 140 kg (300 lbs.)	107 cm (42 in.) 140 kg (300 lbs.)
	Mid or rear (2 to 3 Blade)	Max. cutting width Max. weight	152 cm (60 in.) 140 kg (300 lbs.)	152 cm (60 in.) 140 kg (300 lbs.)
	Sickle bar	Max. cutting width	122 cm (48 in.)	122 cm (48 in.)
Rotary tiller		Max. tilling width Max. weight	107 cm (42 in.) 170 kg (380 lbs.)	107 cm (42 in.) 180 kg (400 lbs.)
Bottom plow		Max. size	30 cm (12 in.) × 1	36 cm (14 in.) × 1
Disc plow		Max. size	56 cm (22 in.) × 1	56 cm (22 in.) × 1
Cultivator		Max. size	122 cm (48 in.) 1 Row	122 cm (48 in.) 1 Row
Disc harrow		Max. harrowing width Max. weight	122 cm (48 in.) 90 kg (200 lbs.)	137 cm (54 in.) 140 kg (300 lbs.)
Sprayer		Max. tank capacity	110 ℓ (30 gals.)	110 ℓ (30 gals.)
Front blade		Max. cutting width Sub frame Oil pressure, relief valve	122 cm (48 in.) Necessary 11.4 MPa (116 kgf/cm <sup>2</sup> , 1650 psi)	122 cm (48 in.) Necessary 11.4 MPa (116 kgf/cm <sup>2</sup> , 1650 psi)
Rear blade		Max. cutting width Max. weight	152 cm (60 in.) 140 kg (360 lbs.)	152 cm (60 in.) 160 kg (350 lbs.)
Front loader		Max. lifting capacity Max. width Sub frame	270 kg (600 lbs.) 107 cm (42 in.) Necessary	270 kg (600 lbs.) 107 cm (42 in.) Necessary
Box blade		Max. cutting width Max. weight	107 cm (42 in.) 170 kg (380 lbs.)	107 cm (42 in.) 170 kg (380 lbs.)
Back hoe (Use maximum rear wheel tread width)		Max. digging depth Max. weight Sub frame	183 cm (72 in.) 270 kg (600 lbs.) Necessary	183 cm (72 in.) 270 kg (600 lbs.) Necessary
Snow blower		Max. working width Max. weight Sub frame	107 cm (42 in.) 160 kg (350 lbs.) Necessary	122 cm (48 in.) 160 kg (350 lbs.) Necessary
Trailer		Max. load capacity	500 kg (1100 lbs.)	500 kg (1100 lbs.)
Three point lift		Max. load capacity	180 kg (400 lbs.)	180 kg (400 lbs.)

# 4. OPERATING NEW TRACTOR

The handling and maintenance of a new tractor determines the length of its service.

A new tractor just off the factory production line has been carefully assembled and tested, however extra care should be taken to operate the tractor for the first 100 hours at a slower speed and avoid excessive load or operation until the various parts become well "broken-in." In order to obtain the maximum performance and the longest life of the tractor, it is very important to break-in your tractor correctly. In handling a new tractor, the following precautions should be observed.

## ■ Do not Operate the Tractor at Full Speed or Load for the First 100 Hours.

- Do not start quickly or apply the brakes suddenly.
- In winter, operate the tractor only after fully warming up the engine.
- Do not run the engine at speeds faster than necessary.
- On rough roads, slow down to suitable speeds. Do not operate the tractor at excessive speed.

The above precautions are applicable to all tractors, whether old or new.

## ■ Changing Lubricating Oil for New Tractors

Lubricating oil is especially important for a new tractor. The various parts are not "broken-in" and small metal particles may develop during operation, causing the parts to wear out or become damaged.

Care should be taken to change the lubricating oil earlier than would ordinarily be required in an older machine.

For further details of change interval hours, see check list. (See page 31)

## ■ Read "Safe Operation"

Please read "Safe Operation" before attempting to start or operate the tractor.

## 4.1 LOADING AND UNLOADING

- (1) When loading (or unloading) a tractor onto a truck or trailer, chock the truck or trailer's tires.
- (2) Securely fix a rugged ramp with non-skids to the truck or trailer bed and make sure that there are no people around before starting to load or unload the tractor.
- (3) Always back the tractor when going up the ramp



# 5. INSTRUMENT PANEL AND CONTROLS

## 5.1 SWITCHES

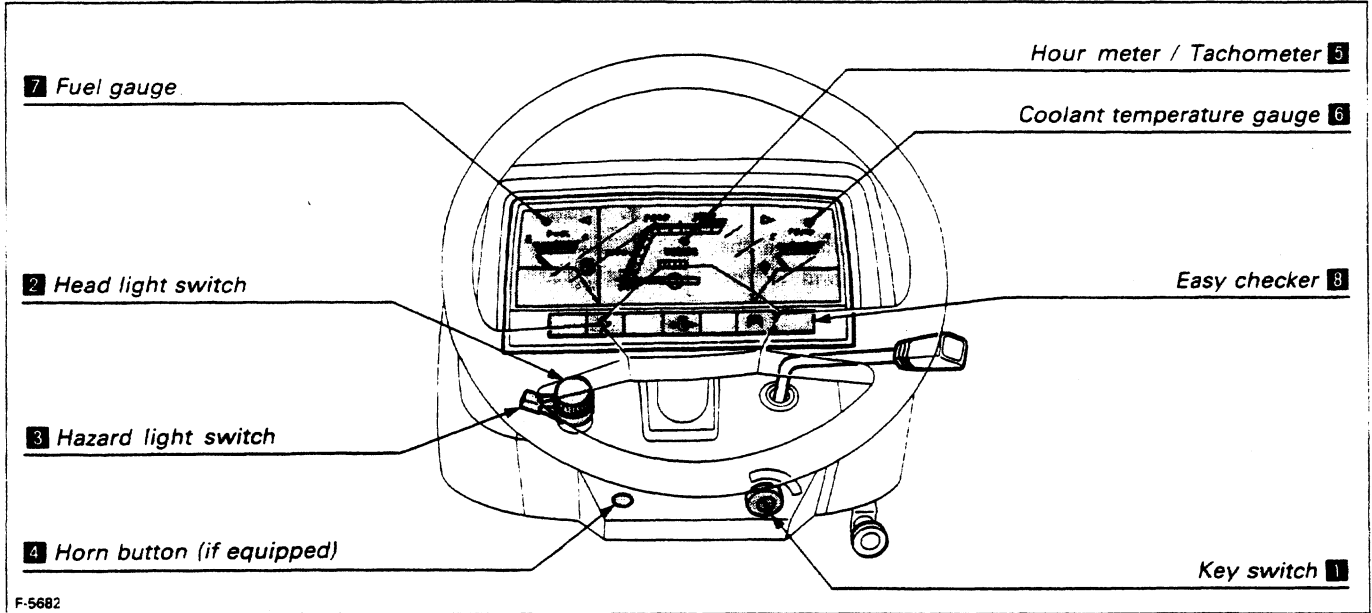

F-5682

### 1 Key Switch

- ⚡ OFF..... The position where the key can be inserted into or removed from the key switch. [The engine stops the moment the key is turned to this position.]
- ⚡ ON..... The engine keeps running.
- 🔥 Preheat..... The combustion chamber is heated.
- 🕒 Start..... Depress the clutch pedal fully and turn the key switch to this position to start the engine.

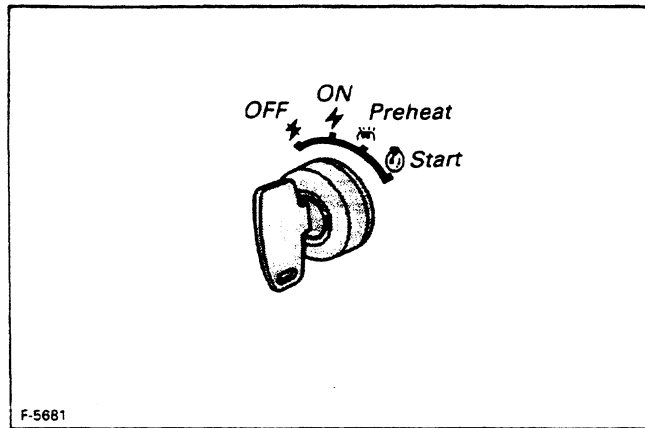

F-5681

### IMPORTANT

- Because of the safety device, the engine may not be started except when the clutch is disengaged.

### 2 Head Light Switch

- OFF..... Head lights OFF.
- ☞..... Head lights dimmed, low beam.
- ☜..... Head lights ON, high beam.

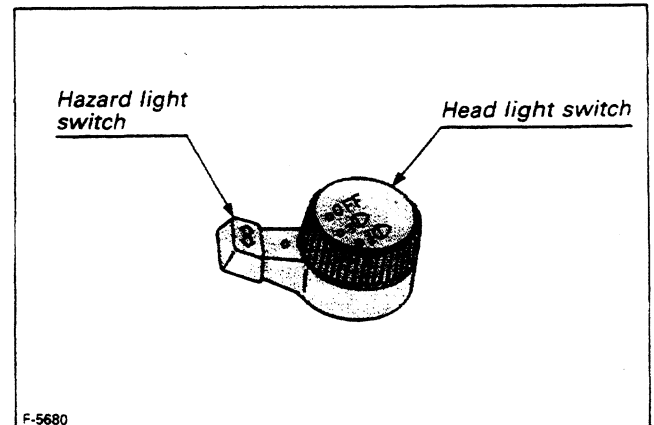

F-5680

### 3 Hazard Light Switch

When hazard light switch is turned to either direction, the hazard lights blink.  
(Hazard light is standard for USA)

**4 Horn Button (if equipped)**

The horn will sound when the key is in the "ON" position.

**5 Hour Meter/Tachometer**

This meter gives readings for engine speed, PTO shaft speed and the hours the tractor has been operated.

- (1) The indicator shows the engine speed and corresponding PTO shaft speed.
- (2) The hour meter indicates in five digits the hours the tractor has been used; the last digit indicates 1/10 of an hour.

**6 Coolant Temperature Gauge**



- (1) With the key switch at "ON", this gauge indicates the temperature of the coolant. "C" for "cold" and "H" for "hot".
- (2) If the indicator reaches the "H" setting (red zone), coolant is overheated. Check the tractor by referring to "Coolant" on page 38.

**7 Fuel Gauge**

The fuel gauge indicates the amount of fuel.

**8 Easy Checker**



-  Alarm for when the electrical charge system is not functioning properly.
-  Alarm for when the engine oil pressure is low.
-  Glow Plug Indicator (Pre-heating Indicator)  
When the key switch is in the "Preheat" position, the glow plug indicator illuminates

**◆ How to check the Easy Checker**

- (1) When the key switch is turned "ON", all the lights except the glow plug indicator illuminates. When engine starts up, all the lights should go off.
- (2) If trouble should occur at any location while the engine is running, the warning light corresponding to that problem comes on.

**IMPORTANT**

- Daily checks with the Easy Checker only, are not sufficient. Always conduct daily checks carefully by referring to "Daily Checks." See page 30.

**■ Fuses**

Fuse.....	15 ampere
Fusible link.....	200 ampere

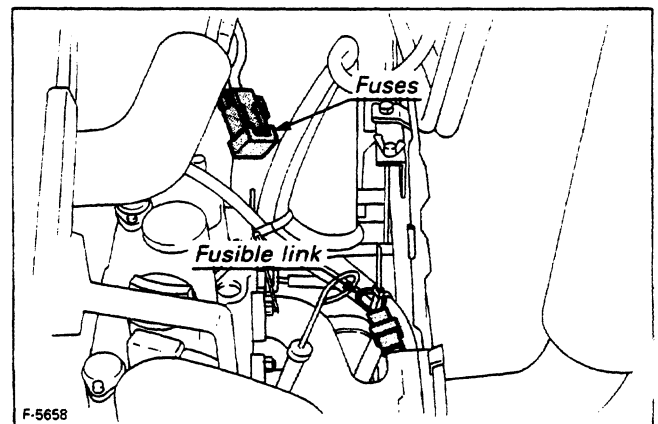

## 5.2 CONTROLS

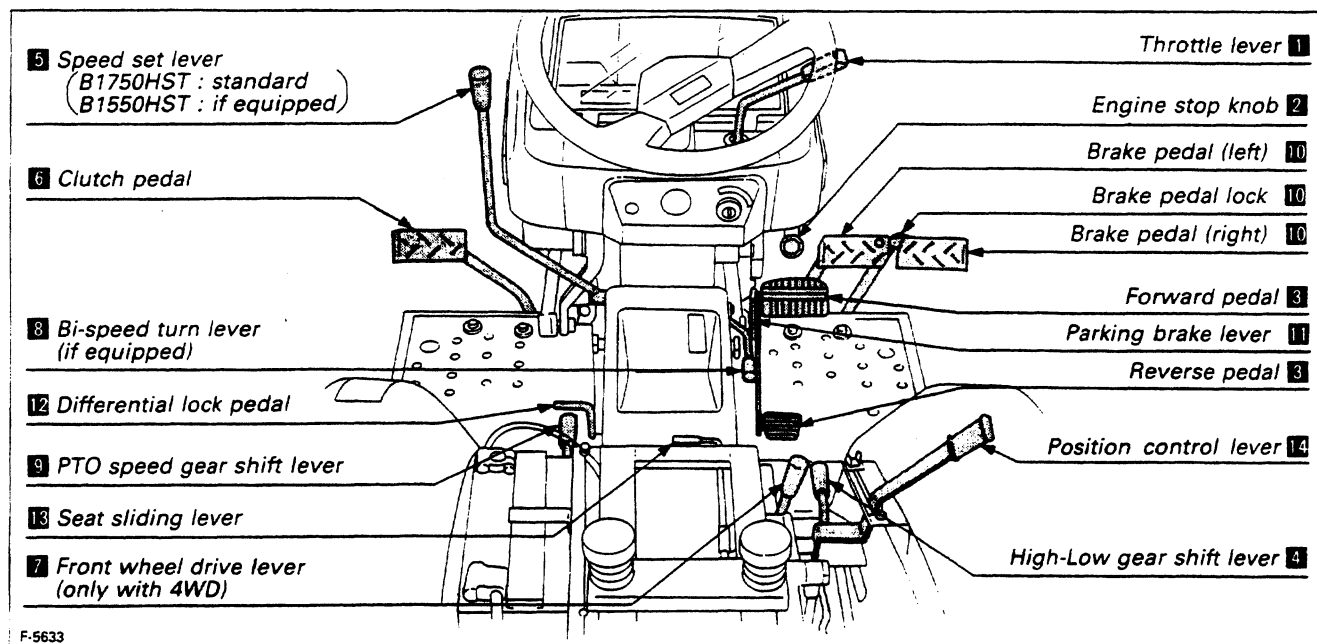

### 1 Throttle Lever

Pulling the throttle lever clockwise increases engine speed, and pushing it counterclockwise decreases engine speed.

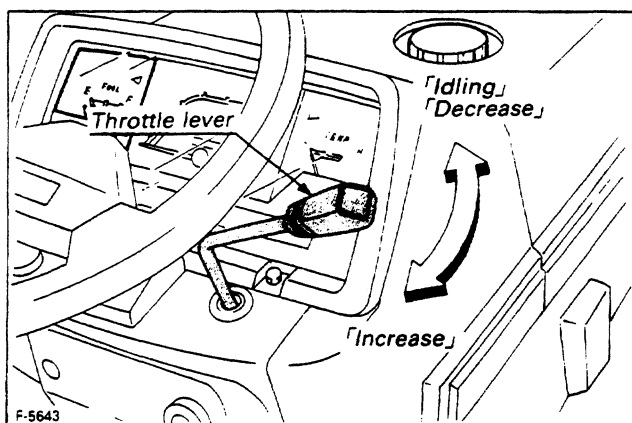

### 2 Engine Stop Knob

The engine stops when the key switch is turned off. If the engine does not stop, pull engine stop knob back and hold it until the engine stops. After the engine has stopped, be sure to push the stop knob back in, or the engine will not start the next time.

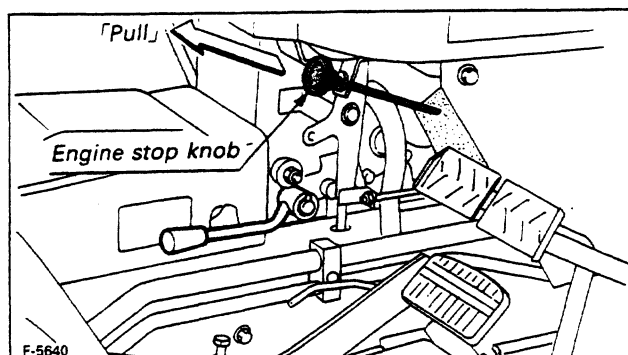

### 3 Speed Control Pedal

#### Forward Pedal

Depress the forward pedal with the toe of your right foot to move forward.

#### Reverse Pedal

Depress the reverse pedal with the heel of your right foot to move backward. Speed Set Device must be disengaged before depressing reverse pedal.

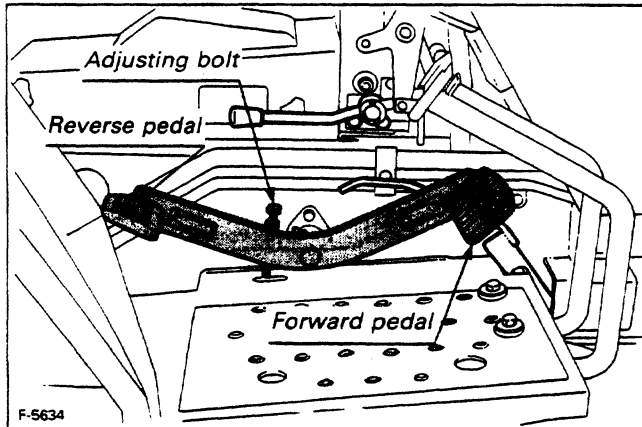

### 4 High-Low Gear Shift Lever

High-low gear shift lever moves in the form of "1" in 3 stages, "Low", "Neutral" and "High".

By using the speed control pedal and high-low gear shift lever, various speeds can be obtained.

#### IMPORTANT

- To shift high-low gear shift lever, disengage the speed set lever and stop the tractor before attempting to proceed with speed change.

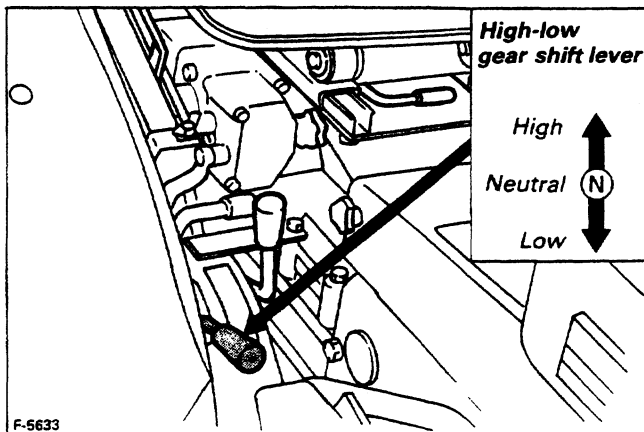

### 5 Speed Set Device

(B1750HST: Standard)  
(B1550HST: if equipped)



#### CAUTION

- Pull the speed set lever completely to the rear before starting the engine.

The Speed Set Device is designed for tractor operating efficiency and operator comfort. This device will provide a constant forward operating speed by mechanically holding the speed control pedal at the selected position.

**Speed set device can not be set at high speed range.**

- To engage Speed Set Device
  1. Accelerate speed to desired level using Speed Control Pedal, and move lever forward.
  2. Release Speed Control Pedal and desired speed will be maintained.
- To disengage Speed Set Device, move lever rearward.

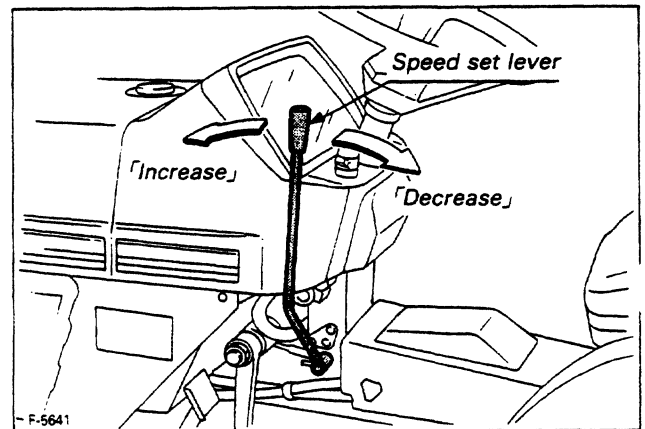

### 6 Clutch Pedal

The clutch is disengaged when the clutch pedal is fully pressed down.

#### IMPORTANT

- (1) The clutch pedal must be quickly disengaged and engaged slowly.
- (2) Never operate the tractor with your foot resting on the clutch pedal. Doing so may contribute to premature clutch wear.

## 7 Front Wheel Drive Lever (4WD)

The front wheel drive is used only when greater traction power is required or to prevent the tractor from lunging while rotary tilling hard soil.

Lowering the lever engages the front wheels for 4 wheel drive.

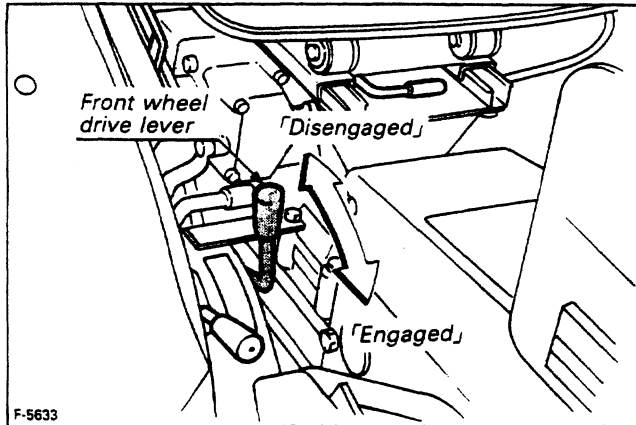

## 8 Bi-Speed Turn Lever (if equipped)



### CAUTION

- (1) Do not use "Bi-speed Turn" at high speed.
- (2) "Bi-speed Turn" enables short fast turns, therefore, become familiar with its performance before operating in close or confined areas.

- (1) Bi-Speed Turn system operates only when engaged and front wheel exceeds 35 degree turning angle.
- (2) Bi-Speed shift lever can be activated only when front wheels are in straight ahead position.
- (3) Bi-Speed turn accelerates front tire rotation 1.7 times faster than conventional DT tractor front tires.

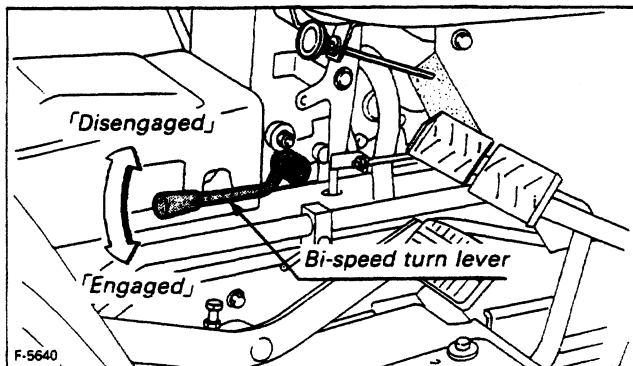

## 9 PTO Speed Gear Shift Lever



### CAUTION

- To prevent overspeeding a PTO driven implement and possibly causing personal injury, use the 2nd PTO speed only when higher rpms are specifically recommended by the implement manufacturer.

The tractor has two rear PTO speeds and one mid PTO speed.

1st — Rear — 540 rpm, 2nd — Rear — 858 rpm  
Mid — 2455 rpm

To use 2nd PTO speed, rotate the restricting plate. Replace restricting plate to original position following use of 2nd PTO speed position.

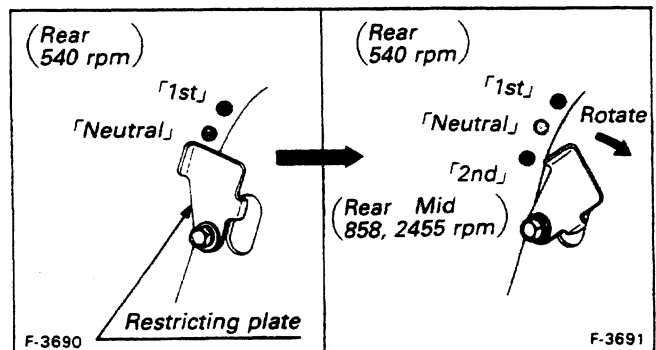
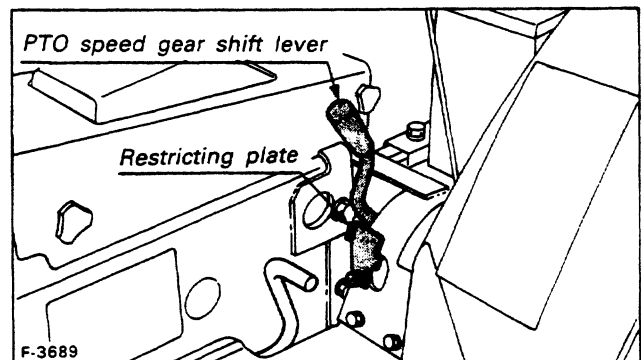

## Mid PTO

The mid PTO is available for KUBOTA mid mount mower.

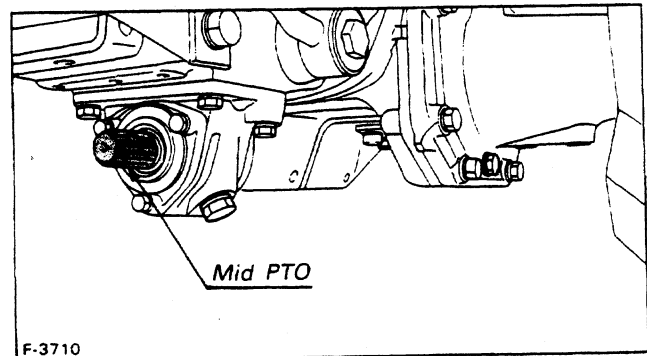

## 10 Brake Pedals (Right and Left)



### WARNING

- Applying only one rear wheel brake at high speeds could cause the tractor to swerve or roll-over.

- (1) Before operating the tractor on a road, be sure to interlock the right and left pedals as illustrated below.
- (2) Use individual brakes to assist in making sharp turns at slow speed (Field Operation Only). Disengage the brake pedal lock and depress only one brake pedal.

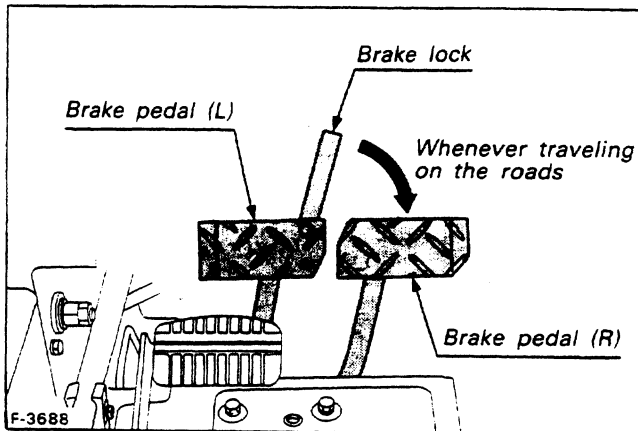

## 11 Parking Brake Lever

- (1) To set the parking brake;
  - Interlock the brake pedals.
  - Depress the brake pedals.
  - Latch the brake pedals with the parking brake lever.
- (2) To release the parking brake, depress the brake pedals again.

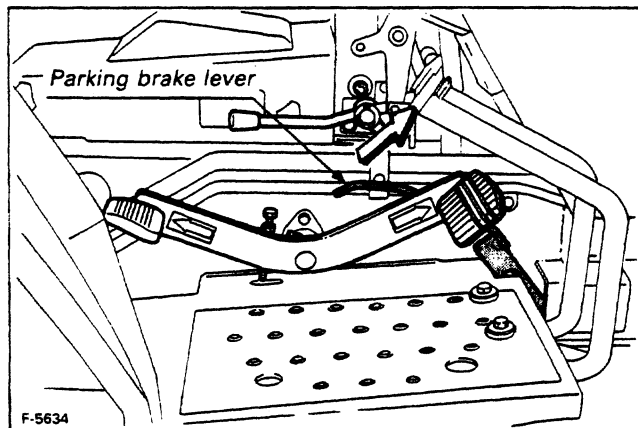

## 12 Differential Lock Pedal



### CAUTION

- Never apply the differential lock when traveling at high speeds. Doing so could cause loss of steering control.

Differential lock is applied only in cases when the wheels are likely to slip, or one of the rear wheels slips.

Lightly stepping on the differential lock pedal with the heel makes the rear wheels run at equal speed. To unlock, release the pedal.

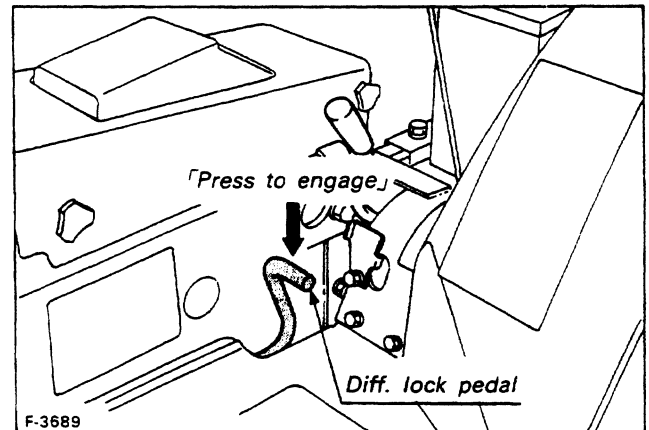

## 13 Adjustable Sliding Seat

The operator's seat position can be adjusted forward a backward in 100 mm (4 in.) range by pulling the seat sliding lever.

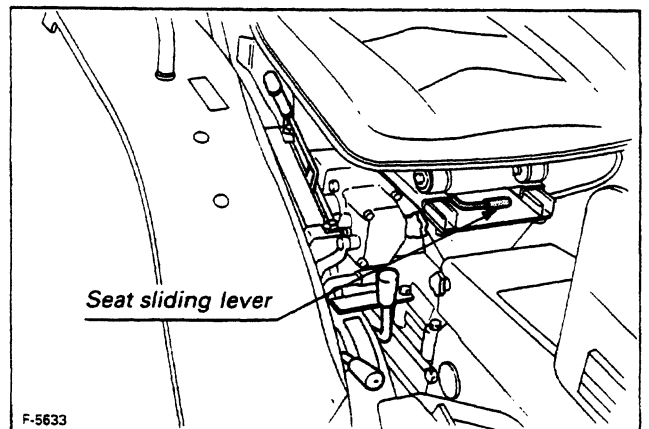

## ■ How to Open the Hood and How to Remove the Engine Cover



### CAUTION

To avoid personal injury from contact with moving parts;

- (1) Never open the hood and remove the engine cover while the engine is running.
- (2) Do not touch muffler or exhaust pipes while they are hot; severe burns could result.

To open the hood, remove the hood latch by lifting the lever located in hood between head lights.

Lift the hood from the front.

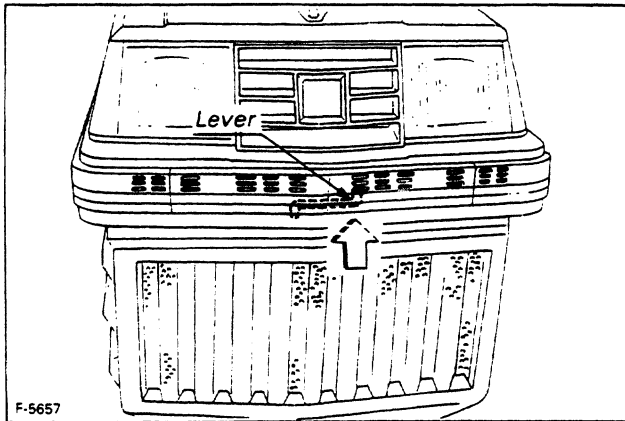

### IMPORTANT

- To secure lock position of the hood, push the link to the arrow head as shown in the illustration.

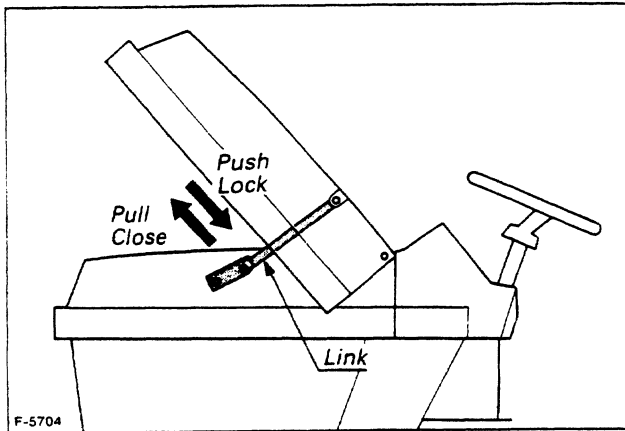

To remove the engine cover, loosen the bolt and the wing bolt, and remove the knob bolt.

Pull the top of engine cover like the arrow, and move it forward.

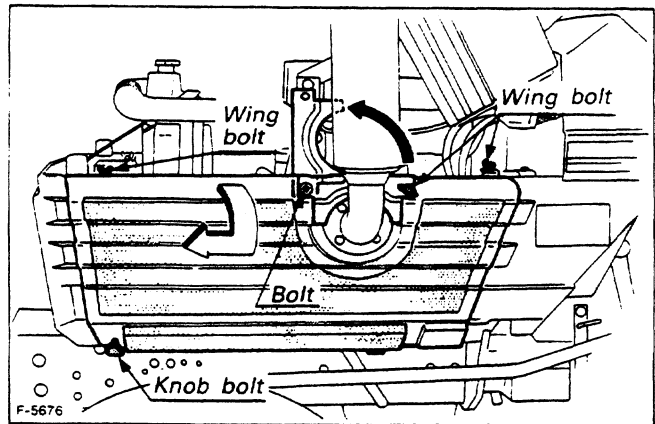

## 14 Position Control Lever

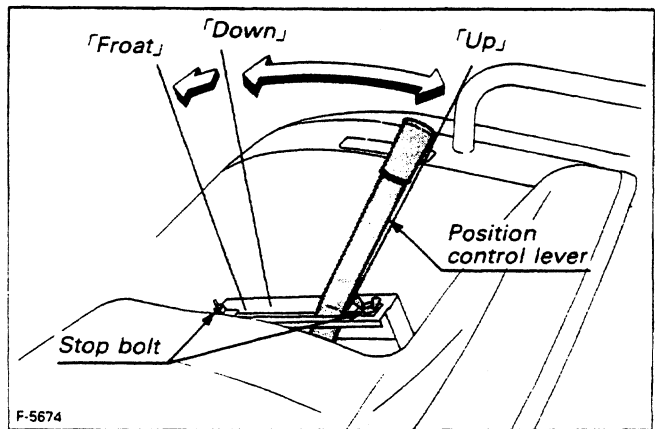

### (Operation with position control)

- (1) To raise implement, pull the lever back fully.  
If the relief valve is activated, push the position control lever forward slightly to prevent the system from operating at relief pressure.
- (2) To lower implement, push the lever forward.

### IMPORTANT

- (1) Do not operate until the engine is well warmed up. If operation is attempted while the engine is still cold, the hydraulic mechanism will not properly function and its service life will be shortened.
- (2) If noises are heard when implement is lifting after the hydraulic control lever has been activated, the hydraulic mechanism is not adjusted properly. Unless corrected the unit will be damaged. Contact your Kubota dealer for adjustment.

### ■ Implement Lowering Speed Control

Adjust lowering speed of implement by turning the lever under the seat. The lowering speed depends on weight of implement.



#### CAUTION

- When transporting on the road, set the implement lowering speed control in the "lock" position to hold the implement in the raised position.

#### IMPORTANT

- It should take two or three seconds for the implement to descend from the fully raised position to the fully lowered position.

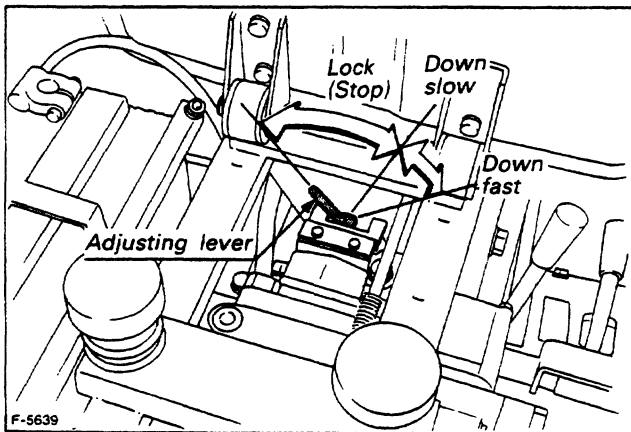

### ■ Power Steering (if equipped)

- (1) The power steering system is actuated only while the engine is running. As long as the engine is off, the tractor with power steering functions the same as without power steering.
- (2) Do not turn the steering wheel while the tractor is stopped or steer the tractor forcibly with a front wheel in a ditch. This action may damage the front wheels, front axle, and power steering.
- (3) Avoid operating the tractor continuously with the steering wheel turned all the way to either side. Keeping the relief valve activated may cause excessively high oil temperature and failure of the pump and steering linkage.



#### CAUTION

- Power steering makes the steering wheel easy to turn. Drive the tractor with care especially when traveling on a road, or at high speeds.



## 5.3 AUXILIARY HYDRAULICS



### CAUTION

- Escaping hydraulic fluid under pressure can have sufficient force to penetrate skin, causing serious personal injury. Before disconnecting hydraulic lines, be sure to relieve all pressure. Before applying pressure to system, be sure all connections are tight and that lines, pipes, and hoses are not damaged. Fluid escaping from a very small hole can be invisible. Use a piece of cardboard or wood, rather than hands, to search for suspected leaks. If injured by escaping fluid, see a doctor at once. Serious infection or reaction can develop if proper medical treatment is not administered immediately.

### Hydraulic Block Type Outlet

Hydraulic block type outlet is useful when adding hydraulic operated equipment such as: power steering, front end loader, front blade, etc.

#### WHEN ATTACHING IMPLEMENT

- Remove the plugs ① and lock plate ②.
- Route the implement inlet ④ and outlet ③ hoses as shown in the illustration.
- Move the directional valve ⑤ forward to pin ⑥ when implement is attached.

#### IMPLEMENT

- When an implement is not attached be sure the directional valve ⑤ is turned back against pin ⑦ and the lock plate ② is installed.

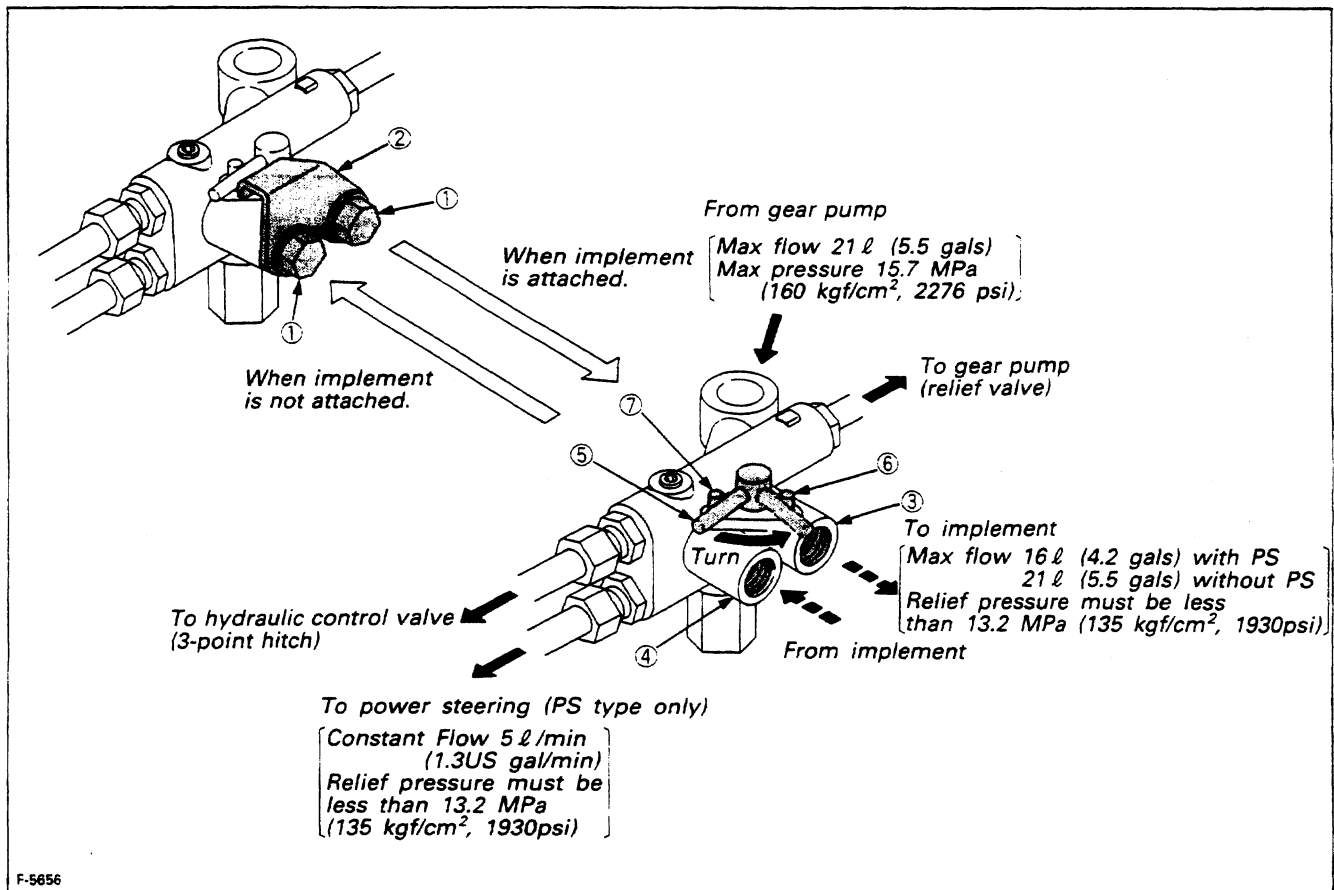

# 6. THREE-POINT HITCH & DRAWBAR

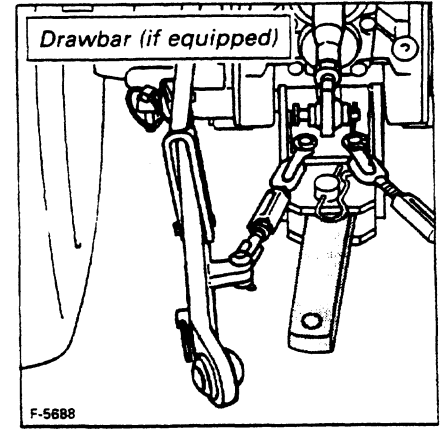
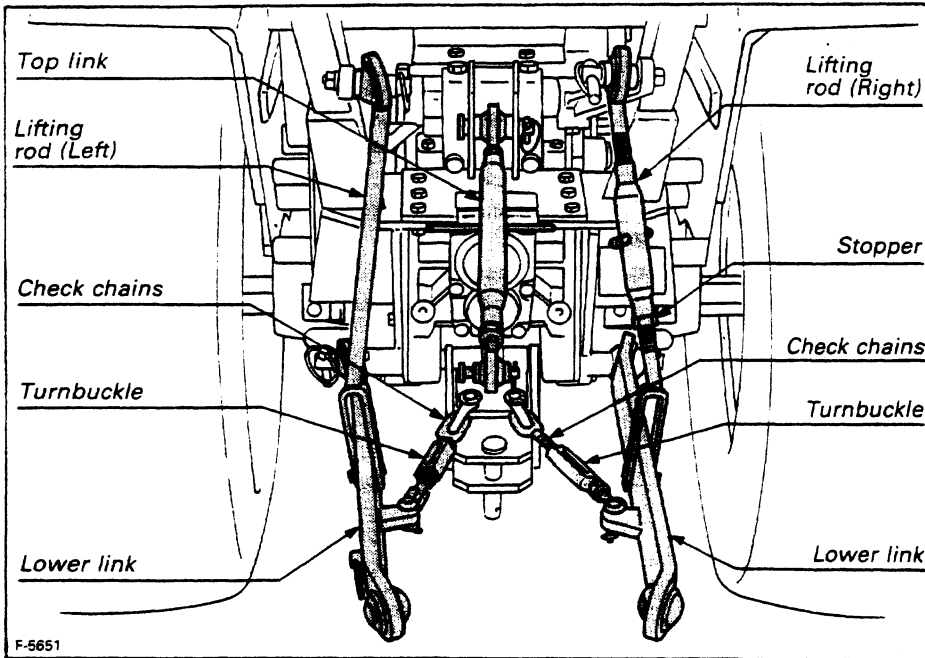

### ■ Adjustment of Top Link

- (1) Adjust the angle of the implement to the desired position by shortening or lengthening the Top Link.
- (2) The proper length of the top-link varies according to the type of implement being used.

### ■ Adjustment of Lifting Rod

- (1) Level a 3-point mounted implement from side to side by turning the lifting rod lever to shorten or lengthen the adjustable lifting rod.
- (2) After the adjustment is completed, secure with the stopper.
- (3) Correct positioning of the lifting rod to the lower link is shown below. Positioning varies according to the type of implement being used.

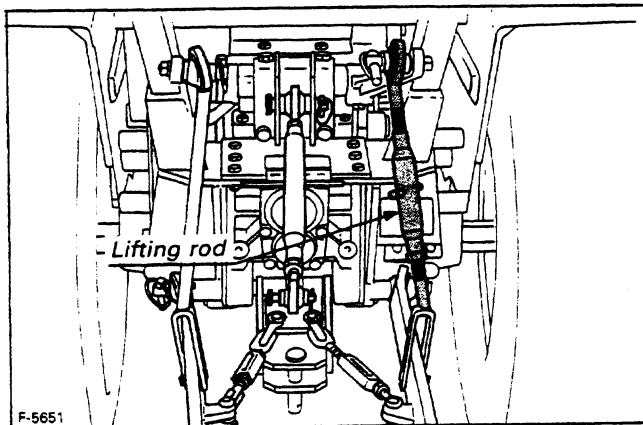

### ■ Adjustment of Check Chains

Adjust the turnbuckle to control horizontal sway of the implement.

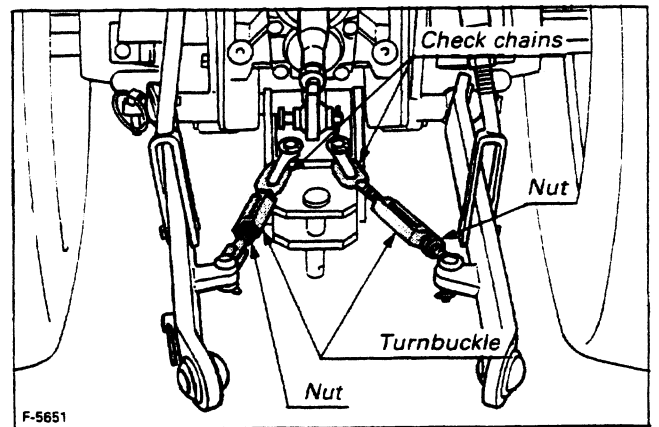

Type of implement	Chain adjustment
Plow, Furrower, Subsoiler, Cultivator, Ditcher	Loosen until the implement can be moved 50 to 60 mm (2 to 2.5 in.) horizontally.
Rotary, Mower, Hayrake, Tedder, Ridger	Tighten

# 7. WHEELS, TIRES AND BALLAST



## CAUTION

- (1) Never operate tractor with a loose rim, wheel, or axle.
- (2) Check all bolts frequently and re-tighten to specified torque.
- (3) Check wheel hub pin and snap pin for secure set.

## IMPORTANT

- Re-check after first few hours of operation.



## CAUTION

- (1) When working on slopes or when working with a trailer, set the wheel tread as wide as practical for the job for maximum stability.
- (2) After the change of rear wheel tread, set wheel tube pin and snap pin securely and tighten the nut of the cotter pin to specified torque.

## NOTE

- Wheels with beveled or tapered holes: Use the tapered side of lug nut.

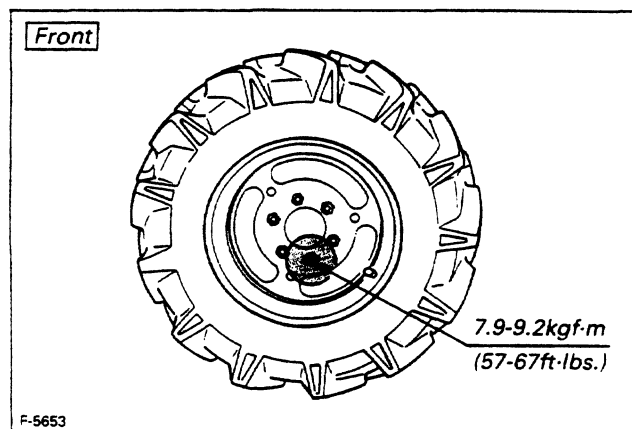
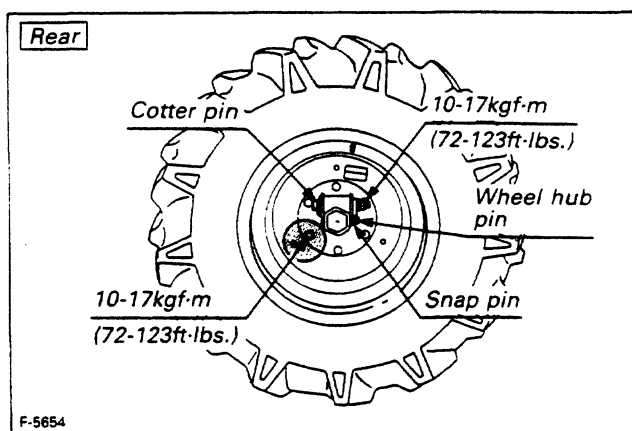
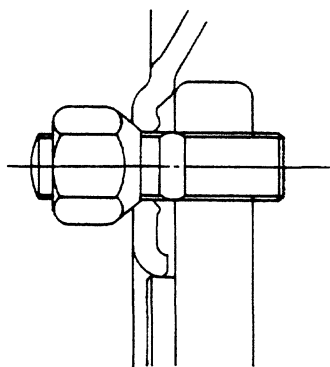

# 7.1 TREADS

## B1550HST

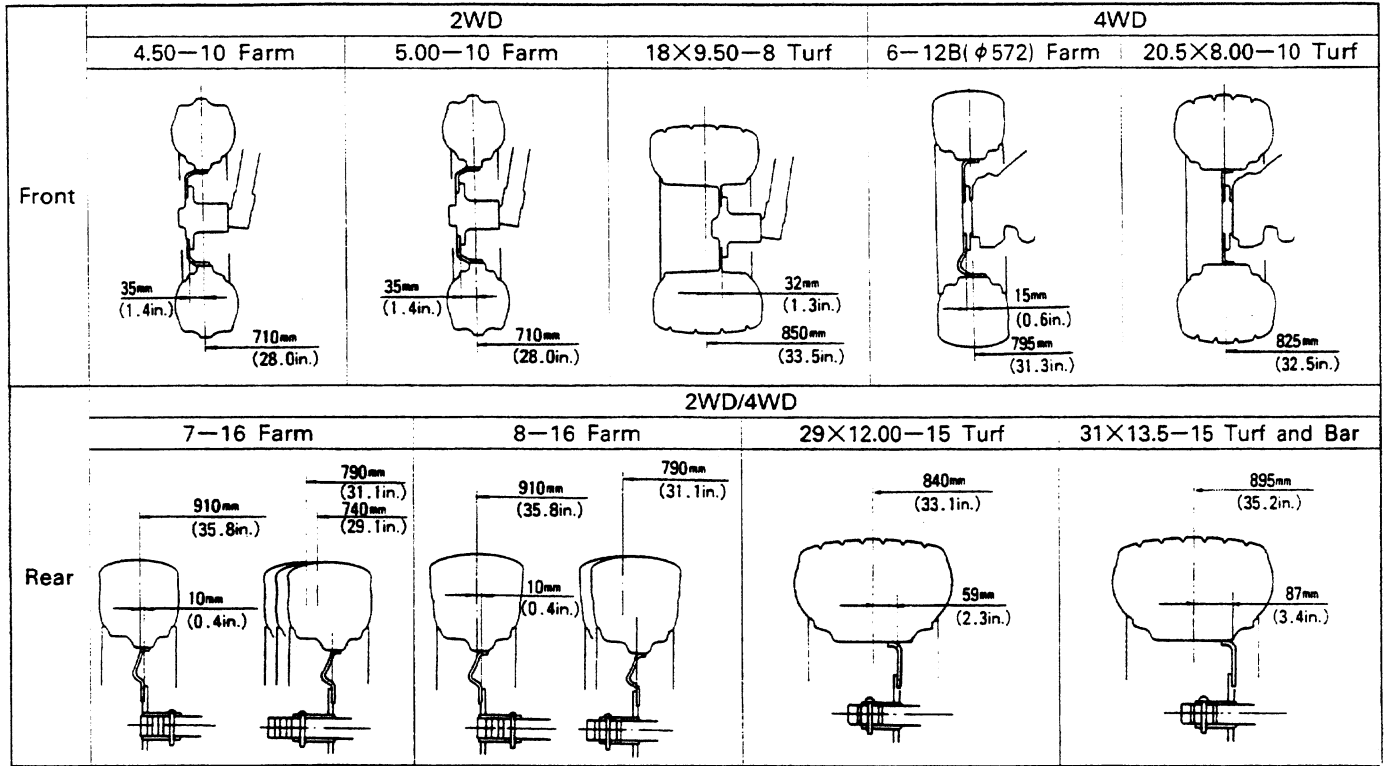

F-305f

## B1750HST

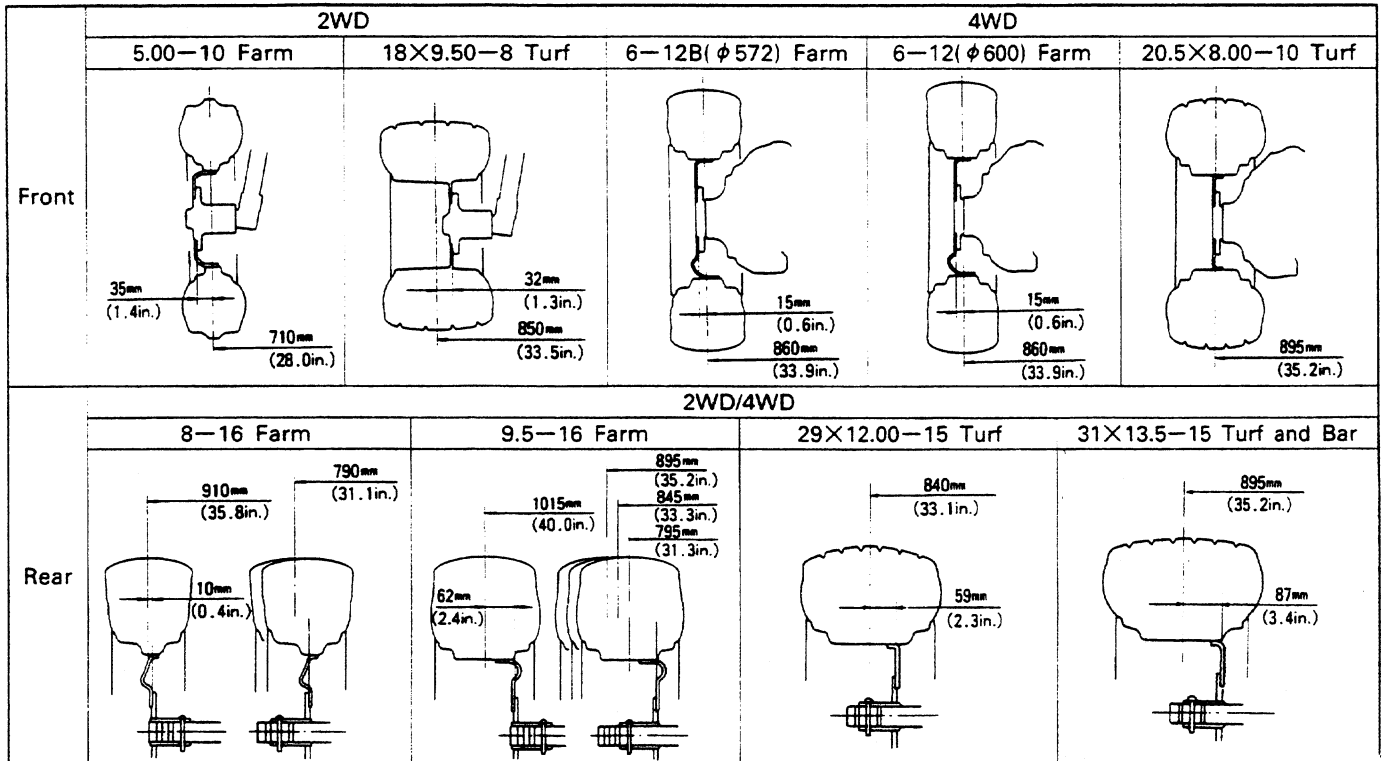

**IMPORTANT**

- (1) Always attach tires as shown in the above drawings.
- (2) If not attached as illustrated, transmission parts may be damaged.

Do not use tires larger than specified.

F-30E

## 7.2 WHEEL HUB

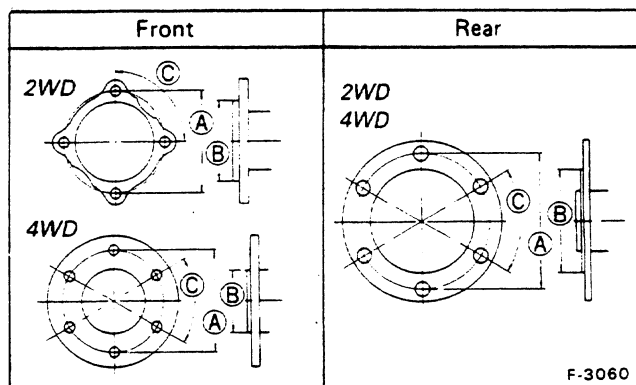

	Front wheel hub		Rear wheel hub
	2WD	4WD	2WD/4WD
Bolt circle diameter <b>A</b>	115mm (4.53 in.)	115 mm (4.53 in.)	152 mm (6.0 in.)
Number of bolts	4	6	6
Bolt specifications (mm)	M12×Pitch 1.25	M12×Pitch 1.25	M14×Pitch 1.5
Pilot bore diameter <b>B</b>	90 mm (3.54 in.)	69.5 mm (2.74 in.)	114 mm (4.49 in.)
Hole spacing <b>C</b>	Equal 90 deg.	Equal 60 deg	Equal 90 deg.

## 7.3 TIRES

The tire pressure is factory-set to the correct level, but it will drop slowly with time. Check daily and inflate as necessary.

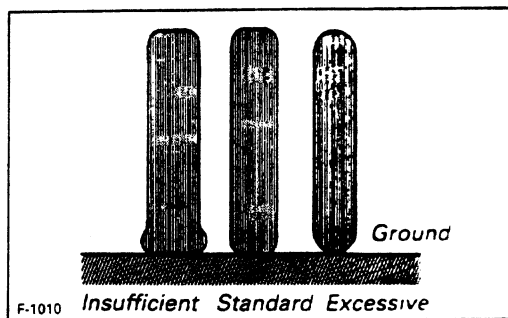

### CAUTION

- Do not attempt to mount a tire. This should be done by a qualified person with the proper equipment.

Qualified persons with the proper tire mounting equipment should recognize the following warning.



### WARNING

- Never exceed the pressure shown below (maximum limit) when attempting to seat a bead. If beads have not been seated by the time the pressure reaches maximum limit, deflate the assembly, reposition the tire on the rim, relubricate and reinflate. After seating the bead, adjust inflation pressure as recommended in the inflation pressure chart.

### Maximum Limit of Inflation Pressure (In seating a bead)

Farm tire	4.50—10, 4PR	345kPa (3.5kgf/cm <sup>2</sup> , 50psi)
	5.00—10, 4PR	
	6—12, 4PR	
	7—16, 4PR	
	8—16, 4PR	
Turf tire	9.5—16, 4PR	296kPa (3.0kgf/cm <sup>2</sup> , 43psi)
	18×9.50—8, 4PR	
	20.5×8.00—10, 4PR	
	29×12.00—15, 4PR	
	31×13.5—15, 4PR	

## 7.4 BALLAST

### ■ Selecting Front Ballast

Add weight to front end if needed for stability.

Heavy pulling and heavy rear mounted implements tend to lift front wheels. Add enough ballast to maintain steering control and prevent tip over.

Remove weight when it is no longer needed. Front weights are available from your Kubota Dealer.

Your dealer can help you decide how much is required for your particular application.



### CAUTION

- Additional ballast will be needed for transporting heavy mounted implements. When the implement is raised, drive slowly over rough ground, regardless of how much ballast is used.

### ■ Select Rear Ballast Carefully.

Add weight to rear wheels if needed to improve traction or for stability. The amount of rear ballast should be matched to job and the ballast should be removed when it is not needed. Rear wheel weights are available or liquid may be added to the rear tires. Consult your Kubota dealer for the correct ballasting necessary for your particular application.

### ■ Using Liquid Weight in Rear Tires

Water and calcium chloride solution provides, safe economical ballast. Used properly, it will not damage tires, tubes or rims. The addition of calcium chloride is also recommended to prevent the water from freezing.

Use of this method of weighting the wheels has the full approval of the tire companies. See your tire dealer for this service. Do not fill any tire more than 75% full (to valve stem level).

**Liquid weight per tire (75 Percent filled)**

Tire sizes	7-16	8-16	9.5-16
Slush free at -10°C (13°F) Solid at -30°C (-23°F) [Approx. 1 kg (2 lbs.) CaCl <sub>2</sub> per 4 l (1 gal) of water]	26 kg (57 lbs.)	35 kg (77 lbs.)	54 kg (119 lbs.)
Slush free at -24°C (-12°F) Solid at -47°C (-52°F) [Approx. 1.5 kg (3.5 lbs.) CaCl <sub>2</sub> per 4 l (1 gal) of water]	28 kg (62 lbs.)	37 kg (82 lbs.)	57 kg (126 lbs.)
Slush free at -47°C (-52°F) Solid at -52°C (-62°F) [Approx. 2.25 kg (5 lbs.) CaCl <sub>2</sub> per 4 l (1 gal) of water]	29 kg (64 lbs.)	39 kg (86 lbs.)	60 kg (132 lbs.)

**IMPORTANT**

- Do not fill the following tires with water, or the tires will be damaged.  
4.50-10, 6-12, 18X9.50-8, 29X12.00-15  
5.00-10, 20.5X8.00-10, 31X13.5-15

**■ Inflation Pressure**

Front	4.50-10, 4PR	140kPa (1.4kgf/cm <sup>2</sup> ;20psi)
	5.00-10, 4PR	270kPa (2.8kgf/cm <sup>2</sup> ;40psi)
	6-12, 4PR	200kPa (2.0kgf/cm <sup>2</sup> ;28psi)
	18X9.50-8, 4PR	140kPa (1.4kgf/cm <sup>2</sup> ;20psi)
	20.5X8.00-10, 4PR	160kPa (1.6kgf/cm <sup>2</sup> ;23psi)
Rear	7-16, 4PR	180kPa (1.8kgf/cm <sup>2</sup> ;26psi)
	8-16, 4PR	160kPa (1.6kgf/cm <sup>2</sup> ;23psi)
	9.5-16, 4PR	140kPa (1.4kgf/cm <sup>2</sup> ;20psi)
	29X12.00-15, 4PR	140kPa (1.4kgf/cm <sup>2</sup> ;20psi)
	31X13.5-15, 4PR	140kPa (1.4kgf/cm <sup>2</sup> ;20psi)

**7.5 TOE-IN**

Toe-in equals distances (C)/(D)-(A)/(B): 0 to 5mm (0 to 0.2 in.). To adjust toe-in loosen the lock nut and adjust the length of the tie rod until the proper toe-in measurement is obtained. Retighten the lock nut.

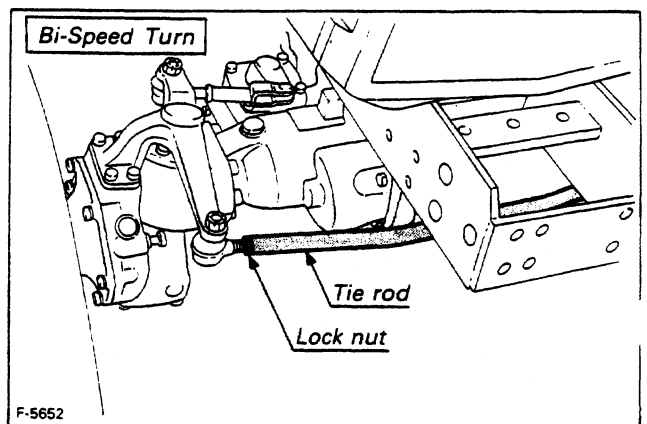
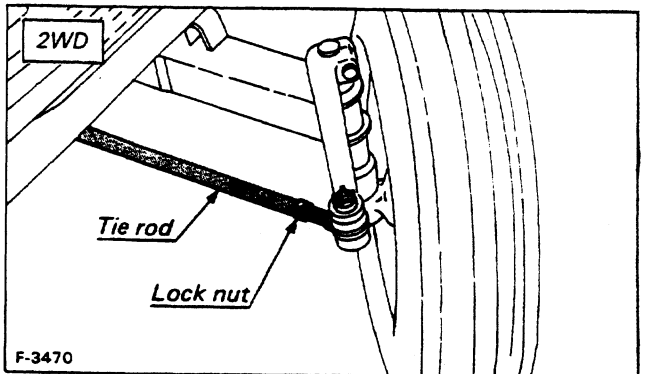
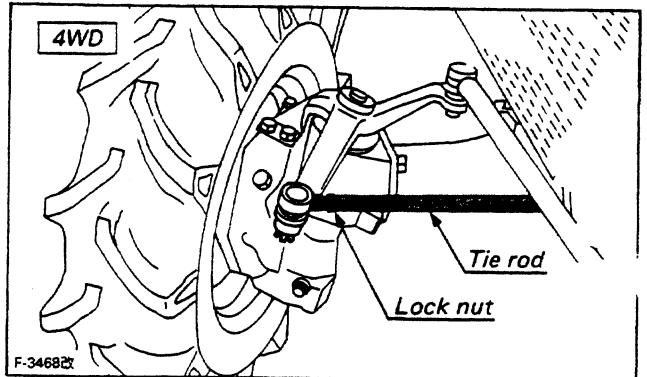
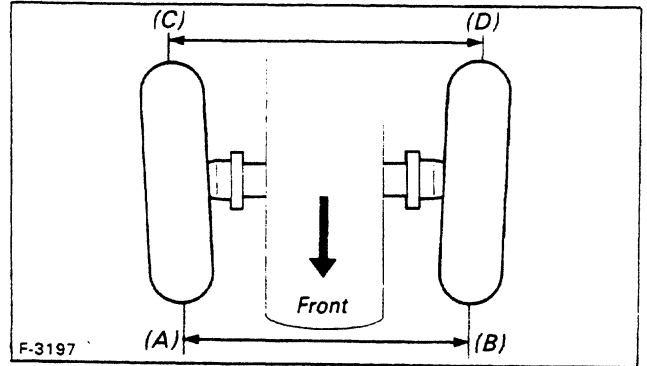

# 8. OPERATING INSTRUCTIONS

## Pre-Start Checks

Prior to starting the engine, make pre-start checks according to the Maintenance Check List on page 30 to 31.



### CAUTION

- (1) Read "Safe Operation" in the front of this manual.
- (2) Read the Warning and Caution labels located on the tractor.

## 8.1 OPERATING THE ENGINE



### CAUTION

- (1) To avoid the danger of exhaust fume poisoning, do not operate the engine in a closed building without proper ventilation.
- (2) To avoid personal injury, always set main gear shift lever and PTO speed gear shift lever to the "neutral" positions before starting the engine.

### ■ Starting

- (1) Sit in the operator's seat. If the tractor is equipped with a ROPS, fasten the seat belt.
- (2) Set the parking brake.
- (3) Place Main gear shift lever and PTO speed gear shift lever in the "neutral" positions.
- (4) Place hydraulic control lever in lowest position.
- (5) Push in the engine stop knob.
- (6) Insert the key into the key switch and turn it by one notch.
- (7) Make sure that the easy checker light is on.
- (8) Depress the clutch pedal fully, turn the key switch right, and hold it for about 5 seconds. (at the preheat position)

For the appropriate preheating time, refer to the table below:

Temperature	Preheating Time
Over 0°C (32°F)	5 sec.
0 to -5°C (32 to 23°F)	10 sec.

- (9) Turn the key switch to the start position and the starter will turn and the engine should start.
- (10) Make sure that the easy checker light has gone off. If the light is still on, immediately stop the engine and check the lubrication system.
- (11) Warm the engine by running at the medium speed.

### IMPORTANT

- (1) Do not turn the key switch to start position while the engine is running.
- (2) When the temperature is below 0°C(32°F), place the main gear shift lever in the neutral position and keep the engine at medium speed to warm up the lubricant of engine and transmission at least 10 minutes. If the tractor is operated before the lubricant of engine and transmission is warmed sufficiently, the tractor life will be shortened.
- (3) Do not operate the tractor under full load condition until it is sufficiently warmed up.
- (4) Do not use starting fluid, or engine will be damaged.

### ■ Stopping

Turn the key switch off and remove the key.

## 8.2 OPERATING THE TRACTOR

### ■ Starting

- (1) Depress the clutch pedal to disengage the clutch.
- (2) Shift levers to the desired speed position.
- (3) Unlock the parking brake.
- (4) Speed up the engine by moving the throttle lever clockwise.
- (5) Slowly release the clutch pedal.
- (6) Depress the forward pedal with the toe of your right foot to move forward.
- (7) Depress the reverse pedal with the heel of your right foot to move backward.



### CAUTION

- (1) Interlock the right and left brake pedals before starting. Uneven braking results in a sharp turn, which may turn over the tractor.
- (2) Do not allow any person other than the driver to ride on the tractor at any time.
- (3) Do not drive the tractor close to the edges of ditches or banks which may break under the weight of the tractor, especially when the ground is loose or wet.
- (4) Slow the tractor down to a safe speed before turning.
- (5) Do not drive the tractor on the road with the implement in motion.
- (6) After the differential lock has been used, be sure to see that it has been released.
- (7) When traveling on a road, attach the S.M.V. emblem to the tractor to identify it as a slow moving vehicle.

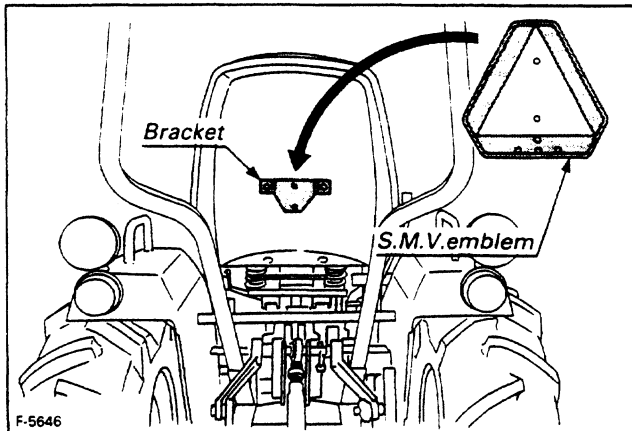

### IMPORTANT

- (1) Do not move the tractor with the parking brake on.
- (2) Do not operate the tractor with your foot resting on the clutch pedal. This will cause premature clutch wear.
- (3) Gear shift levers cannot be shifted while the tractor is moving. To shift levers be sure to stop the tractor and depress the clutch pedal.

### ■ Stopping

- (1) Slow the engine down.
- (2) Step on the clutch and brake pedal.
- (3) After the tractor has stopped, disengage the PTO, lower the implement, shift the transmission to neutral, release the clutch pedal, pull the parking rod to apply the parking brake.

### ■ Parking

- (1) When parking, be sure to apply the parking brake.
- (2) Before getting off the tractor, disengage the PTO, lower all implements, place all control levers in their neutral positions, set the parking brake, stop the engine and remove the key.
- (3) If it is necessary to park on an incline, be sure to chock the wheels to prevent accidental rolling of the machine.

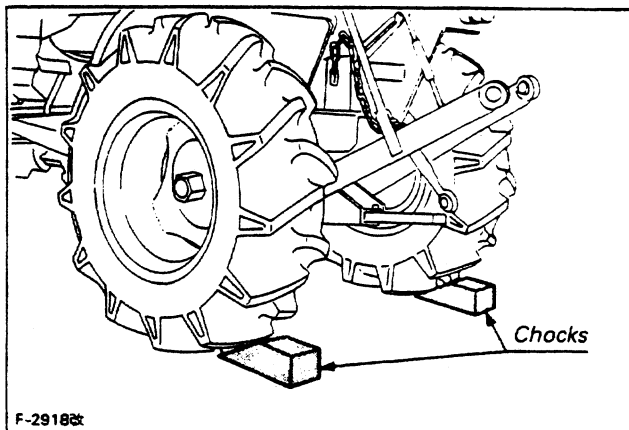

### CAUTION

- Always set the parking brake and stop the engine before leaving the tractor seat.

## 8.3 PULLING



### CAUTION

- Never pull from the top link, the rear axle or any point above the drawbar. Doing so could cause the tractor to tip over rearward causing personal injury.
- For pulling, attach only to the drawbar. Use the 3-point hitch only with equipment designed for 3-point hitch usage.

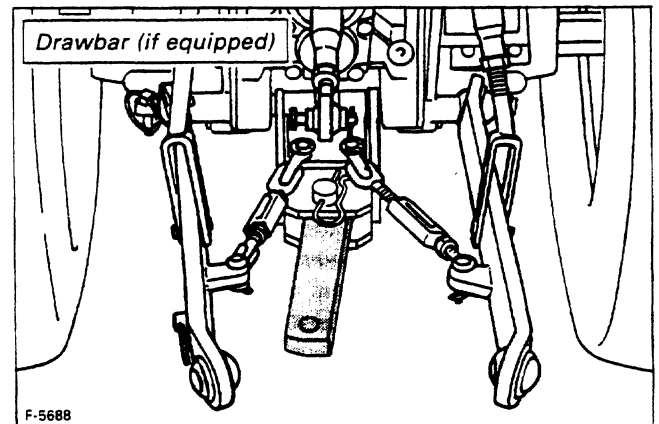

## 8.4 CHECK DURING DRIVING

While driving, make the following checks to see that all the parts are functioning normally.

### ■ Coolant



### CAUTION

To avoid personal injury;

- Do not remove radiator filler cap until coolant temperature is well below its boiling point. Then rotate cap slightly to the stop to relieve any excess pressure before removing cap completely.

If engine temperature gauge needle moves into the red zone on the gauge, stop the engine and check for the following:

- (1) Shortage or leakage of the coolant.
- (2) Foreign matter on the radiator net and dust and dirt between the radiator fins and tube.
- (3) Loose fan drive belt.
- (4) Internal blockage in the radiator core or hose.



## ■ Easy Checker

### ↳ Engine oil pressure light

The pressure light signals the operator that the engine oil pressure is below the prescribed level. If the light goes on during operation, immediately stop the engine and check the following:

- (1) The level of the engine oil. (See page 33)
- (2) The conditions of the lubrication system.

### ● Battery charge light

The charge light signals to the operator that the alternator is not charging the battery.

If the light goes on during operation, immediately stop the engine and check for:

- (1) Wiring failure.
- (2) Connection failure of alternator and regulator.
- (3) Alternator drive belt failure.

## ■ Fuel

Do not allow the fuel tank to empty completely.

Doing so will allow air to enter into the fuel system. Should this happen, the fuel system must be bled. (See page 32)

## ■ Exhaust Fumes

- (1) Exhaust fumes are colorless at normal output drive.
- (2) If the color of exhaust gas becomes dark often during driving, the engine may be overloaded. This will result in excessive wear to the engine, drivetrain, and tires. Operate in a lower gear or decrease load placed on tractor.

## ■ Urgent Stop

Should the following take place, immediately stop the engine.

- (1) The engine suddenly slows down or speeds up.
- (2) Unusual noises are suddenly heard.
- (3) Exhaust fumes suddenly become very dark.
- (4) The engine oil pressure light illuminates while operating.
- (5) The battery charge light goes on while operating.

For checks and remedies in the above situations, consult your Kubota dealer.

## 8.5 DIRECTIONS FOR OPERATING

### ■ Differential Lock Pedal

Observe the following precautions when applying the differential lock.

- (1) Apply the differential lock moderately. Limit its use to the following situations.
  - When the tractor enters or leaves the farm field, it cannot move straight because of excessive individual wheel-spin under difficult or slippery field conditions.
  - One rear wheel is caught in a loose area of the field and the tractor cannot move due to wheel-spin.
  - In the case of plowing, the rear wheel closer to the ridge is caught in the loose soil and is affected by wheel-spin.
- (2) The use of the differential lock must be limited to a particular period of time and should not be applied continuously.
- (3) When the rear wheel is subjected to excessive loads, even releasing the pedal sometimes may not unlock the differential although the pedal springs back. Should the differential not unlock when turning the tractor, lightly step on the brake pedal opposite to the turn side or turn back the steering wheel and run the tractor straight. By doing so, the differential can be unlocked. If the brake pedal of the turn side is depressed during turning, the differential lock system takes on an undue load. Avoid such improper operation.



### CAUTION

- Do not turn the tractor with differential lock-on, as it is very dangerous.

# 9. MAINTENANCE

## 9.1 DAILY CHECK

To prevent trouble from occurring, it is important to know the tractor well.



### CAUTION

To avoid personal injury;

- Be sure to check and service the tractor on a flat area with the engine shut off and the parking brake on.

Checks before starting:

- (1) Check areas where previous trouble was experienced.
- (2) Walking around the tractor:
  - 1) Check the tire pressure, and check for wear and damage. (See page 25,26)
  - 2) Check for oil and water leaks.
  - 3) Check the engine oil level.  
(See page 33)
  - 4) Check the amount of transmission fluid.  
(See page 34)
  - 5) Check the fuel level. (See page 32)

- 6) Check the coolant level. (See page 38)
- 7) Check and clean the radiator screen.  
(See page 39)
- 8) Check the tractor body for damage and all bolts and nuts for looseness.
- 9) Check the SMV emblem and labels for damage and clean or replace as necessary.
- (3) While sitting in the operator's seat;
  - 1) Check the throttle pedal, brake pedals and clutch pedal. (See page 42)
  - 2) Check the parking brake.
  - 3) Check the steering wheel. (See page 43)
- (4) Turning the key switch on;
  - 1) Check the performance of the easy checker lights.
  - 2) Check headlights, tail lights and hazard light, clean if necessary.
- (5) Starting the engine;
  - 1) Check the color of the exhaust fumes.

## 9.2 LUBRICANTS

To prevent serious damage to hydraulic systems, use only genuine KUBOTA fluid or its equivalent.

Place	Capacity	Lubricants
Engine crankcase	3.1 l (3.3 U.S.qts.)	<ul style="list-style-type: none"> <li>● Engine oil: API Service CC or CD</li> <li>Below 0°C (32°F) SAE10W or 10W-30</li> <li>0 to 25°C (32 to 77°F) SAE20 or 10W-30</li> <li>Above 25°C (77°F) SAE30 or 10W-30</li> </ul>
Transmission	13.5 l (14.3 U.S.qts.)	See page 48.
Front axle differential case (4WD)	B1550 HST 0.5 l (0.5 U.S.qt.)	<ul style="list-style-type: none"> <li>● Gear oil SAE80 or SAE90</li> </ul>
	B1750 HST 1.5 l (1.6 U.S.qts.)	
	Bi-Speed Turn 2.5 l (2.6 U.S.qts.)	
Front axle gear case (Right & left) (4WD)	B1550 HST 0.15 l (0.15 U.S.qt.)	<ul style="list-style-type: none"> <li>● Gear oil SAE80 or SAE90</li> </ul>
	B1750 HST 0.5 l (0.5 U.S.qt.)	
Steering gear box (Manual steering)	0.2 l (0.2 U.S.qt.)	<ul style="list-style-type: none"> <li>● Gear oil SAE80 or SAE90</li> </ul>
King pins (2WD) Center pin (2WD) Pedal shaft Clutch release hub Seat adjuster Speed control pedal shaft	moderate amount	<ul style="list-style-type: none"> <li>● SAE multi-purpose type grease</li> </ul>

## 9.3 MAINTENANCE CHECK LIST

No.	Check point	Indication on hour meter (Change or check every interval shown below)							(After purchase)		Reference Page
		50	100	200	300	400	500	600	1 year	2 year	
1	Engine oil change	⊙	○	○	○	○	○	○			34
2	Engine oil filter cartridge replacement	⊙		○		○		○			34
3	Transmission fluid change		⊙		○			○			34
4	Transmission oil filter cartridge replacement	⊙			○			○			35
5	Transmission strainer cleaning		⊙		○			○			35
6	Front axle differential case oil change				○			○			35,36
7	Front axle gear case (right and left) oil change				○			○			36
8	Clutch pedal play range check		○	○	○	○	○	○			42
9	Brake pedal play range check		○	○	○	○	○	○			43
10	Steering wheel play range check		○	○	○	○	○	○			43
11	Battery electrolyte level check		○	○	○	○	○	○			40
12	Recharge battery	Every one to two months									40,41
13	Radiator hose and hose clamp check			○		○		○			38
14	Fan drive belt tension check	⊙		○		○		○			42
15	Fuel filter cleaning		○	○	○		○	○			33
16	Fuel filter replacement					○					33
17	Radiator cleaning								○		38,39
18	Anti-freeze and coolant change								○		38,39
19	Fuel line check		○	○	○	○	○	○			32
20	Fuel line replacement									○*	32,33
21	Radiator hose replacement									○*	38
22	Hydraulic hose change									○	—
23	Air cleaner element cleaning		○	○	○	○	○				39
24	Air cleaner element replacement							○**			39
25	Greasing King pins, Pedal shaft, Center pin, Speed control pedal shaft Clutch release hub		○	○	○	○	○	○			36,37

Note: The jobs indicated by ⊙ must be done at 50 and 100 hours respectively.

\* Replace only if necessary.

\*\* Every year or every 6 times of cleaning.

### IMPORTANT

- Air cleaner should be cleaned more often in dusty conditions than in normal conditions.

Suggested cleaning interval is every 100 hours in normal conditions. Follow the cleaning procedures.

# 10. CHECK AND MAINTENANCE

## 10.1 FUEL

### ■ Checking and Refueling



#### CAUTION

To avoid personal injury;

- (1) Stop the engine before adding fuel. Keep away from sparks and flames.
- (2) Allow engine to cool before refueling.

- (1) Check the fuel level. Take care that the fuel level should not fall under the prescribed lower limit.

Fuel tank capacity	18 l (4.8 U.S.gals.)
--------------------	----------------------

- (2) Use diesel fuel No.2-D.
- (3) Use No.1 diesel fuel, if temperature is below  $-10^{\circ}\text{C}$  ( $14^{\circ}\text{F}$ ).

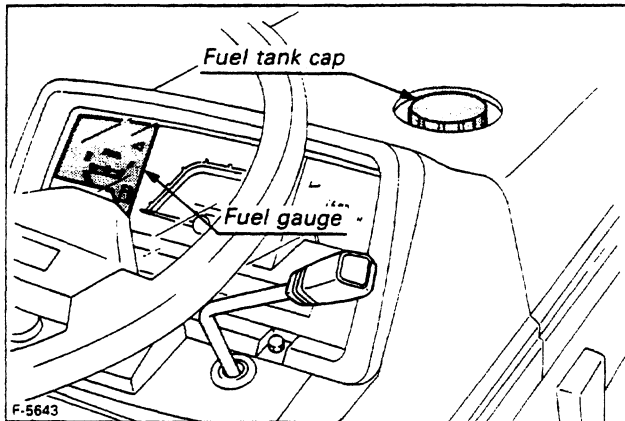

#### IMPORTANT

- (1) Always use a strainer when refueling to prevent dirt from entering fuel system.
- (2) Once the fuel tank becomes empty, air is admitted to the fuel system. It will then be necessary to bleed the fuel system before the engine will start.

### ■ Fuel Line Bleeding

Air must be removed:

- (1) When the fuel filter or lines are removed.
- (2) When tank becomes completely empty.
- (3) When the tractor has not been used for a long period of time.

Bleeding procedure is as follows:



#### CAUTION

- Do not bleed the fuel system when the engine is hot. Fuel may contact hot engine parts resulting in serious personal injury or death from fire.

- (1) Fill the fuel tank with fuel, and open the fuel cock.

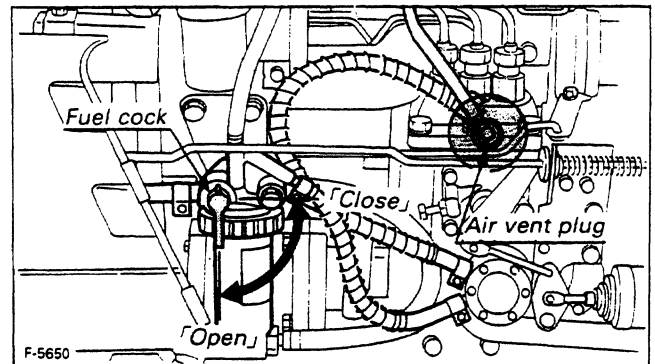

- (2) Open the air vent plug on the fuel injection pump.
- (3) Pull the engine stop knob back completely to prevent the engine from starting while turning the key to rotate the engine for about 10 seconds.



#### CAUTION

- For the above procedure, pull out the engine stop knob before engaging the starter.

- (4) Close the air vent plug.

#### IMPORTANT

- Always close the air vent cock except for bleeding fuel lines. Otherwise, engine will run irregularly or stop frequently.

### ■ Checking Fuel Line



#### CAUTION

To avoid personal injury;

- (1) Stop the engine when attempting to check and change as prescribed below.
- (2) Never fail to check the fuel line periodically. The fuel line is subject to wear and aging, fuel may leak out onto the running engine, causing a fire.

Check the fuel line connections every 100 service hours or every 6 months, whichever occurs first.

- (1) If the clamp is loose, apply a slight coat of lubricant onto the threads and securely retighten it.

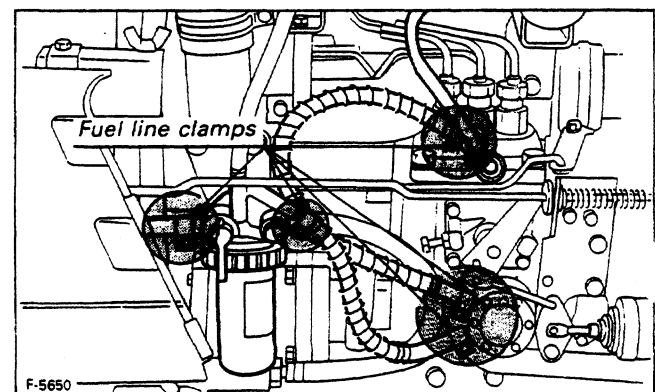

- (2) The fuel line is made of rubber and will age. Change the fuel line and clamp whenever worn or damaged.
- (3) After the fuel line and clamp have been changed, bleed the fuel system.

#### IMPORTANT

- When the fuel line is disconnected, close both ends of the fuel line with a piece of clean cloth or paper to prevent dust and dirt from entering the fuel system. Entrance of dust and dirt causes malfunction of the fuel injection pump. Extra care must be taken not to admit dust and dirt into the fuel pump.

#### ■ Cleaning the Fuel Filter Bowl

When operation period reaches approx. 100 hours, clean the fuel filter.

This job should not be done in the field, but in a clean place so as to prevent dust from entering fuel system.

- (1) Unscrew the wing bolt and knob bolt which fasten the engine cover RH, and remove the cover.
- (2) Close the fuel filter bowl cock.

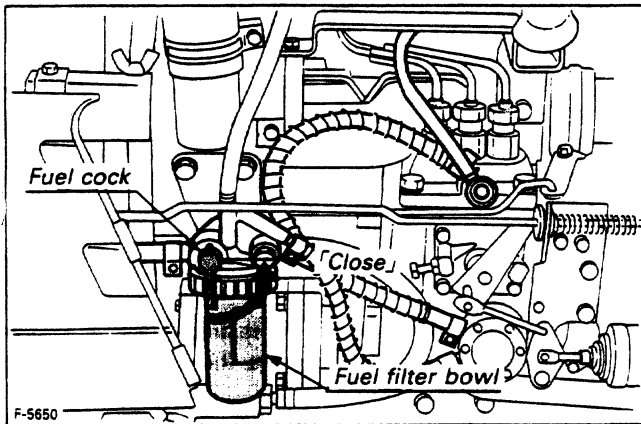

- (3) Unscrew and remove the screw ring, and rinse the inside with kerosene.
- (4) Take out the element and dip it in the kerosene to rinse.

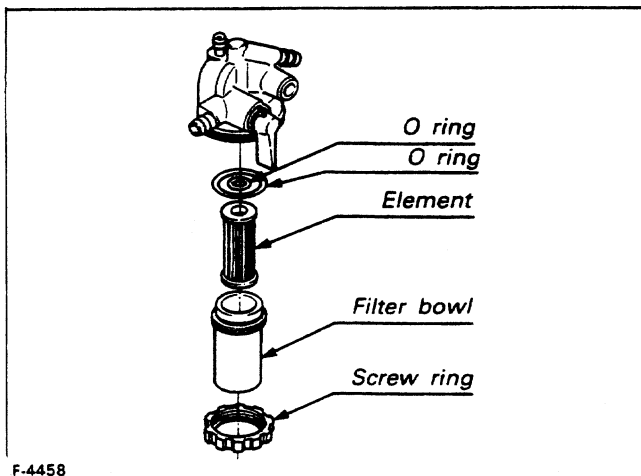

- (5) After cleaning, reassemble the fuel filter, keeping out dust and dirt.
- (6) Bleed the injection pump.

#### IMPORTANT

- If dust and dirt enter the fuel, the fuel pump and injection nozzles are subject to wear. To prevent this, be sure to clean the fuel filter bowl periodically.

## 10.2 ENGINE OIL

#### ■ Oil Level Check and Replenishment

(See page 30, 48)

- (1) Check engine oil before starting the engine or 5 minutes or more after the engine has stopped.
- (2) To check the oil level, remove the dipstick, wipe it clean, replace it, and remove it again. Check that the oil level is between the two notches.
- (3) If the level is too low, add new oil to the recommended level.

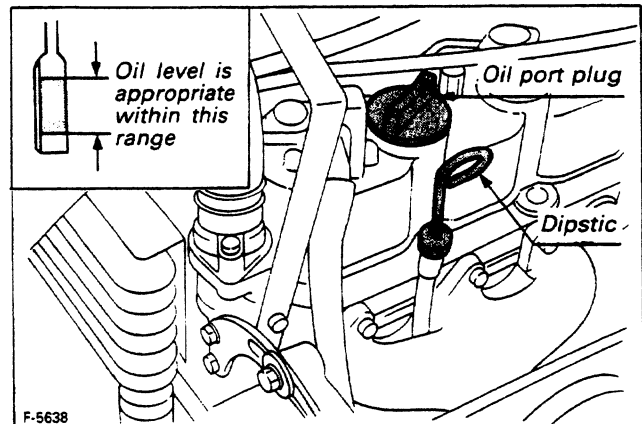

- (4) When using an oil of different manufacturer or viscosity from the previous one, remove all of the old oil. Never mix two different types of oil.
- (5) Use the proper SAE Engine Oil according to the air temperatures.  
Refer to 9.2 "LUBRICANTS"

## ■ Engine Oil Change



### CAUTION

- Before changing the oil, be sure to stop the engine.

- (1) To change the used oil, remove the drain plug at the bottom of the engine and drain the oil completely. All the used oil can be drained out easily when the engine is still warm.

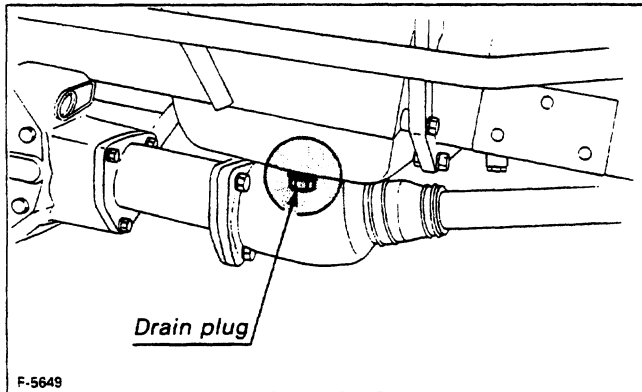

- (2) Reinstall the drain plug.
- (3) Fill with the new oil up to the upper notch on the dipstick.

## ■ Engine Oil Filter Cartridge Change



### CAUTION

- Be sure to stop the engine before changing the oil filter cartridge.

- (1) The oil filter cartridge must be changed every 200 service hours.
- (2) Unscrew the wing bolt and knob bolt which fasten the cover LH, and remove the cover LH.
- (3) Apply a slight coat of oil onto the cartridge gasket.
- (4) To install the new cartridge, screw it in by hand. Over tightening may cause deformation of rubber gasket.
- (5) After the new cartridge has been replaced, the engine oil normally decreases a little. Check for leaks and refill if necessary.

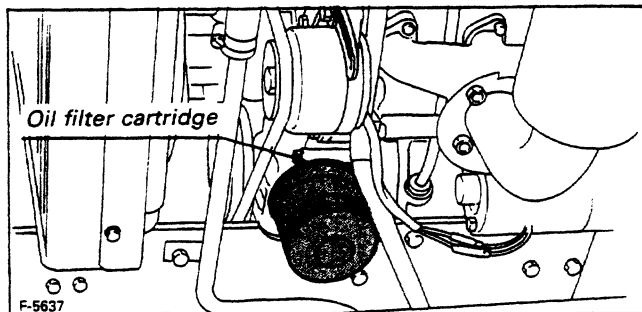

### IMPORTANT

- To avoid serious damage to the engine, replacement element must be of high quality. Use only a genuine KUBOTA filter or its equivalent.

## 10.3 TRANSMISSION FLUID



### CAUTION

- Be sure to stop the engine before checking and changing the transmission fluid.

### ■ Transmission Fluid Check and Replenishment

To check the oil level, remove the dipstick, wipe it clean, replace it, and remove it again. Check that the oil level is between the two notches.

If low, replenish through the port.

Use multi-grade transmission fluid. (See page 48)

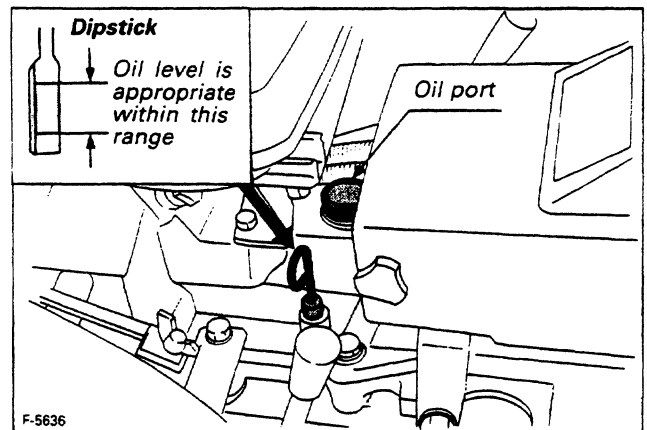

### ■ Transmission Fluid Change

The fluid in the transmission case is also used for the hydraulic system.

To drain the transmission case, place an oil pan underneath the transmission case and remove the drain plug at the bottom of the transmission case.

After draining, disassemble and clean the transmission strainer. After reassembling, fill with new multi-grade transmission fluid.

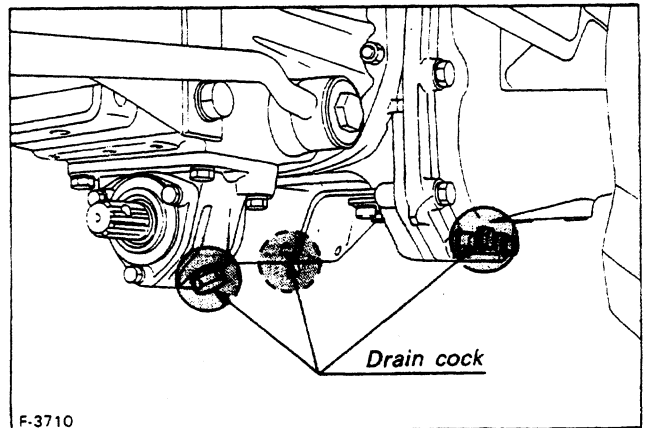

### IMPORTANT

- Never operate the tractor immediately after changing transmission fluid and the transmission filter. Keep the engine at medium speed for a few minutes to prevent the damage to the transmission.

## ■ Transmission Oil Filter Cartridge Change



### CAUTION

- Be sure to stop the engine before changing the oil filters.

- (1) The oil filter cartridge must be changed every 300 service hours.
- (2) Remove the 4 bolts which secure the cover.
- (3) Remove the oil filter cartridge by using a filter wrench.
- (4) Lightly tighten the screw **A** by using a screwdriver.
- (5) Apply a slight coat of oil onto the cartridge gasket.
- (6) To install the new cartridge, screw it in by hand. Over tightening may cause deformation of rubber gasket.
- (7) After the new cartridge has been replaced, the transmission fluid level will normally decrease slightly. Make sure that the transmission fluid does not leak through the seal. Check the fluid level.

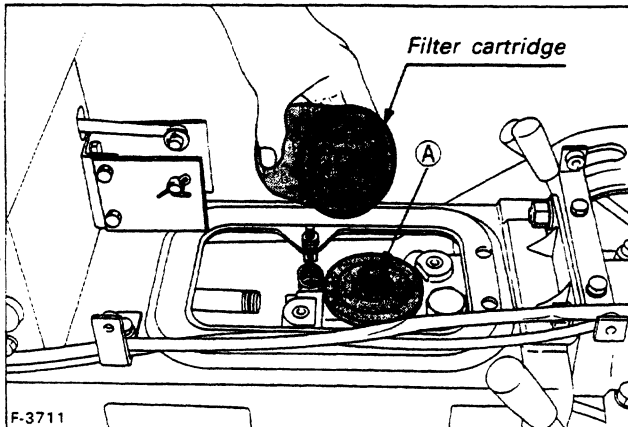

### IMPORTANT

- (1) To prevent serious damage to the hydraulic system, the replacement filter must be a highly efficient, 10  $\mu$  m filter. Use only a genuine KUBOTA filter or its equivalent.
- (2) When using the auxiliary hydraulics, replace the transmission oil filter cartridge after initial 50 service hours.

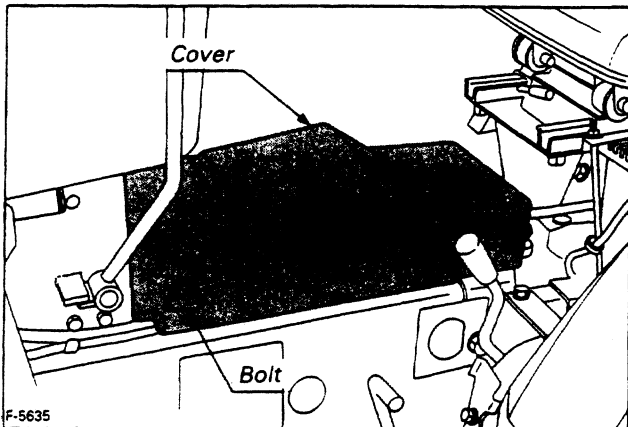

## ■ Cleaning Strainer

Since the fine filings in the oil could impair the component parts of the hydraulic system precision built to withstand high pressure, the suction line end is provided with an oil strainer. When changing the transmission fluid, disassemble and rinse the strainer with kerosene to completely clean off filings. When reassembling be careful not to damage the parts.

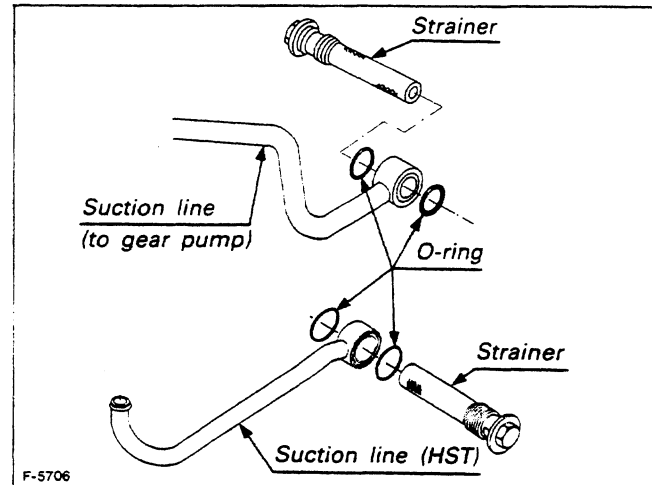

## 10.4 CHANGING FRONT AXLE DIFFERENTIAL CASE OIL (4WD) (See page 30)

Remove the drain and filling port plug. After draining, replace the drain plug and fill with new oil.

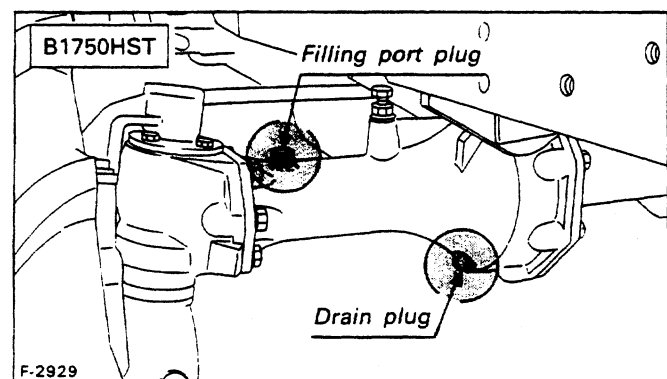
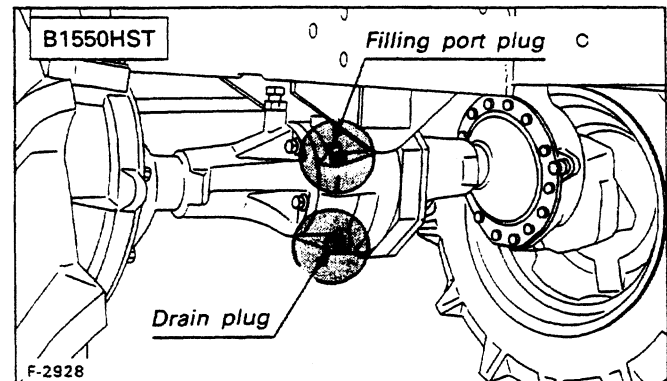

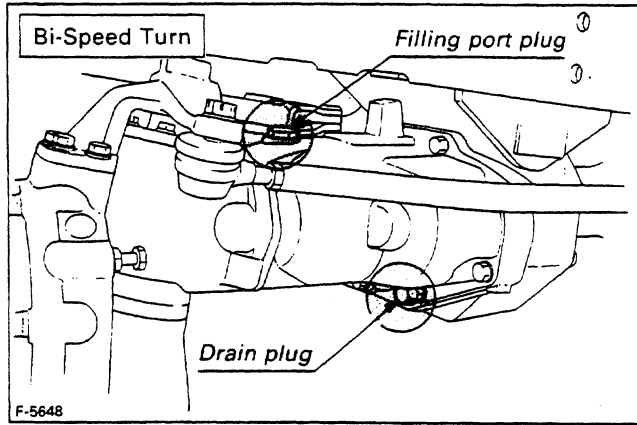

### 10.5 CHANGING FRONT AXLE GEAR CASE OIL

(RIGHT AND LEFT) (4WD) (See page 30)

Remove the drain and filling port plugs to drain the used oil. After draining, replace the drain plug and fill with new oil.

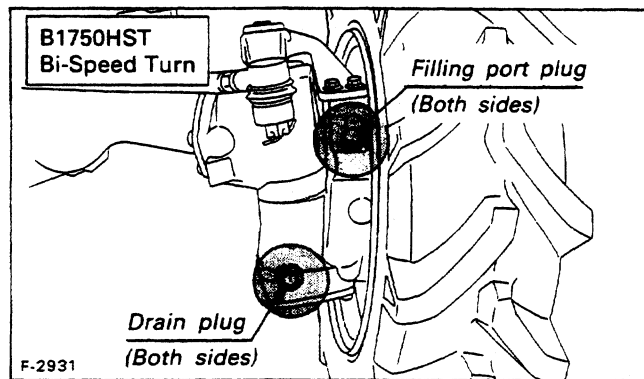
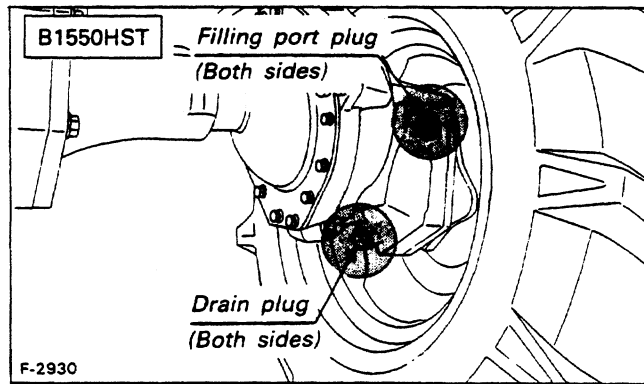

### 10.6 STEERING GEAR BOX OIL

(See page 3)

— Manual Steering Only —

If the oil level is low, fill with gear oil up to the oil inlet port.

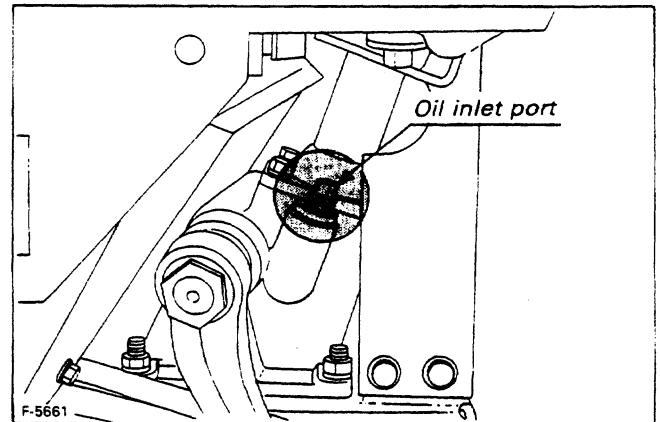

### 10.7 OILING AND GREASING POINTS BEFORE STARTING

Oil or grease the following points before starting.

■ King Pins (2WD) and Center Pin (2WD)

Grease the king pins and center pin with grease gun.

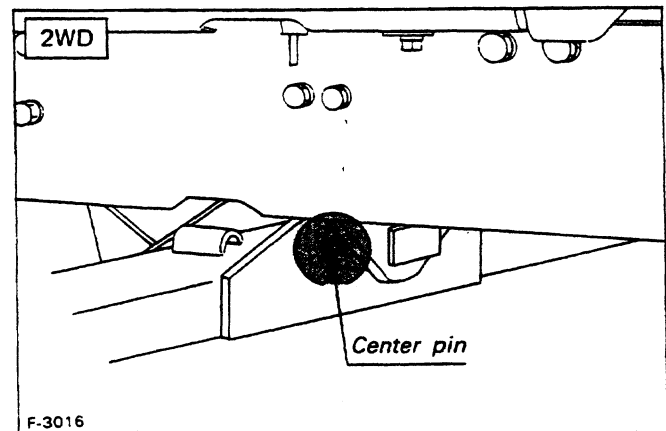
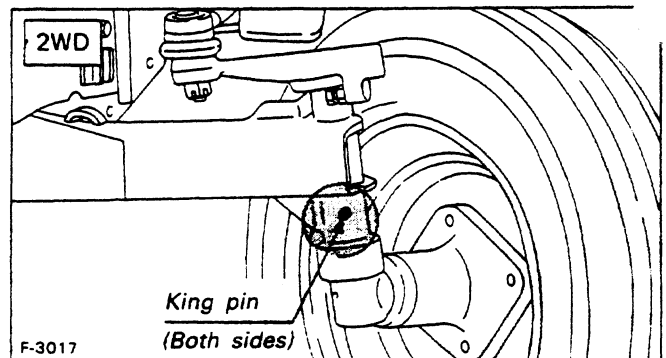



■ Pedal Shaft

Grease on both ends of the brake pedal shaft and the speed control pedal shaft.

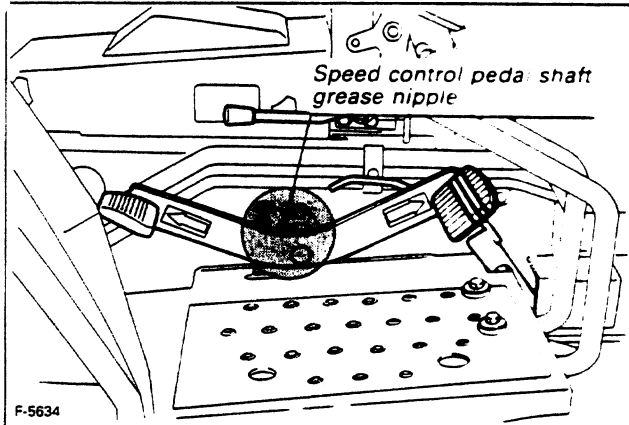
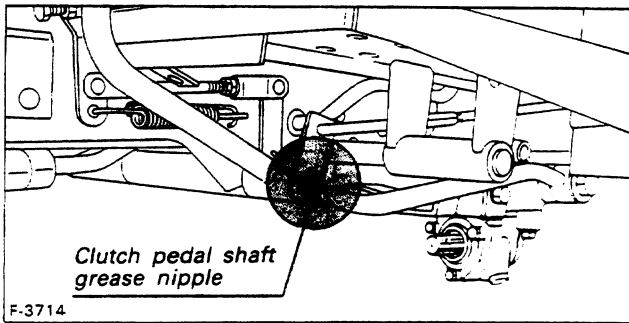
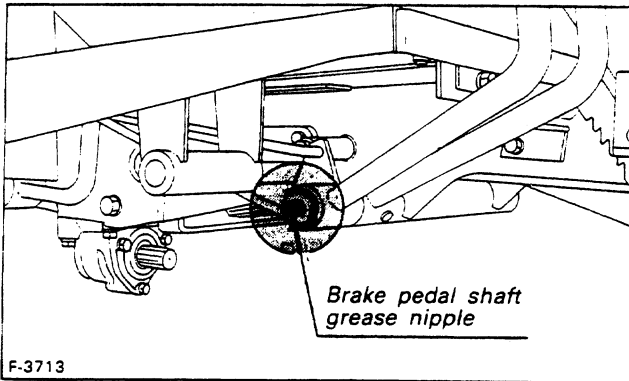

■ Clutch Release Hub

Sparsingly lubricate the clutch release hub (throwout bearing). Too much grease will adversely effect the clutch performance.

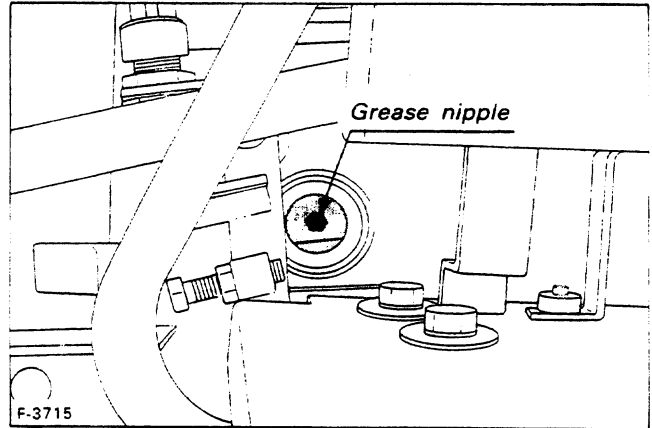

■ Seat Adjuster

Apply grease to the sliding guide surface.

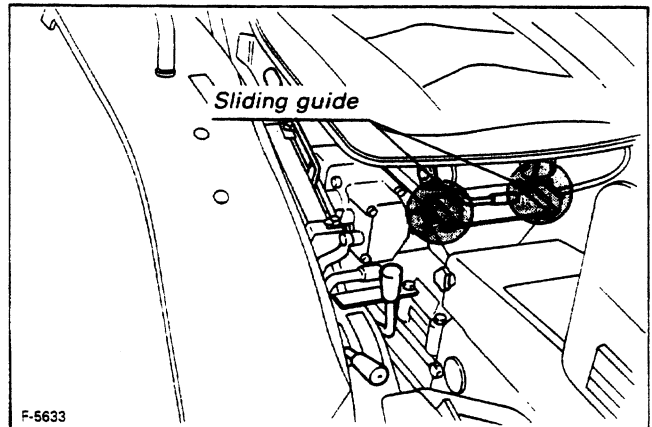

## 10.8 RADIATOR



### CAUTION

To avoid personal injury:

- Do not remove radiator filler cap until coolant temperature is well below its boiling point. Then rotate cap slightly to the stop to relieve any excess pressure before removing cap completely.

### ■ Checking, Replenishing and Changing Coolant

- (1) Remove the radiator cap and check to see that the coolant level is just below the port. If low, add clean water and anti-freeze solution.

Prescribed quantity	B1550HST	2.9 l (3.1 U.S.qts.)
	B1750HST	3.5 l (3.7 U.S.qts.)

### IMPORTANT

- (1) Use clean, fresh water and anti-freeze to fill the radiator.
- (2) Securely tighten the radiator cap.

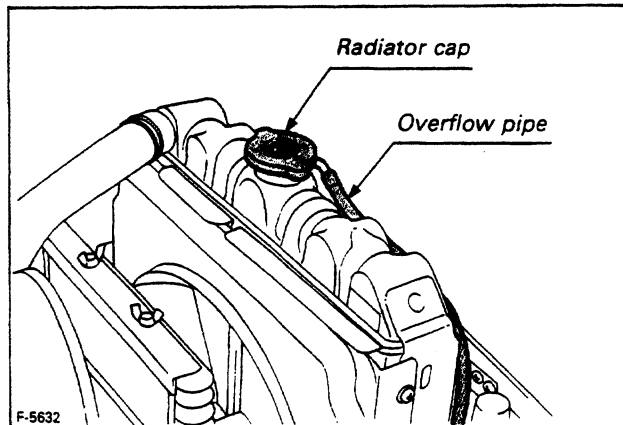

- (2) To drain the used coolant, open the radiator drain cock and remove radiator cap. The radiator cap must be removed to completely drain the radiator.

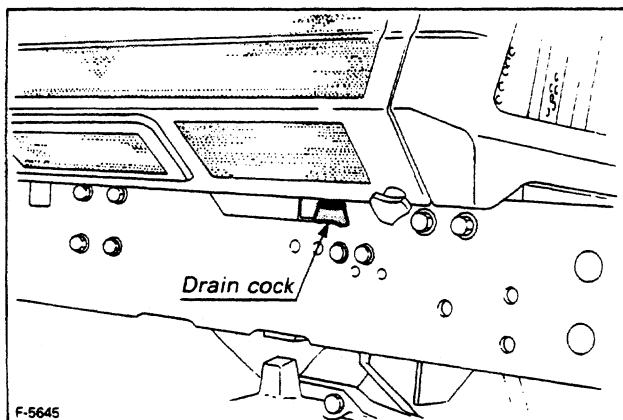

- (3) Be sure to close the radiator cap securely. If the cap is loose or improperly closed, water may leak out and engine could overheat.
- (4) Radiator should be filled with 50/50 solution of anti-freeze and water at all times as recommended by the anti-freeze manufacturer. The anti-freeze contains a corrosion inhibitor and will allow a higher operating temperature in the radiator during the hot season.
- (5) Do not use an anti-freeze and scale inhibitor at the same time.

### ■ Checking Radiator Hose

Checking radiator hose clamp tightness is recommended at every 200 service hours or every 6 months, whichever occurs first.

- (1) If the clamp is loose, apply a slight amount of oil and securely retighten.
- (2) The radiator hose is made of rubber and tends to deteriorate with age. Check hoses and clamps every six months and replace if damaged or aged.

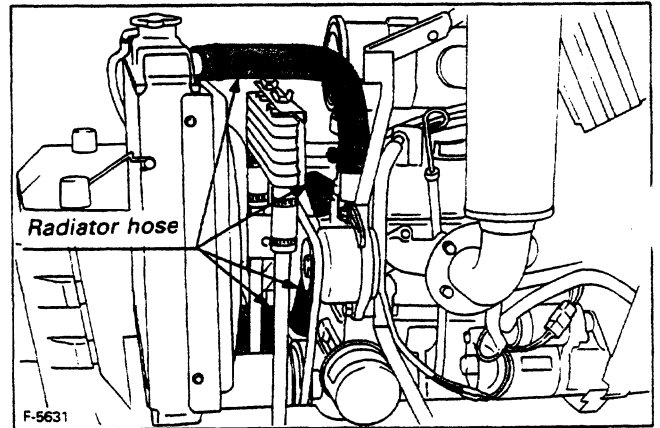

### ■ Water Leakage Remedy

- (1) A small water leak can be eliminated with the Kubota Radiator Cement No.40 or equivalent.
- (2) If water leakage should become excessive, consult your local dealer.

### ■ Cooling System Cleaning

- (1) The water cooling system should be cleaned on the following occasions:
  - Every year service hours
  - When adding an anti-freeze solution.
  - When changing from water containing anti-freeze to pure water.
- (2) When cleaning the water cooling system, Kubota Scale Inhibitor No.20, or its equivalent, is recommended to effectively flush scale build-up.

### ■ Anti-Freeze

the cooling water freezes, the engine cylinder block and radiator may crack. In cold weather before the temperature drops below 0°C (32°F), add a proper amount of anti-freeze to the tractor coolant system.

- (1) Use only permanent type antifreeze in recommended proportions for your area.
- (2) When the coolant mixed with anti-freeze decreases due to evaporation, replenish with water only. If loss has been due to leaking, add water and anti-freeze mixture with the same mix ratio as the original preparation.
- (3) Anti-freeze and water should be changed every year.
- (4) Do not use an anti-freeze and a scale inhibitor at the same time. This may cause sludge to form, adversely affecting the engine parts.

### ■ Checking and Cleaning Radiator and Oil Cooler to prevent overheating

Daily or every 5 hours of operation, check whether the radiator screen, radiator core and oil cooler core are clean. Dirt or chaff to the radiator screen, radiator core, or oil cooler core decreases cooling performance.

- (1) In that case, detach the screen and remove all the foreign materials from them.

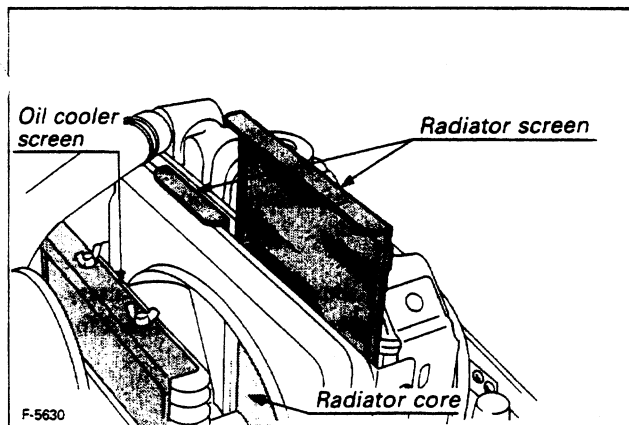

- (2) Remove the dust and dirt from between the fins and the tube using water or compressed air.
- (3) Tighten the fan drive belt as necessary. For instructions, refer to page 42.
- (4) If scale forms in the tube, clean with scale inhibitor or equivalent.

## 10.9 AIR CLEANER

- (1) The air cleaner is a dry element type, never apply oil.
- (2) Do not touch the filter element except in cases where cleaning is required.
- (3) When cleaning this element, refer to the instructions below.
- (4) If the element is saturated with carbon or oil, replace the filter.
- (5) Be careful when cleaning the air filter element, mishandling will damage the element and cause serious problems to the engine.
- (6) Change the element once a year or after every sixth washing, whichever comes first.

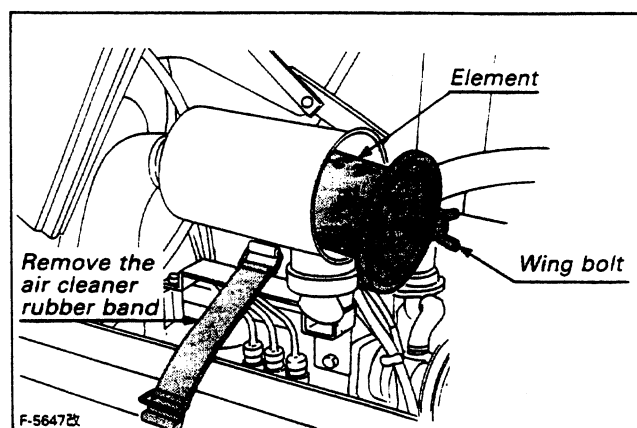

### IMPORTANT

- Do not run the engine with filter elements removed.

## 10.10 CLEANING AIR FILTER ELEMENT

To clean the element, use clean dry compressed air on the inside of the element.

Air pressure at the nozzle must not exceed 205 kPa (2.1 kgf/cm<sup>2</sup>; 30 psi).

Maintain reasonable distance between the nozzle and the filter.

## 10.11 BATTERY



### CAUTION

To avoid personal injury:

- (1) Never remove the battery cap while the engine is running.  
Keep electrolyte away from eyes, hands and clothes. If you are spattered with it, flush it away completely with water immediately.
- (2) Wear eye protection and rubber gloves when working around batteries.

Mishandling the battery shortens the service life and adds to maintenance costs.

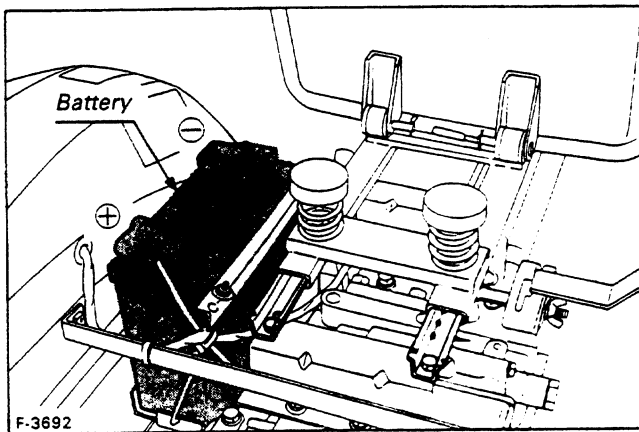

### CAUTION

● When the battery is being activated, hydrogen and oxygen gases in the battery are extremely explosive. Keep open sparks and flames away from the battery at all times, especially when charging the battery.

- (1) If the battery is weak, the engine will be difficult to start and the lights will become dim. It is important to check the battery daily and recharge before trouble occurs.
- (2) The water in the electrolyte evaporates during recharging. Liquid shortage damages the battery. Excessive liquid spills over and damages the tractor body. If low, fill the battery with distilled water.

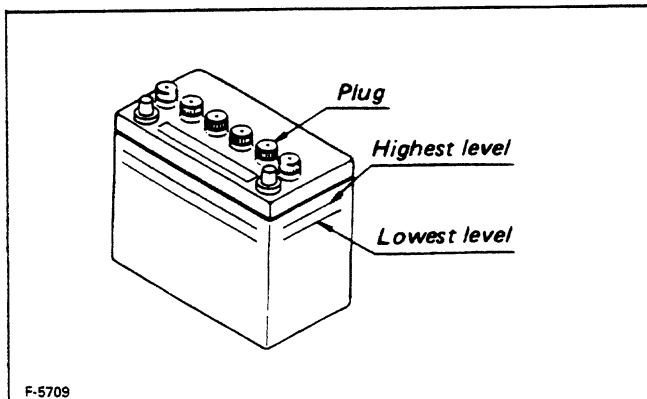

- (3) To slow charge the battery, connect the battery positive terminal to the charger positive terminal and the negative to the negative, then recharge in the standard fashion.
- (4) A boost charge is only for emergencies. It will partially charge the battery at a high rate and in a short time. When using a boost-charged battery, it is necessary to recharge the battery as early as possible. Failure to do this will shorten the battery's service life.



### CAUTION

● To avoid accidental short circuit and injury, be sure to attach the positive cable to the positive terminal before the ground cable is attached to the negative terminal.

### IMPORTANT

- If the tractor is to be operated for a short time without a battery (using a slave battery for starting), do not, under any circumstances, interrupt the circuit by switching off the key switch before stopping the engine by means of fuel pump shut-off knob. Use additional current (lights) while engine is running. Insulate terminal of battery cable before starting by means of slave battery. If this advice is disregarded, damage to alternator and regulator may result.

### ■ Directions for Storage

- (1) When storing the tractor for long periods of time remove the battery from the tractor, adjust the electrolyte to the proper level and store in a cool, dry place.
- (2) The battery self-discharges while it is stored. Recharge it once a month in hot seasons and once every two months in cold seasons.

### IMPORTANT

- The tractor has been shipped with a dry battery. Your dealer will fill it with electrolyte and charge it for initial use.

### ■ Dry Type Battery Charging

- (1) Remove vent plugs and discard temporary sealing tapes.
- (2) Fill each cell with electrolyte having a specific gravity given in Table 1 up to the middle levels marked on the battery case side.

Table 1

	AIR TEMPERATURES	
	TEMPERATE Ordinarily below 20°C (68°F)	TROPICAL Frequently above 20°C (68°F)
sp.gr. of Electrolyte for Filling	1.260	1.240
sp.gr. of Electrolyte when fully charged	1.260 to 1.275	1.240 to 1.255

- (3) After standing 2 to 3 hours, adjust the electrolyte to proper level.
- (4) Connect positive terminal  $\oplus$  of battery, with positive terminal of D.C. charging unit, and negative terminal  $\ominus$  with negative terminal.
- (5) Batteries are preferably charged by the current shown in Table 2. Keep vent plugs removed during charging.

Table 2

TYPE	Volts (V)	Number of plate per cell	Capacity at 20 H.R (A.H)	Volume of Electrolyte (ℓ)	Normal Charging Rate (A)
50B24L	12	13	45	2.8	4.5

- (6) Check temperature of electrolyte, if it reaches 40°C (105°F), lower the charging rate. When the temperature is too high, reduce charging rate and charge for a longer period.
- (7) If the tractor is stored after original charge, periodically recharge as shown below:

Table 3

Period of storage from manufactured (months)	Recharge (hours)
0 to 6	about 3 to 5 hours
6 to 12	10
over 12	30

A battery is fully charged when the cells are all gassing freely and the specific gravity ceases to rise for three consecutive readings taken at hour intervals. Specific gravity should be adjusted to that shown in Table 1.

- (8) Check electrolyte level two hours after charging has finished and correct if necessary by adding distilled water.

## 10.12 BULB REPLACEMENT

- (1) Hold the socket with your hand. Push and turn it counterclockwise. Now the socket can be pulled out. (Fig. 1 and 2)
- (2) Replace the old bulb with a new one. (Fig. 3) Match the white marks. (Fig. 4)
- (3) Set in the socket, matching the above two marks with the on-body white mark. (Fig. 5)
- (4) Keeping the socket pressed, turn it clockwise into position. (Fig. 6)

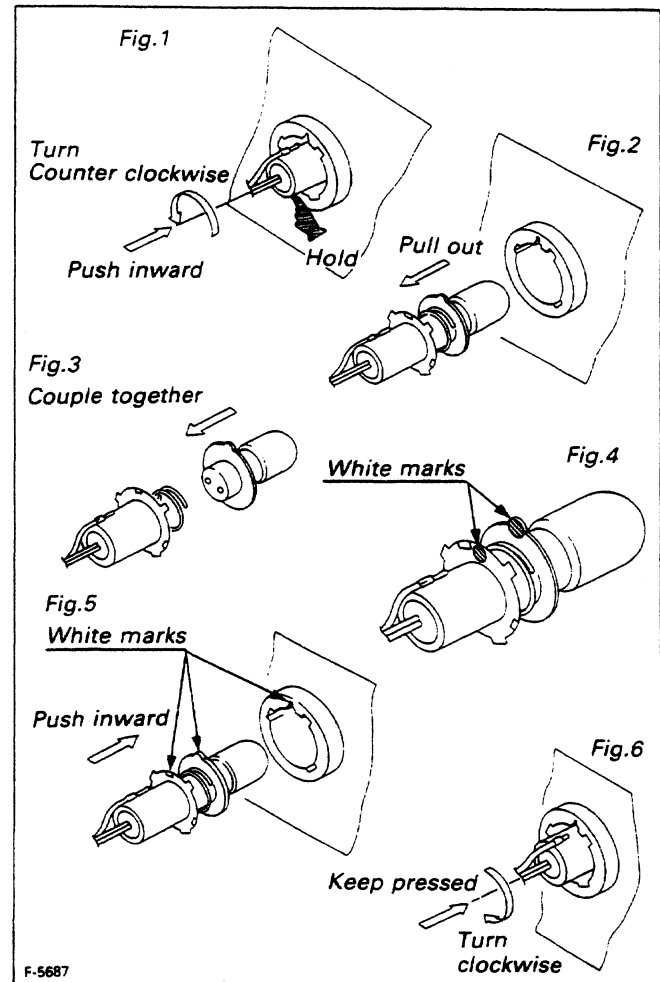

# 11. ADJUSTMENTS



## CAUTION

To avoid possible tractor run away;

- While making adjustments, park the tractor on a firm level surface, set the parking brake, place the gear shift lever in neutral and stop the engine.

## 11.1 FAN DRIVE BELT

### [A TYPE]

If the fan drive belt becomes loose, the engine may overheat.

Check the belt tension as shown below.

To adjust, loosen the adjusting bolt and tension bolt to stretch the belt. After adjustment, securely tighten the adjusting bolt.

Moderate belt tension:

The belt should deflect approx. 10 mm (0.4 in.) when the center of the belt is depressed with a finger pressure of 98N (10kgf, 22lbs.).

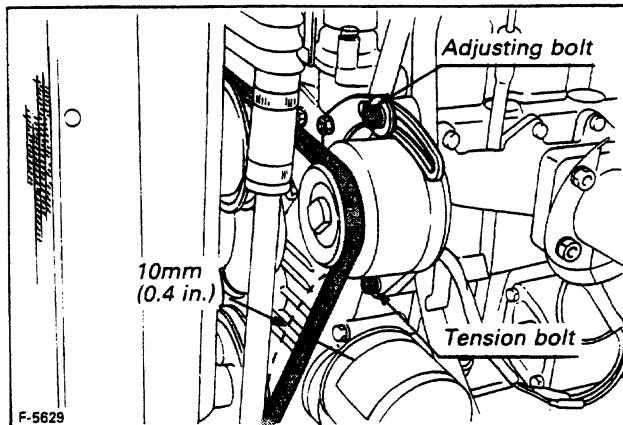

### [B TYPE]

If the fan drive belt or the dynamo drive belt becomes loose, the engine may sometimes overheat, or the battery may not be charged. When the fan drive belt is deflected excessively, loosen the adjusting nut and tighten the tension bolt to stretch the belt. After the adjustment, be sure to tighten the adjusting nut. When the dynamo drive belt is loose, loosen the bolts and turn the dynamo to stretch the belt. Finally, tighten up the three bolts.

Moderate belt tension:

The belt should deflect approx. 10mm (0.4 in) when the center of the belt is depressed with a finger pressure of 98N (10kgf, 22lbs.).

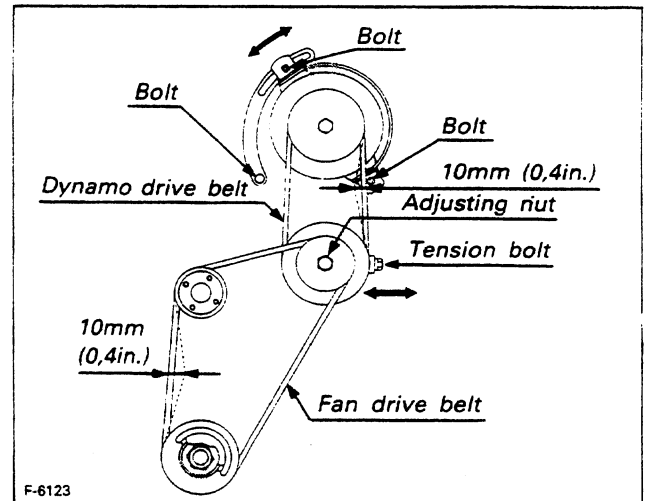
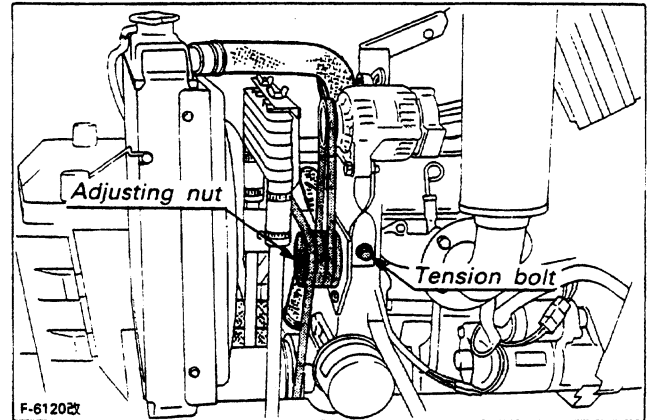

## 11.2 CLUTCH

Moderate clutch free travel ranges from 20 to 30 mm (0.8 to 1.2 in.).

If the clutch becomes difficult to disengage or free pedal travel decreases, adjust the length of the clutch rod after removing the pin. When the clutch is difficult to disengage, shorten the rod. To limit clutch free travel extend the clutch rod.

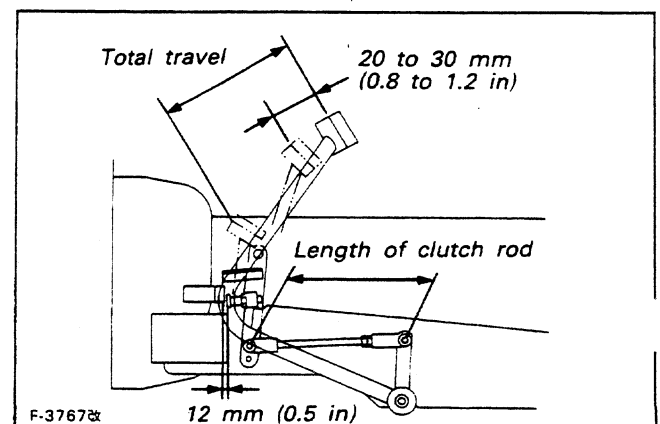

## 11.3 BRAKE

If brake pedal free travel becomes too great or travel varies between the right and left pedals, loosen the lock nut and adjust the length of the brake rod. Moderate right and left pedal free travel ranges from 20 to 30 mm (0.8 to 1.2 in.). After adjustment, interlock the right and left brake pedals and tighten the lock nut securely.

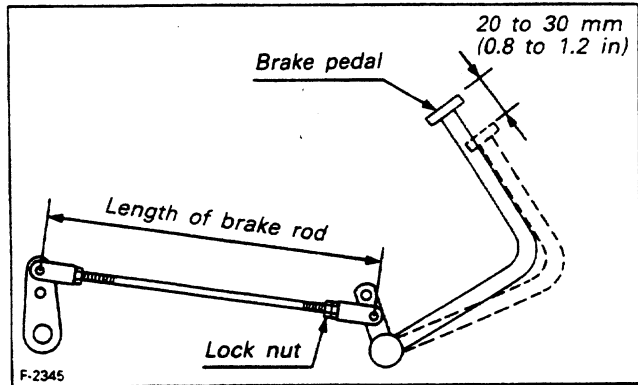

## 11.4 STEERING WHEEL

Moderate steering wheel play is 5 to 30 mm (0.2 to 1.2 in.). If excessive, consult KUBOTA dealers.

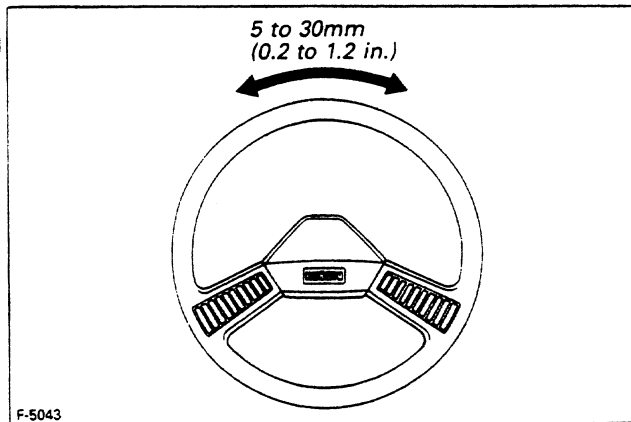

# 12. TROUBLESHOOTING

## 12.1 ENGINE TROUBLESHOOTING

### ■ When engine is difficult to start

Cause	Remedy
Fuel is thick and doesn't flow	<ul style="list-style-type: none"> <li>* Check the fuel tank and fuel filter.</li> <li>* Remove water, dirt and other impurities</li> <li>* As all fuel will be filtered by the filter, if there should be water or other foreign matter on the filter, replace the filter.</li> <li>* See your KUBOTA dealer.</li> <li>* Check if fuel type is correct for cold weather.</li> </ul>
Air or water mixed in fuel system	<ul style="list-style-type: none"> <li>* If air is in the fuel filter or injection lines, the fuel pump will not work properly. To attain proper fuel injection pressure, check carefully for loosened fuel lines, cap nut, etc.</li> <li>* Loosen air vent screws atop fuel filter and fuel injection pump to eliminate all the air in the fuel oil system.</li> </ul>
Thick carbon deposits on orifice of injection nozzle.	<ul style="list-style-type: none"> <li>* This is caused when water or dirt is mixed in the fuel. Clean the nozzle injection piece. Do not damage the orifice.</li> <li>* Check to see if nozzle is working properly or not. If not, install a new nozzle.</li> <li>* See your KUBOTA dealer.</li> </ul>
Valve clearance is incorrect	<ul style="list-style-type: none"> <li>* Adjust valve clearance.</li> <li>See your KUBOTA dealer.</li> </ul>
Leaking valves	<ul style="list-style-type: none"> <li>* Grind valves.</li> <li>* See your KUBOTA dealer.</li> </ul>
Fuel injection timing is incorrect	<ul style="list-style-type: none"> <li>* Adjust injection timing.</li> <li>See your KUBOTA dealer.</li> </ul>
Engine oil becomes thick in cold weather and engine cranks slow.	<ul style="list-style-type: none"> <li>* Change grade of oil according to the weather(temperature).</li> </ul>
Low compression	<ul style="list-style-type: none"> <li>* Bad valve or excessive wear of rings, pistons and liners cause insufficient compression. Replace with new parts.</li> </ul>
Battery is discharged and the engine will not crank.	<ul style="list-style-type: none"> <li>* Charge battery.</li> <li>* In winter, always remove battery from tractor, charge fully and keep indoors. Install in tractor at time of use.</li> </ul>

### ■ When output is insufficient

Cause	Remedy
Air cleaner is dirty Fuel filter is dirty	<ul style="list-style-type: none"> <li>* Clean the element every 100-200 hours of operation.</li> </ul>
Carbon around orifice of nozzle piece	<ul style="list-style-type: none"> <li>* Clean orifice and needle valve, being very careful not to damage the nozzle orifice.</li> <li>* Check nozzle.</li> <li>If defective, replace with new parts.</li> <li>* See your KUBOTA dealer.</li> </ul>
Compression is insufficient. Leaking valves	<ul style="list-style-type: none"> <li>* Bad valves and excessive wear of rings, pistons and liners cause insufficient compression. Replace with new parts.</li> <li>* Grind valves.</li> </ul>
Fuel is insufficient	<ul style="list-style-type: none"> <li>* Check fuel system.</li> </ul>
Overheating of moving parts	<ul style="list-style-type: none"> <li>* Check lube oil system.</li> <li>* Check to see if lube oil filter is working properly.</li> <li>* Filter screens or elements deposited with impurities would cause poor lubrication. Clean screens.</li> <li>* Check if bearing clearances are within factory specs.</li> <li>* Check engine timing.</li> </ul>
Valves out of adjustment	<ul style="list-style-type: none"> <li>* Adjust to proper valve clearance.</li> <li>See your KUBOTA dealer.</li> </ul>
Fuel injection pressure is incorrect	<ul style="list-style-type: none"> <li>* Adjust to proper pressure.</li> <li>See your KUBOTA dealer.</li> </ul>



### ■ When color of exhaust is dark

See your KUBOTA dealer.

### ■ When engine suddenly stops

Cause	Remedy
Leak of fuel	<ul style="list-style-type: none"> <li>* Check the fuel tank and refill if necessary.</li> <li>* Also check the fuel system for air or leaks</li> </ul>
Bad nozzle	<ul style="list-style-type: none"> <li>* If necessary, replace with a new nozzle.</li> </ul>
Moving parts are overheated due to shortage of lube oil or improper lubrication	<ul style="list-style-type: none"> <li>* Check amount of engine oil with dipstick.</li> <li>* Check lubricating oil system.</li> <li>* Check to see if element inside the lubricating oil filter (2) has become old and clogged. If necessary, replace with new element.</li> <li>* Check if the engine bearing clearances are within factory specs.</li> </ul>

### ■ When engine must be stopped immediately

Cause	Remedy
Speed suddenly decreases or increases	<ul style="list-style-type: none"> <li>* Check the adjustments and timing of injection and the fuel system.</li> </ul>
Unusual sound is heard suddenly.	<ul style="list-style-type: none"> <li>* Check all moving parts carefully.</li> </ul>
Color of exhaust suddenly turns dark	<ul style="list-style-type: none"> <li>* Check the fuel injection system, especially the fuel injection nozzle.</li> </ul>
Bearing parts are overheated	<ul style="list-style-type: none"> <li>* Check the lubricating system.</li> </ul>
Oil lamp lights up during operation	<ul style="list-style-type: none"> <li>* Check oil level.</li> <li>* Check lubricating system.</li> <li>* Check if the engine bearing clearances are within factory specs.</li> <li>* Check the function of the regulating valve inside the oil filter (2).</li> <li>* Check pressure switch</li> <li>* Check filter base gasket</li> </ul>

## 12.2 TRACTOR TROUBLESHOOTING

### ■ When 3 point hitch does not move

Cause	Remedy
Transmission oil filter cartridge plugged	<ul style="list-style-type: none"> <li>* Clean the strainer</li> </ul>
3 point hitch does not lower	<ul style="list-style-type: none"> <li>* Check the implement lowering speed control knob</li> </ul>

### ■ Tractor operation is not smooth

Cause	Remedy
Hydrostatic transmission fluid is insufficient.	<ul style="list-style-type: none"> <li>* Replenish oil.</li> </ul>
Filter is clogged	<ul style="list-style-type: none"> <li>* Replace the filter.</li> </ul>
Strainer is clogged	<ul style="list-style-type: none"> <li>* Clean the strainer.</li> </ul>

### ■ Tractor does not move while engine is running

Cause	Remedy
Range selector lever is at neutral.	<ul style="list-style-type: none"> <li>* Check the range selector lever.</li> </ul>
Parking brake is on.	<ul style="list-style-type: none"> <li>* Release the parking brake.</li> </ul>
Transmission fluid is insufficient.	<ul style="list-style-type: none"> <li>* Replenish oil.</li> </ul>

### ■ Tractor moves when speed control pedal is not depressed. (Engine is operated.)

Cause	Remedy
Hydrostatic lever linkage is not correctly adjusted.	<ul style="list-style-type: none"> <li>* Ask your dealer for hydrostatic lever linkage adjustment or pressure adjustment.</li> </ul>

## 12.3 BATTERY TROUBLESHOOTING

Condition of Battery	Cause	Remedy	Precaution
Starter does not function	Key is not "ON"	Turn key "ON"	Do not overuse the battery and charge before fully discharged. (Refrain from overdischarging)
	Battery over-used until light becomes dim	Charge for long period by ordinary charging method until specific gravity of 1.26 is reached.	
	Charging of battery neglected	Charge battery 1.26 at 20°C (68°F).	
	Defective Alternator rectifier.	Repair Alternator and replace defective rectifier. Charge battery well.	
	Dirty or corroded terminal contacts Bad brushes, armature or field	Wash terminal with hot water and tighten well. Replace	
Life of battery expired	Replace battery	Check Alternator rectifier.  Keep terminals clean, tighten well and grease to prevent corrosion.	
When starting, starter does not function, and lights become dim quickly.	Battery not charged well	Charge battery for long period by ordinary charging method.	Battery must be serviced properly before initial use.
Low electrolyte level.	Battery used with low electrolyte level.	Add distilled water and charge battery	Make routine checks of electrolyte
	Not serviced properly, over-charged. (Refrain from over-discharging.)	Charge for long period.	Do not overuse the battery and fully discharge.
	Defective Alternator rectifier. Defective terminal contacts causing sulphation of electrodes.	Check Alternator and rectifier and charge for long period by ordinary charging method.	Make routine checks of terminals, to make sure they are clean and tight.
Battery cannot be charged.	The current of the Alternator during operation is too high causing plates to drop, warp or short-circuit.	Decrease the charging current of Alternator. Exchange defective battery.	Check charging current of Alternator.
	Life of battery expired.	Exchange battery.	
Severe corrosion of terminals severe.	Lack of service.	Clean scale from terminals and tighten well.	Keep terminals clean and well tightened. Apply grease to prevent corrosion.
	Current of the Alternator during operation is too high.	Adjust charging current of Alternator.	Check charging current of Alternator.
Electrolyte decreases rapidly	Overheating due to overcharging.	Check charging output.	Secure battery to tractor so it will not move.
	Storage battery cracked or has small holes.	Replace battery	

# 13. LONG-TERM STORAGE



## CAUTION

- (1) When storing, remove the key from the key switch to avoid unauthorized persons from operating the tractor and getting injured.
- (2) To avoid the danger of exhaust-fume poisoning, do not operate the engine in a closed building without proper ventilation.

When the tractor will not be operated for two or three months or longer, clean the tractor and perform the following treatment before storage.

- (1) Repair any parts as needed.
- (2) Check nuts and bolts, tighten as necessary.
- (3) Apply grease or engine oil to the parts most likely to rust.
- (4) Inflate the tires to a little above the standard pressure levels.
- (5) Change the engine oil and run the engine for five minutes so that the oil circulates throughout the entire lubrication system.
- (6) Stop the engine by fully pulling the engine stop knob.
- (7) Drain the radiator. Flush and refill with new coolant.
- (8) Lock the clutch pedal with the provided wooden block. If the tractor is stored for a long period with the clutch left engaged, the clutch disc may rust, rendering it inoperative.

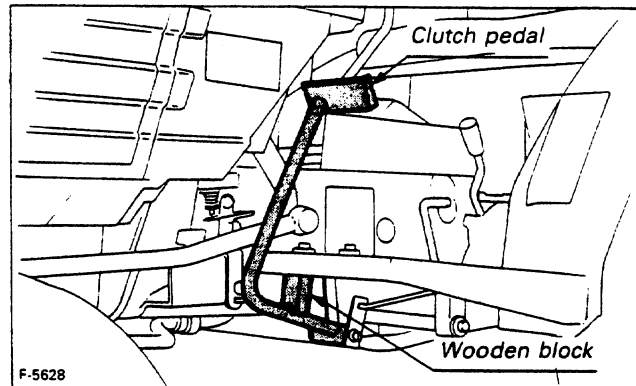

- (9) Lower the implement to the ground.
- (10) Remove the battery from the tractor, recharge it, adjust the electrolyte to the proper level, and store in a cool, dry place.
- (11) The battery runs down over time even while in storage. Recharge it once a month in hot seasons and once every two months in cold seasons.
- (12) Store the tractor where dry and sheltered from rain. Further cover the tractor with a tarpaulin.
- (13) When leaving the tractor outdoors, protect the muffler from the rain.

## IMPORTANT

- To clean the tractor stop the engine. If you must clean the tractor with the engine going, utmost care should be taken not to allow water to enter the air cleaner. Engine trouble may occur if water enters the engine.

# 14. OPTIONS (consult your KUBOTA Dealer)

## ■ SMV (Slow Moving Vehicle) Emblem

Recommended to forewarn overtaking traffic of tractor's presence.

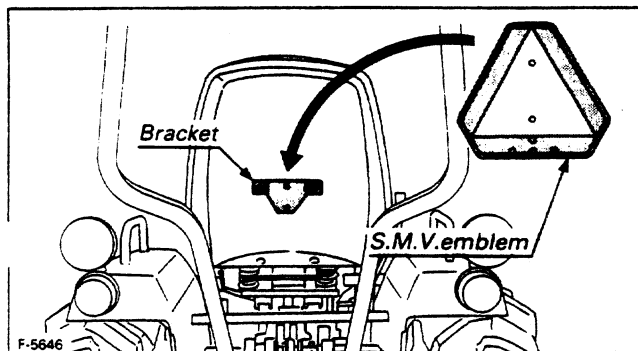

## ■ Drawbar

See page 22.

# 15. LUBRICANT SPECIFICATIONS

## ■ Engine Oil

Oil used in the engine should have an American Petroleum Institute (API) / SAE Classification of service CC or CD. The chart below shows the correct oil to be used at various temperature conditions:

### ENGINE OIL VISCOSITY CHART

Below 0°C (32°F)	SAE 10W or 10W-30
0 to 25°C (32 to 77°F)	SAE 20 or 10W-30
Above 25°C (77°F)	SAE 30 or 10W-30

## ■ Others

Power steering	Multi-grade transmission fluid (Same as transmission oil)
Front Wheel Bearings [2WD]	SAE lithum based grease
Chassis grease fittings	Multipurpose type grease
Front Wheel Drive Unit [4WD]	SAE 80 or 90 gear oil

## ■ Transmission Oil

The oil used to lubricate the transmission is also used as hydraulic fluid. To insure proper operation of the hydraulic system and complete lubrication of the transmission, it is important that a multi-grade transmission fluid be used in this system. We recommend the use of KUBOTA UDT fluid for optimum protection and performance.

Also the following are recommended oils, by brand name, that may be used in the transmission hydraulic system. Do not mix different brands together.

Maker	Brand Name
Atlantic Richfield (ARCO)	Arco Tractor Fluid
Chevron	Tractor Hydraulic Fluid
Exxon	Torque Fluid 56
Penzoil	Hydra-Trans and Wet Br.
Phillips	H.T.Fluid
Shell	Donax TD,TT,TM
Texaco	T.D.H.Oil
Union	Hydraulic / Tractor Fluid
Gulf	Universal Fluid 425,350
Mobil	Mobil Fluid 423,350

## KUBOTA LUBRICANTS

THE BEST CHOICE SINCE BUYING YOUR KUBOTA

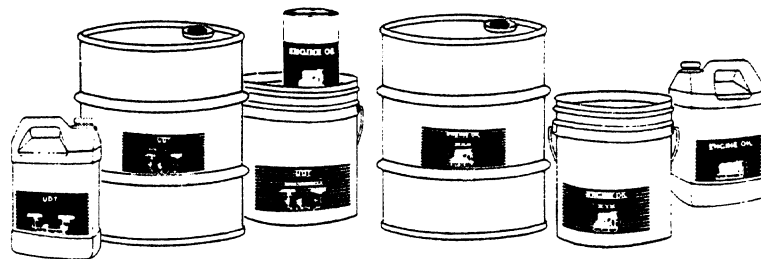

When you think of Kubota diesel tractors, you think of quality, performance and service. Now you can also think of Kubota lubricants.

Now, Kubota offers a lubricant line to use with all the Kubota tractors from 10 to 85 PTO horsepower. The Kubota lubricant line consists of a 15W-40 or 10W-30 engine oil and a universal transdraulic fluid called "UDT." A variety of sizes are available to meet your small and larger needs, in 1 quart, 2 gallon, 5 gallon and 55 gallon containers.

Next time you need to pour it on, pour it in with Kubota lubricants.

Kubota lubricants, tractor tough quality.

## KUBOTA

Nothing like it on earth.™

# 16. WIRING DIAGRAM

[A TYPE]

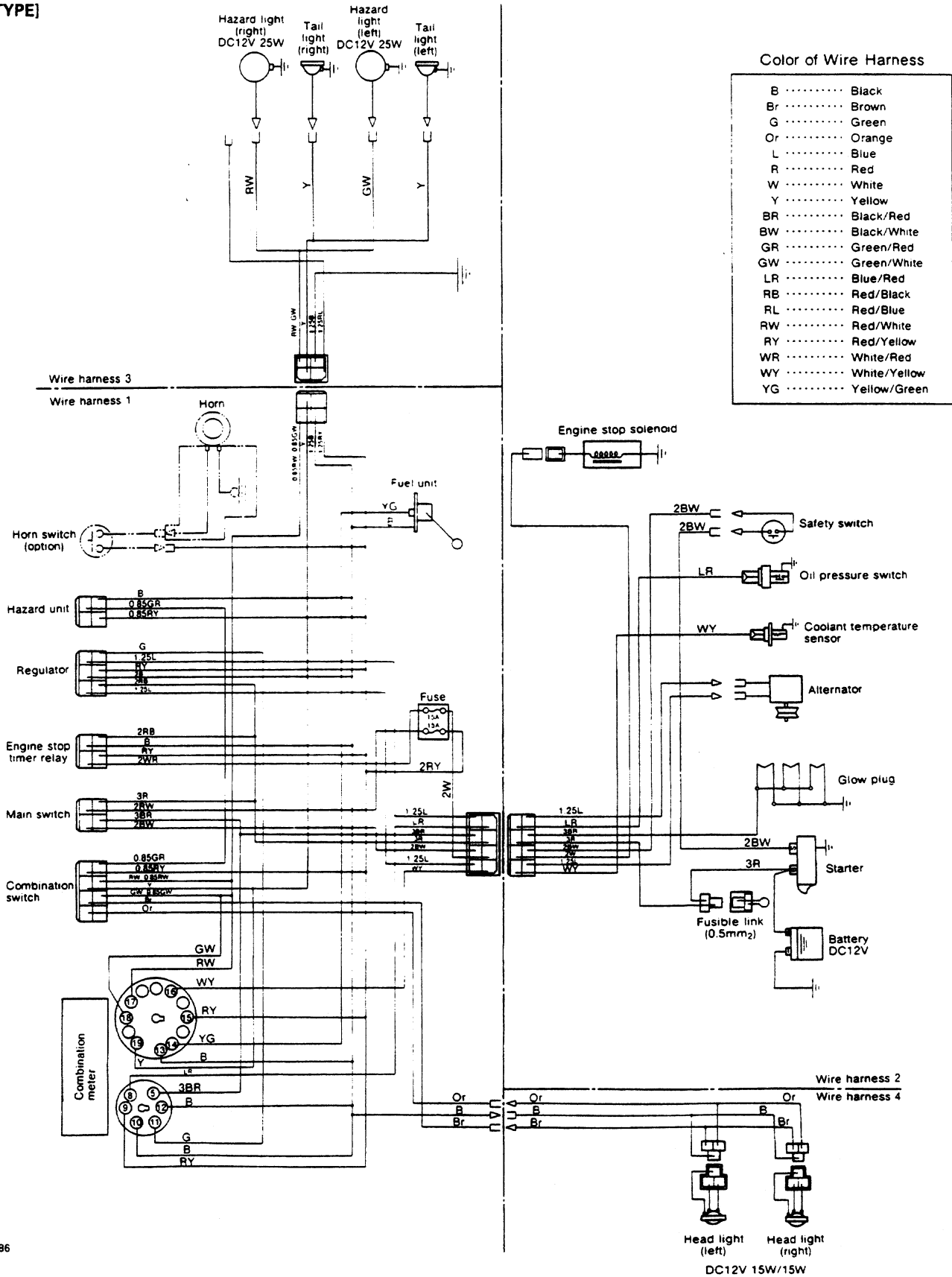

[ B TYPE ]

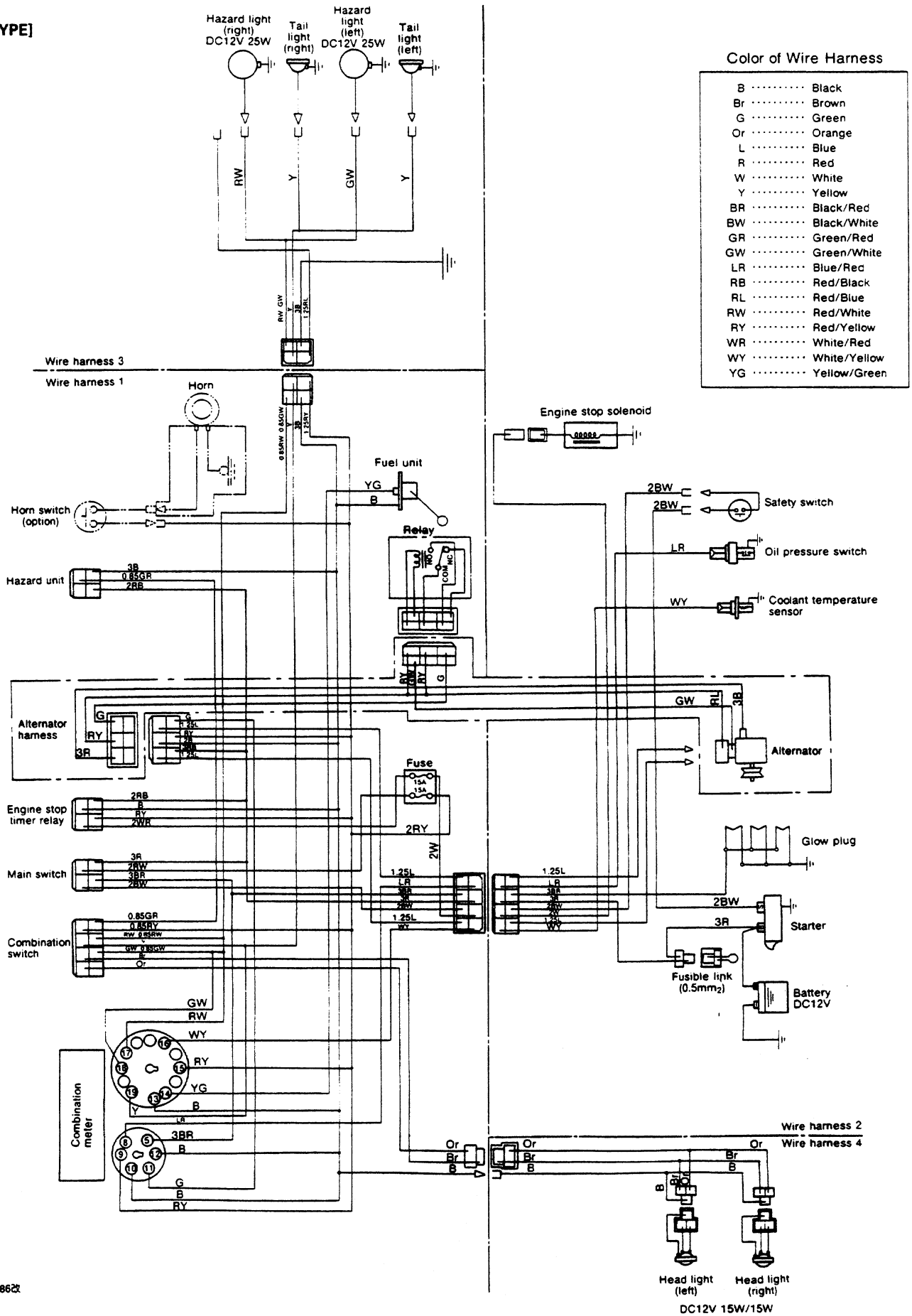

# INDEX

## A

Air cleaner .....	39
Anti-freeze .....	39

## B

Ballast .....	25
Battery .....	40
Battery charge light .....	14,29
Battery troubleshooting .....	46
Bi-Speed turn lever .....	17
Bleeding, fuel line .....	32
Brake adjustment .....	43
Brake pedals .....	18

## C

Charging, dry type battery .....	41
Clutch chains, adjustment .....	22
Clutch adjustment .....	42
Clutch release hub .....	37
Controls .....	15

## D

Daily check .....	30
Differential lock pedal .....	18
Drawbar .....	22

## E

Easy checker .....	14
Engine oil .....	33
Engine oil filter cartridge change .....	34
Engine oil pressure light .....	14,29
Engine stop knob .....	15
Engine troubleshooting .....	44

## F

Fan drive belt .....	42
Front axle differential case oil, changing .....	35
Front axle gear case oil, changing .....	36
Front wheel drive lever .....	17
Fuel .....	32
Fuel filter bowl, cleaning .....	33
Fuel line, checking .....	32
Fuses .....	14

## G

Glow plug indicator .....	14
---------------------------	----

## H

Hazard light switch .....	13
High-low gear shift lever .....	16
Horn button (if equipped) .....	14
Hour meter .....	14
Hydraulic block type outlet .....	21

## I

Implement limitations .....	10,11
Instrument panel .....	13

## J

Jump starting .....	4
---------------------	---

## K

Key switch .....	13
------------------	----

## L

Lifting rod, adjustment .....	22
Light switch .....	13
Long-term storage .....	47
Lubricants .....	30
Lubricant specifications .....	48

## M

Maintenance check list .....	31
------------------------------	----

## O

Oiling and greasing points before starting .....	36,37
Operating the engine .....	27
Operating the PTO .....	3
Operating the tractor .....	27

## P

Parking brake lever .....	18
PTO speed gear shift lever .....	17
Position control .....	19
Position control lever .....	19
Power steering .....	20

## R

Radiator .....	38
----------------	----

## S

Safety .....	1 to 4
Safety labels .....	5
Seat, adjustable sliding .....	18
Serial number .....	6
Servicing of tractor .....	6
Specifications .....	7
Speed control pedal .....	16
Speed set device .....	16
Speed, traveling .....	9
Starting engine .....	27
Steering wheel .....	43
Stopping engine .....	27
Switches .....	13

## T

Three-point hitch .....	22
Throttle lever .....	15
Tires .....	25
Toe-in .....	26
Tractor troubleshooting .....	45
Transmission fluid .....	34
Transmission strainer .....	35
Traveling speeds .....	9
Treads .....	24

## U

Using 3-point hitch .....	3
---------------------------	---

## W

Wheel hub .....	25
Wiring diagram .....	49









1  
2  
3  
4  
5  
6  
7  
8  
9  
10  
11  
12  
13  
14  
15  
16  
17  
18  
19  
20  
21  
22  
23  
24  
25  
26  
27  
28  
29  
30  
31  
32  
33  
34  
35  
36  
37  
38  
39  
40  
41  
42  
43  
44  
45  
46  
47  
48  
49  
50  
51  
52  
53  
54  
55  
56  
57  
58  
59  
60  
61  
62  
63  
64  
65  
66  
67  
68  
69  
70  
71  
72  
73  
74  
75  
76  
77  
78  
79  
80  
81  
82  
83  
84  
85  
86  
87  
88  
89  
90  
91  
92  
93  
94  
95  
96  
97  
98  
99  
100

101  
102  
103  
104  
105  
106  
107  
108  
109  
110  
111  
112  
113  
114  
115  
116  
117  
118  
119  
120  
121  
122  
123  
124  
125  
126  
127  
128  
129  
130  
131  
132  
133  
134  
135  
136  
137  
138  
139  
140  
141  
142  
143  
144  
145  
146  
147  
148  
149  
150

---

# Kubota®

## KUBOTA TRACTOR CORPORATION

**CORPORATE OFFICE: 3401 DEL AMO BOULEVARD, TORRANCE, CA 90503**  
WESTERN DIVISION: 6665 Hardaway Road, Stockton, CA 95215 • (209) 931-5051  
CENTRAL DIVISION: 14855 F.A.A. Blvd., Fort Worth, TX 76155 • (817) 571-0900  
NORTHERN DIVISION: 2626 Port Road, Columbus, OH 43217 • (614) 492-1100  
SOUTHEAST DIVISION: 1025 North Brook Parkway, Suwanee, GA 30174 • (770) 995-8855

---



PRINTED IN U.S.A.

June 2002

Code No. 66417-62914

