

WSM

WORKSHOP MANUAL
TRACTOR

B2050, B2350, B2650, B3150

Kubota

TO THE READER

This Workshop Manual tells the servicing personnel about the mechanism, servicing and maintenance of the B2050, B2350, B2650 and B3150. It contains 4 parts: "**Information**", "**General**", "**Mechanism**" and "**Servicing**".

■ **Information**

This section primarily contains information below.

- Safety First
- Safety Decal
- Specifications
- Dimensions

■ **General**

This section primarily contains information below.

- Engine Identification
- Model Identification
- General Precautions
- Maintenance Check List
- Check and Maintenance
- Special Tools

■ **Mechanism**

This section contains information on the structure and the function of the unit. Before you continue with the subsequent sections, make sure that you read this section.

Refer to the latest version of Workshop Manual (Code No. 9Y021-01870 / 9Y021-18200) for the diesel engine / tractor mechanism that this workshop manual does not include.

■ **Servicing**

This section primarily contains information below.

- Troubleshooting
- Servicing Specifications
- Tightening Torques
- Checking, Disassembling and Servicing

All illustrations, photographs and specifications contained in this manual are of the newest information available at the time of publication.

KUBOTA reserves the right to change all information at any time without notice.

Since this manual includes many models, information or illustrations and photographs can show more than one model.

I INFORMATION

INFORMATION

CONTENTS

1. SAFETY FIRST	I-1
2. SAFETY DECALS	I-4
3. SPECIFICATIONS.....	I-7
4. TRAVELING SPEEDS.....	I-11
5. DIMENSIONS.....	I-13

1. SAFETY FIRST

SAFETY FIRST

- This symbol, the industry's "Safety Alert Symbol", is used throughout this manual and on labels on the machine itself to warn of the possibility of personal injury. Read these instructions carefully.
- It is essential that you read the instructions and safety regulations before you try to repair or use this unit.

DANGER

- Indicates an imminently hazardous situation which, if not avoided, will result in death or serious injury.

WARNING

- Indicates a potentially hazardous situation which, if not avoided, could result in death or serious injury.

CAUTION

- Indicates a potentially hazardous situation which, if not avoided, may result in minor or moderate injury.

■ IMPORTANT

- Indicates that equipment or property damage could result if instructions are not followed.

■ NOTE

- Gives helpful information.

WSM000001INI0001US1

BEFORE YOU START SERVICE

- Read all instructions and safety instructions in this manual and on your machine safety decals.
- Clean the work area and machine.
- Park the machine on a stable and level ground, and set the parking brake.
- Lower the implement to the ground.
- Stop the engine, then remove the key.
- Disconnect the battery negative cable.
- Hang a "DO NOT OPERATE" tag in the operator station.

WSM000001INI0010US0

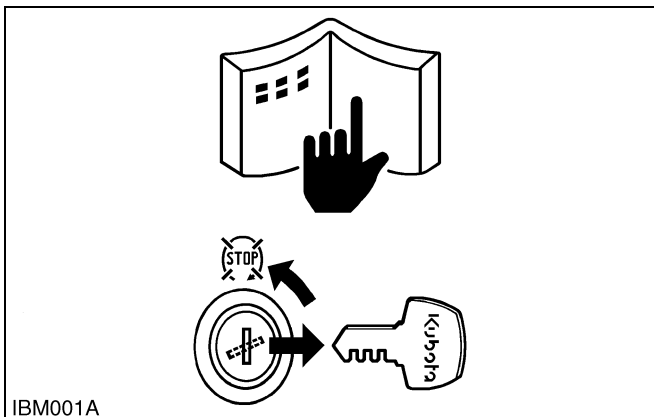

START SAFELY

- Do not do the procedures below when you start the engine.
 - short across starter terminals
 - bypass the safety start switch
- Do not alter or remove any part of machine safety system.
- Before you start the engine, make sure that all shift levers are in neutral positions or in disengaged positions.
- Do not start the engine when you stay on the ground. Start the engine only from operator's seat.

WSM000001INI0015US0

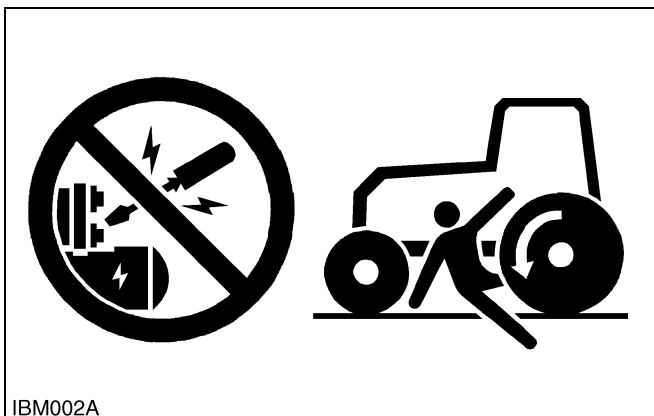

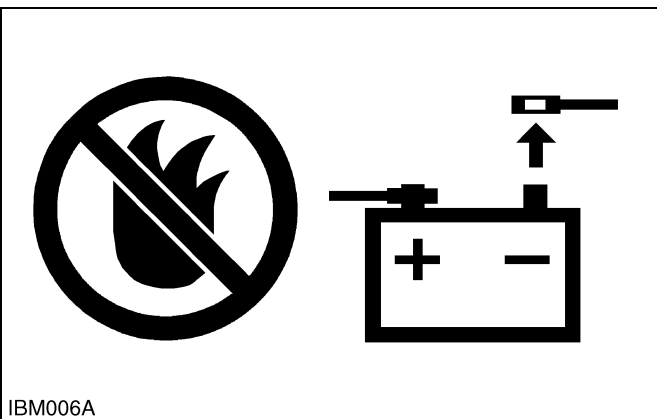
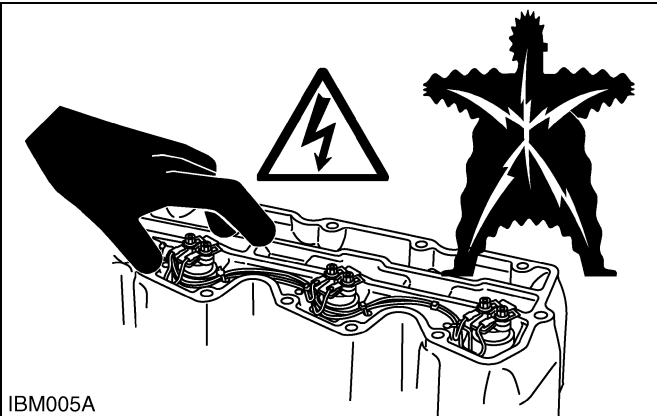
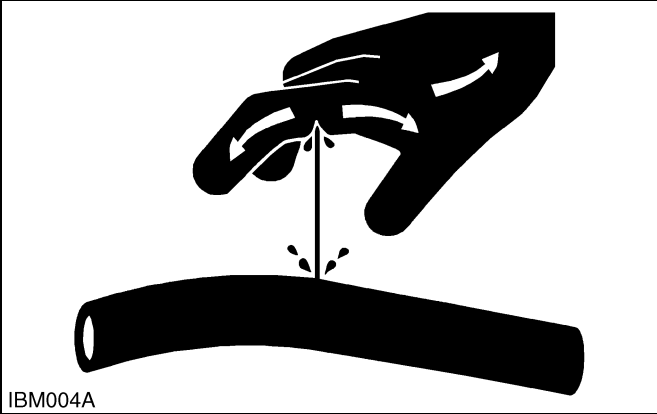
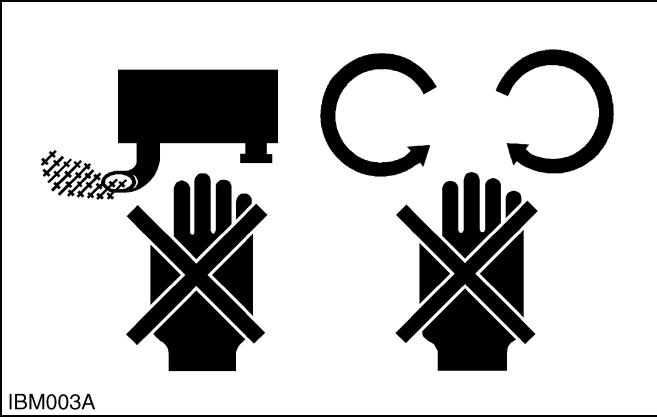

OPERATE SAFELY

- Do not use the machine after you consume alcohol or medication or when you are tired.
- Put on applicable clothing and safety equipment.
- Use applicable tools only. Do not use alternative tools or parts.
- When 2 or more persons do servicing, make sure that you do it safely.
- Do not operate below the machine that only a jack holds. Always use a safety stand to hold the machine.
- Do not touch the hot parts or parts that turn when the engine operates.
- Do not remove the radiator cap when the engine operates, or immediately after it stops. If not, hot water can spout out from the radiator. Only remove the radiator cap when it is at a sufficiently low temperature to touch with bare hands. Slowly loosen the cap to release the pressure before you remove it fully.
- Released fluid (fuel or hydraulic oil) under pressure can cause damage to the skin and cause serious injury. Release the pressure before you disconnect hydraulic or fuel lines. Tighten all connections before you apply the pressure.
- Do not open a fuel system under high pressure. The fluid under high pressure that stays in fuel lines can cause serious injury. Do not disconnect or repair the fuel lines, sensors, or any other components between the fuel pump and injectors on engines with a common rail fuel system under high pressure.
- Put on an applicable ear protective device (earmuffs or earplugs) to prevent injury against loud noises.
- Be careful about electric shock. The engine generates a high voltage of more than DC100 V in the ECU and is applied to the injector.

WSM000001INI0012US0

PREVENT A FIRE

- Fuel is very flammable and explosive under some conditions. Do not smoke or let flames or sparks in your work area.
- To prevent sparks from an accidental short circuit, always disconnect the battery negative cable first and connect it last.
- The battery gas can cause an explosion. Keep the sparks and open flame away from the top of battery, especially when you charge the battery.
- Make sure that you do not spill fuel on the engine.

WSM000001INI0005US0

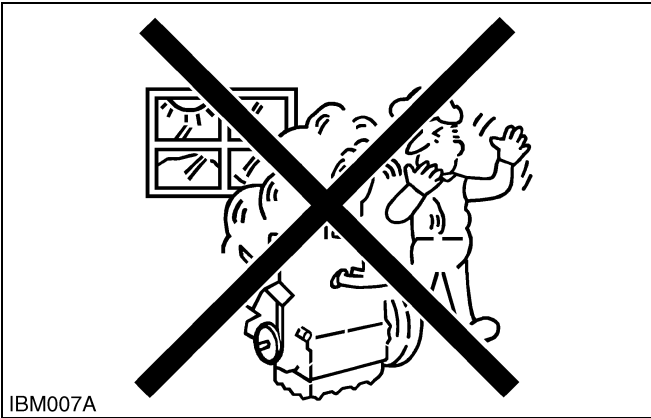

KEEP A GOOD AIRFLOW IN THE WORK AREA

- If the engine is in operation, make sure that the area has good airflow. Do not operate the engine in a closed area. The exhaust gas contains poisonous carbon monoxide.

WSM000001INI0006US0

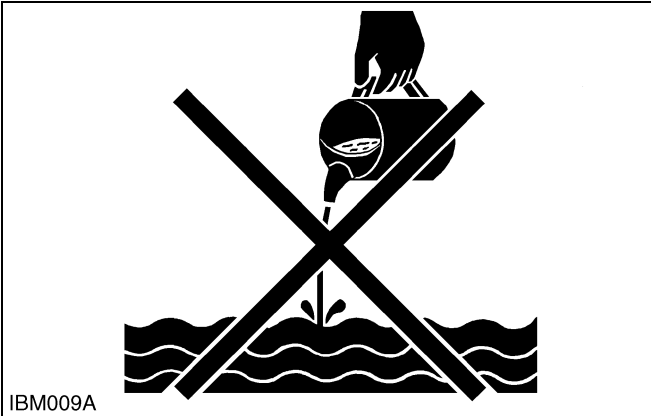

DISCARD FLUIDS CORRECTLY

- Do not discard fluids on the ground, down the drain, into a stream, pond, or lake. Obey related environmental protection regulations when you discard oil, fuel, coolant, electrolyte and other dangerous waste.

WSM000001INI0007US0

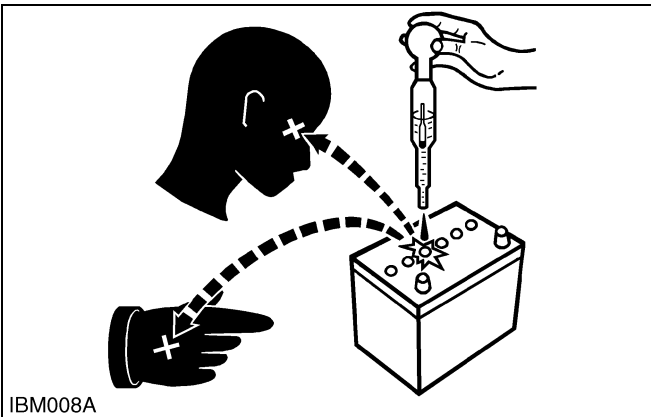

PREVENT ACID BURNS

- Keep electrolyte away from your eyes, hands and clothing. Sulfuric acid in battery electrolyte is poisonous and it can burn your skin and clothing and cause blindness. If you spill electrolyte on yourself, clean yourself with water, and get medical aid immediately.

WSM000001INI0008US0

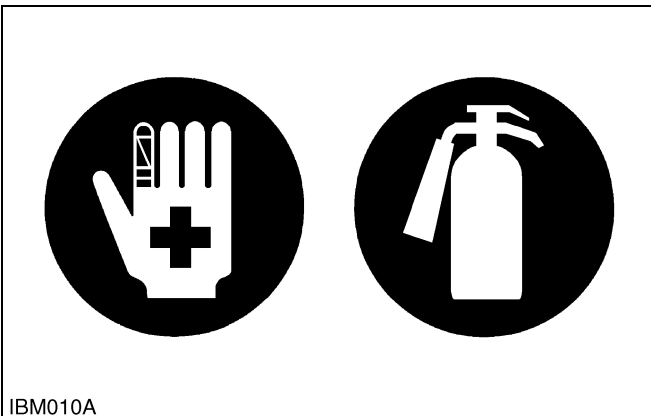

PREPARE FOR EMERGENCIES

- Keep a first aid kit and fire extinguisher ready at all times.
- Keep the emergency contact telephone numbers near your telephone at all times.

WSM000001INI0009US0

2. SAFETY DECALS

The following safety decals (pictorial safety labels) are installed on the machine. If a decal becomes damaged, illegible or is not on the machine, replace it. The decal part number is listed in the parts list.

WSM000001INI0014US0

(1) Part No. 6C300-3012-2



(2) Part No. 6C090-4958-2
Do not get your hands close to engine fan and fan belt.



(3) Part No. 6C430-4959-1
Do not touch hot surface like muffler, etc.

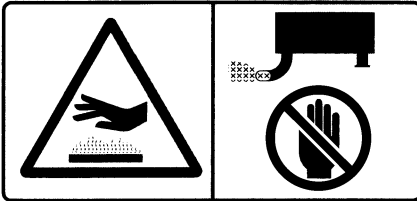

(4) Part No. 3A481-9853-1

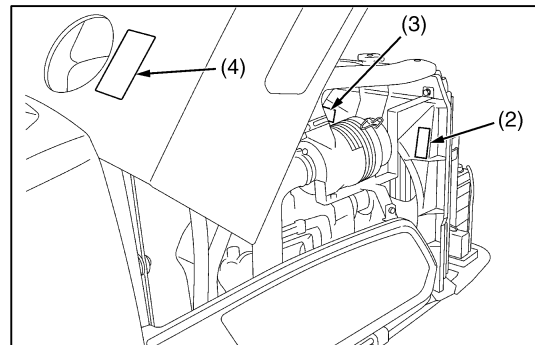
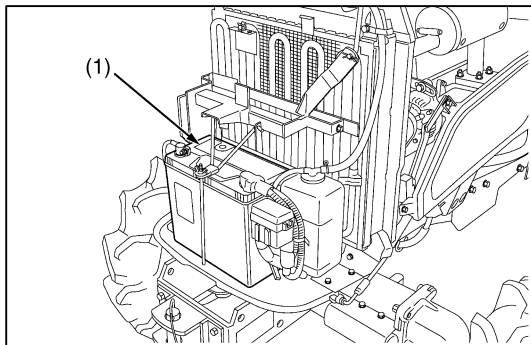
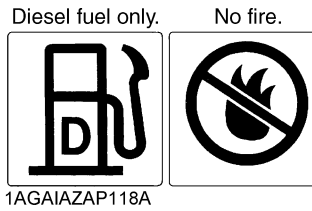

9Y1210982ICI001US

9Y1210982INI0001US0

- (1) Part No. 6C090-4958-2
Do not get your hands close to engine fan and fan belt.



1AGAIAZAP110A

- (2) Part No. K3512-4718-1
Start engine from operator's seat only.

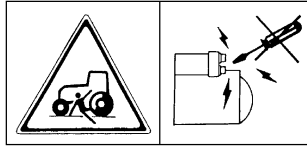

1BDABANAP083B

- (3) Part No. TD179-3491-1
Carefully read operator's manual before handling the machine. Observe instructions and safety rules when operating.

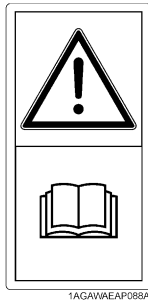

1AGAWAEAP088A

- (4) Part No. 6C392-9848-1
Always lock ROPS in upright position unless it has to be folded down to allow operation underneath trees or bushes. When ROPS is locked in upright position, seat belt should be used.



1AGAEDBAP0430

- (5) Part No. 3P903-4902-1
Seat belt should be used.



1AGAIFYAP086A

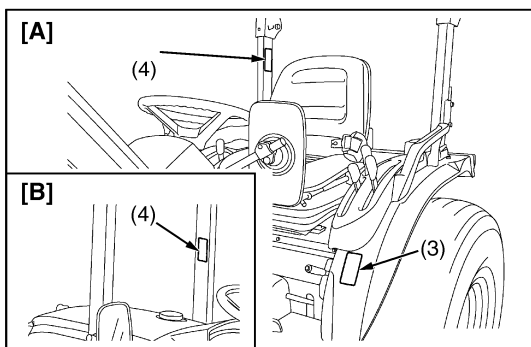
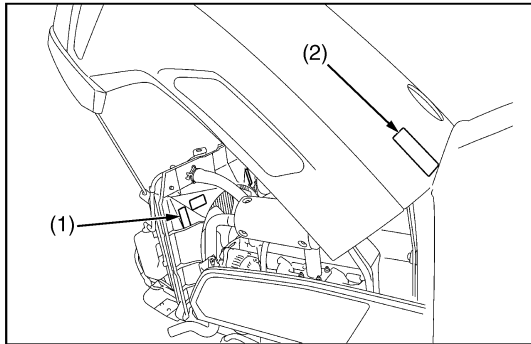

[A] Rear Mount Type ROPS
[B] Mid Mount Type ROPS

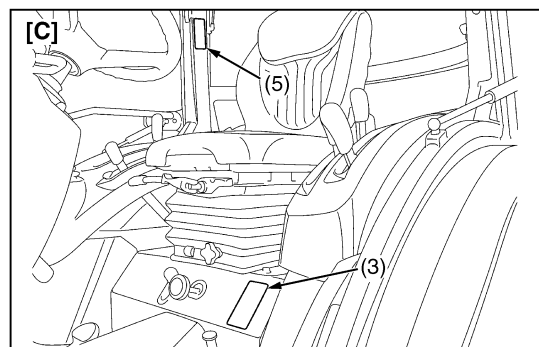

[C] CAB Type

(1) Part No. 6C482-4711-1

- Stay clear of the PTO shaft.
- Keep PTO shield in place at all times.
- Do not operate the PTO at speeds faster than the speed recommended by the implement manufacturer.
- For trailing PTO-driven implements, set drawbar at towing position.
(see operator's manual)

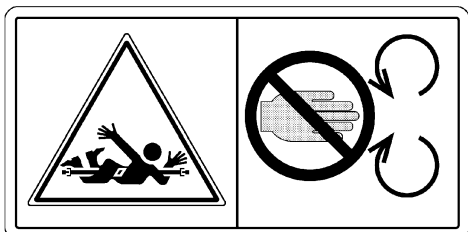

1AGAEEGAP089A

[B3150 ROPS Type only]

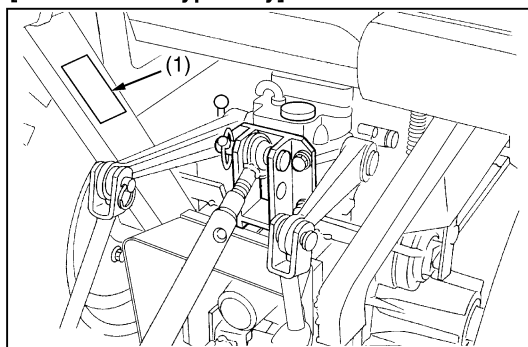

[B2050/B2350/B2650 ROPS Type only]

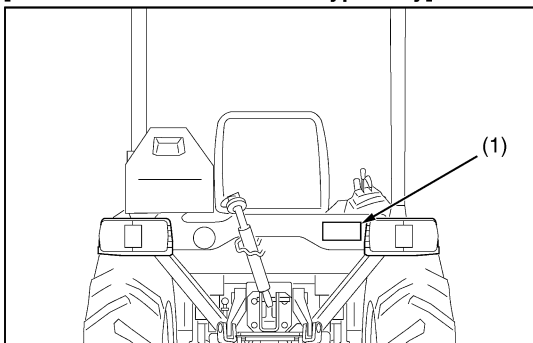

[B2050/B2350/B2650 CAB Type only]

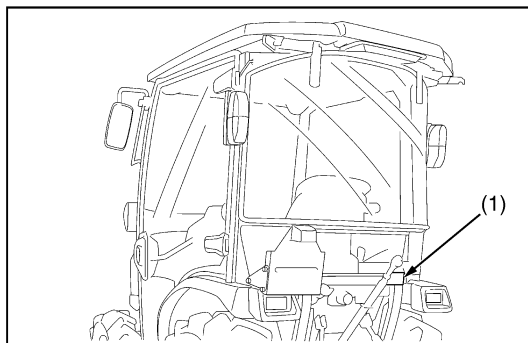

9Y1210982ICI003US

9Y1210982INI0003US0

CARE OF PICTORIAL SAFETY LABELS

1. Keep pictorial safety labels clean and free from obstructing material.
2. Clean pictorial safety labels with soap and water, dry with a soft cloth.
3. Replace damaged or missing pictorial safety labels with new labels.
4. If a component with pictorial safety label(s) affixed is replaced with new part, make sure new label(s) is (are) attached in the same location(s) as the replace component.
5. Mount new pictorial safety labels by applying on a clean dry surface and pressing any bubbles to outside edge.

9Y1210982INI0004US0

3. SPECIFICATIONS

[ROPS and CAB HST Type]

Model		B2350	B2650	B3150
PTO power *1		12.5 kW (17.0 PS)	14.6 kW (19.9 PS)	17.4 kW (23.6 PS)
Engine	Maker	KUBOTA		
	Model	D1105	D1305	V1505
	Type	Indirect Injection. Vertical, water-cooled, 4 cycle diesel		
	Number of cylinders	3		4
	Bore and stroke	78 × 78.4 mm (3.07 × 3.08 in.)	78 × 88 mm (3.07 × 3.46 in.)	78 × 78.4 mm (3.07 × 3.08 in.)
	Total displacement	1123 cm ³ (68.53 cu.in.)	1261 cm ³ (76.95 cu.in.)	1498 cm ³ (91.41 cu.in.)
	Engine gross power *1	15.9 kW (21.6 PS)	18.5 kW (25.2 PS)	21.8 kW (29.6 PS)
	Rated revolution	2500 min ⁻¹ (rpm)		
	Maximum torque	71.3 N·m (7.27 kgf·m, 52.6 lbf·ft)	84.0 N·m (8.57 kgf·m, 62.0 lbf·ft)	97.9 N·m (9.98 kgf·m, 72.2 lbf·ft)
	Battery	12 V, RC : 80 min, CCA (SAE) : 430 A, CCA (EN) : 360 A		
	Fuel	Diesel fuel No.2 [above -10 °C (14 °F)], Diesel fuel No.1 [below -10 °C (14 °F)]		
Capacities	Fuel tank	27 L (7.1 U.S.gals, 5.9 Imp.gals)		
	Engine crankcase (with filter)	3.1 L (3.3 U.S.qts, 2.7 Imp.qts)	4.0 L (4.2 U.S.qts, 3.5 Imp.qts)	
	Engine coolant	4.6 L (4.9 U.S.qts, 4.0 Imp.qts)		
	Transmission case	17.0 L (4.49 U.S.gals, 3.74 Imp.gals)		
Dimensions	Overall length (with 3P)	ROPS	2730 mm (107.5 in.)	2937 mm (115.6 in.)
		CAB	2887 mm (113.7 in.)	3007 mm (118.4 in.)
	Overall width (min. tread)		1249 mm (49.17 in.)	1365 mm (53.74 in.)
	Overall height	Rear ROPS	2353 mm (92.64 in.)	2327 mm (91.61 in.)
		CAB	2112 mm (83.15 in.)	2140 mm (84.25 in.)
	Wheel base	ROPS	1500 mm (59.06 in.)	1666 mm (65.59 in.)
		CAB	1560 mm (61.42 in.)	1666 mm (65.59 in.)
Minimum ground clearance		290 mm (11.4 in.)	318 mm (12.5 in.)	
Tread	Front	830 mm (32.7 in.)	936 mm (36.8 in.)	
	Rear	1006 mm (39.61 in.)	1050 mm (41.34 in.)	
Weight	Rear ROPS	839 to 865 kg (1850 to 1900 lbs)		908 to 934 kg (2010 to 2050 lbs)
	CAB	1082 to 1108 kg (2386 to 2442 lbs)		1124 to 1150 kg (2478 to 2535 lbs)
Clutch		N/A		
Traveling system	Tires	Front	6.00-12	180/85D12
		Rear	9.5-18	12.4-16
	Steering	hydraulic power steering		
	Transmission	Main-hydrostatic transmission, 3 range gear shift		
	Brake	Wet disk type		
Minimum turning radius (with brake)	2.1 m (6.9 feet)			
Hydraulic unit	Hydraulic control system		Position Control	
	Pump capacity		3P : 18.9 L/min (4.99 gals/min), Power steering : 14.2 L/min (3.75 gals/min)	
	3-point hitch		SAE Category 1	
	Max. lift force	At lift points	970 kg (2138 lbs)	
		600 mm behind lift point	760 kg (1676 lbs)	
	Remote hydraulic control		2 Standard	
Remote control valve coupler		Hose connection type outlet		
PTO	Rear-PTO		SAE 1-3/8, 6 splines	
		PTO / Engine speed	540 min ⁻¹ (rpm) / 2400 min ⁻¹ (rpm)	
	Mid-PTO		USA No.5 (KUBOTA 10-tooth) involute spline	
		PTO / Engine speed	2500 min ⁻¹ (rpm) / 2500 min ⁻¹ (rpm)	

Model		B2350	B2650	B3150	
The level of protection against hazardous substances *2		ROPS	N/A		
		CAB	Category 1		
Noise at the operator's ear *3		ROPS	84.5 dB (A)	85.8 dB (A)	85.0 dB (A)
		CAB/door closed	81.2 dB (A)	85.0 dB (A)	83.0 dB (A)
		CAB/door opened	82.8 dB (A)	85.8 dB (A)	82.0 dB (A)
Noise of the tractor in motion *4		ROPS	80 dB (A)	80 dB (A)	80 dB (A)
		CAB	80 dB (A)	80 dB (A)	82 dB (A)
Value of the vibration level *5	GRAMMER MSG 83/511	Light driver	1.13 m/s ²		
		Heavy driver	1.00 m/s ²		
	GRAMMER MSG 93/511	Light driver	1.21 m/s ²		
		Heavy driver	1.05 m/s ²		
	SEARS 807	Light driver	1.06 m/s ²		
		Heavy driver	1.24 m/s ²		
	SEARS 830	Light driver	1.00 m/s ²		
		Heavy driver	1.14 m/s ²		
	COBO SC74/M91 *6	Light driver	1.13 m/s ²		
		Heavy driver	0.75 m/s ²		

The company reserves the right to change the specifications without notice.

■ **NOTE**

- *1 : Manufacturer's estimate
- *2 : According to EN 15695-1:2009
- *3 : Measured according to Directive 2009/76/EC ANNEX II
- *4 : Measured according to Directive 2009/63/EC
- *5 : Measured according to Directive 78/764/EEC
- *6 : Except CAB model.

ROPS Manual Transmission Type

Model		B2050	B2350	B2650
PTO power *1		11.9 kW (16.2 PS)	13.0 kW (17.7 PS)	15.1 kW (20.5 PS)
Engine	Maker	KUBOTA		
	Model	D1105		D1305
	Type	Indirect Injection. Vertical, water-cooled, 4-cycle diesel		
	Number of cylinders	3		
	Bore and stroke	78 × 78.4 mm (3.07 × 3.08 in.)		78 × 88 mm (3.07 × 3.46 in.)
	Total displacement	1123 cm ³ (68.53 cu.in.)		1261 cm ³ (76.95 cu.in.)
	Engine gross power *1	14.6 kW (19.8 PS)	15.9 kW (21.6 PS)	18.5 kW (25.2 PS)
	Rated revolution	2500 min ⁻¹ (rpm)		
	Maximum torque	68.1 N·m (6.4 kgf·m, 50.2 lbf·ft)	71.3 N·m (7.27 kgf·m, 52.6 lbf·ft)	84.0 N·m (8.57 kgf·m, 62.0 lbf·ft)
	Battery	12 V, RC : 80 min, CCA (SAE) : 430 A, CCA (EN) : 360 A		
	Fuel	Diesel fuel No.2 [above -10 °C (14 °F)], Diesel fuel No.1 [below -10 °C (14 °F)]		
Capacities	Fuel tank	27 L (7.1 U.S.gals, 5.9 Imp.gals)		
	Engine crankcase (with filter)	3.1 L (3.3 U.S.qts, 2.7 Imp.qts)		4.0 L (4.2 U.S.qts, 3.5 Imp.qts)
	Engine coolant	4.6 L (4.9 U.S.qts, 4.0 Imp.qts)		
	Transmission case	16.5 L (4.36 U.S.gals, 3.63 Imp.gals)		
Dimensions	Overall length (with 3P)	2730 mm (107.5 in.)		
	Overall width (min. tread)	1249 mm (49.17 in.)		
	Overall height	Rear ROPS	2353 mm (92.64 in.)	
		Center ROPS	2069 mm (81.46 in.)	-
	Wheel base	1500 mm (59.06 in.)		
	Minimum ground clearance	290 mm (11.4 in.)		
	Tread	Front	830 mm (32.7 in.)	
Rear		1006 mm (39.61 in.)		
Weight	Rear ROPS	819 to 845 kg (1810 to 1860 lbs)		
	Center ROPS	839 to 865 kg (1850 to 1900 lbs)	-	839 to 865 kg (1850 to 1900 lbs)
Clutch		Dry single plate		
Traveling system	Tires	Front	6.00-12	
		Rear	9.5-18	
	Steering	hydraulic power steering		
	Transmission	Gear shift, 9 foreword and 9 reverse		
	Brake	Wet disk type		
Minimum turning radius (with brake)	2.1 m (6.9 feet)			
Hydraulic unit	Hydraulic control system		Position Control	
	Pump capacity		3P : 18.9 L/min (4.99 gals/min), Power steering : 14.2 L/min (3.75 gals/min)	
	3-point hitch		SAE Category 1	
	Max. lift force	At lift points	970 kg (2138 lbs)	
		600 mm behind lift point	760 kg (1676 lbs)	
	Remote hydraulic control		1 Standard	
Remote control valve coupler		Block type outlet		
PTO	Rear-PTO		SAE 1-3/8, 6 splines	
		PTO / Engine speed	540 min ⁻¹ (rpm) / 2400 min ⁻¹ (rpm)	
	Mid-PTO		USA No.5 (KUBOTA 10-tooth) involute spline	
		PTO / Engine speed	2500 min ⁻¹ (rpm) / 2500 min ⁻¹ (rpm)	
The level of protection against hazardous substances *2		N/A		
Noise at the operator's ear *3		83.5 dB (A)	83.5 dB (A)	85.4 dB (A)
Noise of the tractor in motion *4		77 dB (A)	77 dB (A)	79 dB (A)

Model			B2050	B2350	B2650
Value of the vibration level *5	GRAMMER MSG 83/511	Light driver		1.13 m/s ²	
		Heavy driver		1.00 m/s ²	
	GRAMMER MSG 93/511	Light driver		1.21 m/s ²	
		Heavy driver		1.05 m/s ²	
	SEARS 807	Light driver		1.06 m/s ²	
		Heavy driver		1.24 m/s ²	
	SEARS 830	Light driver		1.00 m/s ²	
		Heavy driver		1.14 m/s ²	
	COBO SC74/M91	Light driver		1.13 m/s ²	
		Heavy driver		0.75 m/s ²	

The company reserves the right to change the specifications without notice.

■ **NOTE**

- *1 : Manufacturer's estimate
- *2 : According to EN 15695-1:2009
- *3 : Measured according to Directive 2009/76/EC ANNEX II
- *4 : Measured according to Directive 2009/63/EC
- *5 : Measured according to Directive 78/764/EEC

9Y1210982INI0005US0

4. TRAVELING SPEEDS

[ROPS and CAB HST Type]

(At rated engine rpm)

Model		B2350 / B2650				
Tire size (Rear)		8-16 Farm	9.5-16 Farm	9.5-18 Farm	31 × 13.5-15 Turf	315/75D-15 Turf
	Range gear shift lever	km/h (mile/h)				
Forward	Low	0 to 4.61 (0 to 2.86)	0 to 4.94 (0 to 3.06)	0 to 5.24 (0 to 3.25)	0 to 4.55 (0 to 2.82)	0 to 4.98 (0 to 3.09)
	Middle	0 to 7.57 (0 to 4.70)	0 to 8.09 (0 to 5.02)	0 to 8.59 (0 to 5.33)	0 to 7.46 (0 to 4.63)	0 to 8.17 (0 to 5.07)
	High	0 to 19.12 (0 to 11.88)	0 to 20.45 (0 to 12.70)	0 to 21.71 (0 to 13.48)	0 to 18.85 (0 to 11.71)	0 to 20.65 (0 to 12.83)
	Max. Speed (at 2650 engine rpm)	20.27 (12.59)	21.68 (13.47)	23.01 (14.29)	19.98 (12.41)	21.89 (13.60)
Reverse	Low	0 to 3.69 (0 to 2.29)	0 to 3.95 (0 to 2.45)	0 to 4.19 (0 to 2.60)	0 to 3.64 (0 to 2.26)	0 to 3.99 (0 to 2.47)
	Middle	0 to 6.05 (0 to 3.75)	0 to 6.48 (0 to 4.02)	0 to 6.87 (0 to 4.26)	0 to 5.97 (0 to 3.70)	0 to 6.54 (0 to 4.06)
	High	0 to 15.29 (0 to 9.500)	0 to 16.36 (0 to 10.16)	0 to 17.37 (0 to 10.79)	0 to 15.08 (0 to 9.370)	0 to 16.52 (0 to 10.26)
	Max. Speed (at 2650 engine rpm)	16.21 (10.07)	17.34 (10.77)	18.41 (11.44)	15.98 (9.930)	17.51 (10.88)

Model		B3150	
Tire size (Rear)		12.4-16 Farm	13.6-16 Turf
	Range gear shift lever	km/h (mile/h)	
Forward	Low	0 to 5.57 (0 to 3.46)	
	Middle	0 to 9.14 (0 to 5.67)	
	High	0 to 23.09 (0 to 14.35)	
	Max. Speed (at 2650 engine rpm)	24.48 (15.21)	
Reverse	Low	0 to 4.46 (0 to 2.77)	
	Middle	0 to 7.31 (0 to 4.51)	
	High	0 to 18.47 (0 to 11.48)	
	Max. Speed (at 2650 engine rpm)	19.58 (12.17)	
		20.23 (12.57)	

The company reserves the right to change the specification without notice.

[ROPS Manual Transmission Type]

(At rated engine rpm)

Model			B2050 / B2350 / B2650				
Tire size (Rear)			8-16 Farm	9.5-16 Farm	9.5-18 Farm	31 × 13.5-15 Turf	315/75D-15 Turf
		Range gear shift lever	km/h (mile/h)				
Forward	1	Low	1.03 (0.640)	1.10 (0.684)	1.17 (0.727)	1.02 (0.634)	1.12 (0.696)
	2		1.71 (1.06)	1.83 (1.14)	1.95 (1.21)	1.69 (1.05)	1.85 (1.15)
	3		2.66 (1.65)	2.84 (1.76)	3.02 (1.88)	2.62 (1.63)	2.87 (1.78)
	4	Middle	1.92 (1.19)	2.05 (1.27)	2.18 (1.35)	1.89 (1.17)	2.07 (1.29)
	5		3.19 (1.98)	3.41 (2.12)	3.62 (2.25)	3.14 (1.95)	3.44 (2.14)
	6		4.94 (3.07)	5.29 (3.29)	5.61 (3.49)	4.87 (3.03)	5.34 (3.32)
	7	High	6.89 (4.28)	7.37 (4.58)	7.83 (4.87)	6.79 (4.22)	7.44 (4.62)
	8		11.43 (7.102)	12.23 (7.599)	12.98 (8.065)	11.27 (7.003)	12.35 (7.674)
	9		17.74 (11.02)	18.97 (11.79)	20.14 (12.51)	17.49 (10.87)	19.16 (11.91)
	9	Max.Speed (at 2650 engine rpm)	18.80 (11.68)	20.11 (12.50)	21.35 (13.27)	18.53 (11.51)	20.31 (12.62)
Reverse	1	Low	0.94 (0.58)	1.01 (0.628)	1.07 (0.665)	0.93 (0.58)	1.02 (0.634)
	2		1.57 (0.976)	1.67 (1.04)	1.78 (1.11)	1.54 (0.957)	1.69 (1.05)
	3		2.43 (1.51)	2.60 (1.62)	2.76 (1.71)	2.40 (1.49)	2.62 (1.63)
	4	Middle	1.76 (1.09)	1.88 (1.17)	1.99 (1.24)	1.73 (1.07)	1.90 (1.18)
	5		2.91 (1.81)	3.12 (1.94)	3.31 (2.06)	2.87 (1.78)	3.15 (1.96)
	6		4.52 (2.81)	4.83 (3.00)	5.13 (3.19)	4.46 (2.77)	4.88 (3.03)
	7	High	6.30 (3.91)	6.74 (4.19)	7.15 (4.44)	6.21 (3.86)	6.80 (4.23)
	8		10.45 (6.493)	11.18 (6.947)	11.87 (7.376)	10.30 (6.400)	11.29 (7.015)
	9		16.22 (10.08)	17.35 (10.78)	18.41 (11.44)	15.99 (9.936)	17.51 (10.88)
	9	Max.Speed (at 2650 engine rpm)	17.19 (10.68)	18.39 (11.43)	19.52 (12.13)	16.95 (10.53)	18.57 (11.54)

The company reserves the right to change the specification without notice.

9Y1210982INI0006US0

5. DIMENSIONS

Center ROPS

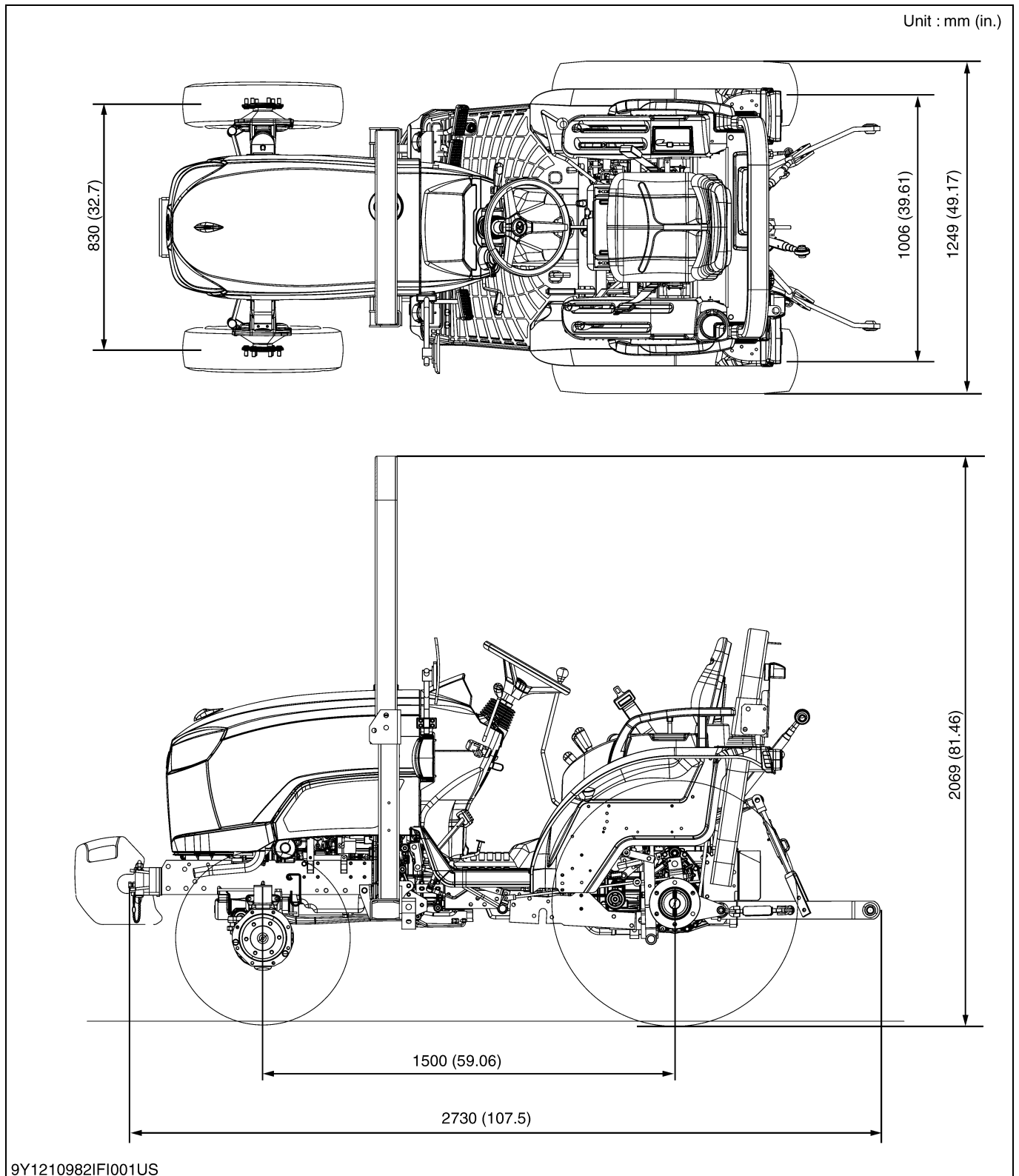

9Y1210982IFI001US

9Y1210982INI0007US0

ROPS

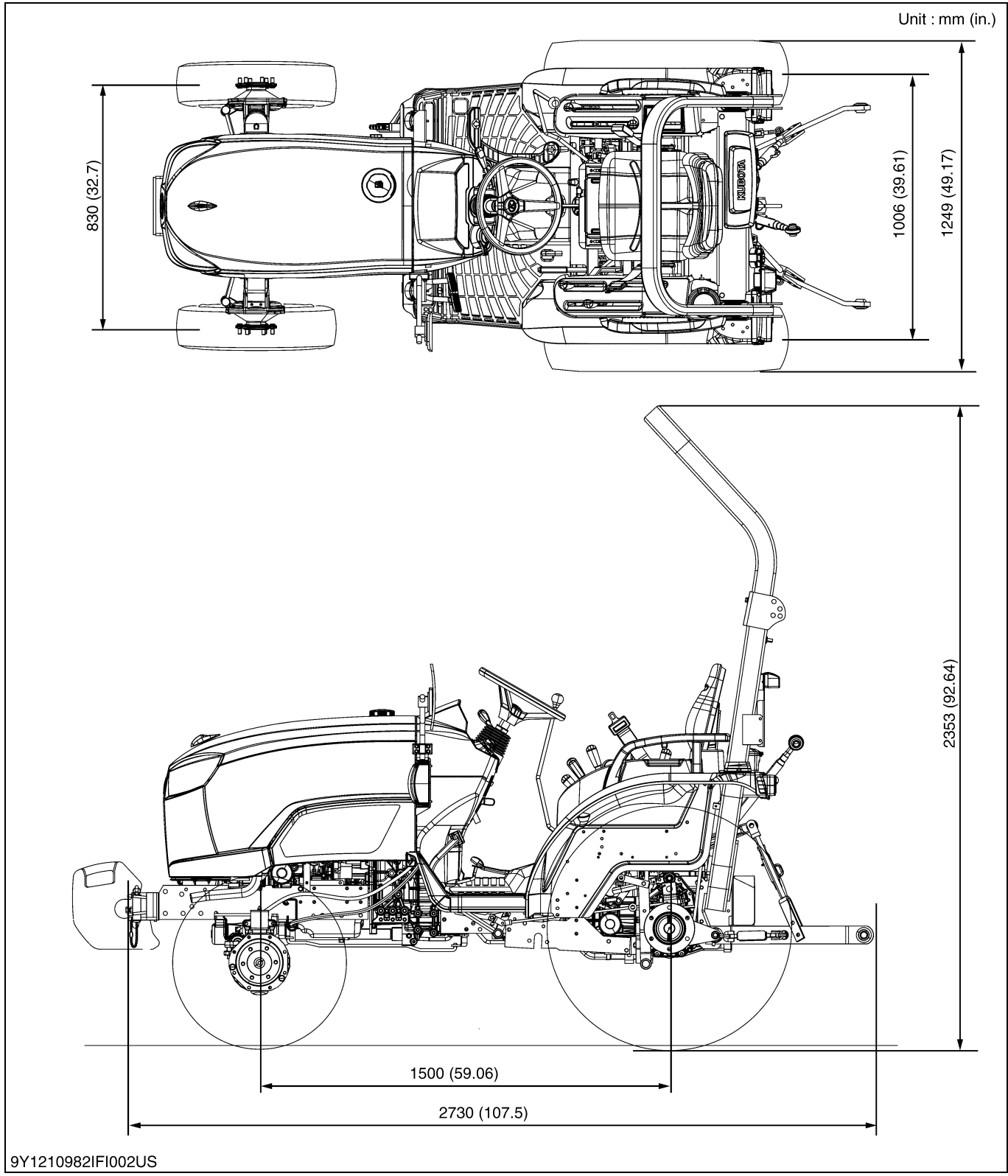

CABIN

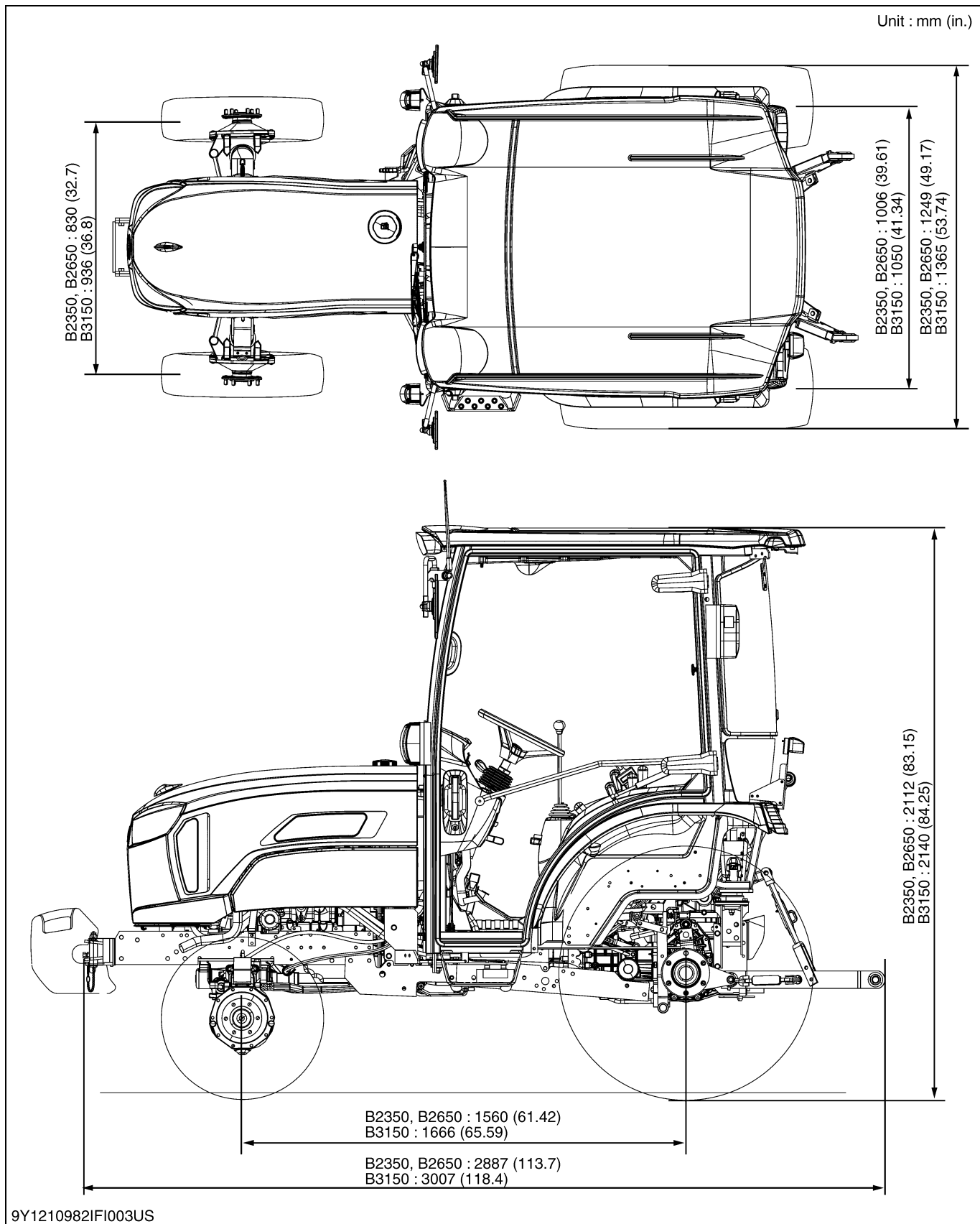

G GENERAL

GENERAL

CONTENTS

1. TRACTOR IDENTIFICATION.....	G-1
2. GENERAL PRECAUTIONS.....	G-2
3. HANDLING PRECAUTIONS FOR ELECTRICAL PARTS AND WIRING	G-3
[1] WIRING	G-3
[2] BATTERY	G-5
[3] FUSE	G-5
[4] CONNECTOR	G-5
[5] HANDLING OF CIRCUIT TESTER	G-6
[6] COLOR OF WIRING	G-7
4. LUBRICANTS, FUEL AND COOLANT	G-8
5. TIGHTENING TORQUES	G-10
[1] GENERAL USE SCREWS, BOLTS AND NUTS	G-10
[2] STUD BOLTS	G-10
[3] METRIC SCREWS, BOLTS AND NUTS	G-11
[4] AMERICAN STANDARD SCREWS, BOLTS AND NUTS WITH UNC OR UNF THREADS	G-11
[5] PLUGS	G-11
6. MAINTENANCE CHECK LIST	G-12
7. CHECK AND MAINTENANCE	G-14
[1] DAILY CHECK.....	G-14
[2] CHECK POINTS OF EVERY 50 HOURS	G-18
[3] CHECK POINTS OF EVERY 100 HOURS	G-22
[4] CHECK POINTS OF EVERY 200 HOURS	G-29
[5] CHECK POINTS OF EVERY 400 HOURS	G-34
[6] CHECK POINT OF EVERY 800 HOURS.....	G-36
[7] CHECK POINT OF EVERY 1500 HOURS.....	G-36
[8] CHECK POINT OF EVERY 3000 HOURS.....	G-36
[9] CHECK POINTS OF EVERY 1 YEAR.....	G-36
[10]CHECK POINTS OF EVERY 2 YEARS	G-37
[11]OTHERS.....	G-39
8. SPECIAL TOOLS	G-43
[1] SPECIAL TOOLS FOR ENGINE	G-43
[2] SPECIAL TOOLS FOR TRACTOR	G-50
[3] SPECIAL TOOLS FOR CABIN.....	G-53
9. TIRES	G-56
[1] TIRE PRESSURE.....	G-56
[2] WHEEL ADJUSTMENT.....	G-57
(1) Front Wheels	G-57
(2) Rear Wheels.....	G-58
[3] BALLAST.....	G-59
10. IMPLEMENT LIMITATIONS	G-61

1. TRACTOR IDENTIFICATION

When contacting your local KUBOTA distributor, always specify engine serial number, tractor serial number and hour meter reading.

- | | |
|----------------------------------|---|
| (1) Tractor Identification Plate | (4) ROPS Identification Plate
(ROPS Serial Number) |
| (2) Tractor Serial Number | (5) CABIN Identification Plate
(CABIN Serial Number) |
| (3) Engine Serial Number | |

9Y1210982GEG0001US0

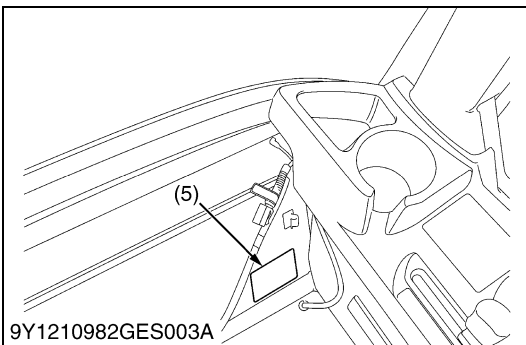
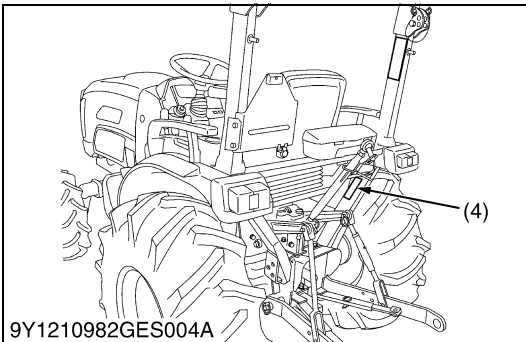
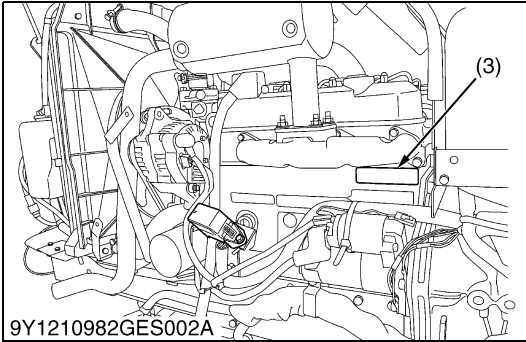
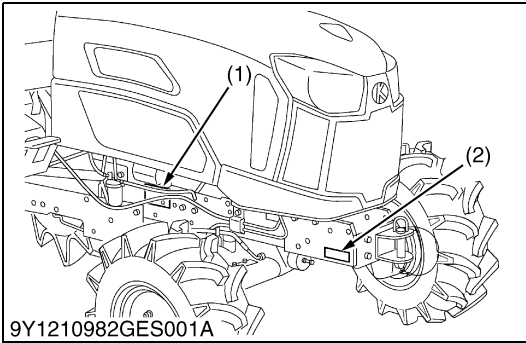

2. GENERAL PRECAUTIONS

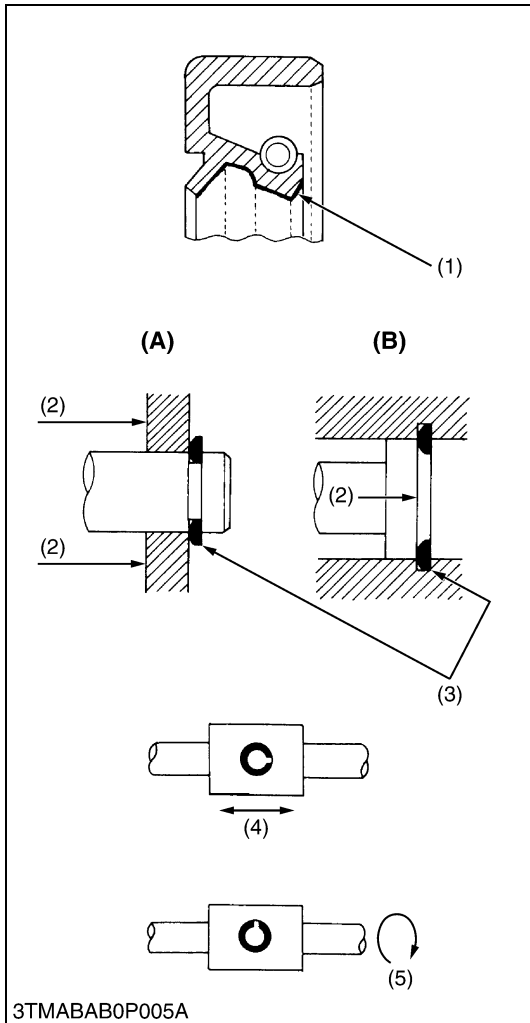

- When you disassemble, carefully put the parts in a clean area to make it easy to find the parts. You must install the screws, bolts and nuts in their initial position to prevent the reassembly errors.
- When it is necessary to use special tools, use KUBOTA special tools. Refer to the drawings when you make special tools that you do not use frequently.
- Before you disassemble or repair machine, make sure that you always disconnect the ground cable from the battery first.
- Remove oil and dirt from parts before you measure.
- Use only KUBOTA genuine parts for replacement to keep the machine performance and to make sure of safety.
- You must replace the gaskets and O-rings when you assemble again. Apply grease (1) to new O-rings or oil seals before you assemble.
- When you assemble the external or internal snap rings, make sure that the sharp edge (3) faces against the direction from which force (2) is applied.
- When inserting spring pins, their splits must face the direction from which a force is applied. See the figure left side.
- To prevent damage to the hydraulic system, use only specified fluid or equivalent.
- Clean the parts before you measure them.
- Tighten the fittings to the specified torque. Too much torque can cause damage to the hydraulic units or the fittings. Not sufficient torque can cause oil leakage.
- When you use a new hose or pipe, tighten the nuts to the specified torque. Then loosen (approx. by 45 °) and let them be stable before you tighten to the specified torque (This is not applied to the parts with seal tape).
- When you remove the two ends of a pipe, remove the lower end first.
- Use two pliers in removal and installation. One to hold the stable side, and the other to turn the side you remove to prevent twists.
- Make sure that the sleeves of flared connectors and tapers of hoses are free of dust and scratches.
- After you tighten the fittings, clean the joint and apply the maximum operation pressure 2 to 3 times to examine oil leakage.

- (1) Grease
- (2) Force
- (3) Sharp Edge
- (4) Axial Force
- (5) Rotating Movement

- (A) External Circlip
- (B) Internal Circlip

WSM000001GEG0106US0

3. HANDLING PRECAUTIONS FOR ELECTRICAL PARTS AND WIRING

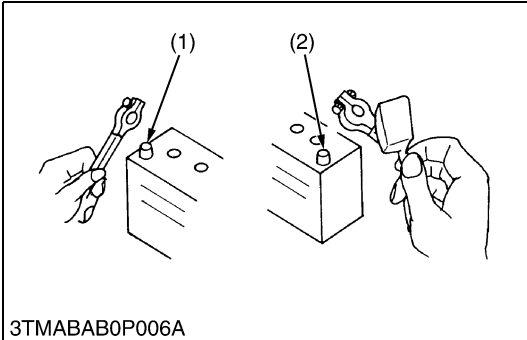

3TMABAB0P006A

To ensure safety and prevent damage to the machine and surrounding equipment, obey the following precautions in handling electrical parts and wiring.

■ **IMPORTANT**

- Check electrical wiring for damage and loosened connection every year. To this end, educate the customer to do his or her own check and at the same time recommend the dealer to perform periodic check for a fee.
- Do not try to modify or remodel any electrical parts and wiring.
- When removing the battery cables, disconnect the negative cable first. When installing the battery cables, connect the positive cable first.

- (1) Negative Terminal (2) Positive Terminal

WSM000001GEG0062US0

[1] WIRING

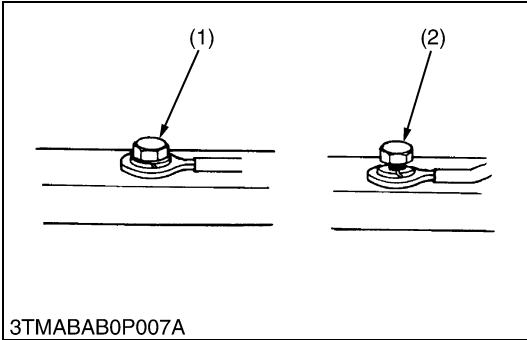

3TMABAB0P007A

- Securely tighten wiring terminals.

- (1) Correct (Securely Tighten) (2) Incorrect (Loosening Leads to Faulty Contact)

WSM000001GEG0063US0

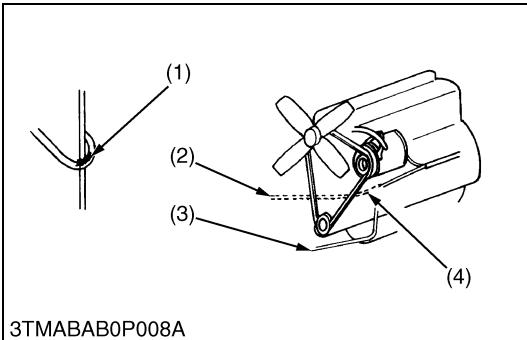

3TMABAB0P008A

- Do not let wiring contact dangerous part.

- (1) Dangerous Part (Sharp Edge) (2) Wiring (Incorrect) (3) Wiring (Correct) (4) Dangerous Part

WSM000001GEG0064US0

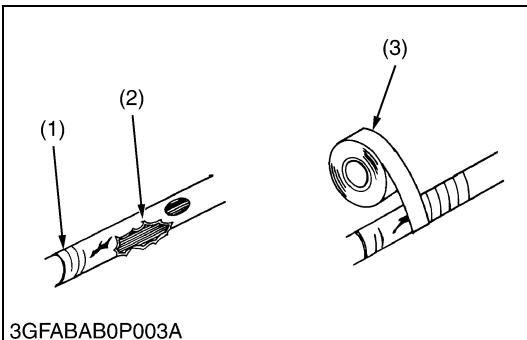

3GFABAB0P003A

- Repair or change torn or aged wiring immediately.

- (1) Aged (2) Torn (3) Insulating Vinyl Tape

WSM000001GEG0065US0

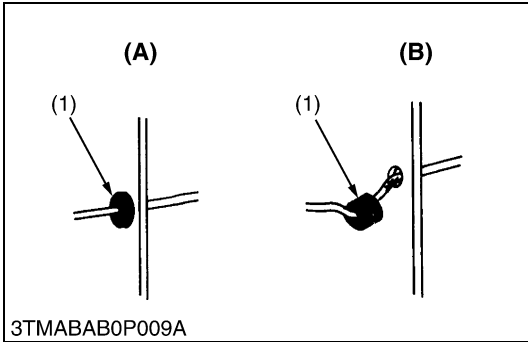

• Securely insert grommet.

- (1) Grommet
- (A) Correct
- (B) Incorrect

WSM000001GEG0066US0

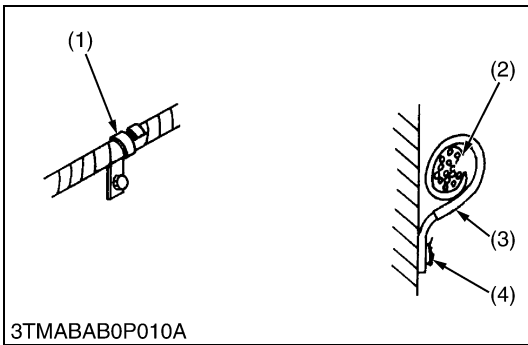

• Securely clamp, being careful not to damage wiring.

- (1) Clamp (Wind Clamp Spirally)
- (2) Wire Harness
- (3) Clamp
- (4) Welding Dent

WSM000001GEG0067US0

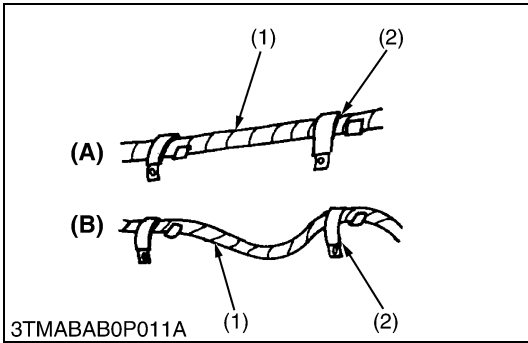

• Clamp wiring so that there is no twist, unnecessary sag, or excessive tension, except for movable part, where sag be required.

- (1) Wiring
- (2) Clamp
- (A) Correct
- (B) Incorrect

WSM000001GEG0068US0

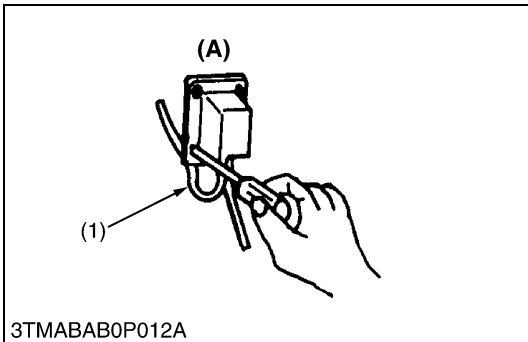

• In installing a part, be careful not to get wiring caught by it.

- (1) Wiring
- (A) Incorrect

WSM000001GEG0069US0

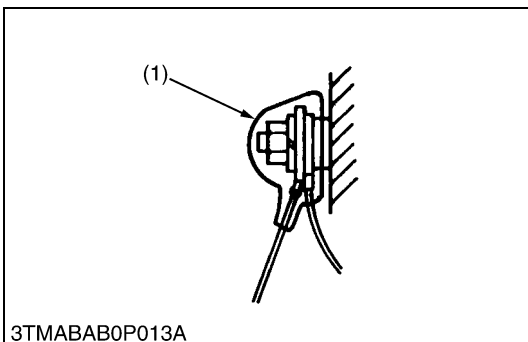

• After installing wiring, check protection of terminals and clamped condition of wiring.

- (1) Cover (Securely Install Cover)

WSM000001GEG0070US0

[2] BATTERY

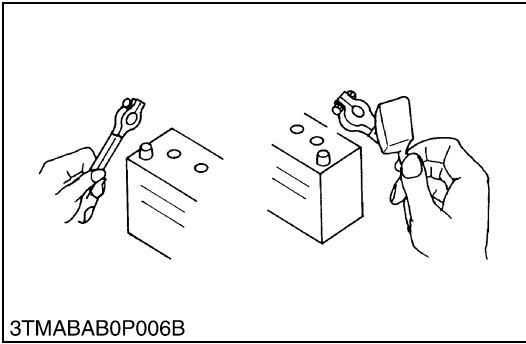

- Be careful not to confuse positive and negative terminal posts.
- When you remove battery cables, disconnect negative cable first. When you install battery cables, check for polarity and connect positive cable first.
- Do not install any battery with capacity other than is specified (Ah).
- After you connect cables to battery terminal posts, apply high temperature grease to them and securely install terminal covers on them.
- Do not allow dirt and dust to collect on battery.

⚠ CAUTION

- Be careful not to let battery liquid spill on your skin and clothes. If contaminated, wash it off with water immediately.
- Before you recharge the battery, remove it from the machine.
- Before you recharge, remove cell caps.
- Recharge in a well-ventilated place where there is no open flame nearby, as hydrogen gas and oxygen are formed.

WSM000001GEG0071US0

[3] FUSE

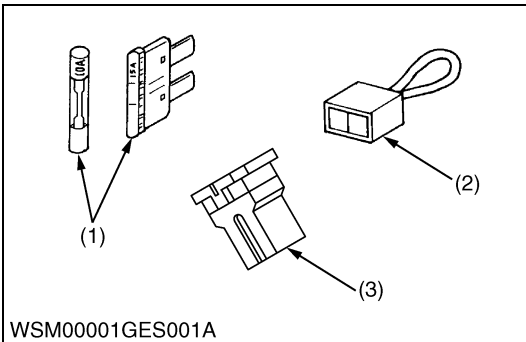

- Use fuses with specified capacity. Neither too large nor small capacity fuse is acceptable.
- Never use steel nor copper wire in place of fuse.
- Do not install working light, radio set, etc. on machine which is not provided with reserve power supply.
- Do not install accessories if fuse capacity of reserve power supply is exceeded.

- (1) Fuse (3) Slow Blow Fuse
 (2) Fusible Link

WSM000001GEG0072US0

[4] CONNECTOR

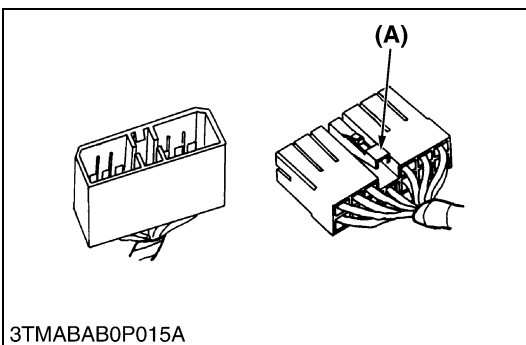

- For connector with lock, push lock to separate.

(A) Push

WSM000001GEG0073US0

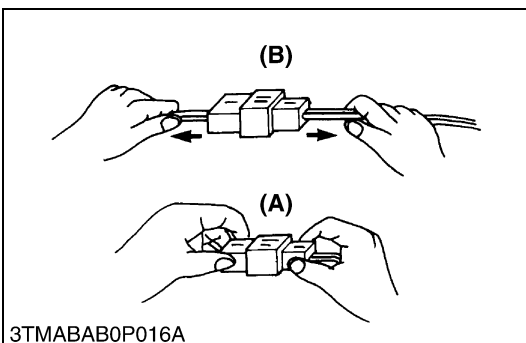

- In separating connectors, do not pull wire harnesses.
- Hold connector bodies to separate.

(A) Correct (B) Incorrect

WSM000001GEG0074US0

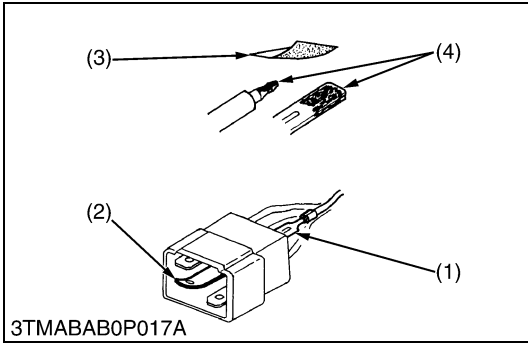

- Use sandpaper to remove rust from terminals.
- Repair deformed terminal. Make sure that there is no terminal being exposed or displaced.

- (1) Exposed Terminal
- (2) Deformed Terminal
- (3) Sandpaper
- (4) Rust

WSM000001GEG0075US0

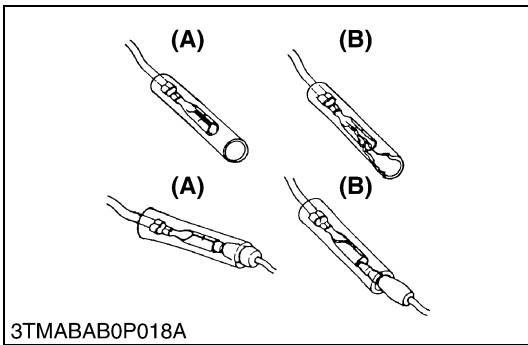

- Make sure that there is no female connector being too open.

- (A) Correct
- (B) Incorrect

WSM000001GEG0076US0

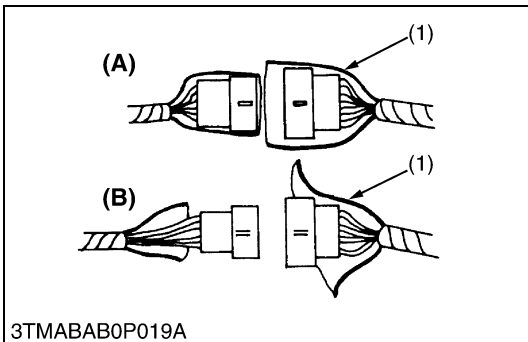

- Make sure that plastic cover is large enough to cover whole connector.

- (1) Cover
- (A) Correct
- (B) Incorrect

WSM000001GEG0077US0

[5] HANDLING OF CIRCUIT TESTER

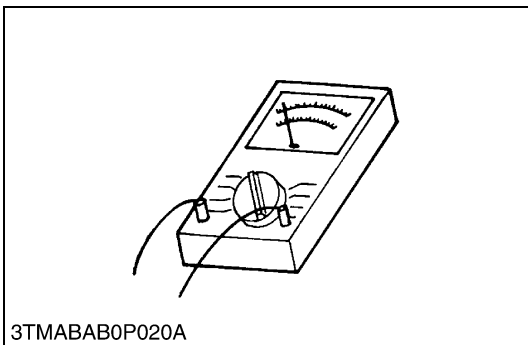

- Use tester correctly following manual provided with tester.
- Check for polarity and range.

WSM000001GEG0078US0

[6] COLOR OF WIRING

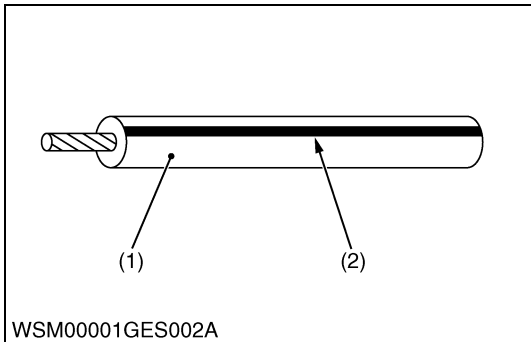

- Colors of wire are specified to the color codes.
- This symbol of "/" shows color with stripe(s).

(An example)

Red stripe on white color: W/R

Color of wiring	Color code
Black	B
Brown	Br
Green	G
Gray	Gy or Gr
Blue	L
Light Green	Lg
Orange	Or
Pink	P
Purple	Pu or V
Red	R
Sky Blue	Sb
White	W
Yellow	Y

(1) Wire Color

(2) Stripe

WSM000001GEG0079US0

4. LUBRICANTS, FUEL AND COOLANT

No.	Place	Capacity						Lubricants, fuel and coolant
		ROPS			CAB			
		B2050 B2350	B2650	B3150	B2350	B2650	B3150	
1	Fuel tank	27 L 7.1 U.S.gals 5.9 Imp.gals						<ul style="list-style-type: none"> No. 2-D diesel fuel No. 1-D diesel fuel if temperature is below -10 °C (14 °F)
2	Cooling system	4.6 L 4.9 U.S.qts 4.0 Imp.qts						Fresh clean soft water with anti-freeze
3	Engine crankcase	3.1 L 3.3 U.S.qts 2.7 Imp.qts	4.0 L 4.2 U.S.qts 3.5 Imp.qts	3.1 L 3.3 U.S.qts 2.7 Imp.qts	4.0 L 4.2 U.S.qts 3.5 Imp.qts			Engine oil : Refer to next page <ul style="list-style-type: none"> Above 25 °C (77 °F) SAE30, SAE10W-30 or 15W-40 -10 to 25 °C (14 to 77 °F) SAE20, SAE10W-30 or 15W-40 Below -10 °C (14 °F) SAE10W-30
4	Transmission case	17 L 4.49 U.S.gals 3.74 Imp.gals [HST Type]						KUBOTA UDT or SUPER UDT fluid*
		16.5 L 4.36 U.S.gals 3.63 Imp.gals [Manual Transmission Type]						
5	Front axle case	3.7 L 3.9 U.S.qts 3.3 Imp.qts	4.7 L 5.0 U.S.qts 4.1 Imp.qts	3.7 L 3.9 U.S.qts 3.3 Imp.qts	4.7 L 5.0 U.S.qts 4.1 Imp.qts	KUBOTA UDT or SUPER UDT fluid* or SAE80 - SAE90 gear oil		

	Greasing	No. of greasing point	Capacity	Type of grease
6	Top link	1	Until grease overflows	Multipurpose type grease NLGI-2 or NLGI-1 (GC-LB)
	Lift rod	1		
	Speed control pedal	1 [HST Type]		
	Brake pedal	1		
	Clutch pedal	1 [Manual Transmission Type]		
	Parking brake	1		
	Battery terminal	2	Moderate amount	

NOTE

- *KUBOTA UDT or SUPER UDT fluid --- KUBOTA original transmission hydraulic fluid

9Y1210982GEG0002US0

■ **NOTE**

Engine Oil

- Oil used in the engine should have an American Petroleum Institute (API) service classification and Proper SAE Engine Oil according to the ambient temperatures as shown above :
- With the emission control now in effect, the CF-4 and CG-4 lubricating oils have been developed for use of a low-sulfur fuel on on-road vehicle engines. When an off-road vehicle engine runs on a high-sulfur fuel, it is advisable to employ the "CF or better" lubricating oil with a high Total Base Number (TBN of 10 minimum).
- Refer to the following table for the suitable API classification engine oil according to the engine type (with internal EGR, external EGR or non-EGR) and the fuel (low-sulfur or high-sulfur fuel).

Fuel used	Engine oil classification (API classification)	
	Oil class of engines except external EGR	Oil class of engines with external EGR
High Sulfur Fuel [≥ 0.05 % (500 ppm)]	CF (If the "CF-4, CG-4, CH-4, or CI-4" lubricating oil is used with a high-sulfur fuel, change the lubricating oil at shorter intervals. (approximately half))	–
Low Sulfur Fuel [(< 0.05 % (500 ppm)] or Ultra Low Sulfur Fuel [< 0.0015 % (15 ppm)]	CF, CF-4, CG-4, CH-4 or CI-4	CF or CI-4 (Class CF-4, CG-4 and CH-4 engine oils cannot be used on EGR type engines)

EGR : Exhaust Gas Re-circulation

- **The CJ-4 engine oil is intended for DPF (Diesel Particulate Filter) type engines, and cannot be used on this tractor.**

	Without EGR	With external EGR
Models	B2050, B2350, B2650, B3150	–

Fuel

- Cetane number of 45 minimum. Cetane number greater than 50 is preferred, especially for temperatures below –20 °C (–4 °F) or elevations above 1500 m (5000 ft).
- If diesel fuel with sulfur content greater than 0.5 % (5000 ppm) sulfur content in used, reduce the service interval for engine oil and filter by 50%.
- NEVER use diesel fuel with sulfur content greater than 0.05 % (500 ppm) for EXTERNAL EGR type engine.
- DO NOT use diesel fuel with sulfur content greater than 1.0 % (10000 ppm).
- Diesel fuels specified to EN 590 or ASTM D975 are recommended.
- No.2-D is a distillate fuel of lower volatility for engine in industrial and heavy mobile service. (SAE J313 JUN87)
- Since this engine adopts EPA Tier 4 and Interim Tier 4 standards, the use of low sulfur fuel or ultra low sulfur fuel is mandatory in EPA regulated area (North America). Therefore, please use No.2-D S500 or S15 diesel fuel as an alternative to No.2-D, or use No.1-D S500 or S15 diesel fuel as an alternative to No.1-D if outside air temperature is below –10 °C (14 °F).

Transmission oil

- The oil used to lubricate the transmission is also used as hydraulic fluid. To insure proper operation of the hydraulic system and to complete lubrication of the transmission, it is important that a multi-grade transmission fluid is used in this system. We recommend the use of KUBOTA UDT or SUPER UDT fluid for optimum protection and performance.
Do not mix different brands together.



■ Indicated capacities of water and oil are manufacturer's estimate.

9Y1210982GEG0003US0

5. TIGHTENING TORQUES

[1] GENERAL USE SCREWS, BOLTS AND NUTS

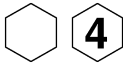
Tighten screws, bolts and nuts whose tightening torques are not specified in this Workshop Manual according to the table below.

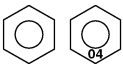
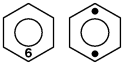
Indication on top of bolt	 No-grade or 4T						 7T						 9T		
Indication on top of nut	 No-grade or 4T												 6T		
Material of opponent part	Ordinariness			Aluminum			Ordinariness			Aluminum			Ordinariness		
Unit	N·m	kgf·m	lbf·ft	N·m	kgf·m	lbf·ft	N·m	kgf·m	lbf·ft	N·m	kgf·m	lbf·ft	N·m	kgf·m	lbf·ft
M6	7.9	0.80	5.8	7.9	0.80	5.8	9.81	1.00	7.24	7.9	0.80	5.8	12.3	1.25	9.05
	to 9.3	to 0.95	to 6.8	to 8.8	to 0.90	to 6.5	to 11.2	to 1.15	to 8.31	to 8.8	to 0.90	to 6.5	to 14.2	to 1.45	to 10.4
M8	18	1.8	13	17	1.7	13	24	2.4	18	18	1.8	13	30	3.0	22
	to 20	to 2.1	to 15	to 19	to 2.0	to 14	to 27	to 2.8	to 20	to 20	to 2.1	to 15	to 34	to 3.5	to 25
M10	40	4.0	29	32	3.2	24	48	4.9	36	40	4.0	29	61	6.2	45
	to 45	to 4.6	to 33	to 34	to 3.5	to 25	to 55	to 5.7	to 41	to 44	to 4.5	to 32	to 70	to 7.2	to 52
M12	63	6.4	47	-	-	-	78	7.9	58	63	6.4	47	103	10.5	76.0
	to 72	to 7.4	to 53	-	-	-	to 90	to 9.2	to 66	to 72	to 7.4	to 53	to 117	to 12.0	to 86.7
M14	108	11.0	79.6	-	-	-	124	12.6	91.2	-	-	-	167	17.0	123
	to 125	to 12.8	to 92.5	-	-	-	to 147	to 15.0	to 108	-	-	-	to 196	to 20.0	to 144
M16	167	17.0	123	-	-	-	197	20.0	145	-	-	-	260	26.5	192
	to 191	to 19.5	to 141	-	-	-	to 225	to 23.0	to 166	-	-	-	to 304	to 31.0	to 224
M18	246	25.0	181	-	-	-	275	28.0	203	-	-	-	344	35.0	254
	to 284	to 29.0	to 209	-	-	-	to 318	to 32.5	to 235	-	-	-	to 402	to 41.0	to 296
M20	334	34.0	246	-	-	-	368	37.5	272	-	-	-	491	50.0	362
	to 392	to 40.0	to 289	-	-	-	to 431	to 44.0	to 318	-	-	-	to 568	to 58.0	to 419

WSM000001GEG0001US0

[2] STUD BOLTS

Material of opponent part	Ordinariness			Aluminum		
Unit	N·m	kgf·m	lbf·ft	N·m	kgf·m	lbf·ft
M8	12	1.2	8.7	8.9	0.90	6.5
	to 15	to 1.6	to 11	to 11	to 1.2	to 8.6
M10	25	2.5	18	20	2.0	15
	to 31	to 3.2	to 23	to 25	to 2.6	to 18
M12	30	3.0	22	31	3.2	23
	to 49	to 5.0	to 36			
M14	62	6.3	46	-	-	-
	to 73	to 7.5	to 54			
M16	98.1	10.0	72.4	-	-	-
	to 112	to 11.5	to 83.1			
M18	172	17.5	127	-	-	-
	to 201	to 20.5	to 148			

WSM000001GEG0002US0

[3] METRIC SCREWS, BOLTS AND NUTS

Grade	8.8 Property class 8.8			10.9 Property class 10.9			
	Unit	N·m	kgf·m	lbf·ft	N·m	kgf·m	lbf·ft
M8		24 to 27	2.4 to 2.8	18 to 20	30 to 34	3.0 to 3.5	22 to 25
M10		48 to 55	4.9 to 5.7	36 to 41	61 to 70	6.2 to 7.2	45 to 52
M12		78 to 90	7.9 to 9.2	58 to 66	103 to 117	10.5 to 12.0	76.0 to 86.7
M14		124 to 147	12.6 to 15.0	91.2 to 108	167 to 196	17.0 to 20.0	123 to 144
M16		197 to 225	20.0 to 23.0	145 to 166	260 to 304	26.5 to 31.0	192 to 224



WSM000001GEG0003US0

[4] AMERICAN STANDARD SCREWS, BOLTS AND NUTS WITH UNC OR UNF THREADS

Grade	SAE GR.5			SAE GR.8			
	Unit	N·m	kgf·m	lbf·ft	N·m	kgf·m	lbf·ft
1/4		11.7 to 15.7	1.20 to 1.60	8.63 to 11.5	16.3 to 19.7	1.67 to 2.00	12.0 to 14.6
5/16		23.1 to 27.7	2.36 to 2.82	17.0 to 20.5	33 to 39	3.4 to 3.9	25 to 28
3/8		48 to 56	4.9 to 5.7	36 to 41	61 to 73	6.3 to 7.4	45 to 53
1/2		110 to 130	11.3 to 13.2	81.2 to 95.8	150 to 178	15.3 to 18.1	111 to 131
9/16		150 to 178	15.3 to 18.1	111 to 131	217 to 260	22.2 to 26.5	160 to 191
5/8		204 to 244	20.8 to 24.8	151 to 179	299 to 357	30.5 to 36.4	221 to 263

WSM000001GEG0008US0

[5] PLUGS

Shape	Size	Material of opponent part					
		Ordinariness			Aluminum		
		N·m	kgf·m	lbf·ft	N·m	kgf·m	lbf·ft
Tapered screw 	R1/8	13 to 21	1.3 to 2.2	9.4 to 15	13 to 19	1.3 to 2.0	9.4 to 14
	R1/4	25 to 44	2.5 to 4.5	18 to 32	25 to 34	2.5 to 3.5	18 to 25
	R3/8	49 to 88	5.0 to 9.0	37 to 65	49 to 58	5.0 to 6.0	37 to 43
	R1/2	58.9 to 107	6.00 to 11.0	43.4 to 79.5	59 to 78	6.0 to 8.0	44 to 57
Straight screw 	G1/4	25 to 34	2.5 to 3.5	18 to 25	–	–	–
	G3/8	62 to 82	6.3 to 8.4	46 to 60	–	–	–
	G1/2	49 to 88	5.0 to 9.0	37 to 65	–	–	–

WSM000001GEG0005US0

6. MAINTENANCE CHECK LIST

No.	Item		Indication on hour meter														Interval	Reference page			
			50	100	150	200	250	300	350	400	450	500	550	600	650	700				800	
1	Clogging of air conditioner condenser screen [CAB only]	Clean																	Daily	G-16	
2	Engine oil	Change	★			☆				☆				☆			☆	every 200 Hr	G-29		
3	Engine oil filter	Replace	★			☆				☆				☆			☆	every 200 Hr	G-29		
4	Transmission oil filters [HST}	Replace	★			☆				☆				☆			☆	every 200 Hr	G-30		
5	Hydraulic oil filter	Replace	★							☆							☆	every 400 Hr	G-35		
6	Transmission fluid	Change								☆							☆	every 400 Hr	G-34		
7	Front axle case oil	Change								☆							☆	every 400 Hr	G-35		
8	Front axle pivot	Adjust								☆							☆	every 400 Hr	G-36		
9	Engine start system	Check	☆	☆	☆	☆	☆	☆	☆	☆	☆	☆	☆	☆	☆	☆	☆	every 50 Hr	G-18		
10	Greasing	–	☆	☆	☆	☆	☆	☆	☆	☆	☆	☆	☆	☆	☆	☆	☆	every 50 Hr	G-20		
11	Wheel bolt torque	Check	☆	☆	☆	☆	☆	☆	☆	☆	☆	☆	☆	☆	☆	☆	☆	every 50 Hr	G-21		
12	Battery condition	Check		☆		☆		☆		☆		☆		☆		☆	☆	every 100 Hr	G-22	*4	
13	Air cleaner element [Single type]	Clean		☆		☆		☆		☆		☆		☆		☆	☆	every 100 Hr	G-24	*1	
		Replace																every 1 year	G-24	*2	
14	Air cleaner element [Double element type] Primary element	Clean		☆		☆		☆		☆		☆		☆		☆	☆	every 100 Hr	G-25	*1	
		Replace																every 1 year	G-25	*2	
15	Fuel filter element	Clean		☆		☆		☆		☆		☆		☆		☆	☆	every 100 Hr	G-26		
		Replace								☆							☆	every 400 Hr	G-26		
16	Fan belt	Adjust		☆		☆		☆		☆		☆		☆		☆	☆	every 100 Hr	G-26		
17	Clutch	Adjust	★	☆		☆		☆		☆		☆		☆		☆	☆	every 100 Hr	G-28		
18	Brake	Adjust		☆		☆		☆		☆		☆		☆		☆	☆	every 100 Hr	G-27		
19	Parking brake	Adjust		☆		☆		☆		☆		☆		☆		☆	☆	every 100 Hr	G-28, 5-S5		
20	Tension of air conditioner drive belt [CAB only]	Adjust				☆				☆				☆			☆	every 200 Hr	G-32		
21	Clogging of inner air filter [CAB only]	Clean				☆				☆				☆			☆	every 200 Hr	G-32		
22	Clogging of fresh air filter [CAB only]	Clean				☆				☆				☆			☆	every 200 Hr	G-33		
23	Clogging of air conditioner condenser [CAB only]	Clean				☆				☆				☆			☆	every 200 Hr	G-33		
24	Power steering oil line	Check				☆				☆				☆			☆	every 200 Hr	G-32		
		Replace																every 2 years	G-32		

No.	Item		Indication on hour meter													Interval	Reference page				
			50	100	150	200	250	300	350	400	450	500	550	600	650				700	800	
25	Radiator hose and clamp	Check				☆				☆					☆			☆	every 200 Hr	G-31	
		Replace																	every 2 years	G-31, G-37	
26	Fuel line	Check		☆		☆		☆		☆		☆		☆		☆		every 100 Hr	G-28		
		Replace																every 2 years	G-28	*3	
27	Intake air line	Check				☆				☆					☆			every 200 Hr	G-30		
		Replace																every 2 years	G-30	*3	
28	Toe-in	Adjust				☆				☆				☆			every 200 Hr	G-31			
29	Engine valve clearance	Adjust														☆	every 800 Hr	1-S15			
30	Fuel injection nozzle injection pressure	Check															every 1500 Hr	1-S19			
31	Injection pump	Check															every 3000 Hr	1-S20			
32	Air conditioner pipes and hoses [CAB only]	Check															every 1 year	G-36			
		Replace															every 2 years	10-M1, 10-S17			
33	CAB isolation cushion [CAB only]	Check															every 1 year	G-36			
34	Cooling system	Flush															every 2 years	G-37			
35	Coolant	Change															every 2 years	G-37			
36	Fuel system	Bleed															Service as required	G-39			
37	Clutch housing water	Drain														G-39					
38	Fuse	Replace														G-40					
39	Light bulb	Replace														G-41					
40	Lubricating points [CAB only]	-														G-41					
41	Washer liquid [CAB only]	Check														G-41					
42	Amount of refrigerant (gas) [CAB only]	Check														G-42					

■ **IMPORTANT**

- The jobs indicated by ☆ must be done after the first 50 hours of operation.
- *1 Air cleaner should be cleaned more often in severe dusty conditions.
- *2 Every year or after 6 cleanings.
- *3 Replace only if necessary.
- *4 When the battery is used for less than 100 hours per year, check the fluid level annually.

9Y1210982GEG0004US0

7. CHECK AND MAINTENANCE

[1] DAILY CHECK

⚠ WARNING

To avoid personal injury or death:
Take the following precautions when checking the tractor.

- Park the machine on firm and level ground.
- Set the parking brake.
- Lower the implement to the ground.
- All residual pressure of the hydraulic system released.
- Stop the engine and remove the key.

9Y1210982GEG0005US0

Walk Around Inspection

1. Look around and under the tractor for such items as loose bolts, trash build-up, oil or coolant leaks, broken or worn parts.

9Y1210982GEG0006US0

Checking and Refueling

⚠ WARNING

To avoid personal injury or death:

- Do not smoke while refueling.
- Be sure to stop the engine before refueling.

1. Turn the key switch to "ON", check the amount of fuel by fuel gauge.
2. Fill fuel tank when fuel gauge shows 1/4 or less fuel in tank.
3. Use grade No.2-Diesel fuel at temperatures above -10 °C (14 °F).
Use grade No.1-Diesel fuel at temperatures below -10 °C (14 °F).

■ IMPORTANT

- Do not permit dirt or trash to get into the fuel system.
- Be careful not to let the fuel tank become empty, otherwise air will enter the fuel system, necessitating bleeding before next engine start.
- Be careful not to spill during refueling. If you should spill, wipe it off at once, or it may cause a fire.
- To prevent condensation (water) accumulation in the fuel tank, fill the tank before parking overnight.

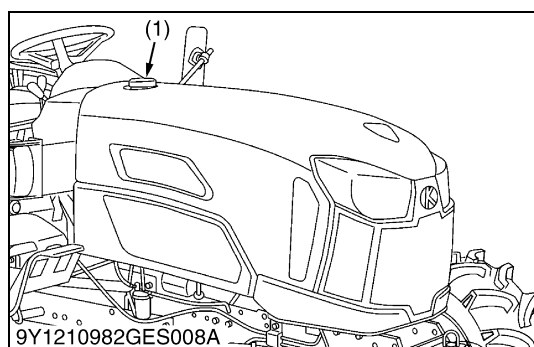

Fuel tank capacity	27 L 7.1 U.S.gals 5.9 Imp.gals
--------------------	--------------------------------------

(1) Fuel Tank Cap

9Y1210982GEG0007US0

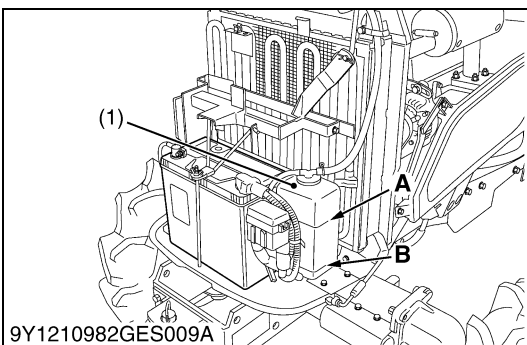
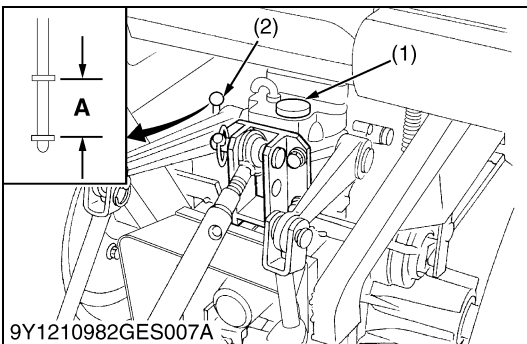
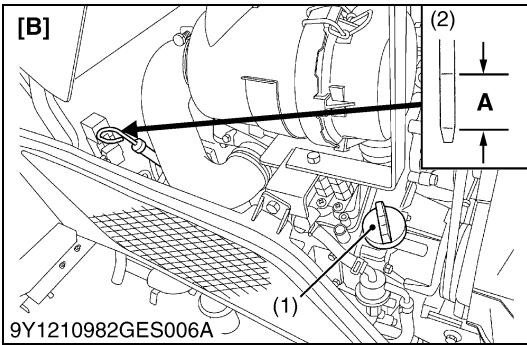
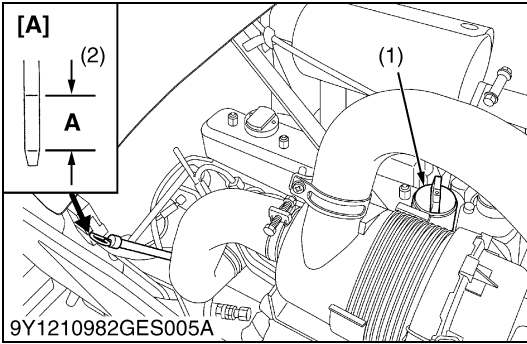

Checking Engine Oil Level

CAUTION

To avoid personal injury:

- Be sure to stop the engine before checking the oil level.
1. Park the machine on a flat surface.
 2. Check engine oil before starting the engine or 5 minutes or more after the engine has stopped.
 3. To check the oil level, draw out the dipstick, wipe it clean, replace it, and draw it out again. Check to see that the oil level lies between the two notches.

If the level is too low, add new oil to the prescribed level at the oil inlet.

IMPORTANT

- When using an oil of different maker or viscosity from the previous one, remove all of the old oil. Never mix two different types of oil.
- If oil level is low, do not run engine.

- (1) Oil Inlet
- (2) Dipstick

A: Oil level is acceptable within this range.

[A] B2050, B2350, B3150
[B] B2650

9Y1210982GEG0008US0

Checking Transmission Fluid Level

1. Park the machine on a flat surface, lower the implement and shut off engine.
2. To check the oil level, draw out the dipstick, wipe it clean, replace it, and draw it out again. Check to see that the oil level lies within the cross hatched area.

If the level is too low, add new oil to the prescribed level at the oil inlet.

IMPORTANT

- If oil level is low, do not run engine.

- (1) Oil Inlet
- (2) Dipstick

A: Oil level is acceptable within this range.

9Y1210982GEG0009US0

Checking Coolant Level

WARNING

To avoid personal injury or death:

- Do not remove radiator cap while coolant is hot. When cool, slowly rotate cap to the first stop and allow sufficient time for excess pressure to escape before removing the cap completely.

1. Check to see that the coolant level is between the "FULL" and "LOW" marks of recovery tank.
2. When the coolant level drops due to evaporation, add soft water only up to the full level.
In case of leakage, add anti-freeze and soft water in the specified mixing ratio up to the full level.

IMPORTANT

- If the radiator cap has to be removed, follow the caution above and securely retighten the cap.
- Use clean, fresh soft water and anti-freeze to fill the recovery tank.

- (1) Recovery Tank

(A) "FULL"
(B) "LOW"

9Y1210982GEG0010US0

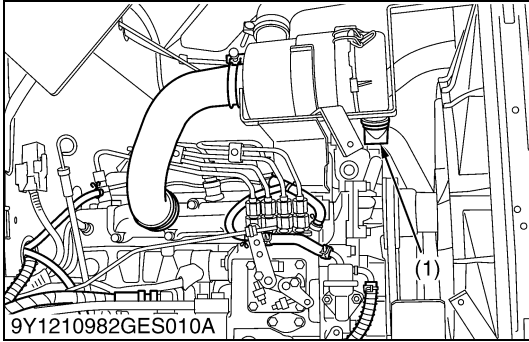

Cleaning Evacuator Valve

1. Open the evacuator valve to get rid of large particles of dust and dirt.

(1) Evacuator Valve

9Y1210982GEG0011US0

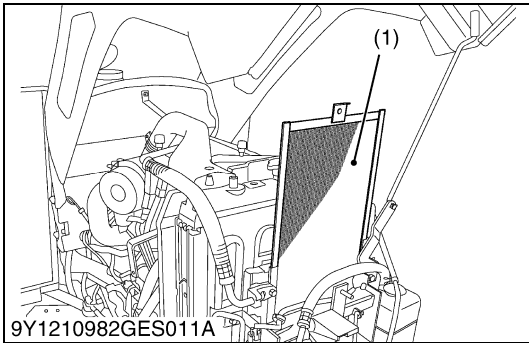

Cleaning Air Conditioner Condenser Screen [CABIN]

! WARNING

To avoid personal injury or death:

- Be sure to stop the engine before removing the screen.
- The condenser and receiver become hot while the air conditioner is running. Before checking or cleaning them, wait long enough until they cool down.

1. Detach the air conditioner condenser screen and remove all foreign materials.

■ IMPORTANT

- Grill and screen must be clean from debris to prevent engine from overheating and to allow good air intake for air cleaner.

(1) Air Conditioner Condenser Screen

9Y1210982GEG0012US0

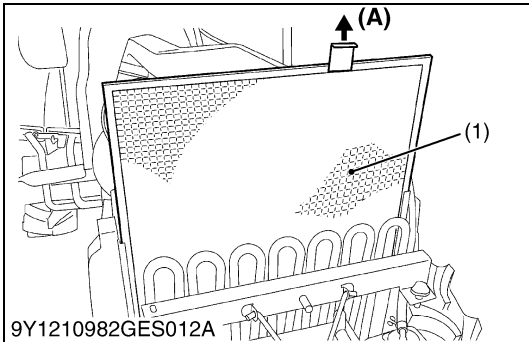

Cleaning Grill and Radiator Screen

! WARNING

To avoid personal injury or death:

- Be sure to stop the engine and remove the key before removing the screen.
- The condenser and receiver become hot while the air conditioner is running. Before checking or cleaning them, wait long enough until they cool down.

1. Check front grill and side screens to be sure they are clean of debris.
2. Detach the screen and remove all foreign material and clean the front of radiator completely.

■ IMPORTANT

- Grill and screen must be clean from debris to prevent engine from overheating and to allow good air intake for the air cleaner.

(1) Radiator Screen

(A) "DETACH"

9Y1210982GEG0013US0

Checking Brake Pedal

1. Inspect the brake pedals for free travel, and smooth operation.
2. Adjust if incorrect measurement is found.

9Y1210982GEG0014US0

Checking Gauges, Meter and Easy Checker™

1. Inspect the instrument panel for broken gauge(s), meter(s) and Easy Checker™.
2. Replace if broken.

9Y1210982GEG0015US0

Checking Head Light, Hazard Light etc.

1. Inspect the light for broken bulbs and lenses.
2. Replace if broken.

9Y1210982GEG0016US0

Checking Seat Belt and ROPS

1. Always check condition of seat belt and ROPS attaching hardware before operating tractor.
2. Replace if damaged.

9Y1210982GEG0017US0

Checking Clutch Pedal [ROPS Manual Transmission Type]

1. Inspect the clutch pedals for free travel, and smooth operation.
2. Adjust if incorrect measurement is found: (See "Adjusting Clutch Pedal" in "EVERY 100 HOURS".)

9Y1210982GEG0018US0

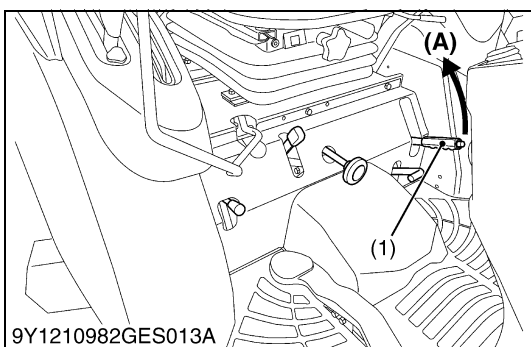

9Y1210982GES013A

Checking Parking Brake Lever

⚠ WARNING

To avoid personal injury or death:

- Stop the engine and chock the wheels before checking parking brake lever.

Proper parking brake lever free travel	2 notches (Ratchet sound 2)
--	-----------------------------

1. Please raise the lever to the parking position while counting the ratchet sound made by the parking brake lever.

(1) Parking Brake Lever (A) "PULL"

9Y1210982GEG0019US0

Checking and Cleaning of Electrical Wiring and Battery Cables

⚠ WARNING

To avoid personal injury or death:

- A loosened terminal or connector, or damaged wire may affect the performance of electrical components or cause short circuits. Leakage of electricity could result in a fire hazard, a dead battery or damage to electrical components.
- Replace damaged wires or connections promptly.
- If a fuse blows soon after replacement, DO NOT USE A LARGER THAN RECOMMENDED FUSE OR BYPASS THE FUSE SYSTEM.
- Many wiring connections are protected by waterproof plugs, plug and unplug these connections carefully and make sure they are sealed correctly after assembly.
- Accumulation of dust, chaff or spilled fuel deposits around the battery, electrical wiring, engine or exhaust system are a fire hazard.

CLEAN THESE AREAS BEFORE STARTING WORK.

To avoid premature electrical malfunctions DO NOT APPLY high pressure water directly to battery, wiring, connectors, electrical components or instrument panel.

Inspect the following regularly:

1. Check wiring for chafed or cracked insulation.
2. Check wiring harness clamps. Replace if necessary.
3. Check connectors and terminals for looseness, contamination or overheated (discolored) connectors.
4. Check instrument panel for correct operation of switches and gauges.

9Y1210982GEG0020US0

Checking Movable Parts

1. If any of the movable parts, such as levers and pedals, is not smoothly moved because of rust or anything sticky, do not attempt to force it into motion.
In the above case, remove the rust or sticky thing, and apply oil or grease on the relevant spot.
Otherwise, the machine may get damaged.

9Y1210982GEG0021US0

[2] CHECK POINTS OF EVERY 50 HOURS

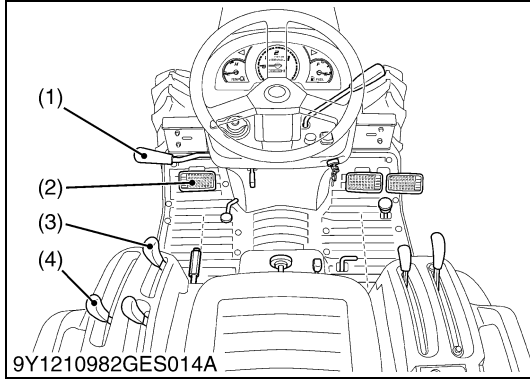

Checking Engine Start System [ROPS Manual Transmission Type]

⚠ WARNING

To avoid personal injury or death:

- Do not allow anyone near the tractor while testing.
- If the tractor does not pass the test do not operate the tractor.
- Detach an implement before testing.

■ Preparation before testing.

1. Sit on operator's seat.
2. Set the parking brake and stop the engine.
3. Shift the range gear shift lever to "NEUTRAL" position.
4. Shift the shuttle shift lever in "NEUTRAL" position.
5. Shift the PTO ON-OFF lever to "OFF" position.
6. Fully depress the clutch pedal.

■ Test : Switch for the shuttle shift lever.

1. Shift the shuttle shift lever to the forward position.
2. Fully depress the clutch pedal and turn the key to "START" position.
3. The engine must not crank.
4. Reverse position of the shuttle shift lever checks similarly.

■ Test : Switch for the PTO ON-OFF lever.

1. Shift the PTO ON-OFF lever to "ON" position.
2. Shift the shuttle shift lever to the "NEUTRAL" position.
3. Fully depress the clutch pedal and turn the key to "START" position.
4. The engine must not crank.

■ Test : Switches for the operator's seat and the PTO ON-OFF lever.

1. Sit on the operator's seat.
2. Start the engine.
3. Fully depress the clutch pedal.
4. Shift the PTO ON-OFF lever to "ON" position.
5. Release the clutch pedal and parking brake.
6. Stand up. (Do not get off the machine.)
7. The engine must shut off after approximately 1 second.

- (1) Shuttle Shift Lever
(2) Clutch Pedal

- (3) PTO ON-OFF Lever
(4) Range Gear Shift Lever

9Y1210982GEG0022US0

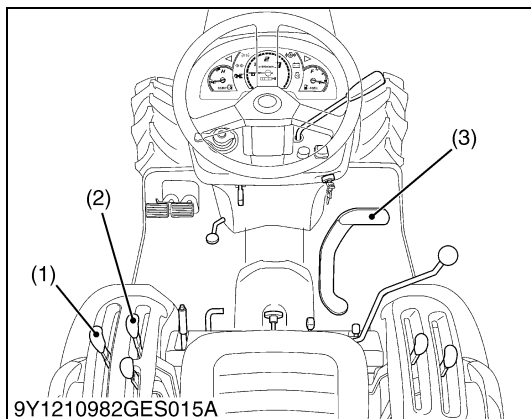

Checking Engine Start System [ROPS and CAB HST Type]

⚠ WARNING

To avoid personal injury or death:

- Do not allow anyone near the tractor while testing.
- If the tractor does not pass the test do not operate the tractor.
- Detach an implement before testing.

■ Preparation before testing.

1. Sit on operator's seat.
2. Set the parking brake and stop the engine.
3. Shift the range gear shift lever to "NEUTRAL" position.
4. Place the speed control pedal in "NEUTRAL" position.
5. Shift the PTO clutch lever to "OFF" position.

■ Test : Switch for the speed control pedal.

1. Depress the speed control pedal.
2. Turn the key to "START" position.
3. The engine must not crank.

■ Test : Switch for the PTO clutch lever.

1. Place the speed control pedal in "NEUTRAL" position.
2. Shift the PTO clutch lever to "ON" position.
3. Turn the key to "START" position.
4. The engine must not crank.

■ Test : Switches for the operator's seat and the PTO clutch lever.

1. Sit on the operator's seat.
2. Start the engine.
3. Shift the PTO clutch lever to "ON" position.
4. Release the parking brake.
5. Stand up. (Do not get off the machine.)
6. The engine must shut off after approximately 1 second.

(1) Range Gear Shift Lever

(2) PTO Clutch Lever

(3) Speed Control Pedal

9Y1210982GEG0023US0

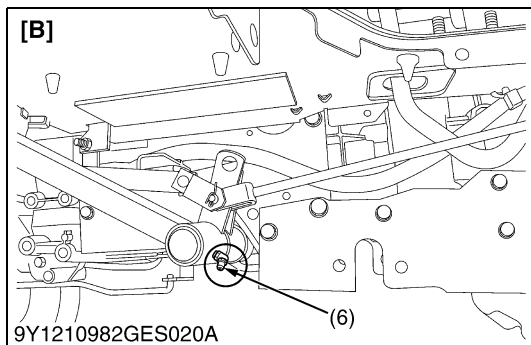
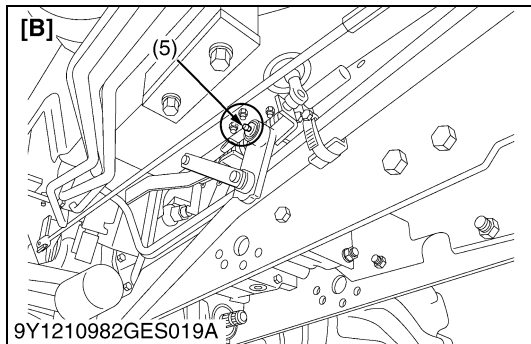
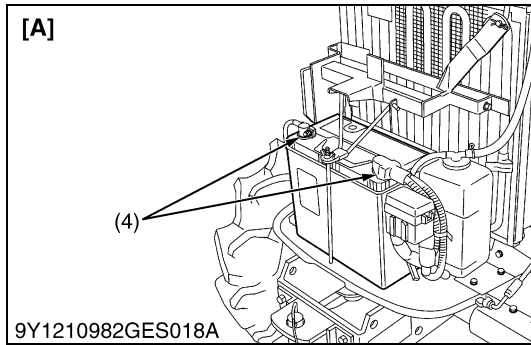
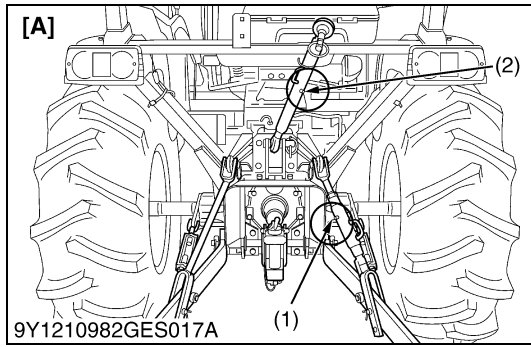
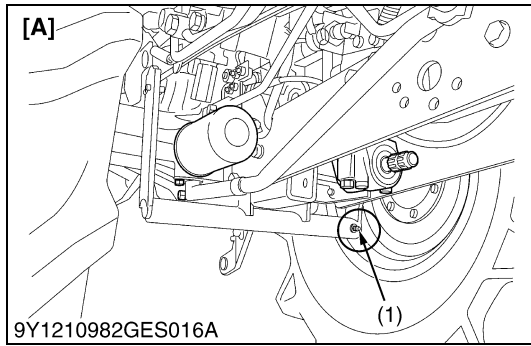

Lubricating Grease Fittings

1. Apply a small amount of multipurpose grease to the following points every 50 hours:
If you operated the machine in extremely wet and muddy conditions, lubricate grease fittings more often.

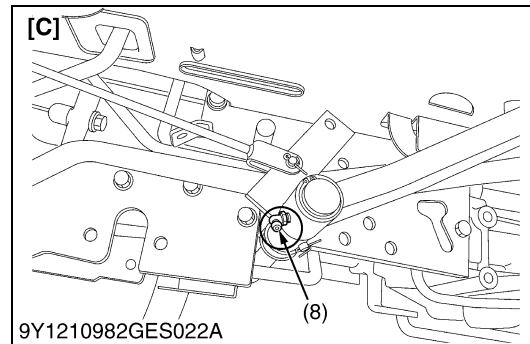
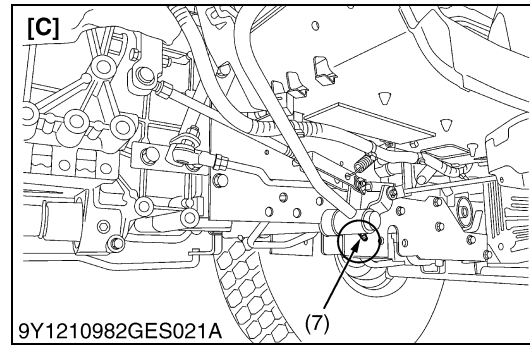

- | | |
|--|------------------------------|
| (1) Grease Fitting (Parking Brake) | [A] All Type |
| (2) Grease Fitting (Top Link) | [B] HST Type |
| (3) Grease Fitting (Lifting Rod, Right) | [C] Manual Transmission Type |
| (4) Battery Terminals | |
| (5) Grease Fitting (Speed Control Pedal) | |
| (6) Grease Fitting (Brake Pedal) | |
| (7) Grease Fitting (Clutch Pedal) | |
| (8) Grease Fitting (Brake Pedal) | |

9Y1210982GEG0024US0

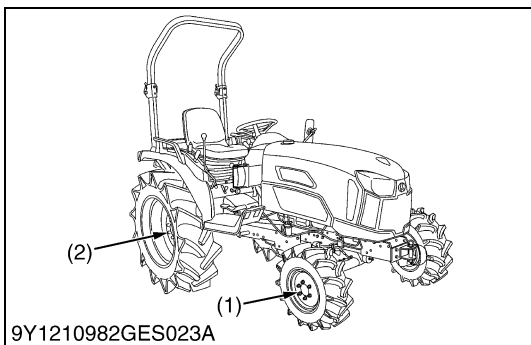

Checking Wheel Mounting Nuts Tightening Torque

⚠ WARNING

To avoid personal injury or death:

- Never operate tractor with a loose rim, wheel or axle.
 - Any time bolts and nuts are loosened, retighten to specified torque.
 - Check all bolts and nuts frequently and keep them tight.
1. Check wheel bolts and nuts regularly especially when new. If they are loose, tighten them as follows.

Tightening torque	Front wheel mounting nut		77 to 90 N·m 7.9 to 9.2 kgf·m 58 to 66 lbf·ft
	Rear wheel mounting nut and screw	B2050 B2350 B2650	108 to 126 N·m 11.1 to 12.8 kgf·m 79.7 to 92.9 lbf·ft
	Rear wheel mounting nut	B3150	167 to 191 N·m 17 to 19.5 kgf·m 123 to 141 lbf·ft
	Rear wheel mounting screw		196 to 225 N·m 20 to 23 kgf·m 145 to 166 lbf·ft

(1) Front Wheel Mounting Nut

(2) Rear Wheel Mounting Nut and Bolt

9Y1210982GEG0025US0

[3] CHECK POINTS OF EVERY 100 HOURS

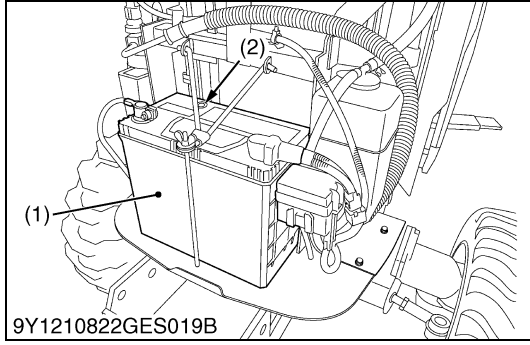

Checking Battery Condition

⚠ DANGER

To avoid the possibility of battery explosion:

For the refillable type battery, follow the instructions below.

- Do not use or charge the refillable type battery if the fluid level is below the LOWER (lower limit level) mark. Otherwise, the battery component parts may prematurely deteriorate, which may shorten the battery's service life or cause an explosion. Check the fluid level regularly and add distilled water as required so that the fluid level is between the UPPER and LOWER levels.

⚠ WARNING

To avoid personal injury or death:

- Never remove the battery cap while the engine is running.
- Keep electrolyte away from eyes, hands and clothes. If you are spattered with it, wash it away completely with water immediately and get medical attention.
- Keep open sparks and flames away from the battery at all times. Hydrogen gas mixed with oxygen becomes very explosive.
- Wear eye protection and rubber gloves when working around battery.

The factory-installed battery is of non-refillable type. If the indicator turns white, do not charge the battery but replace it with new one.

1. Mishandling the battery shortens the service life and adds to maintenance costs.
2. The original battery is maintenance free, but needs some servicing.
3. If the battery is weak, the engine will be difficult to start and the lights will be dim. It is important to check the battery periodically.

■ How to read the indicator

Check the battery condition by reading the indicator.

State of indicator display	
Green	Specific gravity of electrolyte and quality of electrolyte are both in good condition.
Black	Needs charging battery.
White	Needs replacing battery.

(1) Battery

(2) Indicator

9Y1210982GEG0026US0

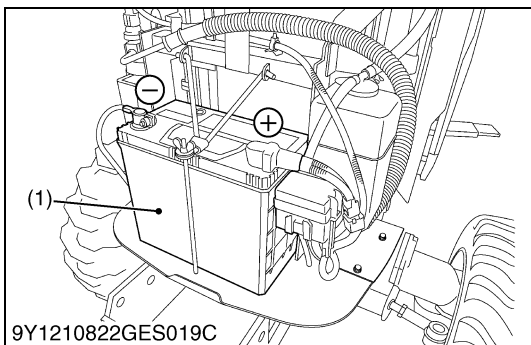

Battery Charging

⚠ WARNING

To avoid personal injury or death:

- When the battery is being activated, hydrogen and oxygen gases in the battery are extremely explosive. Keep open sparks and flames away from the battery at all times, especially when charging the battery.
- When charging the battery, ensure the vent caps are securely in place. (if equipped)
- When disconnecting the cable from the battery, start with the negative terminal first.
When connecting the cable to the battery, start with the positive terminal first.
- Never check battery charge by placing a metal object across the posts.
Use a voltmeter or hydrometer.

1. To slow charge the battery, connect the battery positive terminal to the charger positive terminal and the negative to the negative, then recharge in the standard fashion.
2. A boost charge is only for emergencies. It will partially charge the battery at a high rate and in a short time.
When using a boost-charged battery, it is necessary to recharge the battery as early as possible.
Failure to do this will shorten the battery's service life.
3. The battery is charged if the indicator display turns green from black.
4. When exchanging an old battery into new one, use battery of equal specification shown in table 1.

Table 1

Battery Type	Volt (V)	Capacity at 5 H.R.	Reserve at (min.)	Cold Cranking Amps (A)	Normal Charging Rate (A)
55B24L (S)-MF	12	36	80	SAE : 430 EN : 360	4.5

■ Direction for Storage

1. When storing the tractor for long periods of time, remove the battery from tractor, adjust the electrolyte to the proper level and store in a dry place out of direct sunlight.
2. The battery self-discharges while it is stored.
Recharge it once every three months in hot seasons and once every six months in cold seasons.

(1) Battery

9Y1210982GEG0027US0

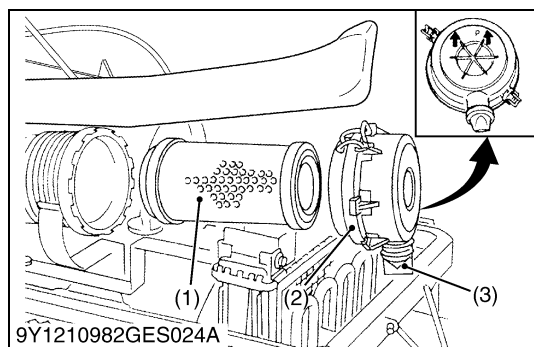

Cleaning Air Cleaner Element [Single Element Type]

1. Remove the element.
2. Clean the element:
 - a) When dry dust adheres to the element, blow compressed air from the inside, turning the element. Pressure of compressed air must be under 205 kPa (2.1 kgf/cm², 30 psi).
 - b) When carbon or oil adheres to the element, soak the element in detergent for 15 minutes then wash it several times in water, rinse with clean water and dry it naturally. After element is fully dried, inspect inside of the element with a light and check if it is damaged or not. (referring to the instructions on the label attached to the case.)
3. Replace air cleaner element:
Once yearly or after every sixth cleaning, whichever comes first.

■ NOTE

- Check to see if the evacuator valve is blocked with dust.

■ IMPORTANT

- The air cleaner uses a dry element, never apply oil.
- Do not run the engine with filter element removed.
- Be sure to refit the cover with the arrow ↑ (on the rear) upright. If the cover is improperly fitted, dust passed by the baffle and directly adheres to the element.

■ Evacuator Valve

Open the evacuator valve once a week under ordinary conditions - or daily when used in a dusty place - to get rid of large particles of dust and dirt.

(1) Elements

(3) Evacuator Valve

(2) Cover

9Y1210982GEG0028US0

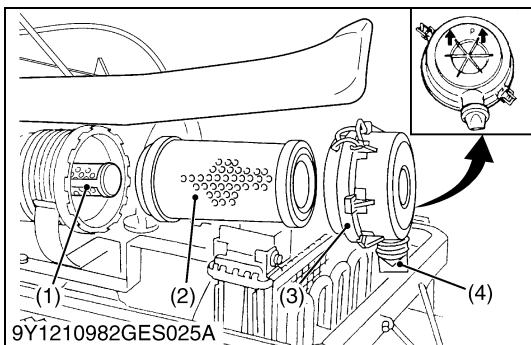

Cleaning Air Cleaner Primary Element [Double Element Type]

1. Remove the air cleaner cover and primary element.
2. Clean the primary element:
 - a) When dry dust adheres to the element, blow compressed air from the inside, turning the element. Pressure of compressed air must be under 205 kPa (2.1 kgf/cm², 30 psi).
 - b) When carbon or oil adheres to the element, soak the element in detergent for 15 minutes then wash it several times in water, rinse with clean water and dry it naturally. After element is fully dried, inspect inside of the element with a light and check if it is damaged or not.
3. Replace air cleaner primary element:
Once yearly or after every sixth cleaning, whichever comes first.

■ **NOTE**

- Check to see if the evacuator valve is blocked with dust.

■ **IMPORTANT**

- The air cleaner uses a dry element, never apply oil.
- Do not run the engine with filter element removed.
- Be sure to refit the cover with the arrow ↑ (on the cover) upright. If the cover is improperly fitted, evacuator valve will not function and dust will adhere to the element.
- Do not touch the secondary element except in cases where replacing is required.

(See "Replacing Air Cleaner Primary Element and Secondary Element" in "EVERY 1 YEAR".)

■ **Evacuator Valve**

Open the evacuator valve once a week under ordinary conditions - or daily when used in a dusty place - to get rid of large particles of dust and dirt.

- | | |
|--------------------------------|---------------------|
| (1) Secondary (Safety) Element | (3) Cover |
| (2) Primary Element | (4) Evacuator Valve |

9Y1210982GEG0029US0

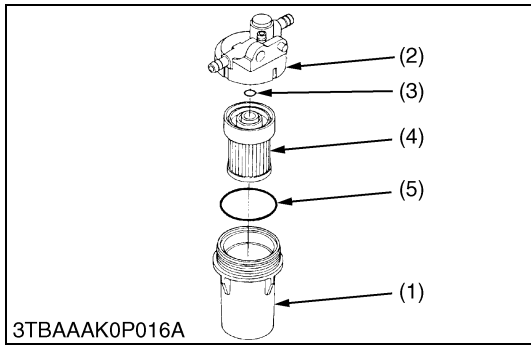
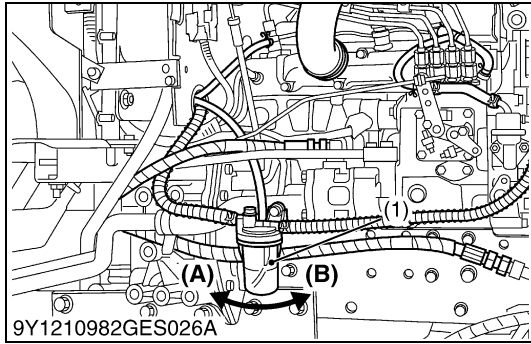

Cleaning Fuel Filter

! WARNING

To avoid personal injury or death:

- Stop the engine and remove the key before checking fuel lines and fuel filter.
- Check the fuel lines periodically. The fuel lines are subject to wear and aging. Fuel may leak out onto the running engine, causing a fire.
- Protect your hands when using kerosene to clean components.

This job should not be done in the field, but in a clean place.

1. Loosen and remove the filter bowl, and rinse the inside with kerosene.
2. Take out the element and dip it in the kerosene to rinse.
3. After cleaning, reassemble the fuel filter, keeping out dust and dirt.
4. Bleed the fuel system. (See "SERVICE AS REQUIRED".)

■ IMPORTANT

- When the fuel filter bowl has been removed, fuel stops flowing from the fuel tank. If the fuel tank is almost full, however, the fuel will flow back from the fuel return pipe to the fuel filter. Before checking, make sure the fuel tank is less than half-full.
- If dust, dirt or water enters the fuel system, the fuel pump and injection nozzles are subject to premature wear. To prevent this, be sure to clean the fuel filter bowl and element periodically.

- | | |
|----------------------|-------------|
| (1) Fuel Filter Bowl | (A) Loosen |
| (2) Filter Bracket | (B) Tighten |
| (3) O-ring | |
| (4) Filter Element | |
| (5) O-ring | |

9Y1210982GEG0030US0

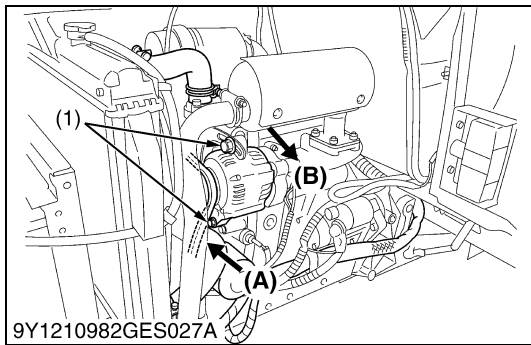

Adjusting Fan Belt Tension

! WARNING

To avoid personal injury or death:

- Be sure to stop engine before checking belt tension.
1. Stop the engine and remove the key.
 2. Apply moderate thumb pressure to belt between pulleys.
 3. If tension is incorrect, loosen the alternator mounting bolts and, using a lever placed between the alternator and the engine block, pull the alternator out until the deflection of the belt falls within acceptable limits.
 4. Replace fan belt if it is damaged.

Fan belt tension	Factory specification	A deflection of between 7.0 to 9.0 mm (0.28 to 0.35 in.) when the belt is pressed in the middle of the span.
------------------	-----------------------	--

- | | |
|----------|----------------------------|
| (1) Bolt | (A) Check the belt tension |
| | (B) To Tighten |

9Y1210982GEG0031US0

Adjusting Brake Pedal

⚠ WARNING

To avoid personal injury or death:

- Stop the engine and chock the wheels before checking brake pedal.
- Be sure that the difference is 5 mm (0.2 in.) or less, when the right and left brake pedals are depressed. If the difference is large, the brake pull to one side when braking, and cause an accident.

1. Slightly depress the right and left brake pedals and measure free travel at the top of pedal stroke.
2. If adjustment is needed, turn the lock nut and adjust nut, adjust free travel.
3. Retighten the lock nut.
4. Check to see that the difference is 5mm or less, when the right and left brake pedals are depressed.

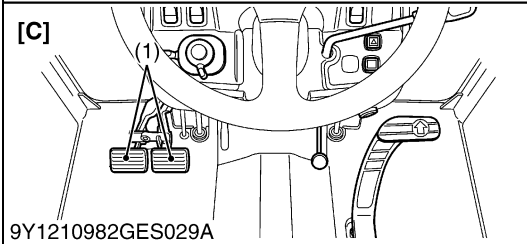
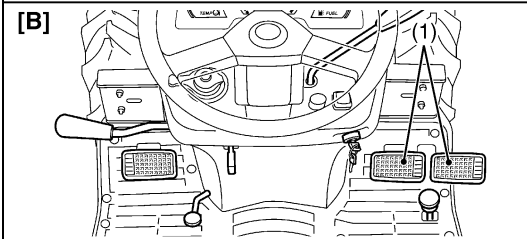
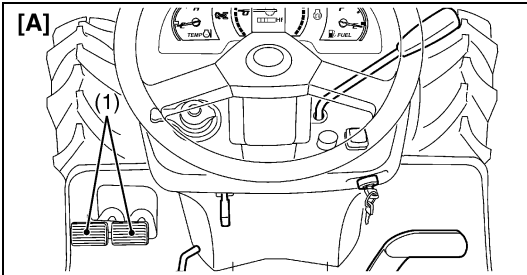
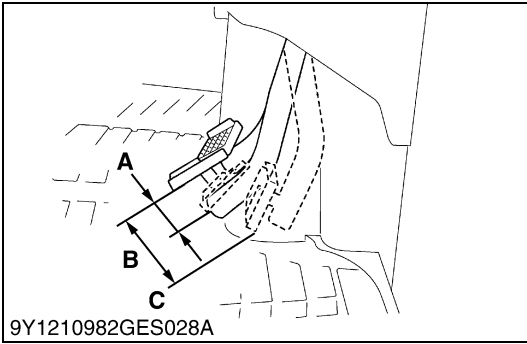

Proper brake pedal free travel	ROPS: 30 to 40 mm (1.2 to 1.5 in.) on the pedal
	CAB: 20 to 30 mm (0.79 to 1.1 in.) on the pedal
Keep the free travel in the right and left brake pedals equal.	

- (1) Brake Pedal
- (2) Brake Lever (Both Sides)
- (3) Adjust Nut (Both Sides)
- (4) Lock Nut (Both Sides)

- [A] ROPS HST Type
- [B] ROPS Manual Transmission Type
- [C] CAB HST Type
- A: Free travel
- B: Pedal stroke
- C: Deference of the right and left pedals is 5mm or less at position

9Y1210982GEG0032US0

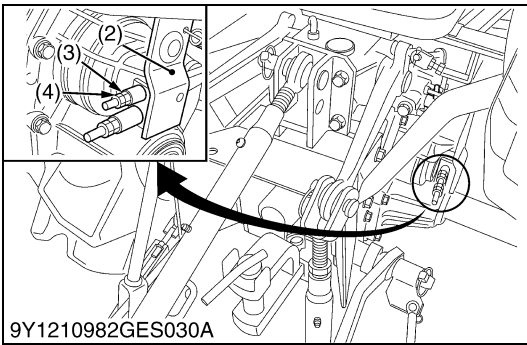

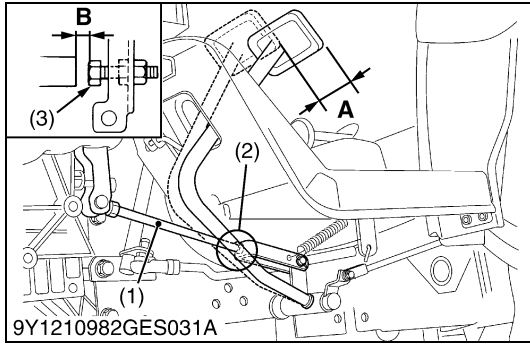

Adjusting Clutch Pedal [ROPS Manual Transmission Type]

1. Stop the engine and remove the key.
2. Slightly depress the clutch pedal and measure free travel at the top of pedal stroke.
3. If adjustment is needed, loosen the lock nut and turn the clutch rod to adjust the rod length within acceptable limits.
4. Retighten the lock nut.
5. After adjusting, release the clutch pedal and check the clearance (B). If adjustment is needed, adjust the clearance (B) with bolt (3).

Proper clutch pedal free travel	10 to 17 mm (0.40 to 0.66 in.) on the pedal
---------------------------------	---

- | | |
|----------------|-----------------------------|
| (1) Clutch Rod | A: Free travel |
| (2) Lock Nut | B: 8.5 mm (0.33 in.) |
| (3) Bolt | |

9Y1210982GEG0033US0

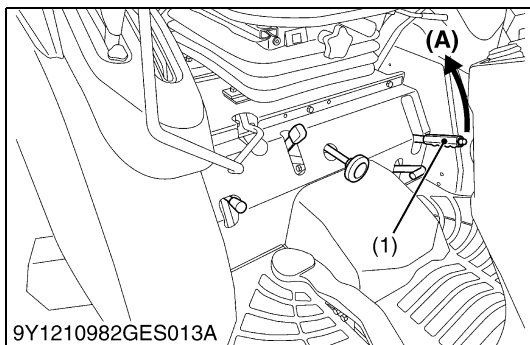

Checking Parking Brake Lever

1. Please raise the lever to the parking position while counting the ratchet sound made by the parking brake lever.

Proper parking brake lever free travel	2 notches (Ratchet sound 2)
--	-----------------------------

- | | |
|-------------------------|-------------------|
| (1) Parking Brake Lever | (A) "PULL" |
|-------------------------|-------------------|

9Y1210982GEG0034US0

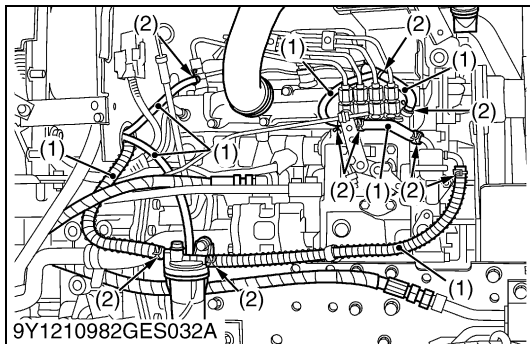

Checking Fuel Line

1. Check to see that all line and hose clamps are tight and not damaged.
2. If hoses and clamps are found worn or damaged, replace or repair them at once.

■ **NOTE**

- If the fuel line is removed, be sure to properly bleed the fuel system.

- | | |
|----------------|-----------------|
| (1) Fuel Hoses | (2) Hose Clamps |
|----------------|-----------------|

9Y1210982GEG0035US0

[4] CHECK POINTS OF EVERY 200 HOURS

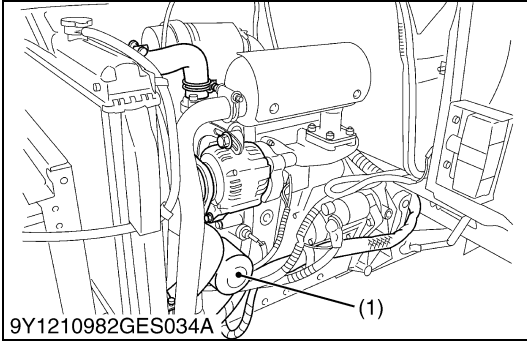

Replacing Engine Oil Filter

⚠ WARNING

To avoid personal injury or death:

- Be sure to stop the engine before changing the oil filter cartridge.
- Allow engine to cool down sufficiently, oil can be hot and can burn.

1. Remove the oil filter.
2. Put a film of clean engine oil on the rubber seal of the new filter.
3. Tighten the filter quickly until it contacts the mounting surface. Tighten filter by hand an additional 1/2 turn only.
4. After the new filter has been replaced, the engine oil normally decreases a little. Make sure that the engine oil does not leak through the seal and be sure to check the oil level on the dipstick. Then, replenish the engine oil up to the prescribed level.

■ IMPORTANT

- To prevent serious damage to the engine, use only a KUBOTA genuine filter.

(1) Engine Oil Filter

9Y1210982GEG0036US0

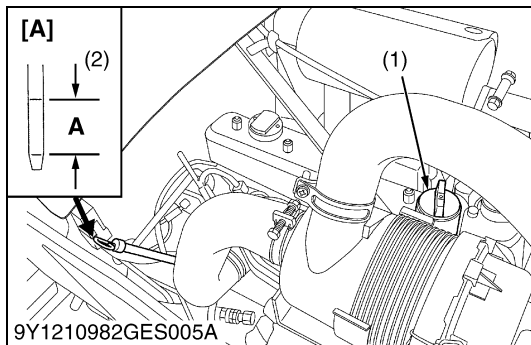

Changing Engine Oil

⚠ WARNING

To avoid personal injury or death:

- Be sure to stop the engine before changing the oil.
- Allow engine to cool down sufficiently, oil can be hot and can burn.

1. To drain the used oil, remove the drain plug at the bottom of the engine and drain the oil completely into the oil pan. All the used oil can be drained out easily when the engine is still warm.
2. After draining reinstall the drain plug.
3. Fill with the new oil up to the upper notch on the dipstick.

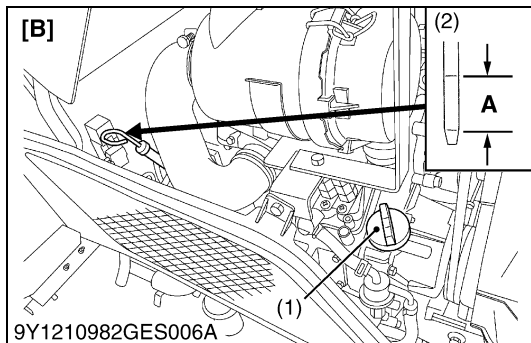

Oil capacity with filter	B2050 B2350	3.1 L 3.3 U.S.qts 2.7 Imp.qts
	B2650 B3150	4.0 L 4.2 U.S.qts 3.5 Imp.qts

- (1) Oil Inlet
 (2) Dipstick
 (3) Drain Plug (Both Sides)

[A] B2050, B2350, B3150

[B] B2650

A: Oil level is acceptable within this range

9Y1210982GEG0037US0

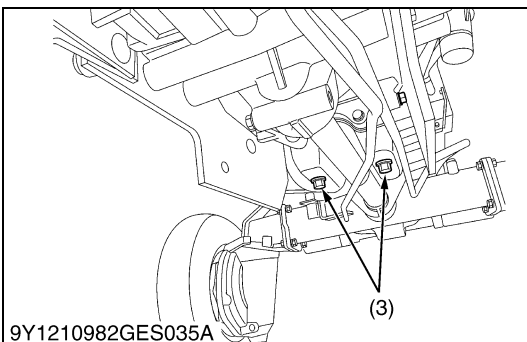

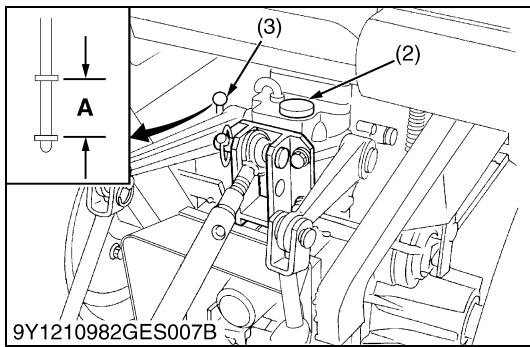
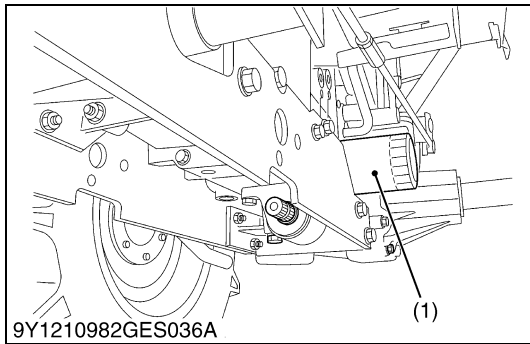

Replacing Transmission Oil Filter [HST]

! WARNING

To avoid personal injury or death:

- Be sure to stop the engine before changing the oil filter cartridge.
- Allow engine to cool down sufficiently, oil can be hot and can burn.

1. Place the oil pan underneath the transmission oil filter and remove the filter.
Do not remove the hydraulic oil filter. Otherwise, the oil comes out.
2. Put a film of clean transmission oil on the rubber seal of the new filter.
3. Quickly tighten the filter until it contacts the mounting surface, then, with a filter wrench, tighten it an additional 1 turn only.
4. After the new filter has been replaced, fill the transmission oil up to the upper limit on the dipstick.
5. After running the engine for a few minutes, stop the engine and check the oil level again, add oil to the prescribed level.
6. Make sure that the transmission fluid doesn't leak past the seal on the filter.

■ IMPORTANT

- To prevent serious damage to the hydraulic system, use only a KUBOTA genuine filter.
- Do not operate the tractor immediately after changing the transmission fluid.

Run the engine at medium speed for a few minutes to prevent damage to the transmission.

- (1) Transmission Oil Filter [HST]
 (2) Oil Inlet
 (3) Dipstick

A: Oil level is acceptable within this range

9Y1210982GEG0038US0

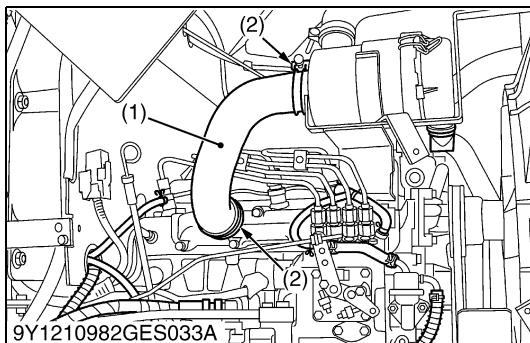

Checking Intake Air Line

1. Check to see that hoses and hose clamps are tight and not damaged.
2. If hoses and clamps are found worn or damaged, replace or repair them at once.

- (1) Hose

- (2) Hose Clamp

9Y1210982GEG0039US0

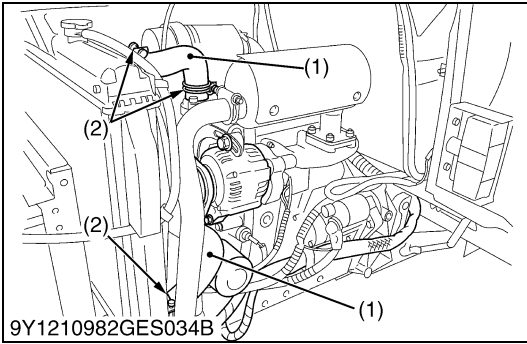

Checking Radiator Hose and Hose Clamp

Check to see if radiator hoses are properly fixed every 200 hours of operation or six months, whichever comes first.

1. If hose clamps are loose or water leaks, tighten bands securely.
2. Replace hoses and tighten hose clamps securely, if radiator hoses are swollen, hardened or cracked. Replace hoses and hose clamps every 2 years or earlier if checked and found that hoses are swollen, hardened or cracked.

■ Precaution at Overheating

Take the following actions in the event the coolant temperature is nearly or more than the boiling point, what is called "Overheating".

1. Stop the machine operation in a safe place and keep the engine unloaded idling.
2. Don't stop the engine suddenly, but stop it after about 5 minutes of unloaded idling.
3. Keep yourself well away from the machine for further 10 minutes or while the steam blown out.
4. Checking that there gets on danger such as burn, get rid of the causes of overheating according to the manual, see "Troubleshooting" section, and then, start again the engine.

- (1) Radiator Hose (2 Hoses) (2) Clamp (4 Clamps)

9Y1210982GEG0040US0

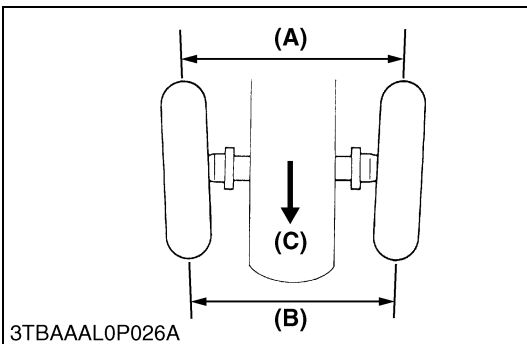

Adjusting Toe-in

1. Park tractor on a flat place.
2. Turn steering wheel so front wheels are in the straight ahead position.
3. Lower the implement, lock the park brake and stop the engine.
4. Measure distance between tire beads at front of tire, hub height.
5. Measure distance between tire beads at rear of tire, hub height.
6. Front distance should be 0 to 10 mm (0 to 0.39in.) less than rear distance. If not, adjust tie-rod length.

■ Adjusting procedures

1. Loosen the tie-rod nut.
2. Turn the tie-rod to adjust the rod length until the proper toe-in measurement is obtained.
3. Retighten the tie-rod nut.

- (1) Tie-rod Nut
(2) Tie-rod

- (A) Wheel-to-wheel distance at rear
(B) Wheel-to-wheel distance at front
(C) "FRONT"

9Y1210982GEG0041US0

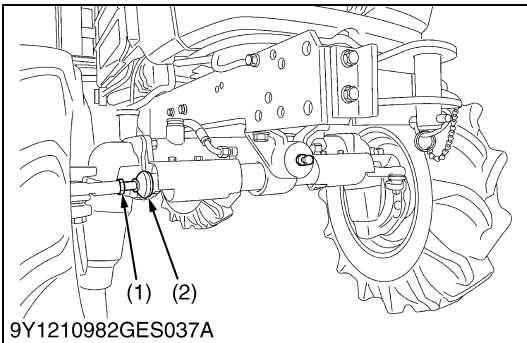

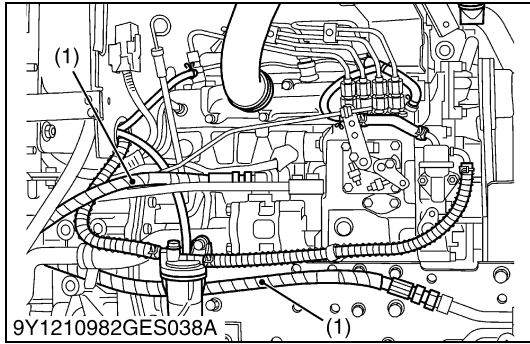

Checking Power Steering Line

1. Check to see that all lines and hose clamps are tight and not damaged.
2. If hoses and clamps are found worn or damaged, replace or repair them at once.

(1) Power Steering Pressure Hoses

9Y1210982GEG0042US0

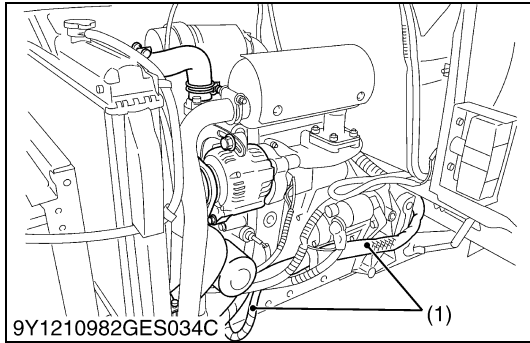

Adjusting Air Conditioner Belt Tension

! WARNING

To avoid personal injury or death:

- Be sure to stop the engine and remove the key before checking.

1. Stop the engine and remove the key.
2. Apply moderate thumb pressure to belt between pulleys.
3. If tension is incorrect, loosen the tension pulley mounting nut and turn the adjusting bolt to adjust the belt tension within acceptable limits.
4. Replace air-conditioner belt if it is damaged.

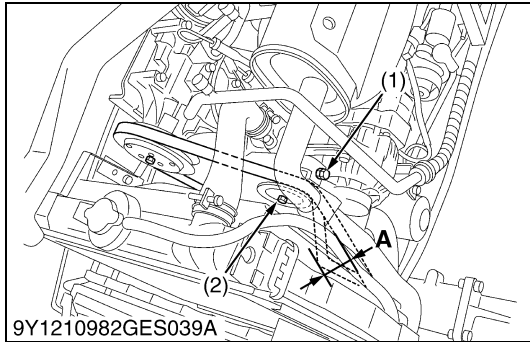

Air conditioner belt tension	Factory specification	A deflection of between 10 to 12 mm (0.39 to 0.47 in.) when the belt is pressed in the middle of the span
------------------------------	-----------------------	---

(1) Adjusting Bolt
(2) Nut

L: Deflection

9Y1210982GEG0043US0

Cleaning Inner Air Filter [CABIN HST Type]

1. Press the inner air filter and blow air from the direction opposite to the filter's normal air flow.
2. Pressure of compressed air must be under 205 kPa (2.1 kgf/cm², 30 psi).

(1) Inner Air Filter

(2) Screw

9Y1210982GEG0044US0

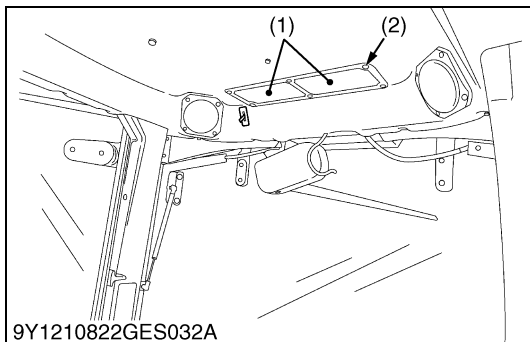

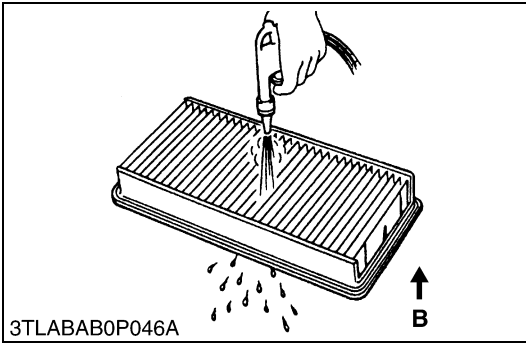
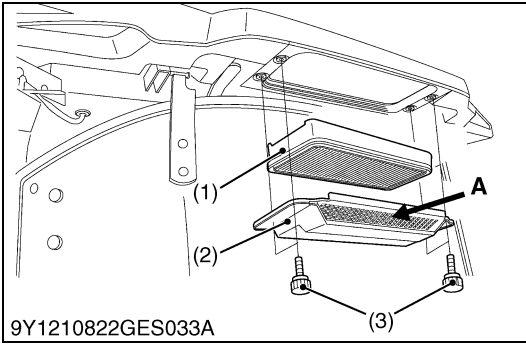

Cleaning Air Filter [CABIN HST Type]

■ **Fresh Air Filter**

1. Remove the knob bolts (3) and pull out the fresh air filter (1).
2. Blow air from the opposite direction to the filter's normal air flow. Pressure of compressed air must be under 205 kPa (2.1 kgf/cm², 30 psi).

■ **NOTE**

- Attach the filter and cover as illustration.
- If the filter is very dirty:
Dip the filter in lukewarm water with mild dish washing detergent. Move it up and down as well as left and right to loosen dirt. Rinse the filter with clean water and let it air-dry.

■ **IMPORTANT**

- Do not use gasoline, thinner or similar chemicals to clean the filter as damage to the filter may occur.
- It may also cause an unpleasant odor in the CABIN when the system is used next.
- Do not hit the filter. If the filter becomes deformed, dust may enter into the air-conditioner, which may cause damage and malfunction.

- (1) Fresh Air Filter
- (2) Cover
- (3) Knob Bolt

- A: Air Inlet Port
- B: Air Conditioner Air Flow

9Y1210982GEG0045US0

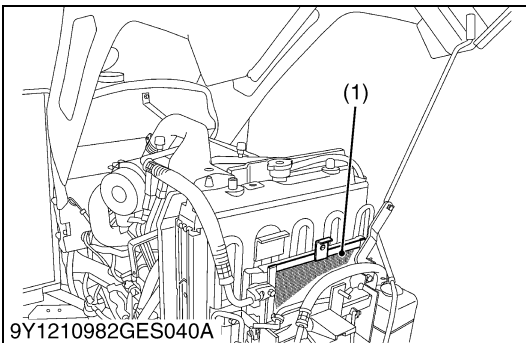

Checking Air Conditioner Condenser [CABIN HST Type]

⚠ WARNING

To avoid personal injury or death:

- Be sure to stop the engine before removing the screen.
 - The condenser and receiver become hot while the air conditioner is running. Before checking or cleaning them, wait long enough until they cool down.
1. Check the air conditioner condenser (1) to be sure that it is clean of debris.

- (1) Air Conditioner Condenser

9Y1210982GEG0046US0

[5] CHECK POINTS OF EVERY 400 HOURS

Changing Transmission Fluid

WARNING

To avoid personal injury or death:

- Allow engine to cool down sufficiently, oil can be hot and can burn.
1. To drain the used oil, remove the drain plug at the bottom of the transmission case and drain the oil completely into the oil pan.
 2. After draining reinstall the drain plug.
 3. Fill with new KUBOTA SUPER UDT fluid up to the upper notch on the dipstick.
 4. After running the engine for a few minutes, stop it and check the oil level again; add oil to prescribed level.
 5. Properly dispose of used oil.

Oil capacity	B2050 B2350 B2650	Manual Transmission	16.5 L 4.36 U.S.gals 3.63 Imp.gals
		HST	17 L 4.49 U.S.gals 3.74 Imp.gals
	B3150	HST	17 L 4.49 U.S.gals 3.74 Imp.gals

■ IMPORTANT

- If the 3-point hitch can not be raised by setting the hydraulic control lever to the UP position after long term storage or when changing the transmission oil, turn steering wheel to the right and left several times to bleed air from the system.
- Do not operate the tractor immediately after changing the transmission fluid.

- (1) Oil Inlet
- (2) Dipstick
- (3) Drain Plug
- (4) Drain Plug (Both Sides)

A: Oil level is acceptable within this range
[A] Without Mid-PTO

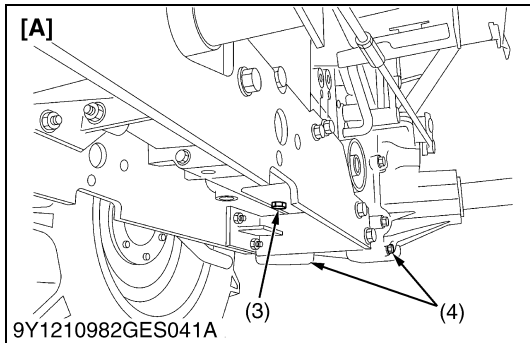
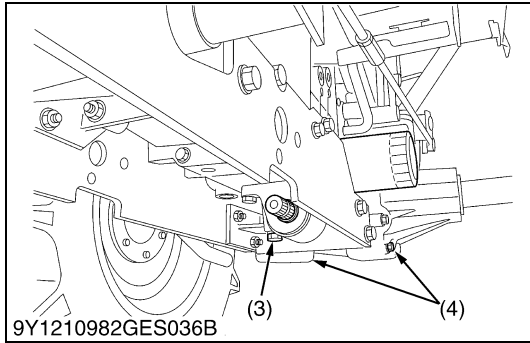
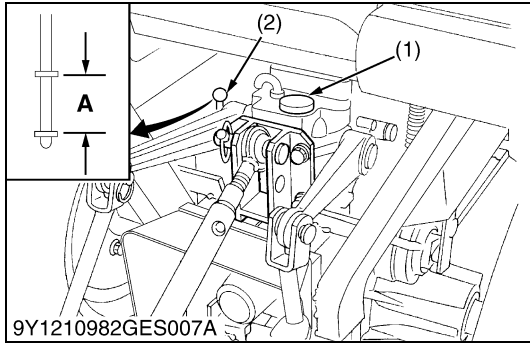

9Y1210982GEG0047US0

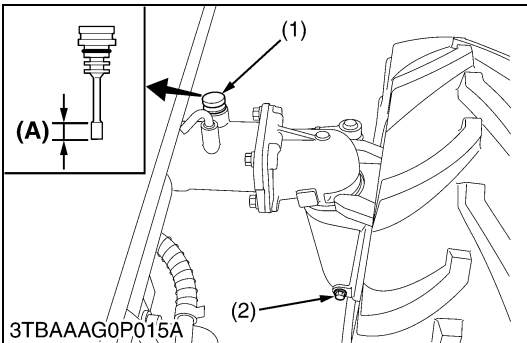
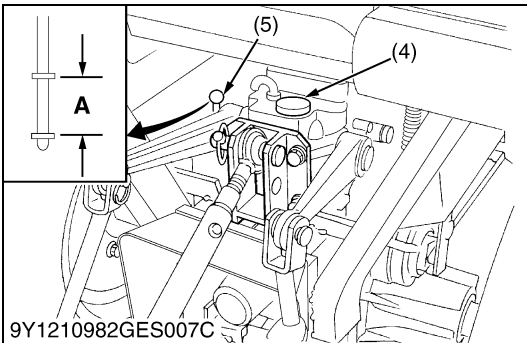
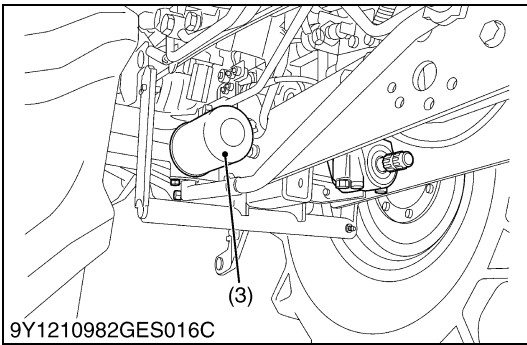
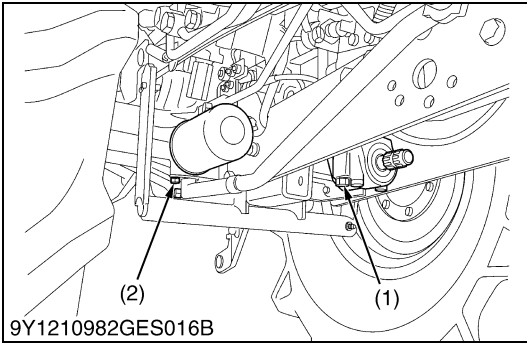

Replacing Hydraulic Oil Filter

⚠ WARNING

To avoid personal injury or death:

- Be sure to stop the engine before changing the oil filter cartridge.
- Allow engine to cool down sufficiently, oil can be hot and can burn.

1. Remove the drain plugs at the bottom of the transmission case and drain the oil completely into the oil pan.
2. After draining reinstall the drain plugs.
3. Remove the oil filter.
4. Put a film of clean transmission oil on the rubber seal of the new filter.
5. Quickly tighten the filter until it contacts the mounting surface, then tighten it by hand an additional 1/2 turn only.
6. After the new filters have been replaced, fill the transmission oil up to the upper notch on the dipstick.
7. After running the engine for a few minutes, stop the engine and check the oil level again, add oil to the prescribed level.
8. Make sure that the transmission fluid does not leak past the seal on the filter.

■ IMPORTANT

- To prevent serious damage to the hydraulic system, use only a KUBOTA genuine filter.

- (1) Drain Plug
- (2) Drain Plug (Both Sides)
- (3) Transmission Oil Filter
- (4) Oil Inlet
- (5) Dipstick

A: Oil level is acceptable within this range.

9Y1210982GEG0048US0

Changing Front Axle Case Oil

1. Park the tractor on a firm, flat and level surface.
2. To drain the used oil, remove the right and left drain plugs and filling plug at the front axle case and drain the oil completely into the oil pan.
3. After draining, reinstall the drain plugs.
4. Fill with new oil up to the upper notch on the dipstick.

■ IMPORTANT

- After ten minutes, check the oil level again; add oil to prescribed level.
5. After filling, reinstall the filling plug.
 6. Properly dispose of used oil.

Oil capacity	B2050	3.7 L
	B2350	3.9 U.S.qts
	B2650	3.3 Imp.qts
	B3150	4.7 L
		5.0 U.S.qts
		4.1 Imp.qts

- (1) Filling Plug with Dipstick
- (2) Drain Plug

(A) Oil level is acceptable within this range.

9Y1210982GEG0049US0

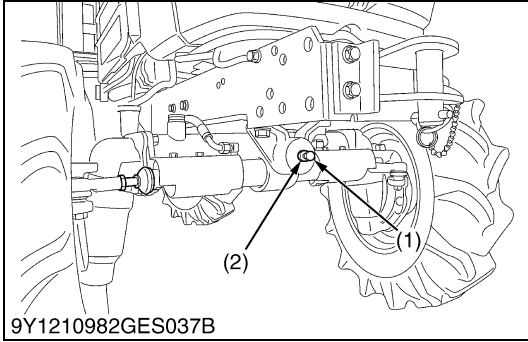

Adjusting Front Axle Pivot [4WD]

1. If the front axle pivot pin adjustment is not correct, front wheel vibration can occur causing vibration in the steering wheel.

■ **Adjusting procedure**

1. Loosen the lock nut, and tighten the adjusting screw so that the oscillating load is 50 to 100 N (5.1 to 10.2 kgf, 11.2 to 22.5 lbf). (If the adjusting screw is tightened, loosened and retightened, apply liquid gasket to its tip.)
2. Retighten the lock nut.

(1) Adjusting Screw

(2) Lock Nut

9Y1210982GEG0050US0

Replacing Fuel Filter Element

- See page G-26.

9Y1210982GEG0051US0

[6] CHECK POINT OF EVERY 800 HOURS

Adjusting Engine Valve Clearance

- See page 1-S15.

9Y1210982GEG0052US0

[7] CHECK POINT OF EVERY 1500 HOURS

Checking Fuel Injection Nozzle Injection Pressure

- See page 1-S19.

9Y1210982GEG0053US0

[8] CHECK POINT OF EVERY 3000 HOURS

Checking Injection Pump

- See page 1-S20.

9Y1210982GEG0054US0

[9] CHECK POINTS OF EVERY 1 YEAR

Checking Air Cleaner Element

- See page G-25.

9Y1210982GEG0055US0

Replacing Air Cleaner Primary Element and Secondary Element

- See page G-25.

■ **IMPORTANT**

- To prevent serious damage to the engine, use only a KUBOTA genuine filter.

9Y1210982GEG0056US0

Checking the Air Conditioner Pipe and Hose [CABIN]

1. Check to see that all lines and hose clamps are tight and not damaged.
2. If hoses and clamps are found worn or damaged., replace or repair them at once.

9Y1210982GEG0057US0

Checking the CAB Isolation Cushion

1. Check the cushion for any breakage or fatigue. Replace them if they have deteriorated.

9Y1210982GEG0058US0

[10] CHECK POINTS OF EVERY 2 YEARS

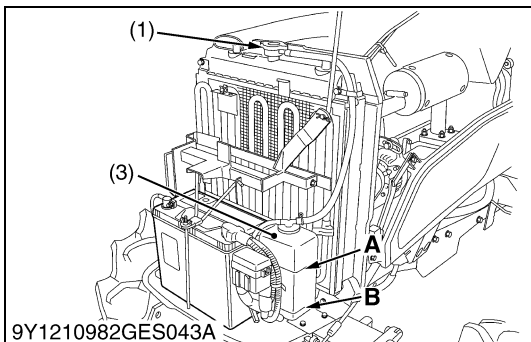
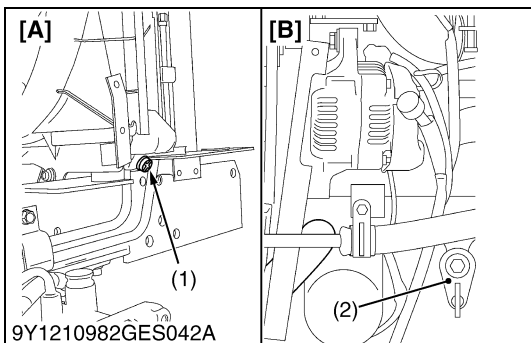

Flushing Cooling System and Changing Coolant

⚠ WARNING

To avoid personal injury or death:

- Do not remove radiator cap while coolant is hot. When cool, slowly rotate cap to the first stop and allow sufficient time for excess pressure to escape before removing the cap completely.
1. Stop the engine, remove the key and let it cool down.
 2. To drain the coolant, open the radiator drain plug and remove the radiator cap. The radiator cap must be removed to completely drain the coolant.
 3. After all coolant is drained, close the drain plug.
 4. Fill with clean water and cooling system cleaner.
 5. Follow directions of the cleaner instruction.
 6. After flushing, fill with clean water and anti-freeze until the coolant level is just below the radiator cap. Install the radiator cap securely.
 7. Fill with coolant up to the "FULL" mark on the recovery tank.
 8. Start and operate the engine for few minutes.
 9. Stop the engine, remove the key and let cool.
 10. Check coolant level of recovery tank and add coolant if necessary.
 11. Properly dispose of used coolant.

■ IMPORTANT

- Do not start engine without coolant.
- Use clean, fresh water and anti-freeze to fill the radiator and recovery tank.
- When the anti-freeze is mixed with water, the anti-freeze mixing ratio must be less than 50 %.
- Securely tighten radiator cap. If the cap is loose or improperly fitted, water may leak out and the engine could overheat.

Coolant capacity (with recover tank)	4.6 L
	4.9 U.S.qts
	4.0 Imp.qts

- | | |
|-------------------|----------------|
| (1) Radiator Cap | A: FULL |
| (2) Drain Plug | B: LOW |
| (3) Recovery Tank | |

(To be continued)

(Continued)

■ Anti-Freeze



WARNING

To avoid personal injury or death:

- When using antifreeze, put on some protection such as rubber gloves (Antifreeze contains poison.).
- If it is swallowed, seek immediate medical help.
Do NOT make a person throw up unless told to do so by poison control or a health care professional. Use standard first aid and CPR for signs of shock or cardiac arrest. Call your local Poison Control Center or your local emergency number for further assistance.
- When antifreeze comes in contact with the skin or clothing, wash it off immediately.
- Do not mix different types of Antifreeze.
The mixture can produce chemical reaction causing harmful substances.
- Antifreeze is extremely flammable and explosive under certain conditions. Keep fire and children away from antifreeze.
- When draining fluids from the engine, place some container underneath the engine body.
- Do not pour waste onto the grounds, down a drain, or into any water source.
- Also, observe the relevant environmental protection regulations when disposing of antifreeze.

Always use a 50/50 mix of long-life coolant and clean soft water in KUBOTA engines.

1. Long-life coolant (hereafter LLC) comes in several types. Use ethylene glycol (EG) type for this engine.
2. Before employing LLC-mixed cooling water, fill the radiator with fresh water and empty it again.
Repeat this procedure 2 or 3 times to clean up the inside.
3. Mixing the LLC
Premix 50 % LLC with 50% clean soft water. When mixing, stir it up well, and then fill into the radiator.
4. The procedure for the mixing of water and antifreeze differs according to the make of the antifreeze and the ambient temperature. Refer to SAE J1034 standard, more specifically also to SAE J814c.

Vol % Anti-freeze	Freezing Point		Boiling Point*	
	°C	°F	°C	°F
50	-37	-34	108	226

*At 1.013×10^5 Pa (760 mmHg) pressure (atmospheric). A higher boiling points is obtained by using a radiator pressure cap which permits the development of pressure within the cooling system.

(To be continued)

(Continued)

5. Adding the LLC
 - a) Add only water if the mixture reduces in amount by evaporation.
 - b) If there is a mixture leak, add the LLC of the same manufacture and type in the same mixture percentage.
 *Never add any long-life coolant of different manufacture. (Different brands may have different additive components, and the engine may fail to perform as specified.
6. When the LLC is mixed, do not employ any radiator cleaning agent. The LLC contains anticorrosive agent. If mixed with the cleaning agent, sludge may build up, adversely affecting the engine parts.
7. Kubota's genuine long-life coolant has a service life of 2 years. Be sure to change the coolant every 2 years.

■ **NOTE**

- The above data represent industry standards that necessitate a minimum glycol content in the concentrated anti-freeze.

9Y1210982GEG0059US0

Replacing Radiator Hoses (Water Pipes)

- See page G-31 and G-37.

9Y1210982GEG0060US0

Replacing Fuel Hoses

- See page G-28.

9Y1210982GEG0061US0

Replacing Intake Air Hoses

- See page G-30.

9Y1210982GEG0062US0

Replacing Power Steering Hose

- See page G-32.

9Y1210982GEG0063US0

Replacing Air Conditioner Hose [CABIN]

- See page 10-M1 and 10-S17.

9Y1210982GEG0064US0

[11] OTHERS

Bleeding Fuel System

Air must be removed:

1. When the fuel filter or lines are removed.
2. When the tank is completely empty.
3. After the tractor has not been used for a long period of time.

Bleeding procedure is as follows.

1. Fill the fuel tank with fuel.
2. Start the engine and run for about 30 seconds, and then stop the engine.

9Y1210982GEG0065US0

Draining Clutch Housing Water

■ **NOTE**

- The tractor is equipped with a water drain plug (1) under the clutch housing.
- After operating in rain, snow or tractor has been washed, water may get into the clutch housing.

1. Remove the drain plug and drain the water, then install the plug again.

(1) Water Drain Plug

9Y1210982GEG0066US0

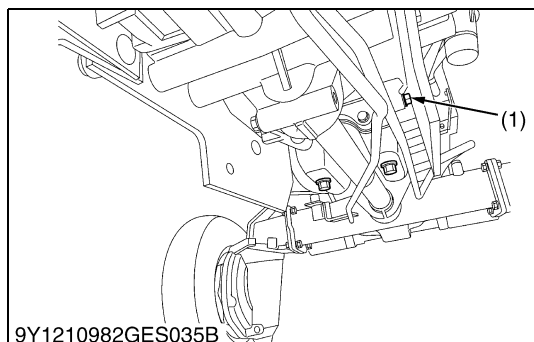

9Y1210982GES035B

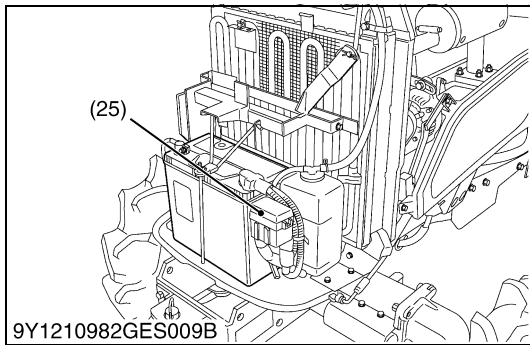
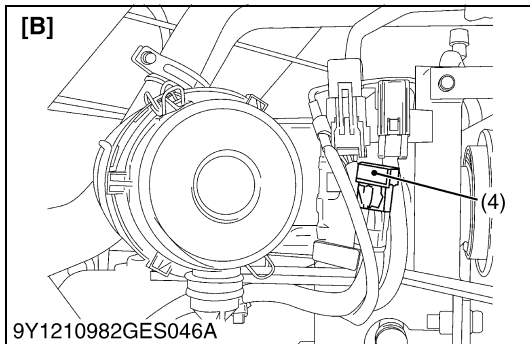
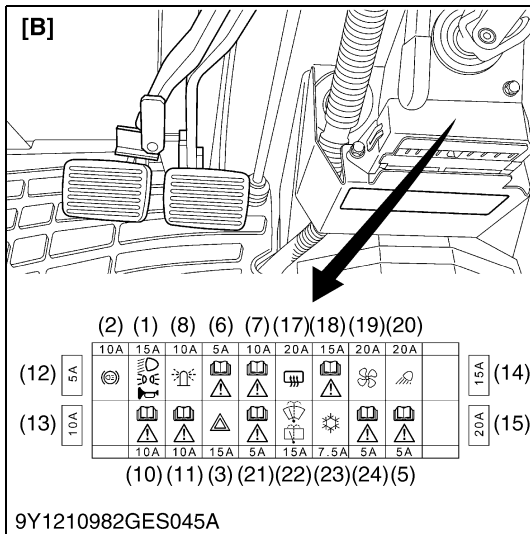
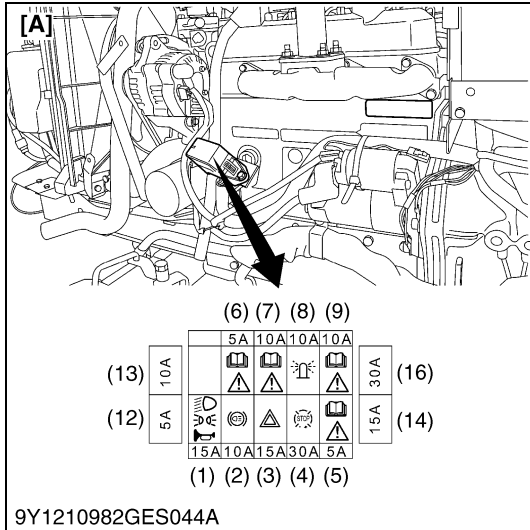

Replacing Fuse

1. The tractor electrical system is protected from potential damage by fuses.
A blown fuse indicates that there is an overload or short somewhere in the electrical system.
2. If any of the fuses should blow, replace with a new one of the same capacity.

IMPORTANT

- Before replacing a blown fuse, determine why the fuse blew and make any necessary repairs. Failure to follow this procedure may result in serious damage to the tractor electrical system.

Protected circuit

Fuse No.	Capacity (A)	Protected circuit	ROPS	ROPS
(1)	15	Head light / Position lamp / Horn	☆	☆
(2)	10	Brake lamp	☆	☆
(3)	15	Flasher / Hazard	☆	☆
(4)	30	Key stop	☆	☆
(5)	5	Glow relay	☆	☆
(6)	5	Panel / OPC	☆	☆
(7)	10	Alternator / ACC relay	☆	☆
(8)	10	Beacon	☆	☆
(9)	10	Outlet	☆	-
(10)	10	Outlet (Rear)	-	☆
(11)	10	Outlet (Front)	-	☆
(12)	5	Spare fuse	☆	☆
(13)	10	Spare fuse	☆	☆
(14)	15	Spare fuse	☆	☆
(15)	20	Spare fuse	-	☆
(16)	30	Spare fuse	☆	-
(17)	20	Defogger	-	☆
(18)	15	Radio / Dome light	-	☆
(19)	20	Aircon blower	-	☆
(20)	20	Work light	-	☆
(21)	5	Panel	-	☆
(22)	15	Wiper	-	☆
(23)	7.5	Aircon	-	☆
(24)	5	Radio	-	☆
(25)	Slow blow fuse	Check circuit against wrong battery connection	☆	☆

[A] ROPS Type

[B] CAB Type

9Y1210982GEG0067US0

Checking Amount of Refrigerant (Gas) [CABIN]

⚠ WARNING

To avoid personal injury:

- Liquid contact with eyes or skin may cause frostbite.
- In the event of a leakage, wear safety goggles. Escaping refrigerant can cause severe injuries to eyes.
- In contact with a flame, R134a refrigerant gives a toxic gas.
- Do not disconnect any part of the refrigeration circuit of the air conditioning system.

A shortage of refrigerant impairs the air-conditioner performance. Check the following points. If it is indicated that the amount of refrigerant is extremely low, inspect and charge.

■ Checking Procedure

1. Run the air-conditioner in the following conditions.
 - Engine speed: About 1500 min⁻¹ (rpm)
 - Temperature control lever: Maximum cooling position (leftmost)
 - Fan switch: Highest blow (HI)
 - Air-conditioner switch: **ON**
2. Look into the sight glass to see if the refrigerant is flowing through its circuit.

■ IMPORTANT

- Charge only with R134a not R12 refrigerant (gas).

(1) Sight Glass

- (A) Proper: Little or no air bubbles in the refrigerant flow.
- (B) Low: Lots of air bubbles in the refrigerant flow (air bubbles or foam passing continuously).
- (C) Overfull or no refrigerant: Colorless and transparent.

9Y1210982GEG0071US0

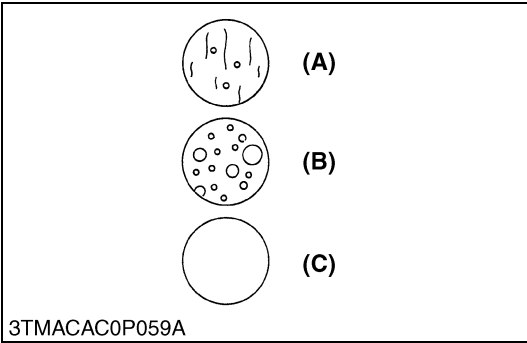
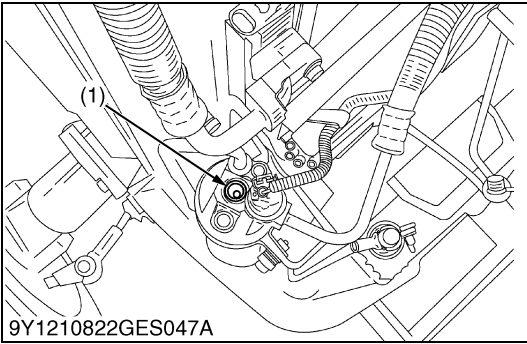

8. SPECIAL TOOLS

[1] SPECIAL TOOLS FOR ENGINE

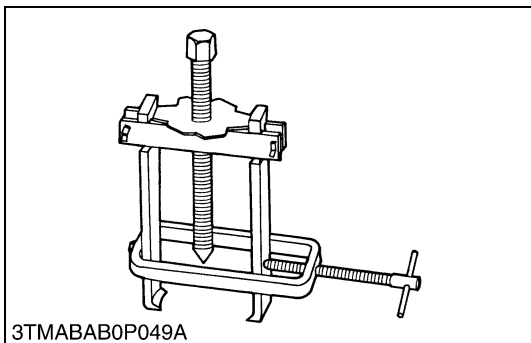

Special Use Puller Set

Code No.

- 07916-09032

Application

- Use exclusively to pull out bearing, gears and other parts with ease.

WSM000001GEG0011US0

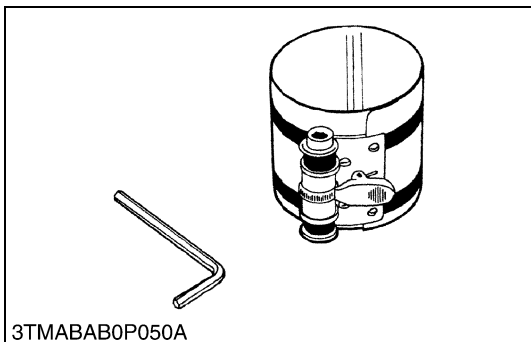

Piston Ring Compressor

Code No.

- 07909-32111

Application

- Use exclusively to push in the piston with piston rings into the cylinder.

WSM000001GEG0012US0

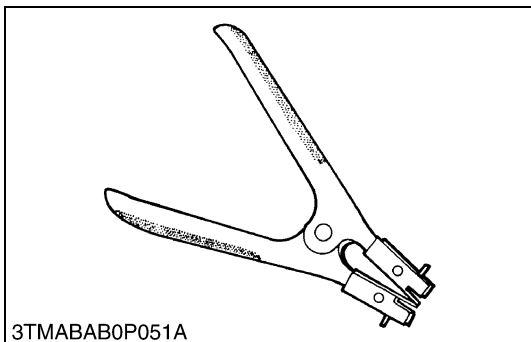

Piston Ring Tool

Code No.

- 07909-32121

Application

- Use exclusively to remove or install the piston ring with ease.

WSM000001GEG0013US0

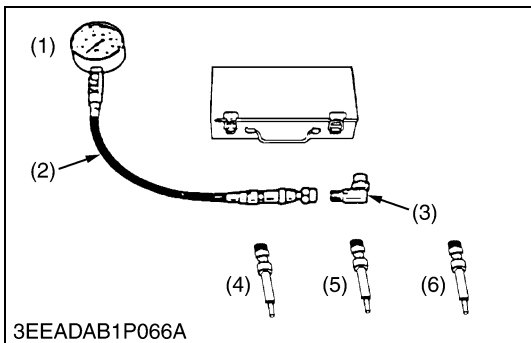

Diesel Engine Compression Tester (for Glow Plug)

Code No.

- 07909-39081 (Assembly)
- 07909-31291 (K)
- 07909-31301 (L)
- 07909-31311 (M)

Application

- Use to measure diesel engine compression and diagnosis of need for major overhaul.

- (1) Gauge
- (2) Hose Assembly
- (3) L Joint

- (4) Adaptor K
- (5) Adaptor L
- (6) Adaptor M

WSM000001GEG0096US0

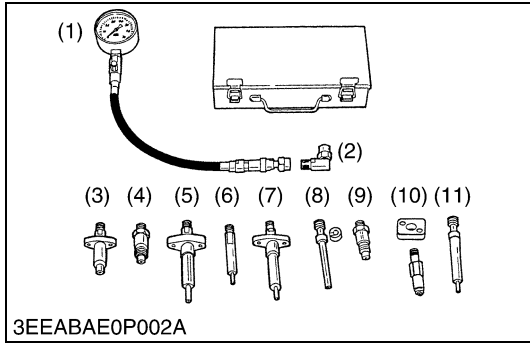

Diesel Engine Compression Tester (for Injection Nozzle)

Code No.

- 07909-30208 (Assembly)
- 07909-30934 (A to F)
- 07909-31211 (E and F)
- 07909-31231 (H)
- 07909-31251 (G)
- 07909-31271 (I)
- 07909-31281 (J)

Application

- Use to measure diesel engine compression and diagnostics of need for major overhaul.

- | | |
|---------------|----------------|
| (1) Gauge | (7) Adaptor F |
| (2) L Joint | (8) Adaptor G |
| (3) Adaptor A | (9) Adaptor H |
| (4) Adaptor B | (10) Adaptor I |
| (5) Adaptor C | (11) Adaptor J |
| (6) Adaptor E | |

WSM000001GEG0014US0

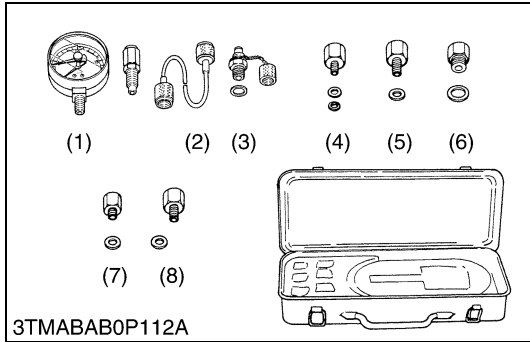

Oil Pressure Tester

Code No.

- 07916-32032

Application

- Use to measure lubricating oil pressure.

- | | |
|--------------------|---------------|
| (1) Gauge | (5) Adaptor 2 |
| (2) Cable | (6) Adaptor 3 |
| (3) Threaded Joint | (7) Adaptor 4 |
| (4) Adaptor 1 | (8) Adaptor 5 |

WSM000001GEG0015US0

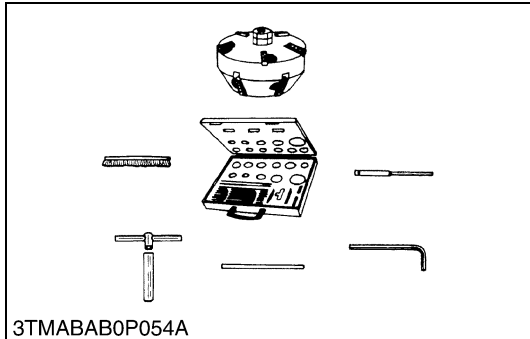

Valve Seat Cutter

Code No.

- 07909-33102

Application

- Use to reseal valves.

Angle

- 0.79 rad (45 °)
- 0.26 rad (15 °)

Diameter

- 28.6 mm (1.13 in.)
- 31.6 mm (1.24 in.)
- 35.0 mm (1.38 in.)
- 38.0 mm (1.50 in.)
- 41.3 mm (1.63 in.)
- 50.8 mm (2.00 in.)

WSM000001GEG0016US0

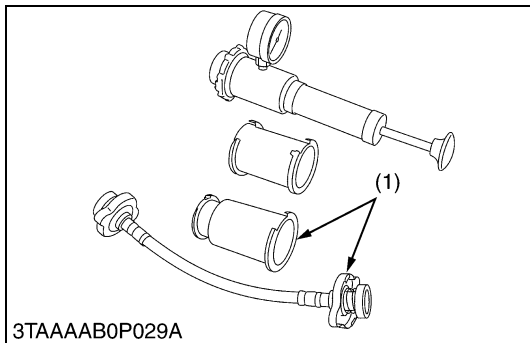

Radiator Tester

Code No.

- 07909-31551

Application

- Use to check of radiator cap pressure, and leaks from cooling system.

Remarks

- Adaptor (1) BANZAI Code No. RCT-2A-30S.

- (1) Adaptor

WSM000001GEG0017US0

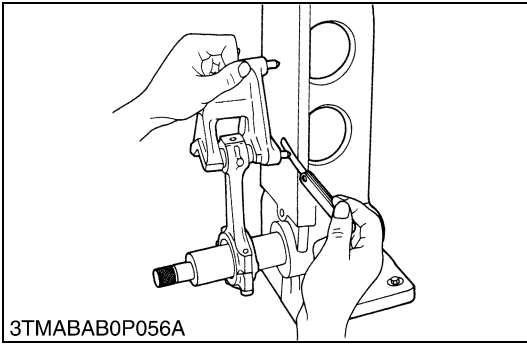

Connecting Rod Alignment Tool

Code No.

- 07909-31661

Application

- Use to check the connecting rod alignment.

Applicable range

- Connecting rod big end I.D.
30 to 75 mm dia. (1.2 to 2.9 in. dia.)
- Connecting rod length
65.0 to 300 mm (2.56 to 11.8 in.)

WSM000001GEG0020US0

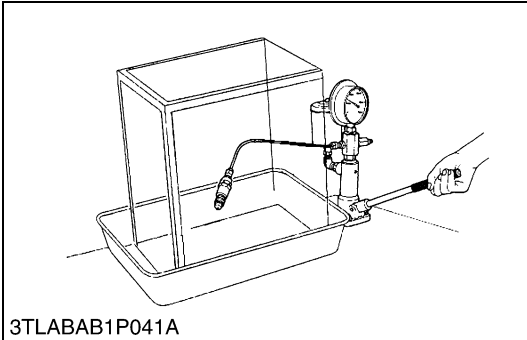

Nozzle Tester

Code No.

- 07909-31361

Application

- Use to check the fuel injection pressure and spray pattern of nozzle.

Measuring range

- 0 to 50 MPa (0 to 500 kgf/cm², 0 to 7200 psi)

WSM000001GEG0021US0

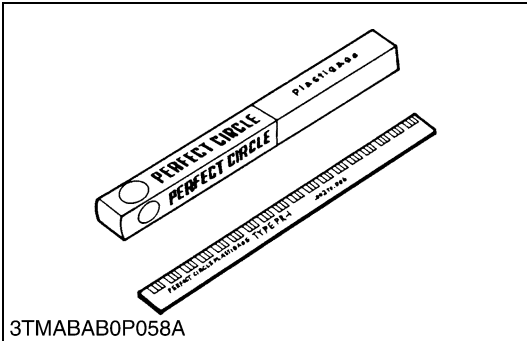

Plastigauge

Code No.

- 07909-30241

Application

- Use to check the oil clearance between crankshaft and bearing, etc..

Measuring range

- Green: 0.03 to 0.07 mm (0.001 to 0.003 in.)
- Red: 0.05 to 0.1 mm (0.002 to 0.006 in.)
- Blue: 0.1 to 0.2 mm (0.004 to 0.009 in.)

WSM000001GEG0022US0

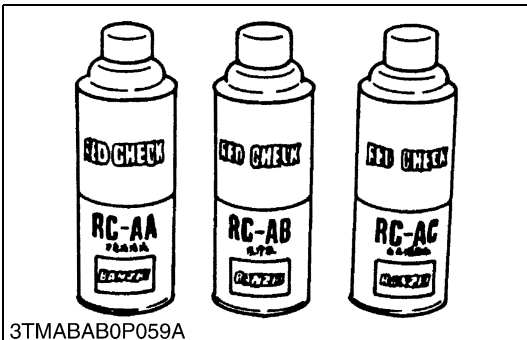

Red Check

Code No.

- 07909-31371

Application

- Use to check cracks on cylinder head, cylinder block, etc..

WSM000001GEG0023US0

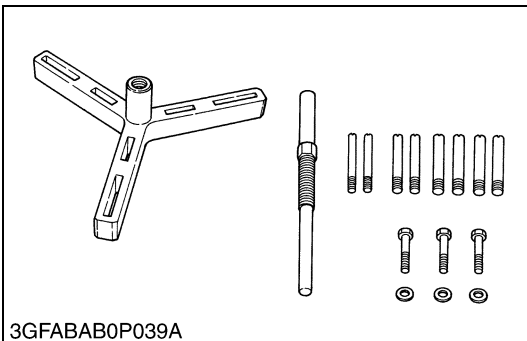

Flywheel Puller

Code No.

- 07916-32011

Application

- Use exclusively to remove the flywheel with ease.

WSM000001GEG0018US0

■ **NOTE**

- The following special tools are not provided, so make them referring to the figure.

WSM000001GEG0026US0

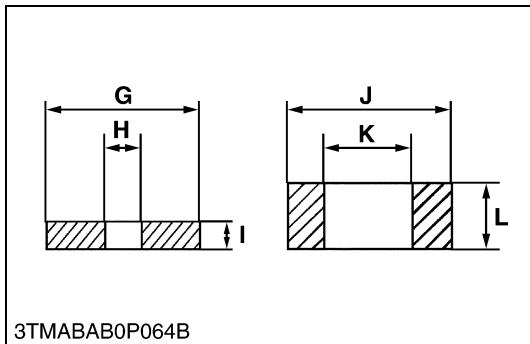
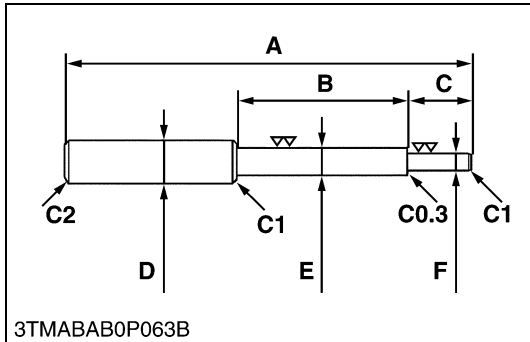

Valve Guide Replacing Tool

Application

- Use to press out and press fit the valve guide.

■ **NOTE**

- The following special tools are not provided, so make them referring to the figure.

A	225 mm (8.86 in.)
B	70 mm (2.8 in.)
C	45 mm (1.8 in.)
D	20 mm dia. (0.79 in. dia.)
E	11.7 to 11.9 mm dia. (0.461 to 0.469 in. dia.)
F	6.50 to 6.60 mm dia. (0.256 to 0.260 in. dia.)
G	25 mm (0.98 in.)
H	6.70 to 7.00 mm dia. (0.264 to 0.276 in. dia.)
I	5 mm (0.2 in.)
J	20 mm dia. (0.79 in. dia.)
K	12.5 to 12.8 mm dia. (0.493 to 0.503 in. dia.)
L	8.90 to 9.10 mm (0.351 to 0.358 in.)
C1	Chamfer 1.0 mm (0.039 in.)
C2	Chamfer 2.0 mm (0.079 in.)
C0.3	Chamfer 0.3 mm (0.01 in.)

9Y1210982GEG0072US0

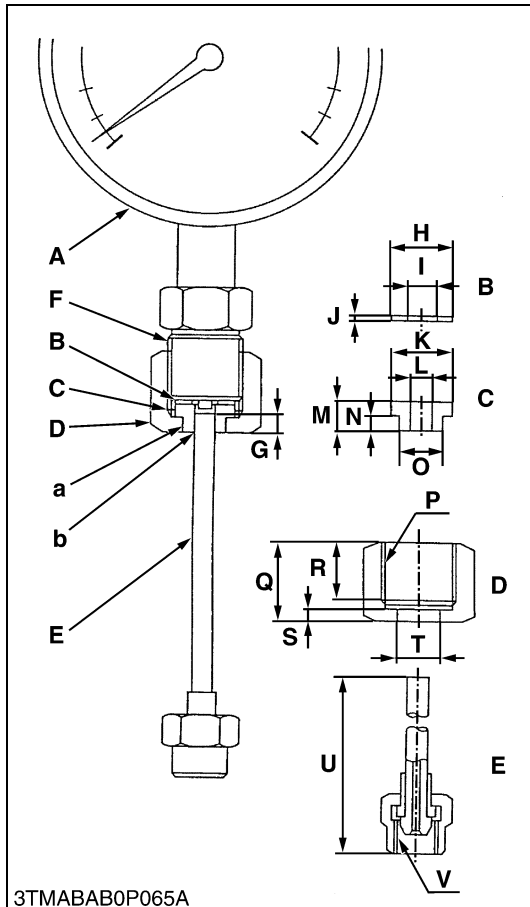

Injection Pump Pressure Tester

Application

- Use to check fuel tightness of injection pumps.

NOTE

- The following special tools are not provided, so make them referring to the figure.

A	Pressure gauge full scale: More than 29.4 MPa (300 kgf/cm ² , 4267 psi)
B	Copper gasket
C	Flange (Material: Steel)
D	Hex. nut 27 mm (1.1 in.) across the plat
E	Injection pipe
F	PF 1/2
G	5 mm (0.2 in.)
H	17 mm dia. (0.67 in. dia.)
I	8 mm dia. (0.3 in. dia.)
J	1.0 mm (0.039 in.)
K	17 mm dia. (0.67 in. dia.)
L	6.10 to 6.20 mm dia. (0.241 to 0.244 in. dia.)
M	8 mm (0.3 in.)
N	4 mm (0.2 in.)
O	11.97 to 11.99 mm dia. (0.4713 to 0.4720 in. dia.)
P	PF 1/2
Q	23 mm (0.91 in.)
R	17 mm (0.67 in.)
S	4 mm (0.2 in.)
T	12.00 to 12.02 mm dia. (0.4725 to 0.4732 in. dia.)
U	100 mm (3.94 in.)
V	M12 × 1.5
a	Adhesive application
b	Fillet welding on the enter circumference

9Y1210982GEG0073US0

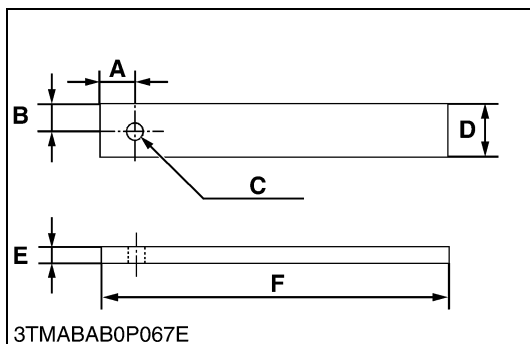

Flywheel Stopper

Application

- Use to loosen and tighten the flywheel screw.

NOTE

- The following special tools are not provided, so make them referring to the figure.

A	20 mm (0.79 in.)
B	15 mm (0.59 in.)
C	10 mm dia. (0.39 in. dia.)
D	30 mm (1.2 in.)
E	8 mm (0.3 in.)
F	200 mm (7.87 in.)

9Y1210982GEG0074US0

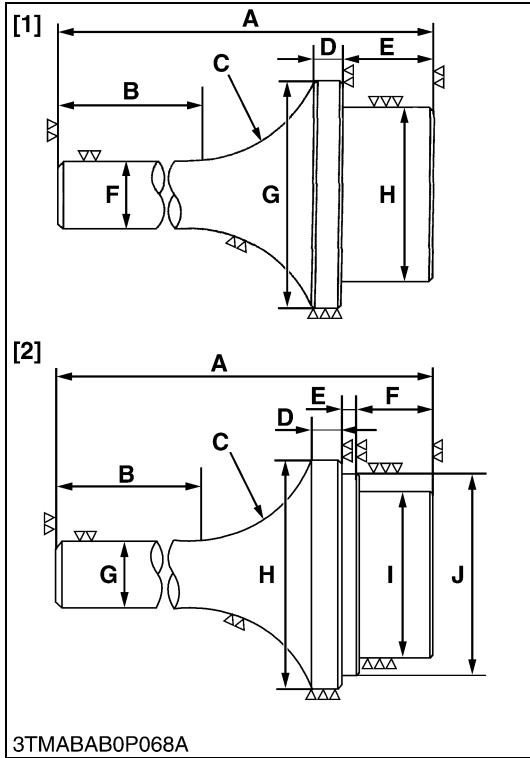

Crankshaft Bearing 1 Replacing Tool

Application

- Use to press out and press fit the crankshaft bearing 1.

NOTE

- The following special tools are not provided, so make them referring to the figure.

[Extracting tool]

A	135 mm (5.31 in.)
B	72 mm (2.8 in.)
C	40 mm radius (1.6 in. radius)
D	10 mm (0.39 in.)
E	20 mm (0.79 in.)
F	20 mm dia. (0.79 in. dia.)
G	56.80 to 56.90 mm dia. (2.237 to 2.240 in. dia.)
H	51.80 to 51.90 mm dia. (2.040 to 2.043 in. dia.)

[Inserting tool]

A	130 mm (5.12 in.)
B	72 mm (2.8 in.)
C	40 mm radius (1.6 in. radius)
D	9 mm (0.4 in.)
E	24 mm (0.2 in.)
F	20 mm (0.79 in.)
G	20 mm dia. (0.79 in. dia.)
H	68 mm dia. (2.7 in. dia.)
I	51.80 to 51.90 mm dia. (2.040 to 2.043 in. dia.)
J	56.80 to 56.90 mm dia. (2.237 to 2.240 in. dia.)

9Y1210982GEG0075US0

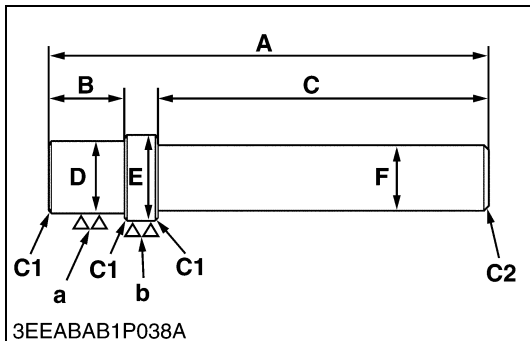

Bushing Replacing Tool

Application

- Use to press out and press in the bushing.

1. For small end bushing

A	157 mm (6.18 in.)
B	24 mm (0.94 in.)
C	120 mm (4.72 in.)
D	21.8 to 21.9 mm dia. (0.859 to 0.862 in. dia.)
E	24.8 to 24.9 mm dia. (0.977 to 0.980 in. dia.)
F	20 mm dia. (0.79 in. dia.)
a	6.3 μm (250 μin.)
b	6.3 μm (250 μin.)

2. For idle gear bushing

A	196 mm (7.72 in.)
B	26 mm (1.0 in.)
C	150 mm (5.91 in.)
D	25.80 to 25.90 mm dia. (1.016 to 1.019 in. dia.)
E	28.80 to 28.90 mm dia. (1.134 to 1.137 in. dia.)
F	20 mm dia. (0.79 in. dia.)
a	6.3 μm (250 μin.)
b	6.3 μm (250 μin.)

9Y1210982GEG0076US0

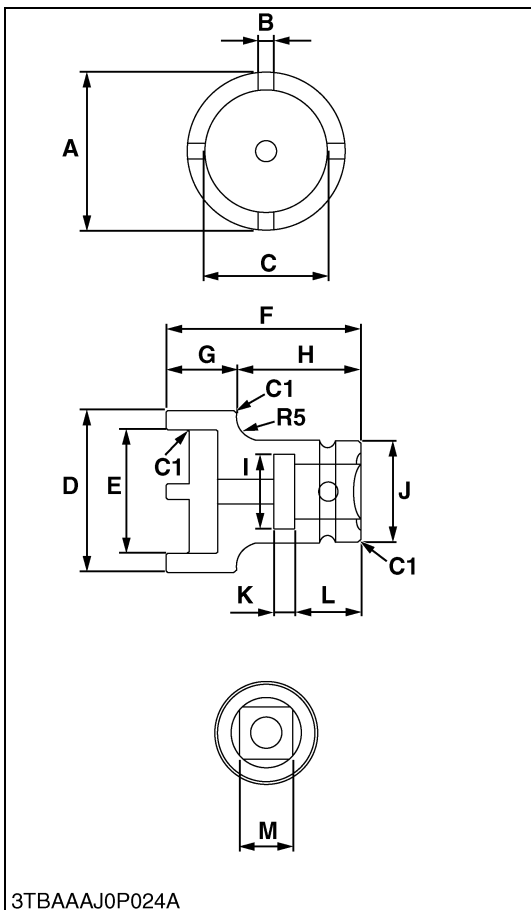

Socket

Application

- Use to loosen and tighten the idle gear 2 bearing lock nut.

NOTE

- The following special tools are not provided, so make them referring to the figure.

A	28.5 to 28.8 mm (1.12 to 1.13 in.)
B	3.5 to 3.7 mm (0.14 to 0.15 in.)
C	28.5 to 28.8 mm (0.12 to 1.13 in.)
D	38 mm dia. (1.50 in. dia.)
E	28.5 to 29.0 mm dia. (1.12 to 1.14 in. dia.)
F	47.5 mm (1.87 in.)
G	17.5 mm (0.69 in.)
H	30 mm (1.18 in.)
I	18 mm dia. (0.71 in. dia.)
J	24.5 mm dia. (0.96 in. dia.)
K	5.0 mm (0.21 in.)
L	16 mm (0.63 in.)
M	12.8 to 13.0 mm (0.50 to 0.51 in.)
C1	Chamfer 1.0 mm (0.039 in.)
R5	5.0 mm radius (0.20 in. radius)

9Y1210982GEG0077US0

[2] SPECIAL TOOLS FOR TRACTOR

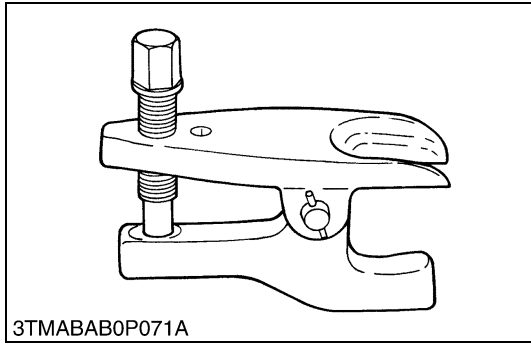

3TMABAB0P071A

Tie-rod End Lifter

Code No.

- 07909-39051

Application

- Use to remove the tie-rod end with ease.

WSM000001GEG0029US0

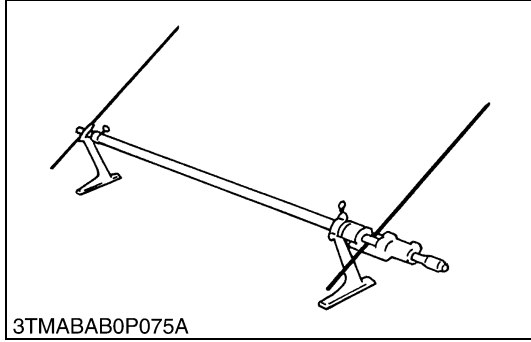

3TMABAB0P075A

Toe-in Gauge

Code No.

- 07909-31681

Application

- This allows easy measurement of toe-in for all machine models.

WSM000001GEG0034US0

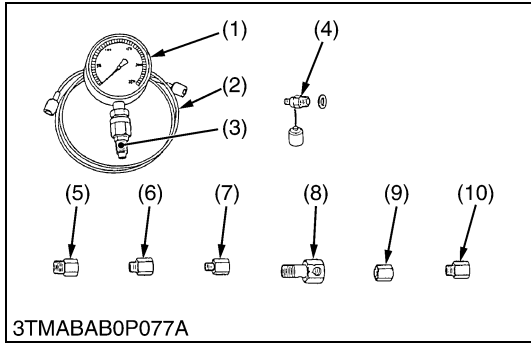

3TMABAB0P077A

Relief Valve Pressure Tester

Code No.

- 07916-50045

Application

- This allows easy measurement of relief set pressure.

- | | |
|--|---------------------------------------|
| (1) Gauge (07916-50322) | (6) Adaptor C (PS3/8) (07916-50371) |
| (2) Cable (07916-50331) | (7) Adaptor D (PT1/8) (07916-50381) |
| (3) Threaded Joint (07916-50401) | (8) Adaptor E (PS3/8) (07916-50392) |
| (4) Threaded Joint (07916-50341) | (9) Adaptor F (PF1/2) (07916-62601) |
| (5) Adaptor B (M18 × P1.5) (07916-50361) | (10) Adaptor 58 (PT1/4) (07916-52391) |

WSM000001GEG0027US0

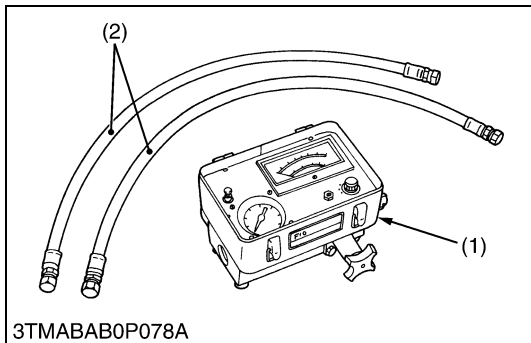

3TMABAB0P078A

Flow Meter

Code No.

- 07916-52791 (Flow Meter)
- 07916-52651 (Hydraulic Test Hose)

Application

- This allows easy testing of hydraulic system.

- | | |
|----------------|-------------------------|
| (1) Flow Meter | (2) Hydraulic Test Hose |
|----------------|-------------------------|

WSM000001GEG0036US0

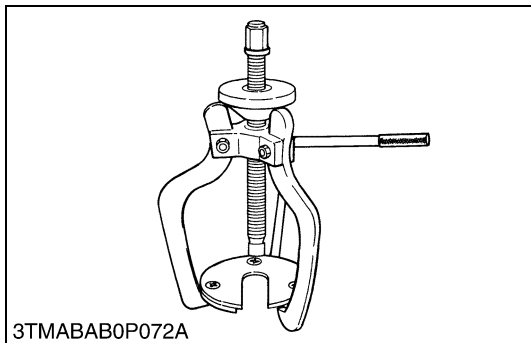

3TMABAB0P072A

Steering Wheel Puller

Code No.

- 07916-51090

Application

- Use to remove the steering wheel without damage to the steering shaft.

WSM000001GEG0030US0

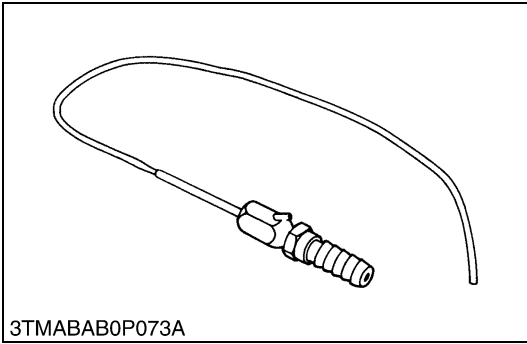

3TMABAB0P073A

Injector CH3

Code No.

- 07916-52501

Application

- Use to put calcium chloride solution into a rear wheel and to remove it.

WSM000001GEG0031US0

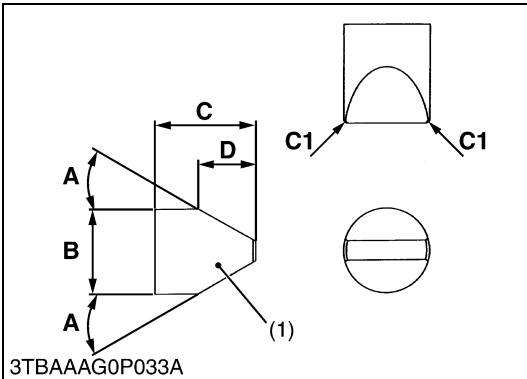

3TBAAAG0P033A

PTO Shift Arm Ball Guide

Application

- Use for compressing the ball and spring into the transmission case.

A	0.51 rad (30 °)
B	29.95 to 29.98 mm dia. (1.179 to 1.180 in. dia.)
C	35 mm (1.38 in.)
D	20 mm (0.79 in.)
C1	Chamfer 1 mm (0.039 in.)

(1) PTO Shift Arm Ball Guide

9Y1210982GEG0078US0

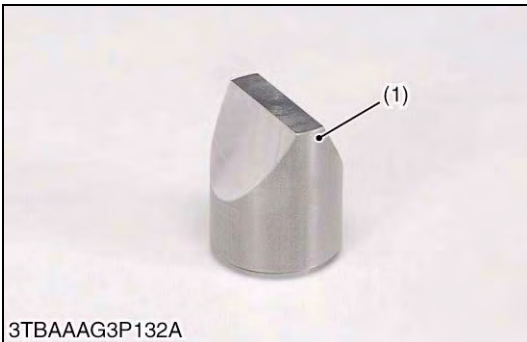

3TBAAAG3P132A

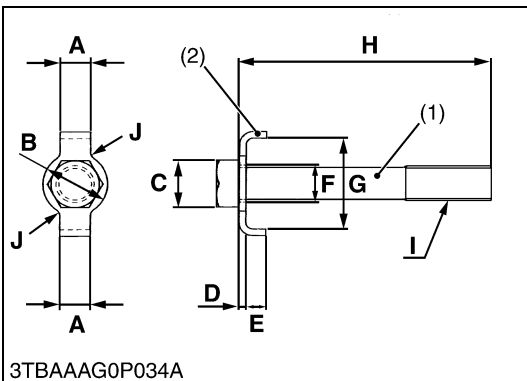

3TBAAAG0P034A

Independent PTO Clutch Spring Compression Tool

Application

- Use for compressing the spring into the spline boss. This tool can be used for B30 series, BX50 series and BX24 tractor.

A	12 mm (0.47 in.)
B	25.4 mm (1.00 in.)
C	19 mm radius (0.75 in.) Hex.
D	2.7 mm (0.11 in.)
E	8 mm (0.3 in.)
F	15 mm dia. (0.59 in. dia.)
G	37 mm (1.5 in.)
H	70 mm (2.76 in.)
I	M14 x1.5
J	R 3.0 mm (0.12 in.)
K	30 mm (1.18 in.)
L	17 mm (0.67 in.)
M	38 mm (1.50 in.)

9Y1210982GEG0079US0

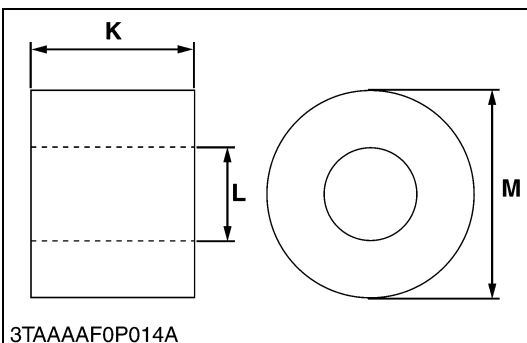

3TAAAAF0P014A

Check and High Pressure Relief Valve Assembly Tool

Application

- Use for Readjusting relief valve pressure.

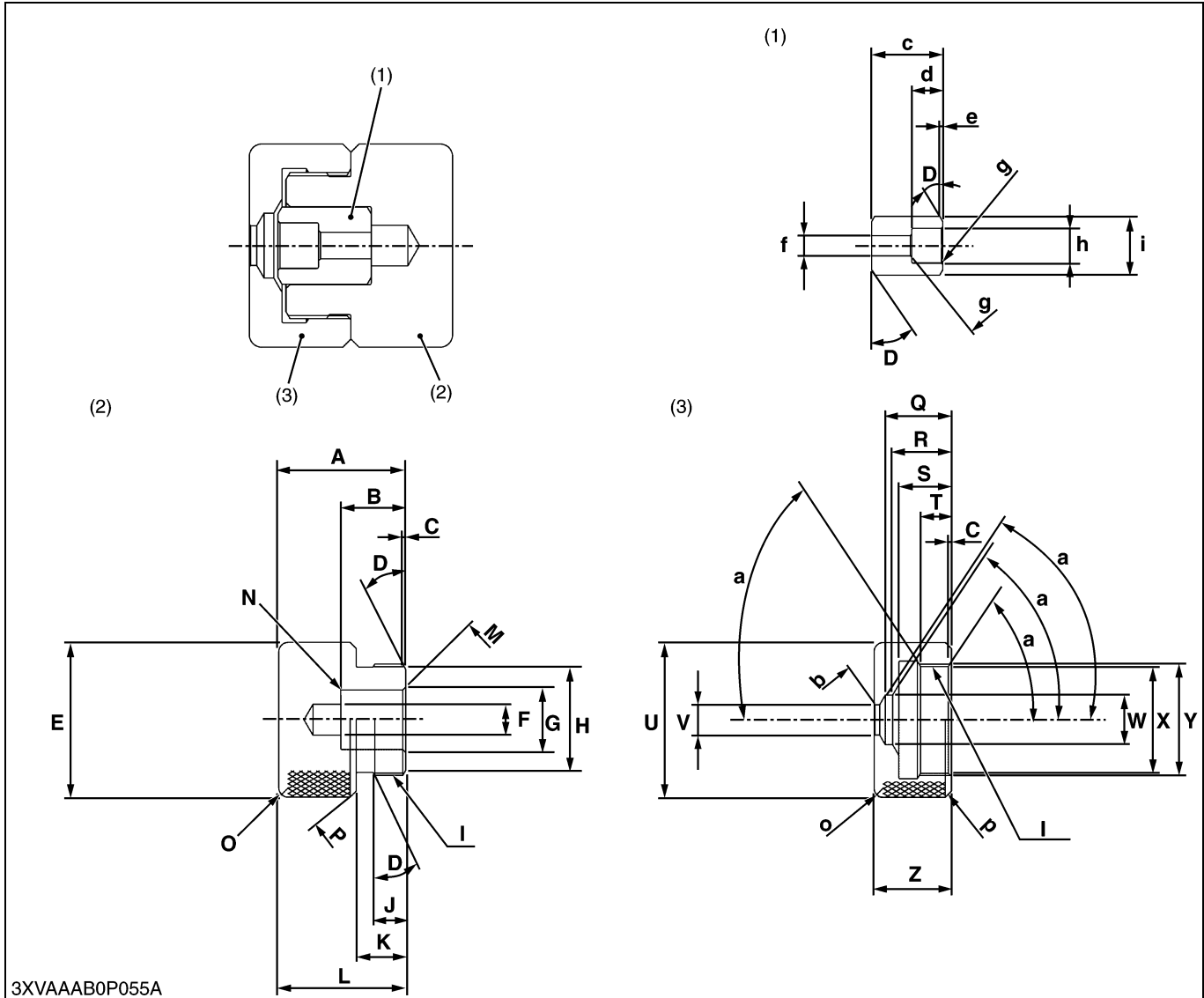

3XVAAAB0P055A

A	30.0 mm (1.18 in.)	N	Chamfer 0.4 mm (0.12 in.)	a	1.05 rad (60.0 °)
B	21.0 mm (0.827 in.)	O	Chamfer 3.0 mm (0.12 in.)	b	Chamfer 0.3 mm (0.01 in.)
C	1 mm (0.04 in.)	P	Chamfer 2.0 mm (0.079 in.)	c	23.0 mm (0.906 in.)
D	0.52 rad (30 °)	Q	21.4 mm (0.843 in.)	d	10.0 mm (0.394 in.)
E	50.0 mm dia. (1.97 in. dia.)	R	19.0 mm (0.748 in.)	e	1 mm (0.039 in.)
F	10.0 mm dia. (0.39 in. dia.)	S	17.0 mm (0.669 in.)	f	6.5 mm (0.26 in.)
G	9.10 to 9.30 mm dia. (0.359 to 0.366 in.)	T	10.0 mm (0.394 in.)	g	Chamfer 0.5 mm (0.02 in.)
H	34.0 mm dia. (1.34 in. dia.)	U	50.0 mm dia. (1.97 in. dia.)	h	11.1 to 11.3 mm (0.437 to 0.444 in.)
I	M36 x 1.5 mm Pitch	V	9.8 mm dia. (0.39 in. dia.)	i	18.8 to 19.0 mm (0.741 to 0.748 in.)
J	10.0 mm (0.39 in.)	W	16.0 mm dia. (0.630 in. dia.)		
K	16.0 mm (0.63 in.)	X	34.5 mm dia. (1.36 in. dia.)	(1)	Spacer (for ZD and ZG Series)
L	41.0 mm (1.61 in.)	Y	38.0 mm dia. (1.50 in. dia.)	(2)	Block
M	Chamfer 1 mm (0.04 in.)	Z	25.0 mm (0.984 in.)	(3)	Cap

9Y1210982GEG0080US0

[3] SPECIAL TOOLS FOR CABIN

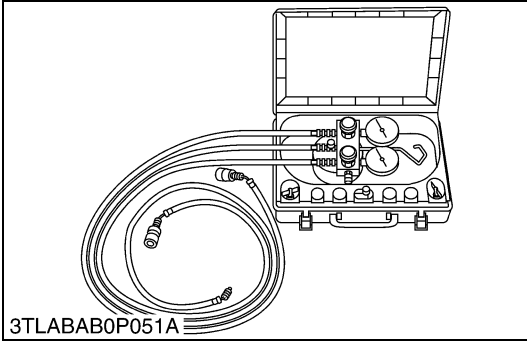

Air Conditioner Service Tool

Code No.

- DENSO 95048-00063

Application

- Use for charge, test or discharge of the air conditioning system.

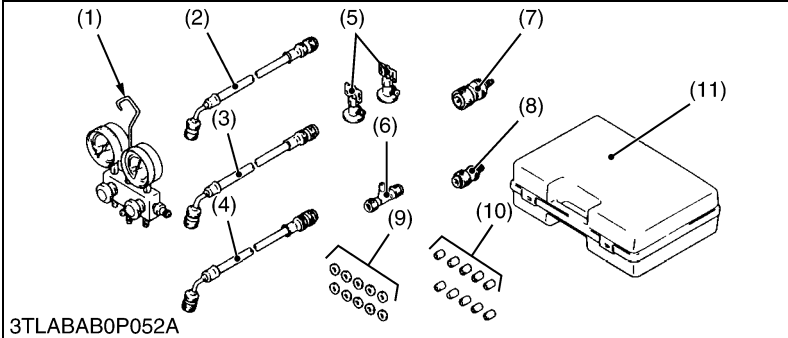

- (1) Manifold Gauge Assembly (95048-10090)
- (2) Charging Hose (Red: HI) (95948-10270)
- (3) Charging Hose (Blue: LO) (95948-10280)
- (4) Charging Hose (Green) (95948-10260)
- (5) Can Tap Valve (95048-10150)
- (6) T Joint (95048-10160)
- (7) Quick Coupler (HI) (95048-10130)
- (8) Quick Coupler (LO) (95048-10140)
- (9) Service Valve Packing (95906-10310)
- (10) Charging Hose Packing (95906-10300)
- (11) Tool Case (95949-10610)

WSM000001GEG0042US0

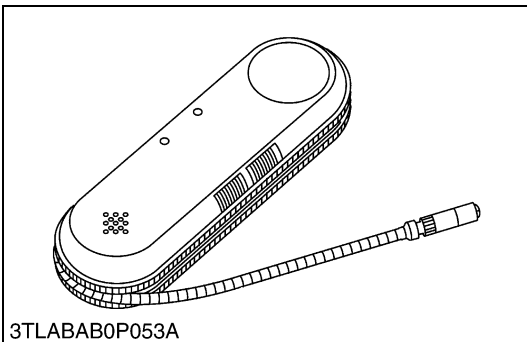

Electric Gas Leak Tester

Code No.

- DENSO 95146-00060

Application

- Use for gas leak test of the air conditioning system.

WSM000001GEG0043US0

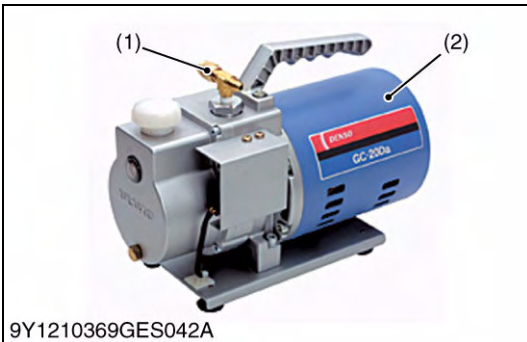

Vacuum Pump

Code No.

- DENSO 95046-00130 (AC220V)
- DENSO 95046-00140 (AC240V)

Application

- Use to evacuate the air conditioning system.

- (1) Adaptor (For R134a)
- (2) Vacuum Pump

WSM000001GEG0044US0

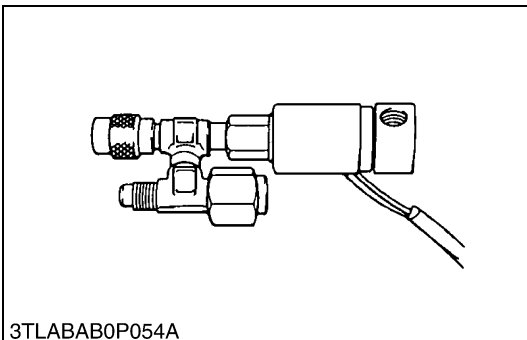

Adaptor (For R134a)

Code No.

- DENSO 95048-10190 (AC220V)
- DENSO 95048-10200 (AC240V)

Application

- Use to evacuate the air conditioning system.

WSM000001GEG0045US0

Stopper Magnet Clutch (For A/C Compressor)

Application

- Use for loosen and tighten the magnet clutch mounting nut.

NOTE

- This special tool is not provided, so make it referring to the figure.

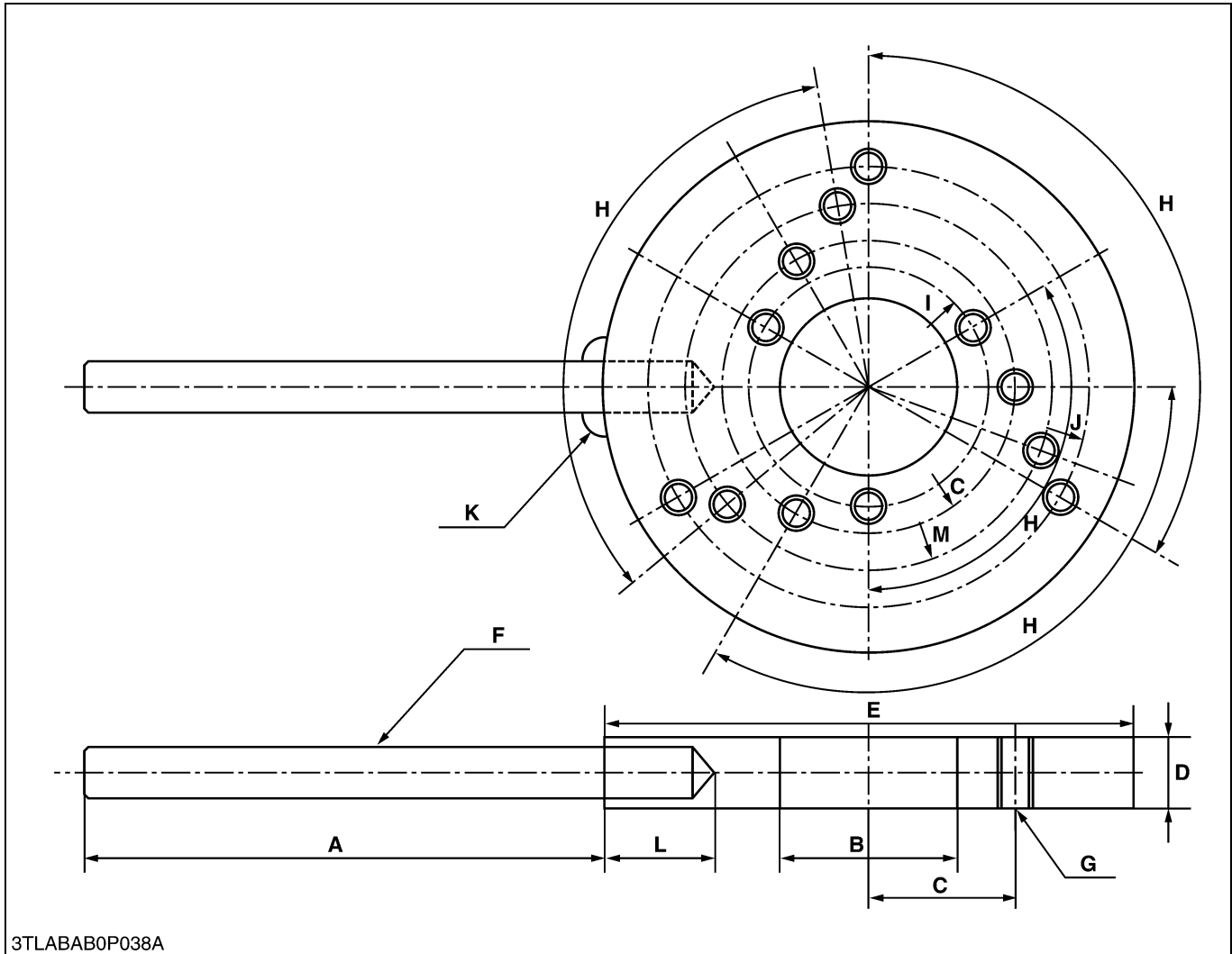

3TLABAB0P038A

A	125 mm (4.92 in.)	H	4.52 rad (120 °)
B	40 mm dia. (1.57 in. dia.)	I	Radius 27 mm (Radius 1.06 in.)
C	Radius 33 mm (Radius 1.30 in.)	J	Radius 50 mm (Radius 1.97 in.)
D	16 mm (0.63 in.)	K	Weld all around
E	120 mm dia. (4.72 in. dia.)	L	20 mm (0.78 in.)
F	12 mm dia. (0.47 in. dia.)	M	Radius 41 mm (Radius 1.61 in.)
G	3 × M8 × 1.25 All screws		

9Y1210982GEG0081US0

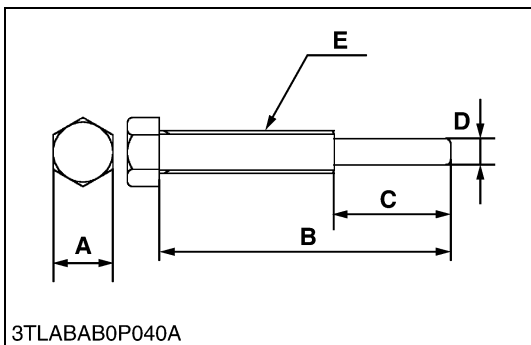

Remove Magnet Clutch (for A/C Compressor)

Application

- Use to remove the hub plate or center piece.

■ **NOTE**

- This special tool is not provided, so make it referring to the figure.

A	12 mm (0.47 in.)
B	55 mm (2.16 in.)
C	20 mm (0.79 in.)
D	5 mm dia. (0.20 in. dia.)
E	M8 × P1.25

9Y1210982GEG0082US0

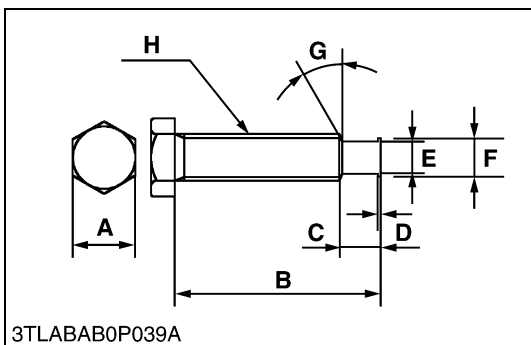

Stopper Bolt (for A/C Compressor)

Application

- Use with the stopper magnet clutch.

■ **NOTE**

- This special tool is not provided, so make it referring to the figure.

A	12 mm (0.47 in.)
B	35 mm (1.38 in.)
C	7 mm (0.28 in.)
D	0.4 mm (0.016 in.)
E	5.5 mm dia. (0.22 in. dia.)
F	6.5 mm dia. (0.26 in. dia.)
G	0.52 rad (30 °)
H	M8 × P1.25

9Y1210982GEG0083US0

9. TIRES

[1] TIRE PRESSURE



WARNING

To avoid personal injury or death:

- Do not attempt to mount a tire on a rim. This should be done by a qualified person with the proper equipment.
- Always maintain the correct tire pressure. Do not inflate tires above the recommended pressure shown in the operator's manual.

■ IMPORTANT

- Do not use tires other than those approved by KUBOTA.

Though the tire pressure is factory-set to the prescribed level, it naturally drops slowly in the course of time. Thus, check it everyday and inflate as necessary.

[B2050, B2350, B2650]

	Tire sizes	Inflation Pressure
Rear	8-16, 4PR	160 kPa (1.6 kgf/cm ² , 23 psi)
	9.5-16, 4PR	140 kPa (1.4 kgf/cm ² , 20 psi)
	9.5-18, 4PR	140 kPa (1.4 kgf/cm ² , 20 psi)
	315/75D-15, 4PR	100 kPa (1.0 kgf/cm ² , 14 psi)
	31 x 13.5-15, 4PR	140 kPa (1.4 kgf/cm ² , 20 psi)
Front	6-12B, 4PR	200 kPa (2.0 kgf/cm ² , 28 psi)
	6-12, 4PR	200 kPa (2.0 kgf/cm ² , 28 psi)
	6.00-12, 4PR	180 kPa (1.8 kgf/cm ² , 26 psi)
	24 x 8.50-12, 4PR	160 kPa (1.6 kgf/cm ² , 23 psi)
	22 x 8.50-12, 4PR	160 kPa (1.6 kgf/cm ² , 23 psi)

[B3150]

	Tire sizes	Inflation Pressure
Rear	12.4-16, 4PR	120 kPa (1.2 kgf/cm ² , 17 psi)
	13.6-16, 4PR	100 kPa (1.0 kgf/cm ² , 14 psi)
Front	180/85D12, 4PR	160 kPa (1.6 kgf/cm ² , 23 psi)
	24 x 8.50-12, 4PR	160 kPa (1.6 kgf/cm ² , 23 psi)

■ NOTE

- Maintain the maximum recommended pressure in the front tires, when using a front loader or when equipped with a full load of front weights.

■ Dual Tires

Dual tires are not approved.

9Y1210982GEG0084US0

[2] WHEEL ADJUSTMENT

WARNING

To avoid personal injury or death:

- When working on slopes or when working with trailer, set the wheel tread as wide as practical for maximum stability.
- Support tractor securely on stands before removing a wheel.
- Do not work under any hydraulically supported devices. They can settle, suddenly leak down, or be accidentally lowered. If necessary to work under tractor or any machine elements for servicing or adjustment, securely support them with stands or suitable blocking beforehand.
- Never operate tractor with a loose rim, wheel, or axle.

9Y1210982GEG0085US0

(1) Front Wheels

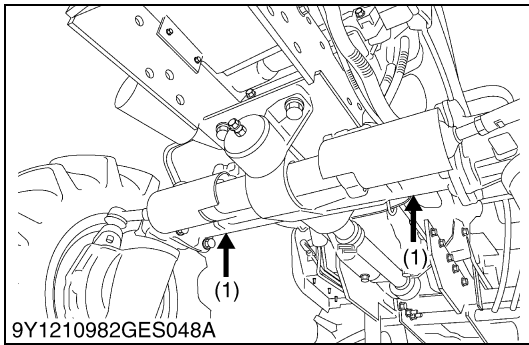

Front Wheels

Front tread width can not be adjusted.

■ IMPORTANT

- Do not turn front discs to obtain wider tread. In setting up the front wheels, make sure that the inflation valve stem of the tires face outward.
- When re-fitting or adjusting a wheel, tighten the bolts to the following torques then recheck after driving the tractor 200 m (200 yards) and 10 times of shuttle movement by 5 m (5 yards), and thereafter according to service interval. (See "MAINTENANCE" section.)

WARNING

To avoid personal injury or death:

- Before jacking up the tractor, park it on a firm and level ground and chock the rear wheels.
- Fix the front axle to keep it from swinging.
- Select jacks that withstand the machine weight and set them up as shown below.

(1) Jack Point

9Y1210982GEG0086US0

Front Wheels Treads

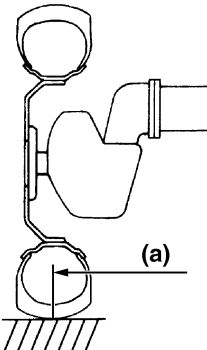
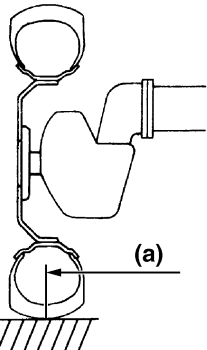
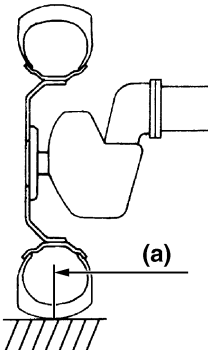
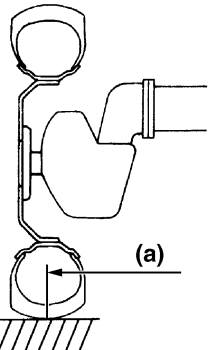
Model	B2050, B2350, B2650		B2050, B2350, B2650		B2050, B2350, B2650		B3150	
Tires	6-12B Farm		6.00-12 Farm	6-12 Farm	24 x 8.50-12 Turf	22 x 8.50-12 Turf	180/85D12 Farm	24 x 8.50-12 Turf
								
	9Y0211304GES003B		9Y0211304GES003B		9Y0211304GES003B		9Y0211304GES003B	
Tread	832 mm (32.8 in.)		830 mm (32.7 in.)	832 mm (32.8 in.)	871 mm (34.3 in.)	873 mm (34.4 in.)	936 mm (36.8 in.)	971 mm (38.2 in.)

9Y1210982GEG0087US0

(2) Rear Wheels

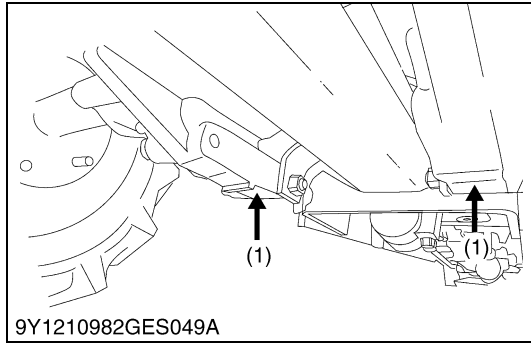

Rear Wheels

Rear tread width can not be adjusted.

■ IMPORTANT

- Always attach tires as shown in the drawings.
- If not attached as illustrated, transmission parts may be damaged.
- When re-fitting or adjusting a wheel, tighten the bolts to the following torques then recheck after driving the tractor 200 m (200 yards) and 10 times of shuttle movement by 5 m (5 yards), and thereafter according to service interval. (See "MAINTENANCE" section.)

⚠ WARNING

To avoid personal injury or death:

- Before jacking up the tractor, park it on a firm and level ground and chock the front wheels.
- Fix the front axle to keep it from swinging.
- Select jacks that withstand the machine weight and set them up as shown below.

(1) Jack Point

9Y1210982GEG0088US0

Rear Wheels Tread

Model	B2050, B2350, B2650		B2050, B2350, B2650		B2050, B2350, B2650		B3150	
Tires	8-16 Farm		9.5-16 Farm	9.5-18 Farm	31 x 13.5-15 Turf	315/75D-15 Turf	12.4-16 Farm	13.6-16 Farm
	9Y1210982GES050A		9Y1210982GES050A		9Y1210982GES050A		9Y1210982GES050A	
Tread	882 mm (34.7 in.)		986 mm (38.8 in.)	1006 mm (39.61 in.)	1056 mm (41.57 in.)	1056 mm (41.57 in.)	1050 mm (41.34 in.)	1050 mm (41.34 in.)

9Y1210982GEG0089US0

[3] BALLAST



WARNING

To avoid personal injury or death:

- Additional ballast will be needed for transporting heavy implements. When the implement is raised, drive slowly over rough ground, regardless of how much ballast is used.
- Do not fill the front wheels with liquid.

9Y1210982GEG0090US0

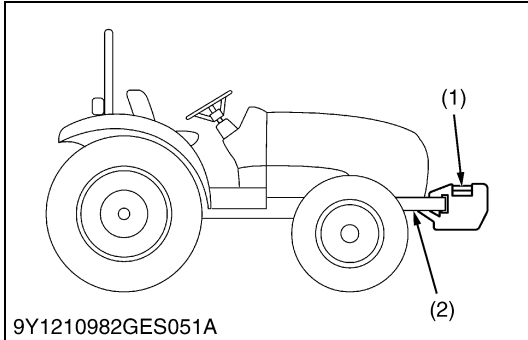

Front Ballast

Add weights if needed for stability and improving traction. Heavy pulling and heavy rear mounted implements tend to lift front wheels. Add enough ballast to maintain steering control and prevent tip over.

Remove weight when no longer needed.

■ **Front End Weights (option)**

The front end weights can be attached to the bumper.

■ **NOTE**

[For installation of up to 3 weights] (Except CAB model)

- Besides the weight, mounting bolt kit(s) are required for mounting the weight.

[For installation of up to 5 weights]

- Besides the weight, a front weight bracket and mounting bolt kit(s) are required for mounting the weight.

■ **IMPORTANT**

- Do not overload tires.
- Add no more weight than indicated in chart.

Maximum weight	25 kg (55 lbs) x 5 pieces [125 kg (276 lbs)]
----------------	---

(1) Front End Weights

(2) Front Weight Bracket (Option)

9Y1210982GEG0091US0

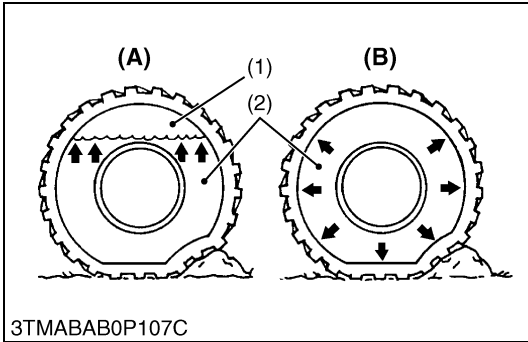

Rear Ballast

Add weight to rear wheels if needed to improve traction or for stability. The amount of rear ballast should be matched to job and the ballast should be removed when it is not needed.

The weight should be added to the tractor in the form of liquid ballast.

■ **Liquid Ballast in Rear Tires**

Water and calcium chloride solution provides safe economical ballast. Used properly, it will not damage tires, tubes or rims. The addition of calcium chloride is recommended to prevent the water from freezing. Use of this method of weighting the wheels has the full approval of the tire companies.

Liquid weight per tire (75 Percent filled)

Tire sizes	12.4-16	12.4-16	12.4-16	12.4-16
Slush free at -10 °C (14 °F) Solid at -30 °C (-22 °F) [Approx. 1 kg (2 lbs) CaCl ₂ per 4 L (1 gal) of water]	35 kg (77 lbs)	54 kg (120 lbs)	70 kg (150 lbs)	85 kg (190 lbs)
Slush free at -24 °C (-11 °F) Solid at -47 °C (-53 °F) [Approx. 1.5 kg (3.3 lbs) CaCl ₂ per 4 L (1 gal) of water]	37 kg (82 lbs)	57 kg (130 lbs)	74 kg (160 lbs)	89 kg (200 lbs)
Slush free at -47 °C (-53 °F) Solid at -52 °C (-62 °F) [Approx. 2.25 kg (4.96 lbs) CaCl ₂ per 4 L (1 gal) of water]	39 kg (86 lbs)	60 kg (130 lbs)	78 kg (170 lbs)	94 kg (210 lbs)

■ **IMPORTANT**

- **Do not fill tires with water or solution more than 75 % of full capacity (to the level of valve stem at 12 o'clock position).**

- (1) Air
- (2) Water

- (A) **Correct : 75% Full**
Air compresses like a cushion
- (B) **Incorrect : 100% Full**
Water can not be compressed

9Y1210982GEG0092US0

10. IMPLEMENT LIMITATIONS

The KUBOTA Tractor has been thoroughly tested for proper performance with implements sold or approved by KUBOTA. Use with implements which are not sold or approved by KUBOTA and which exceed the maximum specifications listed below, or which are otherwise unfit for use with the KUBOTA Tractor may result in malfunctions or failures of the tractor, damage to other property and injury to the operator or others. [Any malfunctions or failures of the tractor resulting from use with improper implements are not covered by the warranty.]

9Y1210982GEG0093US0

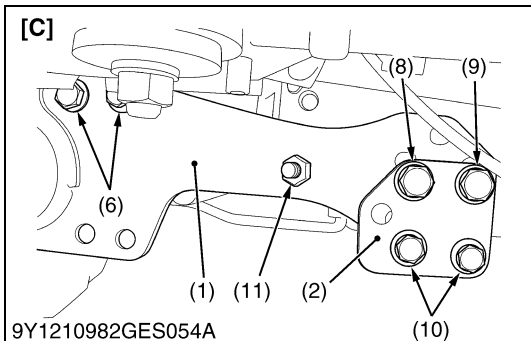
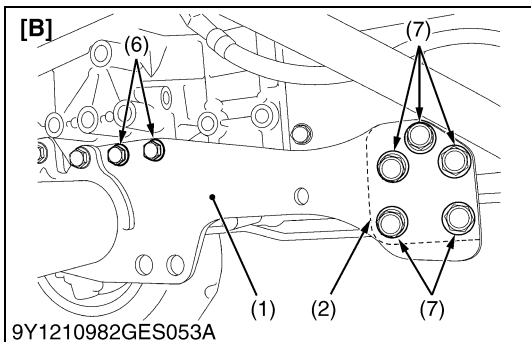
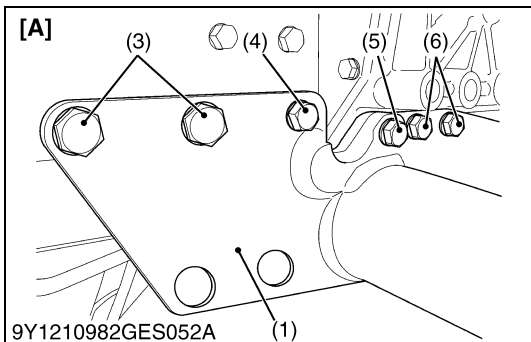

LA424 for B2050, B2350, B2650 [Attach the Main Frame: ROPS / CAB Type]

	Parts name	Tightening torque
(1)	Main frame	–
(2)	Spacer plate	–
(3)	2-M14 x 40 bolt with spring washer assembly 2-M14 plain washers	130 N·m 13.3 kgf·m 95.9 lbf·ft
(4)	1-M12 x 35 bolt with spring washer assembly 1-M12 plain washer	80 N·m 8.2 kgf·m 59 lbf·ft
(5)	1-M12 x 45 bolt with spring washer assembly 1-M12 plain washer	80 N·m 8.2 kgf·m 59 lbf·ft
(6)	2-M12 x 35 bolt with spring washer assembly 2-M12 plain washer	80 N·m 8.2 kgf·m 59 lbf·ft
(7)	5-M12 x 40 bolt with spring washer assembly 5-M12 plain washer 5-M12 nut	80 N·m 8.2 kgf·m 59 lbf·ft
(8)	1-M14 x 60 bolt 1-M14 plain washer 1-M14 spring lock washer 1-M14 nut	130 N·m 13.3 kgf·m 95.9 lbf·ft
(9)	1-M14 x 60 bolt 1-M14 plain washer 1-M14 spring lock washer	130 N·m 13.3 kgf·m 95.9 lbf·ft
(10)	2-M12 x 40 bolt with spring washer assembly 2-M12 plain washer 2-M12 nut	80 N·m 8.2 kgf·m 59 lbf·ft
(11)	1-M14 plain washer 1-M14 spring lock washer 1-M14 nut	128 N·m 13.1 kgf·m 94.4 lbf·ft

[A] ROPS and CAB Type (Front Side) [C] CAB Type (Back Side)
[B] ROPS Type (Back Side)

9Y1210982GEG0094US0

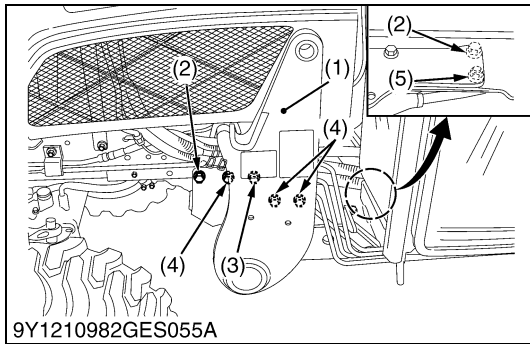

LA534 for B3150 [Attach the Main Frame: ROPS / CAB Type]

	Parts name	Tightening torque
(1)	Main frame	–
(2)	1-M14 1-M14 spring lock washers	150 N·m 15.3 kgf·m 111 lbf·ft
(3)	1-M12 (original) 1-M12 spring lock washers (original)	90 N·m 9.2 kgf·m 66 lbf·ft
(4)	2-M12 (original) 2-M12 spring lock washers (original)	80 N·m 8.2 kgf·m 59 lbf·ft
(5)	2-M14 (original) 2-M14 spring lock washers (original)	150 N·m 15.3 kgf·m 111 lbf·ft
(6)	1-M14 nut (original) 1-M14 spring lock washers (original)	128 N·m 13.1 kgf·m 94.4 lbf·ft

9Y1210982GEG0095US0

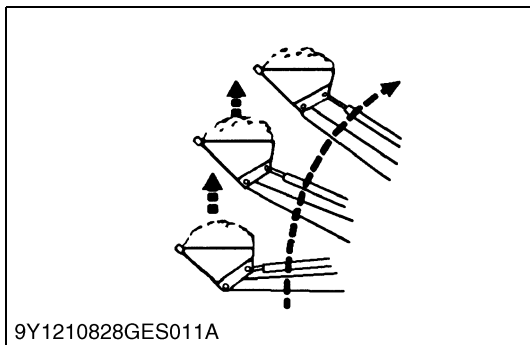

Output Capacity

[LA424]

- Max. Lifting Capacity (bucket pivot pin, MAX. Height): 420 kg (926 lbs)
- Max. Oil Pressure 16.6 MPa (169 kgf/cm², 2410 psi)

[LA534]

- Max. Lifting Capacity (bucket pivot pin, MAX. Height): 520 kg (1150 lbs)
- Max. Oil Pressure 16.6 MPa (169 kgf/cm², 2410 psi)

NOTE

- The value of MAX. Lifting capacity contains the weight of KUBOTA standard bucket.

! DANGER

To avoid personal injury or death:

- Special attention should be made when lifting the load, keep the bucket correctly positioned to prevent spillages.

NOTE

- Not all risks are listed. Refer to front loader operator's manual.

9Y1210982GEG0096US0

Other Implements

- Strictly follow the instructions outlined in the operator's manual of the mounted or trailed machinery or trailer, and do not operate the combination tractor - machine or tractor - trailer unless all instructions have been followed.
- Forestry Application
Following hazards exist;
 - a) toppling trees, primarily in case a rear-mounted tree grab-crane is mounted at the rear of the tractor;
 - b) penetrating objects in the operator's enclosure, primarily in case a winch is mounted at the rear of the tractor.
 Optional equipments such as OPS (Operator Protective Structure), FOPS (Falling Object Protective Structure), etc. to deal with these hazards and other related hazards are not available for this tractor.
Without such optional equipment use is limited to tractor specific applications like transport and stationary work.

9Y1210982GEG0097US0

1 ENGINE

MECHANISM

CONTENTS

1. ENGINE BODY	1-M1
[1] CLOSED BREATHER [D1105, V1505]	1-M1
[2] HALF-FLOATING HEAD COVER [D1305]	1-M1
[3] GOVERNOR	1-M2

1. ENGINE BODY

[1] CLOSED BREATHER [D1105, V1505]

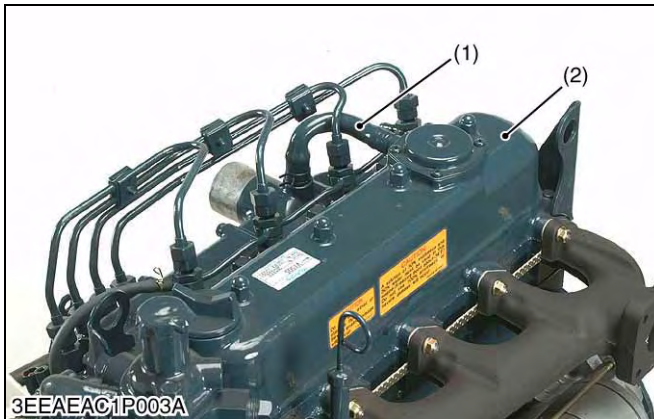

Closed breather system has been adopted to prevent the release of blow-by gas into the atmosphere.

After its oil content is filtered by oil shield (4), the blow by gas is fed back to the intake manifold through breather valve (3) to be used for re-combustion.

- | | |
|-------------------------|--------------------|
| (1) Breather Tube | (4) Oil Shield |
| (2) Cylinder Head Cover | (5) Rubber Packing |
| (3) Breather Valve | |

9Y1210982ENM0001US0

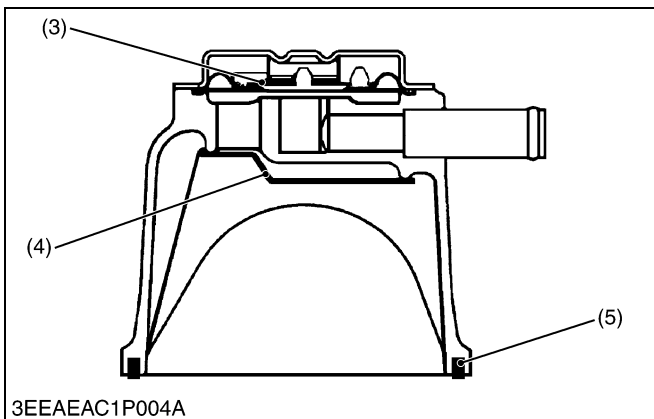

[2] HALF-FLOATING HEAD COVER [D1305]

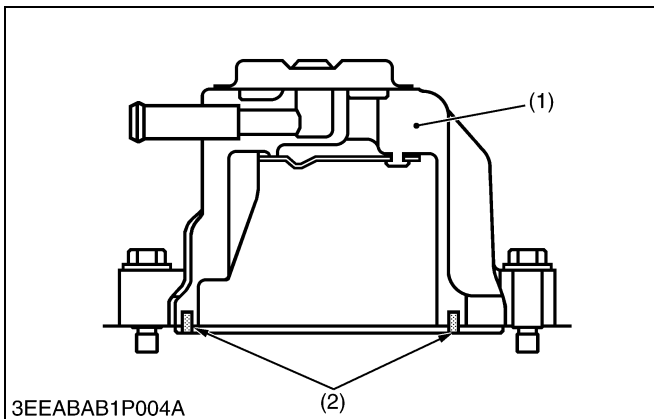

The rubber packing is fitted in to keep the cylinder head cover 0.5 mm (0.02 in.) or so off the cylinder head. This arrangement helps reduce noise coming from the cylinder head.

- | | |
|-------------------------|--------------------|
| (1) Cylinder Head Cover | (2) Rubber Packing |
|-------------------------|--------------------|

9Y1210982ENM0002US0

[3] GOVERNOR

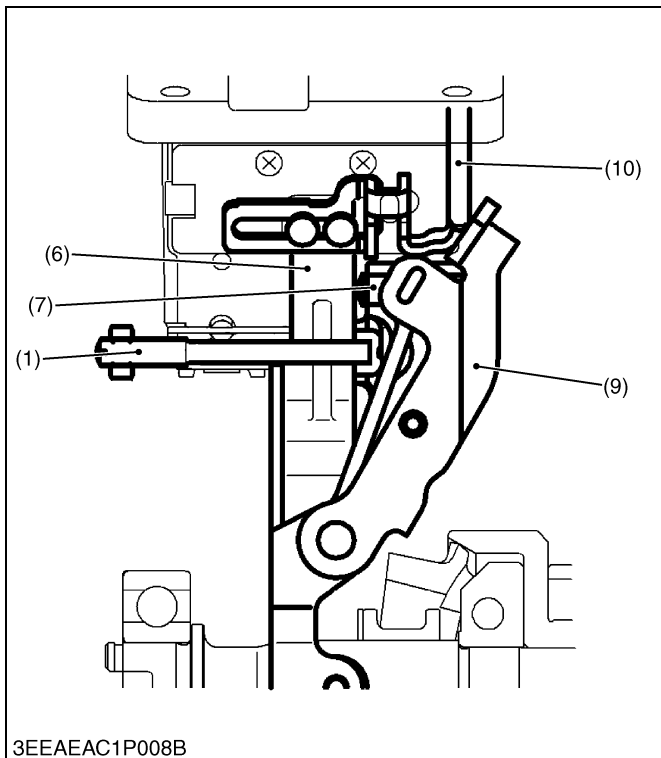
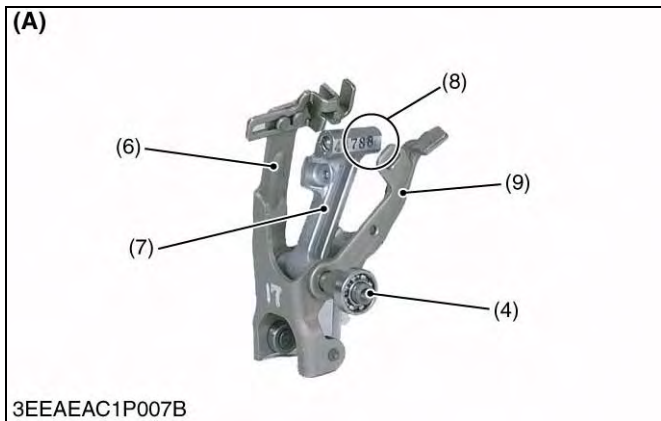
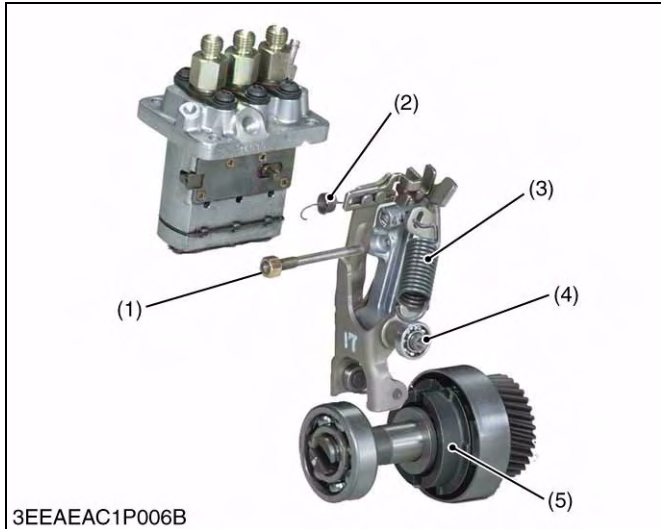

Three Lever Type Fork Lever

The governor system is a mechanical governor that used the flyweight (5).

The flyweight (5) is mounted on the governor shaft that rotates at the same speed as the crankshaft.

Because the feature of this mechanism takes out the engine speed directly as a centrifugal force of weight, the speed control that the change in the engine rotational speed is sensitively transmitted to fork lever assembly (A) and accuracy is high is enabled.

The fork lever assembly of this engine consists of fork lever 1 (6), for lever 2 (9), and the floating lever (7). A slide plate is installed in fork lever 1. The governor spring (3) is hooked to fork lever 2 (9).

The floating lever (7) installs the torque pin (8) of the output drop prevention at the overload. The start spring (2) is hooked to a slide plate, and holds the control rack in the direction of the full fuel position.

Fork lever 2 (9) and the floating lever are installed in fork lever 1 (6) with the fork lever shaft (4). The max torque limitation (1) device limits the amount of the fuel injection at the overload with the torque pin.

- | | |
|------------------------|--------------------|
| (1) Max Torque Limiter | (7) Floating Lever |
| (2) Start Spring | (8) Torque Pin |
| (3) Governor Spring | (9) Fork Lever 2 |
| (4) Fork Lever Shaft | |
| (5) Flyweight | |
| (6) Fork Lever 1 | |

(A) Fork Lever Assembly

9Y1210982ENM0003US0

(At Rated Operation)

When the engine operates, the fork lever 2 (9) and the floating lever (7) are moving with the fork lever 1 (6) due to the tension of the governor spring (3).

During the time, the torque pin (8) is pressed into the floating lever by centrifugal force of the governor weight (5).

The fork lever 2 (9) comes in contact with the fuel limitation bolt (10), and the fuel injection pump supplies a fuel necessary for rated operation.

- | | |
|------------------------|---------------------------|
| (1) Max Torque Limiter | (9) Fork Lever 2 |
| (6) Fork Lever 1 | (10) Fuel Limitation Bolt |
| (7) Floating Lever | |

9Y1210982ENM0004US0

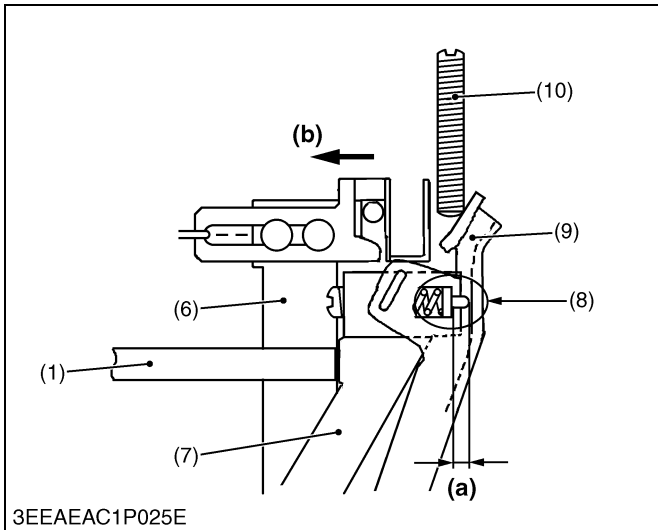
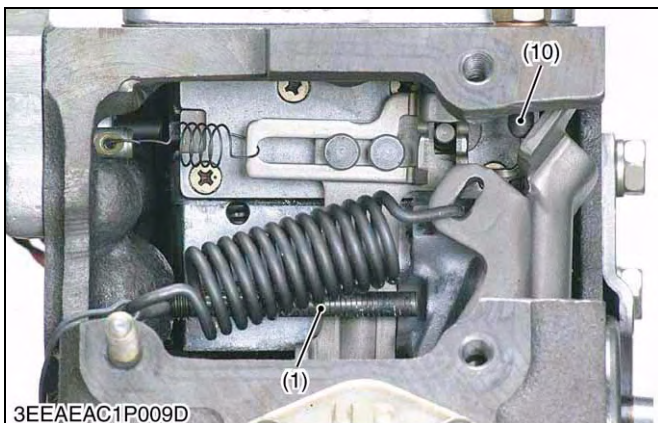

(Overloaded Operation)

The amount of the movement of the fork lever assembly is limited with the fuel limitation bolt (10) and can not be moved in the direction of the fuel increase.

As overload reduces the centrifugal force of the governor weight, which is pressing the torque pin (8) into the floating lever (7), the floating lever pushes the fork lever 1 (6) in the way to increase the fuel supply with the help of the torque spring tension.

The fuel supply increases (b) in relation to the degree of the torque pin motion, thus preventing the engine speed from dropping.

At the time, the maximum torque limiter (1) prevents superfluous fuel supply and suppresses the generation of black smoke.

- (1) Max Torque Limiter
- (6) Fork Lever 1
- (7) Floating Lever
- (8) Torque Pin
- (9) Fork Lever 2
- (10) Fuel Limitation Bolt

- (a) Distance to which torque pin (8) pushes fork lever 1 (6) out
- (b) Increase of fuel

9Y1210982ENM0005US0

SERVICING

CONTENTS

1. TROUBLESHOOTING.....	1-S1
2. SERVICING SPECIFICATIONS.....	1-S7
3. TIGHTENING TORQUES.....	1-S13
[1] TRACTOR SECTION.....	1-S13
[2] ENGINE SECTION.....	1-S13
4. CHECKING, DISASSEMBLING AND SERVICING.....	1-S14
[1] CHECKING AND ADJUSTING.....	1-S14
(1) Engine Body.....	1-S14
(2) Lubricating System.....	1-S16
(3) Cooling System.....	1-S17
(4) Fuel System.....	1-S19
[2] PREPARATION.....	1-S22
(1) Draining Lubricants and Coolant.....	1-S22
(2) Separating Engine from Clutch Housing (CABIN).....	1-S24
(3) Separating Engine from Front Axle Frame (CABIN).....	1-S27
(4) Separating Engine from Clutch Housing (ROPS).....	1-S27
(5) Separating Engine from Front Axle Frame (ROPS).....	1-S30
[3] DISASSEMBLING AND ASSEMBLING.....	1-S31
(1) External Components.....	1-S31
(2) Cylinder Head and Valve and Oil Pan.....	1-S32
(3) Gear Case.....	1-S34
(4) Piston and Connecting Rod.....	1-S38
(5) Crankshaft.....	1-S41
[4] SERVICING.....	1-S43
(1) Cylinder Head and Valves.....	1-S43
(2) Idle Gear and Camshaft.....	1-S49
(3) Piston and Connecting Rod.....	1-S51
(4) Crankshaft.....	1-S55
(5) Cylinder.....	1-S60
(6) Oil Pump.....	1-S61

1. TROUBLESHOOTING

Symptom	Probable Cause and Checking Procedure	Solution	Reference Page
Engine Does Not Start	1. No fuel	Check fuel	G-8
	2. Air in the fuel system	Bleed air	G-39
	3. Water in the fuel system	Solution order 1. Repair or replace fuel system	1-S19
		2. Change fuel	G-8
	4. Fuel hose clogged	Clean or replace fuel hose	G-28
	5. Fuel filter clogged	Solution order 1. Replace fuel filter	G-26
		2. Check or change fuel	G-8
	6. Excessively high viscosity of fuel or engine oil at low temperature	Check fuel or engine oil	G-8
	7. Fuel with low cetane number	Check fuel	G-8
	8. Fuel leak due to loose injection pipe retaining nut	Repair retaining nut	1-S32
	9. Incorrect injection timing	Solution order 1. Check injection timing	1-S19
		2. Adjust injection timing	
	10. Fuel camshaft worn	Solution order 1. Inspect cam shaft	1-S37
2. Replace cam shaft			
11. Injection nozzle clogged	Solution order 1. Inspect injection nozzle	1-S19	
	2. Replace or clean injection nozzle	1-S22	
12. Injection pump malfunctioning	Repair or replace injection pump	1-S36	
13. Seizure of crankshaft, camshaft, piston, cylinder or bearing	Solution order 1. Inspect crankshaft, camshaft, piston, cylinder or bearing	1-S50 to 1-S61	
	2. Replace crankshaft, camshaft, piston, cylinder or bearing	1-S37 to 1-S43	

Symptom	Probable Cause and Checking Procedure	Solution	Reference Page
Engine Does Not Start	14. Compression leak from cylinder	Solution order 1. Check compression pressure	1-S14
		2. Inspect or replace head gasket	1-S33
		3. Inspect or replace piston or piston ring	1-S40, 1-S54
		4. Inspect or replace cylinder	1-S60
	15. Improper valve timing	Check or replace timing gear	1-S37
	16. Piston ring and cylinder worn	Solution order 1. Inspect piston ring and cylinder	1-S54, 1-S60
		2. Replace piston ring or cylinder	1-S40, 1-S60
	17. Excessive valve clearance	Solution order 1. Check and adjust valve clearance	1-S15
	18. Stop solenoid malfunctioning	Solution order 1. Check or replace stop solenoid	9-S18
		2. Check or repair wire harness	9-M1 to 9-M3
Starter Does Not Run	1. Battery discharged	Charge battery	9-S10
	2. Starter malfunctioning	Solution order 1. Check or replace starter	9-S19
	3. Key switch malfunctioning	Check or replace key switch	9-S15

Symptom	Probable Cause and Checking Procedure	Solution	Reference Page
Engine Revolution Is Not Smooth	1. Fuel filter clogged or dirty	Solution order 1. Replace fuel filter	G-26
		2. Check or change fuel	G-8
	2. Air cleaner clogged	Clean or change air cleaner	G-24
	3. Fuel leak due to loose injection pipe retaining nut	Repair retaining nut	1-S32
	4. Injection pump malfunctioning	Replace injection pump	1-S36
		5. Incorrect nozzle injection pressure	Solution order 1. Check injection pressure
	2. Repair or clean injection nozzle		1-S22
	6. Injection nozzle stuck or clogged	Solution order 1. Check injection pressure	1-S21
		2. Repair or clean injection nozzle	1-S22
	7. Governor malfunctioning	Solution order 1. Check governor spring or fuel cam shaft	1-S36
2. Replace governor spring or fuel cam shaft		1-S36	
Either White or Blue Exhaust Gas Is Observed	1. Excessive engine oil	Reduce to specified level	G-8
	2. Piston ring and cylinder worn or stuck	Solution order 1. Inspect piston ring and cylinder	1-S54, 1-S60
		2. Replace piston ring or cylinder	1-S40, 1-S60
	3. Incorrect injection timing	Solution order 1. Check injection timing	1-S19
		2. Adjust injection timing	
	4. Deficient compression	Solution order 1. Check compression pressure	1-S14
		2. Inspect or replace head gasket	1-S33
		3. Inspect or replace piston or piston ring	1-S40, 1-S54
4. Inspect or replace cylinder		1-S60	

Symptom	Probable Cause and Checking Procedure	Solution	Reference Page
Oil Leak into Suction Pipe	1. Waste oil pipe clogged or deformed	Repair or replace pipe	1-S31
	2. Piston ring seal is damaged	Replace piston ring	1-S40
Either Black or Dark Gray Exhaust Gas Is Observed	1. Low grade fuel used	Check fuel	G-8
	2. Fuel filter clogged	Solution order 1. Replace fuel filter	G-26
		2. Check or change fuel	G-8
	3. Air cleaner clogged	Clean or change air cleaner	G-24
	4. Deficient nozzle injection	Solution order 1. Inspect injection nozzle	1-S19
2. Replace or clean injection nozzle		1-S22	
Deficient Output	1. Incorrect injection timing	Solution order 1. Check injection timing	1-S19
		2. Adjust injection timing	
	2. Injection pump malfunctioning	Replace injection pump	1-S36
	3. Uneven fuel injection	Replace injection pump	1-S36
	4. Deficient nozzle injection	Solution order 1. Inspect injection nozzle	1-S19
		2. Replace or clean injection nozzle	1-S22
	5. Compression leak	Solution order 1. Check compression pressure	1-S14
		2. Check or replace head gasket	1-S33
		3. Inspect or replace piston or piston ring	1-S40, 1-S54
		4. Inspect or replace cylinder	1-S60
6. Gas leak from exhaust system	Repair or replace exhaust system	1-S31	
7. Air cleaner dirty or clogged	Clean or change air cleaner	G-24	

Symptom	Probable Cause and Checking Procedure	Solution	Reference Page
Excessive Lubricant Oil Consumption	1. Piston ring's gap facing the same direction	Repair piston ring gap	1-S53
	2. Oil ring worn or stuck	Solution order 1. Inspect piston ring and cylinder	1-S54, 1-S60
		2. Replace piston ring or cylinder	1-S40, 1-S60
	3. Piston ring groove worn	Replace piston	1-S54
	4. Valve stem and valve guide worn	Inspect or replace valve stem and valve guide	1-S45
	5. Crankshaft bearing and crank pin bearing worn	Inspect or replace crankshaft and crank pin	1-S55
Fuel Mixed into Lubricant Oil	1. Injection pump's plunger worn	Repair or replace injection pump	1-S36
	2. Deficient nozzle injection	Repair or replace nozzle	1-S22
	3. Injection pump broken	Replace injection pump	1-S36
Water Mixed into Lubricant Oil	1. Head gasket damaged	Replace head gasket	1-S33
	2. Cylinder block or cylinder head flawed	Replace cylinder head	1-S33
Low Oil Pressure	1. Engine oil insufficient	Check engine oil	G-8
	2. Oil filter cartridge clogged	Replace oil filter cartridge	G-29
	3. Oil pump damaged	Replace oil pump	1-S61
	4. Excessive oil clearance of crankshaft bearing	Inspect or replace crankshaft bearing	1-S57 to 1-S59
	5. Excessive oil clearance of crankpin bearing	Inspect or replace crankshaft	1-S55
High Oil Pressure	1. Different type of oil	Check engine oil	G-8

Symptom	Probable Cause and Checking Procedure	Solution	Reference Page
Engine Overheated	1. Engine oil insufficient	Check engine oil	G-8
	2. Fan belt broken or elongated	Adjust or replace fan belt	1-S17
	3. Coolant insufficient	Check coolant	G-8
	4. Radiator net and radiator fin clogged with dust	Clean radiator net and fin	G-16
	5. Inside of radiator corroded	Clean or replace radiator	G-16
	6. Coolant flow route corroded	Clean coolant flow route	G-37
	7. Radiator cap damaged	Inspect or replace radiator cap	1-S18
	8. Radiator hose damaged	Check or replace radiator hose	G-31
	9. Thermostat valve damaged	Inspect or replace thermostat	1-S17
	10. Unsuitable fuel used	Check fuel	G-8
	11. Head gasket damaged	Replace head gasket	1-S33
	12. Incorrect injection timing	Solution order 1. Check injection timing 2. Adjust injection timing	1-S19
Battery Quickly Discharged	1. Battery electrolyte insufficient	Check or charge battery	9-S10
	2. Fan belt slips	Adjust or replace fan belt	1-S17
	3. Alternator damaged	Solution order 1. Check alternator 2. Replace alternator	9-M17 9-S40

9Y1210982ENS0122US0

2. SERVICING SPECIFICATIONS

ENGINE BODY

Item		Factory Specification	Allowable Limit
Compression Pressure		3.73 to 4.11 MPa 38.0 to 42.0 kgf/cm ² 541 to 597 psi	2.26 MPa 23.0 kgf/cm ² 327 psi
• Variance Among Cylinders		–	10 % or less
Valve Clearance (Cold)		0.145 to 0.185 mm 0.0057 to 0.0073 in.	–
Top Clearance	D1105, V1505	0.55 to 0.75 mm 0.022 to 0.029 in.	–
	D1305	0.80 to 1.0 mm 0.032 to 0.039 in.	–
Cylinder Head Surface		Flatness	0.05 mm 0.002 in.
Valve Recessing		Intake and Exhaust	0.050 to 0.25 mm 0.0020 to 0.0098 in.
Valve Stem to Valve Guide		Clearance	0.035 to 0.065 mm 0.0014 to 0.0025 in.
• Valve Stem		O.D.	6.960 to 6.975 mm 0.2741 to 0.2746 in.
• Valve Guide		I.D.	7.010 to 7.025 mm 0.2760 to 0.2765 in.
Valve Guide (Intake and Exhaust)			7.010 to 7.025 mm 0.2760 to 0.2765 in.
Valve Face	Angle (Intake)	1.047 rad 60 °	–
	Angle (Exhaust)	0.785 rad 45 °	–
Valve Seat	Angle (Intake)	1.047 rad 60 °	–
	Angle (Exhaust)	0.785 rad 45 °	–
	Width	2.12 mm 0.0835 in.	–
Valve Spring	Free Length	37.0 to 37.5 mm 1.46 to 1.47 in.	36.5 mm 1.44 in.
	Tilt	–	1.0 mm 0.039 in.
	Setting Load	117.4 N / 31.0 mm 11.97 kgf / 31.0 mm 26.39 lbf / 1.22 in.	100.0 N / 31.0 mm 10.20 kgf / 31.0 mm 22.48 lbf / 1.22 in.

Item		Factory Specification	Allowable Limit	
Rocker Arm Shaft to Rocker Arm	Clearance	0.016 to 0.045 mm 0.00063 to 0.0017 in.	0.10 mm 0.0039 in.	
	• Rocker Arm Shaft	O.D.	11.973 to 11.984 mm 0.47138 to 0.47181 in.	–
	• Rocker Arm	I.D.	12.000 to 12.018 mm 0.47244 to 0.47314 in.	–
Push Rod	Alignment	–	0.25 mm 0.0098 in.	
Tappet to Tappet Guide Bore	Clearance	0.020 to 0.062 mm 0.00079 to 0.0024 in.	0.07 mm 0.003 in.	
	• Tappet	O.D.	19.959 to 19.980 mm 0.78579 to 0.78661 in.	–
	• Tappet Guide	I.D.	20.000 to 20.021 mm 0.78740 to 0.78822 in.	–
Idle Gear	• Crank Gear to Idle Gear 1	Backlash	0.0320 to 0.115 mm 0.00126 to 0.00452 in.	0.15 mm 0.0059 in.
	• Idle Gear 1 to Cam Gear	Backlash	0.0360 to 0.114 mm 0.00142 to 0.00448 in.	0.15 mm 0.0059 in.
	• Idle Gear 1 to Injection Pump Gear	Backlash	0.0340 to 0.116 mm 0.00134 to 0.00456 in.	0.15 mm 0.0059 in.
	• Idle Gear 1 to Idle Gear 2	Backlash	0.0330 to 0.117 mm 0.00130 to 0.00460 in.	0.15 mm 0.0059 in.
Idle Gear	• Idle Gear 1	Side Clearance	0.20 to 0.51 mm 0.0079 to 0.020 in.	0.80 mm 0.031 in.
	• Idle Gear 2	Side Clearance	0.20 to 0.51 mm 0.0079 to 0.020 in.	0.80 mm 0.031 in.
Camshaft	Side Clearance	0.070 to 0.22 mm 0.0028 to 0.0086 in.	0.30 mm 0.012 in.	
	Alignment	–	0.01 mm 0.0004 in.	
Cam Height	Intake	28.80 mm 1.134 in.	28.75 mm 1.132 in.	
	Exhaust	29.00 mm 1.142 in.	28.95 mm 1.140 in.	
Camshaft Journal to Cylinder Block Bore	Oil Clearance	0.050 to 0.091 mm 0.0020 to 0.0035 in.	0.15 mm 0.0059 in.	
	• Camshaft Journal	O.D.	35.934 to 35.950 mm 1.4147 to 1.4153 in.	–
	• Cylinder Block Bore	I.D.	36.000 to 36.025 mm 1.4173 to 1.4183 in.	–

Item		Factory Specification	Allowable Limit
Piston Pin Bore	I.D.	22.000 to 22.013 mm 0.86615 to 0.86665 in.	22.03 mm 0.8673 in.
Piston Pin to Small End Bushing	Clearance	0.014 to 0.038 mm 0.00055 to 0.0014 in.	0.15 mm 0.0059 in.
	• Piston Pin O.D.	22.002 to 22.011 mm 0.86622 to 0.86657 in.	–
	• Small End Bushing I.D.	22.025 to 22.040 mm 0.86713 to 0.86771 in.	–
Piston Pin to Small End Bushing (Spare Parts)	Clearance	0.014 to 0.038 mm 0.00056 to 0.0014 in.	0.15 mm 0.0059 in.
	• Small End Bushing I.D.	22.025 to 22.040 mm 0.86713 to 0.86771 in.	–
Piston Ring Gap [D1105, V1505]	• Top Ring	0.20 to 0.35 mm 0.0079 to 0.014 in.	1.20 mm 0.0472 in.
	• Second Ring	0.40 to 0.55 mm 0.016 to 0.021 in.	1.20 mm 0.0472 in.
	• Oil Ring	0.30 to 0.55 mm 0.012 to 0.021 in.	1.25 mm 0.0492 in.
Piston Ring Gap [D1305]	• Top Ring	0.15 to 0.25 mm 0.0059 to 0.0098 in.	1.20 mm 0.0472 in.
	• Second Ring	0.40 to 0.55 mm 0.016 to 0.021 in.	1.20 mm 0.0472 in.
	• Oil Ring	0.25 to 0.45 mm 0.0091 to 0.017 in.	1.25 mm 0.0492 in.
Piston Ring to Piston Ring Groove [D1105, V1505]	• Second Ring Clearance	0.0950 to 0.122 mm 0.00374 to 0.00480 in.	0.2 mm 0.008 in.
	• Oil Ring Clearance	0.020 to 0.060 mm 0.00079 to 0.0023 in.	0.15 mm 0.0059 in.
Piston Ring to Piston Ring Groove [D1305]	• Second Ring Clearance	0.0850 to 0.122 mm 0.00335 to 0.00480 in.	0.2 mm 0.008 in.
	• Oil Ring Clearance	0.02 to 0.06 mm 0.0008 to 0.002 in.	0.15 mm 0.0059 in.
Connecting Rod	Alignment	–	0.05 mm 0.002 in.
Crankshaft	Side Clearance	0.15 to 0.31 mm 0.0059 to 0.012 in.	0.50 mm 0.020 in.
	Alignment	–	0.02 mm 0.0008 in.

Item		Factory Specification	Allowable Limit	
Crankpin to Crankpin Bearing	Oil Clearance	0.029 to 0.091 mm 0.0011 to 0.0036 in.	0.20 mm 0.0079 in.	
	• Crankpin	O.D.	39.959 to 39.975 mm 1.5732 to 1.5738 in.	–
	• Crankpin Bearing	I.D.	40.004 to 40.050 mm 1.573922 to 1.5767 in.	–
Crankshaft to Crankshaft Bearing 1 [D1105, V1505]	Oil Clearance	0.0340 to 0.114 mm 0.00134 to 0.00468 in.	0.20 mm 0.0079 in.	
	• Crankshaft	O.D.	47.934 to 47.950 mm 1.8872 to 1.8877 in.	–
	• Crankshaft Bearing 1	I.D.	47.984 to 48.048 mm 1.8892 to 1.8916 in.	–
Crankshaft to Crankshaft Bearing 1 [D1305]	Oil Clearance	0.0340 to 0.119 mm 0.00134 to 0.00468 in.	0.20 mm 0.0079 in.	
	• Crankshaft	O.D.	51.921 to 51.940 mm 2.0442 to 2.0448 in.	–
	• Crankshaft Bearing 1	I.D.	51.974 to 52.040 mm 2.0463 to 2.0488 in.	–
Crankshaft to Crankshaft Bearing 2 [D1105, V1505]	Oil Clearance	0.034 to 0.095 mm 0.0014 to 0.0037 in.	0.20 mm 0.0079 in.	
	• Crankshaft Journal	O.D.	47.934 to 47.950 mm 1.8872 to 1.8877 in.	–
	• Crankshaft Bearing 2	I.D.	47.984 to 48.029 mm 1.8892 to 1.8909 in.	–
Crankshaft to Crankshaft Bearing 3 [D1105, V1505]	Oil Clearance	0.034 to 0.103 mm 0.00134 to 0.00405 in.	0.20 mm 0.0079 in.	
	• Crankshaft Journal	O.D.	51.921 to 51.940 mm 2.0442 to 2.0448 in.	–
	• Crankshaft Bearing 3	I.D.	51.974 to 52.024 mm 2.0463 to 2.0481 in.	–
Crankshaft to Crankshaft Bearing 2 [D1305]	Oil Clearance	0.0340 to 0.103 mm 0.00134 to 0.00405 in.	0.20 mm 0.0079 in.	
	• Crankshaft Journal	O.D.	51.921 to 51.940 mm 2.0442 to 2.0448 in.	–
	• Crankshaft Bearing 2	I.D.	51.974 to 52.024 mm 2.0463 to 2.0481 in.	–

Item		Factory Specification	Allowable Limit
Crankshaft to Crankshaft Bearing 3 [D1305]	Oil Clearance	0.0340 to 0.103 mm 0.00134 to 0.00405 in.	0.20 mm 0.0079 in.
	• Crankshaft Journal	O.D. 51.921 to 51.940 mm 2.0442 to 2.0448 in.	–
	• Crankshaft Bearing 3	I.D. 51.974 to 52.024 mm 2.0463 to 2.0481 in.	–
Cylinder	I.D.	78.000 to 78.019 mm 3.0709 to 3.0716 in.	78.15 mm 3.077 in.
Cylinder Liner (Oversized)	I.D.	78.500 to 78.519 mm 3.0906 to 3.0912 in.	78.65 mm 3.096 in.

LUBRICATING SYSTEM

Item		Factory Specification	Allowable Limit
Engine Oil Pressure	At Idle Speed	–	49 kPa 0.5 kgf/cm ² 7 psi
	At Rated Speed	196 to 441 kPa 2.0 to 4.5 kgf/cm ² 36 to 64 psi	147 kPa 1.5 kgf/cm ² 27 psi
Inner Rotor to Outer Rotor	Clearance	0.060 to 0.18 mm 0.0024 to 0.0071 in.	–
Outer Rotor to Pump Body	Clearance	0.100 to 0.180 mm 0.00394 to 0.00708 in.	–
Inner Rotor to Cover	Clearance	0.025 to 0.075 mm 0.00099 to 0.0029 in.	–

COOLING SYSTEM

Item		Factory Specification	Allowable Limit
Fan Belt	Tension	7.0 to 9.0 mm 0.28 to 0.35 in.	–
Thermostat	Valve Opening Temperature (At Beginning)	69.5 to 72.5 °C 157.1 to 162.5 °F	–
	Valve Opening Temperature (Opened Completely)	85 °C 185 °F	–
Radiator Cap	Pressure Falling Time	More than 10 seconds for pressure fall from 88 to 59 kPa (from 0.89 to 0.61 kgf/cm ² , from 12 to 8.6 psi)	–
Radiator	Water Leakage Test Pressure	137 kPa 1.4 kgf/cm ² 20 psi	–

FUEL SYSTEM

Item		Factory Specification	Allowable Limit
Injection Pump	Injection Timing [D1105]	0.2837 to 0.3097 rad (16.25 to 17.75 °) after T.D.C.	–
	Injection Timing [D1305]	0.2662 to 0.2923 rad (15.25 to 16.75 °) before T.D.C.	–
	Injection Timing [V1505]	0.2837 to 0.3097 rad (16.25 to 17.75 °) after T.D.C.	–
Pump Element	Fuel Tightness	–	13.73 MPa 140 kgf/cm ² 1991 psi
Delivery Valve	Fuel Tightness	10 seconds 13.73 → 12.75 MPa 140 → 130 kgf/cm ² 1991 → 1849 psi	5 seconds 13.73 → 12.75 MPa 140 → 130 kgf/cm ² 1991 → 1849 psi
Injection Nozzle	Injection Pressure	13.73 to 14.71 MPa 140 to 150 kgf/cm ² 1990 to 2130 psi	–
Injection Nozzle Valve Seat	Valve Seat Tightness	No fuel leak at 12.75 MPa 130 kgf/cm ² 1849 psi	–

9Y1210982ENS0002US0

3. TIGHTENING TORQUES

Tightening torque of screws, bolts and nuts on the table below are specially specified. (For general use screws, bolts and nuts: See page G-10.)

■ NOTE

- In removing and applying the bolts and nuts marked with "*", a pneumatic wrench or similar pneumatic tool, if employed, must be used with enough care not to get them seized.
- For "*" marked screws, bolts and nuts on the table, apply engine oil to their threads and seats before tightening.
- The letter "M" in Size × Pitch means that the screw, bolt or nut dimension stands for metric. The size is the nominal outside diameter in mm of the threads. The pitch is the nominal distance in mm between two threads.

9Y1210982ENS0003US0

[1] TRACTOR SECTION

Item	N·m	kgf·m	lbf·ft
Power steering hose 2	24 to 28	2.5 to 2.8	18 to 20
Steering wheel mounting nut	20 to 40	2.1 to 4.0	15 to 29
Engine mounting screw	59 to 69	6.1 to 7.0	44 to 50

9Y1210982ENS0004US0

[2] ENGINE SECTION

Item	Size × Pitch	N·m	kgf·m	lbf·ft
Oil pressure switch	–	15 to 19	1.5 to 2.0	11 to 14
Nozzle holder	–	35 to 39	3.5 to 4.0	26 to 28
Overflow pipe nut	–	35 to 39	3.5 to 4.0	26 to 28
Nozzle holder assembly	–	49 to 68	5.0 to 7.0	36 to 50
*Cylinder head cover nuts [D1105, V1505]	M7 × 1.0	7 to 8	0.7 to 0.9	5 to 6
*Cylinder head cover nuts [D1305]	M7 × 1.0	9.81 to 11.2	1.00 to 1.15	7.24 to 8.31
Injection pipe retaining nuts	M12 × 1.5	25 to 34	2.5 to 3.5	18 to 25
*Rocker arm bracket nuts	M7 × 1.0	22 to 26	2.2 to 2.7	16 to 19
*Cylinder head screw	M10 × 1.25	64 to 68	6.5 to 7.0	47 to 50
*Fan drive pulley screw	M14 × 1.5	236 to 245	24.0 to 25.0	174 to 180
Idle gear 2 lock nut	–	25 to 29	2.5 to 3.0	18 to 21
Idle gear 2 bearing nut	–	35 to 39	3.5 to 4.0	26 to 28
*Connecting rod screw	M8 × 1.0	42 to 46	4.2 to 4.7	31 to 33
*Flywheel screw	M10 × 1.25	53.9 to 58.8	5.5 to 6.0	39.8 to 43.4
*Bearing case cover screws	M6 × 1.0	9.81 to 11.2	1.00 to 1.15	7.24 to 8.31
*Main bearing case screw 2	M9 × 1.25	49 to 53	5.0 to 5.5	37 to 39
*Main bearing case screw 1	M8 × 1.25	30 to 34	3.0 to 3.5	22 to 25

9Y1210982ENS0005US0

4. CHECKING, DISASSEMBLING AND SERVICING

[1] CHECKING AND ADJUSTING

(1) Engine Body

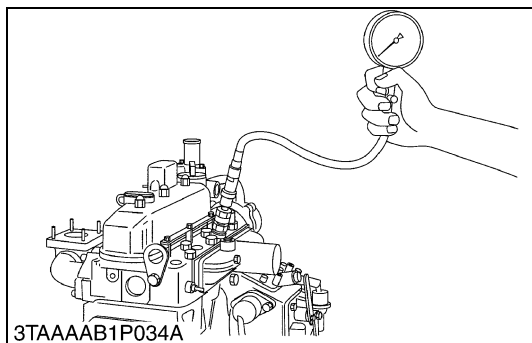

Compression Pressure

1. Operate the engine until it is warmed up.
2. Stop the engine.
3. Remove the air cleaner, the muffler and all glow plugs (or nozzles).
4. Set a compression tester with the adaptor to the glow plug hole (or nozzle hole).
Nozzle Hole: Adaptor **H**
Glow Plug Hole: Adaptor **L**
5. After making sure that the stop lever is set at the stop position (non-injection), operate the engine with the starter and measure the compression pressure.
6. Repeat steps 4 and 5 for each cylinder.
7. If the measurement is below the allowable limit, apply a small amount of oil to the cylinder wall through the glow plug hole (or nozzle hole) and measure the compression pressure again.
8. If the compression pressure is still less than the allowable limit, check the top clearance, valve clearance and cylinder head.
9. If the compression pressure increases after applying oil, check the cylinder wall and piston rings.

■ NOTE

- Check the compression pressure with the specified valve clearance.
- Always use a fully charged battery for performing this test.
- Variances in cylinder compression values should be under 10 %.

Compression pressure	Factory specification	3.73 to 4.11 MPa 38.0 to 42.0 kgf/cm ² 541 to 597 psi
	Allowable limit	2.26 MPa 23.0 kgf/cm ² 327 psi

9Y1210982ENS0006US0

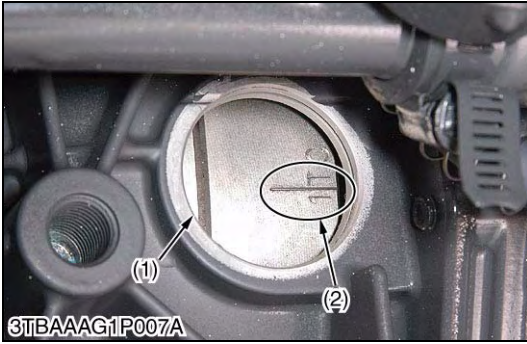
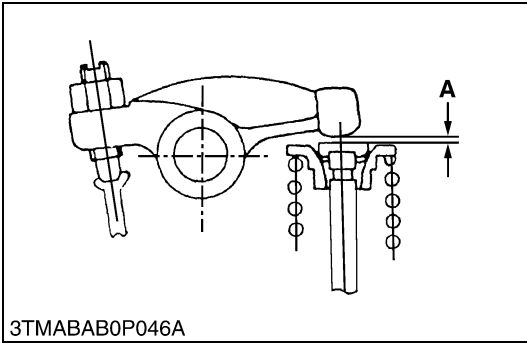
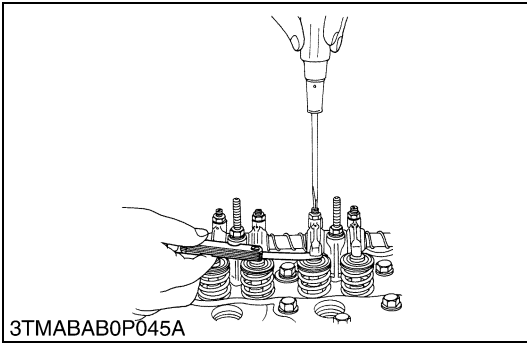

Valve Clearance 1 (ROPS Model)

■ **IMPORTANT**

- **Valve clearance must be checked and adjusted when engine is cold.**
1. Remove the head cover, the glow plugs and the timing window cover on the clutch housing.
 2. Align the "1TC" mark line on the flywheel and center of timing window so that the No. 1 piston comes to the compression top dead center.
 3. Check the following valve clearance marked with "☆" using a feeler gauge.
 4. If the clearance is not within the factory specifications, adjust with the adjusting screw.

Valve clearance	Factory specification	0.145 to 0.185 mm 0.0057 to 0.0073 in.
-----------------	-----------------------	---

■ **NOTE**

- The "TC" marking line on the flywheel is just for No. 1 cylinder. There is no "TC" marking for the other cylinders.
- No. 1 piston comes to the T.D.C. position when the "TC" marking line is aligned with center of timing window on front case. Turn the flywheel 0.26 rad (15 °) clockwise and counterclockwise to see if the piston is at the compression top dead center or the overlap position. Now referring to the table below, readjust the valve clearance. (The piston is at the compression top dead center when both the IN. and EX. valves do not move; it is at the overlap position when both the valves move.)
- Finally turn the flywheel 6.28 rad (360 °) and align the "TC" marking line and the center of timing window. Adjust all the other valve clearance as required.
- After turning the flywheel counterclockwise twice or three times, recheck the valve clearance, firmly tighten the lock nut of the adjusting screw.

Adjustable cylinder location of piston		Number of cylinders Valve arrangement			
		3-cylinder		4-cylinder	
		IN.	EX.	IN.	EX.
When No. 1 piston comes to compression top dead center	No. 1	☆	☆	☆	☆
	No. 2		☆	☆	
	No. 3	☆			☆
	No. 4				
When No. 1 piston comes to overlap position	No. 1				
	No. 2	☆			☆
	No. 3		☆	☆	
	No. 4			☆	☆

☆: Valve clearance is adjustable.

- (1) Timing Window
- (2) TC Mark Line

A: Valve Clearance

9Y1210982ENS0007US0

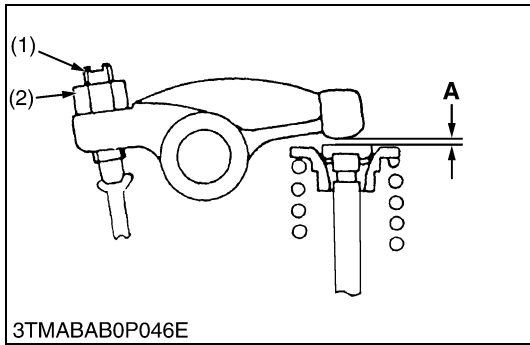
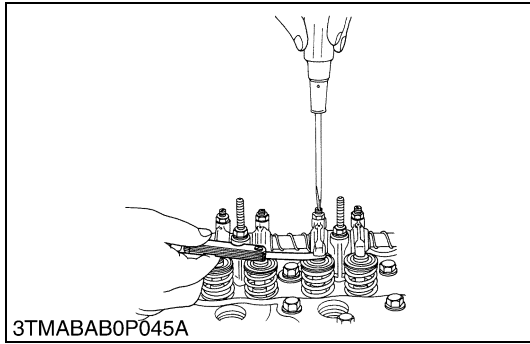

Valve Clearance 2 (CABIN Model)

■ **IMPORTANT**

- **Valve clearance must be checked and adjusted when engine is cold.**
1. Remove the head cover and the glow plugs.
 2. Check and adjust the valve clearance at the both valves compression top dead center.
 3. If the clearance is not within the factory specifications, adjust with the adjusting screw.
 - Firing order
 - 3-cylinder: 1 → 2 → 3
 - 4-cylinder: 1 → 3 → 4 → 2
 - Check and adjust the valve clearance following the firing order shown above.

Valve clearance	Factory specification	0.145 to 0.185 mm 0.0057 to 0.0073 in.
-----------------	-----------------------	---

- (1) Adjusting Screw
- (2) Lock Nut

A: Valve Clearance

9Y1210982ENS0008US0

(2) Lubricating System

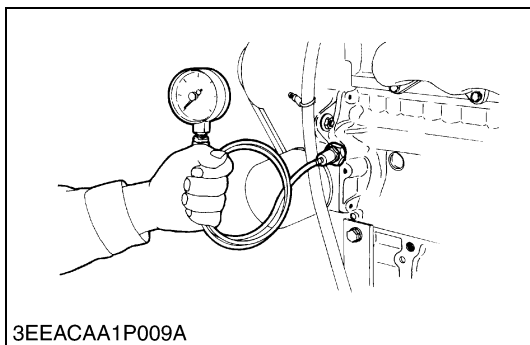

Engine Oil Pressure

1. Remove the engine oil pressure switch, and set an oil pressure tester.
2. Start the engine. After warming up, measure the oil pressure of both idling and rated speeds.
3. If the oil pressure is less than the allowable limit, check the following.
 - Engine oil insufficient
 - Oil pump damaged
 - Oil strainer clogged
 - Oil filter cartridge clogged
 - Oil gallery clogged
 - Excessive oil clearance
 - Foreign matter in the relief valve

Engine oil pressure	At idle speed	Allowable limit	49 kPa 0.5 kgf/cm ² 7 psi
	At rated speed	Factory specification	196 to 441 kPa 2.0 to 4.5 kgf/cm ² 36 to 64 psi
		Allowable limit	147 kPa 1.5 kgf/cm ² 27 psi

(When reassembling)

- After checking the engine oil pressure, tighten the engine oil pressure switch to the specified torque.

Tightening torque	Oil pressure switch	15 to 19 N·m 1.5 to 2.0 kgf·m 11 to 14 lbf·ft
-------------------	---------------------	---

9Y1210982ENS0009US0

(3) Cooling System

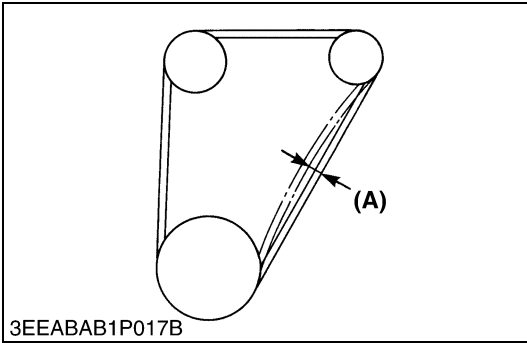

Fan Belt Tension

1. Measure the deflection **(A)**, depressing the belt halfway between the fan drive pulley and alternator pulley at specified force (98 N, 10 kgf, 22 lbf).
2. If the measurement is not within the factory specifications, loosen the alternator mounting screws and relocate the alternator to adjust.

Deflection (A)	Factory specification	7.0 to 9.0 mm 0.28 to 0.35 in.
-----------------------	-----------------------	-----------------------------------

9Y1210982ENS0010US0

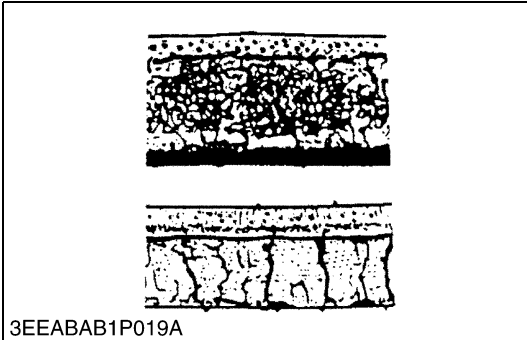

Fan Belt Damage and Wear

1. Check the fan belt for damage.
2. If the fan belt is damaged, replace it.
3. Check if the fan belt is worn and sunk in the pulley groove.
4. If the fan belt is nearly worn out and deeply sunk in the pulley groove, replace it.

(A) Good

(B) Bad

9Y1210982ENS0011US0

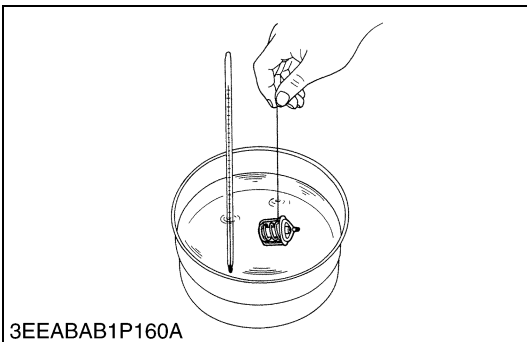
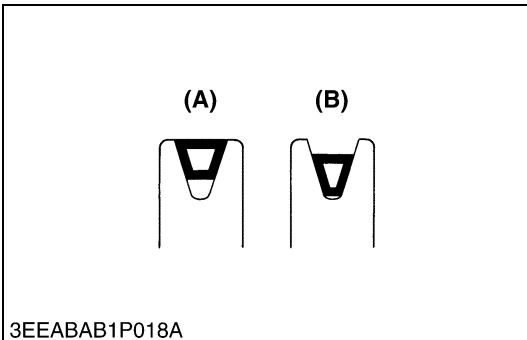

Thermostat Valve Opening Temperature

1. Suspend the thermostat in the water by a string with its end inserted between the valve and seat.
2. Heating the water gradually, read the temperature when the valve opens and leaves the string.
3. Continue heating and read the temperature when the valve opens approx. 8 mm (0.3 in.).
4. If the measurement is not within the factory specifications, replace the thermostat.

Thermostat's valve opening temperature	Factory specification	69.5 to 72.5 °C 157.1 to 162.5 °F
Temperature at which thermostat completely open	Factory specification	85 °C 185 °F

9Y1210982ENS0012US0

CAUTION

- When removing the radiator cap, wait at least ten minutes after the engine has stopped and cooled down. Otherwise, hot water may gush out, scalding nearby people.

9Y1210982ENS0013US0

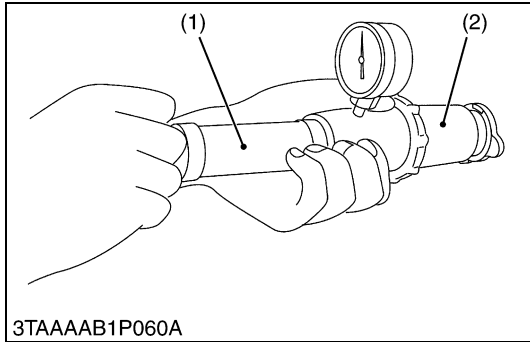

Radiator Cap Air Leakage

1. Set a radiator tester (1) and adaptor (2) on the radiator cap.
2. Apply the specified pressure 88 kPa (0.89 kgf/cm², 12 psi), and measure the time for the pressure to fall to 59 kPa (0.61 kgf/cm², 8.6 psi).
3. If the measurement is less than the factory specification, replace the radiator cap.

Pressure falling time	Factory specification	More than 10 seconds for pressure fall from 88 to 59 kPa (from 0.89 to 0.61 kgf/cm ² , from 12 to 8.6 psi)
-----------------------	-----------------------	---

(1) Radiator Tester

(2) Adaptor

9Y1210982ENS0014US0

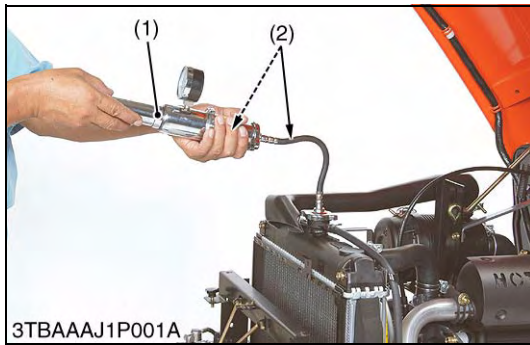

Radiator Water Leakage

1. Pour a specified amount of water into the radiator.
2. Set a radiator tester (1) and an adaptor (2) and raise the water pressure to the specified pressure.
3. Check the radiator for water leaks.
4. For water leak from the pinhole, repair with the radiator cement. When water leak is excessive, replace the radiator.

Radiator water leakage test pressure	Factory specification	137 kPa 1.4 kgf/cm ² 20 psi
--------------------------------------	-----------------------	--

(1) Radiator Tester

(2) Adaptor

9Y1210982ENS0015US0

(4) Fuel System

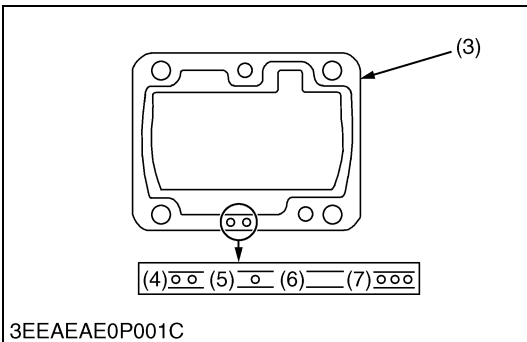
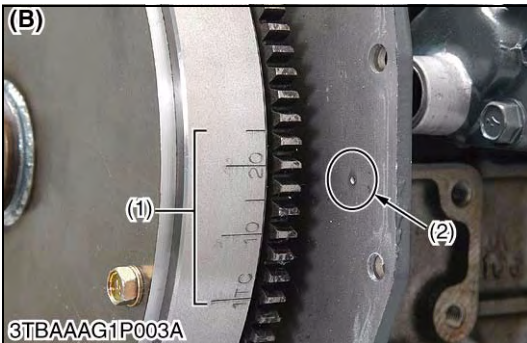

Injection Timing

1. Remove the injection pipes.
2. Remove the engine stop solenoid.
3. Turn the flywheel counterclockwise (facing the flywheel) until fuel flows from the delivery valve holder.
4. Continue to turn the flywheel slowly, and stop it as soon as the fuel level at the tip of the delivery valve holder begins to increase.
5. Check to see if the timing angle lines on the flywheel is aligned with the alignment mark (2).
6. If the injection timing is out of adjustment, readjust the timing with shims.

Injection timing [D1105]	Factory specification	0.2837 to 0.3097 rad (16.25 to 17.75 °) after T.D.C.
Injection timing [D1305]	Factory specification	0.2662 to 0.2923 rad (15.25 to 16.75 °) before T.D.C.
Injection timing [V1505]	Factory specification	0.2837 to 0.3097 rad (16.25 to 17.75 °) before T.D.C.

NOTE

- The sealant is applied to both sides of the shim (soft metal gasket shim). The liquid gasket is not required for assembling.
- Shims are available in thickness of 0.20 mm (0.0079 in.), 0.25 mm (0.0098 in.), 0.30 mm (0.012 in.), 0.35 mm (0.014 in.) and 0.175 mm (0.00689 in.). Combine these shims for adjustments.
- Addition or reduction of shim (0.025 mm, 0.00098 in.) delays or advances the injection timing by approx. 0.0044 rad (0.25 °).
- In disassembling and replacing the injection pump, be sure to use the same number of new shims with the same thickness.
- Refer to figure below to check the thickness of the shims.

- | | |
|--|--|
| (1) Timing Line | (A) Engine mounted on the tractor (ROPS model) |
| (2) Alignment Mark | (B) Engine only (ROPS and CABIN model) |
| (3) Shim (Soft Metal Gasket Shim) | |
| (4) Two-holes: 0.20 mm (0.0079 in.)
Two-holes: 0.175 mm (0.00689 in.) | |
| (5) One-hole: 0.25 mm (0.0098 in.) | |
| (6) Without hole: 0.30 mm (0.012 in.) | |
| (7) Three-holes: 0.35 mm (0.014 in.) | |

9Y1210982ENS0016US0

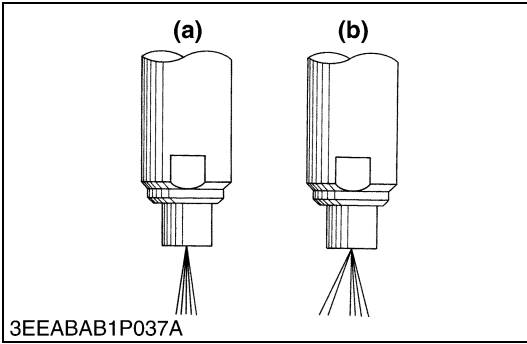

Nozzle Spraying Condition

CAUTION

- Check the injection pressure and condition after you make sure that there is nobody standing in the direction the fume goes.
- If the fume from the nozzle directly injects the human body, cells may be destroyed and blood poisoning may be caused.

1. Set the injection nozzle to a nozzle tester, and check the nozzle spraying condition.
2. If the spraying condition is damaged, replace the nozzle piece.

(a) Good

(b) Bad

9Y1210982ENS0019US0

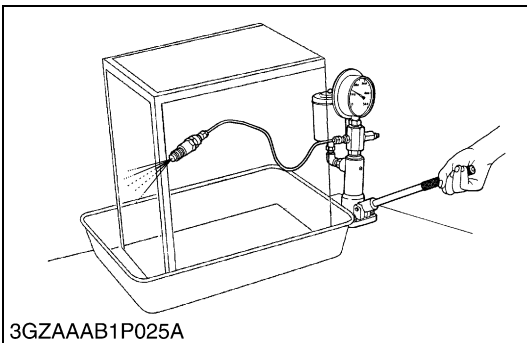

Fuel Injection Pressure

1. Set the injection nozzle to a nozzle tester.
2. Slowly move the tester handle to measure the pressure at which fuel begins jetting out from the nozzle.
3. If the measurement is not within the factory specifications, replace the adjusting washer (1) in the nozzle holder to adjust it.

Fuel injection pressure	Factory specification	13.73 to 14.71 MPa 140 to 150 kgf/cm ² 1990 to 2130 psi
-------------------------	-----------------------	--

(Reference)

- Pressure variation with 0.01 mm (0.0004 in.) difference of adjusting washer thickness:
Approx. 235 kPa (2.4 kgf/cm², 34 psi)

(1) Adjusting Washer

9Y1210982ENS0020US0

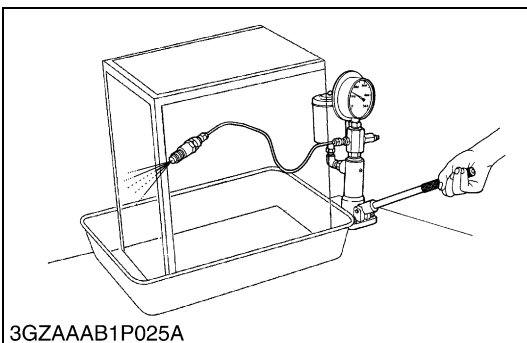
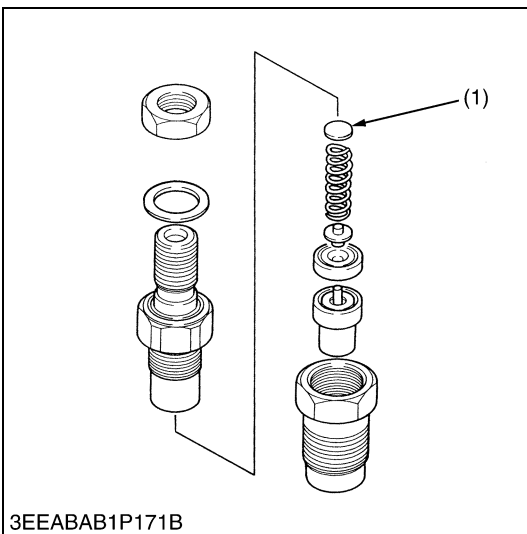

Valve Seat Tightness

1. Set the injection nozzle to a nozzle tester.
2. Raise the fuel pressure, and keep at 12.75 MPa (130 kgf/cm², 1849 psi) for 10 seconds.
3. If any fuel leak is found, replace the nozzle piece.

Valve seat tightness	Factory specification	No fuel leak at 12.75 MPa 130 kgf/cm ² 1849 psi
----------------------	-----------------------	---

9Y1210982ENS0021US0

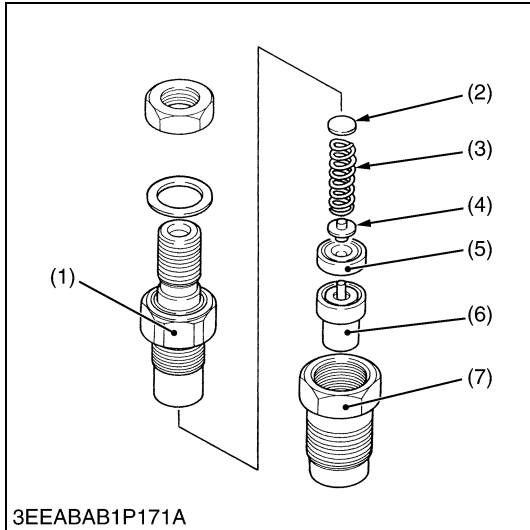

Nozzle Holder

1. Secure the nozzle retaining nut (7) with a vise.
2. Remove the nozzle holder (1), and take out parts inside.

(When reassembling)

- Assemble the nozzle in clean fuel oil.
- Install the push rod (4), noting its direction.
- After assembling the nozzle, be sure to adjust the fuel injection pressure.

Tightening torque	Nozzle holder	35 to 39 N·m 3.5 to 4.0 kgf·m 26 to 28 lbf·ft
	Overflow pipe nut	35 to 39 N·m 3.5 to 4.0 kgf·m 26 to 28 lbf·ft
	Nozzle holder assembly	49 to 68 N·m 5.0 to 7.0 kgf·m 36 to 50 lbf·ft

- | | |
|----------------------|--------------------------|
| (1) Nozzle Holder | (5) Distance Piece |
| (2) Adjusting Washer | (6) Nozzle Piece |
| (3) Nozzle Spring | (7) Nozzle Retaining Nut |
| (4) Push Rod | |

9Y1210982ENS0022US0

[2] PREPARATION

(1) Draining Lubricants and Coolant

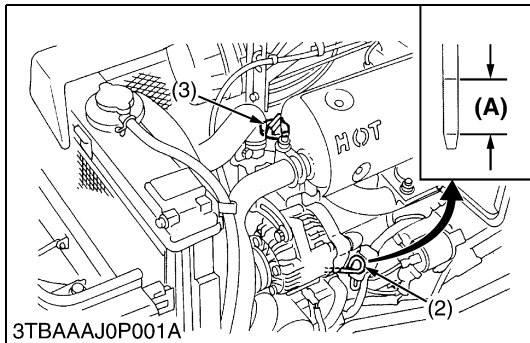

Draining Engine Oil

CAUTION

- Before changing oil, be sure to stop the engine.
1. Start and warm up the engine for approx. 5 minutes.
 2. Place an oil pan underneath the engine.
 3. To drain the used oil, remove the drain plug (1) at the bottom of the engine and drain the oil completely.
 4. Screw in the drain plug (1).
 5. Fill new oil up to upper line on the dipstick (2).

IMPORTANT

- When using an oil of different manufacture or viscosity from the previous one, remove all of the old oil.
 - Never mix two different types of oil.
 - Use the proper SAE Engine Oil according to ambient temperatures.
- Refer to G-8.**

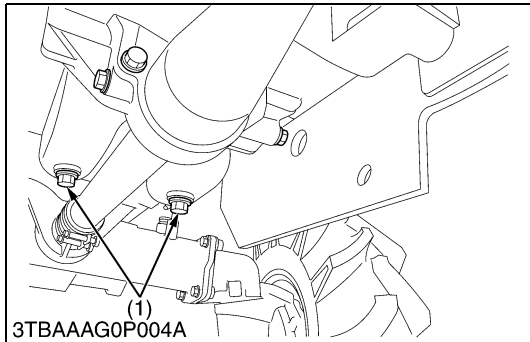

Engine oil capacity	B2050, B2350	3.1 L 3.3 U.S.qts 2.8 Imp.qts
	B2650, B3150	4.0 L 4.2 U.S.qts 3.5 Imp.qts

- | | |
|--------------------|---|
| (1) Drain Plug | (A) Oil level is acceptable within this range. |
| (2) Dipstick | |
| (3) Oil Inlet Plug | |

9Y1210982ENS0023US0

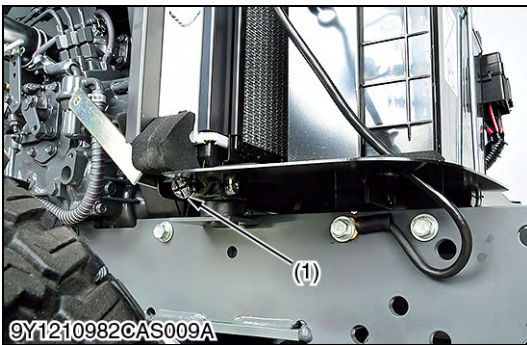
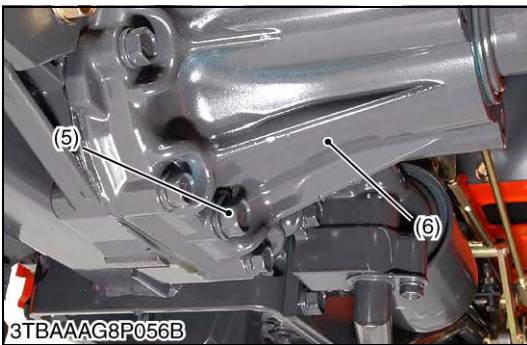
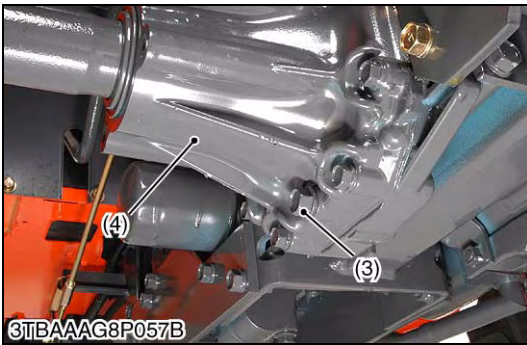

Draining Transmission Fluid

⚠ CAUTION

• Stop the engine before checking and changing the transmission fluid.

1. Place the oil pan under the tractor.
2. Remove the drain plugs (1), (3), (5) at the mid-PTO shaft and at the bottom of the rear axle cases (4), (6).
3. Drain the transmission fluid.
4. After draining the transmission fluid, reinstall the drain plugs (1), (3), (5).

■ IMPORTANT

• Use only KUBOTA UDT oil. Use of other oils may damage the transmission or hydraulic system. Refer to G-8.

• Never work the tractor immediately after changing the transmission oil. Keep the engine at medium speed for a few minutes to prevent damage to the transmission.

• Do not mix different brands oil together.

Transmission fluid capacity	B2050, B2350, B2650 Manual transmission	16.5 L 4.4 U.S.gals 3.6 Imp.gals
	B2350HST B2650HST B3150HST	17 L 4.5 U.S.gals 3.7 Imp.gals

- | | |
|-------------------|---------------------------|
| (1) Drain Plug | (4) Rear Axle Case (L.H.) |
| (2) Mid-PTO Shaft | (5) Drain Plug |
| (3) Drain Plug | (6) Rear Axle Case (R.H.) |

9Y1210982ENS0024US0

Draining Coolant

⚠ CAUTION

• Never remove the radiator cap until coolant temperature is well below its boiling point. Then loosen cap slightly to the stop to relieve any excess pressure before removing cap completely.

1. Stop the engine and let cool down.
2. To drain the coolant, turn the drain plug (1) counterclockwise.
3. Remove the radiator cap to completely drain the coolant.
4. After all coolant is drained, reinstall the radiator drain plug.

(When reassembling)

Coolant	Capacity	4.3 L 4.5 U.S.qts 3.8 Imp.qts
---------	----------	-------------------------------------

- (1) Drain Plug

9Y1210982CAS0076US0

(2) Separating Engine from Clutch Housing (CABIN)



Bonnet

1. Open the bonnet (1) and disconnect the battery negative cable.
2. Disconnect the connector for head light and remove the clamp (2).
3. Remove the snap pin (3).
4. Remove the bonnet (1) and side cover.

- | | |
|------------|--------------|
| (1) Bonnet | (3) Snap Pin |
| (2) Clamp | |

9Y1210982ENS0113US0

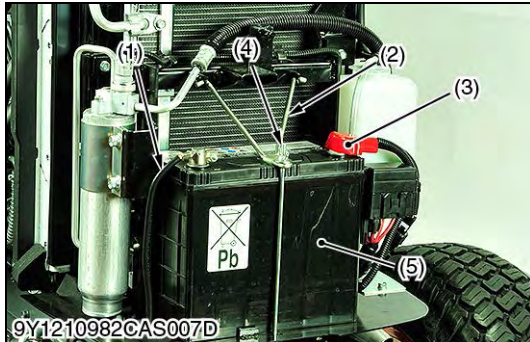

Removing Battery

1. Removing the wing nut (4).
2. Remove the battery retainer (2).
3. Disconnect the battery negative cable (1) from the battery (5).
4. Disconnect the battery positive cable (3) from the battery (5).
5. Remove the battery (5).

(When reassembling)

- Connect the battery positive cable first.
- Connect the battery negative cable second.

- | | |
|----------------------------|--------------|
| (1) Battery Negative Cable | (4) Wing Nut |
| (2) Battery Retainer | (5) Battery |
| (3) Battery Positive Cable | |

9Y1210982ENS0026US0

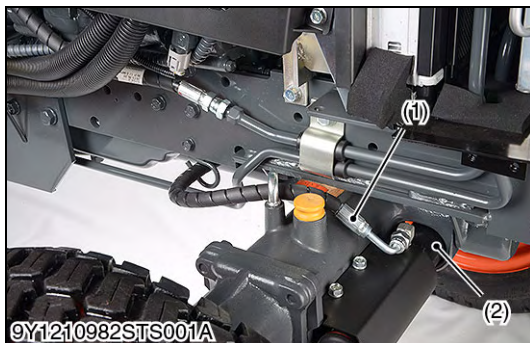

Hydraulic Hoses from Power Steering Cylinder

1. Disconnect the hydraulic hoses (1), (3) from the power steering cylinder (2).
2. Removing the snap pin (4) and disconnect the bi-speed rod (5).

- | | |
|-----------------------------|------------------|
| (1) Hydraulic Hose (R.H.) | (4) Snap Pin |
| (2) Power Steering Cylinder | (5) Bi-Speed Rod |
| (3) Hydraulic Hose (L.H.) | |

[A] Bi-Speed Turn Model

9Y1210982CLS0007US0

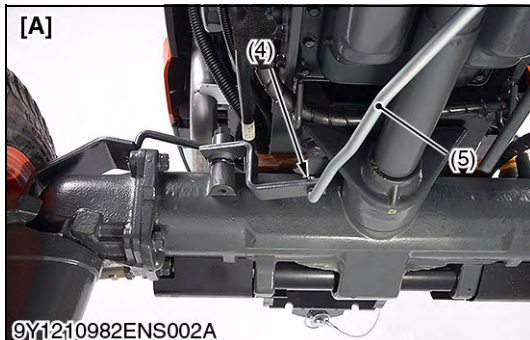
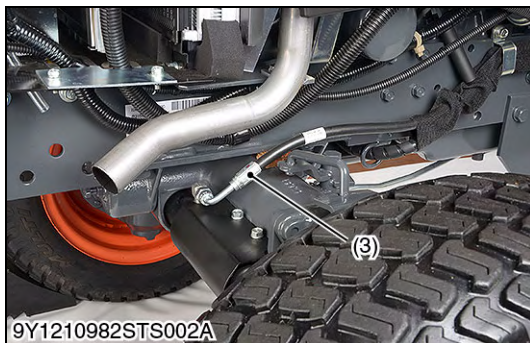

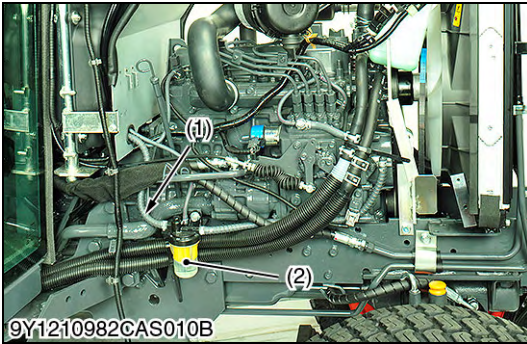

Fuel

1. Disconnect the fuel hose (1) from the fuel filter (2).
2. Drain the fuel to the fuel tank completely.

- (1) Fuel Hose (from Fuel Tank) (2) Fuel Filter

9Y1210982ENS0114US0

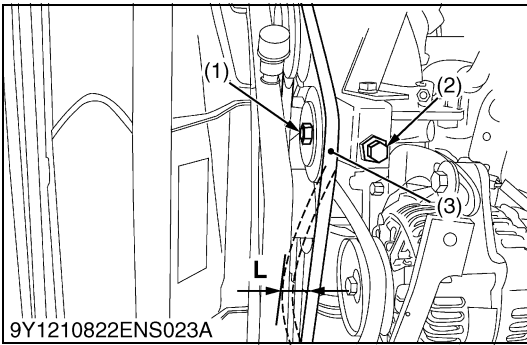

Compressor, Condenser and Receiver

1. Loosen the tension pulley mounting nut (1) and turn the adjusting bolt (2) counterclockwise then remove the air conditioner belt (3).
2. Disconnect the 1P connector (4) from the compressor.
3. Remove the compressor mounting bracket (5) with compressor.
4. Disconnect the connector (6) from the receiver.
5. Remove the condenser mounting bolts (7).
6. Remove the battery bracket mounting bolts (8) and plate (9).
7. Remove the condenser (10) and receiver (12) with battery bracket to the left (viewed from the back of tractor).
8. Remove the compressor (10) and the condenser (11) with the receiver (12) connecting with air-conditioner hose together.

(When reassembling)

- Be careful not to damage the condenser fin.
- After reassembling the compressor, be sure to adjust the air-conditioner belt tension.

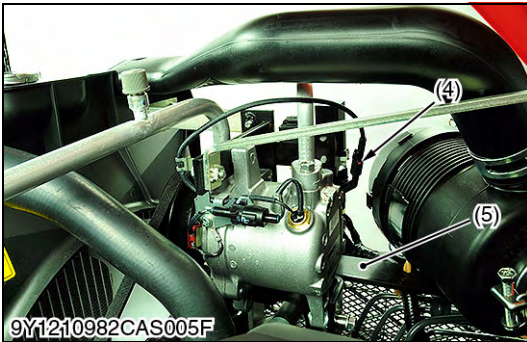

Proper deflection: Air-conditioner belt tension	10 to 12 mm (0.40 to 0.47 in.) when the belt is pressed (98 N (10 kgf, 22 lbf)) in the middle of the span.
--	--

NOTE

- **When remove the compressor, condenser and receiver, be careful not to damage the hose bind (13).**

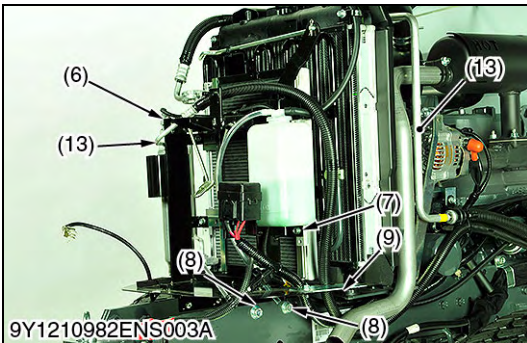

- | | |
|---------------------------------|-----------------------------------|
| (1) Tension Pulley Mounting Nut | (8) Battery Bracket Mounting Bolt |
| (2) Adjusting Bolt | (9) Plate |
| (3) Air Conditioner Belt | (10) Compressor |
| (4) 1P Connector | (11) Condenser |
| (5) Compressor Mounting Bracket | (12) Receiver |
| (6) Connector | (13) Hose Bind |
| (7) Condenser Mounting Bolt | |

9Y1210982ENS0115US0

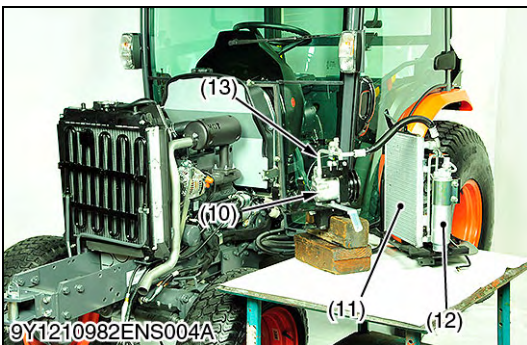

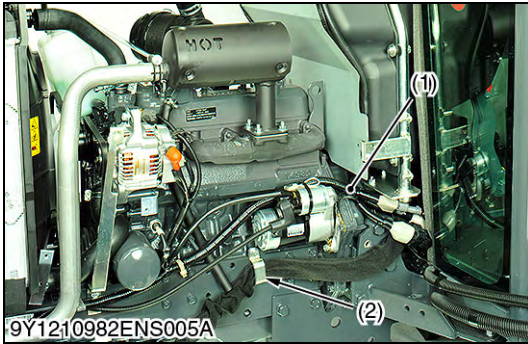

Wiring Harness and Clamp (Left Side)

1. Disconnect the wiring harness (1) from cabin side wiring harness, engine, alternator and starter.
2. Remove the clamp (2).

(1) Wiring Harness (2) Clamp

9Y1210982ENS0116US0

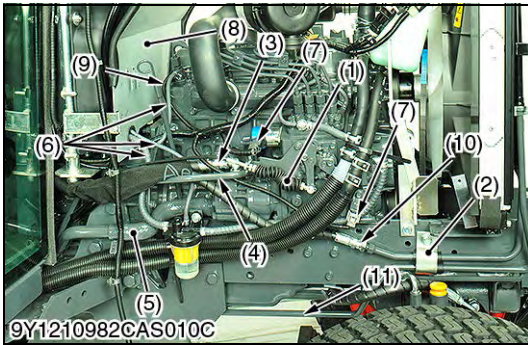

Accelerator Rod, Power Steering Hose, Fuel Hoses, Connectors and Others (Right Side)

1. Disconnect the accelerator rod (1).
2. Remove the clamp (2).
3. Disconnect the power steering hose (3), hydraulic delivery pipe (4) and hydraulic inlet hose (5).
4. Disconnect the fuel hoses (6).
5. Disconnect the connectors (7) and glow plug harness (9).
6. Remove the shuttle plate (8).
7. Disconnect the power steering hose 2 (10) and pipe (11) at Bi-speed case side.

Tightening torque	Power steering hose 2	24 to 28 N·m 2.5 to 2.8 kgf·m 18 to 20 lbf·ft
-------------------	-----------------------	---

(1) Accelerator Rod (7) Connector
 (2) Clamp (8) Shuttle Plate
 (3) Power Steering Hose 1 (9) Glow Plug Harness
 (4) Hydraulic Delivery Pipe (10) Power Steering Hose 2
 (5) Hydraulic Inlet Hose (11) Pipe
 (6) Fuel Hose

9Y1210982ENS0117US0

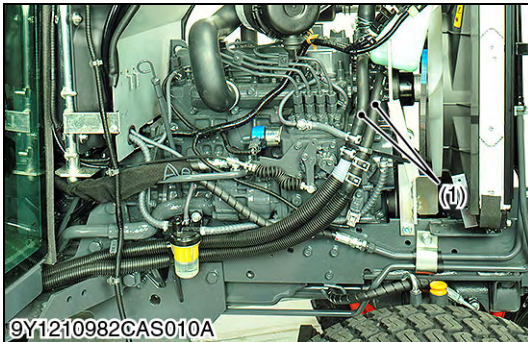
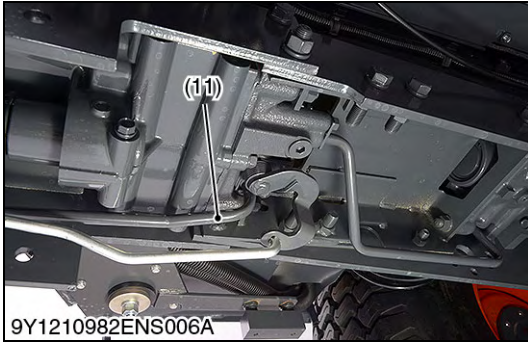

Heater Hose

1. Disconnect the heater hoses (1), and then reconnect their hoses to make loop.

NOTE

- Put a mark to the each heater hoses before disconnecting.

(1) Heater Hose

9Y1210982TRS0009US0



Separating Engine from Clutch Housing

1. Remove the engine screws and nuts, and separate the engine from clutch housing.

(When reassembling)

- Apply molybdenum disulfide (Three Bond 1901 or equivalent) to the splines of the plate boss.
- Apply liquid gasket (Three Bond 1141, 1211 or equivalent) to joint face of the engine and clutch housing, after eliminating the water, oil and stuck liquid gasket.

9Y1210982ENS0118US0

(3) Separating Engine from Front Axle Frame (CABIN)

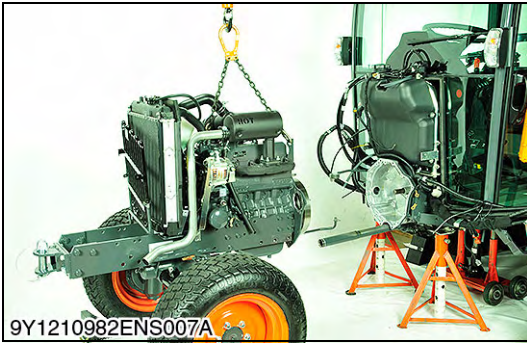

9Y1210982ENS007A

Separating Engine from Front Axle Frame

■ **NOTE**

- When you replace the engine with new one, please record the serial number of new engine and the parts number which is incorporate with its new engine.
1. Remove the engine and front axle frame mounting screw and separate the engine from the front axle frame.

Tightening torque	Engine mounting screw	59 to 69 N·m 6.1 to 7.0 kgf·m 44 to 50 lbf·ft
-------------------	-----------------------	---

9Y1210982ENS0119US0

(4) Separating Engine from Clutch Housing (ROPS)



9Y1210982ENS008A

Bonnet, Side Cover and Battery Cord

1. Open the bonnet (1).
2. Disconnect the battery negative cord.
3. Disconnect the head light connectors and remove the bonnet (1) side covers (2).

■ **NOTE**

- When disconnecting the battery cords, disconnect the grounding cord first. When connecting, positive cord first.

- | | |
|----------------|-------------|
| (1) Bonnet | (3) Battery |
| (2) Side Cover | |

9Y1210982CLS0006US0



9Y1210982STS001A

Hydraulic Hoses from Power Steering Cylinder

1. Disconnect the hydraulic hoses (1), (3) from the power steering cylinder (2).
2. Removing the snap pin (4) and disconnect the bi-speed rod (5).

- | | |
|-----------------------------|-------------------------|
| (1) Hydraulic Hose (R.H.) | [A] Bi-Speed Turn Model |
| (2) Power Steering Cylinder | |
| (3) Hydraulic Hose (L.H.) | |
| (4) Snap Pin | |
| (5) Bi-Speed Rod | |

9Y1210982CLS0007US0

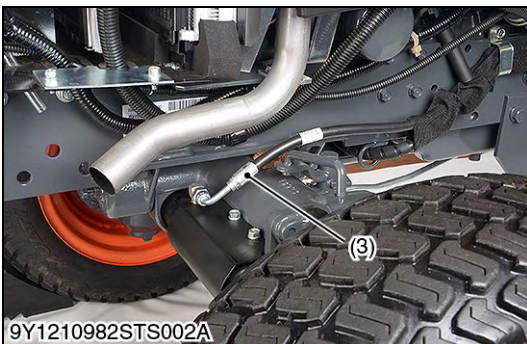

9Y1210982STS002A

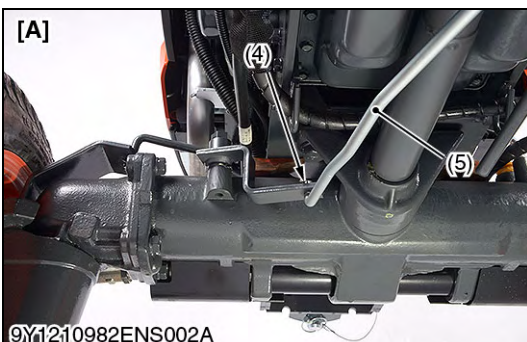

9Y1210982ENS002A

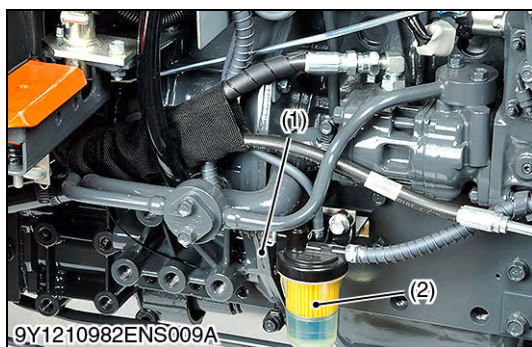

Fuel

1. Disconnect the fuel hose (1) from the fuel filter (2).
2. Drain the fuel to the fuel tank completely.

(1) Fuel Hose (from Fuel Tank) (2) Fuel Filter

9Y1210982CLS0008US0

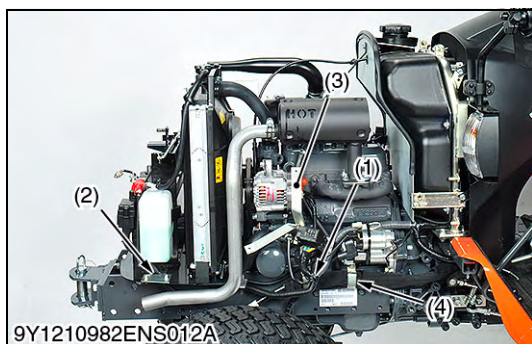

Wiring Harness, Plate, Stay and Clamp (Left Side)

1. Disconnect the wiring harness (1) from battery, alternator, engine and starter.
2. Remove the plate (2).
3. Remove the stay (3) and clamp (4).

(1) Wiring Harness (3) Stay
 (2) Plate (4) Clamp

9Y1210982CLS0010US0

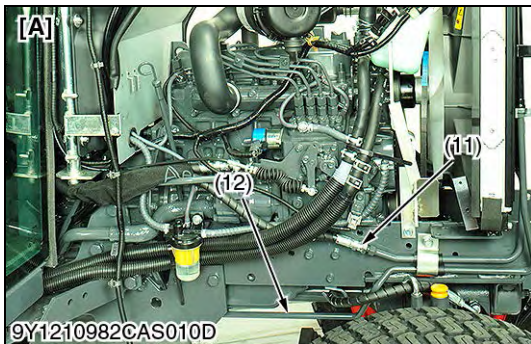
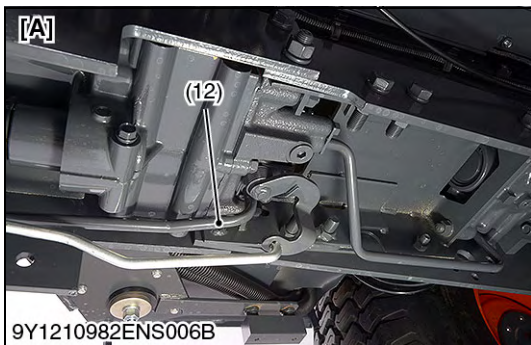
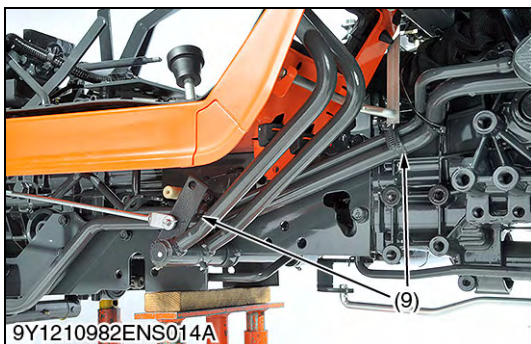
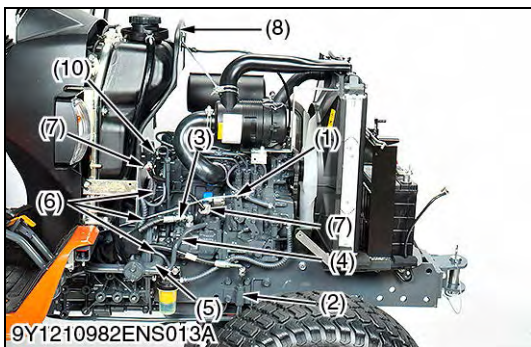

Accelerator Rod, Power Steering Hose, Fuel Hoses, Connectors and Others (Right Side)

1. Disconnect the accelerator rod (1).
2. Remove the clamp (2). In case HST model, disconnect the power steering hose 2 (11) and pipe (12) at Bi-speed case side.
3. Disconnect the power steering hose (3), hydraulic delivery pipe (4) and hydraulic inlet hose (5).
4. Disconnect the fuel hoses (6).
5. Disconnect the connectors (7) and glow plug harness (10).
6. Remove the shuttle plate (8).
7. Disconnect the clamp (9).

Tightening torque	Power steering hose 2	24 to 28 N·m 2.5 to 2.8 kgf·m 18 to 20 lbf·ft
-------------------	-----------------------	---

- | | |
|-----------------------------|----------------------------|
| (1) Accelerator Rod | (8) Shuttle Plate |
| (2) Clamp | (9) Clamp |
| (3) Power Steering Hose 1 | (10) Glow Plug Harness |
| (4) Hydraulic Delivery Pipe | (11) Power Steering Hose 2 |
| (5) Hydraulic Inlet Hose | (12) Pipe |
| (6) Fuel Hose | |
| (7) Connector | |
- [A] HST Model

9Y1210982ENS0120US0



Steering Wheel, Meter Panel, Shuttle Lever and Panel Lower Cover

1. Remove the steering wheel cap.
2. Remove the steering wheel mounting nut.
3. Remove the steering wheel with a steering wheel puller (Code No. 07916-51090).
4. Remove the shuttle lever (2). (If equipped)
5. Disconnect the wiring harness connector of key switch.
6. Remove the panel lower cover (1).
7. Disconnect the hour meter cable (3).

(When reassembling)

- Tighten the steering wheel mounting nut securely.

Tightening torque	Steering wheel mounting nut	20 to 40 N·m 2.1 to 4.0 kgf·m 15 to 29 lbf·ft
-------------------	-----------------------------	---

- (1) Panel Lower Cover
(2) Shuttle Lever

- (3) Hour Meter Cable

9Y1210982CLS0009US0

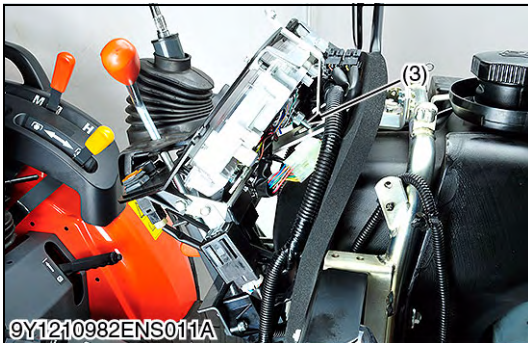

Separating Clutch Housing

1. Support the transmission with a disassembling stand.
2. Hook the engine with a hoist.
3. Remove the docking bolts and nuts between the engine and the front case.

(When reassembling)

- Align the spline between the front wheel drive shaft and the coupling securely.
- Tighten the docking bolts between the engine and the front case securely.
- Apply liquid gasket (Three Bond 1206D or equivalent) to the joint face of the engine and the front case.

9Y1210982CLS0014US0

(5) Separating Engine from Front Axle Frame (ROPS)



Separating Engine from Front Axle Frame

NOTE

- When you replace the engine with new one, please record the serial number of new engine and the parts number which is incorporate with its new engine.

1. Remove the engine and front axle frame mounting screw and separate the engine from the front axle frame.

Tightening torque	Engine mounting screw	59 to 69 N·m 6.1 to 7.0 kgf·m 44 to 50 lbf·ft
-------------------	-----------------------	---

9Y1210982ENS0121US0

[3] DISASSEMBLING AND ASSEMBLING

(1) External Components

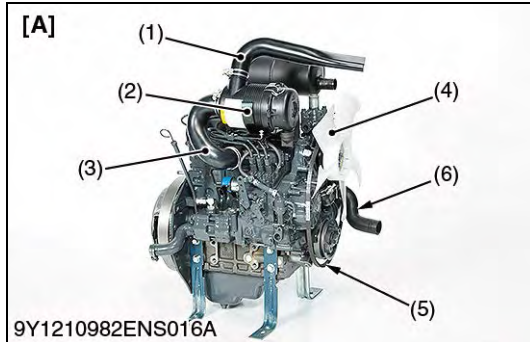

Fan, Water Hose, Fan Belt, Alternator, Muffler, Air Cleaner, Air Cleaner Bracket, Inlet Hose and etc.

1. Remove the external components as shown in the picture.

(When reassembling)

- Check to see that there are no crack on the fan belt surface.

IMPORTANT

- **When installing the fan belt (5), be sure to adjust the fan belt tension.**

Fan belt deflection (A)	Factory specification	7.0 to 9.0 mm 0.28 to 0.35 in.
Air conditioner fan belt deflection	Factory specification	10 to 12 mm 0.40 to 0.47 in.

NOTE

- **When remove the compressor, con denser and receiver, be careful not to damage the hose bind.**

- | | |
|-----------------|------------------------|
| (1) Inlet Hose | (9) Breath Hose |
| (2) Air Cleaner | (10) Clutch Assembly |
| (3) Inlet Hose | (11) Steel Plate |
| (4) Fan | |
| (5) Fan Belt | |
| (6) Water Hose | [A] ROPS Model |
| (7) Muffler | [B] CABIN Model |
| (8) Alternator | (A) Deflection |

9Y1210982ENS0052US0

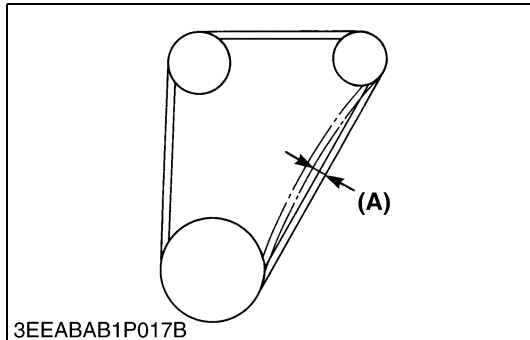
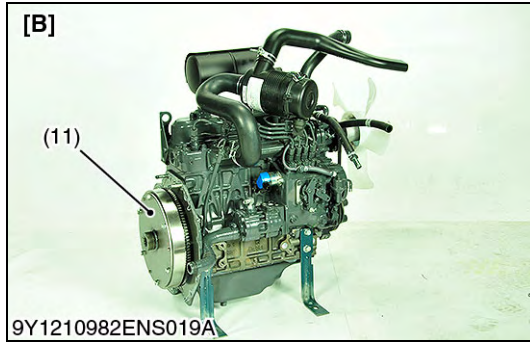
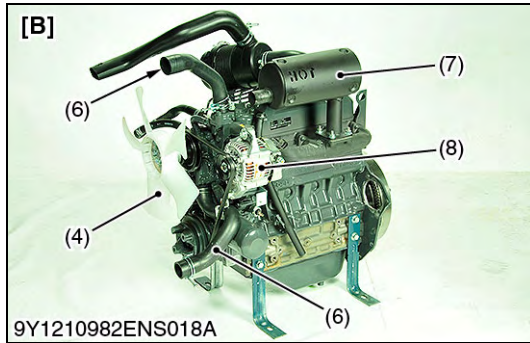
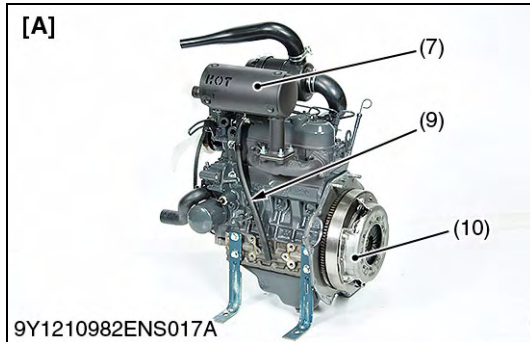

(2) Cylinder Head and Valve and Oil Pan

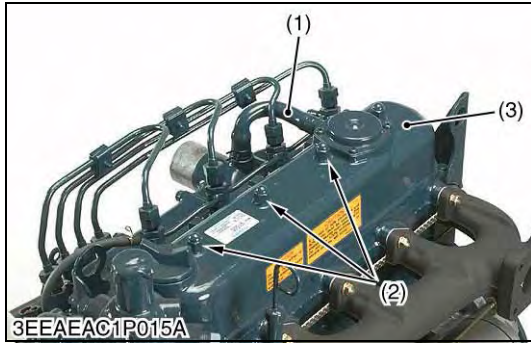

Cylinder Head Cover

1. Disconnect the breather hose (1).
2. Remove the head cover nut (2).
3. Remove the cylinder head cover (3).

(When reassembling)

- Check to see if the cylinder head cover gasket is not damaged.

Tightening torque	Cylinder head cover nut	D1105, V1505	7 to 8 N·m 0.7 to 0.9 kgf·m 5 to 6 lbf·ft
		D1305	9.81 to 11.2 N·m 1.00 to 1.15 kgf·m 7.24 to 8.31 lbf·ft

- (1) Breather Hose (3) Cylinder Head Cover
(2) Head Cover Screws

9Y1210982ENS0053US0

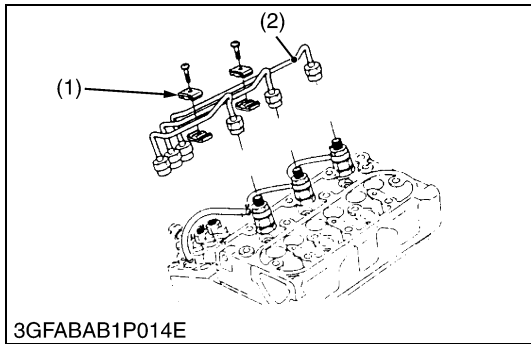

Injection Pipes

1. Loosen the screws on the pipe clamp (1).
2. Remove the injection pipes (2).

(When reassembling)

- Sent compressed air into the pipes to blow out dust. Then, reassemble the pipes in the reverse order.

Tightening torque	Injection pipe retaining nut	25 to 34 N·m 2.5 to 3.5 kgf·m 18 to 25 lbf·ft
-------------------	------------------------------	---

- (1) Pipe Clamp (2) Injection Pipe

9Y1210982ENS0054US0

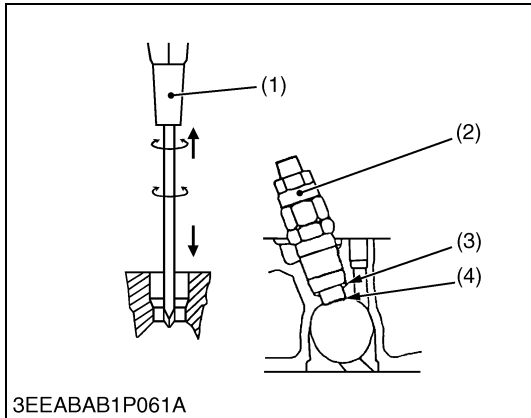

Nozzle Heat Seal Service Removal Procedure

■ IMPORTANT

- Use a plus (phillips head) screw driver that has a Dia. which is bigger than the heat seal hole (Approx. 6 mm (1/4 in.)).

1. Drive screw driver lightly into the heat seal hole.
2. Turn screw driver three or four times each way.
3. While turning the screw driver, slowly pull the heat seal out together with the injection nozzle gasket.

If the heat seal drops, repeat the above procedure. Heat seal and injection nozzle gasket must be changed when the injection nozzle is removed for cleaning or for service.

- (1) Plus Screw Driver (3) Injection Nozzle Packin
(2) Injection Nozzle (4) Heat Seal

9Y1210982ENS0055US0

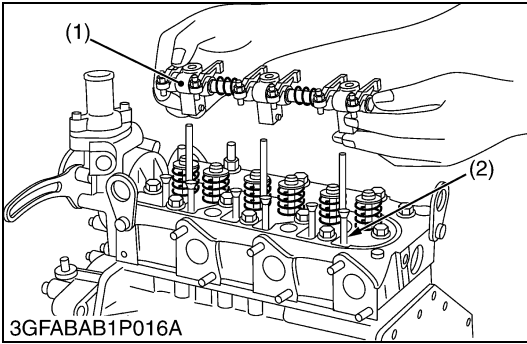

Rocker Arm and Push Rod

1. Remove the rocker arm bracket nut.
2. Remove the rocker arm assembly (1).
3. Remove the push rods (2).

(When reassembling)

- When putting the push rods (2) onto the tappets (3), check to see if their ends are properly engaged with the dimples.

IMPORTANT

- **After installing the rocker arm, be sure to adjust the valve clearance.**

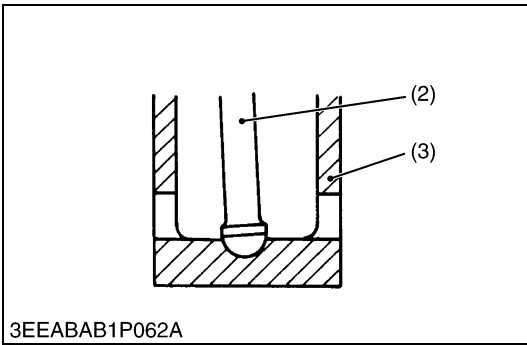

Tightening torque	Rocker arm bracket nut	22 to 26 N·m 2.2 to 2.7 kgf·m 16 to 19 lbf·ft
-------------------	------------------------	---

- (1) Rocker Arm Assembly (3) Tappet
(2) Push Rod

9Y1210982ENS0056US0

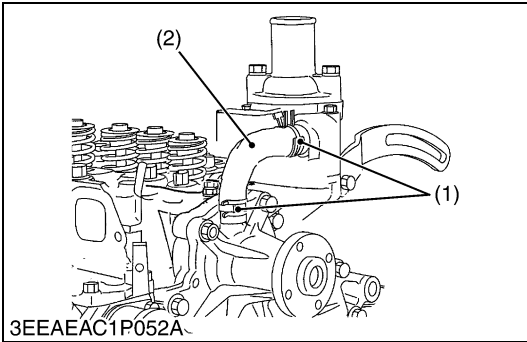

Cylinder Head

1. Loosen the hose clamps (1), and remove the water return hose (2).
2. Remove the cylinder head screw in the order of (n or r) to (a).
3. Lift up the cylinder head to remove.
4. Remove the cylinder head gasket.

(When reassembling)

- Replace the cylinder head gasket with new one.
- When mounting the gasket, set it to the pin pipe holes. Take care not to mount it reversely.
- The cylinder head should be free of scratches and dust.
- Install the cylinder head, using care not to damage the gasket.
- After applying engine oil to the thread of screws, tighten them in several steps and specified sequence (a) to (n or r).

NOTE

- **Do not use O-ring on the pin pipe.**
- **It is not necessary to retighten the cylinder head screw and to readjust valve clearance after engine warmed up.**

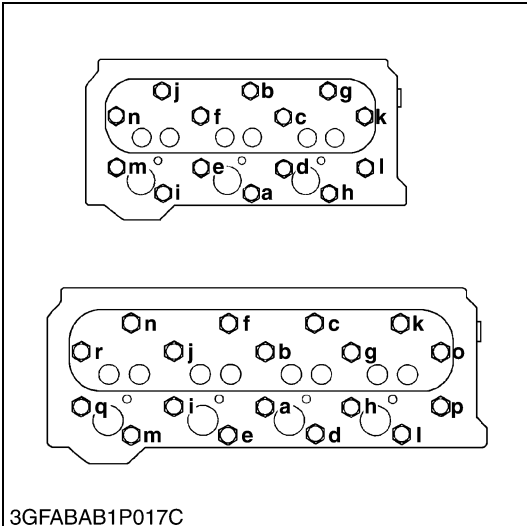

Tightening torque	Cylinder head screw	64 to 68 N·m 6.5 to 7.0 kgf·m 47 to 50 lbf·ft
-------------------	---------------------	---

- (1) Pipe Clamp (n or r) to (a): To Loosen
(2) Water Return Pipe (a) to (n or r): To Tighten
(3) Pin Pipe

9Y1210982ENS0057US0

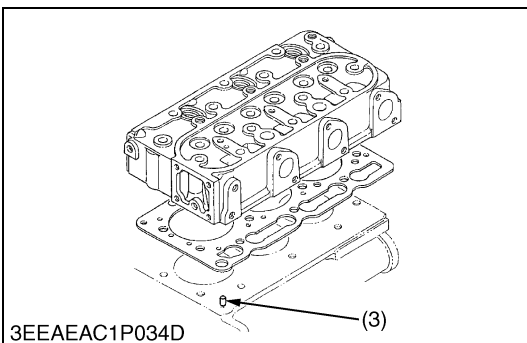

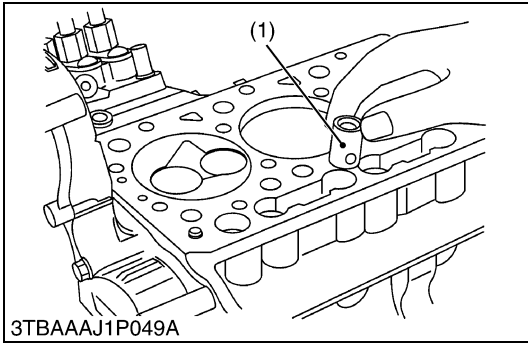

Tappets

1. Remove the tappets (1) from the crankcase.

(When reassembling)

- Visually check the contact between tappets and cams for proper rotation. If problem is found, replace tappets.
- Before installing the tappets, apply engine oil thinly around them.

■ **IMPORTANT**

- **Do not change the combination of tappet and tappet guide.**

(1) Tappet

9Y1210982ENS0058US0

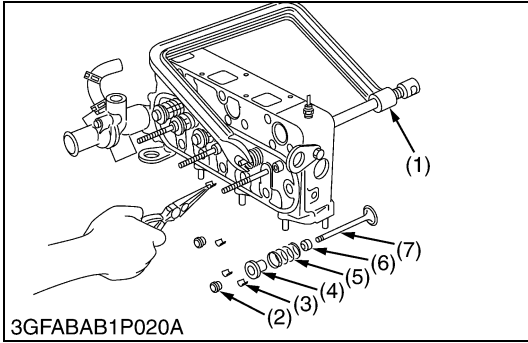

Valves

1. Remove the valve caps (2).
2. Remove the valve spring collet (3), pushing the valve spring retainer (4) by valve spring replacer (1).
3. Remove the valve spring retainer (4), valve spring (5) and valve stem seal (6).
4. Remove the valve (7).

(When reassembling)

- Wash the valve stem seal and valve guide hole, and apply engine oil sufficiently.
- After installing the valve spring collets, lightly tap the stem to assure proper fit with a plastic hammer.

■ **IMPORTANT**

- **Do not change the combination of valve and valve guide.**

(1) Valve Spring Replacer

(2) Valve Cap

(3) Valve Spring Collet

(4) Valve Spring Retainer

(5) Valve Spring

(6) Valve Stem Seal

(7) Valve

9Y1210982ENS0059US0

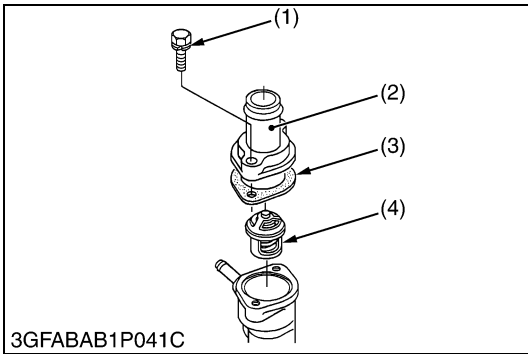

Thermostat Assembly

1. Remove the thermostat cover mounting screws (1), and remove the thermostat cover (2).
2. Remove the thermostat assembly (4).

(When reassembling)

- Apply a liquid gasket (Three Bond 1215 or equivalent) only at the thermostat cover side of the gasket (3).

(1) Thermostat Cover Mounting Screw

(2) Thermostat Cover

(3) Thermostat Cover Gasket

(4) Thermostat Assembly

9Y1210982ENS0060US0

(3) Gear Case

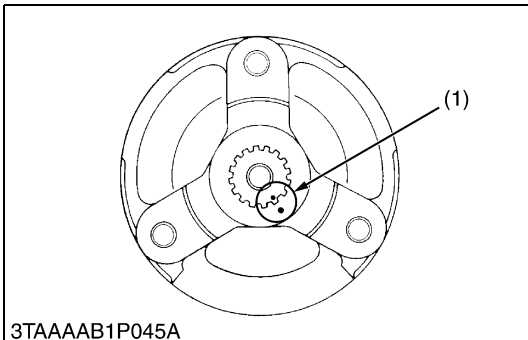

Fan Drive Pulley

1. Secure the flywheel to keep it from turning.
2. Remove the fan drive pulley screw.
3. Draw out the fan drive pulley with a puller.

(When reassembling)

- Install the pulley to the crankshaft, aligning the mark (1) on them.
- Apply engine oil to the fan drive pulley retaining screws. And tighten them.

Tightening torque	Fan drive pulley screw	236 to 245 N·m 24.0 to 25.0 kgf·m 174 to 180 lbf·ft
-------------------	------------------------	---

(1) Alignment Mark

9Y1210982ENS0061US0

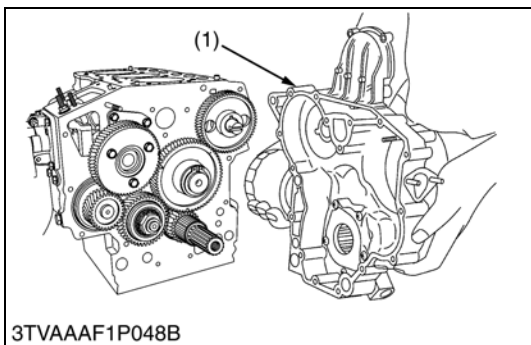

Gear Case

1. Remove the gear case (1).

(When reassembling)

- Grease thinly to the oil seal, and install it, ensuring the lip does not come off.

(1) Gear Case

- a: Bolt Length = 45 mm (1.8 in.)
- b: Bolt Length = 50 mm (2.0 in.)
- c: Bolt Length = 55 mm (2.2 in.)
- d: Bolt Length = 65 mm (2.6 in.)
- e: Bolt Length = 68 mm (2.7 in.)
- f: Bolt Length = 85 mm (3.3 in.)
- g: Nut

9Y1210982ENS0062US0

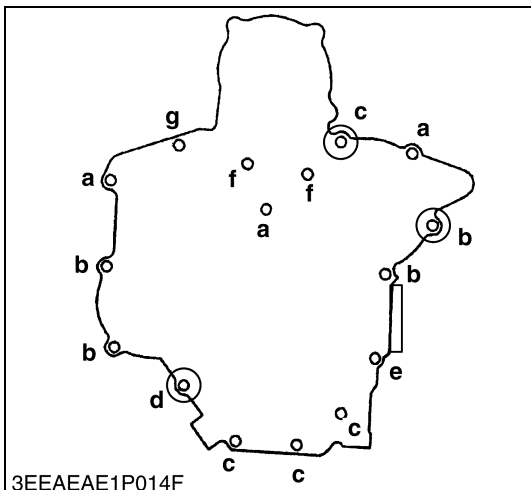

Engine Stop Solenoid and Speed Control Plate

1. Remove the engine stop solenoid.
2. Disconnect the governor spring (2) from the speed control plate (1).
3. Remove the speed control plate.

(When reassembling)

- Apply a liquid gasket (Three Bond 1215 or equivalent) to both sides of the solenoid cover gasket and control plate gasket.
- Be careful not to drop the governor springs into the crankcase.

(1) Speed Control Plate

(2) Governor Spring

9Y1210982ENS0063US0

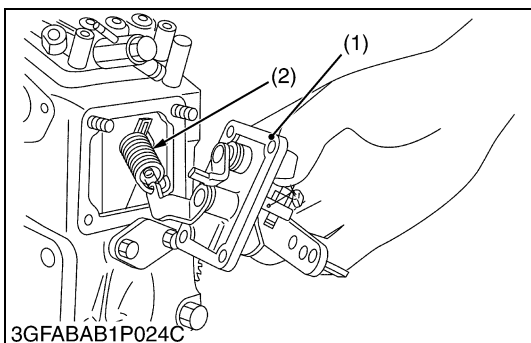

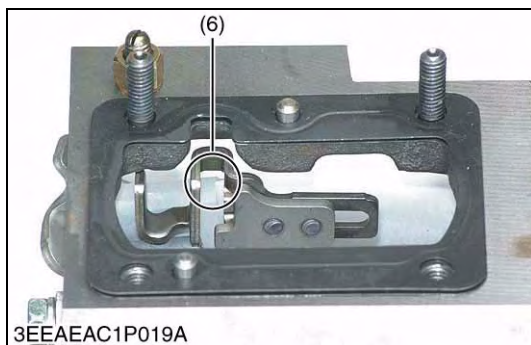
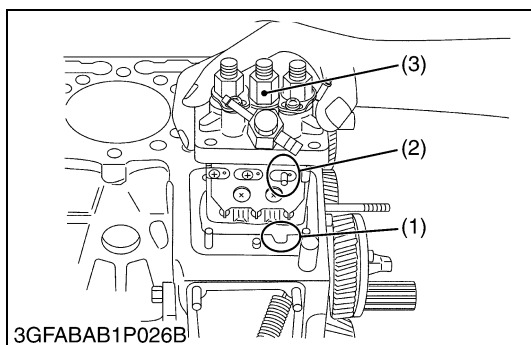

Injection Pump

1. Disconnect the starter spring (4) on the thrust lever side (5).
2. Align the control rack pin (2) with the notch (1) on the crankcase, and remove the injection pump (3).
3. Remove the injection pump shims.
4. In principle, the injection pump should not be disassembled.

(When reassembling)

- When installing the injection pump, insert the control rack pin (2) firmly into the groove (6) of the thrust lever of fork lever.

■ NOTE

- The sealant is applied to both sides of the soft metal gasket shim. The liquid gasket is not required for assembling.
- Addition or reduction of shim (0.05 mm, 0.002 in.) delays or advances the injection timing by approx. 0.0087 rad (0.5 °).
- In disassembling and replacing, be sure to use the same number or new gasket shims with the same thickness.

- (1) Notch
 (2) Control Rack Pin
 (3) Injection Pump

- (4) Start Spring
 (5) Thrust Lever
 (6) Groove

9Y1210982ENS0064US0

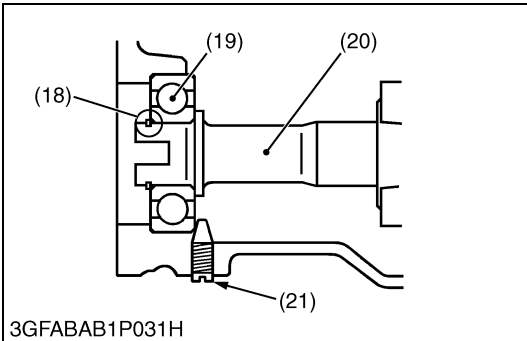
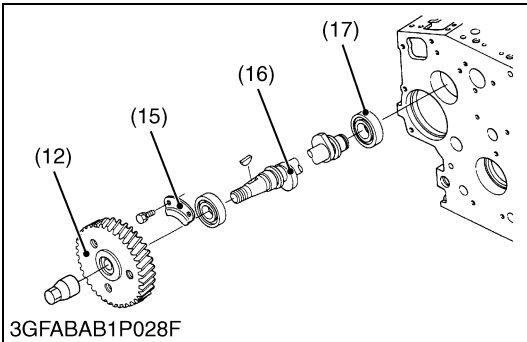
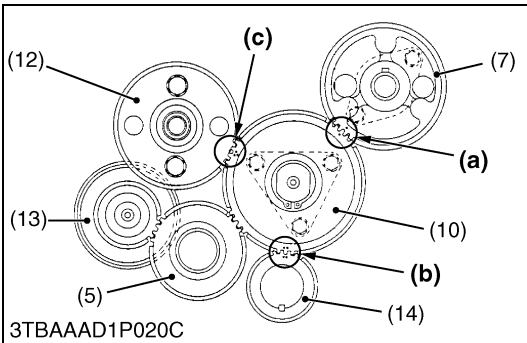
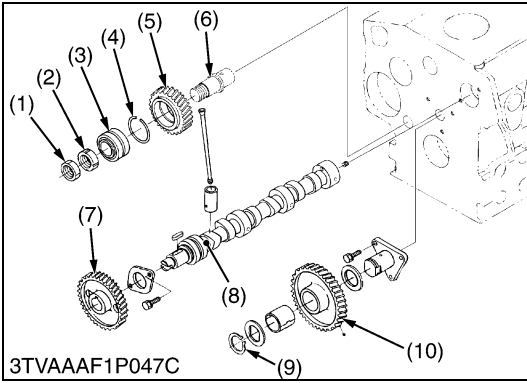

Cam Gear, Idle Gear 1, 2 and Governor Gear

1. Remove the external snap ring (9), and then remove the idle gear 1 (10).
2. Remove the lock nut (1), and then remove the bearing nut (2) with a bearing nut finger socket (11).
3. Remove the idle gear 2 (5) with taper roller bearing.
4. Remove the fuel camshaft stopper (15).
5. Draw out the fuel cam gear (12) with fuel camshaft (16).
6. Remove the camshaft stopper bolt.
7. Remove the cam gear (7) with camshaft.
8. Remove the external snap ring (18) from the governor shaft (20).
9. Remove the governor gear (13) with governor shaft (20).

NOTE

- **Three-lever type fork lever**
To remove the governor shaft, follow the procedures in 8, 9 above and never remove fork lever and the max torque limiter.

(When reassembling)

- Apply engine oil thinly to the fuel camshaft before installation.
- Make sure to assemble the external snap ring of the governor shaft.
- Check the governor shaft for smooth rotation.
- Tighten the idle gear 2 bearing nut and the idle gear lock nut to the specified tightening torque.

IMPORTANT

- When replacing the ball bearing of governor shaft, securely fit the ball bearing (18) to the crankcase, apply an adhesive (Three Bond 1324B or equivalent) to the set screw (20), and fasten the screw until its tapered part contacts the circumferential end of the ball bearing.
- When installing the idle gear 1, be sure to align the alignment marks on each gear.

Tightening torque	Idle gear 2 lock nut	25 to 29 N·m 2.5 to 3.0 kgf·m 18 to 21 lbf·ft
	Idle gear 2 bearing nut	35 to 39 N·m 3.5 to 4.0 kgf·m 26 to 28 lbf·ft

- | | |
|--|--|
| <ul style="list-style-type: none"> (1) Lock Nut (2) Bearing Nut (3) Taper Roller Bearing (4) Cir-Clip (5) Idle Gear 2 (6) Idle Gear Shaft (7) Cam Gear (8) Camshaft (9) External Snap Ring (10) Idle Gear 1 (11) Bearing Nut Finger Socket (12) Fuel Cam Gear (13) Governor Gear (14) Crank Gear | <ul style="list-style-type: none"> (15) Stopper (16) Fuel Camshaft (17) Ball Bearing (18) External Snap Ring (19) Ball Bearing (20) Governor Shaft (21) Set Screw <p>(a) Alignment Mark: Idle Gear 1 and Cam Gear
 (b) Alignment Mark: Idle Gear 1 and Crank Gear
 (c) Alignment Mark: Idle Gear 1 and Fuel Cam Gear</p> |
|--|--|

9Y1210982ENS0065US0

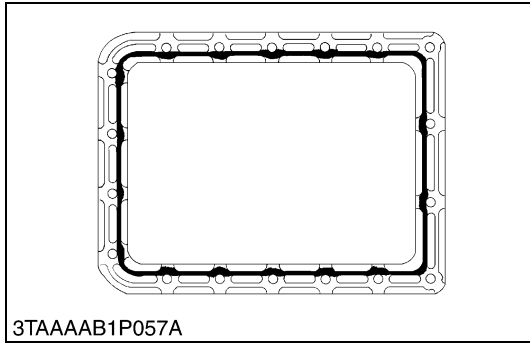
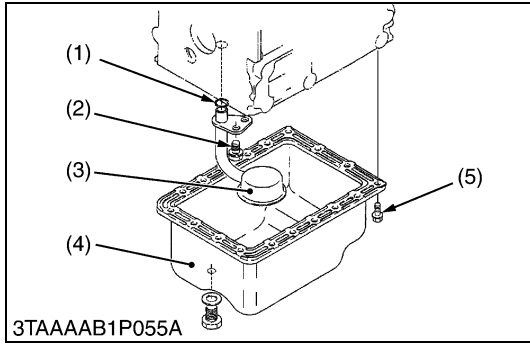

Oil Pan and Oil Strainer

1. Remove the oil pan mounting screws (5).
2. Remove the oil pan (4).
3. Remove the oil strainer (3).

(When reassembling)

- After cleaning the oil strainer, check to see that the filter mesh is clean, and install it.
- Visually check the O-ring (1), apply engine oil, and install it.
- Securely fit the O-ring to the oil strain.
- To avoid uneven tightening, tighten oil pan mounting screws in diagonal order from the center.

■ IMPORTANT

- **Scrape off the old adhesive completely. Wipe the sealing surface clean using waste cloth soaked with gasoline. Now apply new adhesive 3 to 5 mm (0.12 to 0.20 in.) thick all over the contact surface. Apply the adhesive also on the center of the flange as well as on the inner wall of each screw hole.**
- **Cut the nozzle of the "liquid gasket" container at its second notch. Apply "liquid gasket" about 5 mm (0.2 in.) thick. Within 20 minutes after the application of fluid sealant, reassemble the components. Wait then for about 30 minutes, and pour oil in the crankcase.**

- | | |
|------------------|-----------------------------|
| (1) O-ring | (4) Oil Pan |
| (2) Screw | (5) Oil Pan Mounting Screws |
| (3) Oil Strainer | |

9Y1210982ENS0066US0

(4) Piston and Connecting Rod

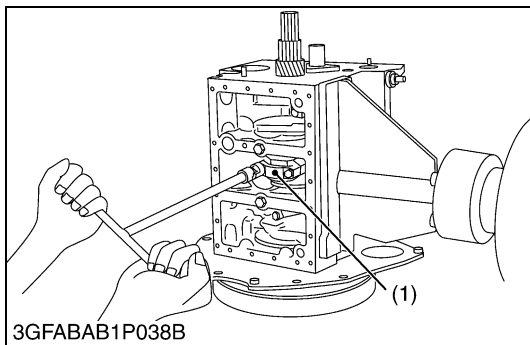

Connecting Rod

1. Remove the connecting rod cap.

(When reassembling)

- Align the marks **(a)** with each other. (Face the marks toward the injection pump.)
- Apply engine oil to the connecting rod screws (1) and lightly screw it in by hand, then tighten it to the specified torque. If the connecting rod screw won't be screwed in smoothly, clean the threads. If the connecting rod screw (1) is still hard to screw in, replace it.

Tightening torque	Connecting rod screw	42 to 46 N·m 4.2 to 4.7 kgf·m 31 to 33 lbf·ft
-------------------	----------------------	---

- | | |
|--------------------------|----------|
| (1) Connecting Rod Screw | (a) Mark |
|--------------------------|----------|

9Y1210982ENS0067US0

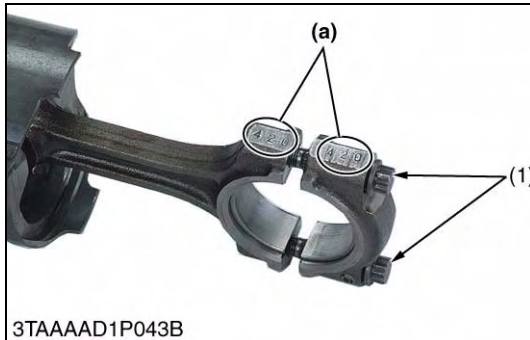

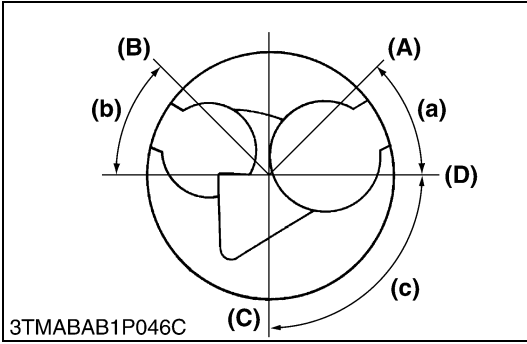
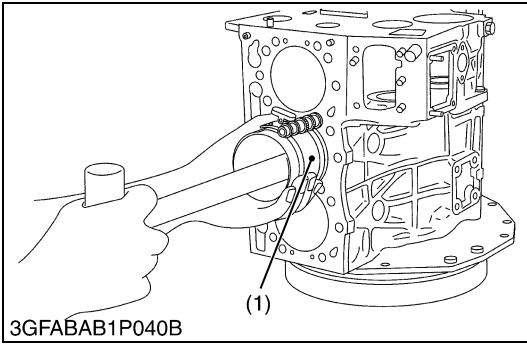
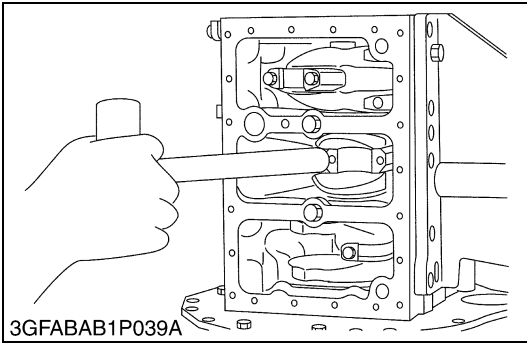

Piston

1. Turn the flywheel and bring the piston to top dead center.
2. Draw out the piston upward by lightly tapping it from the bottom of the crankcase with the grip of a hammer.
3. Draw out the other piston in the same method as above.

(When reassembling)

- Before inserting the piston into the cylinder, apply enough engine oil to the piston.
- When inserting the piston into the cylinder, face the mark on the connecting rod to the injection pump.

■ IMPORTANT

- **Do not change the combination of cylinder and piston. Make sure of the position of each piston by marking. For example, mark "1" on the No.1 piston.**
- **When installing the piston into the cylinder, place the gaps of all the piston rings as shown in the figure.**
- **Carefully insert the piston using a piston ring compressor (1). Otherwise, their chrome-plated section may be scratched, causing trouble inside the cylinder.**

- | | |
|----------------------------|---------------------|
| (1) Piston Ring Compressor | (a) 0.79 rad (45 °) |
| | (b) 0.79 rad (45 °) |
| (A) Top Ring Gap | (c) 1.6 rad (90 °) |
| (B) Second Ring Gap | |
| (C) Oil Ring Gap | |
| (D) Piston Pin Hole | |

9Y1210982ENS0068US0

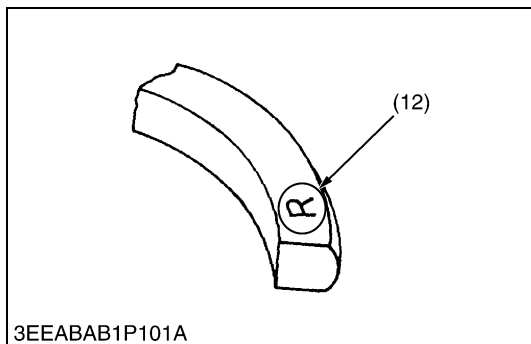
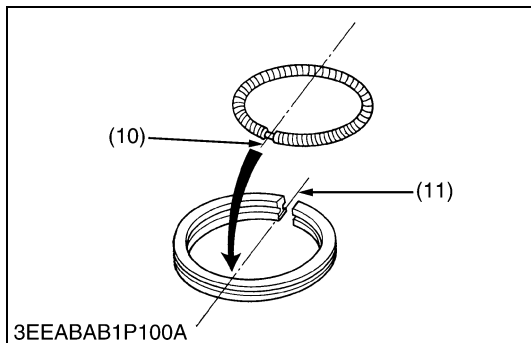
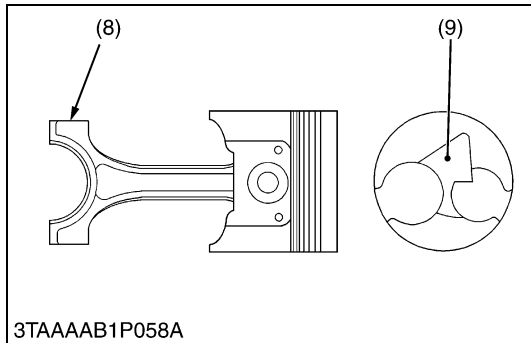
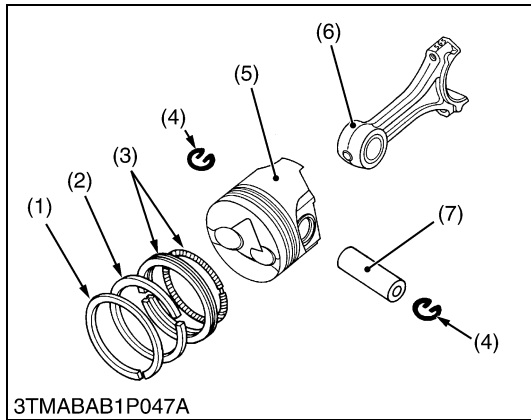

Piston Ring and Connecting Rod

1. Remove the piston rings using a piston ring tool.
2. Remove the piston pin (7), and separate the connecting rod (6) from the piston (5).

(When reassembling)

- Install the rings so that the manufacturer's mark (12) near the gap faces the top of the piston.
- When installing the oil ring onto the piston, place the expander joint (10) on the opposite side of the oil ring gap (11).
- Apply engine oil to the piston pin.
- When installing the connecting rod to the piston, immerse the piston in 80 °C (176 °F) oil for 10 to 15 minutes and insert the piston pin to the piston.
- When installing the connecting rod to the piston, align the mark (8) on the connecting rod to the fan-shaped concave (9).

■ **NOTE**

- **Mark the same number on the connecting rod and the piston so as not to change the combination.**

- | | |
|--------------------------|--------------------------|
| (1) Top Ring | (7) Piston Pin |
| (2) Second Ring | (8) Mark |
| (3) Oil Ring | (9) Fan-Shaped Concave |
| (4) Piston Pin Snap Ring | (10) Expander Joint |
| (5) Piston | (11) Oil Ring Gap |
| (6) Connecting Rod | (12) Manufacturer's Mark |

9Y1210982ENS0069US0

(5) Crankshaft

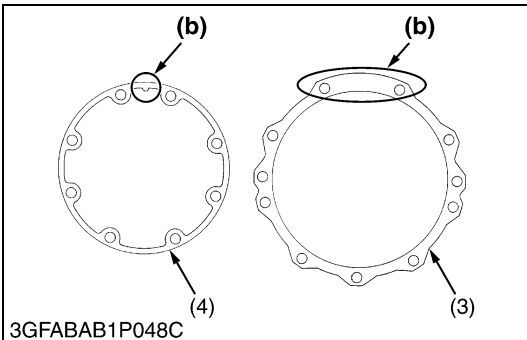
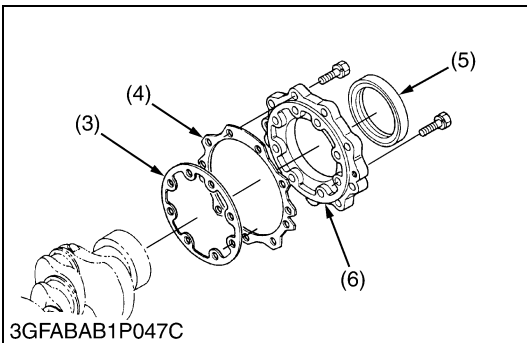
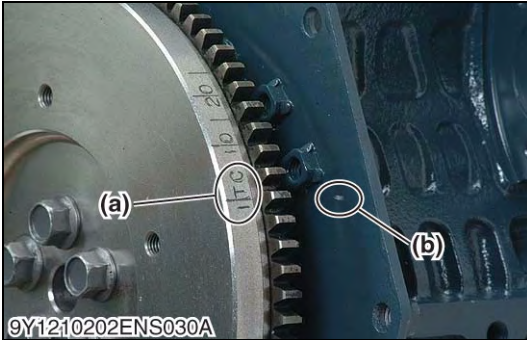
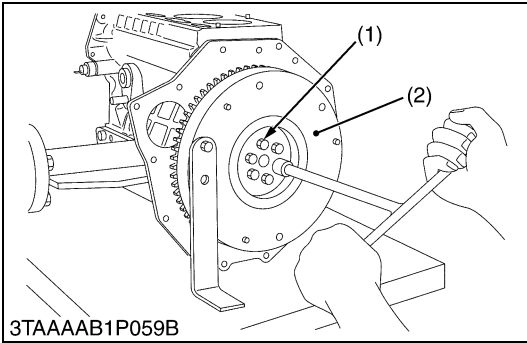

Flywheel

1. Secure the flywheel to keep it from turning, using a flywheel stopper.
2. Remove all flywheel screws (1) and then remove the flywheel (2).

(When reassembling)

- Align the "1TC" mark (a) on the the outer surface of the flywheel horizontally with the alignment mark (b) on the rear end plate. Now fit the flywheel in position.
- Apply engine oil to the threads and the undercut surface of the flywheel screw and fit the screw.

Tightening torque	Flywheel screw	53.9 to 58.8 N·m 5.5 to 6.0 kgf·m 39.8 to 43.4 lbf·ft
-------------------	----------------	---

- (1) Flywheel Screw
(2) Flywheel

- (a) 1TC Mark
(b) Alignment Mark

9Y1210982ENS0070US0

Bearing Case Cover

1. Remove the bearing case cover mounting screws.
2. Remove the bearing case cover (6).

■ IMPORTANT

- The length of inside screws (1) and outside screws (2) are difference. Do not take a mistake using inside screws and outside screws.

(When reassembling)

- Fit the bearing case gasket (3) and the bearing case cover gasket (4) with correct directions.
- Install the bearing case cover (6) to position the casting mark "UP" (a) on it upward.
- Apply engine oil to the oil seal (5) lip and take care that it is not rolled when installing.
- Tighten the bearing case cover mounting screws with even force on the diagonal line.

Tightening torque	Bearing case cover screw	9.81 to 11.2 N·m 1.00 to 1.15 kgf·m 7.24 to 8.31 lbf·ft
-------------------	--------------------------	---

- (1) Bearing Case Cover Mounting Screw (Inside)
(2) Bearing Case Cover Mounting Screw (Outside)
(3) Bearing Case Gasket
(4) Bearing Case Cover Gasket

- (5) Oil Seal
(6) Bearing Case Cover

- (a) Top Mark "UP"
(b) Upside

9Y1210982ENS0071US0

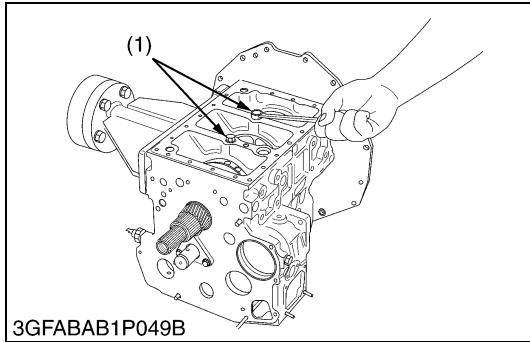

Crankshaft Assembly (Except D1305)

1. Remove the main bearing case screw 2 (1).
2. Pull out the crankshaft assembly.

■ **IMPORTANT**

- Take care to protect crankshaft bearing 1 from scratches, caused by the crank gear, etc.. (Wrap the gear in vinyl tape, etc.).

(When reassembling)

- Clean the oil passage of the crankshaft with compressed air.
- Apply oil to the main bearing case screw 2 (1).
- Install the crankshaft assembly, aligning the screw hole of main bearing case with the screw hole of crankcase.
- Clean the oil passage of the crankshaft with compressed air.

Tightening torque	Main bearing case screw 2	49 to 53 N·m 5.0 to 5.5 kgf·m 37 to 39 lbf·ft
-------------------	---------------------------	---

(1) Main Bearing Case Screw 2

9Y1210982ENS0072US0

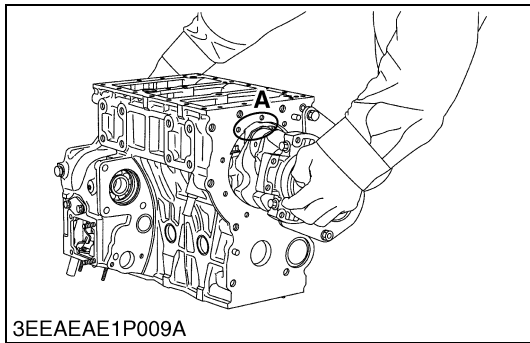

Crankshaft Assembly [D1305-E4]

1. Remove the main bearing case screw 2.
2. Turn the crankshaft to set the crankpin of the third cylinder to the **A**. Then draw out the crankshaft until the crankpin of the second cylinder comes to the center of the third cylinder.
3. Turn the crankshaft by 2.09 rad (120 °) counterclockwise to set the crankpin of the second cylinder to the **A**. Draw out the crankshaft until the crankpin of the first cylinder comes to the center of third cylinder.
4. Repeat the above steps to draw out all the crankshaft.

(When reassembling)

- Clean the oil passage of the crankshaft with compressed air.
- Install the crankshaft assembly, aligning the screw hole of main bearing case screw 2 with the screw hole of crankcase.
- When tightening the main bearing case 2, apply oil to the main bearing case screw 2 and screw by hand before tightening the specific torque. If not smooth to screw by hand, align the screw holes between the crankcase and the main bearing case.

Tightening torque	Main bearing case screw 2	49 to 53 N·m 5.0 to 5.5 kgf·m 37 to 39 lbf·ft
-------------------	---------------------------	---

A: Cut place for removing and installing the crankshaft

9Y1210982ENS0073US0

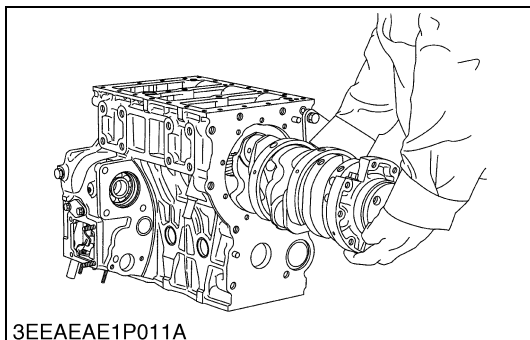
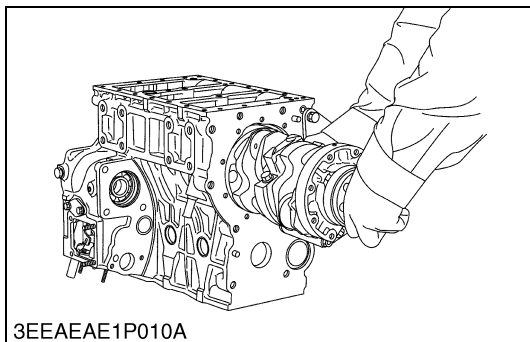

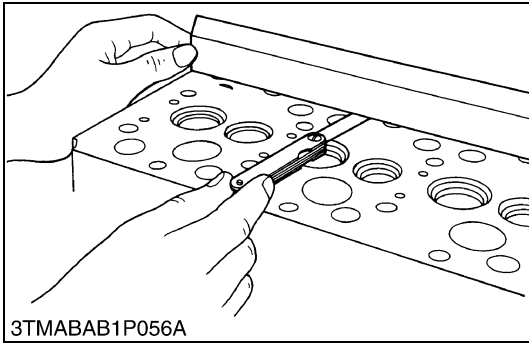

Cylinder Head Surface Flatness

1. Clean the cylinder head surface.
2. Place a straightedge on the cylinder head's four sides and two diagonal as shown in the figure.
3. Measure the clearance with a thickness gauge.
4. If the measurement exceeds the allowable limit, correct it with a surface grinder.

IMPORTANT

- Do not place the straightedge on the combustion chamber.
- Be sure to check the valve recessing after correcting.

Cylinder head surface flatness	Allowable limit	0.05 mm 0.002 in.
--------------------------------	-----------------	----------------------

9Y1210982ENS0076US0

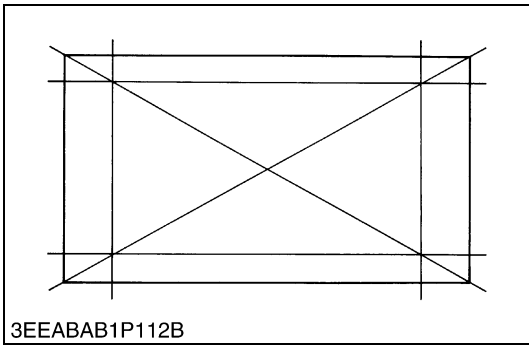

Cylinder Head Flaw

1. Prepare an air spray red check.
2. Clean the surface of the cylinder head with detergent (2).
3. Spray the cylinder head surface with the red permeative liquid (1). Leave it five to ten minutes after spraying.
4. Wash away the red permeative liquid on the cylinder head surface with the detergent (2).
5. Spray the cylinder head surface with white developer (3).
6. If flawed, it can be identified as red marks.

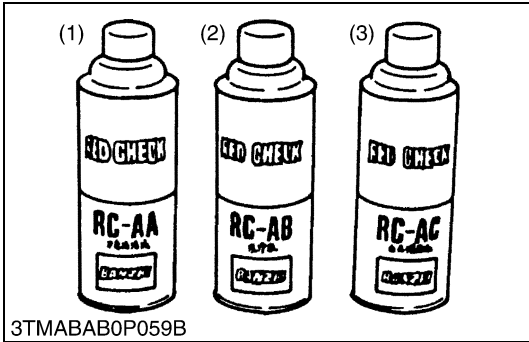

- (1) Red Permeative Liquid (3) White Developer
(2) Detergent

9Y1210982ENS0077US0

Valve Recessing

1. Clean the cylinder head surface, the valve face and the valve seat.
2. Insert the valve into the valve guide.
3. Measure the valve recessing with a depth gauge.
4. If the measurement exceeds the allowable limit, replace the valve.
5. If it still exceeds the allowable limit after replacing the valve, replace the cylinder head.

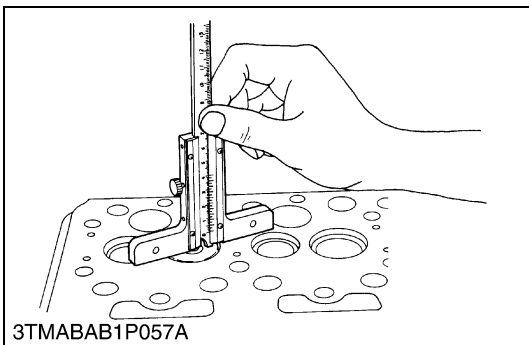

Valve recessing	Factory specification	0.050 (protrusion) to 0.25 (recessing) mm 0.0020 (protrusion) to 0.0098 (recessing) in.
	Allowable limit	0.40 (recessing) mm 0.016 (recessing) in.

- (1) Cylinder Head Surface (A) Recessing
(B) Protrusion

9Y1210982ENS0078US0

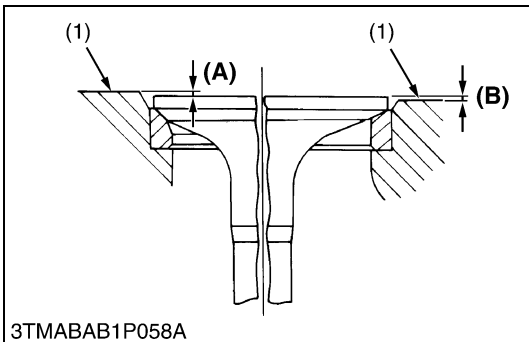

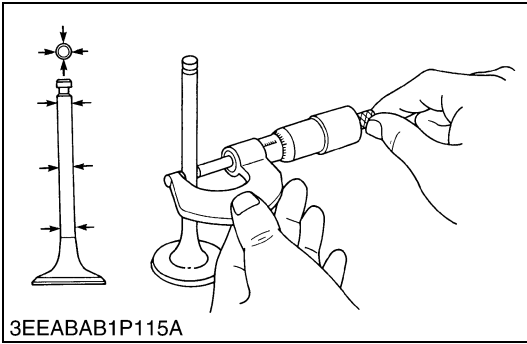

3EEABAB1P115A

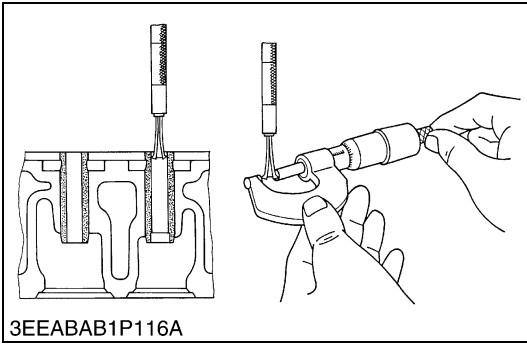

3EEABAB1P116A

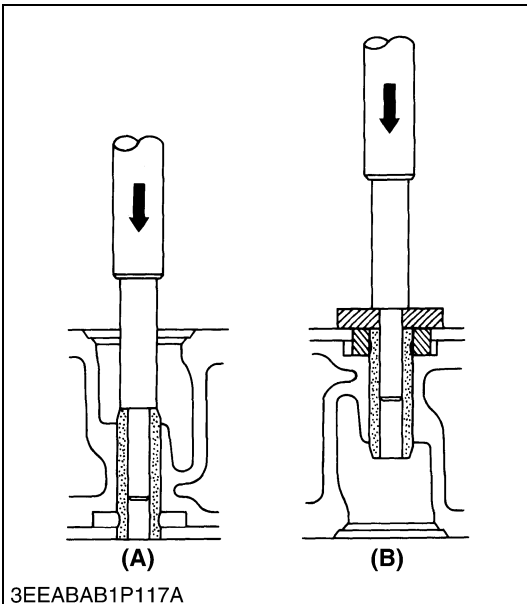

3EEABAB1P117A

Clearance between Valve Stem and Valve Guide

1. Remove carbon from the valve guide section.
2. Measure the valve stem O.D. with an outside micrometer.
3. Measure the valve guide I.D. with a small hole gauge, and calculate the clearance.
4. If the clearance exceeds the allowable limit, replace the valves. If it still exceeds the allowable limit, replace the valve guide.

Clearance between valve stem and valve guide	Factory specification	0.035 to 0.065 mm 0.0014 to 0.0025 in.
	Allowable limit	0.10 mm 0.0039 in.

Valve stem O.D.	Factory specification	6.960 to 6.975 mm 0.2741 to 0.2746 in.
Valve guide I.D.	Factory specification	7.010 to 7.025 mm 0.2760 to 0.2765 in.

9Y1210982ENS0079US0

Replacing Valve Guide

(When removing)

1. Press out the used valve guide using a valve guide replacing tool. (See page "SPECIAL TOOLS".)

(When installing)

1. Clean a new valve guide and valve guide bore, and apply engine oil to them.
2. Press in a new valve guide using a valve guide replacing tool.
3. Ream precisely the I.D. of the valve guide to the specified dimension.

Valve guide I.D. (Intake and exhaust)	Factory specification	7.010 to 7.025 mm 0.2760 to 0.2765 in.
---------------------------------------	-----------------------	---

■ IMPORTANT

- Do not hit the valve guide with a hammer during replacement.

(A) When Removing

(B) When Installing

9Y1210982ENS0080US0

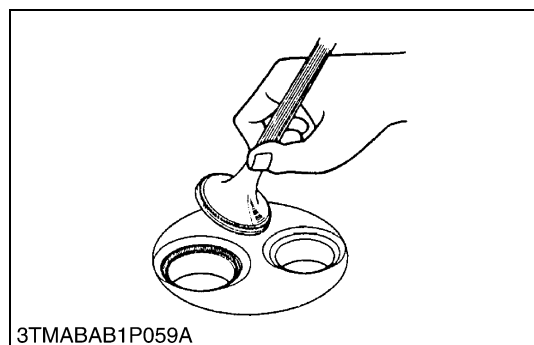

Valve Seating

1. Coat the valve face lightly with prussian blue and put the valve on its seat to check the contact.
2. If the valve does not seat all the way around the valve seat or the valve contact is less than 70 %, correct the valve seating as follows.
3. If the valve contact does not comply with the reference value, replace the valve or correct the contact of valve seating.

Valve seat width	Factory specification	2.12 mm 0.0835 in.
------------------	-----------------------	-----------------------

- (1) Correct
(2) Incorrect

(3) Incorrect

9Y1210982ENS0081US0

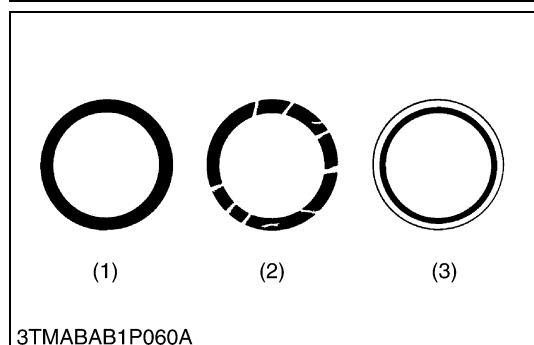

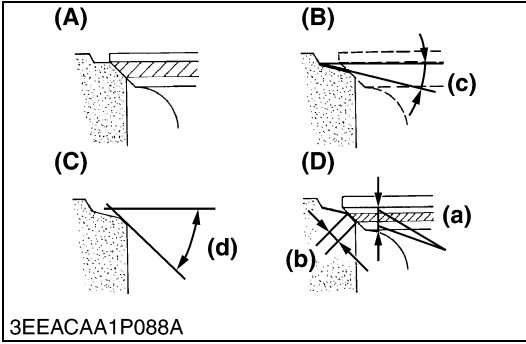
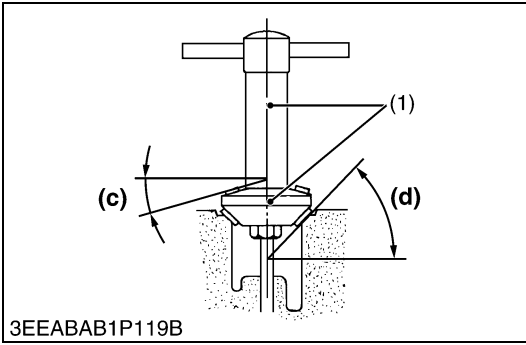
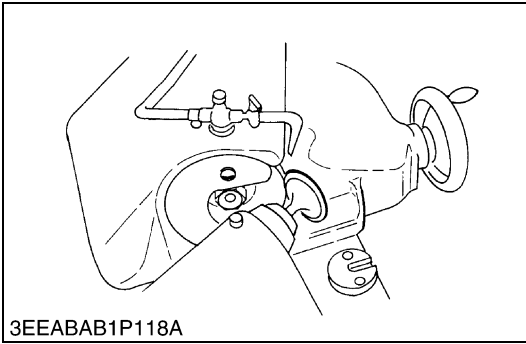

Correcting Valve and Valve Seat

■ **NOTE**

- Before correcting the valve and the seat, check the valve stem and the I.D. of valve guide section, and repair them if necessary.
- After correcting the valve seat, be sure to check the valve recessing.

1) Correcting Valve

1. Correct the valve with a valve refacer.

Valve face angle	Factory specification	IN.	1.047 rad 60 °
		EX.	0.785 rad 45 °

2) Correcting Valve Seat

1. Slightly correct the seat surface with a 0.785 rad (45 °) / 1.047 rad (60 °) valve seat cutter.
2. Fitting the valve, check the contact position of the valve face and seat surface with prussian blue. (Visual check) [If the valve has been used for a long period, the seat tends to come in contact with the upper side of the valve face.]
3. Grind the upper surface of the seat with a 0.523 rad (30 °) valve seat cutter until the valve seat touches to the center of the valve face (so that (a) equals (b) as shown in the figure).
4. Grind the seat with a 0.262 rad (15 °) valve seat cutter again, and visually recheck the contact between the valve and the seat.
5. Repeat steps 3 and 4 until the correct contact is achieved.
6. Continue lapping until the seated rate becomes more than 70 % of the total contact area.

Valve seat angle	Factory specification	IN.	1.047 rad 60 °
		EX.	0.785 rad 45 °

- | | |
|--------------------------|--------------------------|
| (1) Valve Seat Width | (a) Identical Dimensions |
| (A) Check Contact | (b) Valve Seat Width |
| (B) Correct Seat Width | (c) 0.262 rad (15 °) |
| (C) Correct Seat Surface | (d) 0.785 rad (45 °) |
| (D) Check Contact | |

9Y1210982ENS0082US0

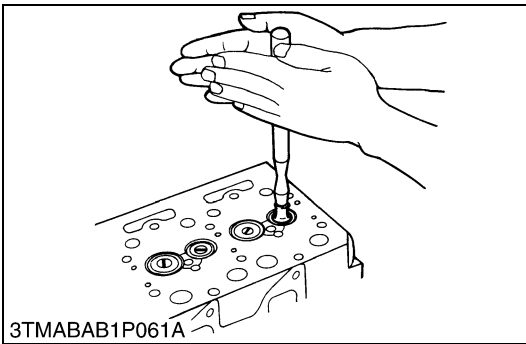

Valve Lapping

1. Apply compound evenly to the valve lapping surface.
2. Insert the valve into the valve guide. Lap the valve onto its seat with a valve flapper or screwdriver.
3. After lapping the valve, wash the compound away and apply oil, then repeat valve lapping with oil.
4. Apply prussian blue to the contact surface to check the seated rate. If it is less than 70 %, repeat valve lapping again.

■ **IMPORTANT**

- When valve lapping is performed, be sure to check the valve recessing and adjust the valve clearance after assembling the valve.

9Y1210982ENS0083US0

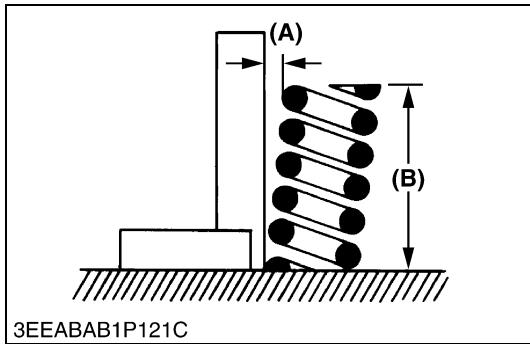

Free Length and Tilt of Valve Spring

1. Measure the free length **(B)** of valve spring with vernier calipers. If the measurement is less than the allowable limit, replace it.
2. Put the valve spring on a surface plate, place a square on the side of the valve spring.
3. Check to see if the entire side is in contact with the square. Rotate the valve spring and measure the maximum tilt **(A)**. If the measurement exceeds the allowable limit, replace it.
4. Check the entire surface of the valve spring for scratches. If there is any problem, replace it.

Tilt (A)	Allowable limit	1.0 mm 0.039 in.
-----------------	-----------------	---------------------

Free length (B)	Factory specification	37.0 to 37.5 mm 1.46 to 1.47 in.
	Allowable limit	36.5 mm 1.44 in.

(A) Tilt

(B) Free Length

9Y1210982ENS0084US0

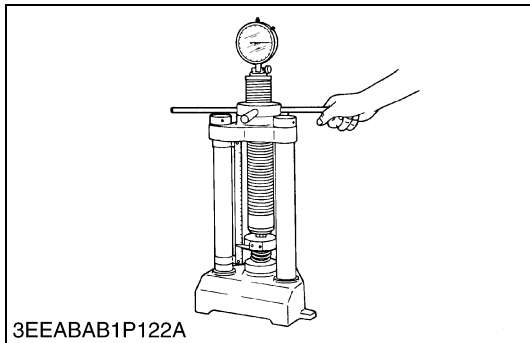

Valve Spring Setting Load

1. Place the valve spring on a tester and compress it to the same length it is actually compressed in the engine.
2. Read the compression load on the gauge.
3. If the measurement is less than the allowable limit, replace it.

Setting load / Setting length	Factory specification	117.4 N / 31.0 mm 11.97 kgf / 31.0 mm 26.39 lbf / 1.22 in.
	Allowable limit	100.0 N / 31.0 mm 10.20 kgf / 31.0 mm 22.48 lbf / 1.22 in.

9Y1210982ENS0085US0



Oil Clearance between Rocker Arm and Rocker Arm Shaft

1. Measure the rocker arm shaft O.D. with an outside micrometer.
2. Measure the rocker arm I.D. with an inside micrometer, and then calculate the oil clearance.
3. If the oil clearance exceeds the allowable limit, replace the rocker arm and measure the oil clearance again. If it still exceeds the allowable limit, replace also the rocker arm shaft.

Oil clearance between rocker arm and rocker arm shaft	Factory specification	0.016 to 0.045 mm 0.00063 to 0.0017 in.
	Allowable limit	0.10 mm 0.0039 in.

Rocker arm shaft O.D.	Factory specification	11.973 to 11.984 mm 0.47138 to 0.47181 in.
Rocker arm I.D.	Factory specification	12.000 to 12.018 mm 0.47244 to 0.47314 in.

9Y1210982ENS0086US0

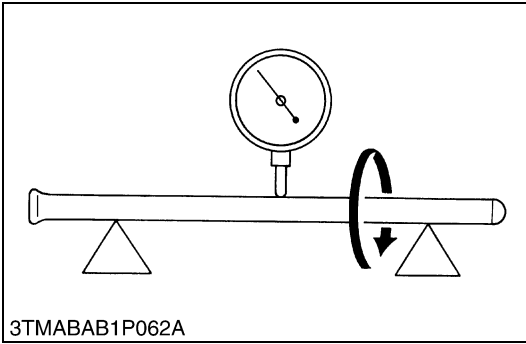

3TMABAB1P062A

Push Rod Alignment

1. Place the push rod on V blocks.
2. Measure the push rod alignment.
3. If the measurement exceeds the allowable limit, replace the push rod.

Push rod alignment	Allowable limit	0.25 mm 0.0098 in.
--------------------	-----------------	-----------------------

9Y1210982ENS0087US0



3TAAAD1P061A

Oil Clearance between Tappet and Tappet Guide Bore

1. Measure the tappet O.D. with an outside micrometer.
2. Measure the I.D. of the tappet guide bore with a cylinder gauge, and calculate the oil clearance.
3. If the oil clearance exceeds the allowable limit or the tappet is damaged, replace the tappet.

Oil Clearance between tappet and tappet guide bore	Factory specification	0.020 to 0.062 mm 0.00079 to 0.0024 in.
	Allowable limit	0.07 mm 0.003 in.

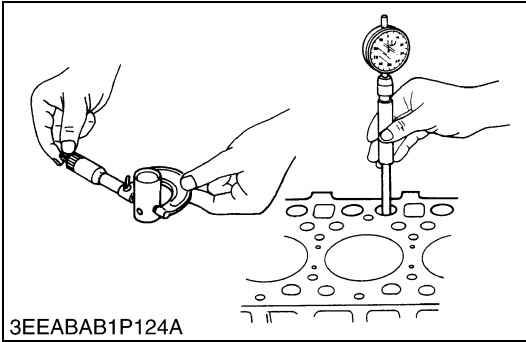

3EEABAB1P124A

Tappet O.D.	Factory specification	19.959 to 19.980 mm 0.78579 to 0.78661 in.
Tappet guide bore I.D.	Factory specification	20.000 to 20.021 mm 0.78740 to 0.78822 in.

9Y1210982ENS0088US0

(2) Idle Gear and Camshaft

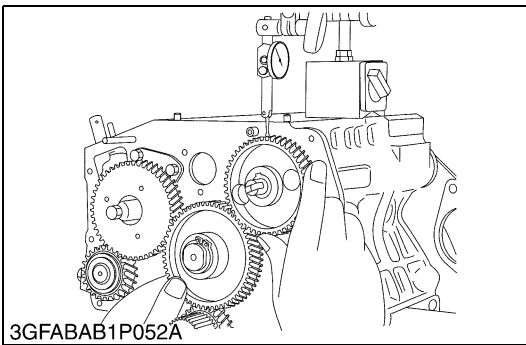

3GFABAB1P052A

Timing Gear Backlash

1. Set a dial indicator (lever type) with its tip on the gear tooth.
2. Move the gear to measure the backlash, holding its mating gear.
3. If the backlash exceeds the allowable limit, check the oil clearance of the shafts and the gear.
4. If the oil clearance is proper, replace the gear.

Backlash between idle gear 1 and crank gear	Factory specification	0.0320 to 0.115 mm 0.00126 to 0.00452 in.
	Allowable limit	0.15 mm 0.0059 in.

Backlash between idle gear 1 and cam gear	Factory specification	0.0360 to 0.114 mm 0.00142 to 0.00448 in.
	Allowable limit	0.15 mm 0.0059 in.

Backlash between idle gear 1 and injection pump gear	Factory specification	0.0340 to 0.116 mm 0.00134 to 0.00456 in.
	Allowable limit	0.15 mm 0.0059 in.

Idle gear 1 and idle gear 2	Factory specification	0.0330 to 0.117 mm 0.00130 to 0.00460 in.
	Allowable limit	0.15 mm 0.0059 in.

9Y1210982ENS0089US0

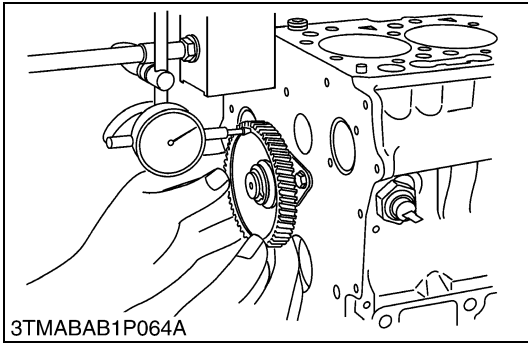

Idle Gear 1 and 2 Side Clearance

1. Set a dial indicator with its tip on the idle gear.
2. Measure the side clearance by moving the idle gear to the front and rear.
3. If the measurement exceeds the allowable limit, replace the idle gear collar.

Idle gear 1 and 2 side clearance	Factory specification	0.20 to 0.51 mm 0.0079 to 0.020 in.
	Allowable limit	0.8 mm 0.031 in.

9Y1210982ENS0090US0

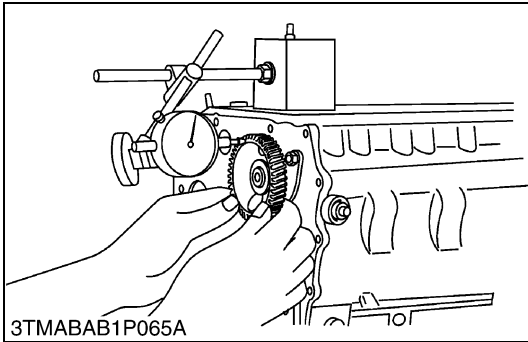

Camshaft Side Clearance

1. Set a dial indicator with its tip on the camshaft.
2. Measure the side clearance by moving the cam gear to the front to rear.
3. If the measurement exceeds the allowable limit, replace the camshaft stopper.

Camshaft side clearance	Factory specification	0.070 to 0.22 mm 0.0028 to 0.0086 in.
	Allowable limit	0.30 mm 0.012 in.

9Y1210982ENS0091US0

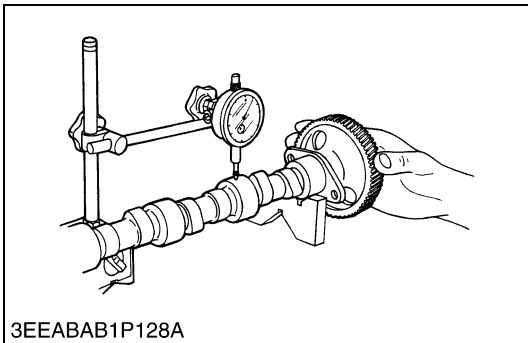

Camshaft Alignment

1. Support the camshaft with V blocks on the surface plate at both end journals.
2. Set a dial indicator with its tip on the intermediate journal.
3. Measure the camshaft alignment.
4. If the measurement exceeds the allowable limit, replace the camshaft.

Camshaft alignment	Allowable limit	0.01 mm 0.0004 in.
--------------------	-----------------	-----------------------

9Y1210982ENS0092US0

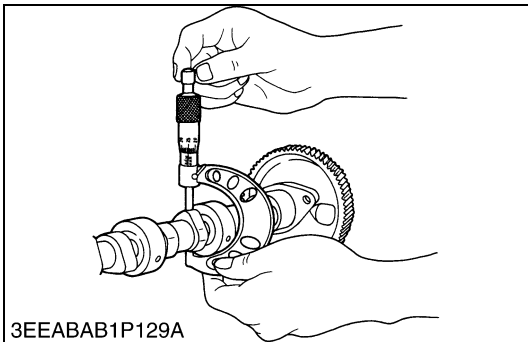

Cam Height

1. Measure the height of the cam at its highest point with an outside micrometer.
2. If the measurement is less than the allowable limit, replace the camshaft.

Cam height of intake	Factory specification	28.80 mm 1.134 in.
	Allowable limit	28.75 mm 1.132 in.

Cam height of exhaust	Factory specification	29.00 mm 1.142 in.
	Allowable limit	28.95 mm 1.140 in.

9Y1210982ENS0093US0

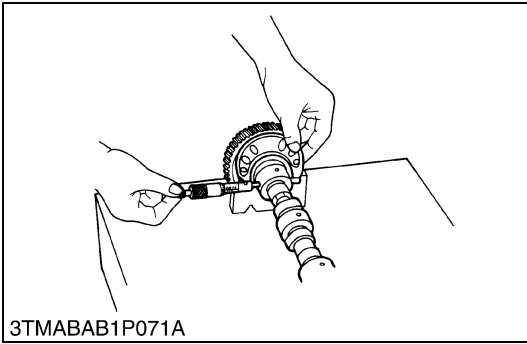

Oil Clearance of Camshaft Journal

1. Measure the camshaft journal O.D. with an outside micrometer.
2. Measure the cylinder block bore I.D. for camshaft with a cylinder gauge, and calculate the oil clearance.
3. If the oil clearance exceeds the allowable limit, replace the camshaft.

Oil clearance of camshaft journal	Factory specification	0.050 to 0.091 mm 0.0020 to 0.0035 in.
	Allowable limit	0.15 mm 0.0059 in.

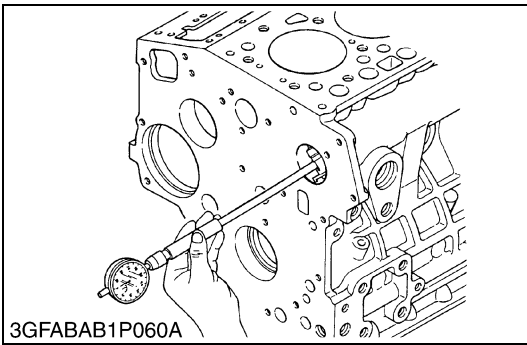

Camshaft journal O.D.	Factory specification	35.934 to 35.950 mm 1.4147 to 1.4153 in.
Camshaft bearing I.D. (Cylinder block bore I.D.)	Factory specification	36.000 to 36.025 mm 1.4173 to 1.4183 in.

9Y1210982ENS0094US0

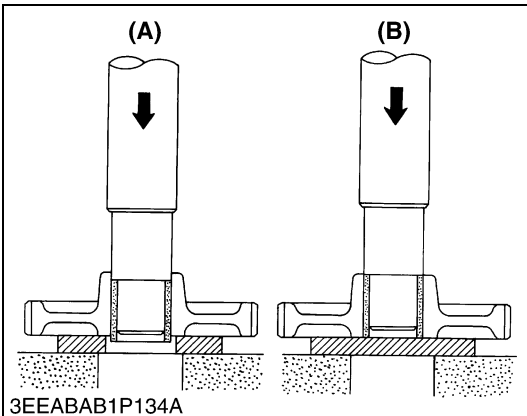

Replacing Idle Gear Bushing

(When removing)

1. Press out the used idle gear bushing using an idle gear bushing replacing tool. (See page "SPECIAL TOOLS".)

(When installing)

1. Clean a new idle gear bushing and idle gear bore, and apply engine oil to them.
2. Press in a new bushing using an idle gear bushing replacing tool, until it is flush with the end of the idle gear.

(A) When Removing

(B) When Installing

9Y1210982ENS0095US0

(3) Piston and Connecting Rod

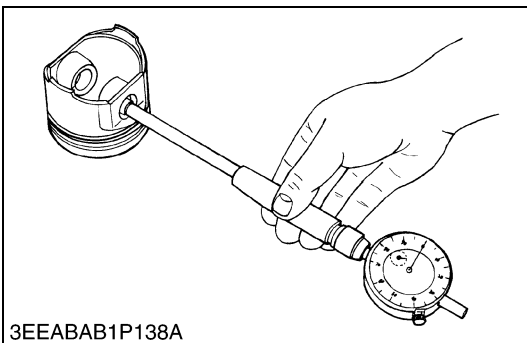

Piston Pin Bore I.D.

1. Measure the piston pin bore I.D. in both the horizontal and vertical directions with a cylinder gauge.
2. If the measurement exceeds the allowable limit, replace the piston.

Piston pin bore I.D.	Factory specification	22.000 to 22.013 mm 0.86615 to 0.86665 in.
	Allowable limit	22.03 mm 0.8673 in.

9Y1210982ENS0096US0

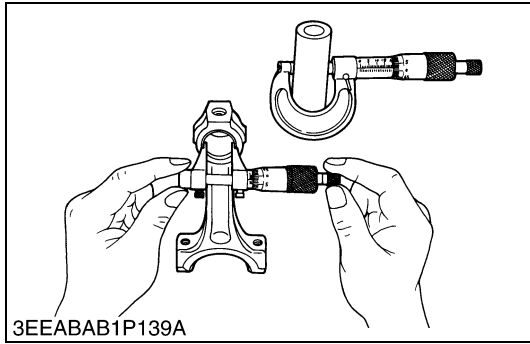

Oil Clearance between Piston Pin and Small End Bushing

1. Measure the piston pin O.D. where it contacts the bushing with an outside micrometer.
2. Measure the small end bushing I.D. with an inside micrometer, and calculate the oil clearance.
3. If the oil clearance exceeds the allowable limit, replace the bushing. If it still exceeds the allowable limit, replace the piston pin.

Oil clearance between piston pin and small end bushing	Factory specification	0.014 to 0.038 mm 0.00055 to 0.0014 in.
	Allowable limit	0.15 mm 0.0059 in.

Piston pin O.D.	Factory specification	22.002 to 22.011 mm 0.86622 to 0.86657 in.
-----------------	-----------------------	---

Small end bushing I.D.	Factory specification	22.025 to 22.040 mm 0.86713 to 0.86771 in.
------------------------	-----------------------	---

9Y1210982ENS0097US0

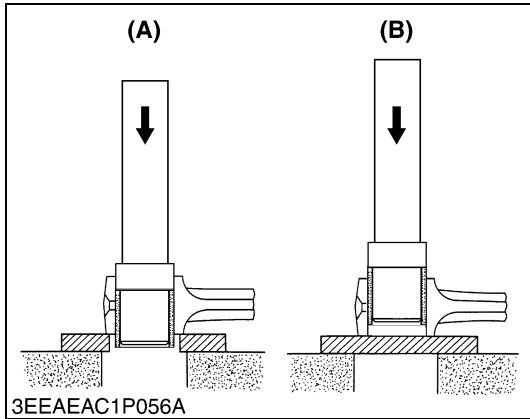

Replacing Small End Bushing

(When removing)

1. Press out the used bushing using a small end bushing replacing tool. (See page "SPECIAL TOOLS".)

(When installing)

1. Clean a new small end bushing and bore, and apply engine oil to them.
2. Using a small end bushing replacing tool, press in a new bushing (service parts) taking care to see that the connecting rod oil hole matches the bushing hole.

Oil clearance between piston pin and small end bushing (Spare parts)	Factory specification	0.014 to 0.038 mm 0.00056 to 0.0014 in.
	Allowable limit	0.15 mm 0.0059 in.

Small end bushing I.D. (Spare parts)	Factory specification	22.025 to 22.040 mm 0.86713 to 0.86771 in.
--------------------------------------	-----------------------	---

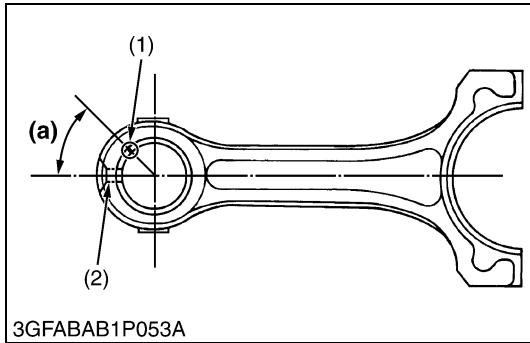

- (1) Seam
- (2) Oil Hole

- (A) When Removing**
- (B) When Installing**
- (a) 0.785 rad (45 °)**

9Y1210982ENS0098US0

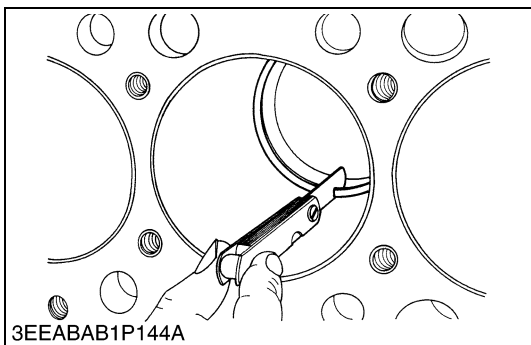

Piston Ring Gap

1. Insert the piston ring into the lower part of the cylinder (the least worn out part) with a piston.
2. Measure the ring gap with a thickness gauge.
3. If the measurement exceeds the allowable limit, replace the piston ring.

Piston ring gap [D1105, V1505]	Top ring	Factory specification	0.20 to 0.35 mm 0.0079 to 0.014 in.
		Allowable limit	1.20 mm 0.0472 in.
	Second ring	Factory specification	0.40 to 0.55 mm 0.016 to 0.021 in.
		Allowable limit	1.20 mm 0.0472 in.
	Oil ring	Factory specification	0.30 to 0.55 mm 0.012 to 0.021 in.
		Allowable limit	1.25 mm 0.0492 in.

Piston ring gap [D1305]	Top ring	Factory specification	0.15 to 0.25 mm 0.0059 to 0.0098 in.
		Allowable limit	1.20 mm 0.0472 in.
	Second ring	Factory specification	0.40 to 0.55 mm 0.016 to 0.021 in.
		Allowable limit	1.20 mm 0.0472 in.
	Oil ring	Factory specification	0.25 to 0.45 mm 0.0091 to 0.017 in.
		Allowable limit	1.25 mm 0.0492 in.

9Y1210982ENS0099US0

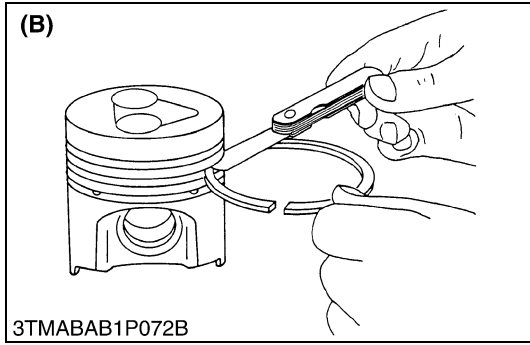
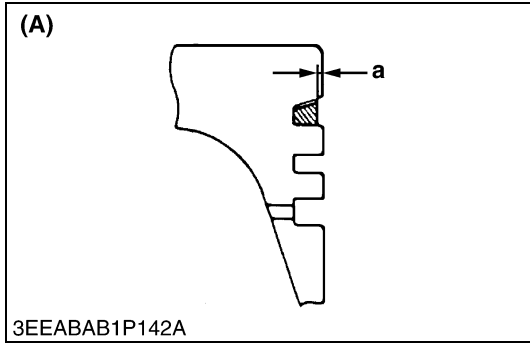

Clearance between Piston ring and Piston Ring Groove

1. Clean the rings and the ring grooves, and install each ring in its groove.
2. Measure the clearance between the ring and the groove with a feeler gauge or depth gauge.
3. If the clearance exceeds the allowable limit, replace the piston ring.
4. If the clearance still exceeds the allowable limit with new ring, replace the piston.

Clearance between piston ring and piston ring groove [D1105, V1505]	Second ring	Factory specification	0.0950 to 0.122 mm 0.00374 to 0.00480 in.
		Allowable limit	0.2 mm 0.008 in.
	Oil ring	Factory specification	0.020 to 0.060 mm 0.00079 to 0.0023 in.
		Allowable limit	0.15 mm 0.0059 in.
Clearance between piston ring and piston ring groove [D1305]	Second ring	Factory specification	0.0850 to 0.122 mm 0.00335 to 0.00480 in.
		Allowable limit	0.2 mm 0.008 in.
	Oil ring	Factory specification	0.02 to 0.06 mm 0.0008 to 0.002 in.
		Allowable limit	0.15 mm 0.0059 in.

Factory specification : a [D1105, V1505]	More than 0.2 mm 0.008 in.
--	----------------------------------

(A) Top Ring (Key Stone Type)

(B) 2nd, Oil Ring

9Y1210982ENS0100US0

Connecting Rod Alignment

1. Remove the crankpin bearing, and install the connecting rod cap.
2. Install the piston pin in the connecting rod.
3. Install the connecting rod on the connecting rod alignment tool.
4. Put a gauge over the piston pin, and move it against the face plate.
5. If the gauge does not fit squarely against the face plate, measure the space between the pin of the gauge and the face plate.
6. If the measurement exceeds the allowable limit, replace the connecting rod.

Space between gauge pin face plate	Allowable limit	0.05 mm 0.002 in.
------------------------------------	-----------------	----------------------

9Y1210982ENS0101US0

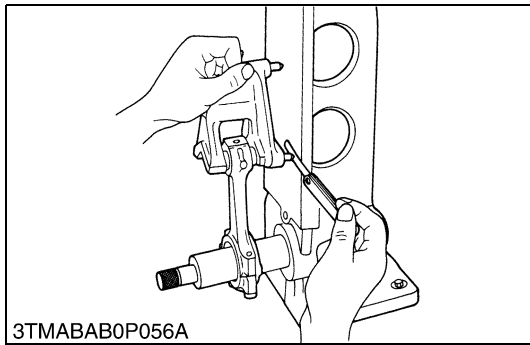

(4) Crankshaft

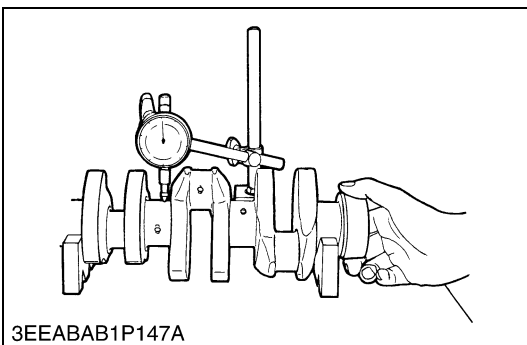
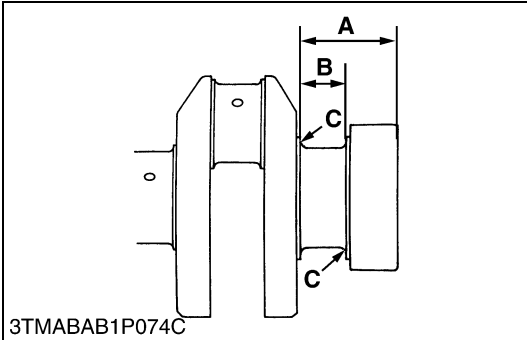
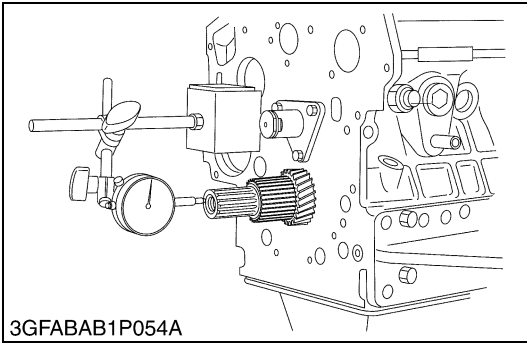

Crankshaft Side Clearance

1. Set a dial indicator with its tip on the end of the crankshaft.
2. Measure the side clearance by moving the crankshaft to the front and rear.
3. If the measurement exceeds the allowable limit, replace the thrust bearings.
4. If the same size bearing is useless because of the crankshaft journal wear, replace it with an oversize one referring to the table and figure.

Crankshaft side clearance	Factory specification	0.15 to 0.31 mm 0.0059 to 0.012 in.
	Allowable limit	0.50 mm 0.020 in.

(Reference)

- Oversize dimensions of crankshaft journal

Oversize	0.20 mm 0.0079 in.	0.40 mm 0.016 in.
Dimension A	51.50 to 51.70 mm 2.028 to 2.035 in.	51.60 to 51.80 mm 2.032 to 2.039 in.
Dimension B	28.20 to 28.25 mm 1.111 to 1.112 in.	28.40 to 28.45 mm 1.119 to 1.120 in.
Dimension C	2.3 to 2.7 mm radius 0.091 to 0.10 in. radius	2.3 to 3.7 mm radius 0.091 to 0.10 in. radius

The crankshaft journal must be fine-finished to higher than Rmax = 0.8S.

9Y1210982ENS0102US0

Crankshaft Alignment

1. Support the crankshaft with V blocks on the surface plate at both end journals.
2. Set a dial indicator with its tip on the intermediate journal.
3. Measure the crankshaft alignment.
4. If the measurement exceeds the allowable limit, replace the crankshaft.

Crankshaft alignment	Allowable limit	0.02 mm 0.0008 in.
----------------------	-----------------	-----------------------

9Y1210982ENS0103US0

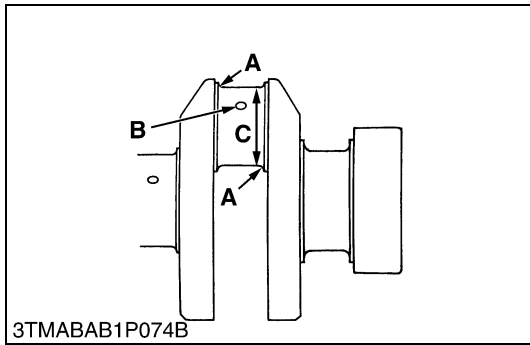
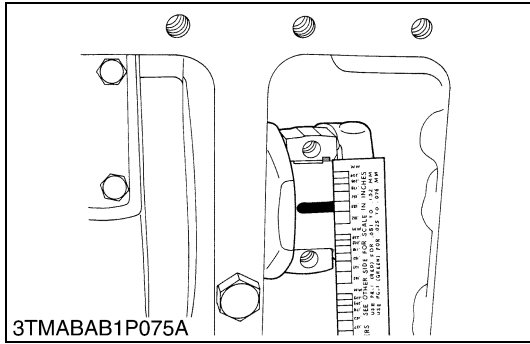

Oil Clearance between Crankpin and Crankpin Bearing

1. Clean the crankpin and crankpin bearing.
2. Put a strip of plastigauge on the center of the crankpin.
3. Install the connecting rod cap and tighten the connecting rod screws to the specified torque, and remove the cap again.
4. Measure the amount of the flattening with the scale, and get the oil clearance.
5. If the oil clearance exceeds the allowable limit, replace the crankpin bearing.
6. If the same size bearing is useless because of the crankpin wear, replace it with an undersize one referring to the table and figure.

NOTE

- Never insert the plastigauge into the crankpin oil hole.
- Be sure not to move the crankshaft while the connecting rod screws are tightened.

Oil clearance between crankpin and crankpin bearing	Factory specification	0.029 to 0.091 mm 0.0011 to 0.0036 in.
	Allowable limit	0.20 mm 0.0079 in.

Crankpin O.D.	Factory specification	39.959 to 39.975 mm 1.5732 to 1.5738 in.
Crankpin bearing I.D.	Factory specification	40.004 to 40.050 mm 1.5750 to 1.5767 in.

(Reference)

- Undersize dimensions of crankpin

Undersize	0.20 mm 0.0079 in.	0.40 mm 0.016 in.
Dimension A	2.8 to 3.2 mm radius 0.11 to 0.12 in. radius	2.8 to 3.2 mm radius 0.11 to 0.12 in. radius
*Dimension B	1.0 to 1.5 mm relief 0.040 to 0.059 in. relief	1.0 to 1.5 mm relief 0.040 to 0.059 in. relief
Dimension C	39.759 to 39.775 mm dia. 1.5654 to 1.5659 in. dia.	39.559 to 39.575 mm dia. 1.5575 to 1.5580 in. dia.

The crankpin must be fine-finished to higher than Rmax = 0.8S.
 *Holes to be de-burred and edges rounded with 1.0 to 1.5 mm (0.040 to 0.059 in.) relief.

9Y1210982ENS0104US0

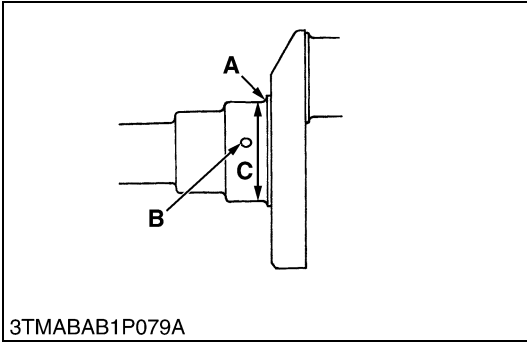
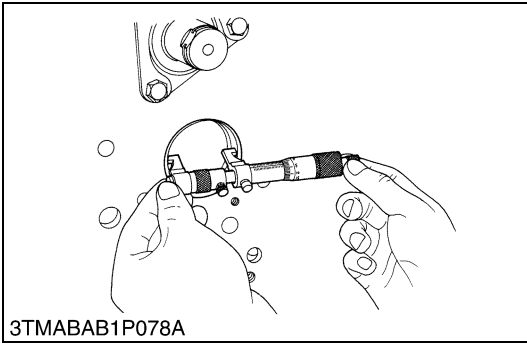
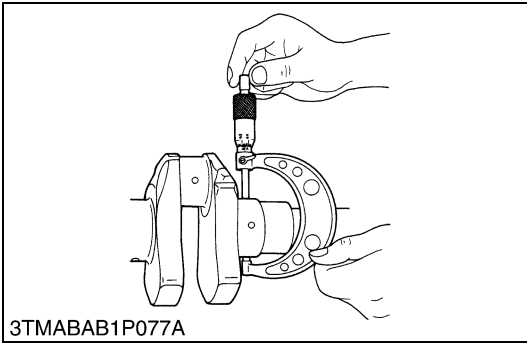

Oil Clearance between Crankshaft Journal and Crankshaft Bearing 1

1. Measure the O.D. of the crankshaft front journal with an outside micrometer.
2. Measure the I.D. of the crankshaft bearing 1 with an inside micrometer, and calculate the oil clearance.
3. If the clearance exceeds the allowable limit, replace the crankshaft bearing 1.
4. If the same size bearing is useless because of the crankshaft journal wear, replace it with an undersize one referring to the table and figure.

[D1105, V1505]

Oil clearance between crankshaft journal and crankshaft bearing 1	Factory specification	0.0340 to 0.114 mm 0.00134 to 0.00448 in.
	Allowable limit	0.20 mm 0.0079 in.

Crankshaft journal O.D.	Factory specification	47.934 to 47.950 mm 1.8872 to 1.8877 in.
Crankshaft bearing 1 I.D.	Factory specification	47.984 to 48.048 mm 1.8892 to 1.8916 in.

(Reference)

- Undersize dimensions of crankshaft journal

Undersize	0.20 mm 0.0079 in.	0.40 mm 0.016 in.
Dimension A	2.3 to 2.7 mm radius 0.091 to 0.10 in. radius	2.3 to 2.7 mm radius 0.091 to 0.10 in. radius
*Dimension B	1.0 to 1.5 mm relief 0.040 to 0.059 in. relief	1.0 to 1.5 mm relief 0.040 to 0.059 in. relief
Dimension C	47.734 to 47.750 mm dia. 1.8793 to 1.8799 in. dia.	47.534 to 47.550 mm dia. 1.8715 to 1.8720 in. dia.

The crankshaft journal must be fine-finished to higher than Rmax = 0.8S.
 *Holes to be de-burred and edges rounded with 1.0 to 1.5 mm (0.040 to 0.059 in.) relief.

[D1305]

Oil clearance between crankshaft journal and crankshaft bearing 1	Factory specification	0.0340 to 0.119 mm 0.00134 to 0.00468 in.
	Allowable limit	0.20 mm 0.0079 in.

Crankshaft journal O.D.	Factory specification	51.921 to 51.940mm 2.0442 to 2.0448 in.
Crankshaft bearing 1 I.D.	Factory specification	51.974 to 52.040 mm 2.0463 to 2.0488 in.

(Reference)

- Undersize dimensions of crankshaft journal

Undersize	0.20 mm 0.0079 in.	0.40 mm 0.016 in.
Dimension A	2.3 to 2.7 mm radius 0.091 to 0.10 in. radius	2.3 to 2.7 mm radius 0.091 to 0.10 in. radius
*Dimension B	1.0 to 1.5 mm relief 0.040 to 0.059 in. relief	1.0 to 1.5 mm relief 0.040 to 0.059 in. relief
Dimension C	51.721 to 51.740 mm dia. 2.0363 to 2.0370 in. dia.	51.521 to 51.540 mm dia. 2.0284 to 2.0291 in. dia.

The crankshaft journal must be fine-finished to higher than Rmax = 0.8S.
 *Holes to be de-burred and edges rounded with 1.0 to 1.5 mm (0.040 to 0.059 in.) relief.

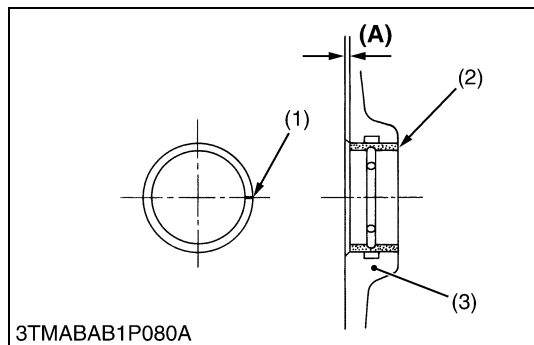

Replacing Crankshaft Bearing 1

(When removing)

1. Press out the used crankshaft bearing 1 using a crankshaft bearing 1 replacing tool. (See page "SPECIAL TOOLS".)

(When installing)

1. Clean a new crankshaft bearing 1 and crankshaft journal bore, and apply engine oil to them.
2. Using a crankshaft bearing 1 replacing tool, press in a new bearing 1 (2) so that its seam (1) directs toward the exhaust manifold side. (See figure.)

Dimension (A)	Factory specification	0 to 0.3 mm 0 to 0.01 in.
---------------	-----------------------	------------------------------

- (1) Seam
- (2) Crankshaft Bearing 1

- (3) Cylinder Block
- (A) Dimension**

9Y1210982ENS0106US0

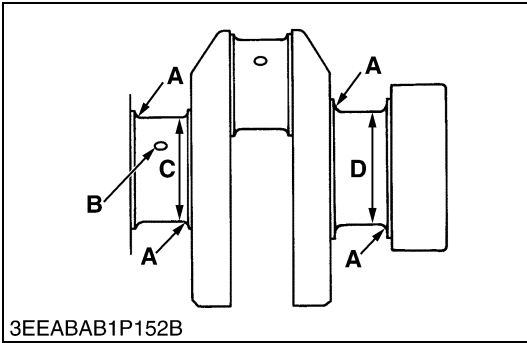
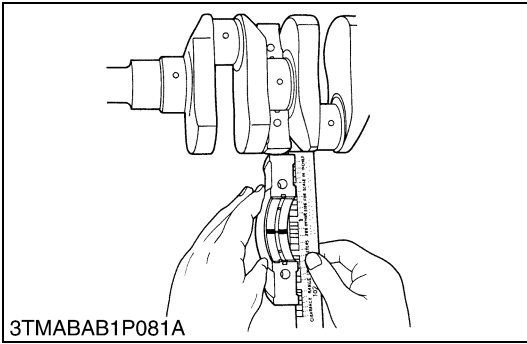

Oil Clearance between Crankshaft Journal and Crankshaft Bearing 2 (Crankshaft Bearing 3)

1. Put a strip of plastigauge on the center of the journal.
2. Install the bearing case and tighten the bearing case screws 1 to the specified torque, and remove the bearing case again.
3. Measure the amount of the flattening with the scale and get the oil clearance.
4. If the clearance exceeds the allowable limit, replace the crankshaft bearing 2 (1) and crankshaft bearing (3).
5. If the same size bearing is useless because of the crankshaft journal wear, replace it with an undersize one referring to the table and figure.

■ **NOTE**

- Be sure not to move the crankshaft while the bearing case screws are tightened.

[D1105, V1505]

Oil clearance between crankshaft journal and crankshaft bearing 2	Factory specification	0.034 to 0.095 mm 0.0014 to 0.0037 in.
	Allowable limit	0.20 mm 0.0079 in.

Crankshaft journal O.D. (Intermediate)	Factory specification	47.934 to 47.950 mm 1.8872 to 1.8877 in.
Crankshaft bearing 2 I.D.	Factory specification	47.984 to 48.029 mm 1.8892 to 1.8909 in.

Oil clearance between crankshaft journal and crankshaft bearing 3	Factory specification	0.0340 to 0.103 mm 0.00134 to 0.00405 in.
	Allowable limit	0.20 mm 0.0079 in.

Crankshaft journal O.D. (Flywheel side)	Factory specification	51.921 to 51.940 mm 2.0442 to 2.0448 in.
Crankshaft bearing 3 I.D.	Factory specification	51.974 to 52.024 mm 2.0463 to 2.0481 in.

(Reference)

- Undersize dimensions of crankshaft journal

Undersize	0.020 mm 0.0079 in.	0.40 mm 0.016 in.
Dimension A	2.3 to 2.7 mm radius 0.091 to 0.10 in. radius	2.3 to 2.7 mm radius 0.091 to 0.10 in. radius
*Dimension B	1.0 to 1.5 mm relief 0.040 to 0.0591 in. relief	1.0 to 1.5 mm relief 0.040 to 0.0591 in. relief
Dimension C	47.734 to 47.750 mm dia. 1.8793 to 1.8799 in. dia.	47.534 to 47.550 mm dia. 1.8715 to 1.8720 in. dia.
Dimension D	51.721 to 51.740 mm dia. 2.0363 to 2.0370 in. dia.	51.521 to 51.540 mm dia. 2.0284 to 2.0291 in. dia.

The crankshaft journal must be fine-finished to higher than Rmax = 0.8S
 *Holes to be de-burred and edges rounded with 1.0 to 1.5 mm (0.040 to 0.059 in.) relief.

(To be continued)

(Continued)

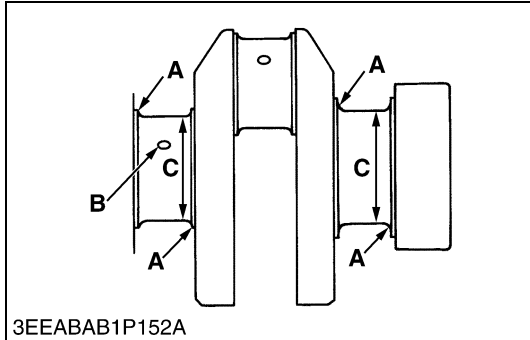
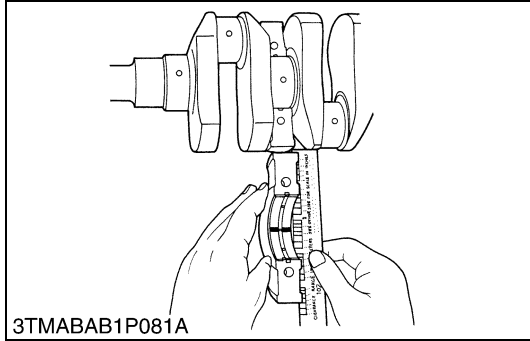

[D1305]

Oil clearance between crankshaft journal and crankshaft bearing 2	Factory specification	0.0340 to 0.103 mm 0.00134 to 0.00405 in.
	Allowable limit	0.20 mm 0.0079 in.

Crankshaft journal O.D. (Intermediate)	Factory specification	51.921 to 51.940 mm 2.0442 to 2.0448 in.
--	-----------------------	---

Crankshaft bearing 2 I.D.	Factory specification	51.974 to 52.024 mm 2.0463 to 2.0481 in.
---------------------------	-----------------------	---

Oil clearance between crankshaft journal and crankshaft bearing 3	Factory specification	0.0340 to 0.103 mm 0.00134 to 0.00405 in.
	Allowable limit	0.20 mm 0.0079 in.

Crankshaft journal O.D. (Flywheel side)	Factory specification	51.921 to 51.940 mm 2.0442 to 2.0448 in.
---	-----------------------	---

Crankshaft bearing 3 I.D.	Factory specification	51.974 to 52.024 mm 2.0463 to 2.0481 in.
---------------------------	-----------------------	---

(Reference)

- Undersize dimensions of crankshaft journal

Undersize	0.020 mm 0.0079 in.	0.40 mm 0.016 in.
Dimension A	2.3 to 2.7 mm radius 0.091 to 0.10 in. radius	2.3 to 2.7 mm radius 0.091 to 0.10 in. radius
*Dimension B	1.0 to 1.5 mm relief 0.040 to 0.0591 in. relief	1.0 to 1.5 mm relief 0.040 to 0.0591 in. relief
Dimension C	51.721 to 51.740 mm dia. 2.0363 to 2.0370 in. dia.	51.521 to 51.540 mm dia. 2.0284 to 2.0291 in. dia.

The crankshaft journal must be fine-finished to higher than Rmax = 0.8S
 *Holes to be de-burred and edges rounded with 1.0 to 1.5 mm (0.040 to 0.059 in.) relief.

9Y1210982ENS0107US0

(5) Cylinder

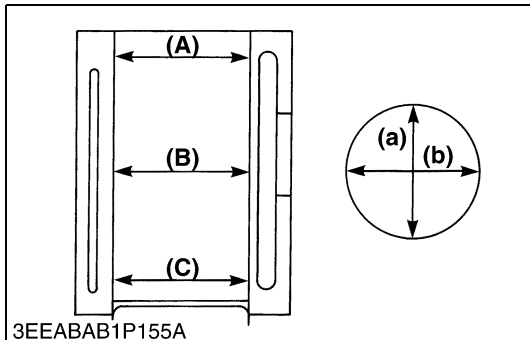
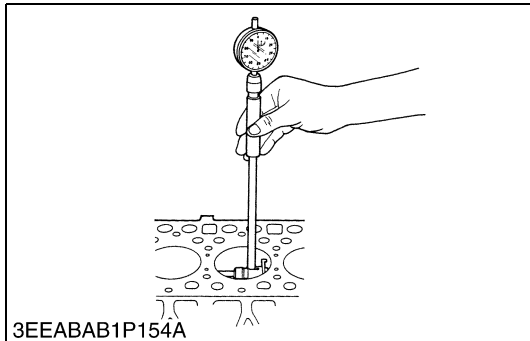

Cylinder Wear

1. Measure the I.D. of the cylinder at the six positions (see figure) with a cylinder gauge to find the maximum and minimum I.D.'s.
2. Get the difference (Maximum wear) between the maximum and the minimum I.D.'s.
3. If the wear exceeds the allowable limit, bore and hone to the oversize dimension. (Refer to "Correcting Cylinder".)
4. Visually check the cylinder wall for scratches. If deep scratches are found, the cylinder should be bored. (Refer to "Correcting Cylinder".)

Cylinder I.D.	Factory specification	78.000 to 78.019 mm 3.0709 to 3.0716 in.
	Allowable limit	78.15 mm 3.077 in.

- (A) Top
- (B) Middle
- (C) Bottom (Skirt)

- (a) Right-angled to Piston Pin
- (b) Piston Pin Direction

9Y1210982ENS0108US0

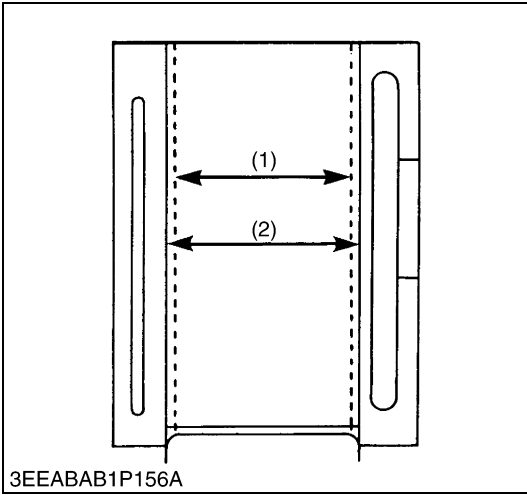

Correcting Cylinder

1. When the cylinder is worn beyond the allowable limit, bore and hone it to the specified dimension.

Oversized cylinder liner I.D.	Factory specification	78.500 to 78.519 mm 3.0906 to 3.0912 in.
	Allowable limit	78.65 mm 3.096 in.
Finishing	Finishing Hone to 1.2 to 2.0 mm μ R max. (48 to 78 in. μ R max.)	

2. Replace the piston and piston rings with oversize ones.
Oversize: 0.5 mm (0.02 in.)

■ **NOTE**

- When the oversize cylinder is worn beyond the allowable limit, replace the cylinder block with a new one.

(1) Cylinder I.D. (Before Correction) (2) Cylinder I.D. (Oversize)

9Y1210982ENS0109US0

(6) Oil Pump

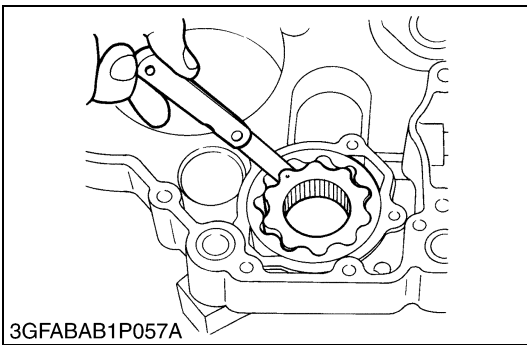

Rotor Lobe Clearance

1. Measure the clearance between lobes of the inner rotor and the outer rotor with a feeler gauge.
2. If the clearance exceeds the factory specifications, replace the oil pump rotor assembly.

Rotor lobe clearance	Factory specification	0.060 to 0.18 mm 0.0024 to 0.0071 in.
----------------------	-----------------------	--

9Y1210982ENS0110US0

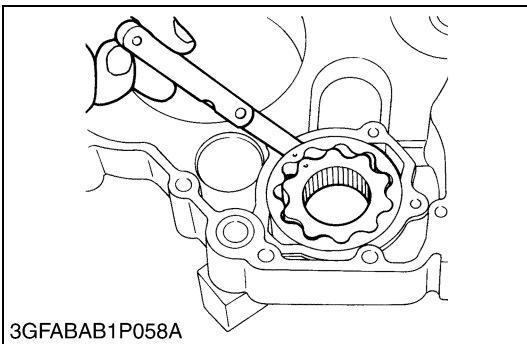

Clearance between Outer Rotor and Pump Body

1. Measure the clearance between the outer rotor and the pump body with a feeler gauge.
2. If the clearance exceeds the factory specifications, replace the oil pump rotor assembly.

Clearance between outer rotor and pump body	Factory specification	0.100 to 0.180 mm 0.00394 to 0.00708 in.
---	-----------------------	---

9Y1210982ENS0111US0

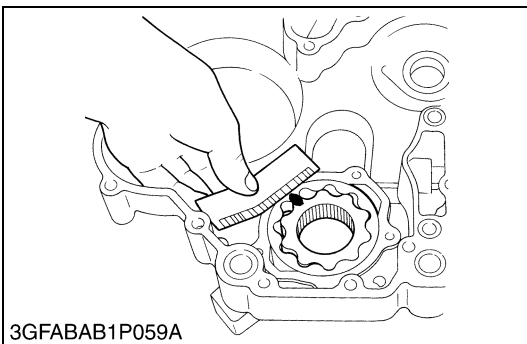

Clearance between Rotor and Cover

1. Put a strip of plastigauge onto the rotor face with grease.
2. Install the cover and tighten the screws.
3. Remove the cover carefully, and measure the amount of the flattening with the scale and get the clearance.
4. If the clearance exceeds the factory specifications, replace the oil pump rotor assembly.

Clearance between rotor and cover	Factory specification	0.025 to 0.075 mm 0.00099 to 0.0029 in.
-----------------------------------	-----------------------	--

9Y1210982ENS0112US0

2 CLUTCH

MECHANISM

CONTENTS

1. STRUCTURE.....	2-M1
[1] MANUAL TRANSMISSION MODEL	2-M1
[2] CLUTCH OPERATION	2-M2
(1) Clutch "Engaged"	2-M2
(2) Clutch "Disengaged"	2-M2

1. STRUCTURE

[1] MANUAL TRANSMISSION MODEL

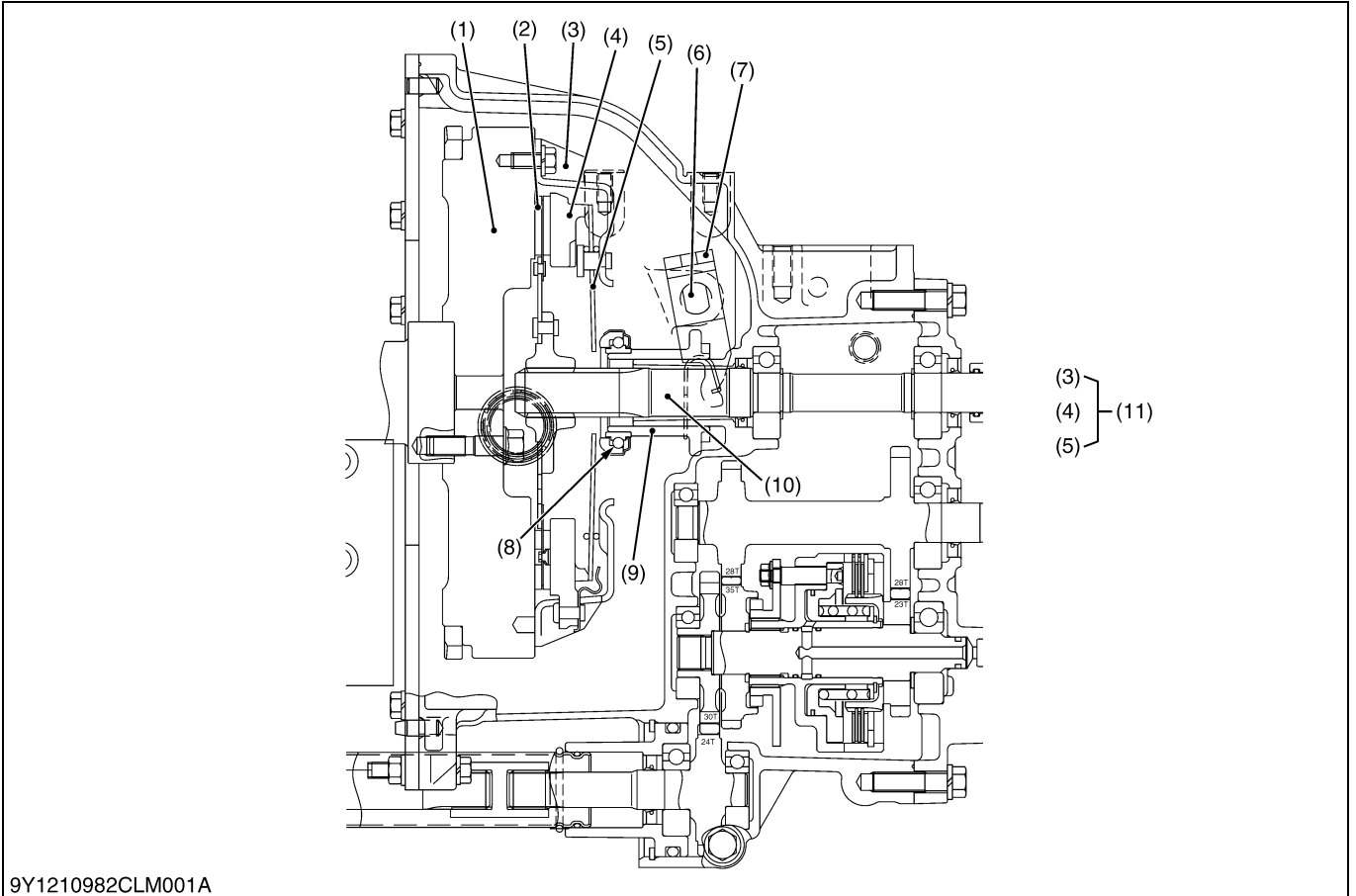

9Y1210982CLM001A

- | | | | |
|---------------------|----------------------|----------------------------|------------------------------|
| (1) Engine Flywheel | (4) Pressure Plate | (7) Clutch Release Fork | (10) Clutch Shaft |
| (2) Clutch Disc | (5) Diaphragm Spring | (8) Clutch Release Bearing | (11) Pressure Plate Assembly |
| (3) Clutch Cover | (6) Clutch Rod | (9) Clutch Release Hub | |

Engine torque is transmitted to the pressure plate assembly (11) via the flywheel (1) which is connected to the engine crankshaft. Therefore, the clutch cover constantly operates with engine. The clutch disc (2) is located between the flywheel (1) and the pressure plate (4) of pressure plate assembly (11). Torque is transmitted to the clutch disc (2) by the pressure created by the diaphragm spring (5) installed in the pressure plate assembly (11). Then, the torque is transmitted to the transmission via the clutch shaft (10).

When the clutch pedal is depressed, the clutch release hub (9) and the clutch release bearing (8) move towards the flywheel and push the fingers of the diaphragm spring (5). This movement pulls the pressure plate (4) up and disengages the clutch.

9Y1210982CLM0001US0

[2] CLUTCH OPERATION

(1) Clutch "Engaged"

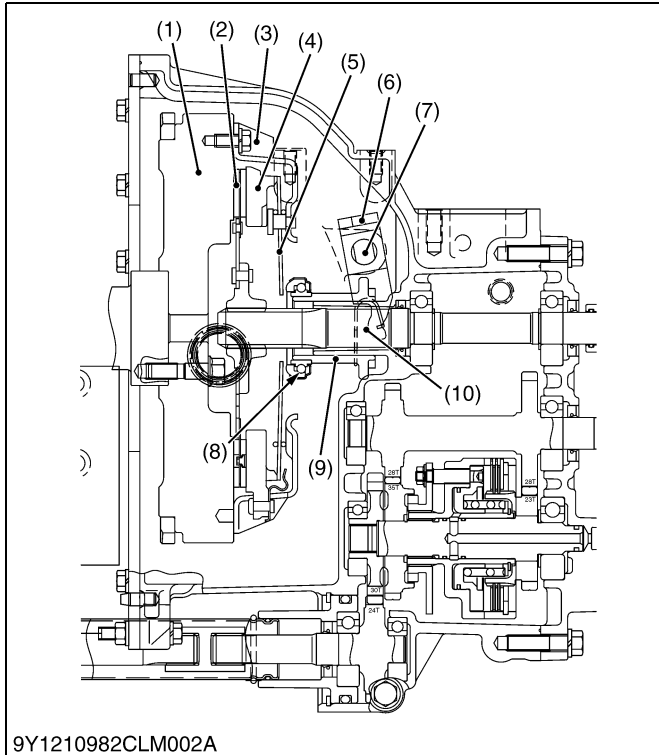

9Y1210982CLM002A

When the clutch pedal is not depressed, the clutch release bearing (8) and the fingers of the diaphragm spring (5) are not connected to each other.

Accordingly, the pressure plate (4) is tightly pressed against the flywheel (1) by the diaphragm spring (5).

As a result, rotation of the flywheel (1) is transmitted to the transmission through the clutch shaft (10) due to the frictional force among the flywheel (1), the clutch disc (2) and the pressure plate (4).

- | | |
|----------------------|---------------------|
| (1) Flywheel | (6) Release Fork |
| (2) Clutch Disc | (7) Clutch Rod |
| (3) Clutch Cover | (8) Release Bearing |
| (4) Pressure Plate | (9) Release Hub |
| (5) Diaphragm Spring | (10) Clutch Shaft |

9Y1210982CLM0002US0

(2) Clutch "Disengaged"

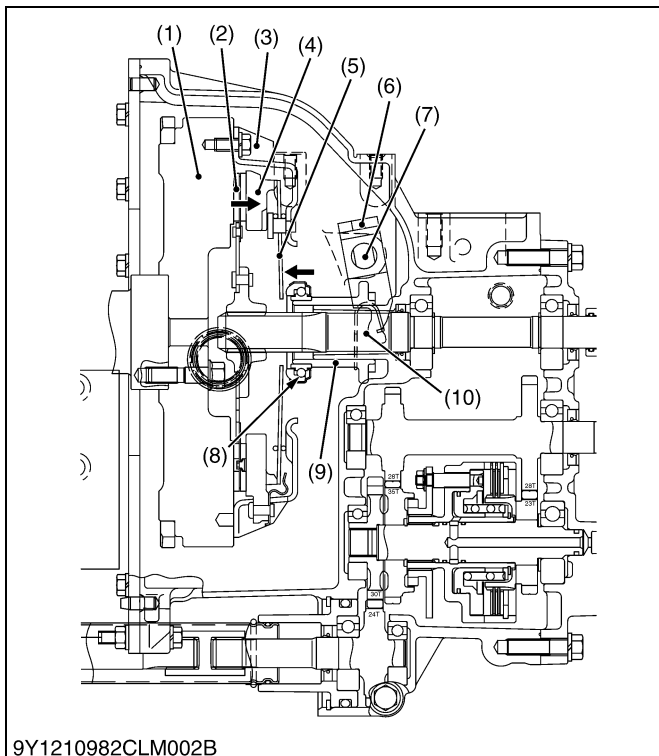

9Y1210982CLM002B

When the clutch pedal is depressed, the clutch pedal rod is pulled to move the clutch rod (7). Then, the release fork (6) pushes the release hub (9) and release bearing (8) toward the flywheel. Simultaneously, the release bearing (8) pushes the diaphragm spring (5).

As the pressure plate (4) is pulled by the diaphragm spring (5), the frictional force among the flywheel (1), the clutch disc (2) and the pressure plate (4) disappears.

Therefore, rotation of the flywheel (1) is not transmitted to the clutch disc (2), and then the rotation of the clutch shaft (10) stops.

- | | |
|----------------------|---------------------|
| (1) Flywheel | (6) Release Fork |
| (2) Clutch Disc | (7) Clutch Rod |
| (3) Clutch Cover | (8) Release Bearing |
| (4) Pressure Plate | (9) Release Hub |
| (5) Diaphragm Spring | (10) Clutch Shaft |

9Y1210982CLM0003US0

SERVICING

CONTENTS

1. TROUBLESHOOTING.....	2-S1
2. SERVICING SPECIFICATIONS.....	2-S2
3. TIGHTENING TORQUES.....	2-S3
4. CHECKING, DISASSEMBLING AND SERVICING.....	2-S4
[1] CHECKING AND ADJUSTING.....	2-S4
[2] DISASSEMBLING AND ASSEMBLING.....	2-S5
(1) Separating Engine From Clutch housing.....	2-S5
(2) Separating Clutch Assembly.....	2-S8
[3] SERVICING.....	2-S9

1. TROUBLESHOOTING

Symptom	Probable Cause and Checking Procedure	Solution	Reference Page
Clutch Drags	1. Clutch pedal free travel excessive	Adjust clutch pedal	2-S4
	2. Dust on clutch disc generated from clutch disc facing	Remove dust	2-S8
	3. Release fork broken	Replace release fork	2-S8
	4. Clutch disc or pressure plate warped	Replace clutch disc or pressure plate assembly	2-S8
	5. Wire ring of the pressure plate worn or broken	Replace pressure plate assembly	2-S8
Clutch Slips	1. Clutch pedal free travel too small	Adjust clutch pedal	2-S4
	2. Clutch disc excessively worn	Replace clutch disc	2-S8
	3. Grease or oil on clutch disc facing	Replace clutch disc	2-S8
	4. Clutch disc or pressure plate warped	Replace clutch disc or pressure plate assembly	2-S8
	5. Diaphragm spring weaken or broken	Replace pressure plate assembly	2-S8
	6. Wire ring of the pressure plate worn or broken	Replace pressure plate assembly	2-S8
Chattering	1. Grease or oil on clutch disc facing	Replace clutch disc	2-S8
	2. Clutch disc or pressure plate warped	Replace clutch disc or pressure plate assembly	2-S8
	3. Clutch disc boss spline worn or rusted	Replace clutch disc or remove rust	2-S8
	4. Clutch shaft bent or spline worn	Replace clutch disc	2-S8
	5. Pressure plate or flywheel face cracked or scored	Replace pressure plate assembly or flywheel	2-S8
	6. Diaphragm spring strength uneven or diaphragm spring broken	Replace pressure plate assembly	2-S8
Rattle During Running	1. Clutch disc boss spline worn	Replace clutch disc	2-S8
	2. Bearing worn or sticking	Replace bearing	2-S8
Clutch Squeaks	1. Bearing sticking or dry	Replace bearing	2-S8
	2. Clutch disc excessively worn	Replace clutch disc	2-S8
Vibration	1. Clutch shaft bent	Replace clutch shaft	2-S8
	2. Clutch disc rivet worn or broken	Replace clutch disc	2-S8
	3. Clutch parts broken	Replace clutch parts	2-S8

9Y1210982CLS0001US0

2. SERVICING SPECIFICATIONS

Item		Factory Specification	Allowable Limit
Clutch Pedal	Free Travel	10 to 17 mm 0.40 to 0.66 in.	–
Clearance between Bolt and Housing Case	Clearance "B"	Approx. 8.5 mm 0.33 in.	–
Clutch Disc and Clutch Shaft	Backlash (Displacement around Disc Edge)	–	2.0 mm 0.079 in.
Clutch Disc	Disc Surface to Rivet Top	–	0.3 mm 0.012 in.
Pressure Plate	Flatness	–	0.2 mm 0.008 in.

9Y1210982CLS0002US0

3. TIGHTENING TORQUES

Tightening torques of screws, bolts and nuts on the table below are especially specified.
(For general use screws, bolts and nuts: Refer to G-10.)

Item	N·m	kgf·m	lbf·ft
Steering wheel mounting nut	20 to 40	2.1 to 4.0	15 to 29
Clutch mounting screw	23.5 to 27.5	2.4 to 2.8	17.4 to 20.2

9Y1210982CLS0003US0

4. CHECKING, DISASSEMBLING AND SERVICING

[1] CHECKING AND ADJUSTING

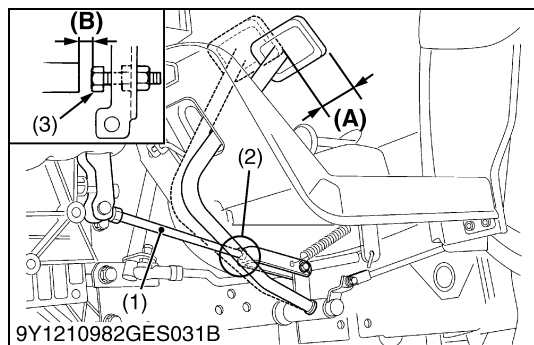

Checking Clutch Pedal Free Travel

CAUTION

- When checking, park the tractor on flat ground, apply the parking brake, stop the engine and remove the key.
1. Slightly depress the clutch pedal and measure stroke **(A)** at the top of pedal stroke.
 2. If the measurement is not within the factory specifications, loosen the lock nut **(2)** and adjust the clutch pedal rod **(1)** length.
 3. Retighten the lock nut **(2)**.
 4. After adjusting, release the clutch pedal and check the clearance **(B)**. If adjustment is needed, adjust the clearance with the bolt **(3)**.

Clutch pedal free travel (A)	Factory specification	10 to 17 mm 0.40 to 0.66 in.
Clearance (B)	Factory specification	Approximately 8.5 mm 0.33 in.

- (1) Clutch Pedal Rod
- (2) Lock Nut
- (3) Bolt

- (A) Clutch pedal free travel**
- (B) Clearance between bolt and housing case**

9Y1210982CLS0004US0

[2] DISASSEMBLING AND ASSEMBLING

(1) Separating Engine From Clutch housing

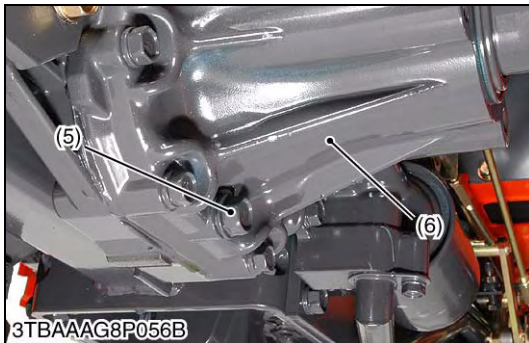
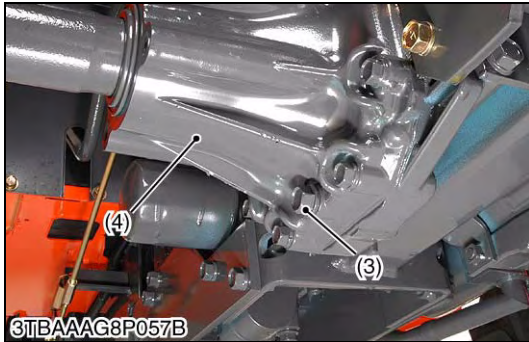
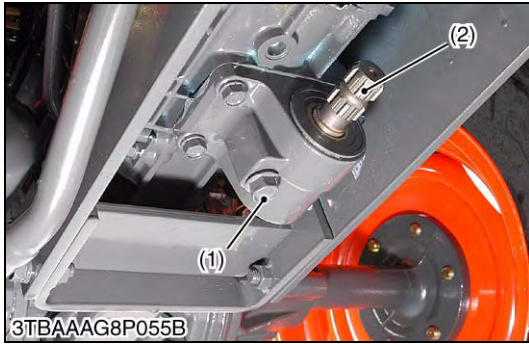

Draining Transmission Fluid

⚠ CAUTION

- Stop the engine before checking and changing the transmission fluid.

1. Place the oil pan under the tractor.
2. Remove the drain plugs (1), (3), (5) at the mid-PTO shaft and at the bottom of the rear axle cases (4), (6).
3. Drain the transmission fluid.
4. After draining the transmission fluid, reinstall the drain plugs (1), (3), (5).

■ IMPORTANT

- Use only KUBOTA UDT oil. Use of other oils may damage the transmission or hydraulic system. Refer to G-8.
- Never work the tractor immediately after changing the transmission oil. Keep the engine at medium speed for a few minutes to prevent damage to the transmission.
- Do not mix different brands oil together.

Transmission fluid capacity	B2050, B2350, B2650 Manual transmission	16.5 L 4.4 U.S.gals 3.6 Imp.gals
	B2350HST B2650HST B3150HST	17 L 4.5 U.S.gals 3.7 Imp.gals

- | | |
|-------------------|---------------------------|
| (1) Drain Plug | (4) Rear Axle Case (L.H.) |
| (2) Mid-PTO Shaft | (5) Drain Plug |
| (3) Drain Plug | (6) Rear Axle Case (R.H.) |

9Y1210982ENS0024US0

Bonnet, Side Cover and Battery Cord

1. Open the bonnet (1).
2. Disconnect the battery negative cord.
3. Disconnect the head light connectors and remove the bonnet (1) side covers (2).

■ NOTE

- When disconnecting the battery cords, disconnect the grounding cord first. When connecting, positive cord first.

- | | |
|----------------|-------------|
| (1) Bonnet | (3) Battery |
| (2) Side Cover | |

9Y1210982CLS0006US0

Hydraulic Hoses from Power Steering Cylinder

1. Disconnect the hydraulic hoses (1), (3) from the power steering cylinder (2).
2. Removing the snap pin (4) and disconnect the bi-speed rod (5).

- (1) Hydraulic Hose (R.H.)
- (2) Power Steering Cylinder
- (3) Hydraulic Hose (L.H.)
- (4) Snap Pin
- (5) Bi-Speed Rod

[A] Bi-Speed Turn Model

9Y1210982CLS0007US0

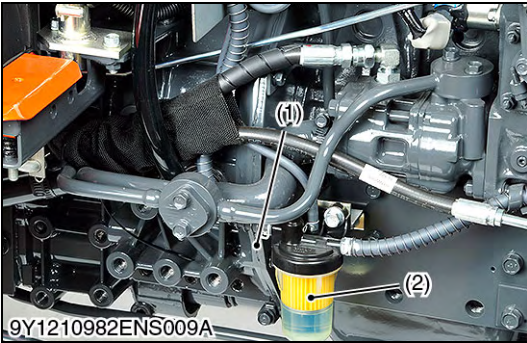
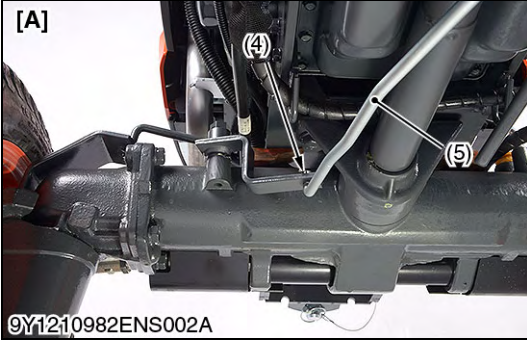
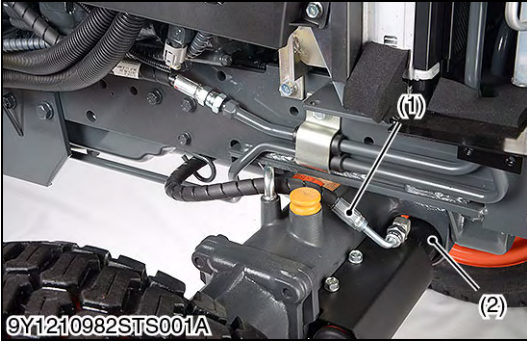

Fuel

1. Disconnect the fuel hose (1) from the fuel filter (2).
2. Drain the fuel to the fuel tank completely.

- (1) Fuel Hose (from Fuel Tank)
- (2) Fuel Filter

9Y1210982CLS0008US0

Wiring Harness, Plate, Stay and Clamp (Left Side)

1. Disconnect the wiring harness (1) from battery, alternator, engine and starter.
2. Remove the plate (2).
3. Remove the stay (3) and clamp (4).

- (1) Wiring Harness
- (2) Plate
- (3) Stay
- (4) Clamp

9Y1210982CLS0010US0

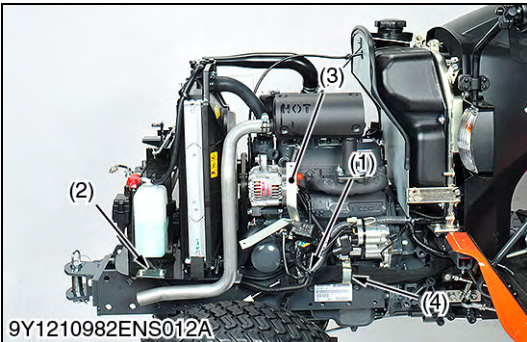

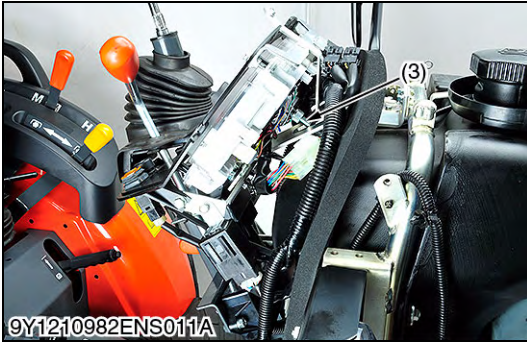
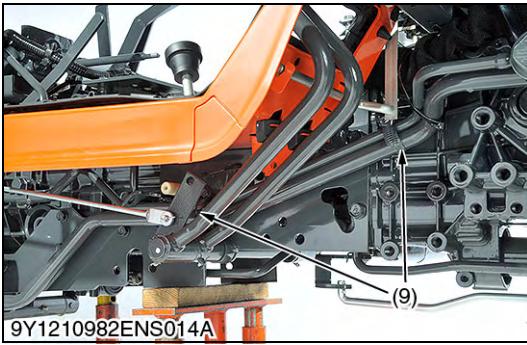
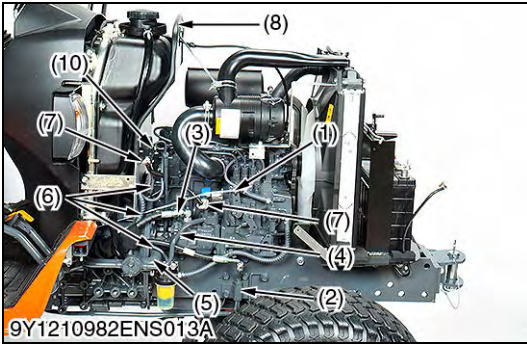

Accelerator Rod, Power Steering Hose, Fuel Hoses, Connectors and Others (Right Side)

1. Disconnect the accelerator rod (1).
2. Remove the clamp (2).
3. Disconnect the power steering hose (3), hydraulic delivery pipe (4) and hydraulic inlet hose (5).
4. Disconnect the fuel hoses (6).
5. Disconnect the connectors (7) and glow plug harness (10).
6. Remove the shuttle plate (8).
7. Loosen the clamp (9).

- | | |
|-----------------------------|------------------------|
| (1) Accelerator Rod | (6) Fuel Hose |
| (2) Clamp | (7) Connector |
| (3) Power Steering Hose | (8) Shuttle Plate |
| (4) Hydraulic Delivery Pipe | (9) Clamp |
| (5) Hydraulic Inlet Hose | (10) Glow Plug Harness |

9Y1210982CLS0022US0

Steering Wheel, Meter Panel, Shuttle Lever and Panel Lower Cover

1. Remove the steering wheel cap.
2. Remove the steering wheel mounting nut.
3. Remove the steering wheel with a steering wheel puller (Code No. 07916-51090).
4. Remove the shuttle lever (2). (If equipped)
5. Disconnect the wiring harness connector of key switch.
6. Remove the panel lower cover (1).
7. Disconnect the hour meter cable (3).

(When reassembling)

- Tighten the steering wheel mounting nut securely.

Tightening torque	Steering wheel mounting nut	20 to 40 N·m 2.1 to 4.0 kgf·m 15 to 29 lbf·ft
-------------------	-----------------------------	---

- | | |
|-----------------------|----------------------|
| (1) Panel Lower Cover | (3) Hour Meter Cable |
| (2) Shuttle Lever | |

9Y1210982CLS0009US0



Separating Clutch Housing

1. Support the transmission with a disassembling stand.
2. Hook the engine with a hoist.
3. Remove the docking bolts and nuts between the engine and the front case.

(When reassembling)

- Align the spline between the front wheel drive shaft and the coupling securely.
- Tighten the docking bolts between the engine and the front case securely.
- Apply liquid gasket (Three Bond 1206D or equivalent) to the joint face of the engine and the front case.

9Y1210982CLS0014US0

(2) Separating Clutch Assembly

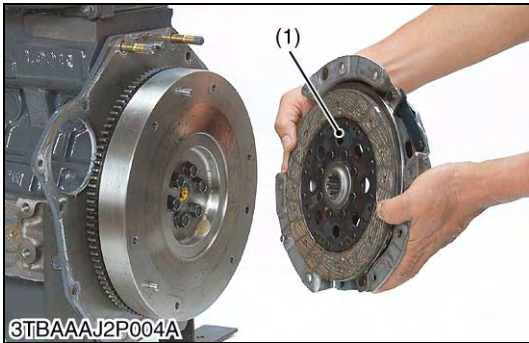

Separating the Clutch Assembly

1. Remove the clutch assembly from the flywheel.

(When reassembling)

- Direct the shorter end of the clutch disc boss toward the flywheel.
- Apply molybdenum disulphide (Three Bond 1901 or equivalent) to the splines of clutch disc boss.
- Install the pressure plate, noting the position of straight pins.

■ IMPORTANT

- **Align the center of clutch disc and flywheel by inserting the clutch center tool.**

■ NOTE

- **Do not allow grease and oil on the clutch disc facing.**

Tightening torque	Clutch mounting screw	23.5 to 27.5 N·m 2.4 to 2.8 kgf·m 17.4 to 20.2 lbf·ft
-------------------	-----------------------	---

(1) Clutch Disc

(2) Clutch Cover

9Y1210982CLS0015US0

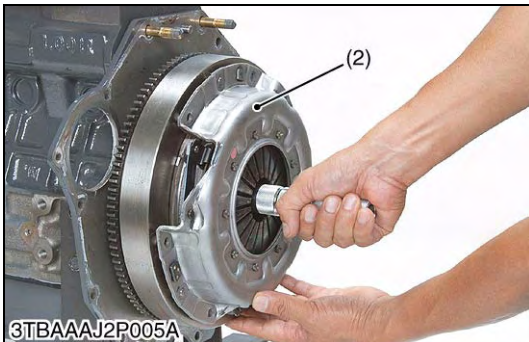

Clutch and Clutch Release Fork

1. Remove the external snap ring (2) at the end of clutch rod shaft (1) and remove the clutch release fork (5) and the release bearing (3) with release bearing holder (4).

(When reassembling)

- Set the clutch release fork and the release bearing with the release folk spring (6) in the correct direction.

- (1) Clutch Rod Shaft
- (2) External Snap Ring
- (3) Clutch Release Bearing

- (4) Release Bearing Holder
- (5) Clutch Release Folk
- (6) Release Folk Spring

9Y1210982CLS0016US0

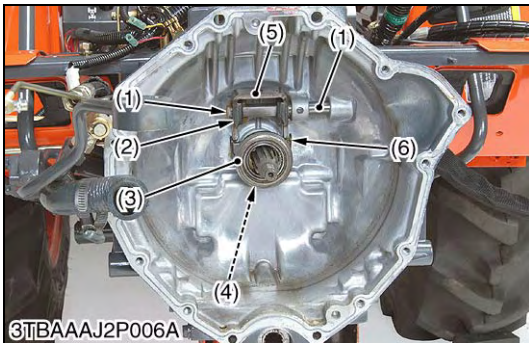

[3] SERVICING

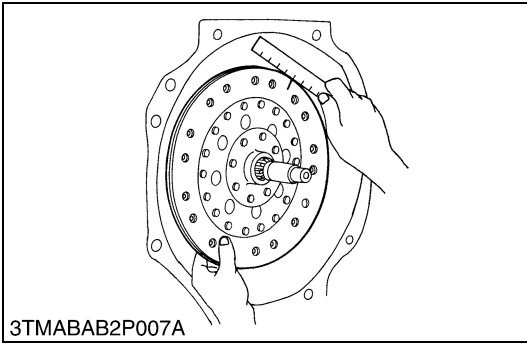

Backlash between Clutch Disc and Clutch Shaft

1. Mount the clutch disc onto the propeller shaft.
2. Hold the propeller shaft so that it does not rotate.
3. Slightly move the disc and measure the displacement around the disc edge.
4. If the measurement exceeds the allowable limit, replace the clutch disc.

Displacement around disc edge	Allowable limit	2.0 mm 0.079 in.
-------------------------------	-----------------	---------------------

9Y1210982CLS0017US0

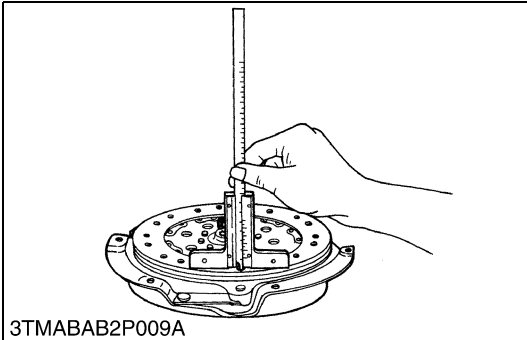

Clutch Disc Wear

1. Measure the depth from clutch disc surface to the top of the rivet at least 10 points with a depth gauge.
2. If the depth is less than the allowable limit, replace the disc.
3. If oil is sticking to clutch disc, or disc surface is carbonized, replace the disc.

Disc surface to rivet top (Depth)	Allowable limit	0.3 mm 0.012 in.
-----------------------------------	-----------------	---------------------

9Y1210982CLS0018US0

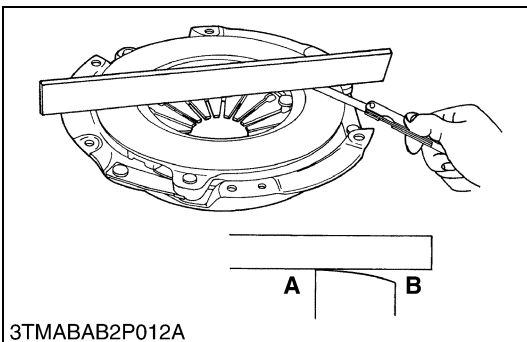

Pressure Plate Flatness

1. Place a straight edge on the pressure plate and measure clearance with a feeler gauge at several points.
2. If the clearance exceeds the allowable limit, replace it.
3. When the pressure plate is worn around its outside and its inside surface only is in contact with the straight edge, replace it even if the clearance is within the allowable limit.

Clearance between pressure plate and straight edge	Allowable limit	0.2 mm 0.008 in.
--	-----------------	---------------------

A: Inside

B: Outside

9Y1210982CLS0019US0

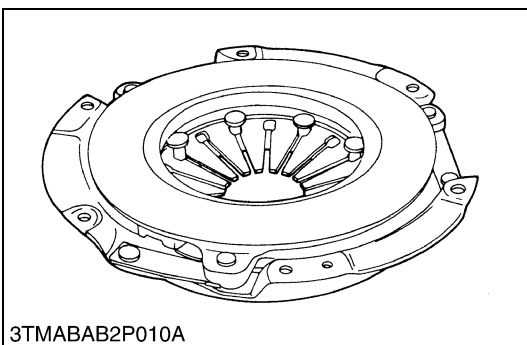

Checking Pressure Plate and Diaphragm

1. Check the pressure plate and if scratched on its surface, correct with sandpaper or replace.
2. Check the diaphragm for crack and scratches. If problems are found, replace it.

9Y1210982CLS0020US0

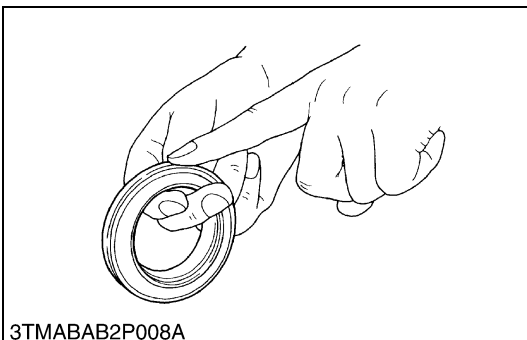

Checking Clutch Release Bearing

1. Check the clutch release bearing. If surface is worn excessively, or abnormal sounds occur, replace it.

9Y1210982CLS0021US0

3 TRANSMISSION

MECHANISM

CONTENTS

1. STRUCTURE.....	3-M1
[1] MANUAL TRANSMISSION (WITHOUT BI-SPEED TURN AND MID-PTO MODEL).....	3-M1
[2] MANUAL TRANSMISSION (WITHOUT BI-SPEED TURN AND WITH MID-PTO MODEL).....	3-M2
[3] MANUAL TRANSMISSION (WITH BI-SPEED TURN AND WITHOUT MID-PTO MODEL).....	3-M3
[4] MANUAL TRANSMISSION (WITH BI-SPEED TURN AND MID-PTO MODEL)	3-M4
[5] HST (WITH BI-SPEED TURN AND MID-PTO MODEL).....	3-M5
2. FRONT CASE.....	3-M6
[1] STRUCTURE (HST WITH BI-SPEED TURN MODEL)	3-M6
[2] BI-SPEED TURN LINKAGE	3-M7
(1) Linkage	3-M7
(2) Linkage: Bi-Speed Turn "Engaged"	3-M7
(3) Linkage: Bi-Speed Turn "Disengaged"	3-M8
[3] BI-SPEED TURN POWERTRAIN	3-M9
(1) HYDRAULIC CIRCUIT	3-M9
(2) Bi-Speed Turn "Engaged"	3-M10
(3) Bi-Speed Turn "Disengaged"	3-M10
3. MANUAL TRANSMISSION	3-M11
[1] STRUCTURE	3-M11
(1) Main Gear Shift Section.....	3-M11
(2) Shuttle Gear Shift Section	3-M12
4. HYDROSTATIC TRANSMISSION.....	3-M13
[1] STRUCTURE	3-M13
[2] PUMP AND MOTOR	3-M15
[3] OIL FLOW AND VALVES	3-M16
[4] CONTROL LINKAGE	3-M23
(1) ROPS Model.....	3-M23
(2) CABIN Model.....	3-M23
5. CRUISE CONTROL.....	3-M24
[1] CRUISE CONTROL LINKAGE [CABIN MODEL]	3-M24
(1) Cruise Control.....	3-M24
(2) Cruise Control Release	3-M25
[2] CRUISE CONTROL LINKAGE (ROPS MODEL)	3-M26
(1) Cruise Control.....	3-M26
(2) Cruise Control Release	3-M27
6. RANGE GEAR SHIFT SECTION	3-M28
7. FRONT WHEEL DRIVE SECTION.....	3-M29
8. PTO SYSTEM (HYDRAULIC PTO CLUTCH MODEL).....	3-M30
[1] STRUCTURE	3-M30
[2] REAR PTO SECTION	3-M31
[3] REAR PTO / MID-PTO SECTION	3-M32
[4] MID-PTO SECTION	3-M33
[5] INDEPENDENT PTO	3-M34
(1) Hydraulic Circuit	3-M34
(2) Independent PTO Control Valve.....	3-M35
(3) Independent PTO Clutch.....	3-M36
(4) Independent PTO Lever "Engaged"	3-M37
(5) Independent PTO Lever "Disengaged"	3-M38

9. PTO SYSTEM (MECHANICAL PTO CLUTCH MODEL)	3-M39
[1] STRUCTURE.....	3-M39
[2] REAR PTO SECTION	3-M40
[3] REAR PTO / MID-PTO SECTION	3-M41
[4] MID-PTO SECTION.....	3-M41
[5] ONE-WAY CLUTCH SYSTEM	3-M42
10. DIFFERENTIAL GEAR SYSTEM	3-M43
[1] DIFFERENTIAL FUNCTION.....	3-M43
[2] DIFFERENTIAL LOCK	3-M44

1. STRUCTURE

[1] MANUAL TRANSMISSION (WITHOUT BI-SPEED TURN AND MID-PTO MODEL)

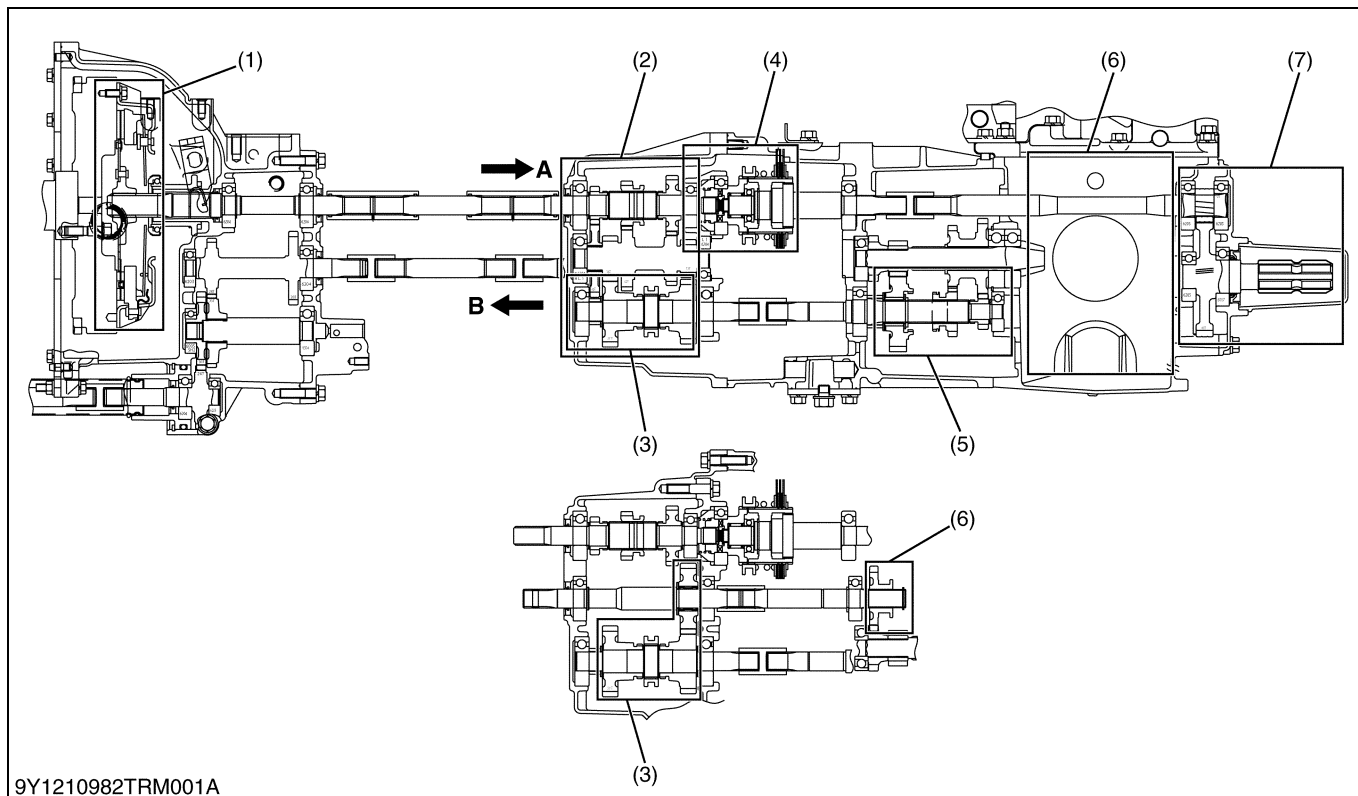

9Y1210982TRM001A

- | | | | |
|-----------------------------|-----------------------------------|------------------------------------|---------------------------|
| (1) Main Clutch Section | (4) Mechanical PTO Clutch Section | (7) Rear PTO Gear Section | A: From Front Case |
| (2) Main Gear Shift Section | (5) Range Gear Shift Section | (8) Front Wheel Drive Gear Section | B: To Front Axle |
| (3) Shuttle Shift Section | (6) Differential Gear Section | | |

9Y1210982TRM0001US0

[2] MANUAL TRANSMISSION (WITHOUT BI-SPEED TURN AND WITH MID-PTO MODEL)

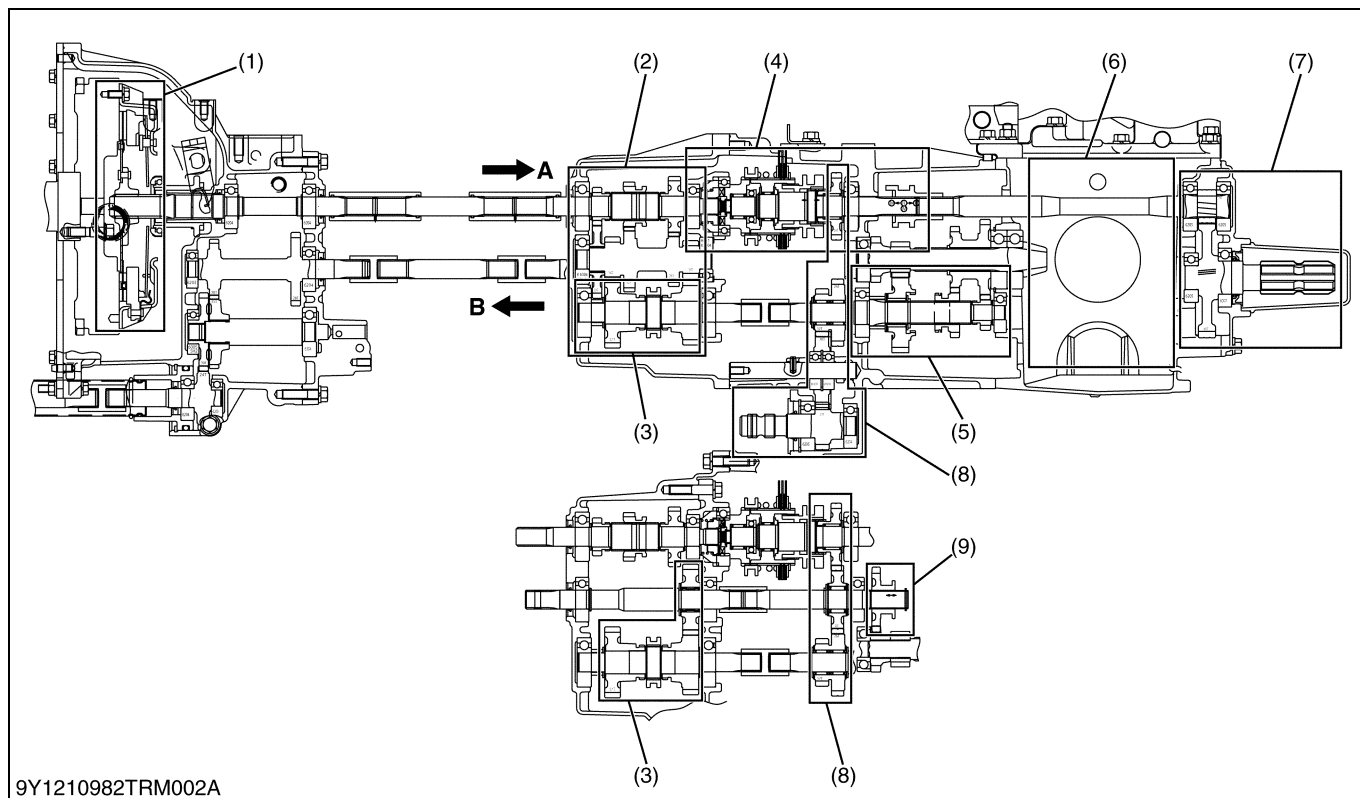

9Y1210982TRM002A

- | | | |
|-----------------------------|-----------------------------------|------------------------------------|
| (1) Main Clutch Section | (4) Mechanical PTO Clutch Section | (7) Rear PTO Gear Section |
| (2) Main Gear Shift Section | (5) Range Gear Shift Section | (8) Mid-PTO Gear Section |
| (3) Shuttle Shift Section | (6) Differential Gear Section | (9) Front Wheel Drive Gear Section |

A: From Front Case
B: To Front Axle

9Y1210982TRM0002US0

[3] MANUAL TRANSMISSION (WITH BI-SPEED TURN AND WITHOUT MID-PTO MODEL)

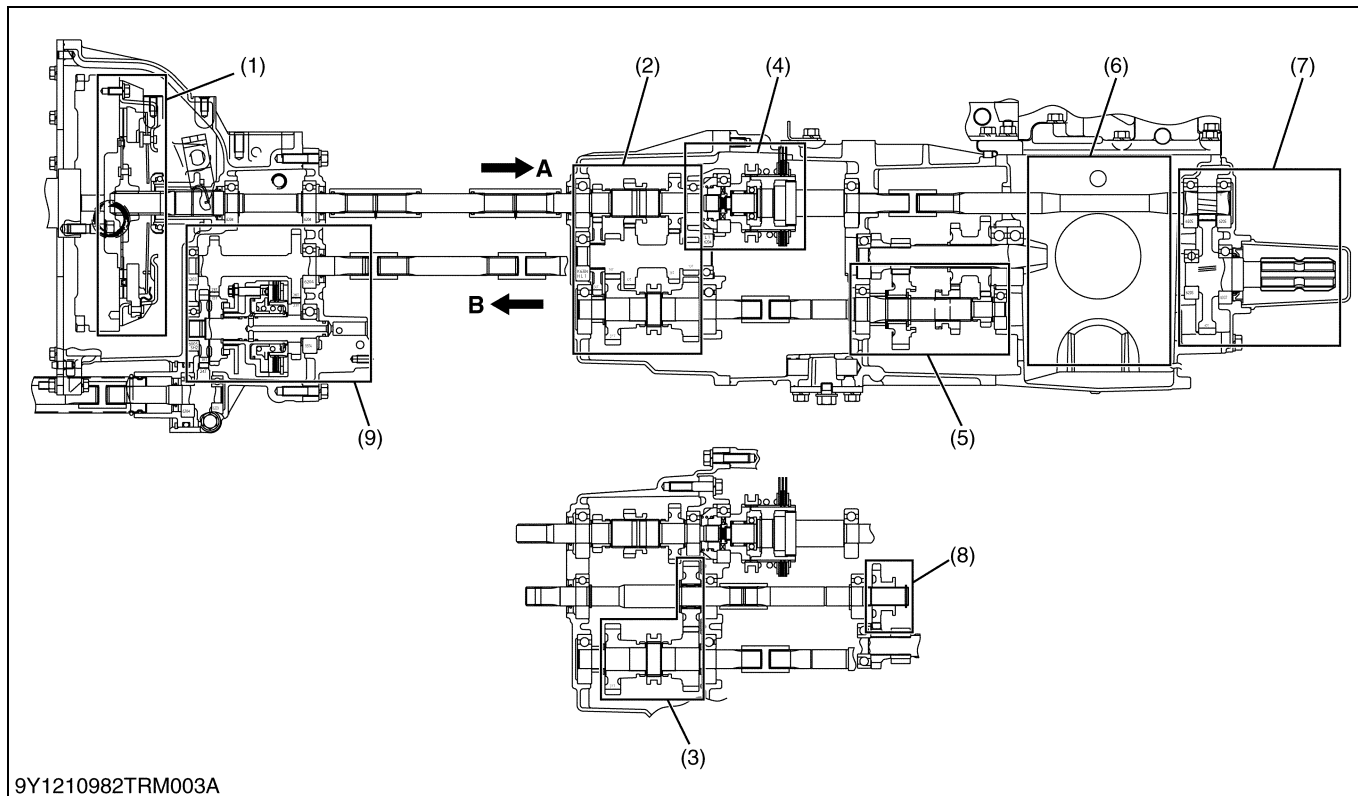

9Y1210982TRM003A

- | | | | |
|-----------------------------|-----------------------------------|------------------------------------|---|
| (1) Main Clutch Section | (4) Mechanical PTO Clutch Section | (7) Rear PTO Gear Section | A: From Front Case |
| (2) Main Gear Shift Section | (5) Range Gear Shift Section | (8) Front Wheel Drive Gear Section | B: To Bi-Speed Turn Gear Section |
| (3) Shuttle Shift Section | (6) Differential Gear Section | (9) Bi-Speed Turn Gear Section | |

9Y1210982TRM003US0

[4] MANUAL TRANSMISSION (WITH BI-SPEED TURN AND MID-PTO MODEL)

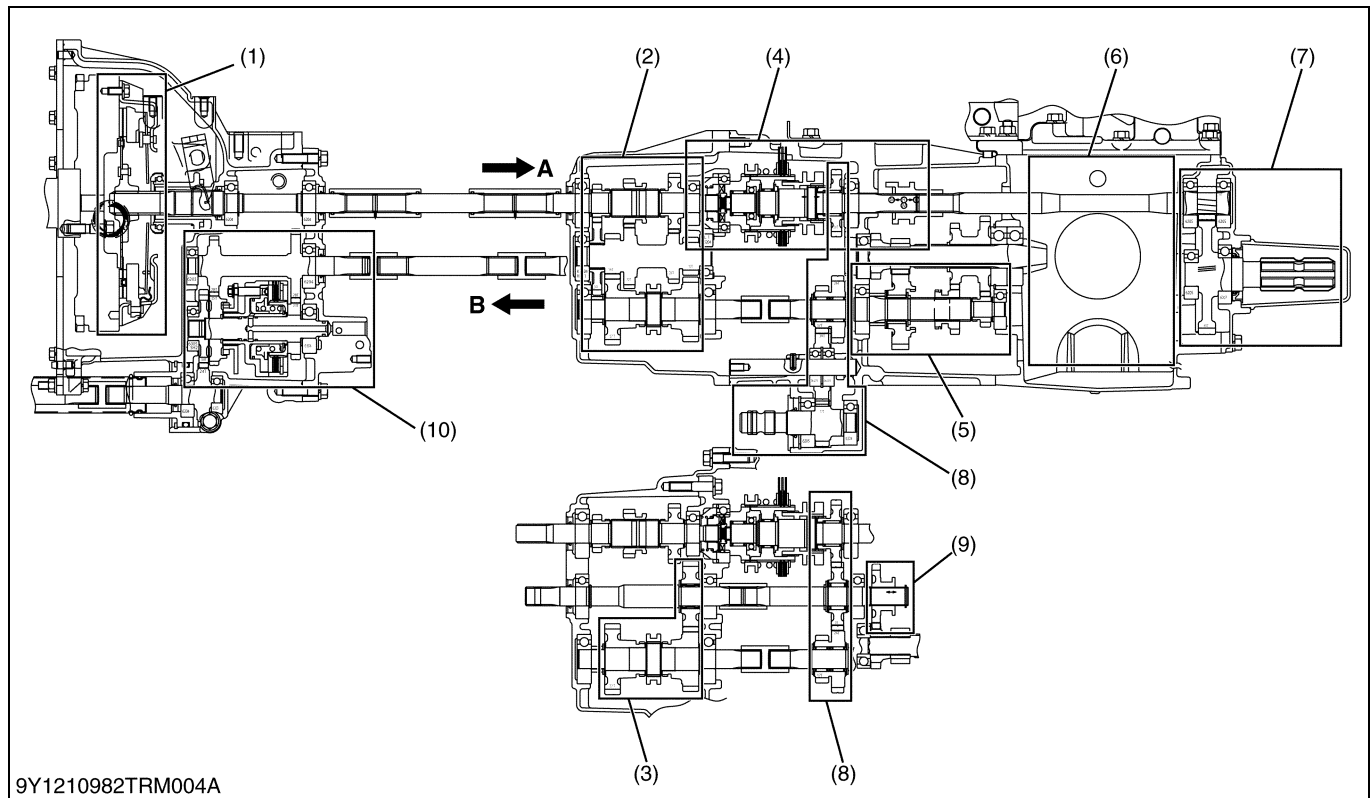

9Y1210982TRM004A

- | | | | |
|-----------------------------------|-------------------------------|------------------------------------|---|
| (1) Main Clutch Section | (5) Range Gear Shift Section | (9) Front Wheel Drive Gear Section | A: From Front Case |
| (2) Main Gear Shift Section | (6) Differential Gear Section | | B: To Bi-Speed Turn Gear Section |
| (3) Shuttle Shift Section | (7) Rear PTO Gear Section | (10) Bi-Speed Turn Gear Section | |
| (4) Mechanical PTO Clutch Section | (8) Mid-PTO Gear Section | | |

9Y1210982TRM0004US0

[5] HST (WITH BI-SPEED TURN AND MID-PTO MODEL)

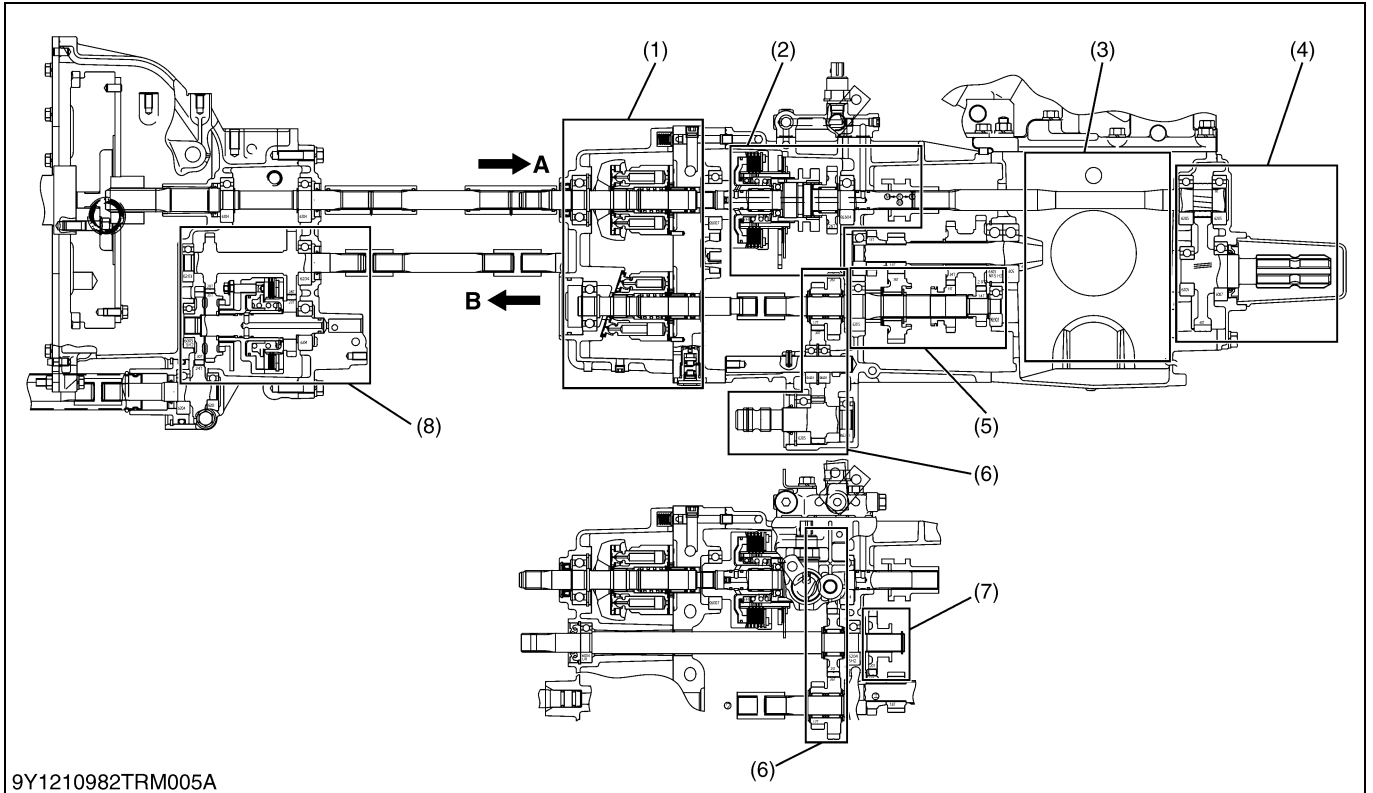

- (1) Hydrostatic Transmission (HST) Section
- (2) Hydrostatic PTO Section
- (3) Differential Gear Section

- (4) Rear PTO Gear Section
- (5) Range Gear Section
- (6) Mid-PTO Gear Section

- (7) Front Wheel Drive Gear Section
- (8) Bi-Speed Turn Gear Section

- A: From Front Case**
- B: To Bi-Speed Turn Gear Section**

9Y1210982TRM005US0

2. FRONT CASE

[1] STRUCTURE (HST WITH BI-SPEED TURN MODEL)

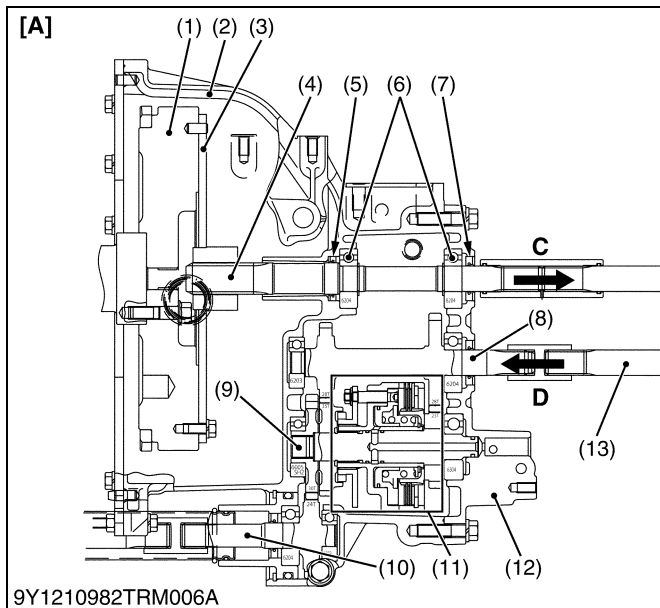

In this tractor, clutch disk is not installed.
 The steel plate (3) is installed on the clutch shaft (4).
 Power from the engine is transmitted through the steel plate (3) to the clutch shaft (4) and HST pump shaft.

- | | |
|---------------------------------------|--|
| (1) Flywheel | (13) Propeller Shaft |
| (2) Clutch Housing | (14) Main Clutch Section |
| (3) Steel Plate | (15) Propeller Shaft |
| (4) Clutch Shaft | (16) Propeller Shaft |
| (5) Oil Seal | |
| (6) Ball Bearing | [A] HST Model |
| (7) Oil Seal | [B] Manual Transmission Model (without Bi-Speed Turn) |
| (8) 28T-28T Front Wheel Drive Shaft 1 | C: To HST |
| (9) Front Wheel Drive Shaft 2 | D: From Front Wheel Drive Gear Section |
| (10) 24T Front Wheel Drive Shaft 3 | E: To Transmission Case |
| (11) Bi-Speed Turn Clutch | |
| (12) Front Mission Cover | |

9Y1210982TRM0006US0

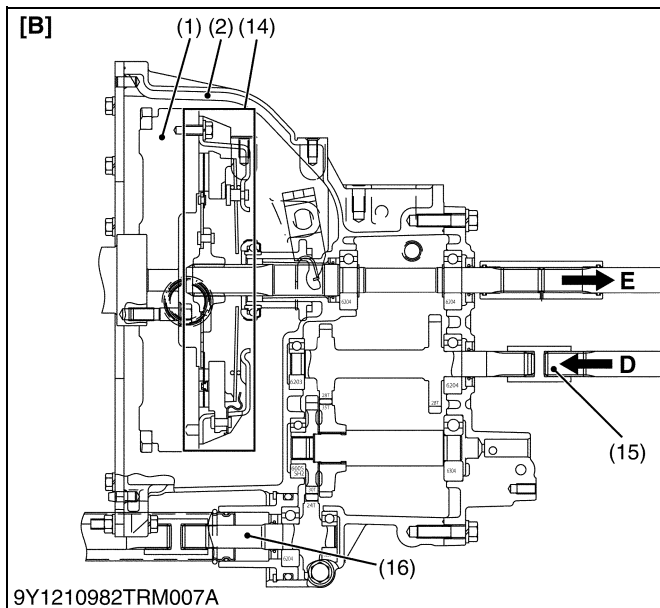

[2] BI-SPEED TURN LINKAGE

(1) Linkage

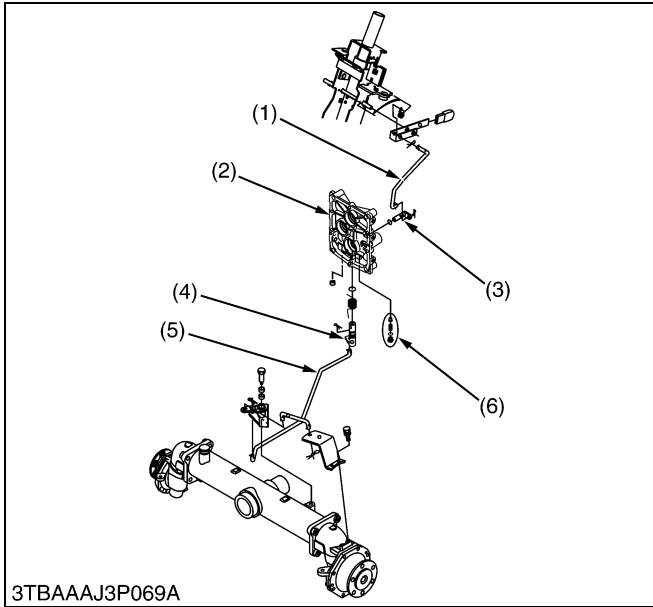

Bi-Speed Turn lever is connected to the Bi-Speed rod (1) and the Bi-Speed Turn ON/OFF shift shaft (3).

The left bevel gear case of the front axle is connected to the front Bi-Speed Turn shift shaft (4) with a Bi-Speed rod 2 (5).

- (1) Bi-Speed Rod 1
- (2) Front Mission Cover
- (3) Bi-Speed Turn ON/OFF Shift Shaft
- (4) Bi-Speed Turn Shift Shaft
- (5) Bi-Speed Rod 2
- (6) Regulating Valve (Only Manual Transmission Model)

A: Connected to the Left Bevel Gear Case

9Y1210982TRM0007US0

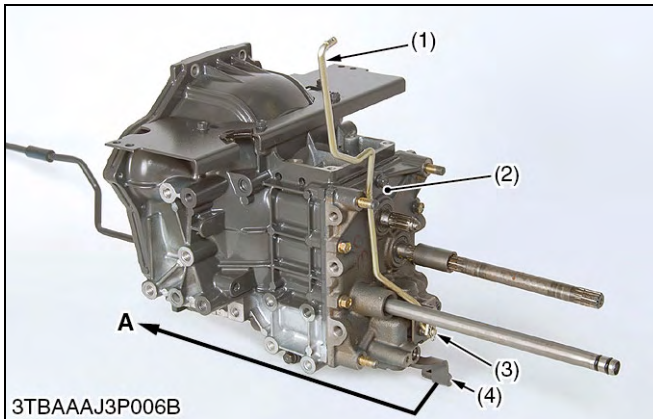

(2) Linkage: Bi-Speed Turn "Engaged"

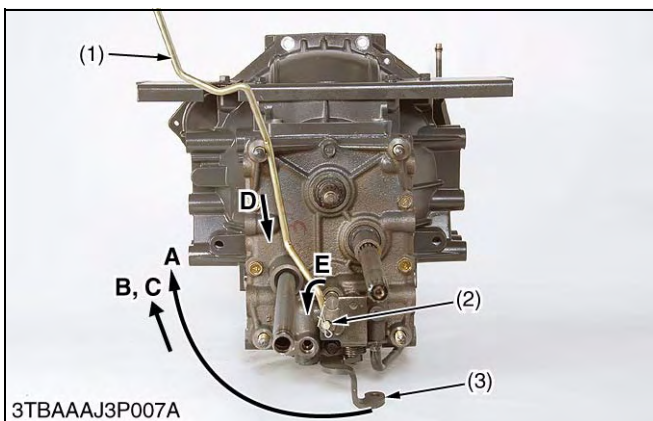

When the Bi-Speed Turn lever is shifted to **"ON"** position, the Bi-Speed rod 1 (1) is pushed down and the Bi-Speed Turn ON/OFF shift shaft (2) is rotated counterclockwise. It is kept **"ON"**.

When steering the steering wheel to **"Left"** or **"Right"**, the Bi-Speed rod 2 connected to the left bevel gear case is pulled. The Bi-Speed Turn shift shaft (3) is rotated.

At this time, hydraulic oil from the pump port enter to the Bi-Speed clutch shaft through both the Bi-Speed Turn shift shaft (3) and the Bi-Speed ON/OFF shift shaft (2).

The Bi-Speed Turn is engaged.

- (1) Bi-Speed Rod 1
- (2) Bi-Speed Turn ON/OFF Shift Shaft
- (3) Bi-Speed Turn Shift Shaft

A: Connected to the Left Bevel Gear Case

B: Left Turning

C: Right Turning

D: Bi-Speed Rod 1 "Engaged" Position

E: Bi-Speed Turn ON/OFF Shift Shaft "Engaged" Position

9Y1210982TRM0008US0

(3) Linkage: Bi-Speed Turn "Disengaged"

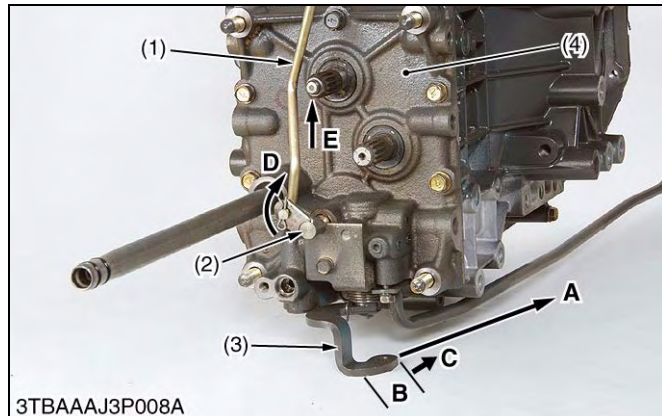

When the Bi-Speed Turn lever is shifted to **"OFF"** position, the Bi-Speed rod 1 (1) is pushed up and the Bi-Speed Turn ON/OFF shift shaft (2) is rotated clockwise. It is kept **"OFF"**.

When steering the steering wheel to **"Straight"**, the Bi-Speed rod 2 connected to the left bevel gear case is not pulled. The Bi-Speed Turn shift shaft (3) is kept to **"OFF"** position.

At this time, hydraulic oil from the pump port does not enter to the Bi-Speed Turn ON/OFF shift shaft.

The Bi-Speed Turn is disengaged.

- | | |
|--------------------------------------|--|
| (1) Bi-Speed Rod 1 | A: Connected to the Left Bevel Gear Case |
| (2) Bi-Speed Turn ON/OFF Shift Shaft | B: "OFF" Position |
| (3) Bi-Speed Turn Shift Shaft | C: "Engaged" Position |
| | D: Bi-Speed Turn ON/OFF Shift Shaft "Disengaged" Position |
| | E: Bi-Speed Rod 1 "Disengaged" Position |

9Y1210982TRM0009US0

[3] BI-SPEED TURN POWERTRAIN

(1) HYDRAULIC CIRCUIT

Manual Transmission Model

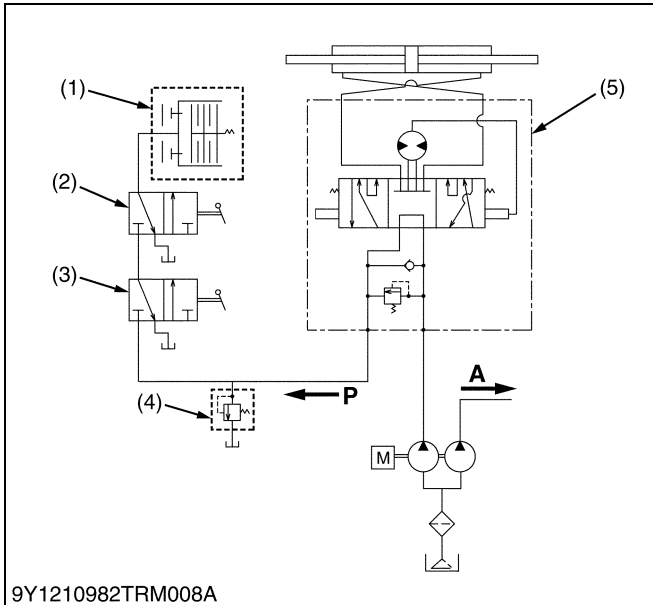

- (1) Bi-Speed Turn Clutch
- (2) Bi-Speed Turn Valve 2
- (3) Bi-Speed Turn Valve 1
- (4) Regulating Valve
- (5) Power Steering Controller

A: To 3-Points Hitch
P: From Pump Port

9Y1210982TRM0010US0

HST Model

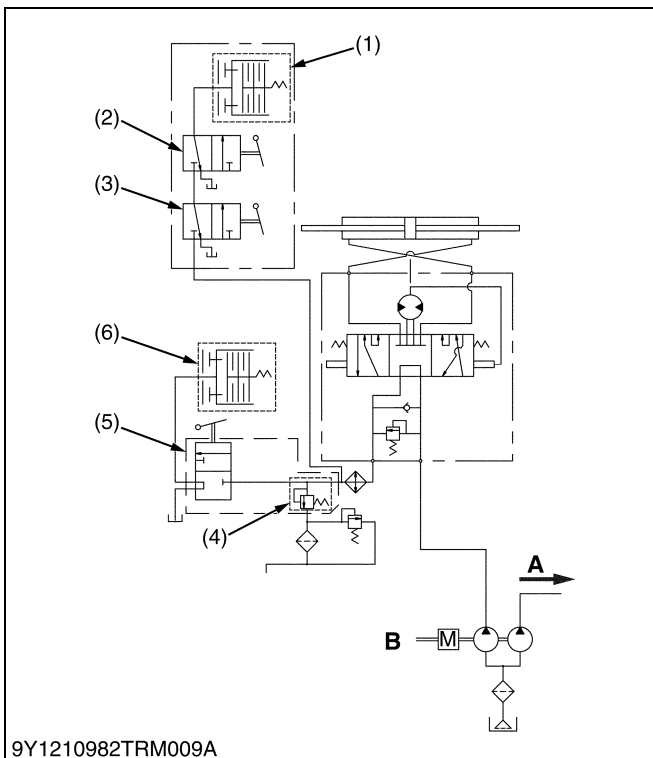

- (1) Bi-Speed Turn Clutch
- (2) Bi-Speed Turn Valve 2
- (3) Bi-Speed Turn Valve 1
- (4) Regulating Valve
- (5) Independent PTO Valve
- (6) Independent PTO Clutch

A: To 3-Points Hitch
B: HST

9Y1210982TRM0011US0

(2) Bi-Speed Turn "Engaged"

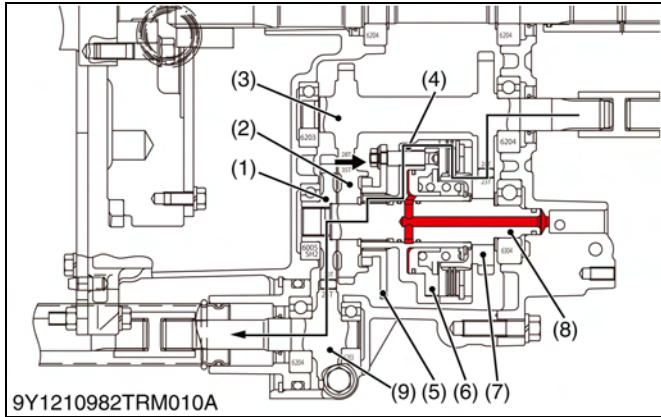

When a operator engage the Bi-Speed Turn lever to "ON" position and the front wheel steering angle is above approximately 0.714 rad (42 °), the Bi-Speed Turn engages.

At the time, since both the Bi-Speed Turn valve 1 and the Bi-Speed Turn valve 2 open, the pressured oil enter into the Bi-Speed Turn clutch shaft (8).

The pressured oil push the piston in the Bi-Speed Turn clutch, and the shifter (5) connected to the piston (6) slides into the Bi-Speed Turn clutch pack.

The shifter does not mesh to the 35T gear (2).

The power is transmitted from the front wheel drive shaft 1 (28T-28T) (3) through the 23T Bi-Speed Turn gear (7), the Bi-Speed Turn clutch pack, and the shifter (5) to the Bi-Speed Turn clutch shaft (8), and to the 30T gear (1) and to the front drive shaft 3 (24T) (9).

- | | |
|---------------------------------------|--|
| (1) 30T Gear | (6) Piston |
| (2) 35T Gear | (7) 23T Bi-Speed Turn Gear |
| (3) 28T-28T Front Wheel Drive Shaft 1 | (8) Bi-Speed Turn Clutch Shaft (Front Wheel Drive Shaft 2) |
| (4) Bi-Speed Turn Clutch Case | (9) 24T Front Wheel Drive Shaft 3 |
| (5) Shifter | |

9Y1210982TRM0012US0

(3) Bi-Speed Turn "Disengaged"

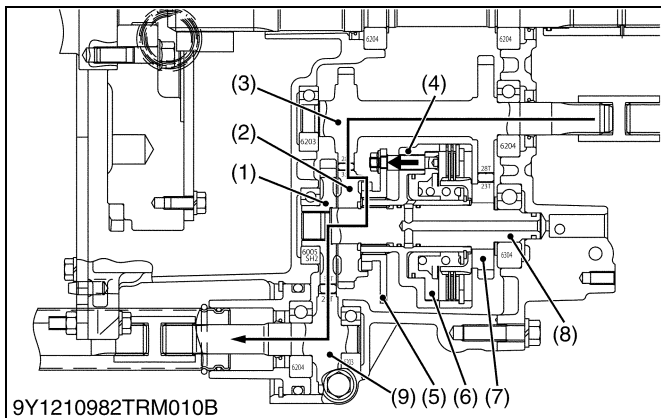

When the front wheel steering angle is below 0.714 rad (42 °), the Bi-Speed Turn is disengaged.

Since the pressurized oil is not delivered into the Bi-Speed Turn clutch pack, the shifter is pushed out to the 35T gear (2).

The shifter meshes to the 35T gear (2).

The power is transmitted as follows.

Front wheel drive shaft (28T-28T) (3) → 35T gear (2) → shifter (5) → Bi-Speed Turn clutch shaft (8) → 30T gear (1) → front drive shaft (24T) (9).

- | | |
|---------------------------------------|--|
| (1) 30T Gear | (6) Piston |
| (2) 35T Gear | (7) 23T Bi-Speed Turn Gear |
| (3) 28T-28T Front Wheel Drive Shaft 1 | (8) Bi-Speed Turn Clutch Shaft (Front Wheel Drive Shaft 2) |
| (4) Bi-Speed Turn Clutch Case | (9) 24T Front Wheel Drive Shaft 3 |
| (5) Shifter | |

9Y1210982TRM0013US0

3. MANUAL TRANSMISSION

[1] STRUCTURE

(1) Main Gear Shift Section

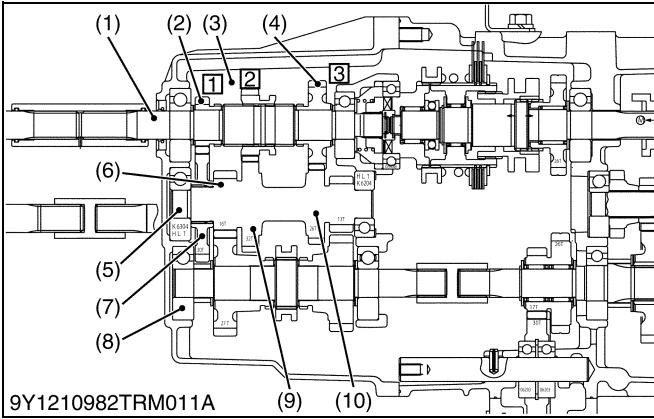

Main shift section consists of three speeds.

■ **1st Speed Gear**

The 23T F2 gear (shifter) (3) slides to the engine side.

The 23T F2 gear (shifter) (3) meshes to the 13T F1 gear (2).

The power is transmitted as follows.

First shift shaft (1) → 23T F2 gear (shifter) (3) → 13T F1 gear (2) → 30T F1 gear (7) → 16T-32T-26T-13T shaft (5).

■ **2nd Speed Gear**

The 23T F2 gear (shifter) (3) meshes to the 32T gear (9) of the 16T-32T-26T-13T shaft (5).

The power is transmitted as follows.

First shift shaft (1) → 23T F2 gear (shifter) (3) → 32T gear (9) / 16T-32T-26T-13T shaft (5).

■ **3rd Speed Gear**

The 23T F2 gear (shifter) (3) slides to the mechanical PTO clutch side.

The 23T F2 gear (shifter) (3) meshes to the 29T F3 gear (4).

The power is transmitted as follows.

First shift shaft (1) → 23T F2 gear (shifter) (3) → 29T F3 gear (4) → 26T gear (10) / 16T-32T-26T-13T shaft (5).

- | | |
|---------------------------|-------------------|
| (1) First Shift Shaft | (6) 16T Gear |
| (2) 13T F1 Gear | (7) 30T F1 Gear |
| (3) 23T F2 Gear (Shifter) | (8) Shuttle Shaft |
| (4) 29T F3 Gear | (9) 32T Gear |
| (5) 16T-32T-26T-13T Shaft | (10) 26T Gear |

9Y1210982TRM0014US0

(2) Shuttle Gear Shift Section

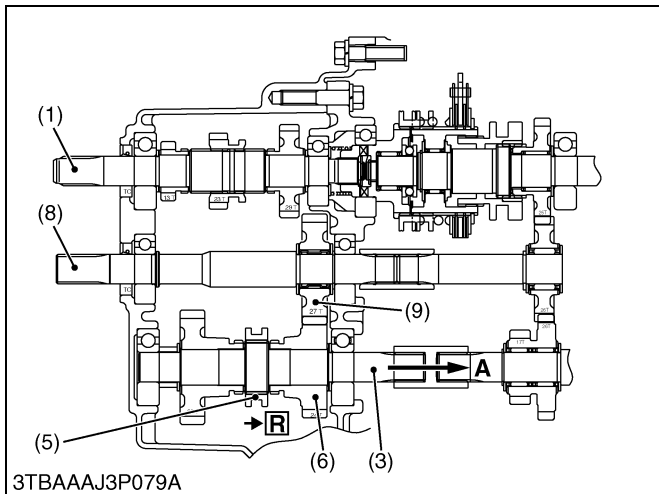
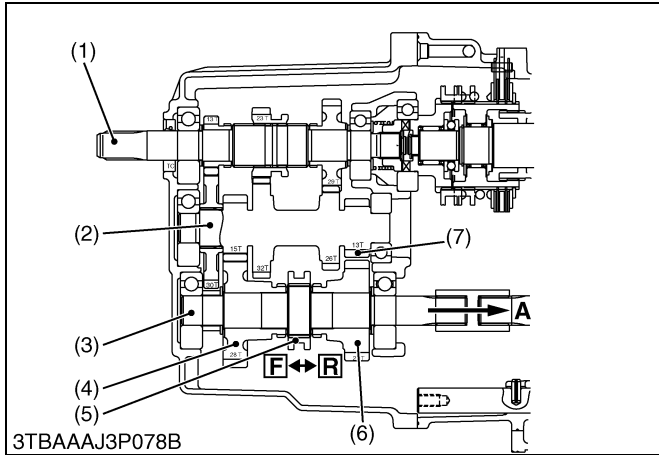

The power shifted in the main gear shift section is transmitted from the 16T-32T-26T-13T shaft (2) to the shuttle shaft (3).

The shuttle shift gears are the sliding mesh gears.

The reverse shaft is the front wheel drive shaft (8).

The 27T gear (9) on the front wheel drive gear (8) is a reverse gear.

■ Forward

When shifting the shuttle lever to "Forward", the shifter (5) slides to the 27T gear side.

The shifter (5) meshes to the 27T gear (4).

The power is transmitted as follows.

16T-32T-26T-13T shaft (2) / 15T gear (2) → 27T gear (4) → shifter (5) → shuttle shaft → Hi-Low range gear section.

■ Reverse

When shifting the shuttle lever to "Reverse", the shifter (5) slides to the 24T gear side.

The shifter is transmitted as follows.

16T-32T-26T-13T shaft (2) / 13T gear (7) → 27T gear (9) on the front wheel drive shaft (8) → 24T gear (6) → shifter (5) → shuttle shaft (3) → High-low range gear section.

- (1) First Shift Shaft
- (2) 16T-32T-26T-13T Shaft
- (3) Shuttle Shaft
- (4) 27T Gear
- (5) Shifter
- (6) 24T Gear
- (7) 13T Gear
- (8) Front Wheel Drive Shaft
- (9) 27T Gear

- F:** Forward
- R:** Reverse
- A:** To High-Low Range Gear Section

9Y1210982TRM0015US0

4. HYDROSTATIC TRANSMISSION

[1] STRUCTURE

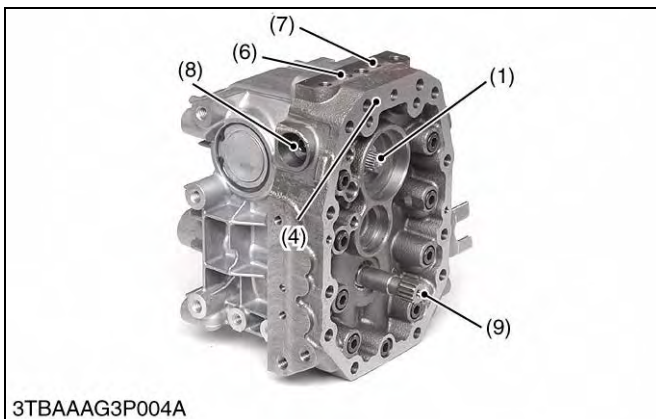
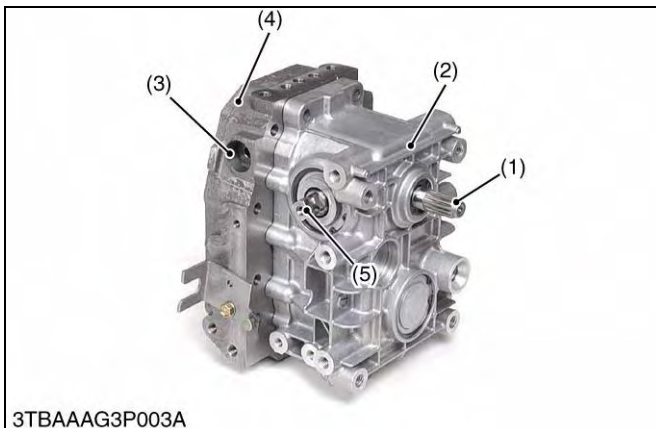

Hydrostatic transmission is composed of variable displacement piston pump, fixed displacement piston motor and valve system.

- (1) Input Shaft (Pump Shaft)
- (2) Housing
- (3) Check and High Pressure Relief Valve (Reverse)
- (4) Center Section
- (5) Trunnion Shaft
- (6) Check Port
- (7) Check Port
- (8) Check and High Pressure Relief Valve (Forward)
- (9) Output Shaft (Motor Shaft)

9Y1210982TRM0016US0

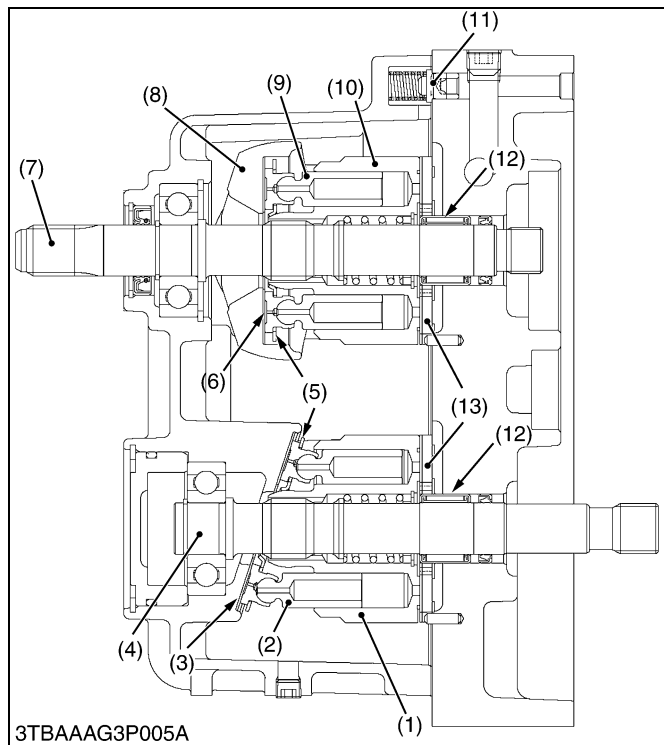

- (1) Cylinder Block (Motor)
- (2) Piston
- (3) Thrust Collar
- (4) Motor Shaft
- (5) Retainer Plate
- (6) Thrust Collar
- (7) Pump Shaft
- (8) Variable Swashplate
- (9) Piston
- (10) Cylinder Block (Pump)
- (11) Charge Relief Valve
- (12) Needle Bearing
- (13) Valve Plate
- (14) Check and High Pressure Relief Valve
- (15) Neutral Valve

9Y1210982TRM0017US0

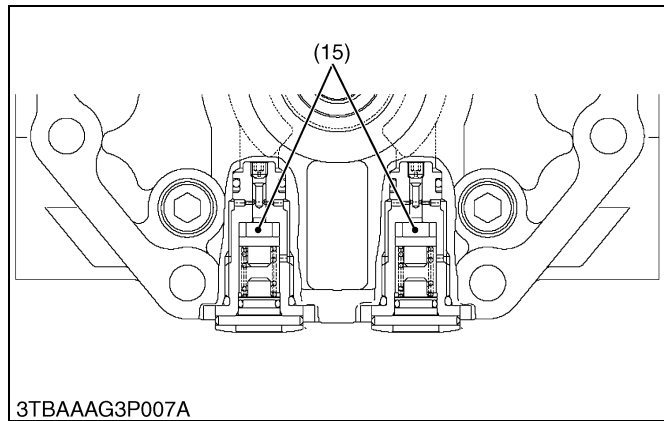
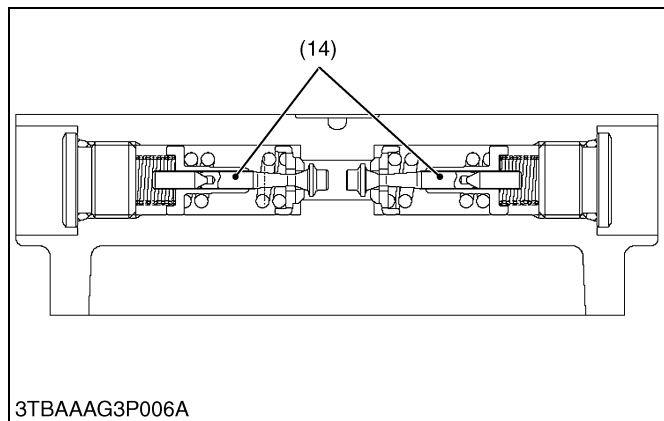

[2] PUMP AND MOTOR

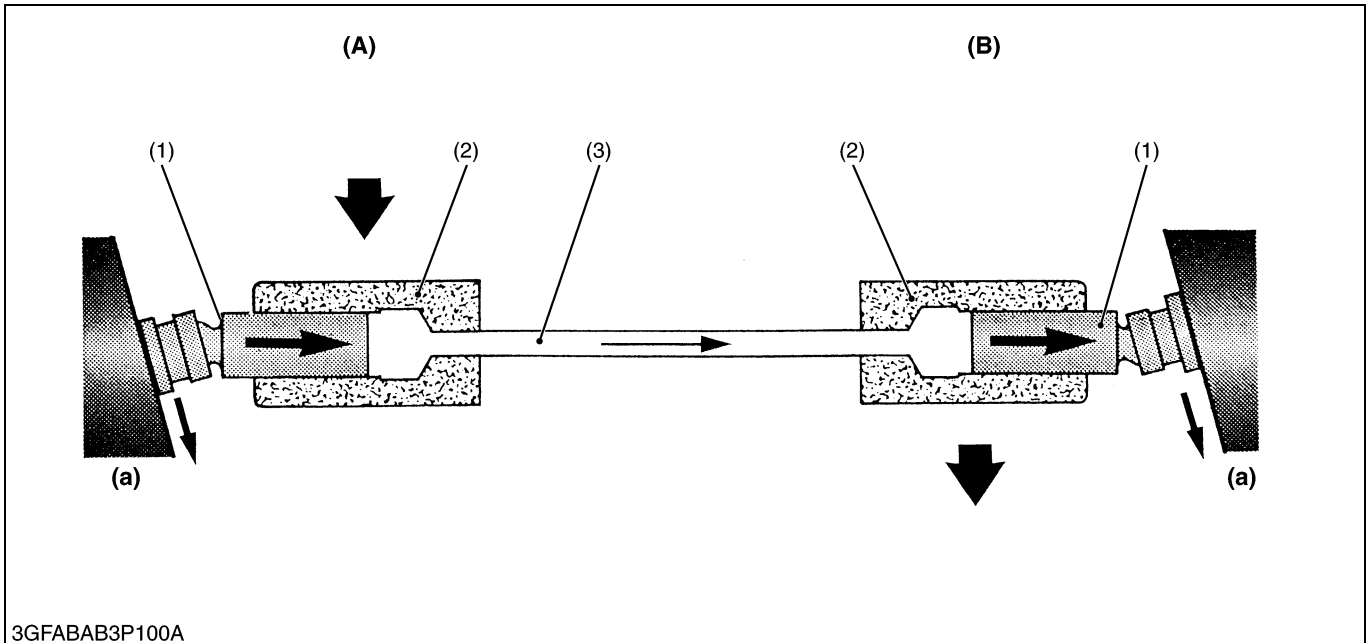

- (1) Piston
- (2) Cylinder
- (3) Oil
- (A) Pump
- (B) Motor
- (a) Swashplate

Pump and motor cylinder, each containing pistons, are connected by lines. Cylinders and lines are filled with oil piston ride against swashplates located in pump and motor.

In the pump, as the cylinder rotates, pistons move across the sloping face of swashplate and slide in or out of their cylinder bores. The oil forced out by the pump pistons, causes the motor pistons to slide out of their cylinder bores.

In the motor, sliding out of the cylinder and moving across the sloping face of swashplate, the pistons rotate the cylinder.

9Y1210982TRM0018US0

[3] OIL FLOW AND VALVES

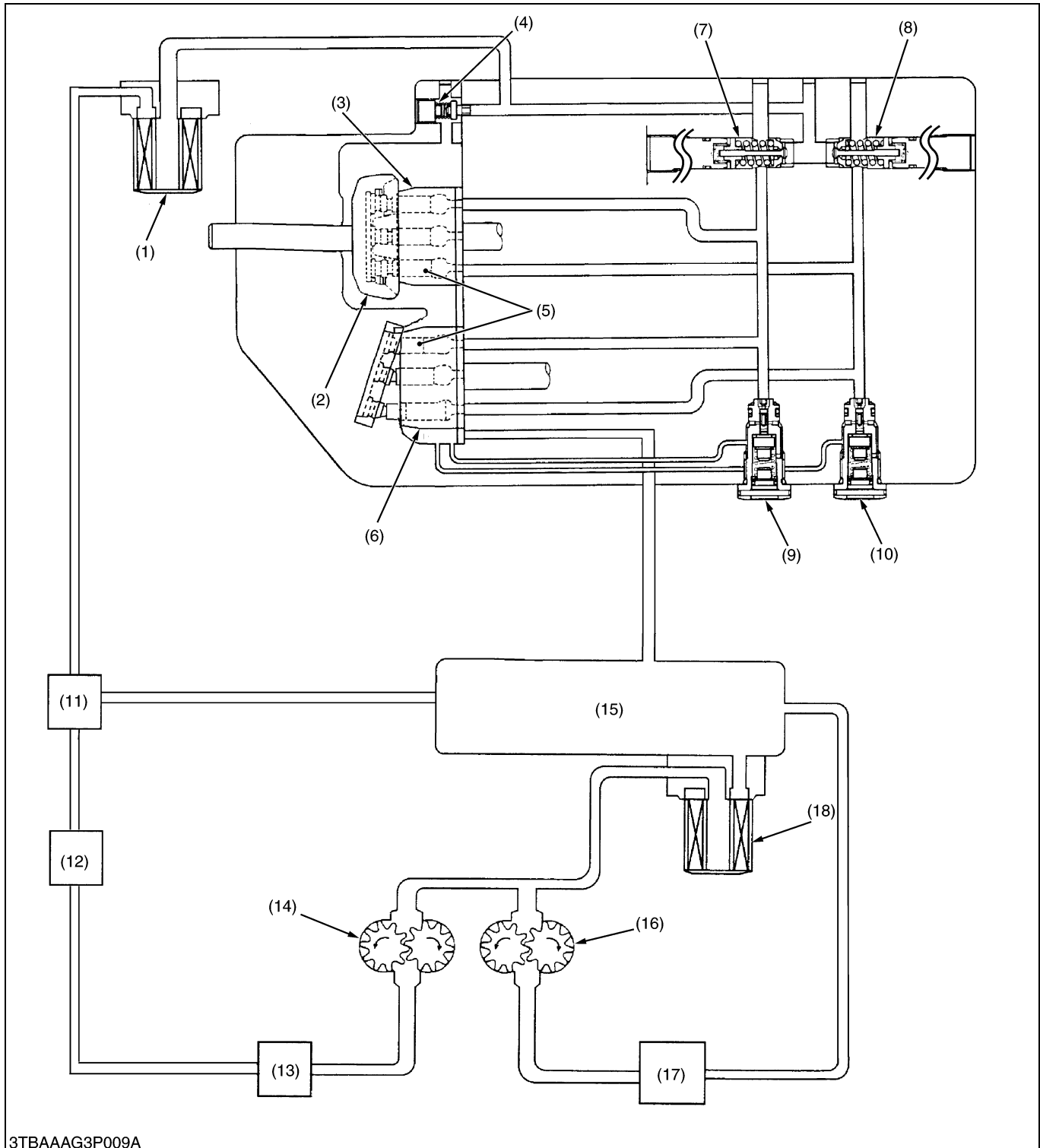

3TBAAAG3P009A

- | | | | |
|------------------------------------|--|--|---|
| (1) Oil Filter Cartridge (for HST) | (7) Check and High Pressure Relief Valve (for Forward) | (11) Independent PTO Control Valve | (15) Oil Tank |
| (2) Swashplate | (8) Check and High Pressure Relief Valve (for Reverse) | (12) Oil Cooler | (16) Hydraulic Pump (for 3-points Hitch) |
| (3) Cylinder Block (for Pump) | (9) Neutral Valve (for Forward) | (13) Power Steering | (17) Hydraulic Control Valve (for 3-points Hitch) |
| (4) Charge Relief Valve | (10) Neutral Valve (for Reverse) | (14) Hydraulic Pump (for Power Steering, Independent PTO, HST) | (18) Oil Filter Cartridge |
| (5) Piston | | | |
| (6) Cylinder Block (for Motor) | | | |

(To be continued)

(Continued)

The pump and the motor are joined in a closed hydraulic circuit. Most of oil circulates with in the main oil circuit. A little oil lubricates and oozes out from the clearance between the moving parts in the case. Then oil in the main oil circuit of the HST needs to be supplied a want.

So all of oil fed from hydraulic pump flow to hydraulic transmission for charging and cooling.

The charge oil aids smooth operation of pistons for pump and motor. The charge oil passed to charge relief valve port. The rest of oil passed through the charge relief valve into the HST housing. And overflow oil from HST housing return to the transmission case.

9Y1210982TRM0019US0

Neutral

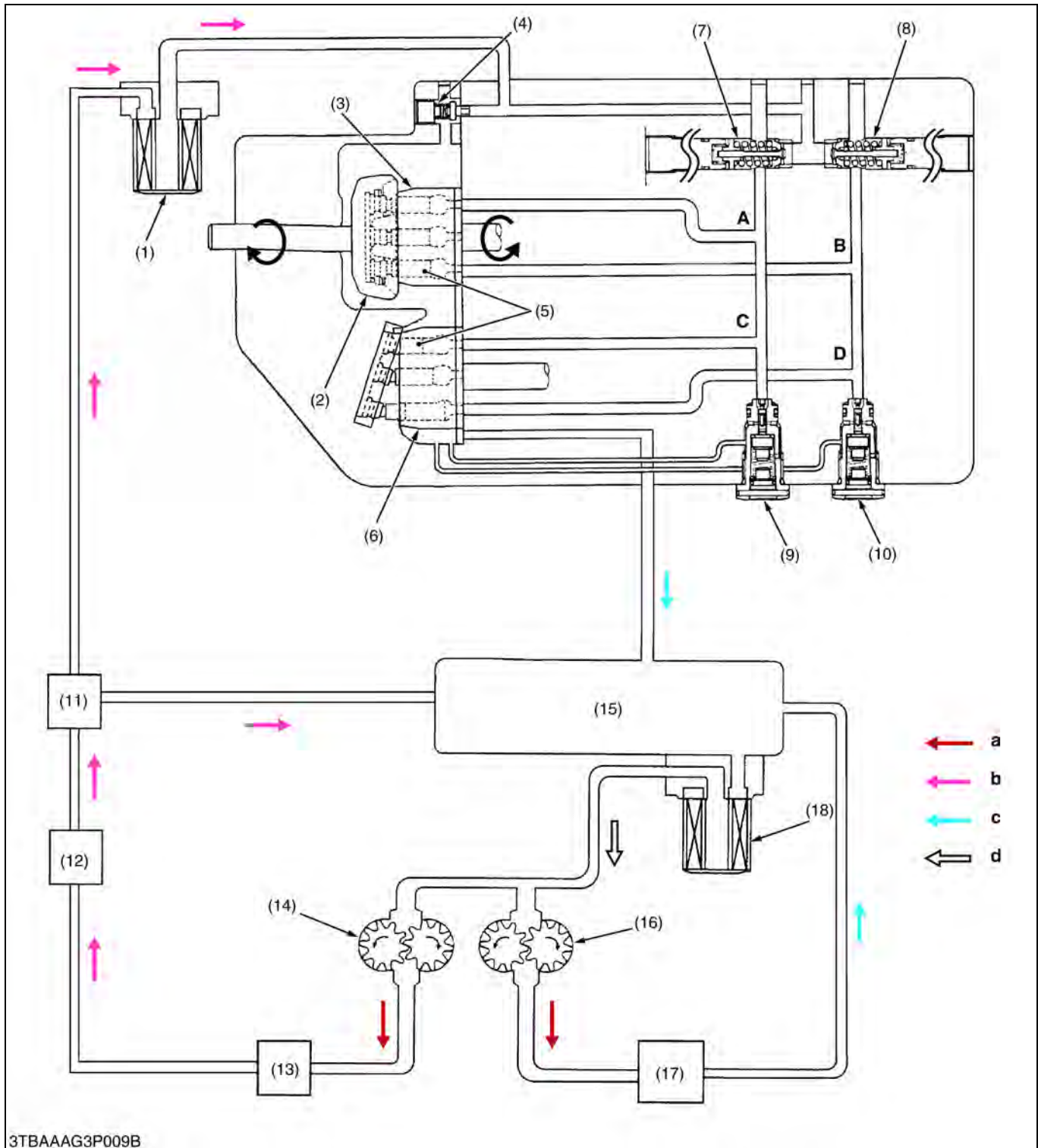

- (1) Oil Filter Cartridge (for HST)
- (2) Swashplate
- (3) Cylinder Block (for Pump)
- (4) Charge Relief Valve
- (5) Piston
- (6) Cylinder Block (for Motor)
- (7) Check and High Pressure Relief Valve (for Forward)

- (8) Check and High Pressure Relief Valve (for Reverse)
- (9) Neutral Valve (for Forward)
- (10) Neutral Valve (for Reverse)
- (11) Independent PTO Control Valve
- (12) Oil Cooler
- (13) Power Steering

- (14) Hydraulic Pump (for Power Steering, Independent PTO, HST)
- (15) Oil Tank
- (16) Hydraulic Pump (for 3-points Hitch)
- (17) Hydraulic Control Valve (for 3-points Hitch)
- (18) Oil Filter Cartridge

- A: Pump A Port**
- B: Pump B Port**
- C: Motor C Port**
- D: Motor D Port**
- a: High Pressure Oil**
- b: Low Pressure Oil**
- c: Free Oil**
- d: Suction Oil**

(To be continued)

(Continued)

When the speed control pedal (HST pedal) is in "**Neutral**", the variable swashplate is right-angles to the pump pistons. And the pump pistons only rotate with cylinder block (pump) without reciprocating.

Since the oil is not being pumped to the motor, the cylinder block (motor) is stationary. And the output shaft does not rotate.

9Y1210982TRM0020US0

(Continued)

When the speed control pedal (HST pedal) is stepped on and set to "**Forward**", the variable swashplate is tilted as shown in figure above.

As the pump cylinder block rotates with the input shaft, oil is forced out of pump port **A** at high pressure. As pressure oil from the pump cylinder block enters to motor port **C**, the pistons, which align with port **C**, are pushed against the swashplate and slide down the inclined surface.

Then the output shaft rotates with the motor cylinder block. This drives the machine forward and the angle of pump swashplate determines the output speed.

As the motor cylinder block continues to rotate, oil is forced out of motor port **D** at low pressure and returns to the pump port **B**.

9Y1210982TRM0021US0

Reverse

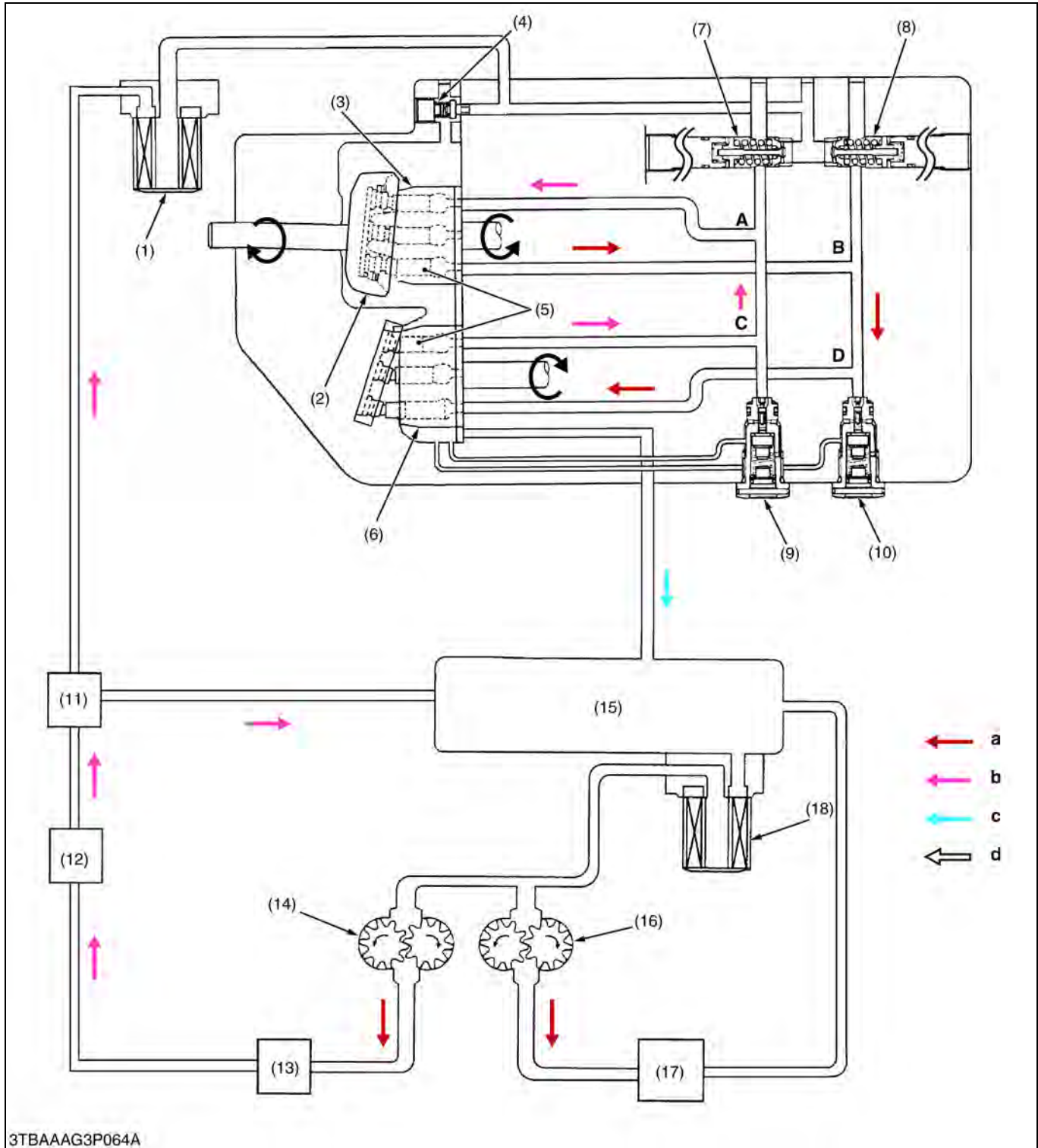

3TBAAAG3P064A

- | | | | |
|--|--|--|-----------------------------|
| (1) Oil Filter Cartridge (for HST) | (8) Check and High Pressure Relief Valve (for Reverse) | (14) Hydraulic Pump (for Power Steering, Independent PTO, HST) | A: Pump A Port |
| (2) Swashplate | (9) Neutral Valve (for Forward) | (15) Oil Tank | B: Pump B Port |
| (3) Cylinder Block (for Pump) | (10) Neutral Valve (for Reverse) | (16) Hydraulic Pump (for 3-points Hitch) | C: Motor C Port |
| (4) Charge Relief Valve | (11) Independent PTO Control Valve | (17) Hydraulic Control Valve (for 3-points Hitch) | D: Motor D Port |
| (5) Piston | (12) Oil Cooler | (18) Oil Filter Cartridge | a: High Pressure Oil |
| (6) Cylinder Block (for Motor) | (13) Power Steering | | b: Low Pressure Oil |
| (7) Check and High Pressure Relief Valve (for Forward) | | | c: Free Oil |
| | | | d: Suction Oil |

(To be continued)

(Continued)

When the speed control pedal (HST pedal) is stepped on and set to **"Reverse"**, the variable swashplate is tilted as shown in figure above.

As the pump cylinder block rotates with the input shaft, oil is forced out of pump port **B** at high pressure. As pressure oil from the pump cylinder block enters to motor port **D**, the pistons, which align with port **D**, are pushed against the swashplate and slide down the inclined surface.

Then the output shaft rotates with the motor cylinder block. This drives the machine reward and the angle of pump swashplate determines the output speed.

As the motor cylinder block continues to rotate, oil is forced out of motor port **C** at low pressure and retunes to the pump port **A**.

9Y1210982TRM0022US0

[4] CONTROL LINKAGE

(1) ROPS Model

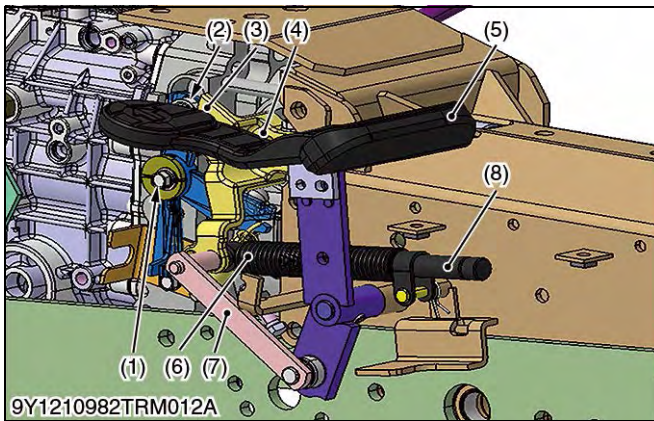

The HST pedal (5) and the trunnion shaft (4) of the variable swashplate are linked with the speed control rod (7) and the neutral holder (3). As the front footrest of the HST pedal (5) is depressed, the swashplate rotates and forward travelling speed increases. Depressing the rear footrest increases reverse travelling speed.

The roller (2) on the neutral holder arm (1) is held with spring seats and the detent of the neutral holder (3) so that the neutral holder (3) returns to neutral. When the pedal is released, the swashplate is returned to neutral with the neutral holder (3). The damper (8) connected to the HST pedal (5) restricts the movement of the linkage to prevent abrupt operation or reversing.

- | | |
|--------------------|-----------------------------|
| (1) Neutral Arm | (5) HST Pedal |
| (2) Roller | (6) Spring |
| (3) Neutral Holder | (7) Speed Control Rod (HST) |
| (4) Trunnion Shaft | (8) Damper |

9Y1210982TRM0023US0

(2) CABIN Model

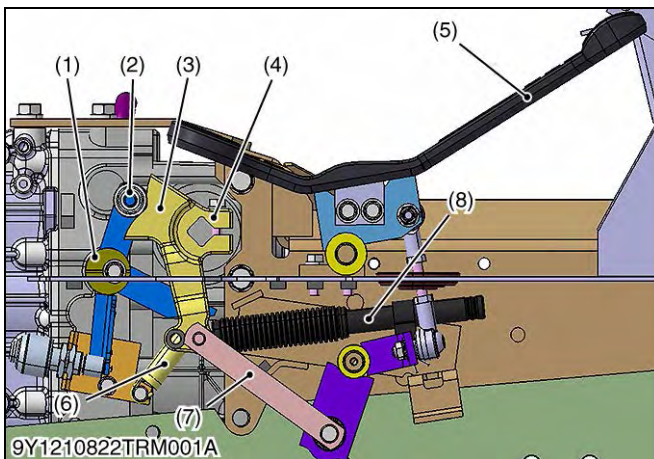

The HST pedal (5) and the trunnion shaft (4) of the variable swashplate are linked with the speed control rod (7) and the neutral holder (3). As the front footrest of the HST pedal (5) is depressed, the swashplate rotates and forward travelling speed increases. Depressing the rear footrest increases reverse travelling speed.

The roller (2) on the neutral holder arm (1) is held with spring seats and the detent of the neutral holder (3) so that the neutral holder (3) returns to neutral. When the pedal is released, the swashplate is returned to neutral with the neutral holder (3). The damper (8) connected to the HST pedal (5) restricts the movement of the linkage to prevent abrupt operation or reversing.

- | | |
|--------------------|-----------------------------|
| (1) Neutral Arm | (5) HST Pedal |
| (2) Roller | (6) Spring |
| (3) Neutral Holder | (7) Speed Control Rod (HST) |
| (4) Trunnion Shaft | (8) Damper |

9Y1210982TRM0046US0

5. CRUISE CONTROL

[1] CRUISE CONTROL LINKAGE [CABIN MODEL]

(1) Cruise Control

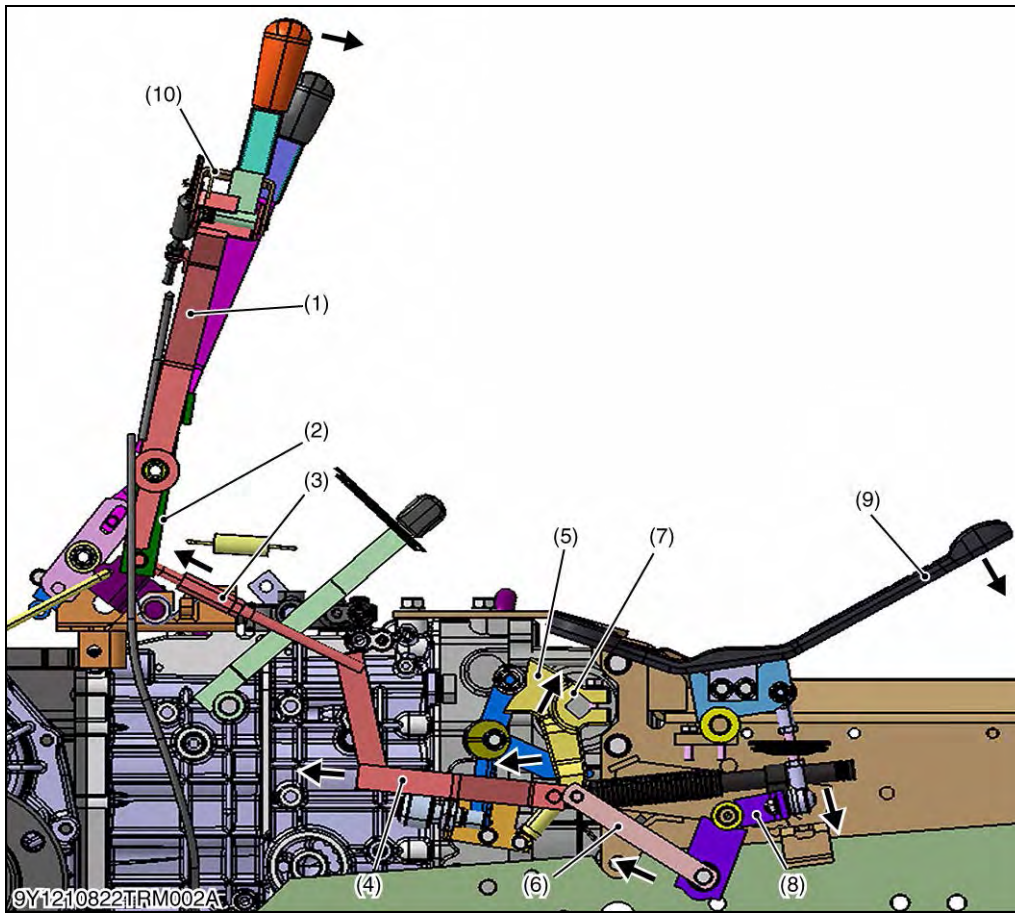

- (1) Cruise Control Lever
- (2) Cruise Link Lever
- (3) Cruise Rear Rod
- (4) Cruise Front Rod
- (5) Neutral Holder
- (6) HST Plate
- (7) Trunnion Shaft
- (8) HST Lever
- (9) HST Pedal
- (10) Release Lever

Cruise control system mainly consists of cruise control lever holding section and cruise control releasing section. When the cruise control lever (1) is set to the desired position, the bottom end of the cruise link lever (2) turns clockwise.

The control lever (1) pulls the cruise rear rod (3). The cruise rear rod (3) pulls the cruise front rod (4). The cruise front rod (4) pulls the neutral holder (5). The HST plate (6) is pulled by the cruise front rod (4).

Since the neutral holder (5) turns clockwise, the trunnion shaft (7) directly attached to the neutral holder (5) turns clockwise. On the other hand, since the HST plate (6) pulls the HST lever (8) and the HST pedal (9). The HST pedal (9) is turned to the front side.

On the other hand, since release lever (10) engage with tooth of lever guide RH, the cruise control lever (1) is held at the desired cruise position until the brake pedals will be depressed by an operator.

9Y1210982TRM0024US0

(2) Cruise Control Release

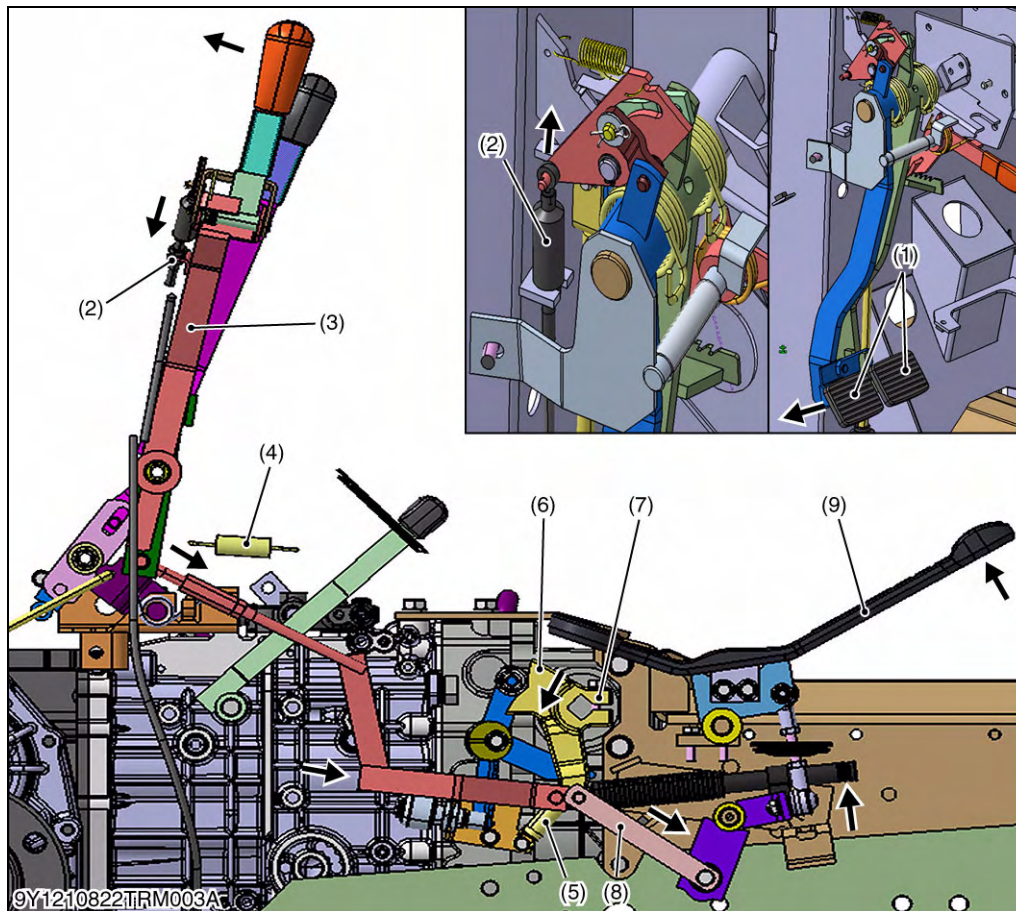

- (1) Brake Pedal
- (2) Cruise Cable
- (3) Cruise Control Lever
- (4) Return Spring
- (5) Return Spring
- (6) Neutral Holder
- (7) Trunnion Shaft
- (8) HST Plate
- (9) HST Pedal

Cruise control release is done by depressing the brake pedals (1).

When an operator depresses the brake pedal (1), the cruise cable (2) is pulled by the brake pedals (1).

At the time, the cruise control lever (3) is free. The cruise control lever (3) is returned to **"NEUTRAL"** position by the return spring (4).

On the other hand, the return spring (5) pulls the neutral holder (6). The neutral holder (6) and the trunnion shaft (7) turns counterclockwise. Since the neutral holder (6) is connected to the HST plate (8), the HST plate (8) is pushed to the front side. The HST plate (8) pushes the HST pedal (9) to return to **"NEUTRAL"** position.

9Y1210982TRM0025US0

[2] CRUISE CONTROL LINKAGE (ROPS MODEL)

(1) Cruise Control

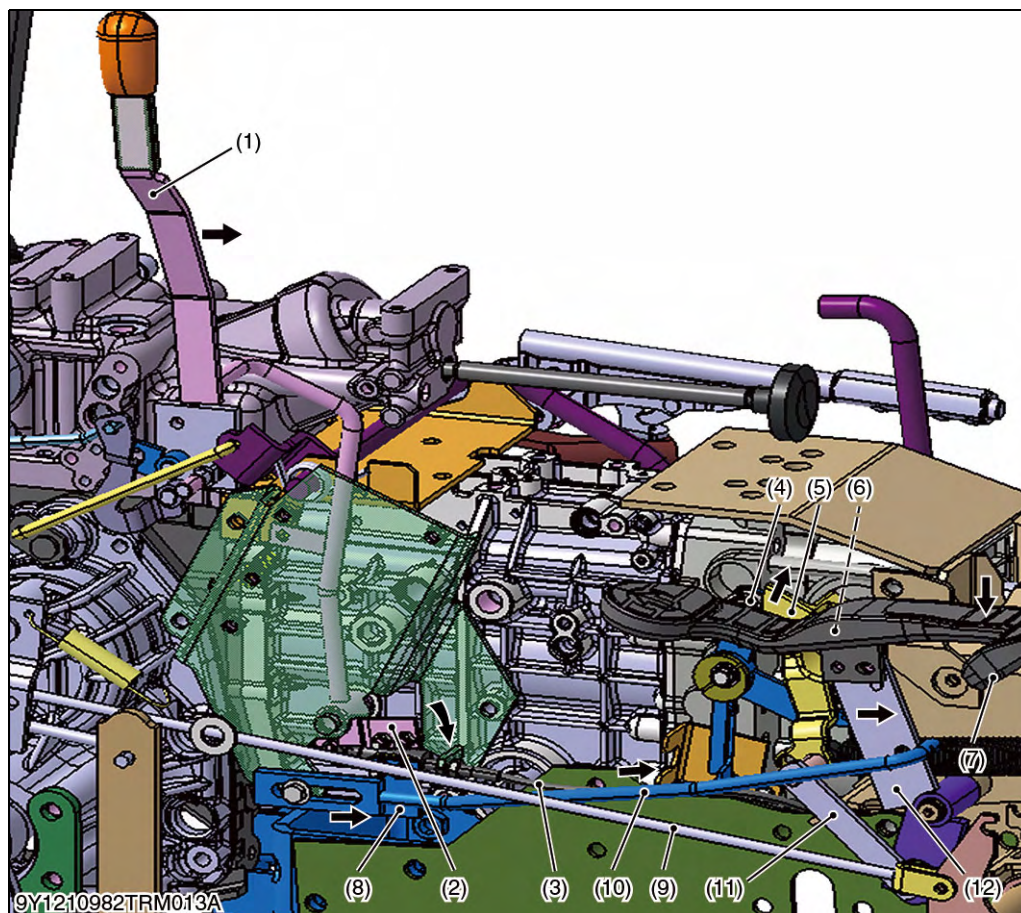

- (1) Cruise Control Lever
- (2) Cruise Lock 1
- (3) Release Wire
- (4) Roller
- (5) Neutral Holder
- (6) Trunnion Shaft
- (7) HST Pedal
- (8) Cruise Lock 2
- (9) Brake Rod
- (10) Cruise Rod
- (11) HST Plate
- (12) HST Lever

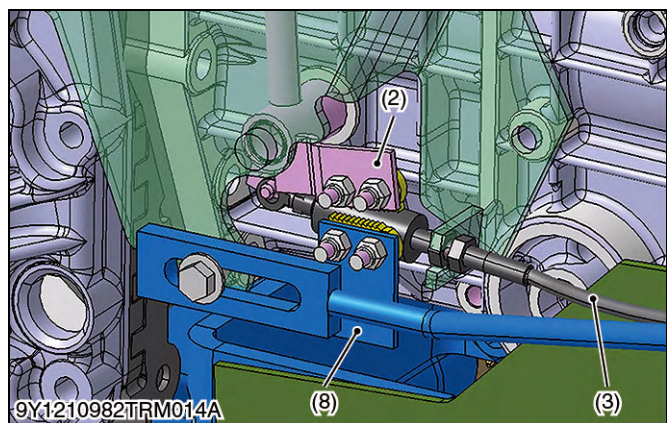

When depressing the HST pedal (7) to **"Forward"**, the HST lever (12), the cruise rod (10) and the cruise lock 2 (8) moves like the arrow shown in the pictures.

And when the cruise control lever (1) is set to the desired position, the cruise lock 1 (2) is locked to the cruise lock 2 (8) and travelling speed is held to the desired speed.

9Y1210982TRM0026US0

(2) Cruise Control Release

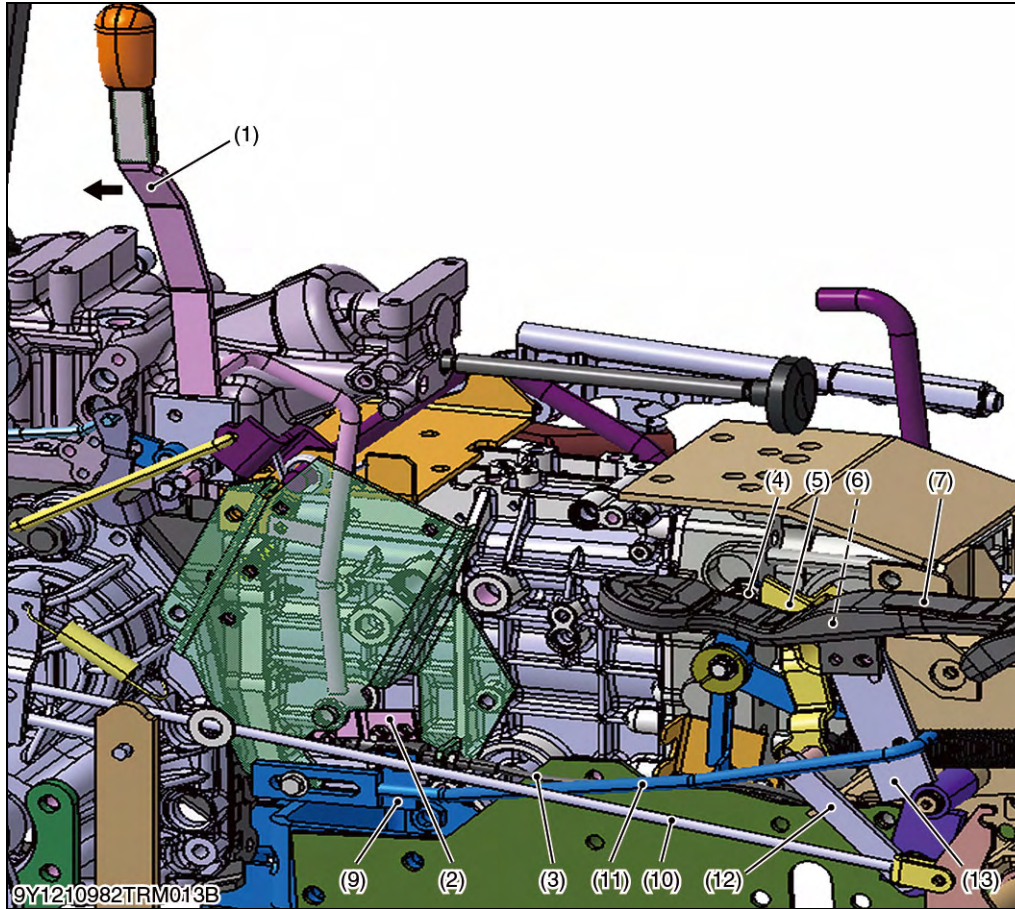

- (1) Cruise Control Lever
- (2) Cruise Lock 1
- (3) Release Wire
- (4) Roller
- (5) Neutral Holder
- (6) Trunnion Shaft
- (7) HST Pedal
- (8) Brake Pedal
- (9) Cruise Lock 2
- (10) Brake Rod
- (11) Cruise Rod
- (12) HST Plate
- (13) HST Lever

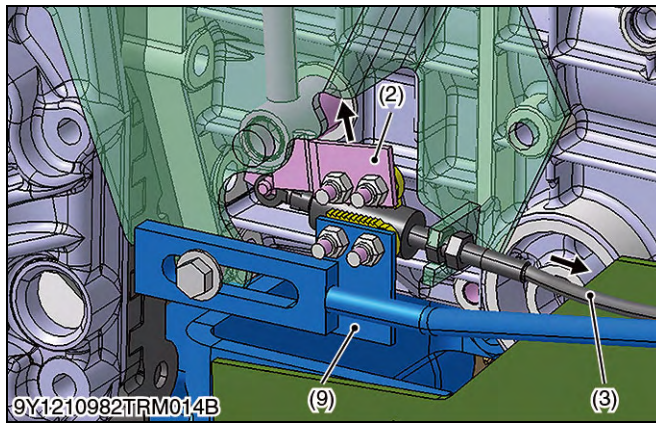

When depressing the brake pedals (8), the release wire (3), the cruise control lever (1) and the cruise lock 1 (2) moves like the arrow shown in the pictures.

And the cruise lock 1 (2) release from the cruise lock 2 (9).

Cruise lock is changed from **"ON"** to **"OFF"** position.

Since the cruise lock is kept **"OFF"**, the neutral holder turns counterclockwise, and the roller is returned to **"Neutral"** position. The HST pedal (7) also returns to **"Neutral"** position and the tractor stops.

9Y1210982TRM0027US0

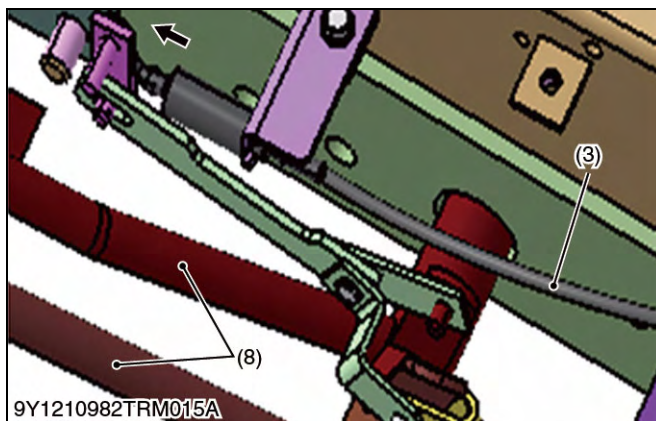

6. RANGE GEAR SHIFT SECTION

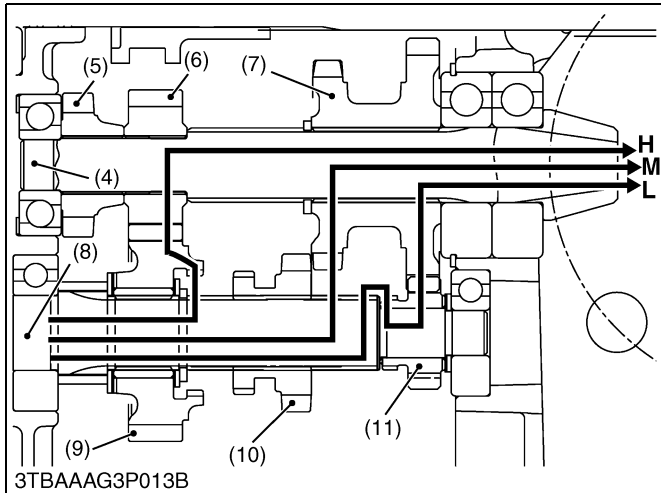
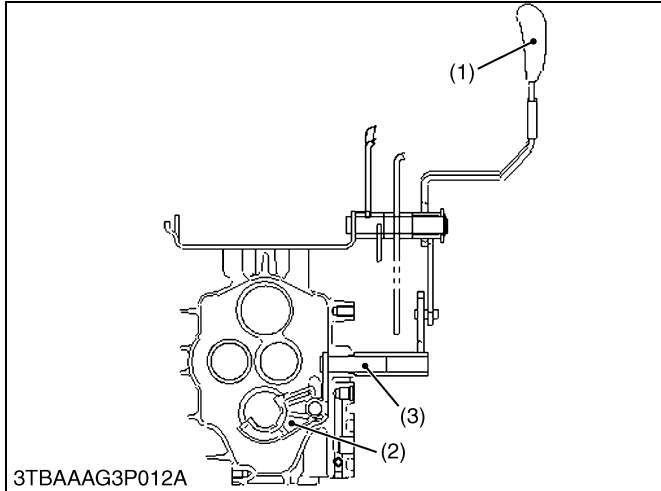

Range gear shift lever (1) is located at left side fender.

Range gear shift lever (1) can select three speed range, low speed, mid speed and high speed.

Range gear shift lever (1) and shifter gear (10) are linked with range shift arm (3) and range shift fork (2) etc..

Three range gear shifts are selected by shifting the shifter gear (10) on the sub shaft (8) to gear (6) and gear (7) on bevel pinion shaft (4).

■ **Low Speed Position**

Sub shaft (8) → shifter gear (10) → gear (11) → gear (7) → bevel pinion shaft (4).

■ **Middle Speed Position**

Sub shaft (8) → shifter gear (10) → gear (7) → bevel pinion shaft (4).

■ **High Speed Position**

Sub shaft (8) → shifter gear (10) → gear (9) → gear (6) → bevel pinion shaft (4).

Item	Number of gear teeth	Model
(5)	13	B2050, B2350, B2650
	14	B3150
(6)	12	Manual Transmission
	18	HST
(7)	25 - 31	Manual Transmission
	24 - 29	HST
(9)	31	Manual Transmission
	36	HST
(10)	18	Manual Transmission
	19	HST
(11)	12	Manual Transmission
	14	HST

- (1) Range Gear Shift Lever
 - (2) Range Shift Fork
 - (3) Range Shift Arm
 - (4) Bevel Pinion Shaft
 - (5) Gear (for Front Wheel Drive)
 - (6) Gear
 - (7) Gear
 - (8) Sub Shaft
 - (9) Gear
 - (10) Shifter Gear
 - (11) Gear
- L: "LOW" Range**
M: "MID" Range
N: "Neutral" Position
H: "HIGH" Range

9Y1210982TRM0028US0

7. FRONT WHEEL DRIVE SECTION

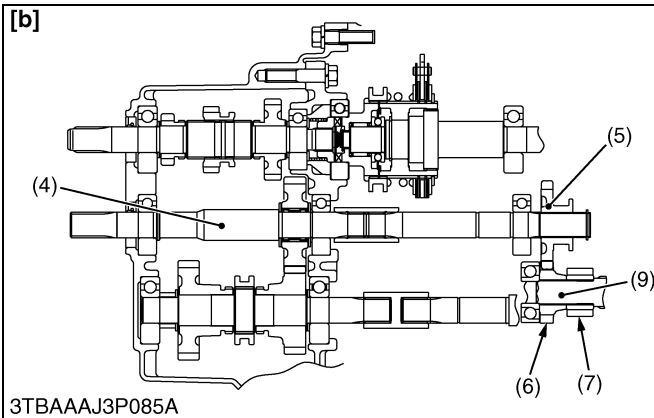
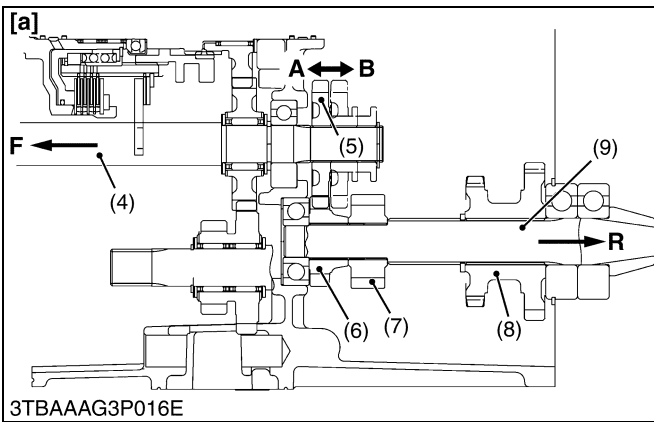
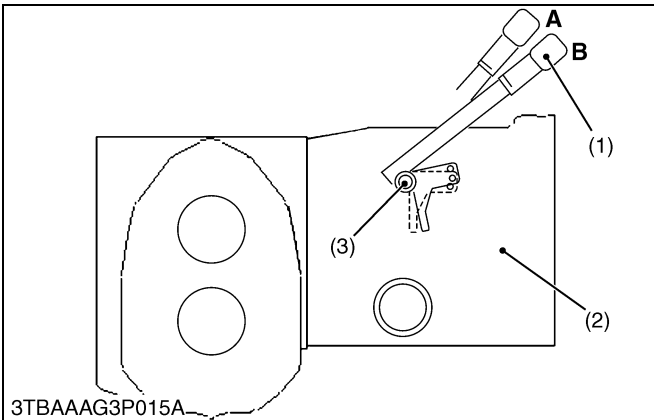
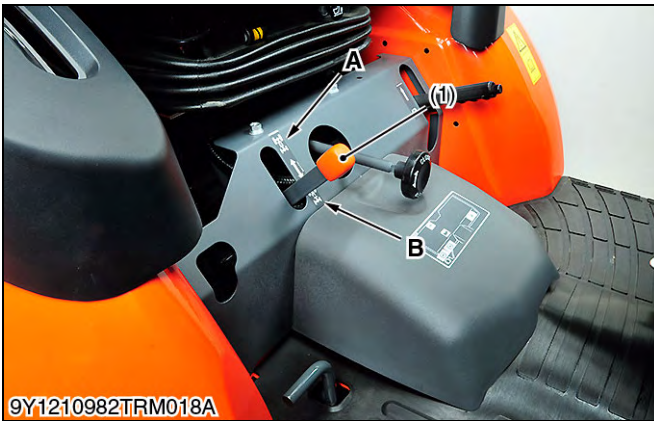

Front wheel drive lever (1) is located at the front floor cover.

Front wheel drive lever (1) and shifter (3) are linked. shifter gear (5) is located on the front wheel drive shaft (4).

2-wheel drive or 4-wheel drive is selected by changing the position of shifter gear (5) reverse or forward.

When the front wheel drive lever (1) is set to **"4 Wheel Drive Position"**, shifter gear (5) slides forward, meshes the gear (6) on the 6T bevel pinion shaft (9).

In this state, power from the 6T bevel pinion shaft (9) is transmitted through shifter gear (5) to the front wheel drive shaft (4) and the front wheels.

Item	Number of gear teeth	Model
(5)	19	B2050, B2350, B2650
	20	B3150
(6)	13	B2050, B2350, B2650
	14	B3150
(7)	12	Manual Transmission
	18	HST
(8)	25 - 31	Manual Transmission
	24 - 29	HST

- (1) Front Wheel Drive Lever
 - (2) Transmission Case
 - (3) Shifter
 - (4) Front Wheel Drive Shaft
 - (5) Shifter Gear
 - (6) Gear
 - (7) Gear
 - (8) Gear
 - (9) 6T Bevel Pinion Shaft
- A: 4 Wheel Drive Position**
 - B: 2 Wheel Drive Position**
 - F: Power to Front Wheels**
 - R: Power to Rear Wheels**
- [a] HST Model**
 - [b] Manual Transmission Model (without Mid-PTO)**

9Y1210982TRM0029US0

8. PTO SYSTEM (HYDRAULIC PTO CLUTCH MODEL)

[1] STRUCTURE

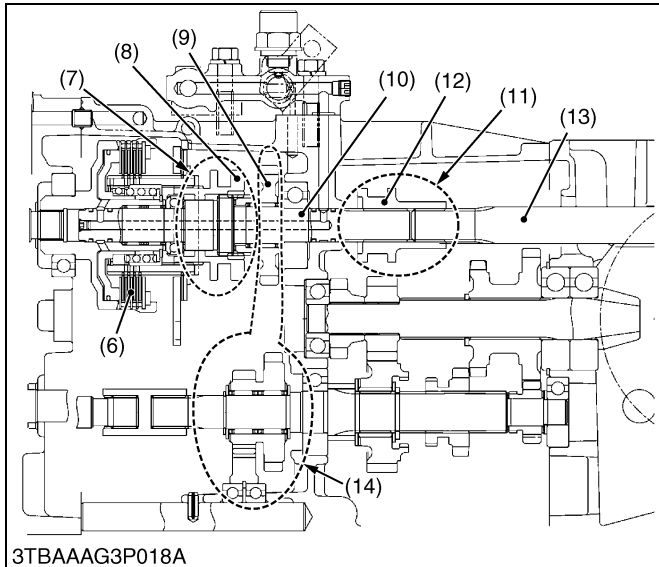
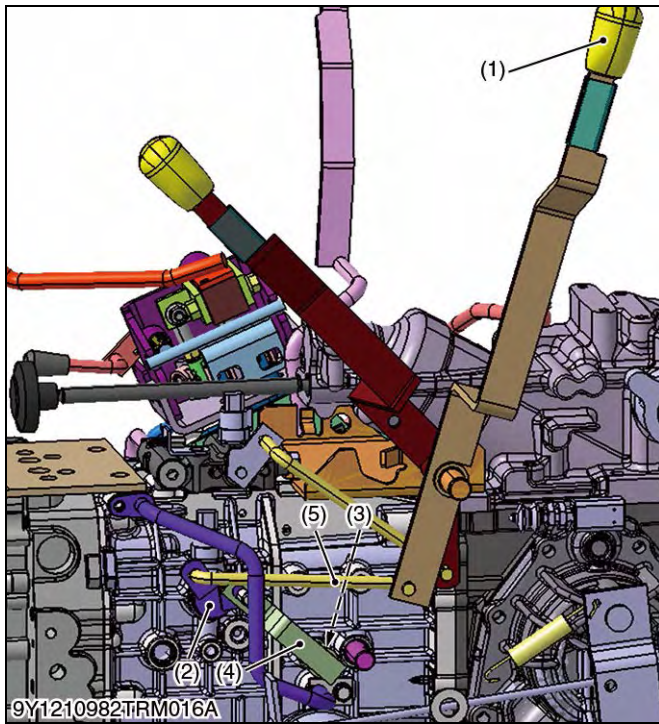
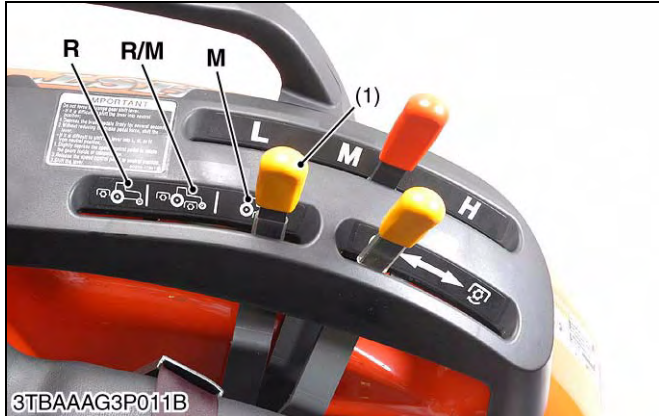

The PTO shift lever (1) is located at left side fender.

The PTO shift lever (1) and the PTO shift arm (2) are linked with the control rod (5). The PTO shift arm (2) and the rear PTO arm (3) linked with the rear PTO control plate.

The PTO shift arm (2) shifts the PTO shifter (8).

The rear PTO arm (3) shifts the rear PTO shifter (12).

PTO gear section consists of four sections.

The first section is independent PTO section.

The second section is PTO position selection section.

The third section is mid-PTO selection section.

The fourth section is rear PTO rotation prevention section.

In this section, when the PTO shift lever is set to "Mid-PTO" shifter slides to the front side and shifter meshes to the housing.

The rear PTO shift does not rotate at this "Mid-PTO" position.

- | | |
|---|---|
| (1) PTO Shift Lever | (12) Rear PTO Shifter |
| (2) PTO Shift Arm | (13) 9T Rear PTO Shaft |
| (3) Rear PTO Arm | (14) Mid PTO Selection Section |
| (4) Rear PTO Control Plate | |
| (5) Control Rod | R: REAR PTO Position |
| (6) Independent PTO Clutch | R/M: REAR PTO / MID PTO Position |
| (7) PTO Position Selection Section | M: MID PTO Position |
| (8) PTO Shifter | |
| (9) 26T Mid PTO Gear | |
| (10) PTO Clutch Shaft | |
| (11) Rear PTO Rotation Prevention Section | |

9Y1210982TRM0030US0

[2] REAR PTO SECTION

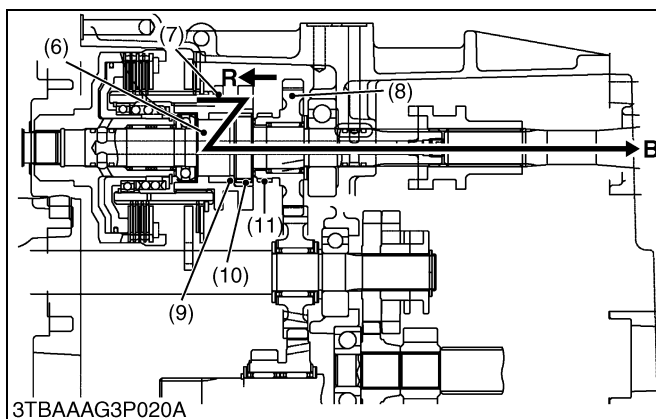
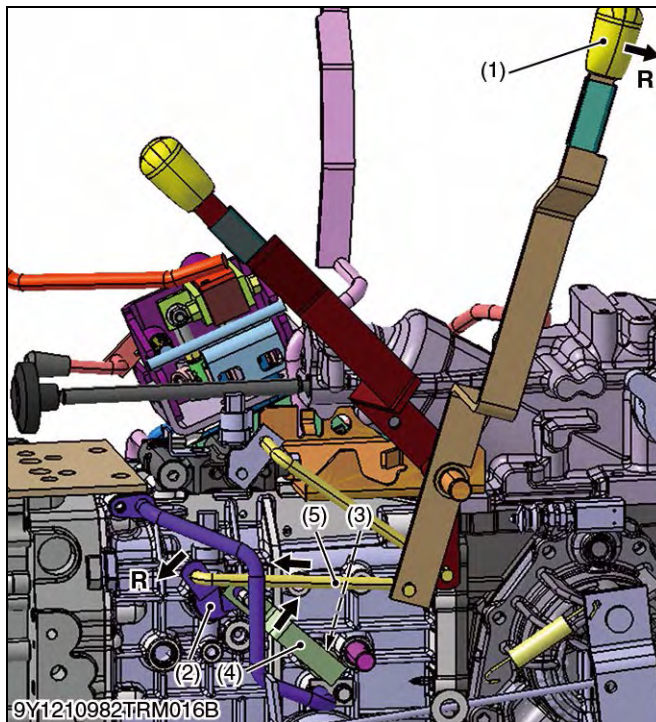
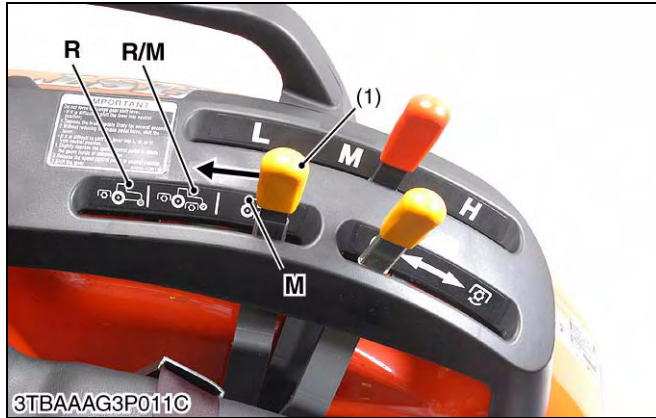

When the PTO shift lever (1) is set to "REAR PTO" (R) position, the PTO shift lever (1) pushes the control rod (5).

The control rod (5) pushes the PTO shift arm (2).

In this state, the PTO shift arm (2) shifts the PTO shifter (7) forward. The inner spline (10) of the PTO shifter (7) meshes the independent PTO shaft spline (9).

Power is transmitted from the independent PTO clutch to the rear PTO shaft as follows.

Independent PTO clutch → PTO shifter (7) → Independent PTO shaft (6) → Rear PTO shifter → Rear PTO shaft.

- | | |
|----------------------------------|---|
| (1) PTO Shift Lever | (10) Inner Spline |
| (2) PTO Shift Arm | (11) 26T Mid Gear Spline |
| (3) Rear PTO Arm | |
| (4) Rear PTO Control Plate | R: REAR PTO Position |
| (5) Control Rod | R/M: REAR PTO / MID PTO Position |
| (6) Independent PTO Shaft | M: MID PTO Position |
| (7) PTO Shifter | B: To Rear PTO Shaft |
| (8) 26T Mid PTO Gear | |
| (9) Independent PTO Shift Spline | |

9Y1210982TRM0031US0

[3] REAR PTO / MID-PTO SECTION

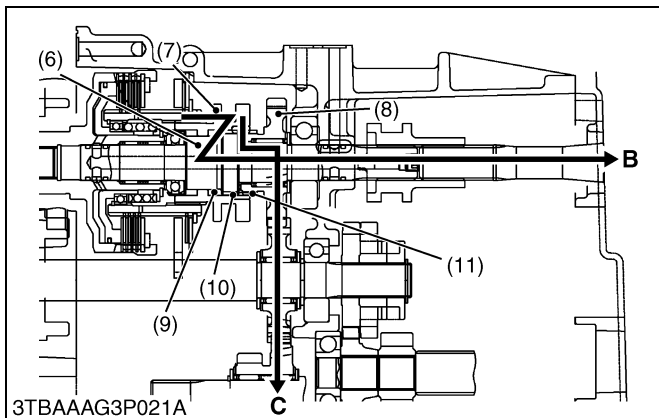
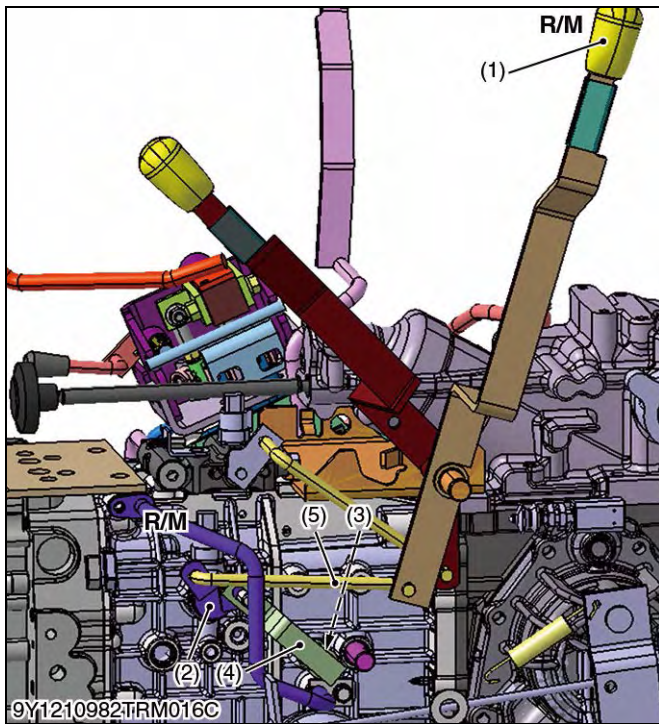
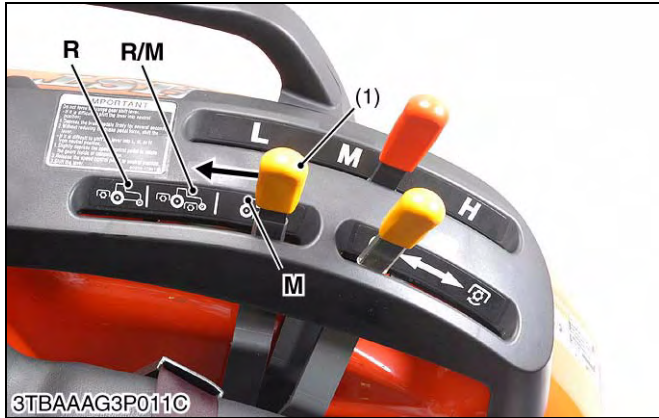

When the PTO shift lever (1) is set to "REAR PTO / MID PTO" (R/M) position, the PTO shift lever (1) pulls the control rod.

The control rod (5) pulls the PTO shift arm (2).

In this state, the PTO shifter (7) keeps its position between the independent PTO shaft spline (9) and the 26T mid gear spline (11).

In this position, the inner spline (10) of the PTO shifter (7) meshes both independent PTO shaft spline (9) and the 26T and gear spline (11).

Power is transmitted from the independent PTO clutch to both the rear PTO shaft and the mid PTO shaft as follows.

■ **Rear PTO Section**

Independent PTO Clutch → PTO shifter (7) → Independent PTO Shaft (6) → Rear PTO shifter → Rear PTO shaft.

■ **Mid PTO Section**

Independent PTO Clutch → PTO shifter (7) → 26T mid gear → 25T gear on front wheel drive shaft → 17T - 26T mid gear → 30T gear → Mid PTO shaft.

- | | |
|----------------------------------|---|
| (1) PTO Shift Lever | (10) Inner Spline |
| (2) PTO Shift Arm | (11) 26T Mid Gear Spline |
| (3) Rear PTO Arm | |
| (4) Rear PTO Control Plate | B: To Rear PTO Shaft |
| (5) Control Rod | C: To Mid PTO Shaft |
| (6) Independent PTO Clutch | R: REAR PTO Position |
| (7) PTO Shifter | R/M: REAR PTO / MID PTO Position |
| (8) 26T Mid PTO Gear | M: MID PTO Position |
| (9) Independent PTO Shaft Spline | |

9Y1210982TRM0032US0

[4] MID-PTO SECTION

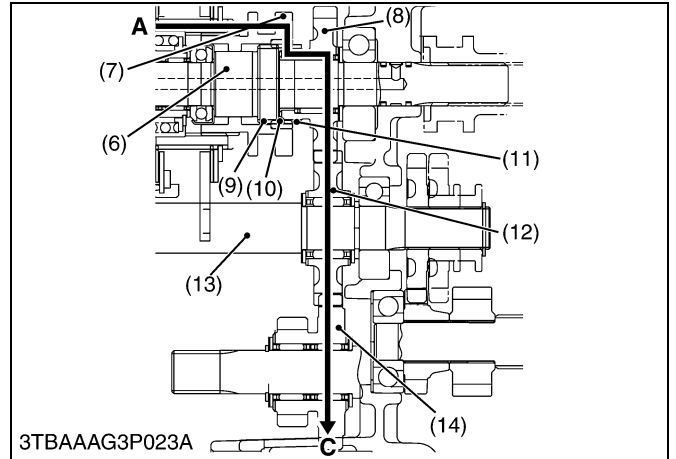
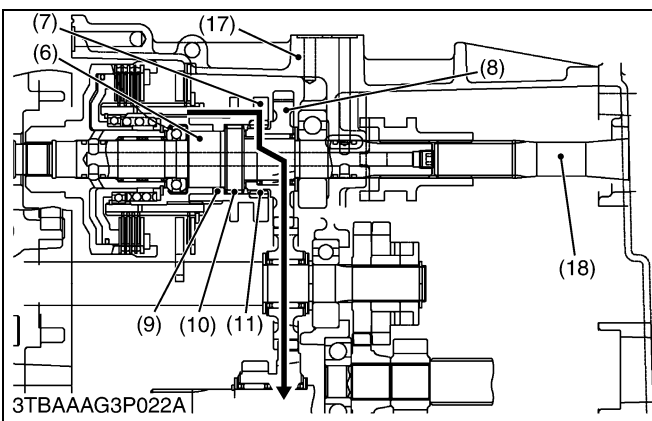
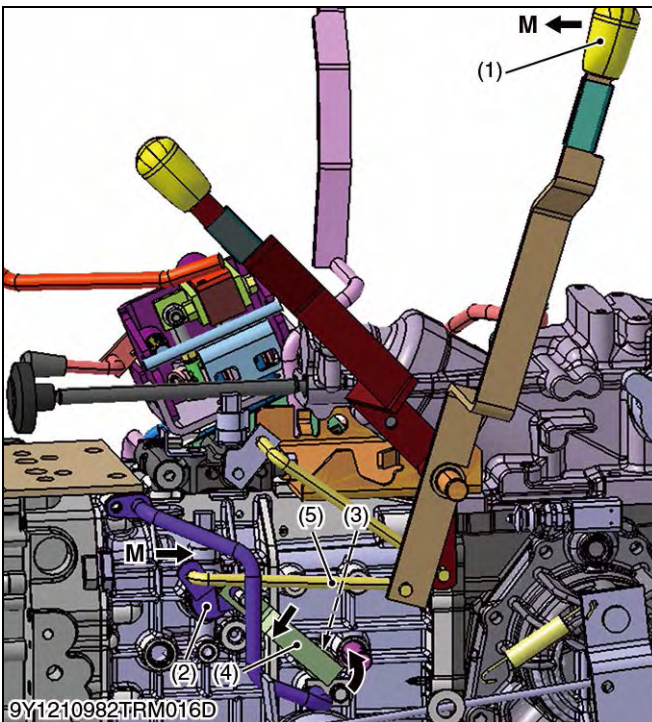
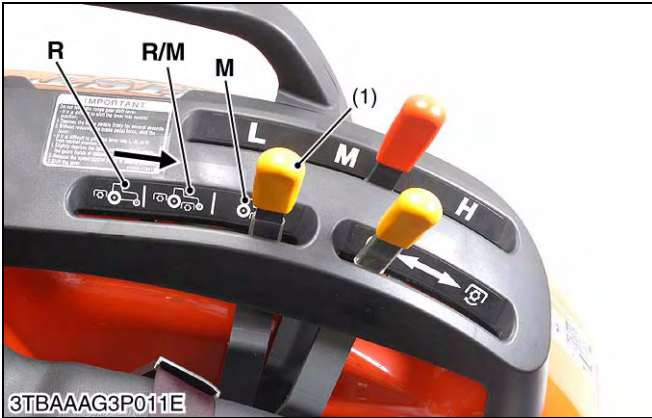

When the PTO shift lever (1) is set to "MID-PTO" (M) position, the PTO shift lever pulls the control rod (5). The control rod (5) pulls the PTO shift arm (2). In this state, the PTO shift arm (2) shifts the PTO shifter (7) reverse. The inner spline of the PTO shifter (7) meshes the 26T Mid PTO gear spline (11).

On the other hand, the range gear shifter arm (2) turns the rear PTO control plate counterclockwise and turns the rear PTO arm counterclockwise.

Since the rear PTO arm is turned counter clockwise, the rear PTO shifter is pushed forward.

Then, the rear PTO shifter meshes the rib of the transmission case.

In this state, the rear PTO brake shifter prevents the independent PTO shaft from rotating itself.

- | | |
|----------------------------------|---|
| (1) PTO Shift Lever | (14) 17T-26T Mid Gear |
| (2) PTO Shift Arm | (15) 30T Gear |
| (3) Rear PTO Arm | (16) Mid PTO Shaft |
| (4) Rear PTO Control Plate | (17) Transmission Case |
| (5) Control Rod | (18) Rear PTO Shaft |
| (6) Independent PTO Clutch | |
| (7) PTO Shifter | A: From Independent PTO Clutch |
| (8) 26T Mid PTO Gear | C: To Mid PTO Shaft |
| (9) Independent PTO Shaft Spline | R: REAR PTO Position |
| (10) Inner Spline | R/M: REAR PTO / MID PTO Position |
| (11) 25T Mid Gear Spline | M: MID PTO Position |
| (12) 25T Gear | |
| (13) Front Wheel Drive Shaft | |

(To be continued)

(Continued)

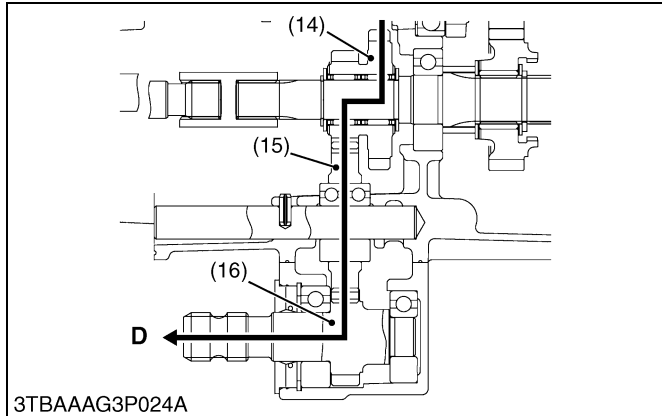

Power is transmitted from the independent PTO clutch to the Mid PTO shaft as follows.

Independent PTO clutch → PTO shifter (7) → 26T mid gear (8) → 25T gear (12) → 17T-26T mid gear (14) → 30T gear (15) → Mid PTO shaft (16).

- (14) 17T-26T id Gear
- (15) 30T Gear
- (16) Mid PTO Shaft

D: To Mid Mount Mower or Front Implement

9Y1210982TRM0033US0

[5] INDEPENDENT PTO (1) Hydraulic Circuit

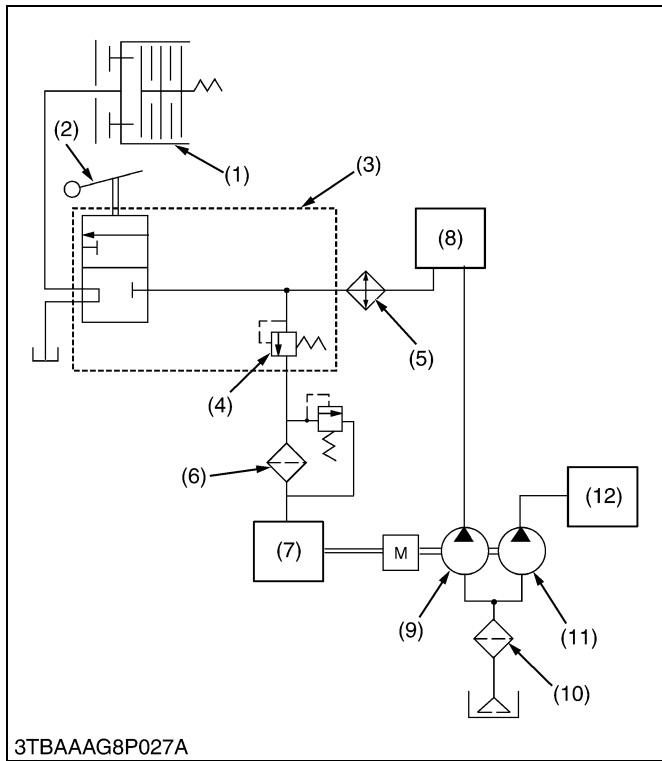

- (1) PTO Clutch
- (2) Independent PTO Lever
- (3) Independent PTO Control Valve
- (4) Relief Valve
- (5) Oil Cooler
- (6) Oil Filter Cartridge (for HST)
- (7) HST
- (8) Power Steering
- (9) Hydraulic Pump (for HST, Power Steering and Independent PTO)
- (10) Oil Filter Cartridge
- (11) Hydraulic Pump (3-Points Hitch)
- (12) 3-Points Hitch

9Y1210982TRM0034US0

(2) Independent PTO Control Valve

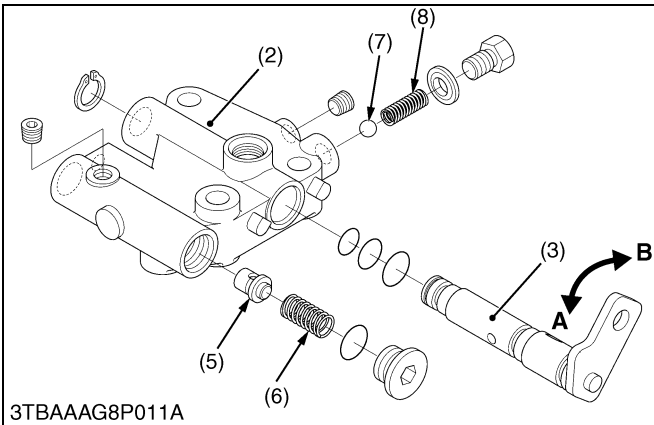
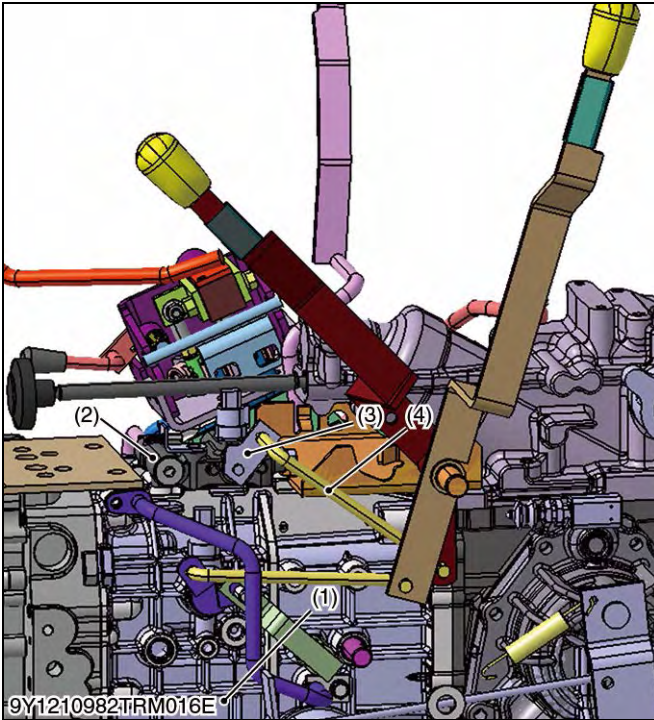

Independent PTO control valve (2) is located at transmission case (1).

The independent PTO control valve (2) consists of PTO arm (3), poppet (5), ball (7) and etc..

The PTO arm (3) is connected to control rod (4) and the independent PTO lever.

The PTO arm (3) is moved to "OFF" or "ON" position by the independent PTO lever.

Oil passage in the PTO arm (3) is turned by the independent PTO lever.

When the PTO arm (3) is moved to "OFF" position, oil in the independent PTO control valve does not flow to the oil passage.

When the PTO arm (3) is moved to "ON" position, oil in the independent PTO control valve flow to the oil passage.

Poppet (5) and spring (6) operate as a relief valve.

- | | |
|-----------------------------------|------------|
| (1) Transmission Case | (6) Spring |
| (2) Independent PTO Control Valve | (7) Ball |
| (3) PTO Arm | (8) Spring |
| (4) Control Rod | |
| (5) Poppet | |

A: PTO arm "OFF" position

B: PTO arm "ON" position

9Y1210982TRM0035US0

(3) Independent PTO Clutch

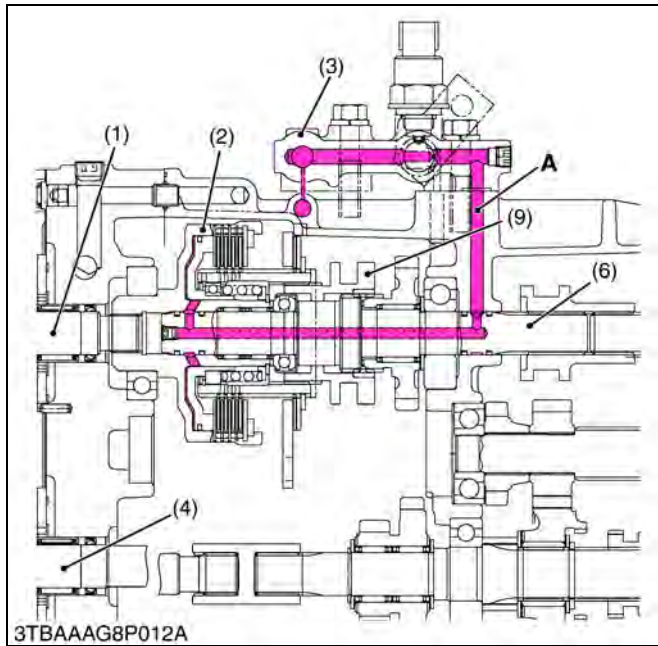

Independent PTO clutch (2) is located behind the HST pump shaft (1) in the transmission case.

Independent PTO clutch (2) is operated with pressured hydraulic oil forced from the independent PTO control valve (3).

When independent PTO lever is shifted to **"ENGAGED"** position, hydraulic oil is forced through the transmission case inner passage (**A**) and PTO clutch shaft (6) to PTO clutch. In this state, power from HST pump shaft is transmitted through independent PTO clutch (2) to independent PTO clutch shaft (6).

When independent PTO lever is shifted to **"DISENGAGED"** position, hydraulic oil is not forced to the PTO clutch. In this state, power from HST pump shaft (1) is not transmitted to independent PTO clutch shaft (6).

- | | |
|-----------------------------------|------------------------------|
| (1) HST Pump Shaft | (7) Seal |
| (2) Independent PTO Clutch | (8) Bearing |
| (3) Independent PTO Control Valve | (9) Shifter |
| (4) HST Motor Shaft | (10) Clutch Discs and Plates |
| (5) Case | (11) Brake Plate 4 |
| (6) PTO Clutch Shaft | (12) Brake Disc |
| | (13) Brake Plate 2 |

9Y1210982TRM0036US0

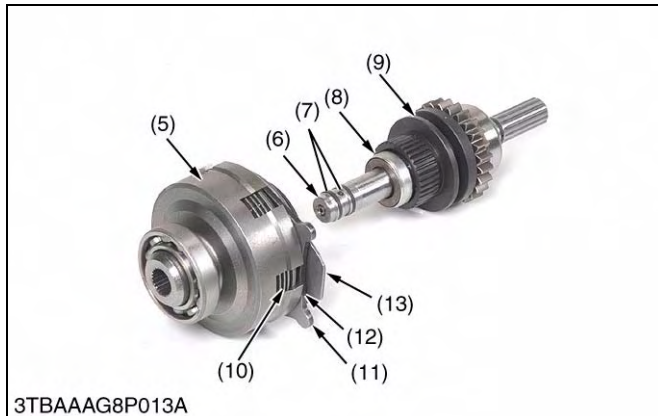

(4) Independent PTO Lever "Engaged"

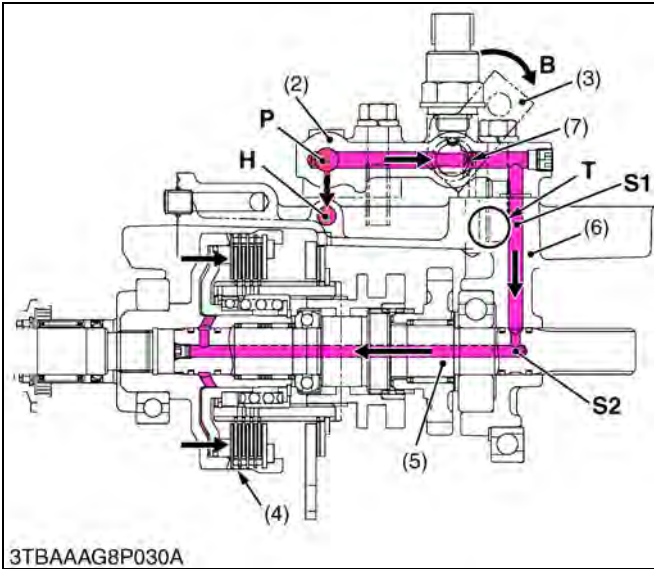
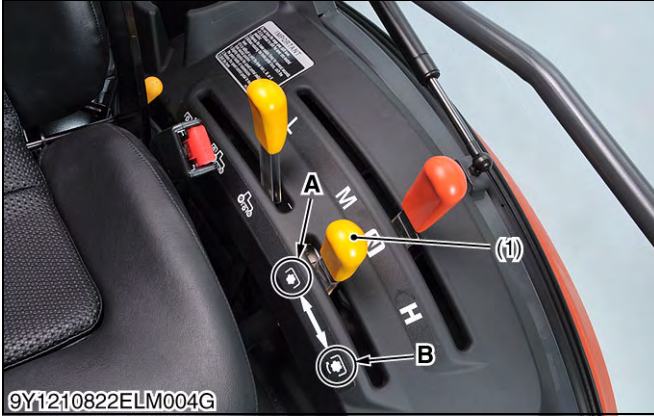

When the independent PTO lever (1) is shifted to the "ENGAGED" position, the PTO arm (3) is turned to "ON" position.

Hydraulic oil from P port flows through oil passage (7) of the PTO arm (3), oil passage S1 in the transmission case (6) and oil passage S2 in the PTO clutch shaft (5) to the PTO clutch (4).

Since the piston of the PTO clutch (4) is pushed by pressurized oil, clutch discs and clutch plates are pushed, and the PTO clutch (4) is engaged.

- | | |
|-----------------------------------|--|
| (1) Independent PTO Lever | A: "DISENGAGED" Position |
| (2) Independent PTO Control Valve | B: "ENGAGED" Position |
| (3) PTO Arm | P: Pump Port |
| (4) PTO Clutch | H: HST Port |
| (5) PTO Clutch Shaft | T: Tank Port |
| (6) Transmission Case | S1: Oil Passage (in the Transmission Case) |
| (7) Oil Passage (in the PTO Arm) | S2: Oil Passage (in the PTO Clutch Shaft) |

9Y1210982TRM0037US0

3TBAAAG8P030A

(5) Independent PTO Lever "Disengaged"

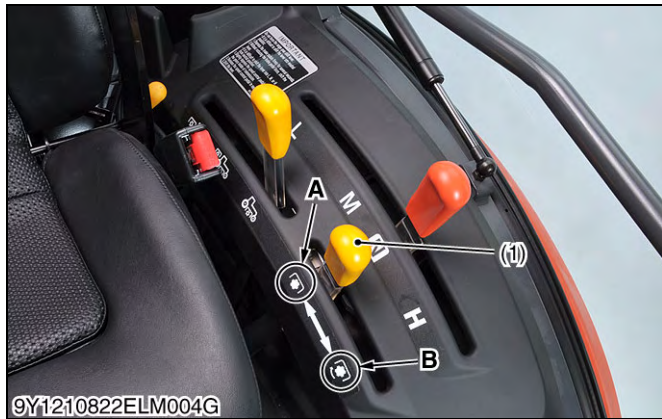

When the independent PTO lever (1) is shifted to the "DISENGAGED" position, the PTO arm (3) is turned to "OFF" position.

Hydraulic oil is stopped at the PTO arm (3).

This oil flows to the HST port.

Oil in the PTO clutch (4) and the PTO clutch shaft (5) drains through oil passage S2, S1 and T port to the transmission case.

- | | |
|-----------------------------------|---|
| (1) Independent PTO Lever | A: "DISENGAGED" Position |
| (2) Independent PTO Control Valve | B: "ENGAGED" Position |
| (3) PTO Arm | P: Pump Port |
| (4) PTO Clutch | H: HST Port |
| (5) PTO Clutch Shaft | T: Tank Port |
| (6) Transmission Case | S1: Oil Passage (in the Transmission Case) |
| | S2: Oil Passage (in the PTO Clutch Shaft) |

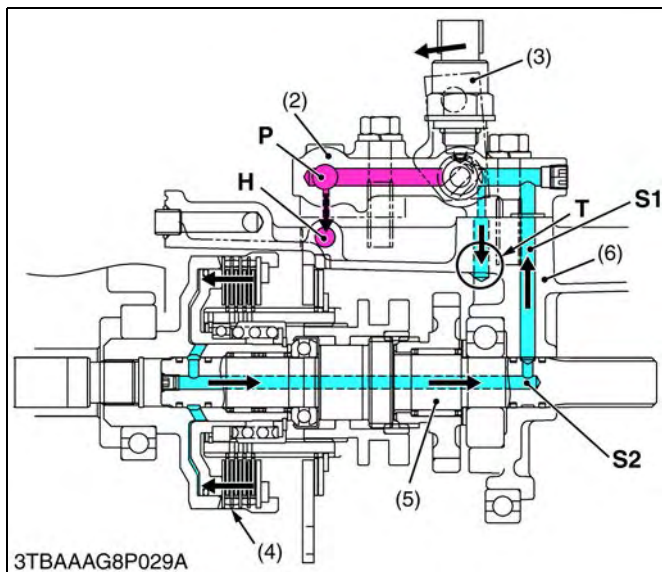

9Y1210982TRM0038US0

9. PTO SYSTEM (MECHANICAL PTO CLUTCH MODEL)

[1] STRUCTURE

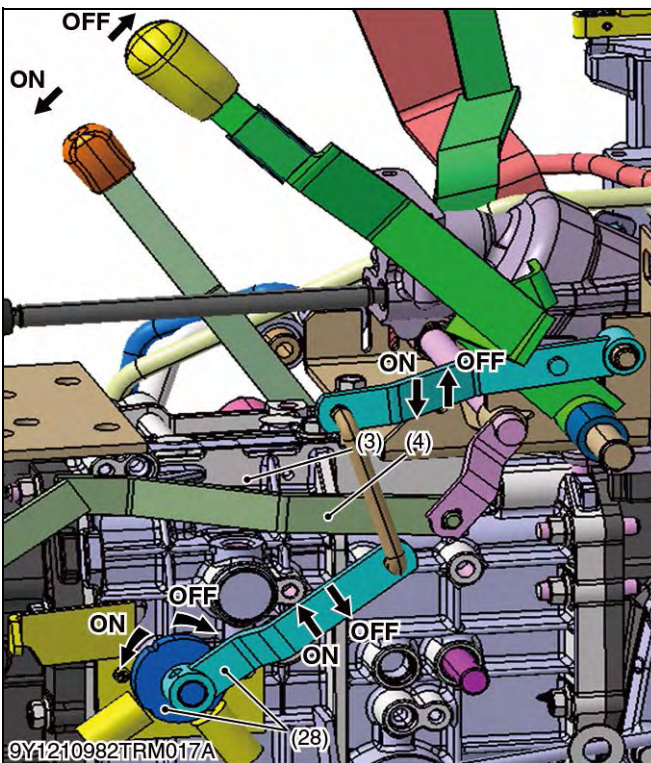
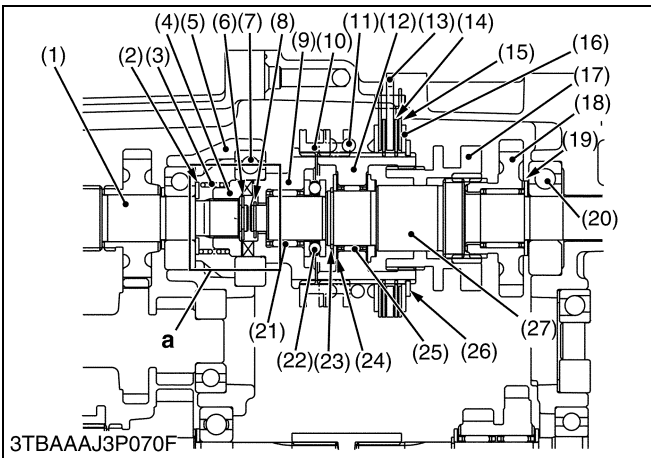

The PTO shift lever location is almost same as the hydraulic PTO clutch model.

The PTO positions are selected to three positions, the "Rear PTO" position (R), the "Rear PTO/ the mid-PTO" position (R/M) and the "Mid-PTO" position (M).

The PTO section is separated into two sections.

The front PTO section is located in the main speed shift case. The rear PTO section is located in the transmission case.

The PTO shifter (17) is mechanically connected to the PTO select lever.

When the PTO ON/OFF shift lever (28) is shifted to "ON" position, the shifter (PTO ON/OFF) (10) slides to the front side and meshes to the one-way clutch spline boss (9).

Since the shifter (PTO ON/OFF) (10) meshes to both the one-way clutch spline boss (9) and the PTO brake spline boss (12), the power is transmitted from the one-way clutch spline boss (9) through the shifter (10) to the PTO brake spline boss (12).

[PTO Brake]

When the mechanical PTO clutch lever is shifted to "OFF (Disengaged)" position, the shifter (10) slides to the PTO brake spring side.

The shifter (10) does not mesh to the one-way clutch spline boss (9), and the power is not transmitted from the one-way clutch spline boss (9) to the PTO brake spline boss (12).

Since the PTO brake spring (11) pushes the brake plate (13) and the PTO brake disks (14), the PTO brake is engaged at this moment.

- | | |
|--------------------------------|-----------------------------|
| (1) First Shift Shaft | (20) Ball Bearing |
| (2) Collar | (21) Needle Bearing |
| (3) Overrunning Clutch Spring | (22) Thrust Ball Bearing |
| (4) One-way Clutch Cam | (23) Cir-clip |
| (5) Bearing Holder | (24) Thrust Collar |
| (6) Cir-clip | (25) Needle Bearing |
| (7) Ball Bearing | (26) Cir-clip |
| (8) Cir-clip | (27) PTO Clutch Shaft |
| (9) One-way Clutch Spline Boss | (28) PTO ON/OFF Shift Lever |
| (10) Shifter (PTO ON/OFF) | (29) PTO ON/OFF Shift Fork |
| (11) PTO Brake Spring | |
| (12) PTO Brake Spline Boss | |
| (13) Brake Plate 2 | |
| (14) Brake Disk | |
| (15) Brake Plate 3 | |
| (16) Brake Plate 1 | |
| (17) PTO Shifter | |
| (18) 26T Mid-gear | |
| (19) Collar (20) | |
- a: One-way Clutch Section**
A: Connected to the PTO Select Lever
R: REAR PTO Position
R/M: REAR PTO / MID PTO Position
M: MID-PTO Position

(To be continued)

(Continued)

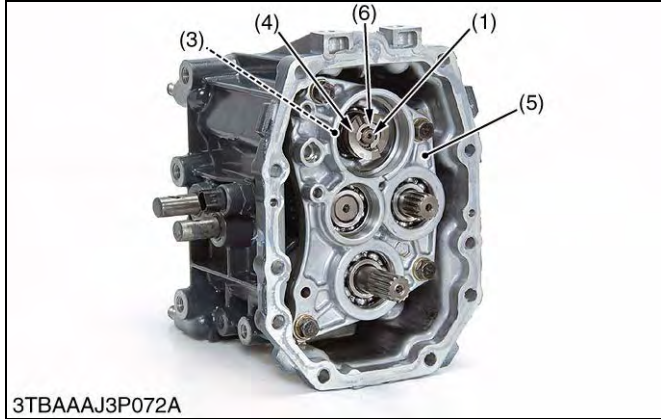

- (1) First Shift Shaft
- (2) One-way Clutch Cam
- (3) Overrunning Clutch Spring
- (4) One-way Clutch Cam
- (5) Bearing Holder
- (6) Cir-clip
- (7) Ball Bearing
- (8) Cir-clip
- (9) One-way Clutch Spline Boss
- (10) Shifter (PTO ON/OFF)
- (27) PTO Clutch Shaft
- (28) PTO ON/OFF Shift Lever
- (29) PTO ON/OFF Shift Folk

9Y1210982TRM0039US0

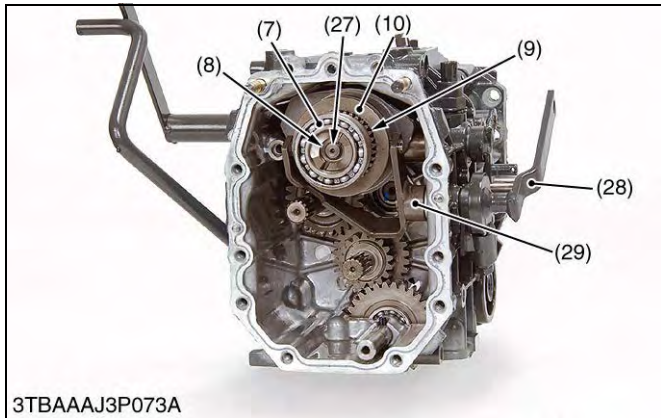

[2] REAR PTO SECTION

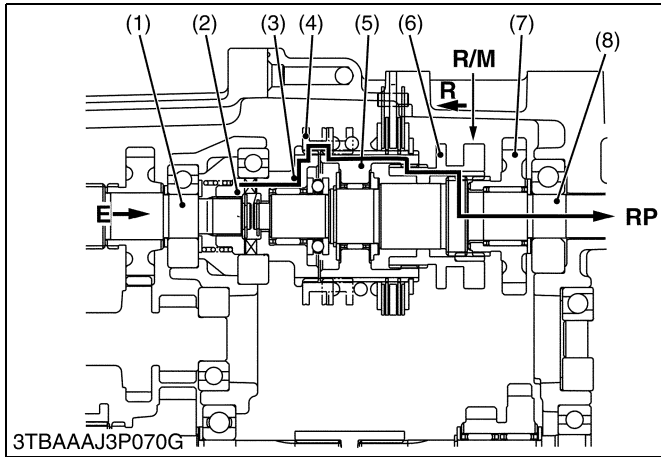

When the PTO shift lever is set to "Rear PTO" position (R), the PTO shifter (6) slides to "Rear PTO" position (R).

The PTO shifter (6) meshes to the spline of the PTO clutch shaft (8).

The power is transmitted from the first shift shaft (1) to the PTO clutch shaft (8) as follows.

First shift shaft (1) → One-way clutch cam (2) → One-way clutch spline boss (3) → shifter (PTO ON/OFF) (4) → PTO brake spline boss (5) → PTO shifter (6) → PTO clutch shaft (8).

- (1) First Shift Shaft
- (2) One-way Clutch Cam
- (3) One-way Clutch Spline Boss
- (4) Shifter (PTO ON/OFF)
- (5) PTO Brake Spline Boss
- (6) PTO Shifter
- (7) 26T Mid Gear
- (8) PTO Clutch Shaft
- E: Power from Engine**
- R: REAR PTO Position**
- R/M: REAR PTO / MID PTO Position**
- RP: Power to Rear PTO Shaft**

9Y1210982TRM0040US0

[3] REAR PTO / MID-PTO SECTION

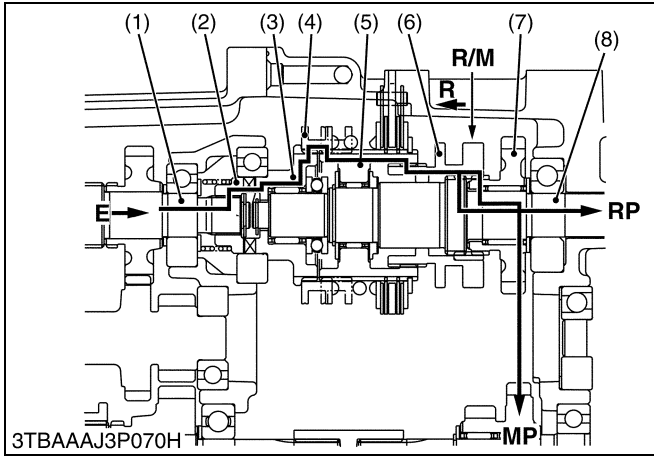

When the PTO shift lever is set to "Rear PTO/Mid-PTO" position, the PTO shifter (6) slides to "Rear PTO/Mid-PTO" position (R/M).

The PTO shifter (6) meshes to both the spline of the PTO clutch shaft (8) and the spline of the 26T mid-PTO gear (7).

The power is transmitted from the first shift shaft (1) to both the rear PTO and the mid-PTO as follows.

■ **To Rear PTO**

First shift shaft (1) → One-way clutch cam (2) → One-way clutch spline boss (3) → shifter (PTO ON/OFF) (4) → PTO brake spline boss (5) → PTO shifter (6) → PTO clutch shaft (8) → to rear PTO (R).

■ **To Mid PTO**

First shift shaft (1) → One-way clutch cam (2) → One-way clutch spline boss (3) → shifter (PTO ON/OFF) (4) → PTO brake spline boss (5) → PTO shifter (6) → 26T mid-gear (7) → 25T gear → to mid-PTO (MP).

- | | |
|--------------------------------|---|
| (1) First Shift Shaft | R: REAR PTO Position |
| (2) One-way Clutch Cam | R/M: REAR PTO / MID PTO Position |
| (3) One-way Clutch Spline Boss | E: Power from Engine |
| (4) Shifter (PTO ON/OFF) | RP: Power to Rear PTO Shaft |
| (5) PTO Brake Spline Boss | MP: Power to Mid-PTO |
| (6) PTO Shifter | |
| (7) 26T Mid Gear | |
| (8) PTO Clutch Shaft | |

9Y1210982TRM0041US0

[4] MID-PTO SECTION

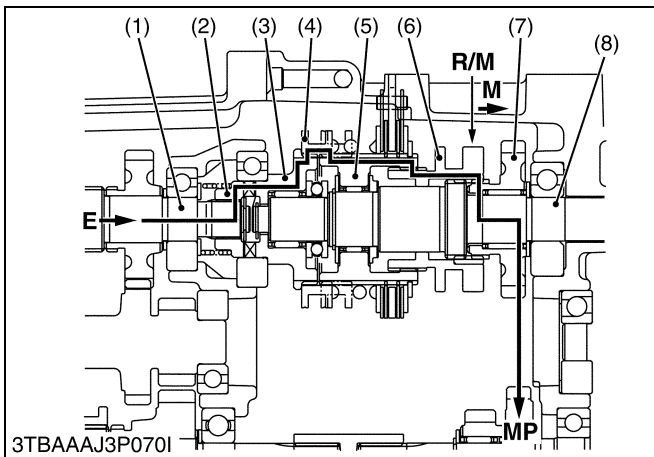

When the PTO shift lever is set to "Mid-PTO" position, the PTO shifter (6) slides to "Mid-PTO" position (M).

The PTO shifter meshes to the spline of the 26T mid-gear (7).

The power is transmitted from the first shift shaft (1) to the mid-PTO as shown in the figure.

- | | |
|--------------------------------|---|
| (1) First Shift Shaft | (10) 30T Gear |
| (2) One-way Clutch Cam | (11) Mid Gear Shaft |
| (3) One-way Clutch Spline Boss | |
| (4) Shifter (PTO ON/OFF) | R/M: REAR PTO / MID PTO Position |
| (5) PTO Brake Spline Boss | M: MID-PTO Position |
| (6) PTO Shifter | E: Power from Engine |
| (7) 26T Mid Gear | MP: Power to Mid-PTO Implement |
| (8) PTO Clutch Shaft | |
| (9) 17T-26T Mid PTO Gear | |

9Y1210982TRM0042US0

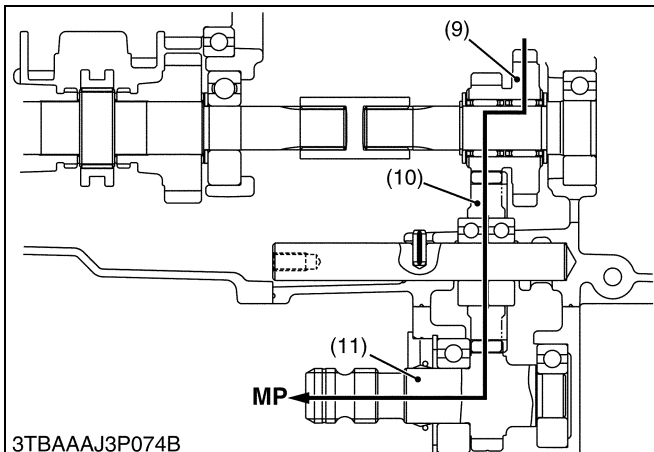

[5] ONE-WAY CLUTCH SYSTEM

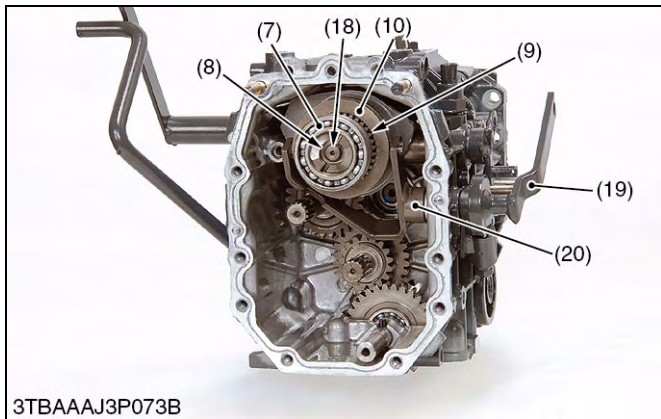
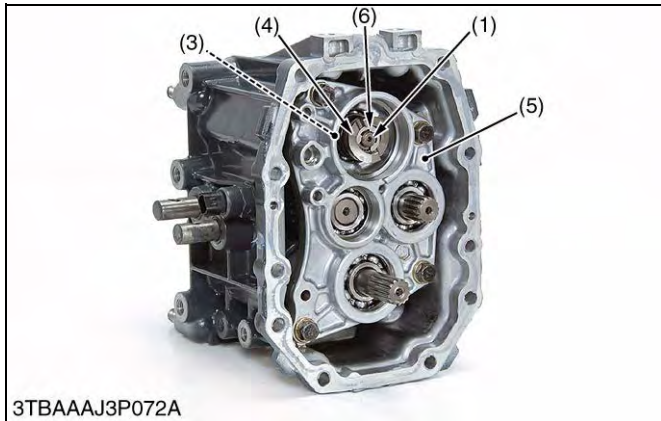
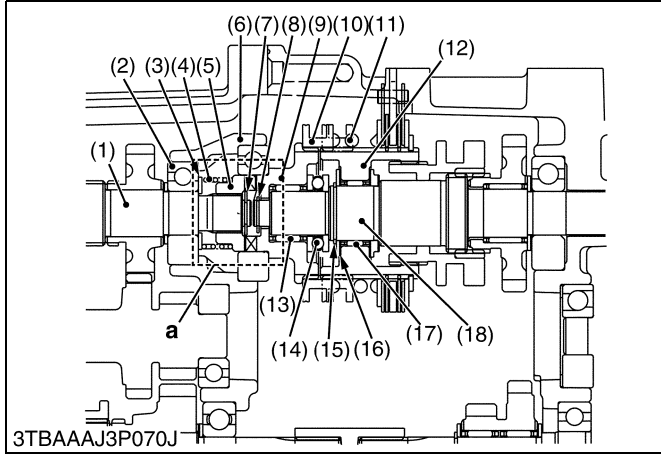

In manual transmission models, a mechanical PTO is adopted.

The one-way PTO clutch is located between the first shift shaft (1) and the PTO clutch shaft (18).

The one-way clutch consists of the first shift shaft (1), the one-way clutch spring (4), the one-way clutch cam (5), the one-way clutch spline boss (9) and the one-way clutch shaft (18).

The one-way clutch cam (15) is splined to the first shift shaft (1), and the one-way clutch spline boss (9) is splined to the PTO clutch shaft (18).

Both the one-way clutch cam (5) and the one-way clutch spline boss (9) are engaged with each other by the force of the one-way clutch spring (4).

While the first shift shaft (1) is driving the PTO clutch shaft (18), both the one-way clutch cam and the one-way clutch spline boss (9) will remain engaged.

However, when the PTO shaft drives a rotary mower, for example, and if the engine speed is lowered, the one-way clutch spline boss (9) on the PTO clutch shaft (18) will overrun.

This overrunning is caused by the inertia of the mower's blades.

Then, engagement will not take place until the first shift shaft (1) is running faster than the one-way clutch PTO clutch shaft (18).

In this way, the one-way clutch protects the transmission and the engine against damage, by allowing the PTO shaft, the first shift shaft (1) and the PTO clutch shaft (18) to overrun if the first shift shaft (1) over speeds.

- | | |
|--------------------------------|-----------------------------|
| (1) First Shift Shaft | (12) PTO Brake Spline Boss |
| (2) Ball Bearing | (13) Needle Bearing |
| (3) Collar | (14) Thrust Ball Baring |
| (4) One-way Clutch Spring | (15) Cir-clip |
| (5) One-way Clutch Cam | (16) Thrust Collar |
| (6) Bearing Holder | (17) Needle Bearing |
| (7) Cir-clip | (18) PTO Clutch Shaft |
| (8) Cir-clip | (19) PTO ON/OFF Shift Lever |
| (9) One-way Clutch Spline Boss | (20) PTO ON/OFF Shift Folk |
| (10) Shifter (PTO ON/OFF) | |
| (11) PTO Brake Spring | |
- a: One-way Clutch Section**

9Y1210982TRM0043US0

10. DIFFERENTIAL GEAR SYSTEM

[1] DIFFERENTIAL FUNCTION

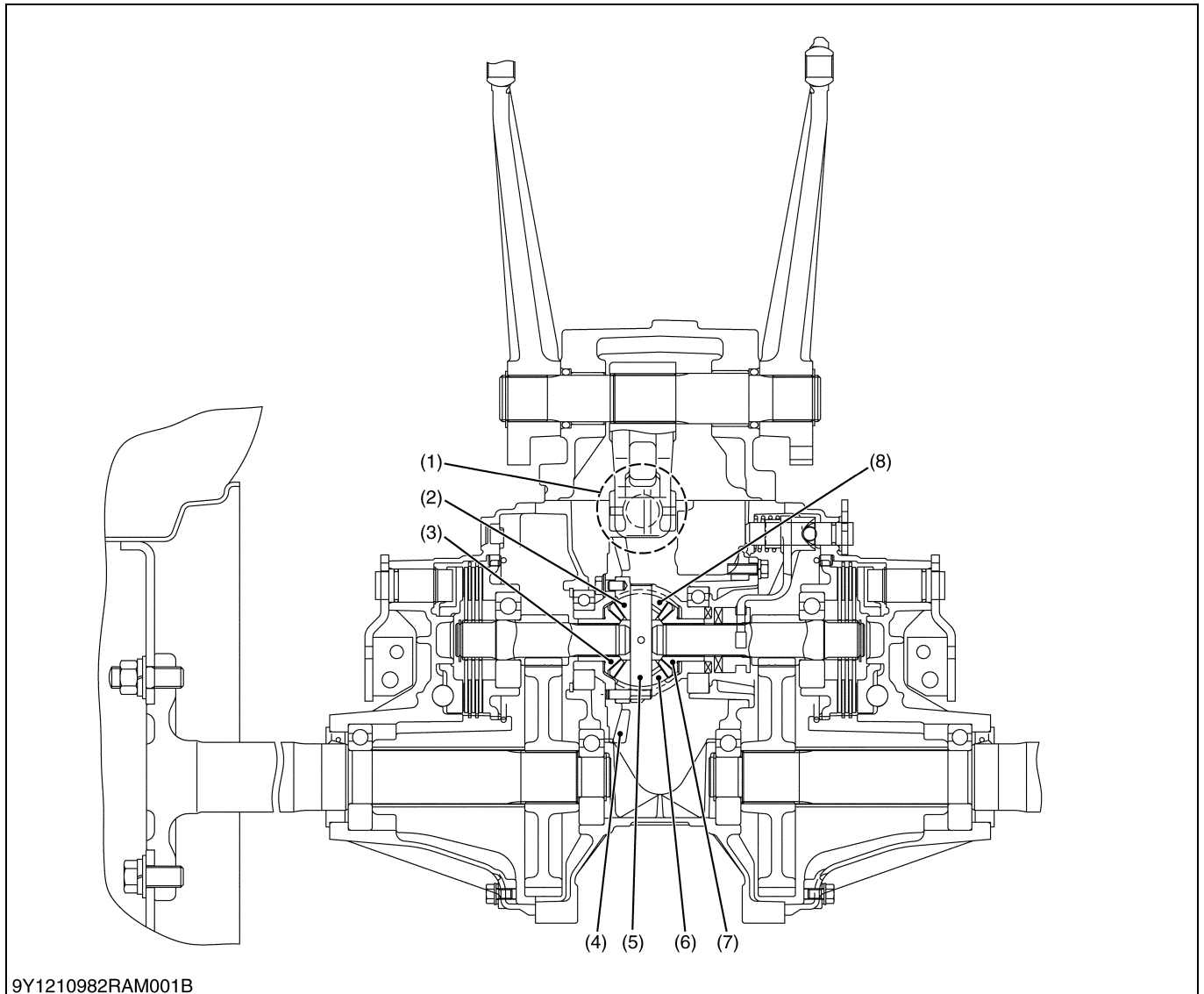

9Y1210982RAM001B

- | | | | |
|-------------------------|----------------------------|-------------------------------|----------------------------|
| (1) Spiral Bevel Pinion | (3) Differential Side Gear | (5) Differential Pinion Shaft | (7) Differential Side Gear |
| (2) Differential Pinion | (4) Spiral Bevel Gear | (6) Differential Pinion | (8) Differential Case |

■ During Straight Running

Rotation of the spiral bevel pinion (1) is transmitted to the spiral bevel gear (4) and differential case (8). When road resistance to the right and left wheels are equal, differential pinions (2), (6) and differential side gears (3), (7) are all rotate as a unit. Both rear axles received equal input, and both wheels turn at the same speed, allowing the tractor to ho straight ahead. At this time, differential pinions (2), (6) does not rotate around the differential pinion shaft (5).

■ During Turning

When the tractor turns, the road resistance to the inside tire increases (as if braking is applied to that side only).

In other words, if one of tires slows down, revolution difference is generated in the differential side gears (3), (7). When rotation of one differential side gear becomes lower than the other, differential pinions (2), (6) begin rotating around differential pinion shaft (5). The other differential side gear is increased in speed by the speed increment of differential pinion shaft (5). This means that rotation of one rear axle is slowed down and that of the other rear axle is increased. Thus, the tractor turns smoothly without power loss.

The combined number of revolutions of the right and left differential side gears is always twice that of the spiral bevel gear (4). When spiral bevel gear revolution is 100 min^{-1} (rpm), and if one of the differential side gears stops moving, the revolution of the other differential side gear becomes 200 min^{-1} (rpm) and if one rotates at 50 min^{-1} (rpm), the other rotates at 150 min^{-1} (rpm).

9Y1210982TRM0044US0

[2] DIFFERENTIAL LOCK

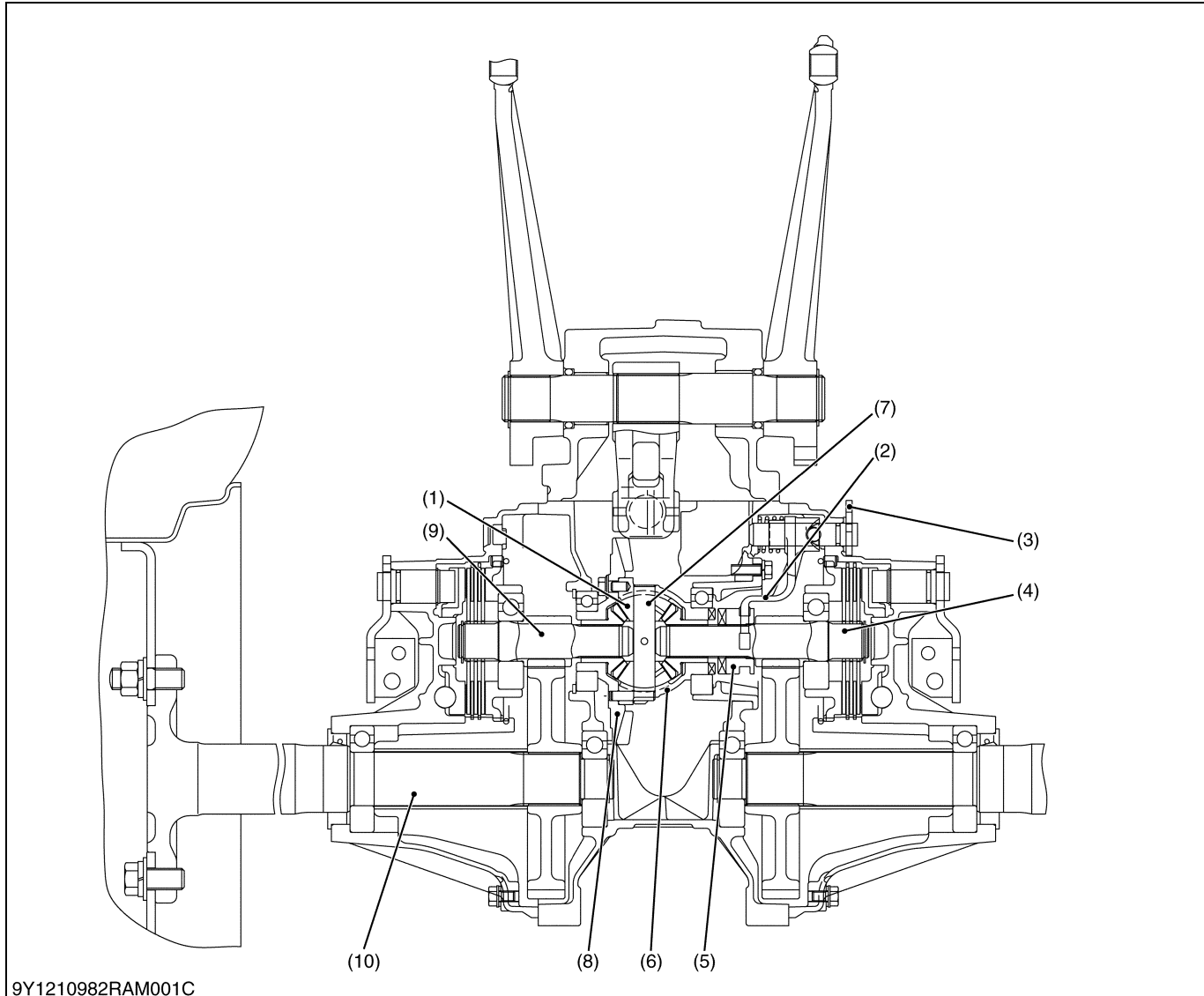

- | | | | |
|-----------------------------|-------------------------------------|-------------------------------|------------------------------------|
| (1) Differential Pinion | (4) Differential Gear Shaft (Right) | (7) Differential Pinion Shaft | (9) Differential Gear Shaft (Left) |
| (2) Shift Fork | (5) Differential Lock Clutch | (8) Spiral Bevel Gear | (10) Rear Axle |
| (3) Differential Lock Lever | (6) Differential Case | | |

When resistance to the right and the left tires are greatly different due to ground conditions or type of work, the tire with less resistance slips and prevents the tractor from moving ahead. To compensate for this drawback, the differential lock restricts the differential action and causes both rear axles to rotate as a unit.

When the differential lock pedal is stepped on, it causes the differential lock lever (3) to rotate. The differential lock lever (3) will move the shift fork (2) and the differential lock clutch (5) toward the spiral bevel gear (8). The differential lock clutch (5) engages with the teeth of the differential case (6) to make the differential case (6) and the differential lock clutch (5) to rotate together as a unit.

Therefore, the differential pinions (1) are unable to rotate around the differential pinion shaft (7) and differential revolutions are transmitted to the right and the left differential gear shaft (4), (9).

9Y1210982TRM0045US0

SERVICING

CONTENTS

1. TROUBLESHOOTING.....	3-S1
2. SERVICING SPECIFICATIONS.....	3-S6
3. TIGHTENING TORQUES.....	3-S8
4. CHECKING, DISASSEMBLING AND SERVICING.....	3-S9
[1] CHECKING AND ADJUSTING.....	3-S9
(1) Bi-Speed Turn.....	3-S9
(2) HST.....	3-S10
(3) Independent PTO Control Valve.....	3-S14
[2] PREPARATION.....	3-S15
(1) Draining Lubricants and Coolant.....	3-S15
(2) Separating Transmission from Tractor Body (CABIN).....	3-S17
(3) Separating Engine and Clutch Housing (CABIN).....	3-S21
(4) Separating Transmission from Tractor Body (ROPS).....	3-S21
(5) Separating Engine and Clutch Housing (ROPS).....	3-S23
[3] DISASSEMBLING AND ASSEMBLING.....	3-S24
(1) Front Case.....	3-S24
(2) Main Gear Shift Section.....	3-S29
(3) Mechanical PTO Clutch Assembly.....	3-S31
(4) Hydrostatic Transmission (HST).....	3-S34
(5) PTO Clutch Case (HST Model).....	3-S44
(6) Bevel Pinion Shaft.....	3-S45
(7) Range Gear Shaft.....	3-S46
(8) Front Wheel Drive Shaft.....	3-S47
(9) Independent PTO Clutch Shifter.....	3-S48
(10)Independent PTO Clutch.....	3-S50
(11)Mid-PTO Section.....	3-S54
(12)Differential Gear Section.....	3-S56
[4] SERVICING.....	3-S57
(1) Bi-Speed Turn Clutch.....	3-S57
(2) Mechanical PTO Clutch.....	3-S57
(3) HST.....	3-S58
(4) Independent PTO Clutch.....	3-S61
(5) Transmission Case.....	3-S62
(6) Differential Gear.....	3-S63

1. TROUBLESHOOTING

HYDROSTATIC TRANSMISSION

Symptom	Probable Cause and Checking Procedure	Solution	Reference Page
System Will Not Operate in Either Direction	1. Oil level is low	Check oil level or fill oil to proper level	3-S15
	2. Speed control pedal linkage damaged	Repair linkage	3-M23
	3. Charge pressure is too low	Solution order 1. Replace oil filter cartridge	G-30, G-35
		2. Check charge pressure	3-S10
		3. Inspect or flush charge relief valve	3-S43
	4. Check and high pressure relief valve does not move smoothly	Inspect or replace check and high pressure relief valve	3-S37
	5. Neutral valve damaged	Inspect or replace neutral valve	3-S39
6. Component parts damaged	Replace hydrostatic transmission assembly	3-S29	
Vibration and Noise	1. Oil level is too low	Check oil level or fill oil to proper level	3-S15
	2. Speed control pedal linkage damaged	Repair linkage	3-M23
	3. Charge pressure is too low	Solution order 1. Replace oil filter cartridge	G-30, G-35
		2. Check charge pressure	3-S10
		3. Inspect or flush charge relief valve	3-S43
	4. Check and high pressure relief valve does not move smoothly	Inspect or replace check and high pressure relief valve	3-S37
	5. Neutral valve damaged	Inspect or replace neutral valve	3-S39
6. Component part is damaged	Replace hydrostatic transmission assembly	3-S29	

Symptom	Probable Cause and Checking Procedure	Solution	Reference Page
Loss of Power	1. Oil level is low	Check oil level or fill oil to proper level	3-S15
	2. Speed control pedal linkage damaged	Repair linkage	3-M23
	3. Charge pressure is too low	Solution order 1. Replace oil filter cartridge	G-30, G-35
		2. Check charge pressure	3-S10
		3. Inspect or flush charge relief valve	3-S43
	4. Check and high pressure relief valve does not move smoothly	Inspect or replace check and high pressure relief valve	3-S37
	5. Neutral valve is damaged	Inspect or replace neutral valve	3-S39
6. Component parts damaged	Replace hydrostatic transmission assembly	3-S29	
Transmission Oil Over Heats	1. Low transmission oil level	Fill transmission oil level up to proper level	3-S15
	2. Radiator net clogged	Clean radiator net	G-16
	3. Improper charge pressure	Solution order 1. Check high relief pressure	3-S11
		2. Replace transmission oil filter cartridge	G-30, G-35
		3. Replace check and high pressure relief valve	3-S37
4. Inspect and replace charge relief valve		3-S43	
Machine Will Not Stop in Neutral Position	1. Speed control linkage is out of adjustment or sticking	Solution order 1. Repair or replace linkage	3-M23
		2. Adjust neutral adjuster	3-M23
	2. Neutral valve damaged	Inspect or replace neutral valve	3-S39
System Operates in One Direction Only	1. Speed control linkage damaged	Repair or replace linkage	3-M23
	2. Check and high pressure relief valve damaged	Replace check and high pressure relief valve	3-S37

FRONT CASE

Symptom	Probable Cause and Checking Procedure	Solution	Reference Page
Noise From Front Case	1. Clutch shaft spline worn	Replace clutch shaft	3-S24
	2. Bearing worn	Inspect or replace bearing	3-S24
	3. Gear worn or broken	Replace gear	3-S25 to 3-S28
	4. Bi-speed turn clutch damaged	Replace Bi-speed turn clutch	3-S25 to 3-S28

TRANSMISSION CASE SECTION

Symptom	Probable Cause and Checking Procedure	Solution	Reference Page	
Noise From Front Transmission	1. Transmission oil insufficient	Check transmission oil	G-8	
	2. Gear worn or broken	Replace transmission gear	3-S29	
	3. Improper backlash between spiral bevel pinion and bevel gear	Inspect or adjust backlash	3-S63	
	4. Improper backlash between differential pinion and differential side gear	Inspect or adjust backlash	3-S63	
	5. Bearings worn	Inspect or replace bearing	3-S61, 3-S62	
	6. PTO clutch damaged	Solution order 1. Check PTO control valve setting pressure		3-S14
		2. Inspect clutch disc or plate		3-S62
3. Replace PTO clutch or other parts			3-S50	

INDEPENDENT PTO

Symptom	Probable Cause and Checking Procedure	Solution	Reference Page
PTO Clutch Slip	1. Operating pressure is low	Solution order 1. Check PTO control valve setting pressure	3-S14
		2. Inspect clutch disc or plate	3-S62
		3. Replace PTO clutch or other parts	3-S50
	2. Independent PTO control valve malfunctioning	Solution order 1. Check PTO control valve setting pressure	3-S14
		2. Inspect or replace poppet or PTO control valve	3-S14
	3. Clutch disc or drive plate excessively worn	Solution order 1. Check PTO control valve setting pressure	3-S14
		2. Inspect or replace clutch disc or plate	3-S62
	4. Deformation of piston or return plate	Solution order 1. Inspect return plate or piston	3-S62
2. Replace return plate or piston		3-S51	
PTO Shaft Does Not Rotate	1. PTO clutch malfunctioning	Solution order 1. Check PTO control valve setting pressure	3-S14
		2. Replace PTO clutch or other parts	3-S50
PTO Clutch Operating Pressure is Low	1. Transmission oil improper or insufficient	Check transmission oil	G-8
	2. Relief valve malfunctioning	Solution order 1. Check PTO control valve setting pressure	3-S14
		2. Replace poppet	3-S14
PTO Clutch Drags	1. Brake plate excessively worn	Replace brake plate	3-S51
	2. Return spring weaken or broken	Inspect or replace return spring	3-S51

DIFFERENTIAL CASE SECTION

Symptom	Probable Cause and Checking Procedure	Solution	Reference Page
Excessive or Unusual Noise at All Time	1. Insufficient or improper type of transmission fluid used	Check transmission oil	G-8
	2. Improper backlash between spiral bevel pinion and bevel gear	Inspect or adjust backlash	3-S63
	3. Improper backlash between differential pinion and differential side gear	Inspect or adjust backlash	3-S63
	4. Bearing worn	Inspect or replace bearing	3-S61, 3-S62
Noise while Turning	1. Differential pinions or differential side gears worn or damaged	Inspect or replace differential pinion or differential side gear	3-S63
	2. Differential lock binding (does not disengage)	Repair or replace differential lock shifter	4-S5
	3. Bearing worn	Inspect or replace bearing	3-S61, 3-S62
Differential Lock Can Not Be Set	1. Differential lock shift fork damaged	Replace differential shift fork	4-S5
	2. Differential lock shifter mounting pin damaged	Replace differential lock shifter	4-S5
Differential Lock Pedal Does Not Return	1. Differential lock fork shaft rusted	Repair or replace differential lock fork shaft	4-S5
	2. Differential lock pedal return spring weakened or damaged	Replace return spring	4-S5

9Y1210982TRS0122US0

2. SERVICING SPECIFICATIONS

BI-SPEED TURN SECTION

Item		Factory Specification	Allowable Limit
Charge Relief Valve	Setting Pressure	0.4 to 0.6 MPa 4.1 to 6.1 kgf/cm ² 58 to 87 psi	–
Clutch Disc	Thickness	1.70 to 1.90 mm 0.067 to 0.075 in.	1.55 mm 0.061 in.
Clutch Disc Plate	Thickness	1.95 to 2.05 mm 0.0768 to 0.0807 in.	1.8 mm 0.071 in.

HYDROSTATIC TRANSMISSION (HST)

Item		Factory Specification	Allowable Limit
Charge Relief Valve	Setting Pressure	0.4 to 0.6 MPa 4.1 to 6.1 kgf/cm ² 58 to 87 psi	–
Check and High Pressure Relief Valve	Setting Pressure [Relief Valve]	33 to 35 MPa 340 to 350 kgf/cm ² 4800 to 5000 psi	–
Relief Valve	Readjusting Pressure	31.4 to 35.3 MPa 320 to 360 kgf/cm ² 4551 to 5120 psi	–
Piston Slipper	Thickness	3.00 mm 0.118 in.	2.90 mm 0.1142 in.
Piston to Bore (HST)	Clearance	0.02 mm 0.0008 in.	0.04 mm 0.0016 in.

INDEPENDENT PTO CLUTCH

Item		Factory Specification	Allowable Limit
Clutch Disc	Thickness	1.70 to 1.90 mm 0.067 to 0.075 in.	1.55 mm 0.061 in.
Clutch Plate	Thickness (With Hole)	1.15 to 1.25 mm 0.045 to 0.049 in.	1.10 mm 0.043 in.
Pressure Plate	Thickness	1.95 to 2.05 mm 0.0768 to 0.0807 in.	1.8 mm 0.071 in.
Piston Return Spring	Free Length	34.5 mm 1.36 in.	–
	Load / Length	614.2 N / 17.8 mm 62.7 kgf / 17.8 mm 138.1 lbf / 0.70 in.	518.7 N / 17.8 mm 53.0 kgf / 17.8 mm 116.6 lbf / 0.70 in.

MECHANICAL PTO CLUTCH

Item		Factory Specification	Allowable Limit
PTO Brake Disc	Thickness	1.70 to 1.90 mm 0.067 to 0.075 in.	1.55 mm 0.061 in.
PTO Brake Plate 1	Thickness	1.95 to 2.05 mm 0.0768 to 0.0807 in.	1.8 mm 0.071 in.

TRANSMISSION CASE AND DIFFERENTIAL GEAR

Item		Factory Specification	Allowable Limit
Shift Fork to Shift Gear Groove	Clearance	0.10 to 0.35 mm 0.0039 to 0.014 in.	0.5 mm 0.02 in.
Differential case to Differential Side Gear	Clearance	0.025 to 0.066 mm 0.0010 to 0.0025 in.	0.3 mm 0.0118 in.
• Differential Case	I.D.	32.000 to 32.025 mm 1.2599 to 1.2608 in.	–
• Spiral Bevel Gear	I.D.	32.000 to 32.025 mm 1.2599 to 1.2608 in.	–
• Differential Side Gear	O.D.	31.959 to 31.975 mm 1.2582 to 1.2589 in.	–
Differential Pinion to Differential Pinion Shaft (B3150)	Clearance	0.048 to 0.084 mm 0.0019 to 0.0033 in.	0.30 mm 0.0118 in.
• Differential Pinion	I.D.	16.032 to 16.050 mm 0.63119 to 0.63188 in.	–
• Differential Pinion Shaft	O.D.	15.966 to 15.984 mm 0.62859 to 0.62929 in.	–
Differential Pinion to Differential Pinion Shaft (B2050, B2350, B2650)	Clearance	0.048 to 0.084 mm 0.0019 to 0.0033 in.	0.30 mm 0.012 in.
• Differential Pinion	I.D.	14.032 to 14.050 mm 0.55244 to 0.55314 in.	–
• Differential Pinion Shaft	O.D.	13.966 to 13.984 mm 0.54985 to 0.55055 in.	–
Differential Pinion to Differential Side Gear	Backlash	0.1 to 0.3 mm 0.0040 to 0.011 in.	0.4 mm 0.016 in.
Spiral Bevel Pinion Shaft	Movements at shaft directions	Approx. 0 mm 0 in.	–
Spiral Bevel Pinion to Spiral Bevel Gear	Backlash	0.10 to 0.30 mm 0.0040 to 0.011 in.	–

9Y1210982TRS0002US0

3. TIGHTENING TORQUES

Tightening torques of screws, bolts and nuts on the table below are especially specified.
(For general use screws, bolts and nuts: See page G-10.)

Item	N·m	kgf·m	lbf·ft
Checking port plug	30 to 44	3.0 to 4.5	22 to 33
Hex. socket head screw	24.5 to 29.5	2.5 to 3.0	18.1 to 21.7
Rear wheel mounting nut [B3150]	167 to 191	17 to 19.5	123 to 141
Rear wheel mounting screw [B3150]	196 to 225	20 to 23	145 to 166
Rear wheel mounting nut and screw [B2650, B2350, B2050]	108 to 126	11.1 to 12.8	79.7 to 92.9
Universal joint mounting bolt	24 to 28	2.5 to 2.8	18 to 20
Cabin mounting bolt and nut	124 to 150	12.7 to 15.2	91.5 to 110
Front loader valve pipe joint bolt	48 to 70	4.9 to 7.1	36 to 51
Sub-frame mounting bolt (M12)	80 to 90	8.2 to 9.1	59 to 66
Sub-frame mounting bolt (M14)	126 to 150	12.9 to 15.2	93.0 to 110
Sub-frame mounting bolt (M10)	40 to 45	4.1 to 4.6	30 to 33
Cabin mount rear frame bolt	90 to 95	9.2 to 9.6	67 to 70
Sub frame mounting nut (M14)	100 to 126	10.2 to 13.0	73.8 to 94.4
Front case mounting bolt for aluminum (M10)	39.3 to 44.1	4.0 to 4.5	29.0 to 32.5
Steel plate mounting bolt (M8)	23.6 to 27.4	2.4 to 2.8	17.4 to 20.2
Bi-Speed Turn clutch shifter mounting flange nut (M18)	9.8 to 11.8	1.0 to 1.2	7.3 to 8.6
Main gear shift section mounting bolt and nut (M10)	39.3 to 44.1	4.0 to 4.5	29.0 to 32.5
Main gear shift bearing holder mounting bolt (M8)	17.7 to 20.5	1.8 to 2.1	13.1 to 15.1
Transmission case mounting bolt and nut (M10)	39.3 to 44.1	4.0 to 4.5	29.0 to 32.5
HST assembly mounting bolt for aluminum (M10)	39.3 to 44.1	4.0 to 4.5	29.0 to 32.5
Center section mounting hex. bolt for aluminum (M10)	39.3 to 44.1	4.0 to 4.5	29.0 to 32.5
Check and high pressure relief valve plug	118 to 147	12.0 to 15.0	86.8 to 108.5
Neutral valve body	58.5 to 68.6	6.0 to 7.0	43.4 to 50.6
Hydraulic cylinder mounting bolt (M10)	39.3 to 44.1	4.0 to 4.5	28.9 to 32.5
Transmission case mounting bolt and nut (M10)	39.3 to 44.1	4.0 to 4.5	29.0 to 32.5
Rear axle case (L.H. and R.H.) mounting bolt (M10)	39.3 to 44.1	4.0 to 4.5	29.0 to 32.5
Rear PTO cover mounting bolt for aluminum (M10)	39.3 to 44.1	4.0 to 4.5	29.0 to 32.5
Differential bearing holder mounting bolt for aluminum (M8)	17.7 to 20.5	1.8 to 2.1	13.1 to 15.1
Valve Plug	118 to 147	12.0 to 15.0	86.8 to 108.5
Neutral Valve Plug	58.5 to 68.6	6.0 to 7.0	43.4 to 50.6

9Y1210982TRS0003US0

4. CHECKING, DISASSEMBLING AND SERVICING

[1] CHECKING AND ADJUSTING

(1) Bi-Speed Turn

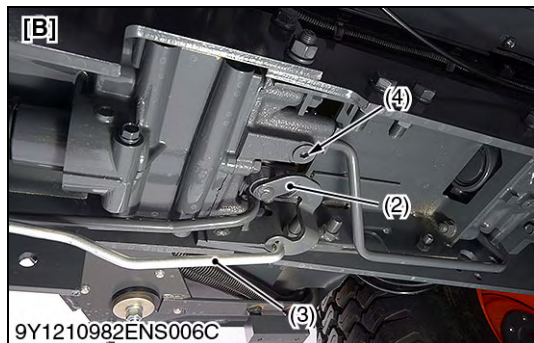
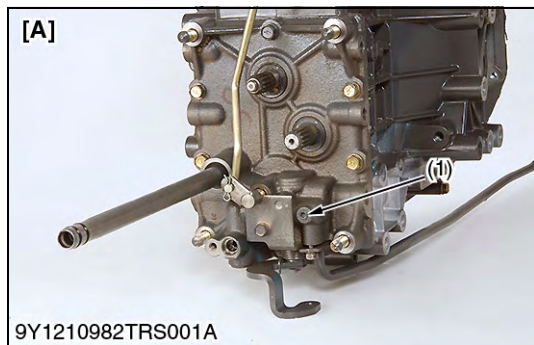

Charge Pressure

CAUTION

- When checking, park the tractor on flat ground and fully engage the parking brake.

1. Remove the plug (R 1/8) (1) at the front case right side (Manual transmission model).
2. Remove the plug (GPF 3/8) (4) at the front case bottom side (HST model).
3. Install the adaptor to the front case.
4. Install the cable and low pressure gauge to the adaptor.

Engine speed	Rated speed
Range gear shift position	Neutral
HST pedal	Neutral

5. Start the engine and warm the transmission fluid before testing.
6. Steer the steering wheel and turn the front wheel above 0.714 rad (42 °).
7. Read the low pressure gauge to measure the charge pressure.
8. If the measurement is not same as factory specification check the Bi-Speed Turn charge valve and the related hydraulic components.

Bi-Speed Turn charge pressure	Factory specification	0.4 to 0.6 MPa 4.1 to 6.1 kgf/cm ² 58 to 87 psi
-------------------------------	-----------------------	--

- (1) Plug (R 1/8)
- (2) Bi-Speed Turn Valve
- (3) Bi-Speed Rod
- (4) Plug (GPF 3/8)

[A] Manual Transmission Model
[B] HST Model

9Y1210982TRS0004US0

(2) HST

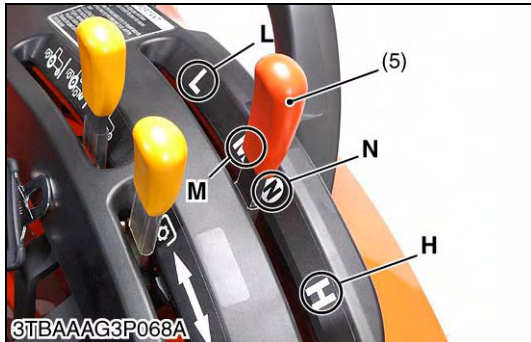
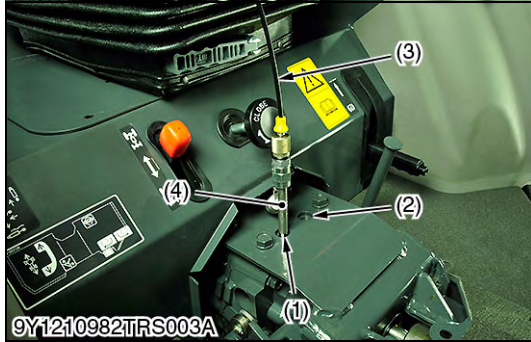
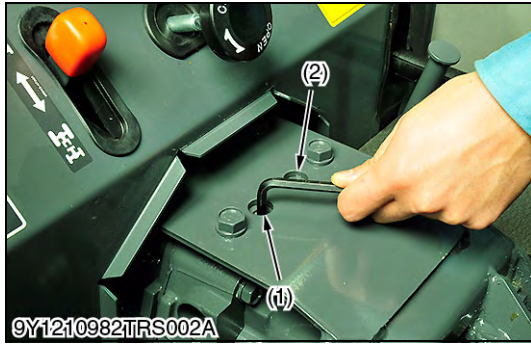

Charge Pressure

⚠ CAUTION

- When checking, park the tractor on flat ground and fully engage the parking brake.

1. Remove the lowering speed adjusting knob and the seat under cover.
2. Remove the plug from P1 port (reverse) or P2 port (forward).

■ NOTE

- If the plug is tight to remove, warm up the plug by a hair drier etc..

3. Install the adaptor (4) to P1 port (1) or P2 port (2).
4. Install the cable (3) and low pressure gauge to the adaptor (4).

Engine speed	Rated speed
Range gear shift position	Neutral
HST pedal	Neutral

5. Start the engine and warm the oil before testing.
6. Change the range gear shift lever (5) to "NEUTRAL" position.
7. Operate the engine at the rated speed.
8. Release the foot from the HST pedal (6).
9. Read the low pressure gauge to measure the charge relief pressure.
10. If the measurement is not same as factory specification, check the charge relief valve and the related hydraulic components.

Charge pressure	Factory specification	0.4 to 0.6 MPa 4.1 to 6.1 kgf/cm ² 58 to 87 psi
-----------------	-----------------------	--

■ NOTE

- Low pressure gauge is 2.9 MPa (30 kgf/cm², 427 psi) full scale.

(When reassembling)

- Apply liquid lock (Three Bond 1375N or its equivalent) to the plug.

Tightening torque	Checking port plug	30 to 44 N·m 3.0 to 4.5 kgf·m 22 to 33 lbf·ft
-------------------	--------------------	---

- (1) P1 Port (Reverse)
- (2) P2 Port (Forward)
- (3) Cable
- (4) Adaptor
- (5) Range Gear Shift Lever
- (6) HST Pedal

- L: Low Speed Position
- M: Medium Speed Position
- N: Neutral Position
- H: High Speed Position

9Y1210982TRS0005US0

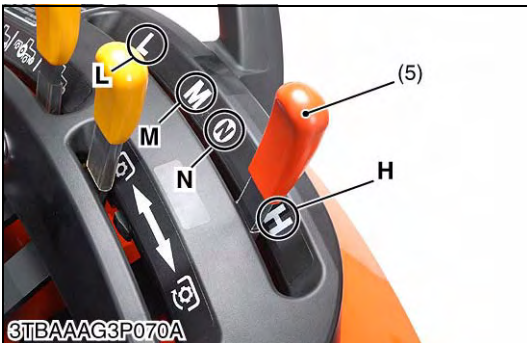
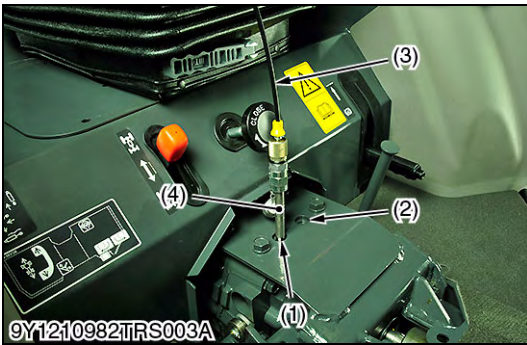
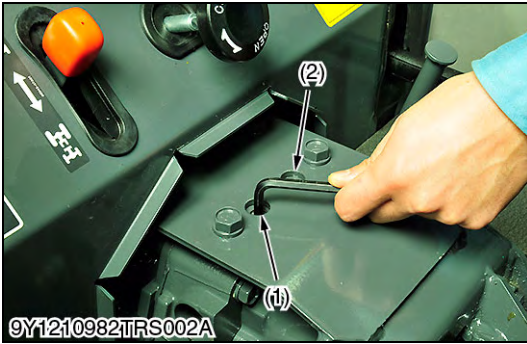

High Pressure Relief Valve Pressure (Reverse)

CAUTION

- When checking, park the tractor on flat ground and fully engage the parking brake.

1. Remove the lowering speed adjusting knob and the seat under cover.
2. Remove the plug from P1 port (reverse).

NOTE

- If the plug is tight to remove, warm up the plug by a hair drier etc..

3. Install the adaptor (4) to P1 port (1).
4. Install the cable (3) and high pressure gauge.

Engine speed	Rated speed
Range gear shift position	High
HST pedal	Reverse
Brake pedal	Depressed

5. Start the engine and warm the oil before testing. Check to see that parking brake is applied.
6. Place the range gear shift lever (5) to "HIGH" position.
7. Operate the engine at the rated speed.
8. Depress the rear side pedal of the HST pedal (6).
9. Read the high pressure gauge to measure the high pressure relief valve pressure.
10. If the measurement is not the same as factory specification, check the check and high pressure relief valve assembly.

Check and high pressure relief valve (Oil temperature at 40 to 60 °C (104 to 140 °F))	Factory specification	33 to 35 MPa 340 to 350 kgf/cm ² 4800 to 5000 psi
--	-----------------------	--

IMPORTANT

- Measure quickly so than the relief valve may not be in operation more than 10 seconds.

NOTE

- High pressure gauge is 40 MPa (400 kgf/cm², 5800 psi) full scale.
- Engine speed: Rated speed
- Oil temperature: 45 to 55 °C (113 to 131 °F)

(When reassembling)

- Apply liquid lock (Three Bond 1324B or its equivalent) to the plug.

Tightening torque	Checking port plug (Reverse)	30 to 44 N·m 3.0 to 4.5 kgf·m 22 to 33 lbf·ft
-------------------	------------------------------	---

- | | |
|----------------------------|---------------------------------|
| (1) P1 Port (Reverse) | L: Low Speed Position |
| (2) P2 Port (Forward) | M: Medium Speed Position |
| (3) Cable | N: Neutral Position |
| (4) Adaptor | H: High Speed Position |
| (5) Range Gear Shift Lever | |
| (6) HST Pedal | |

9Y1210982TRS0006US0

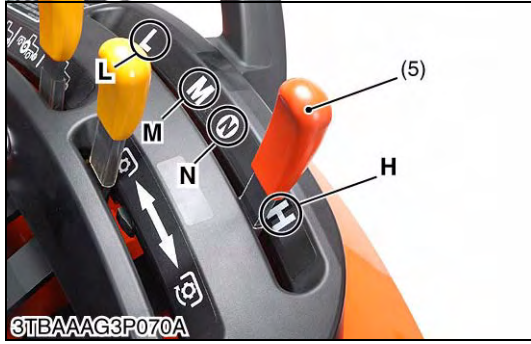
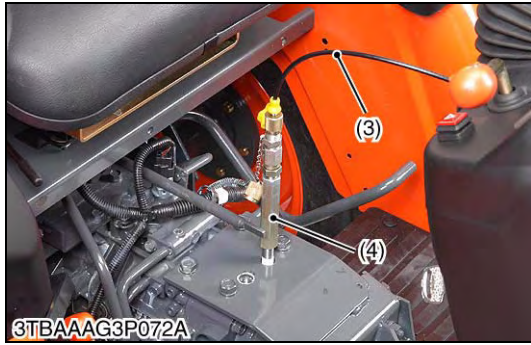
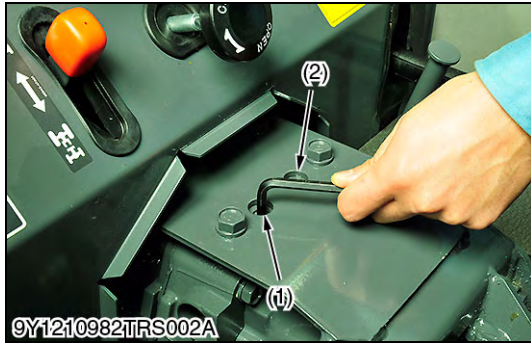

High Pressure Relief Valve Pressure (Forward)

CAUTION

- When checking, park the tractor on flat ground and fully engage the parking brake.

1. Remove the lowering speed adjusting knob and the seat under cover.
2. Remove the plug from P2 port (forward).

NOTE

- If the plug is tight to remove, warm up the plug by a hair drier etc..

3. Install the adaptor (4) to P2 port (1).
4. Install the cable (3) and high pressure gauge.

Engine speed	Rated speed
Range gear shift position	High
HST pedal	Forward
Brake pedal	Depressed

5. Start the engine and warm the oil before testing. Check to see that parking brake is applied.
6. Place the range gear shift lever (5) to "HIGH" position.
7. Operate the engine at the rated speed.
8. Depress the front side pedal of the HST pedal (6).
9. Read the high pressure gauge to measure the high pressure relief valve pressure.
10. If the measurement is not same as factory specification, check the check and high pressure relief valve assembly.

Check and high pressure relief valve (Oil temperature at 40 to 60 °C (104 to 140 °F))	Factory specification	33 to 35 MPa 340 to 350 kgf/cm ² 4800 to 5000 psi
---	-----------------------	--

IMPORTANT

- Measure quickly so that the relief valve may not be in operation more than 10 seconds.

NOTE

- High pressure gauge is 40 MPa (400 kgf/cm², 5800 psi) full scale.
- Engine speed: Rated speed
- Oil temperature: 45 to 55 °C (113 to 131 °F)

(When reassembling)

- Apply liquid lock (Three Bond 1324B or its equivalent) to the plug.

Tightening torque	Checking port plug (Forward)	30 to 44 N·m 3.0 to 4.5 kgf·m 22 to 33 lbf·ft
-------------------	------------------------------	---

- (1) P1 Port (Reverse)
- (2) P2 Port (Forward)
- (3) Cable
- (4) Adaptor
- (5) Range Gear Shift Lever
- (6) HST Pedal

- L: Low Speed Position**
- M: Medium Speed Position**
- N: Neutral Position**
- H: High Speed Position**

9Y1210982TRS0007US0

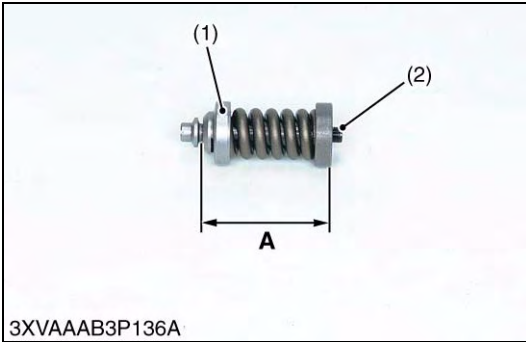

3XVAAAB3P136A

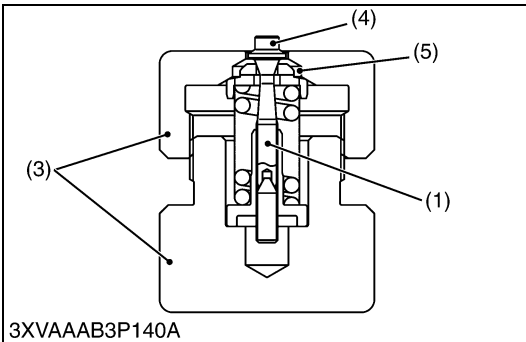

3XVAAAB3P140A

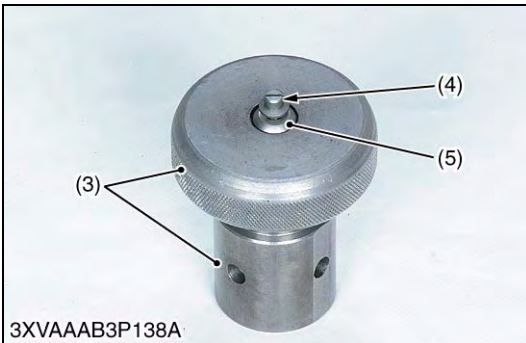

3XVAAAB3P138A

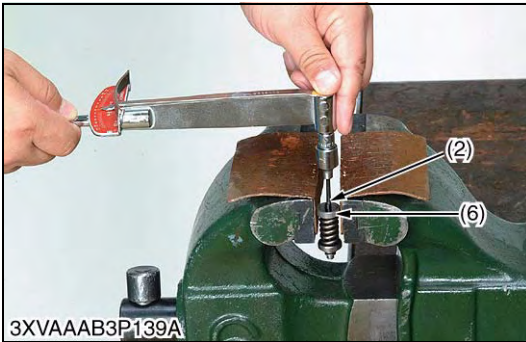

3XVAAAB3P139A

Readjustment of Relief Valve (When the HST does not work due to its loose hexagon socket head screw)

■ **IMPORTANT**

- The KUBOTA does not recommend the readjustment of relief valve. And KUBOTA will recommend to replace with genuine parts.
- As the HST may be damaged if the pressure is set to higher by mistake, be careful when adjusting it.

■ **NOTE**

- The relief pressure is set in between 33.3 to 36.3 MPa (340 to 370 kgf/cm², 4836 to 5262 psi) when shipped from the factory. But, for the purpose of after-sales services, as it is impossible to reset the pressure precisely as set in the factory, its setting range is defined as a slightly wider range between 31.4 to 35.3 MPa (320 to 360 kgf/cm², 4551 to 5120 psi).

1. Measure the pre-adjustment distance "A".
2. Compress the spring of the relief valve with a relief valve assembling tool (3).
3. Then, find the distance "A" by turning the poppet (4) with a screwdriver.

Reference: The distance "A" changes by about 0.5 mm (0.0197 in.) per one turn of the poppet (4).

4. Repeat the same operation a few times to find the distance "A" as it is difficult to acquire at the first time.
5. After finding the distance "A", hold the setscrew (6) to a vice and fasten the hexagon socket head screw (2) with specified torque.

On this occasion, use a copper plate, etc. for the vice jaws not to damage the setscrew (6).

6. Install the relief valve in the HST.
7. Check the relief pressure as indicated in pages 3-S11.
8. If the relief pressure does not fall within the readjustment pressure range, repeat the processes of the above item 1 onward.

Reference: The pressure changes by 1.47 MPa (15 kgf/cm², 213.3 psi) per 0.1 mm (0.0039 in.) in distance "A".

Tightening torque	Hex. socket head screw	24.5 to 29.5 N·m 2.5 to 3.0 kgf·m 18.1 to 21.7 lbf·ft
-------------------	------------------------	---

Relief valve readjusting pressure	Factory specification	31.4 to 35.3 MPa 320 to 360 kgf/cm ² 4551 to 5120 psi
-----------------------------------	-----------------------	--

Distance "A"	Reference value	37.9 to 38.0 mm 1.4921 to 1.4960 in.
--------------	-----------------	---

- | | |
|----------------------------------|----------------|
| (1) Relief Valve Assembly | (4) Poppet |
| (2) Hexagon Socket Head Screw | (5) Valve Seat |
| (3) Relief Valve Assembling Tool | (6) Setscrew |

9Y1210982TRS0008US0

(3) Independent PTO Control Valve

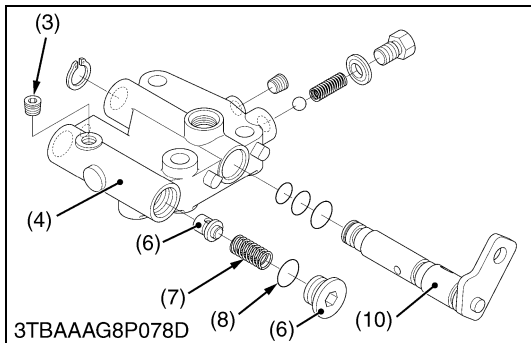
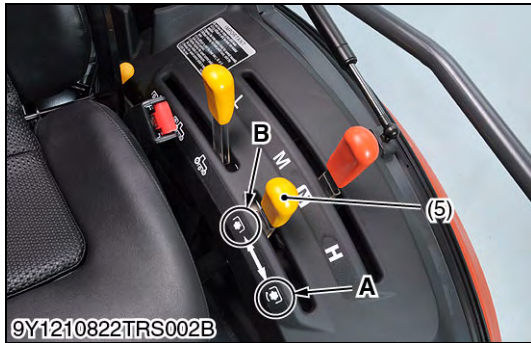
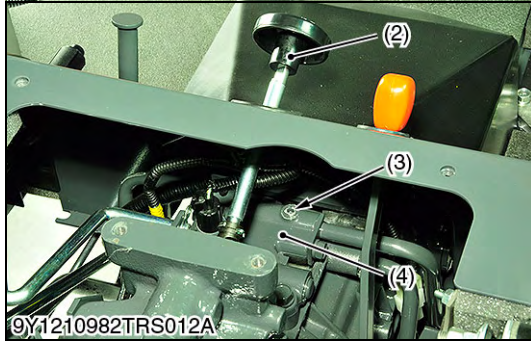
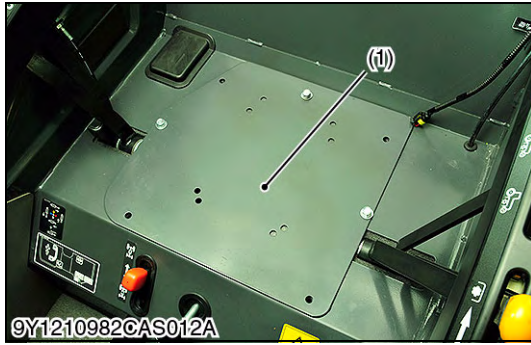

Independent PTO Control Valve Setting Pressure

1. Disconnect the OPC switch connector and remove the seat.
2. Remove the plate (1).
3. Remove the 3-point hitch lowering speed knob (2).
4. Remove the plug (3) with a hexagon wrench.
5. Install the adapter to the independent PTO control valve (4).
6. Connect the cable and the pressure gauge to the adapter (2).
7. Reassemble the plate (1).
8. Start the engine and set at the maximum speed. (Pressure at **"ENGAGED"** position)
9. Move the independent PTO lever (5) to **"ENGAGED"** position **A**.
10. Measure the pressure. (Pressure at **"DISENGAGED"** position)
11. Move the independent PTO lever (5) to position **B**.
12. Measure the pressure.
13. If the pressure is not the factory specifications, adjust setting pressure with (the adjusting) shims.

Independent PTO valve setting pressure	Independent PTO lever "ENGAGED" position	1.1 to 1.5 MPa 11.2 to 15.3 kgf/cm ² 160 to 218 psi
	Independent PTO lever "DISENGAGED" position	0 MPa 0 kgf/cm ² 0 psi

Condition

- Engine speed : Maximum
- Oil temperature : 50 °C (122 °F)

- | | |
|---------------------------------------|-------------------------------|
| (1) Plate | (8) O-ring |
| (2) 3-Point Hitch Lowering Speed Knob | (9) Plug |
| (3) Plug | (10) PTO Arm |
| (4) Independent PTO Control Valve | |
| (5) Independent PTO Lever | A: ENGAGED Position |
| (6) Poppet | B: DISENGAGED Position |
| (7) Spring | |

9Y1210982TRS0123US0

[2] PREPARATION

(1) Draining Lubricants and Coolant

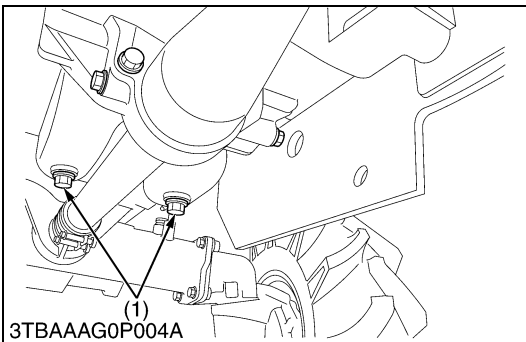
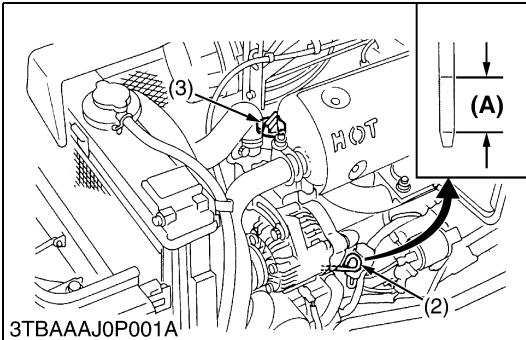

Draining Engine Oil

CAUTION

- **Before changing oil, be sure to stop the engine.**
1. Start and warm up the engine for approx. 5 minutes.
 2. Place an oil pan underneath the engine.
 3. To drain the used oil, remove the drain plug (1) at the bottom of the engine and drain the oil completely.
 4. Screw in the drain plug (1).
 5. Fill new oil up to upper line on the dipstick (2).

IMPORTANT

- **When using an oil of different manufacture or viscosity from the previous one, remove all of the old oil.**
 - **Never mix two different types of oil.**
 - **Use the proper SAE Engine Oil according to ambient temperatures.**
- Refer to G-8.**

Engine oil capacity	B2050, B2350	3.1 L 3.3 U.S.qts 2.8 Imp.qts
	B2650, B3150	4.0 L 4.2 U.S.qts 3.5 Imp.qts

- (1) Drain Plug
- (2) Dipstick
- (3) Oil Inlet Plug

(A) Oil level is acceptable within this range.

9Y1210982ENS0023US0

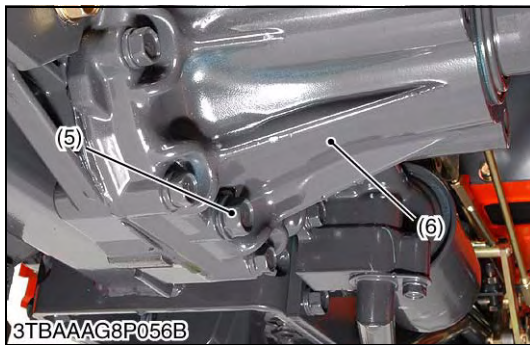
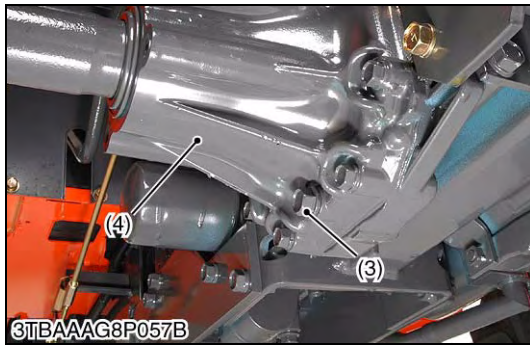

Draining Transmission Fluid

CAUTION

• Stop the engine before checking and changing the transmission fluid.

1. Place the oil pan under the tractor.
2. Remove the drain plugs (1), (3), (5) at the mid-PTO shaft and at the bottom of the rear axle cases (4), (6).
3. Drain the transmission fluid.
4. After draining the transmission fluid, reinstall the drain plugs (1), (3), (5).

IMPORTANT

- Use only KUBOTA UDT oil. Use of other oils may damage the transmission or hydraulic system. Refer to G-8.
- Never work the tractor immediately after changing the transmission oil. Keep the engine at medium speed for a few minutes to prevent damage to the transmission.
- Do not mix different brands oil together.

Transmission fluid capacity	B2050, B2350, B2650 Manual transmission	16.5 L 4.4 U.S.gals 3.6 Imp.gals
	B2350HST B2650HST B3150HST	17 L 4.5 U.S.gals 3.7 Imp.gals

- | | |
|-------------------|---------------------------|
| (1) Drain Plug | (4) Rear Axle Case (L.H.) |
| (2) Mid-PTO Shaft | (5) Drain Plug |
| (3) Drain Plug | (6) Rear Axle Case (R.H.) |

9Y1210982ENS0024US0

Battery Cable

1. Open the bonnet and remove the side cover and bonnet.
2. Disconnect the battery negative cable (1).

NOTE

• When disconnecting the battery cables, disconnect the grounding cable first. When connecting, the positive cable first.

- (1) Battery Negative Cable

9Y1210982CAS0057US0

Rear Wheel and 3-Point Linkage

1. Place the disassembling stand under the transmission case.
2. Remove the rear wheel (1).
3. Remove the top link, lower links and lift rods.

Tightening torque	Rear wheel mounting nut	B3150	167 to 191 N·m 17 to 19.5 kgf·m 123 to 141 lbf·ft
	Rear wheel mounting screw		196 to 225 N·m 20 to 23 kgf·m 145 to 166 lbf·ft
	Rear wheel mounting nut and screw	B2650 B2350 B2050	108 to 126 N·m 11.1 to 12.8 kgf·m 79.7 to 92.9 lbf·ft

- (1) Rear Wheel

9Y1210982CAS0058US0

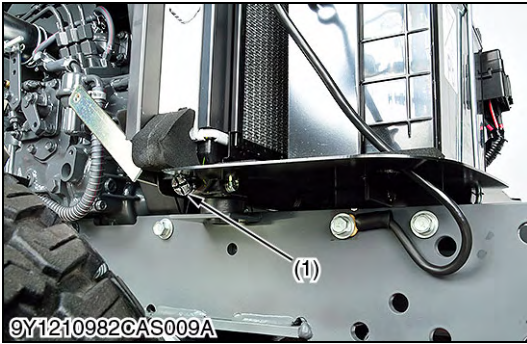

Draining Coolant

⚠ CAUTION

- Never remove the radiator cap until coolant temperature is well below its boiling point. Then loosen cap slightly to the stop to relieve any excess pressure before removing cap completely.

1. Stop the engine and let cool down.
2. To drain the coolant, turn the drain plug (1) counterclockwise.
3. Remove the radiator cap to completely drain the coolant.
4. After all coolant is drained, reinstall the radiator drain plug.

(When reassembling)

Coolant	Capacity	4.3 L 4.5 U.S.qts 3.8 Imp.qts
---------	----------	-------------------------------------

(1) Drain Plug

9Y1210982CAS0076US0

(2) Separating Transmission from Tractor Body (CABIN)

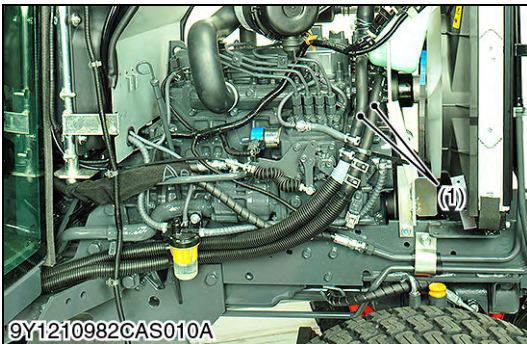

Heater Hose

1. Disconnect the heater hoses (1), and then reconnect their hoses to make loop.

■ NOTE

- Put a mark to the each heater hoses before disconnecting.

(1) Heater Hose

9Y1210982TRS0009US0

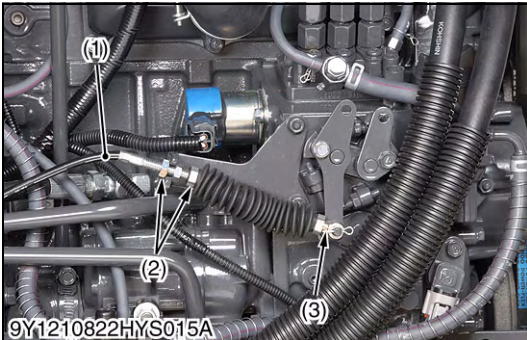

Accelerator Wire

1. Disconnect the accelerator wire (1).

(When reassembling)

- Set the end of wire inner (3) first. Then adjust the length of the wire outer section so that the wire inner section has no play, and tighten the lock nut (2).

(1) Accelerator Wire
(2) Lock Nut

(3) Accelerator Inner

9Y1210982TRS0010US0



Seat and Lever Guide

1. Disconnect the OPC switch connector and remove the seat (1).
2. Remove the each lever grips (2).
3. Remove the lever guides (3).

(1) Seat
(2) Lever Grip

(3) Lever Guide

9Y1210982TRS0011US0

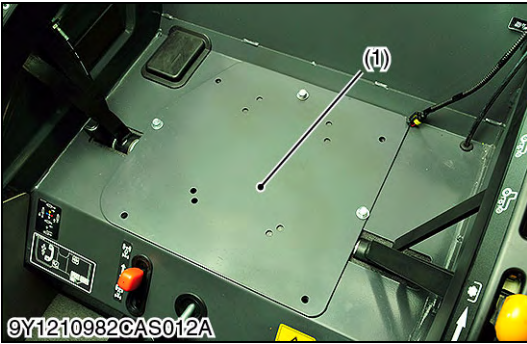

Seat Under Cover

1. Remove the seat under cover (1).

(1) Seat Under Cover

9Y1210982TRS0012US0

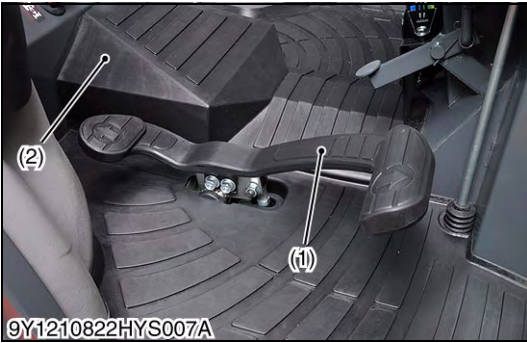

HST Pedal and Floor Mat

1. Remove the HST pedal (1) and floor mat (2).

(1) HST Pedal (2) Floor Mat

9Y1210982TRS0013US0

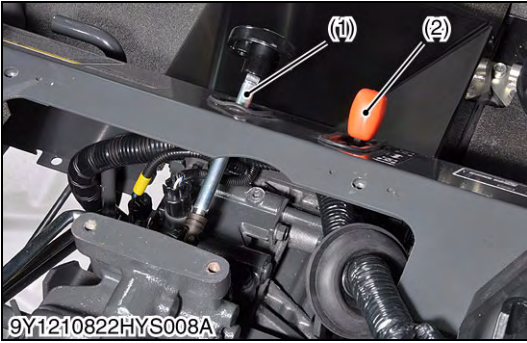

Lowering Speed Adjusting Shaft and Front Wheel Drive Lever Knob

1. Tap out the spring pin and remove the lowering speed adjusting shaft (1).
2. Remove the front wheel drive lever knob (2).

(1) Lowering Speed Adjusting Shaft (2) Front Wheel Drive Lever Knob

9Y1210982TRS0014US0

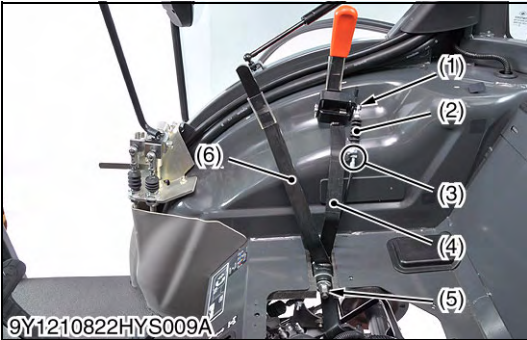

Position Control Lever and Cruise Control Lever

1. Remove the cruise control cable (2) from cruise control lever (4).
2. Remove the lever mounting nut (5), cruise control lever (4) and position control lever (6).

(When reassembling)

- Set the end of cable inner first. Then adjust the length of the cruise control cable outer section so that the cable inner section (1) has no play, and tighten the lock nut (3). (Due to a force of the spring in cruise control lever (4), the lever is set to the right side (outside) from the operator's seat.)

(1) Cable Inner Section (4) Cruise Control Lever
 (2) Cruise Control Cable (5) Lever Mounting Nut
 (3) Lock Nut (6) Position Control Lever

9Y1210982TRS0015US0

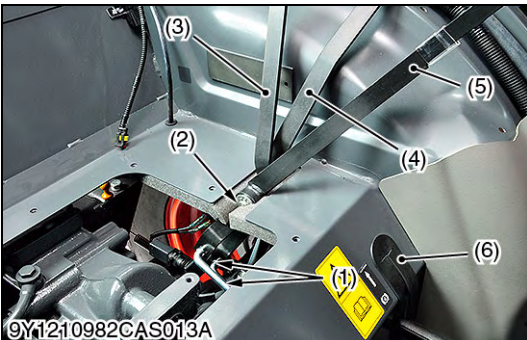

Range Gear Shift Lever, PTO Clutch Lever, PTO Select Lever and Rubber Cover

1. Remove the spring lock pins from shift rods (1).
2. Remove the external circlip (2), range gear shift lever (3), PTO clutch lever (5), and PTO select lever (4).
3. Remove the rubber cover for parking brake lever (6).

(1) Shift Rod (4) PTO Select Lever
 (2) External Circlip (5) PTO Clutch Lever
 (3) Range Gear Shift Lever (6) Rubber Cover

9Y1210982TRS0016US0

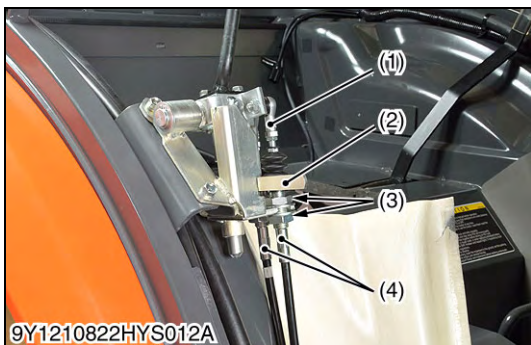

Front Loader Cables

- Loosen the lock nuts (3) and remove the front loader cables (4).
(When reassembling)
 - Set the lock lever (2) to lock position.
 - Fix the ball joint (1) first.
 - Adjust the length of the front loader cable (4) outer section so that the cable inner section has no play, and tighten the lock nut (3).

- (1) Ball Joint
- (2) Lock Lever
- (3) Lock Nut
- (4) Front Loader Cable

9Y1210982TRS0017US0

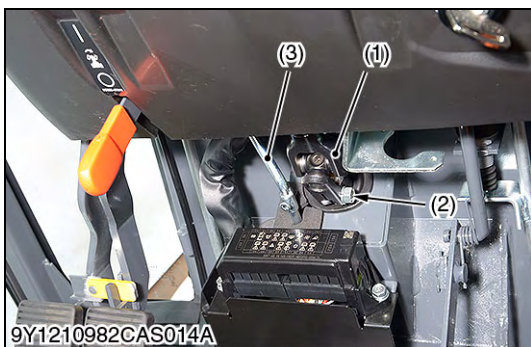

Universal Joint Mounting Bolt and Bi-speed Rod

- Remove the universal joint mounting bolt (2).
- Disconnect the Bi-speed rod (3).

(When reassembling)

Tightening torque	Universal joint mounting bolt	24 to 28 N·m 2.5 to 2.8 kgf·m 18 to 20 lbf·ft
-------------------	-------------------------------	---

- (1) Universal Joint
- (2) Bolt
- (3) Bi-speed Rod

9Y1210982TRS0018US0

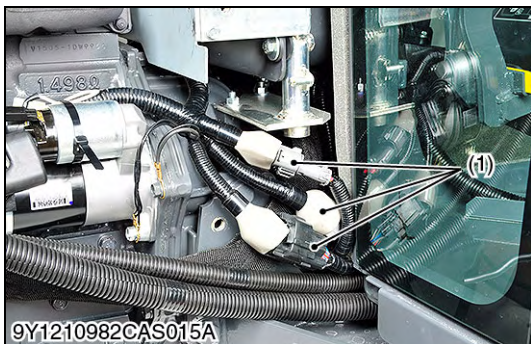

Electric Wiring

- Disconnect the wiring connectors (1).

- (1) Wiring Connector

9Y1210982TRS0019US0

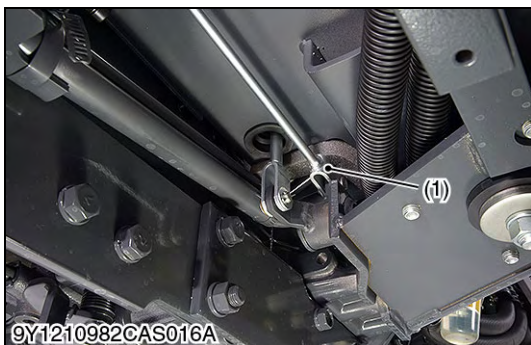

Brake Pedal Rods

- Disconnect the both left and right sides brake pedal rods (1).

- (1) Brake Pedal Rod

9Y1210982TRS0020US0



Cabin Mounting Bolts

1. Remove the bolts and nuts (1).
(When reassembling)

Tightening torque	Cabin mounting bolt and nut	124 to 150 N·m 12.7 to 15.2 kgf·m 91.5 to 110 lbf·ft
-------------------	-----------------------------	--

(1) Bolt and Nut

9Y1210982TRS0021US0



Cabin Assembly

1. Hook the cabin with nylon slings not to damage the cabin.
2. Dismount the cabin from the tractor body.
3. Support the cabin with a stand.

■ **NOTE**

- Lift and turn the cabin while making sure it does not catch on anything.

(When reassembling)

- Be sure to install the washer and mount rubbers, etc, in their original position.



9Y1210982TRS0022US0

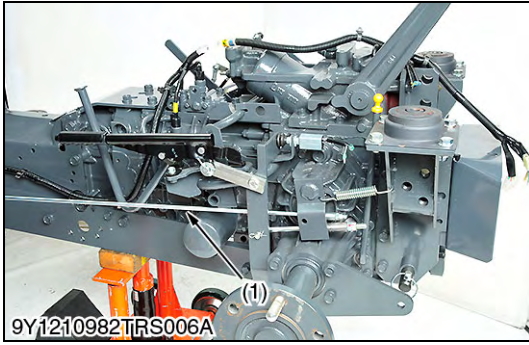

Brake Rods

1. Remove the both side brake rods.

(1) Brake Rod

9Y1210982TRS0023US0

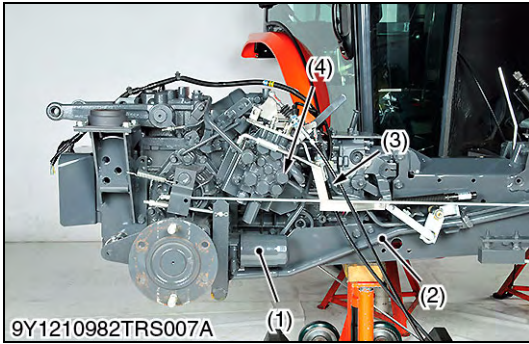

Hydraulic Pipes and Others

1. Remove the transmission oil filter cartridge (1).
2. Disconnect the suction pipe (2) and delivery pipe (3).
3. Disconnect the loader valve pipes (4).

(When reassembling)

- Do not damage the O-rings of front loader valve pipes and delivery pipes.

Tightening torque	Front loader valve pipe joint bolt	48 to 70 N·m 4.9 to 7.1 kgf·m 36 to 51 lbf·ft
-------------------	------------------------------------	---

(1) Transmission Oil Filter Cartridge
(2) Suction Pipe

(3) Delivery Pipe
(4) Loader Valve Pipe

9Y1210982TRS0024US0

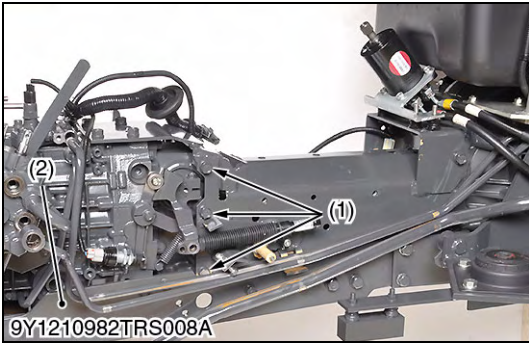

Main Frame, Sub Frame and Cabin Mount Rear Frame

1. Remove the main frame bolts (1).
2. Remove the both side sub frames (2).
3. Remove the Cabin mount rear frame (3).

(When reassembling)

Tightening torque	Sub frame mounting bolt (M12)	80 to 90 N·m 8.2 to 9.1 kgf·m 59 to 66 lbf·ft
	Sub frame mounting bolt (M14)	126 to 150 N·m 12.9 to 15.2 kgf·m 93.0 to 110 lbf·ft
	Sub frame mounting bolt (M10)	40 to 45 N·m 4.1 to 4.6 kgf·m 30 to 33 lbf·ft
	Cabin mount rear frame bolt	90 to 95 N·m 9.2 to 9.6 kgf·m 67 to 70 lbf·ft

- (1) Bolt
(2) Sub Frame

- (3) Cabin Mounting Rear Frame

9Y1210982TRS0025US0

(3) Separating Engine and Clutch Housing (CABIN)

- See page 1-S24.

9Y1210982TRS0026US0

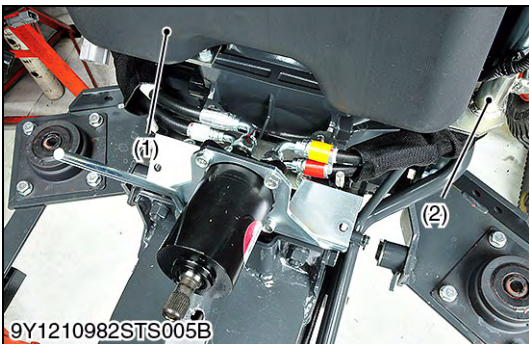

Fuel Tank

1. Remove the fuel tank (1) with pillar (2).

- (1) Fuel Tank

- (2) Pillar

9Y1210982TRS0116US0

(4) Separating Transmission from Tractor Body (ROPS)



ROPS, Seat, Fender and Cover

1. Disconnect the tail lamp connectors, hazard lamp connectors and trailer socket connectors.
2. Remove the seat (1).
3. Remove the grips.
4. Remove the fenders (2).
5. Remove the seat under cover (3) and cover (4).
6. Remove the ROPS (5).

- (1) Seat
(2) Fender
(3) Seat Under Cover

- (4) Cover
(5) ROPS

9Y1210982TRS0027US0

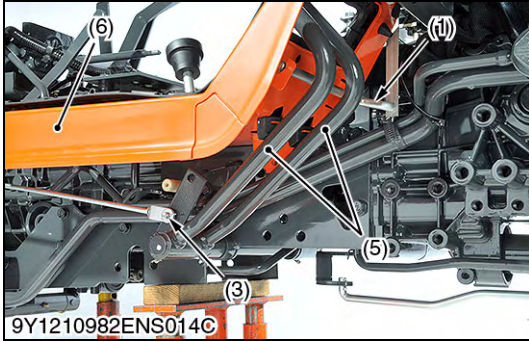

Step (Manual Transmission Model)

1. Disconnect the accelerator rod (1).
2. Remove the return spring (2).
3. Remove the pin (3) and disconnect brake rod (4) from brake pedal (5).
4. Remove the both side steps (6).

(When reassembling)

- Be sure to adjust the brake pedal free travel and parking brake lever travel.

- | | |
|---------------------|-----------------|
| (1) Accelerator Rod | (4) Brake Rod |
| (2) Return Spring | (5) Brake Pedal |
| (3) Pin | (6) Step |

9Y1210982TRS0117US0

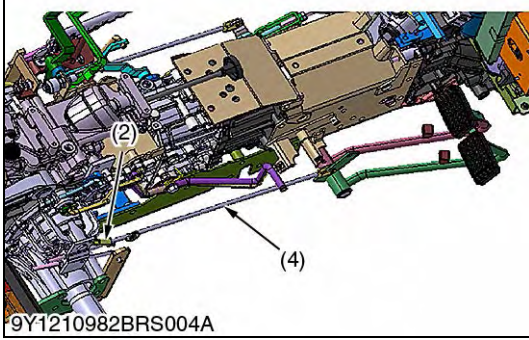

Step (HST Model)

1. Remove the HST pedal (1).
2. Remove the return spring (2).
3. Remove the pin (3) and disconnect brake rod (4) from brake pedal (5).
4. Disconnect lever (6) from brake pedal (5).
5. Remove the both side steps.

(When reassembling)

- Be sure to adjust the brake pedal free travel and parking brake lever travel.

- | | |
|-------------------|-----------------|
| (1) HST Pedal | (4) Brake Rod |
| (2) Return Spring | (5) Brake Pedal |
| (3) Pin | (6) Lever |

9Y1210982TRS0118US0

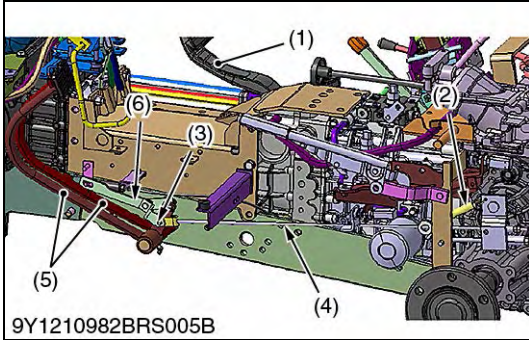

Main Frame and Sub Frame

1. Remove the main frame bolts (1).
2. Remove the both side sub frames (2).

(When reassembling)

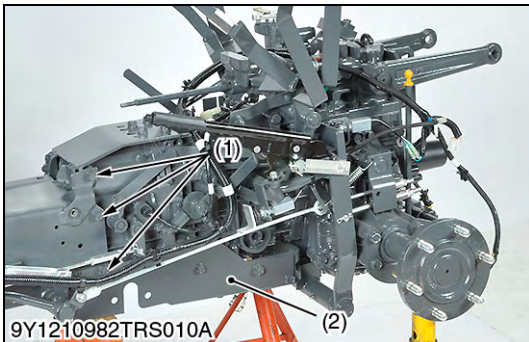

Tightening torque	Sub frame mounting bolt (M10)	40 to 46 N·m 4.1 to 4.6 kgf·m 30 to 33 lbf·ft
	Sub frame mounting bolt (M12)	80 to 90 N·m 8.2 to 9.1 kgf·m 59 to 66 lbf·ft
	Sub frame mounting nut (M14)	100 to 126 N·m 10.2 to 13.0 kgf·m 73.8 to 94.4 lbf·ft
	Sub frame mounting bolt (M14)	126 to 150 N·m 12.9 to 15.2 kgf·m 93.0 to 110 lbf·ft

- | | |
|----------|---------------|
| (1) Bolt | (2) Sub Frame |
|----------|---------------|

9Y1210982TRS0119US0

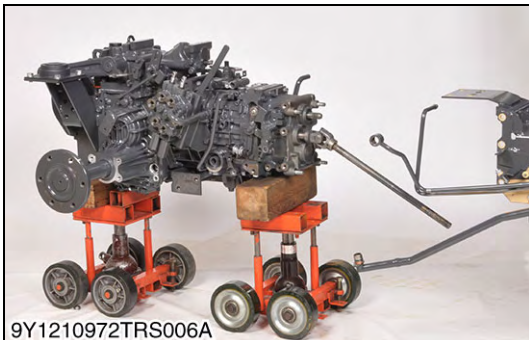

(5) Separating Engine and Clutch Housing (ROPS)

- See page 1-S27.

9Y1210982TRS0120US0

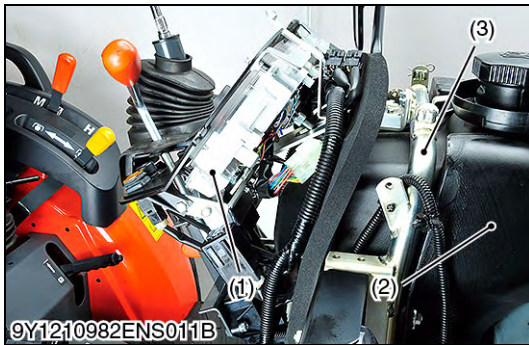

Meter Panel, Wiring Harness and Fuel Tank

1. Remove the meter panel (1).
2. Disconnect the wiring harness.
3. Remove the fuel tank (2) with pillar (3).

- (1) Meter Panel
(2) Fuel Tank

- (3) Pillar

9Y1210982TRS0121US0

[3] DISASSEMBLING AND ASSEMBLING

(1) Front Case

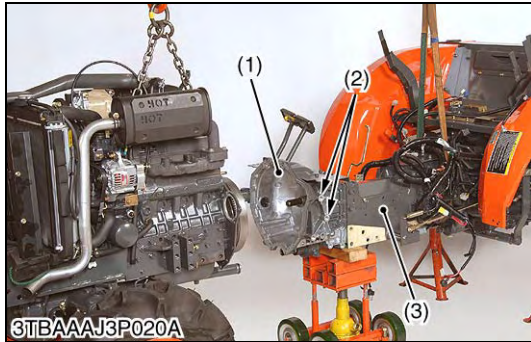

Front Case Assembly

1. Support the engine securely.
2. Remove the front case mounting bolts (1).
3. Remove the front case (1) from the frame (3).

(When reassembling)

- Apply liquid gasket (Three Bond 1206D or equivalent) to the joint face of the engine and the front case.

Tightening torque	Front case mounting bolt for aluminum (M10)	39.3 to 44.1 N·m 4.0 to 4.5 kgf·m 29.0 to 32.5 lbf·ft
-------------------	---	---

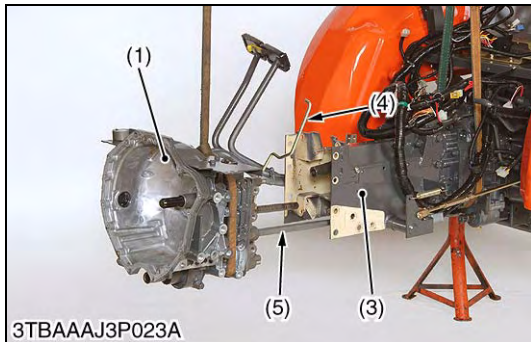

- | | |
|----------------|---------------------|
| (1) Front Case | (4) Bi-Speed Rod 1 |
| (2) Bolt | (5) Delivery Pipe |
| (3) Frame | (6) Propeller Shaft |

9Y1210982TRS0041US0

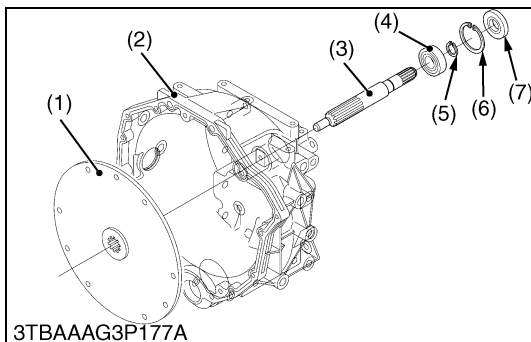
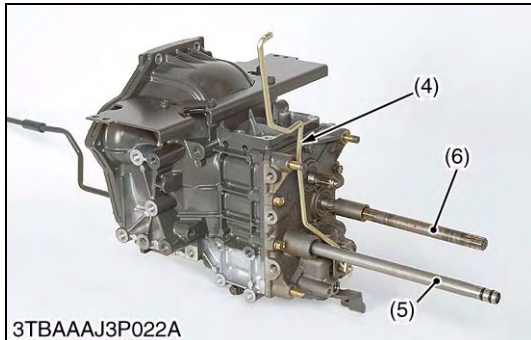
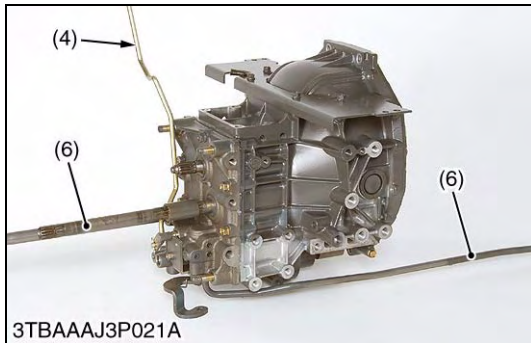

Clutch Shaft and Ball Bearing

1. Remove the oil seal (7).
2. Remove the cir-clip (6).
3. Remove the clutch shaft (3) from the front case (2).

- | | |
|------------------|-----------------------|
| (1) Steel Plate | (5) External Cir-clip |
| (2) Front Case | (6) Internal Cir-clip |
| (3) Clutch Shaft | (7) Oil Seal |
| (4) Ball Bearing | |

9Y1210982TRS0042US0

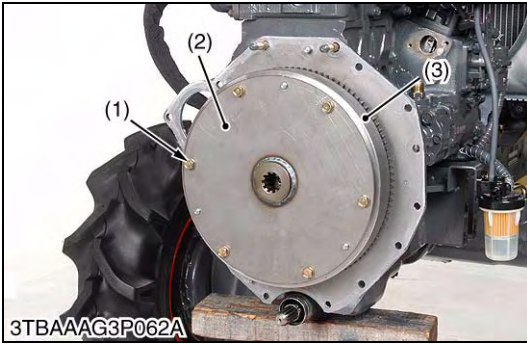

Steel Plate

1. Remove the steel plate mounting bolts (1).
2. Remove the steel plate (2) from the flywheel.
 - Apply liquid gasket (Three Bond 1206D or equivalent) to the joint face of the engine and the front case.

Tightening torque	Steel plate mounting bolt (M8)	23.6 to 27.4 N·m 2.4 to 2.8 kgf·m 17.4 to 20.2 lbf·ft
-------------------	--------------------------------	---

- (1) Steel Plate Mounting Bolt (3) Flywheel
(2) Steel Plate

9Y1210982TRS0043US0

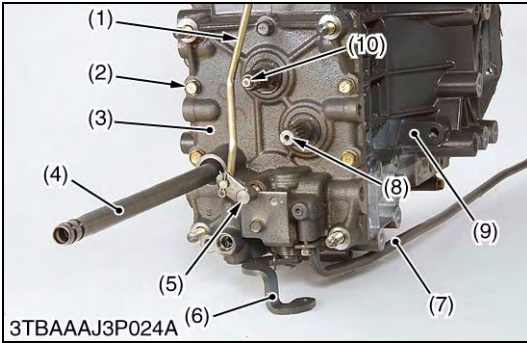

Bi-Speed Turn ON-OFF Valve and Front Case Rear Cover

1. Remove the Bi-Speed Turn rod 1 (1), the Bi-Speed Turn ON-OFF valve (5) and the Bi-Speed Turn Valve (6).
2. Remove the connecting pipe (4).
3. Remove the front case rear cover mounting bolts (2) and the front case rear cover (3).

(When assembling)

- Check the oil seals and the O-ring for damage.

- (1) Bi-Speed Turn Rod 1 (8) Front Wheel Drive Shaft 1
(2) Bolt (9) Front Case
(3) Front Case Rear Cover (10) Clutch Shaft
(4) Connecting Pipe (11) Plug
(5) Bi-Speed Turn ON-OFF Valve (12) Spring
(6) Bi-Speed Turn Valve (13) Oil Seal
(7) Delivery Pipe (14) Oil Seal

9Y1210982TRS0044US0

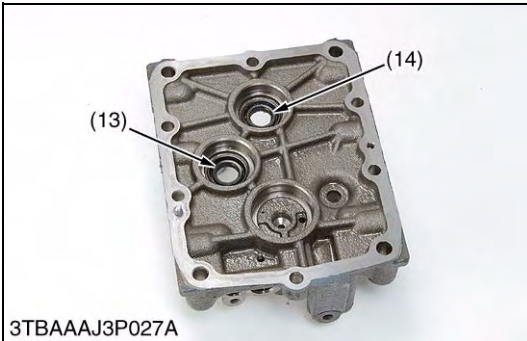
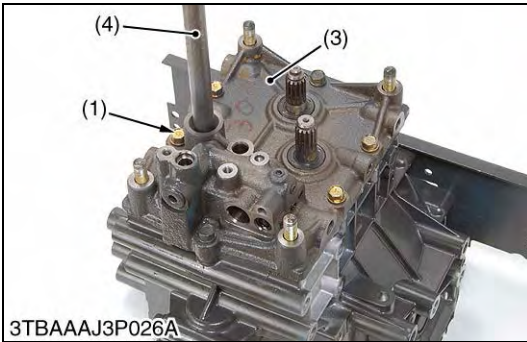
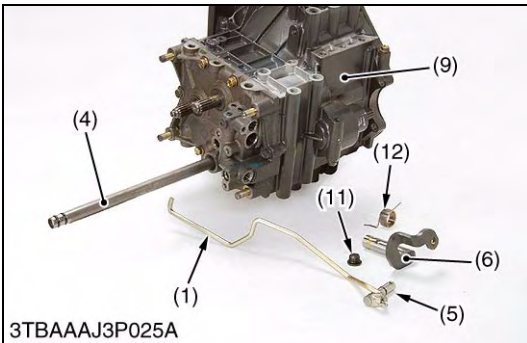

Bi-Speed Turn Clutch Assembly and Front Wheel Drive Shaft 1

1. Remove the clutch shaft 1), the front wheel drive shaft 1 (2) and Bi-Speed Turn clutch shaft (3) from the front case (4).
2. Remove the internal cir-clip (7).
3. Remove the front wheel drive shaft 3 (5) with the bearing holder (6).

- | | |
|--------------------------------|-------------------------------|
| (1) Clutch Shaft | (5) Front Wheel Drive Shaft 3 |
| (2) Front Wheel Drive Shaft 1 | (6) Bearing Holder |
| (3) Bi-Speed Turn Clutch Shaft | (7) Internal Cir-clip |
| (4) Front Case | |

9Y1210982TRS0045US0

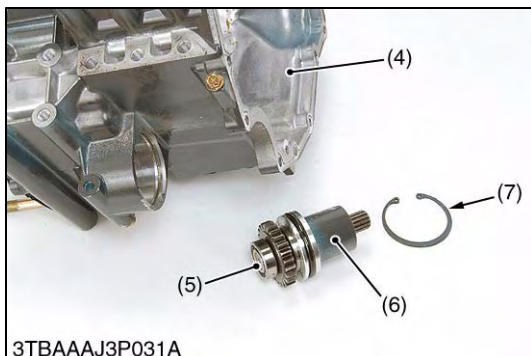
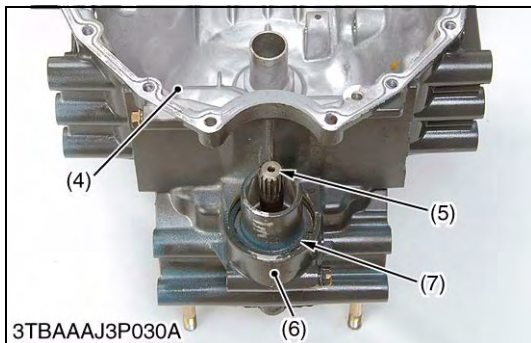
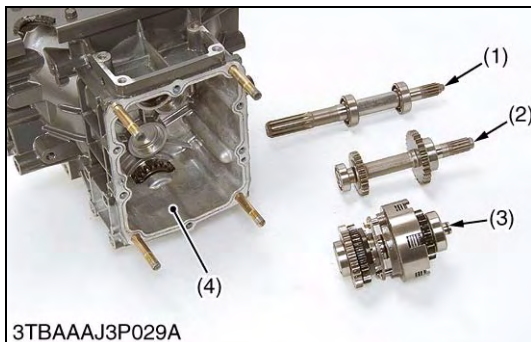
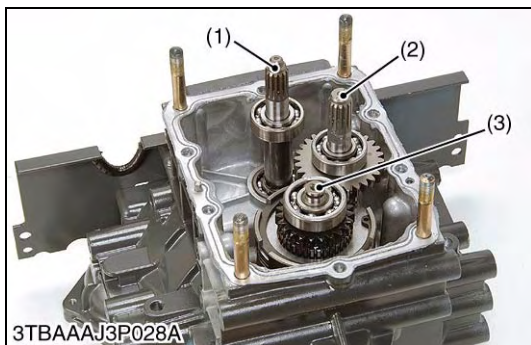

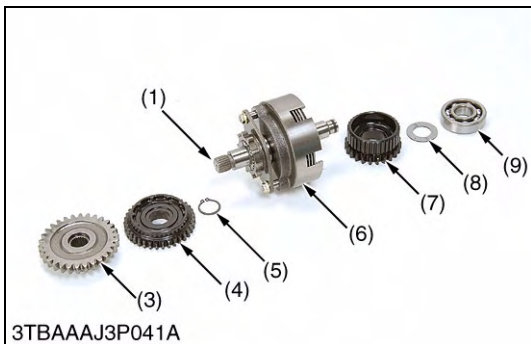
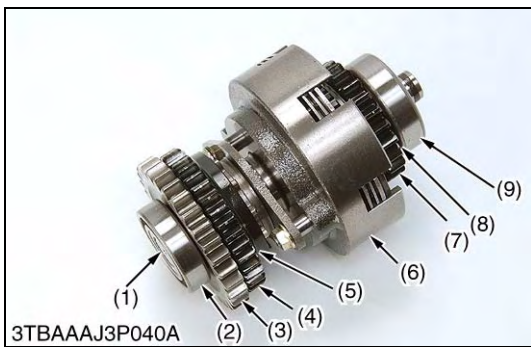

Disassembling Bi-Speed Turn Clutch Assembly 1

1. Remove the bearings (2).
2. Remove the 30T gear (3), the 35T gear (4) and the cir-clip (5).
3. Remove the bearing (9).
4. Remove the thrust collar (8) and the 23T gear (7).

(When assembling)

- Check the seal ring for damage.

- | | |
|--|-------------------------------|
| (1) Bi-Speed Turn Clutch Shaft (Front Wheel Drive Shaft 2) | (5) Cir-clip |
| (2) Bearing | (6) Bi-Speed Turn Clutch Case |
| (3) 30T Gear | (7) 23T Gear |
| (4) 35T Gear | (8) Thrust Collar |
| | (9) Bearing |

9Y1210982TRS0046US0

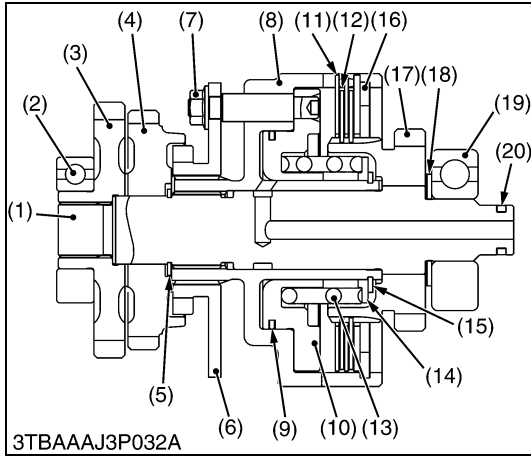

Disassembling Bi-Speed Turn Clutch Assembly 2

1. Remove the Bi-Speed Turn clutch shaft (1).
2. Loosen and remove the flange nuts (7).
3. Remove the shifter (6).
4. Remove the cir-clip with the special tools (21), (22).
5. Remove the internal cir-clip (16).
6. Remove the clutch disks (12) and the plates (11).

(When assembling)

- Check the seal ring for damage.
- Tighten the flange nuts to the specified tightening torque.
- After tighten the flange nut, punch the nut at the two portions as shown in the picture.

Tightening torque	Bi-Speed Turn clutch shifter mounting flange nut (M18)	9.8 to 11.8 N·m 1.0 to 1.2 kgf·m 7.3 to 8.6 lbf·ft
-------------------	--	--

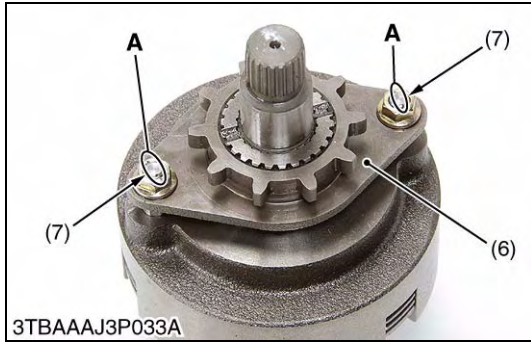

- | | |
|--|---------------------------|
| (1) Bi-Speed Turn Clutch Shaft (Front Wheel Drive Shaft 2) | (12) Clutch Disk |
| (2) Bearing | (13) Piston Return Spring |
| (3) 30T Gear | (14) Collar |
| (4) 35T Gear | (15) Cir-clip |
| (5) Cir-clip | (16) Internal Cir-clip |
| (6) Shifter | (17) 23T Gear |
| (7) Flange Nut | (18) Thrust Collar |
| (8) Bi-Speed Turn Clutch Case | (19) Bearing |
| (9) D-ring | (20) Seal Ring |
| (10) Clutch Piston | |
| (11) Clutch Plate | |
- A: Punch**

9Y1210982TRS0047US0

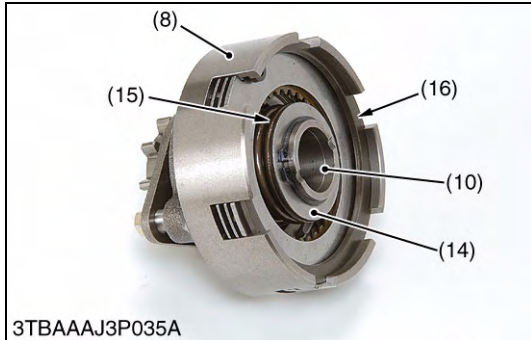
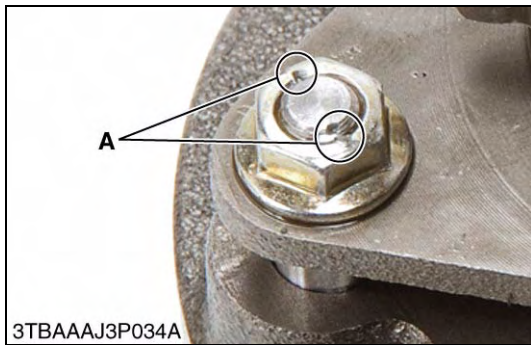

(2) Main Gear Shift Section

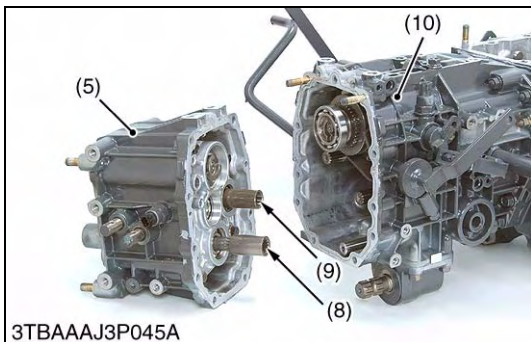
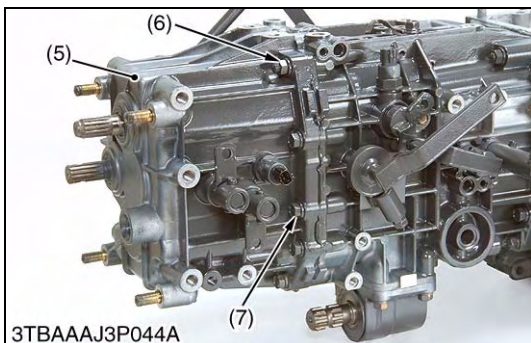
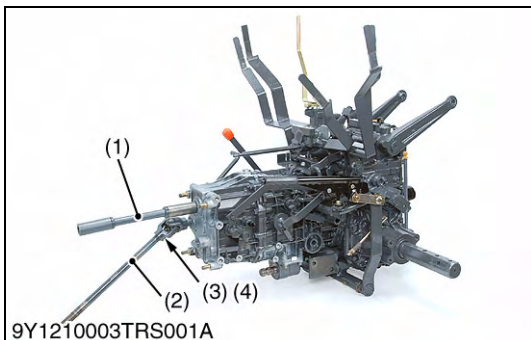
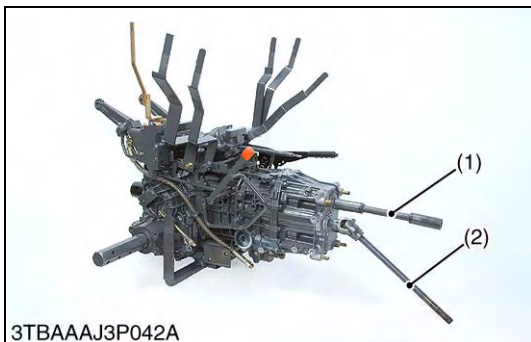

Separating Main Gear Shift Section Assembly

1. Remove the propeller shaft (1).
2. Remove the spring pins (3), (4).
3. Remove the main gear shift section mounting bolts (7) and the nuts (6).
4. Separate the main gear shift section case assembly (5) from the transmission case.

(When assembling)

- Apply the liquid gasket (Three Bond 1206D or its equivalent).
- Align the coupling spline between the shuttle shaft and the Hi-Lo gear shaft. Align the coupling spline between the front wheel drive shafts.

Tightening torque	Main gear shift section mounting bolt (M10)	39.3 to 44.1 N·m 4.0 to 4.5 kgf·m 29.0 to 32.5 lbf·ft
	Main gear shift section mounting nut (M10)	39.3 to 44.1 N·m 4.0 to 4.5 kgf·m 29.0 to 32.5 lbf·ft

- | | |
|---|---|
| (1) Propeller Shaft | (7) Bolt |
| (2) Drive Shaft | (8) Couple Ring (Connecting for 4WD Shaft) |
| (3) Spring Pin | (9) Couple Ring (Connecting for Hi-Lo Gear Shaft) |
| (4) Spring Pin | (10) Transmission Case |
| (5) Main Gear Shift Section Case Assembly | |
| (6) Nut | |

9Y1210982TRS0049US0

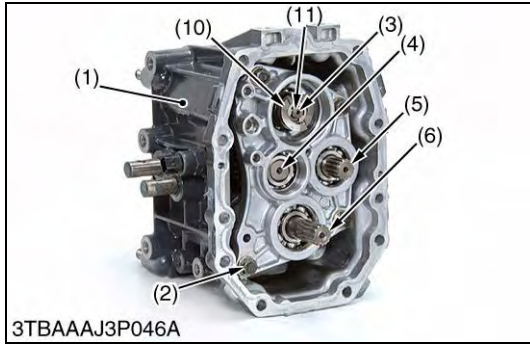

Removing Mechanical PTO Clutch Cam and Bearing Holder

1. Remove the cir-clip (11).
2. Remove the one way clutch cam (10), the one way clutch spring (9) and the collar (8).
3. Remove the bearing holder mounting bolts (2).
4. Remove the bearing holder (7).

(When assembling)

- Install the spacer (12) to the bearing.

Tightening torque	Main gear shift bearing holder mounting bolt (M8)	17.7 to 20.5 N·m 1.8 to 2.1 kgf·m 13.1 to 15.1 lbf·ft
-------------------	---	---

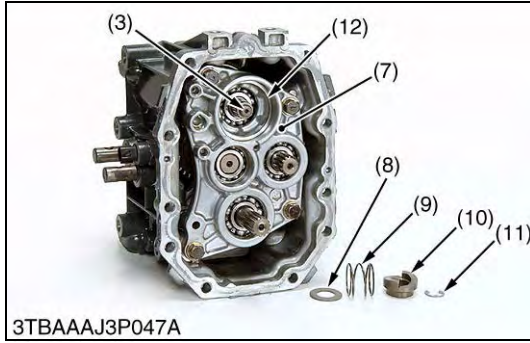

- | | |
|---|--------------------------------|
| (1) Main Gear Shift (Section) Case | (7) Bearing Holder |
| (2) Bolt | (8) Collar (1.6 mm, 0.063 in.) |
| (3) Shift Shaft 1 | (9) One Way Clutch Spring |
| (4) Shift Shaft 2 | (10) One Way Clutch Cam |
| (5) Front Wheel Drive Shaft (Reverse Shaft) | (11) Cir-clip |
| (6) Shuttle Shaft | (12) Spacer |

9Y1210982TRS0050US0

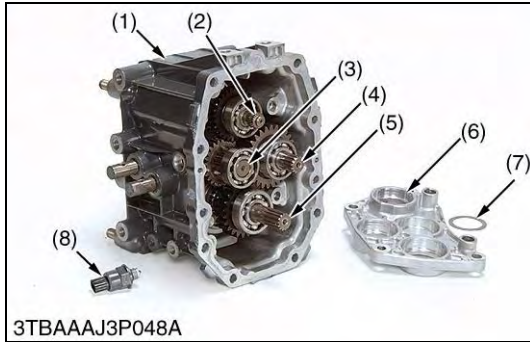

Removing Main Gear Shift Shafts

1. Remove the shim (7) with the bearing holder (6).
2. Remove the shuttle switch (8).
3. Remove the shuttle shaft (5), the shift shaft 2 (3), the front wheel drive shaft (4) and the shift shaft 1 (2) temporarily.

(When assembling)

- Remove the bearing (10) from the front wheel drive shaft (4).
- Install the bearing (10) to the main gear shift (section) case (1).
- Install the shuttle shifter (9) and the shuttle shaft (5) to the main gear shift (section) case (1).
- Install the three shafts, the shift shaft 1 (2), the shift shaft 2 (3) and the shuttle shaft (5) to the main gear shift (section) case (1) and install the front wheel drive shaft to the bearing simultaneously shaking all shafts (2), (3), (4), (5) slowly.
- Check the four shafts (2), (3), (4), (5) to rotate smoothly.
- Install the shim (7) to the bearing hole for the shuttle shaft.

- | | |
|---|---------------------|
| (1) Main Gear Shift (Section) Case | (6) Bearing Holder |
| (2) Shift Shaft 1 | (7) Shim |
| (3) Shift Shaft 2 | (8) Shuttle Switch |
| (4) Front Wheel Drive Shaft (Reverse Shaft) | (9) Shuttle Shifter |
| (5) Shuttle Shaft | (10) Bearing |

9Y1210982TRS0051US0

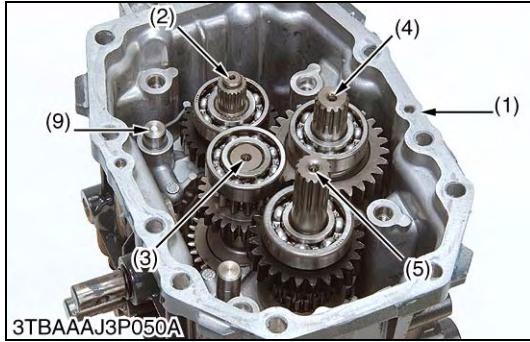
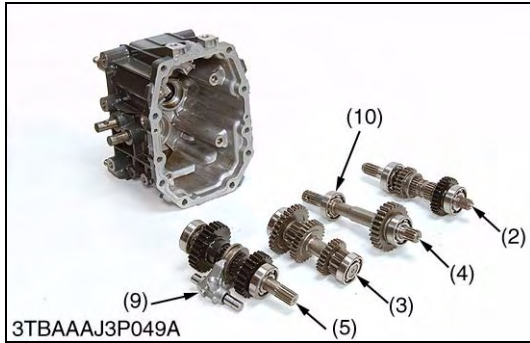

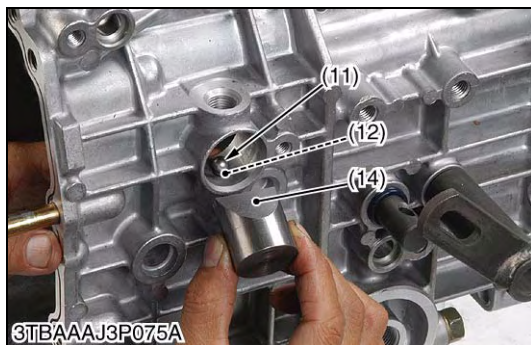
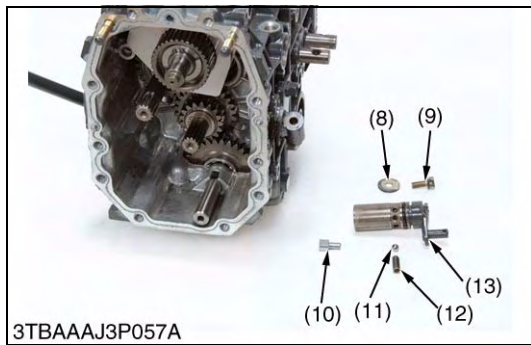
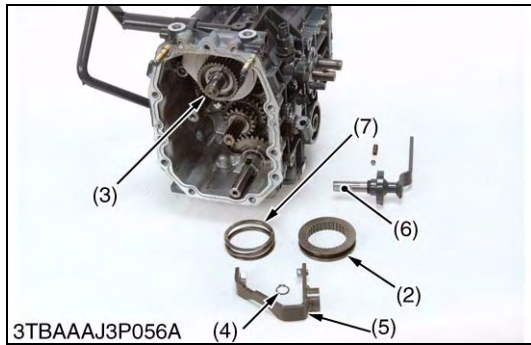
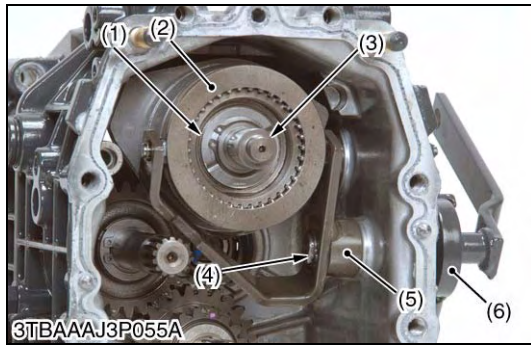

Removing PTO ON-OFF Shift Fork and PTO Shift Arm

1. Remove the cir-clip (1) from the PTO clutch shaft (3).
2. Remove the cir-clip (4) the PTO ON-OFF arm shaft (6).
3. Remove the shifter (2) and the PTO clutch spring (7).
4. Remove the bolt (9) and the washer (8) from the transmission case.
5. Remove the PTO shift arm (13).

(When reassembling)

- Install the PTO cotter (10) to the groove of the PTO shifter securely.
- Install the ball (11) and the spring (12) to the transmission case using the special ball guide (14).

- | | |
|---------------------------|--------------------|
| (1) Cir-clip | (8) Washer |
| (2) Shifter | (9) Bolt |
| (3) PTO Clutch Shaft | (10) PTO Cotter |
| (4) Cir-clip | (11) Ball |
| (5) PTO ON-OFF Shift Fork | (12) Spring |
| (6) PTO ON-OFF Arm Shaft | (13) PTO Shift Arm |
| (7) Clutch Spring | (14) Ball Guide |

9Y1210982TRS0054US0

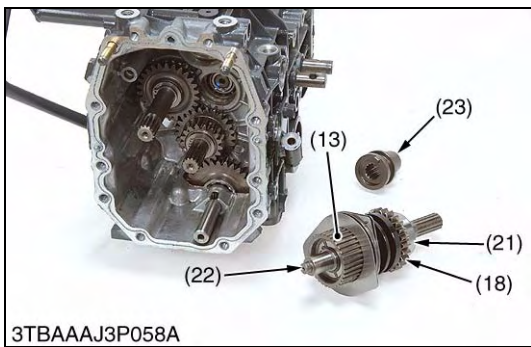

3TBAAAJ3P058A

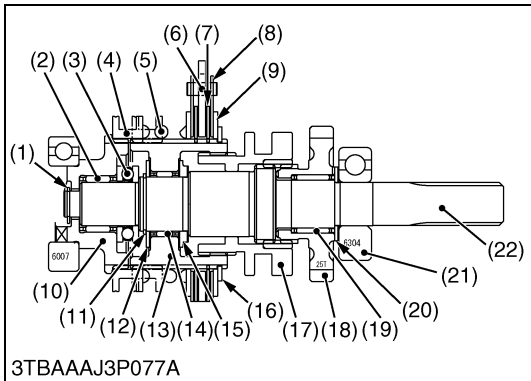

3TBAAAJ3P077A

Removing and Disassembling Mechanical PTO Clutch Assembly

1. Remove the rear PTO shifter (23) from the PTO clutch shaft (22).
2. Disassemble the mechanical PTO clutch assembly.

(When reassembling)

- Check the mechanical PTO clutch assembly parts the damage and wear, replace it.

- | | |
|---------------------------------|----------------------------|
| (1) Cir-clip | (13) PTO Brake Spline Boss |
| (2) Needle Bearing | (14) Needle Bearing |
| (3) Thrust Ball Bearing | (15) Thrust Collar |
| (4) Shifter (PTO ON/OFF) | (16) Cir-clip |
| (5) Clutch Spring | (17) PTO Shifter |
| (6) Brake Plate | (18) 25T Mid PTO Gear |
| (7) Brake Plate 3 | (19) Needle Bearing |
| (8) Brake Disk | (20) Collar |
| (9) Brake Plate 1 | (21) Ball Bearing |
| (10) One-way Clutch Spline Boss | (22) PTO Clutch Shaft |
| (11) Cir-clip | (23) Rear PTO Shifter |
| (12) Thrust Collar | |

9Y1210982TRS0055US0

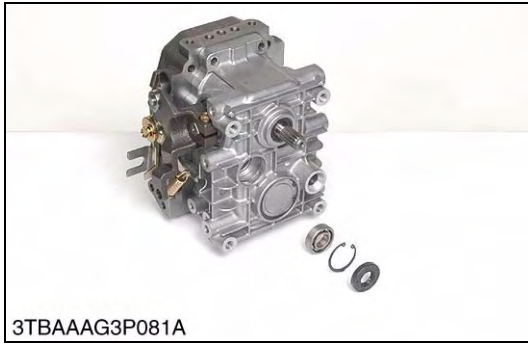

3TBAAAG3P081A

Plate Push Rod, Neutral Arm and Neutral Holder

1. Remove the plate push rod (1).
2. Remove the spring (4).
3. Remove the neutral arm mounting bolt.
4. Loosen the bolt of the neutral holder (3).
5. Remove the neutral holder (3).

- | | |
|--------------------|--------------------|
| (1) Plate Push Rod | (3) Neutral Holder |
| (2) Neutral Arm | (4) Spring |

9Y1210982TRS0058US0

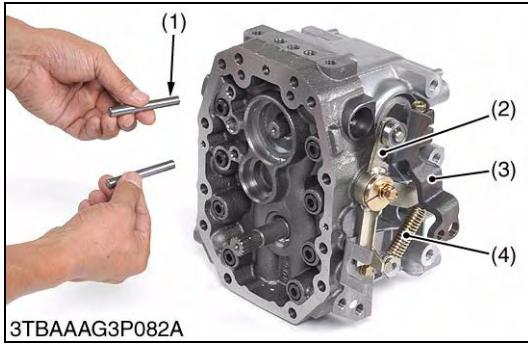

3TBAAAG3P082A

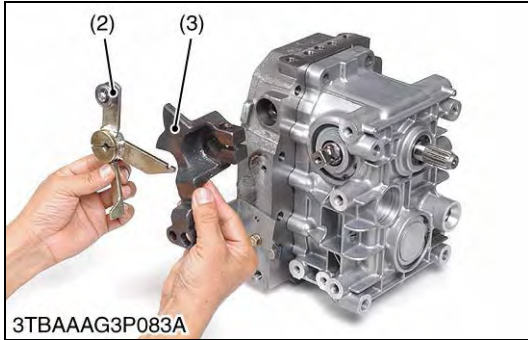

3TBAAAG3P083A

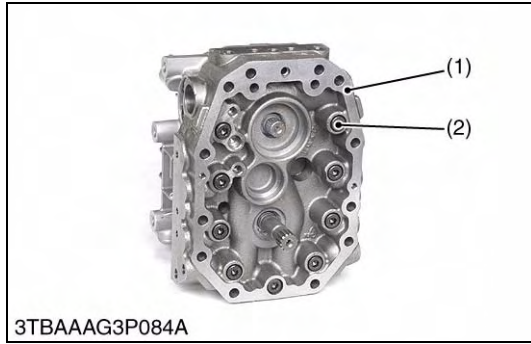

Center Section 1

1. Remove the center section mounting hex. bolts (2).
2. Separate the HST housing (3) from the center section (1).

(When reassembling)

- Use a new gasket.
- Install the poppet to the center section (1). Don't drop the spring (5).
- Check the knock pin.
- Hold the gasket with the hex. bolts (2) not to drop the gasket (4).

Tightening torque	Center section mounting hex. bolt for aluminum (M10)	39.3 to 44.1 N·m 4.0 to 4.5 kgf·m 29.0 to 32.5 lbf·ft
-------------------	--	---

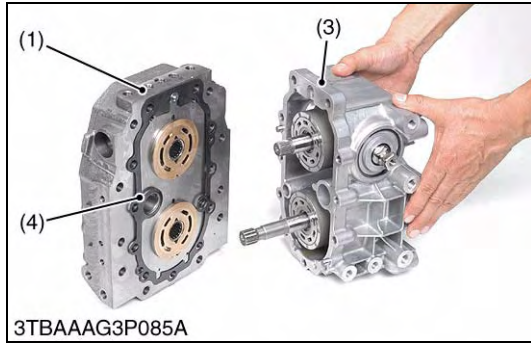

- | | |
|--------------------|---------------|
| (1) Center Section | (5) Spring |
| (2) Hex. Bolt | (6) Poppet |
| (3) HST Housing | (7) Knock Pin |
| (4) Gasket | |

9Y1210982TRS0059US0

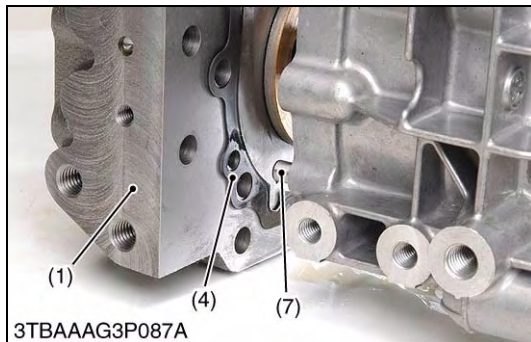
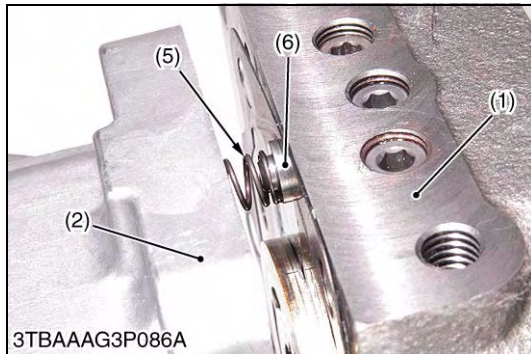

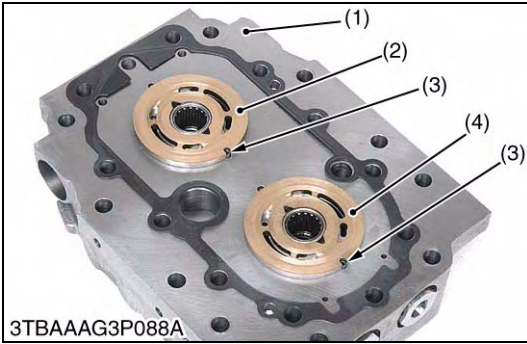

Valve Plates

1. Pushing the valve plate (2) against the anchor pin (3), lift the valve plate (2) to remove.
2. Remove the valve plate (2).
3. Remove the valve plate (4).

(When reassembling)

- Install the groove (5) the valve plates (2), (4) to the anchor pins (3) securely.

- | | |
|------------------------------|-------------------------------|
| (1) Center Section | (4) Valve Plate (Motor Shaft) |
| (2) Valve Plate (Pump Shaft) | (5) Groove |
| (3) Anchor Pin | |

9Y1210982TRS0060US0

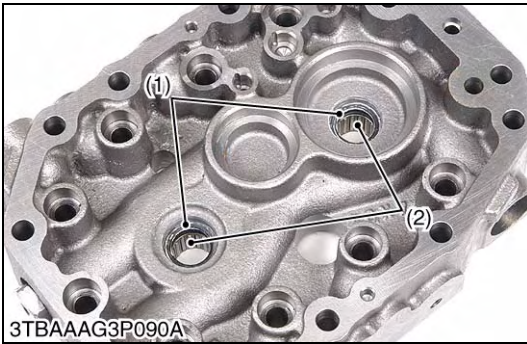

Oil Seals and Needle Bearings

1. Remove the needle bearing (2).
2. Remove the oil seals (1).

(When reassembling)

- After checking or changing the oil seals, apply the bearing with hydrostatic transmission oil and the oil seal with grease.

- | | |
|--------------|--------------------|
| (1) Oil Seal | (2) Needle Bearing |
|--------------|--------------------|

9Y1210982TRS0061US0

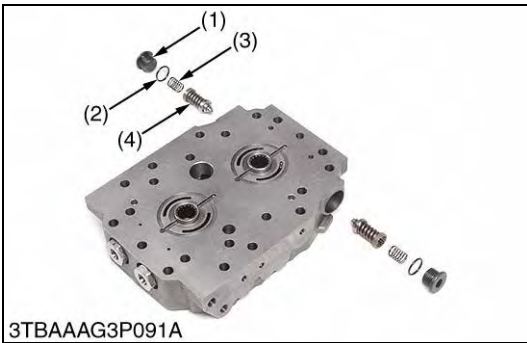

Check and High Pressure Relief Valve

1. Remove the valve plug (1) with a hex. wrench.
2. Remove the spring (3) and the valve (4).

(When reassembling)

Tightening torque	Check and high pressure relief valve plug	118 to 147 N·m 12.0 to 15.0 kgf·m 86.8 to 108.5 lbf·ft
-------------------	---	--

- | | |
|----------------|------------|
| (1) Valve Plug | (3) Spring |
| (2) O-ring | (4) Valve |

9Y1210982TRS0062US0

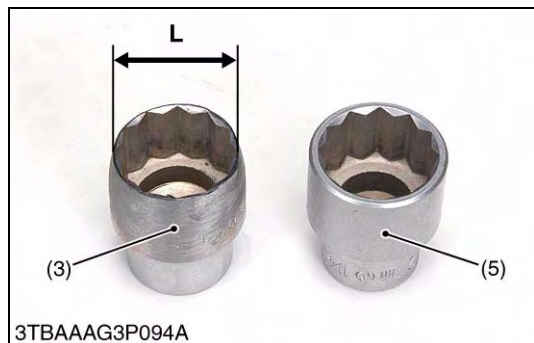
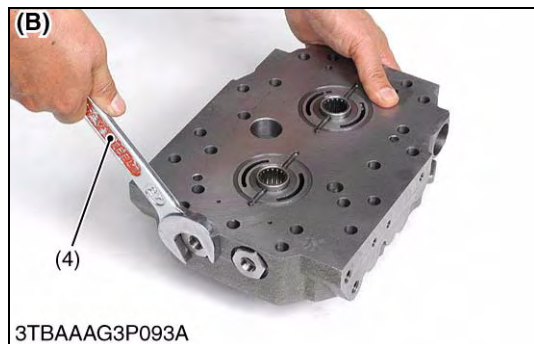
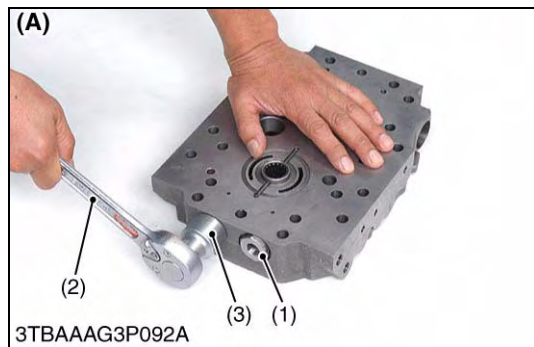

Removing Neutral Valve

1. Remove the neutral valve (1) with the ratchet handle and the thin socket (27 mm (1.06 in.)).

(When reassembling)

Tightening torque	Neutral valve body	58.5 to 68.6 N·m 6.0 to 7.0 kgf·m 43.4 to 50.6 lbf·ft
-------------------	--------------------	---

- (1) Neutral Valve
- (2) Ratchet Handle
- (3) Thin Socket (27 mm (1.06 in.))
- (4) Spanner (27 mm (1.06 in.))
- (5) Common Socket (27 mm (1.06 in.))

- (A) Using Correct Tools**
- (B) Using Wrong Tools**
- L: Outside Diameter (Approx. 27 mm (1.06 in.))**

9Y1210982TRS0063US0

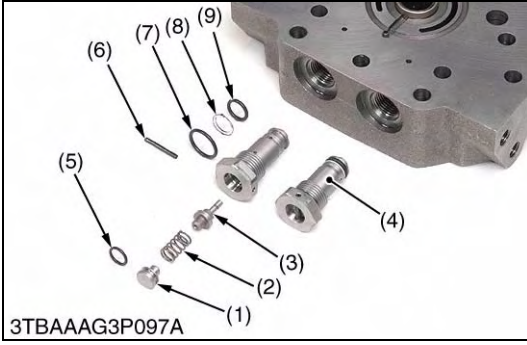
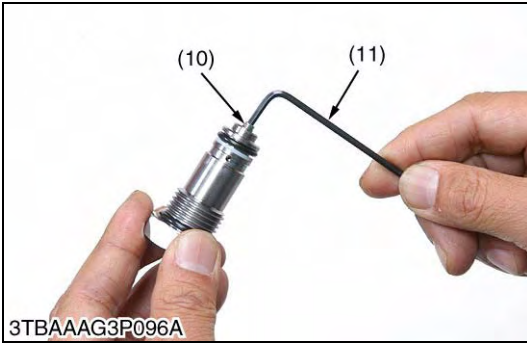
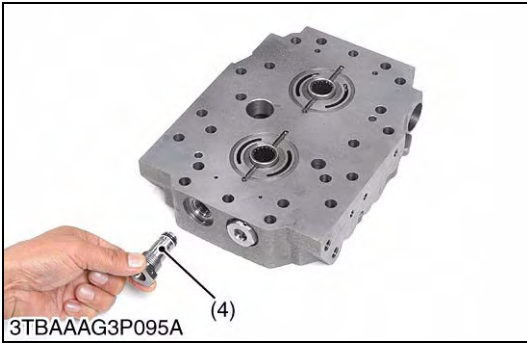

Neutral Valve

1. Remove the neutral valve body (4).
2. Remove the pin (6) from the neutral valve body (4).
3. Remove the plug (10) with 2.5 mm hex. wrench (11).
4. Push the neutral valve (3) with 2.5 mm hex. wrench (11) not to damage it.
5. Remove the inner parts from the neutral valve body (4).

(When reassembling)

Tightening torque	Neutral valve body	58.5 to 68.6 N·m 6.0 to 7.0 kgf·m 43.4 to 50.6 lbf·ft
-------------------	--------------------	---

- | | |
|------------------------|-------------------------|
| (1) Plug | (7) O-ring |
| (2) Spring | (8) Back-up Ring |
| (3) Neutral Valve | (9) O-ring |
| (4) Neutral Valve Body | (10) Plug |
| (5) O-ring | (11) 2.5 mm Hex. Wrench |
| (6) Pin | |

9Y1210982TRS0064US0

HST Housing Case Cylinder Blocks

1. Remove the cylinder blocks (1) and (4) from the pump shaft (2) and the motor shaft (3).
2. Remove the cir-clip (5) and spring (6) from the cylinder block.

(When reassembling)

- Install the poppet (8) to the center section, not to drop it.
- Install the spring (7) to the HST housing side.

- | | |
|----------------------------|--------------|
| (1) Cylinder Block (Pump) | (5) Cir-clip |
| (2) Pump Shaft | (6) Spring |
| (3) Motor Shaft | (7) Spring |
| (4) Cylinder Block (Motor) | (8) Poppet |

9Y1210982TRS0065US0

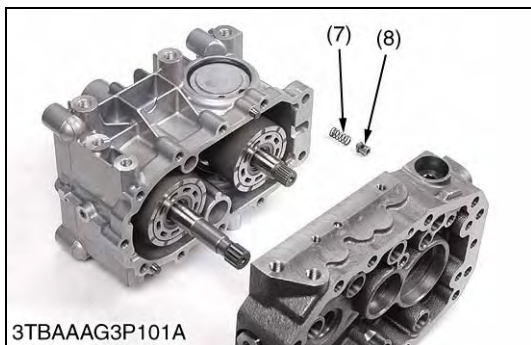
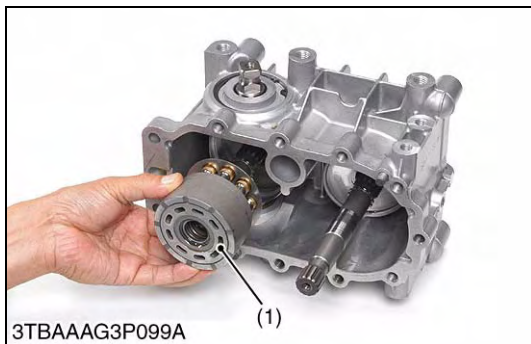
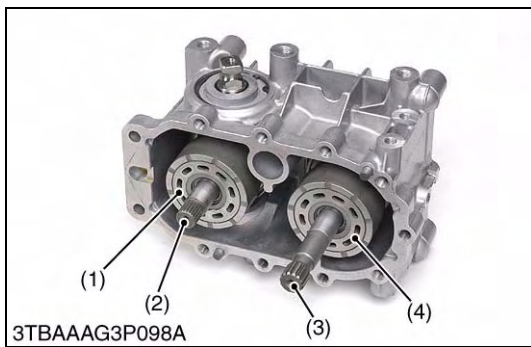

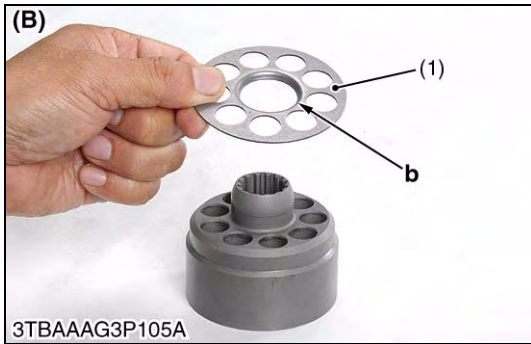
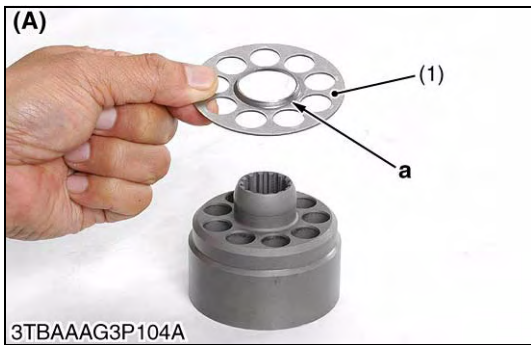
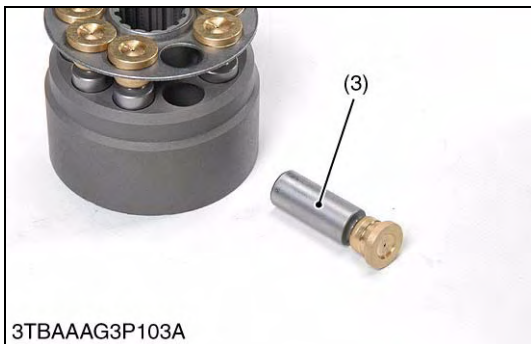

Piston and Retainer Plate

1. Remove the pistons (2) with the retainer plates (1).

(When reassembling)

- Install the piston to its original position of the cylinder block.
- Check the direction of the retainer plate (1) as shown in the picture.
- If the direction of the retainer plate is wrong, HST will not be operated properly.

- (1) Retainer Plate
- (2) Piston Slipper
- (3) Piston

- (A) Retainer Plate Correct Direction**
- (B) Retainer Plate Wrong Direction**
- a: Correct Direction**
- b: Wrong Direction**

9Y1210982TRS0066US0

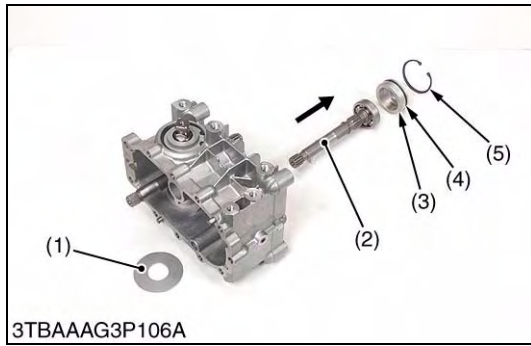

Motor Shaft

1. Remove the internal cir-clip (5) from the HST housing.
2. Remove the cover with an O-ring.
3. Remove the motor shaft (2) with the ball bearing (6) from the HST housing.
4. Remove the external cir-clip (7) from the motor shaft (2).
5. Remove the ball bearing (6) from the motor shaft (2).

- | | |
|-------------------|-----------------------|
| (1) Thrust Collar | (5) Internal Cir-clip |
| (2) Motor Shaft | (6) Ball Bearing |
| (3) Cover | (7) External Cir-clip |
| (4) O-ring | |

9Y1210982TRS0067US0

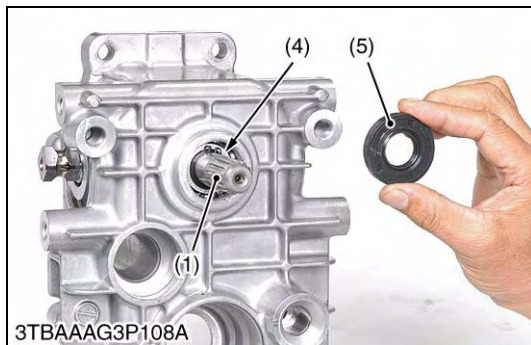
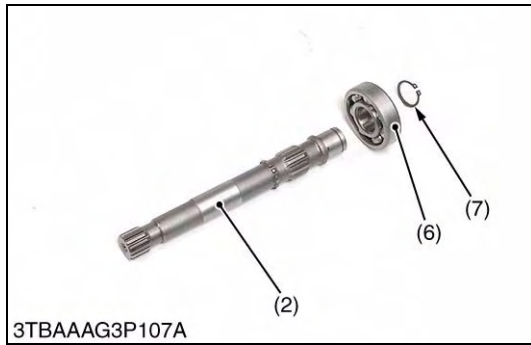

Pump Shaft

1. Remove the internal cir-clip (6) from the HST housing.
2. Remove the oil seal (5) from the HST housing.
3. Remove the external cir-clip (4) from the pump shaft (1).
4. Remove the internal cir-clip (2) from the HST housing.
5. Remove the pump shaft (1) to the cylinder block side.

(When reassembling)

- Replace the used oil seal with a new one.

- | | |
|-----------------------|-----------------------|
| (1) Pump Shaft | (4) External Cir-clip |
| (2) Internal Cir-clip | (5) Oil Seal |
| (3) Ball Bearing | (6) Internal Cir-clip |

9Y1210982TRS0068US0

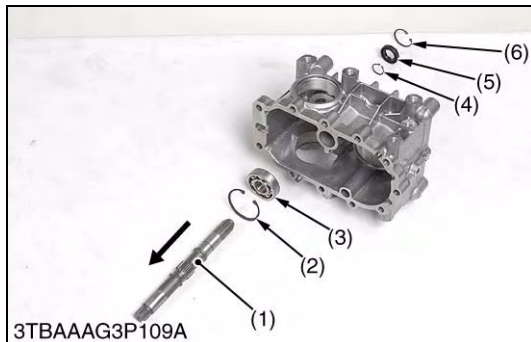

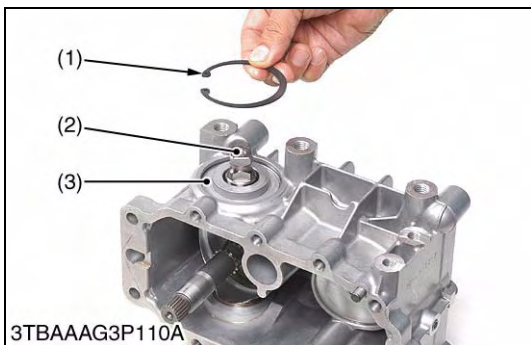

3TBAAAG3P110A

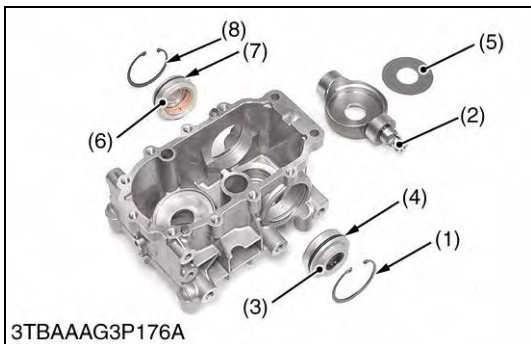

3TBAAAG3P176A

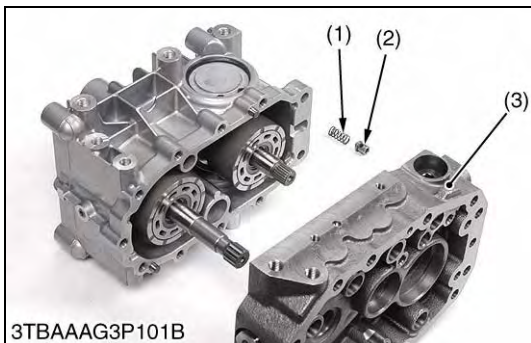

3TBAAAG3P101B

Trunnion Shaft

1. Remove the internal cir-clip (1) from the HST housing.
2. Remove the internal cir-clip (8) from the HST housing.
3. Strike out the trunnion shaft (2) slightly with a plastic hammer to the left side not to damage the o-rings (7), (4).
4. Remove the cover (3) with o-ring.
5. Remove the thrust collar using air blower.

(When reassembling)

- Check the O-rings for damage.

- | | |
|-----------------------|-----------------------|
| (1) Internal Cir-clip | (5) Thrust Collar |
| (2) Trunnion Shaft | (6) Cover (L.H.) |
| (3) Cover (R.H.) | (7) O-ring |
| (4) O-ring | (8) Internal Cir-clip |

9Y1210982TRS0069US0

Charge Relief Valve

1. Check the spring (1) for breakage and wear.
2. If it is unusual, replace it.

- | | |
|------------|--------------------|
| (1) Spring | (3) Center Section |
| (2) Poppet | |

9Y1210982TRS0070US0

(5) PTO Clutch Case (HST Model)

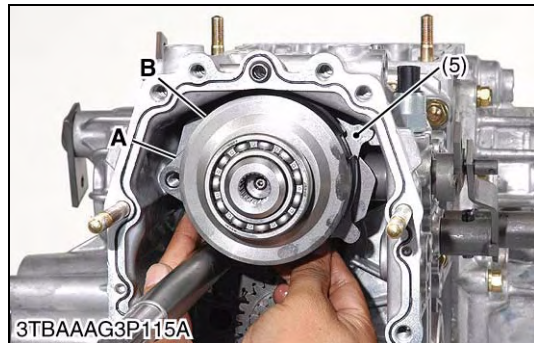
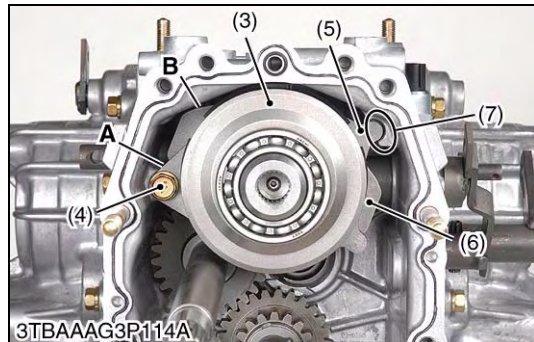
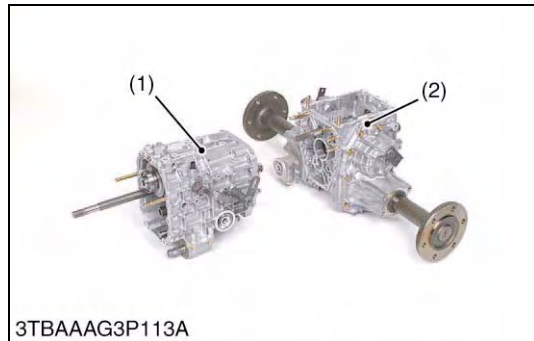
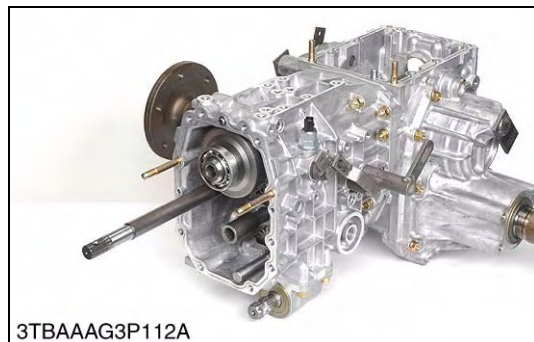

Separating Differential case and PTO Clutch Case

1. Remove the transmission case mounting bolts.
2. Separate the transmission case (1) from the differential case (2).
3. Remove the PTO brake plate 4 mounting bolt (4).

(When reassembling)

- Install the PTO brake plate 4 (5) to the transmission case groove (7) securely as shown in the picture.
- Place the PTO brake plate 2 (6) between **A** and **B**.

Tightening torque	Transmission case mounting bolt (M10) and nut	39.3 to 44.1 N·m 4.0 to 4.5 kgf·m 29.0 to 32.5 lbf·ft
	Hydraulic cylinder mounting bolt (M10) and nut	39.3 to 44.1 N·m 4.0 to 4.5 kgf·m 29.0 to 32.5 lbf·ft

- (1) Transmission Case
 - (2) Differential Case
 - (3) PTO Clutch Case
 - (4) PTO Brake Plate 4 Mounting Bolt
 - (5) PTO Brake Plate 4
 - (6) PTO Brake Plate 2
 - (7) Transmission Case Groove
- A: Position**
B: Position

9Y1210982TRS0071US0

(6) Bevel Pinion Shaft

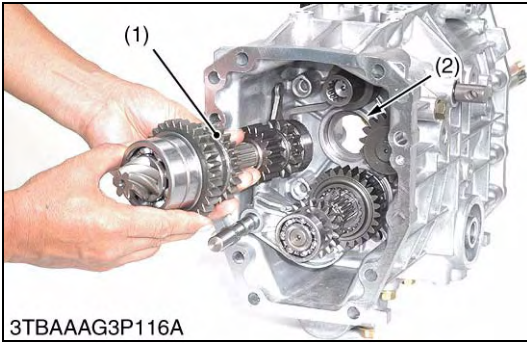

3TBAAAG3P116A

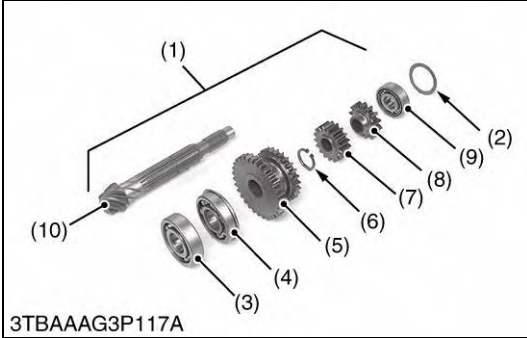

3TBAAAG3P117A

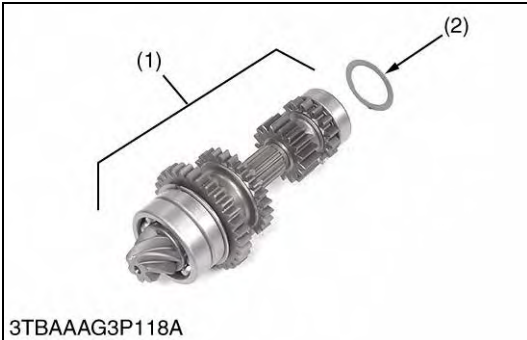

3TBAAAG3P118A

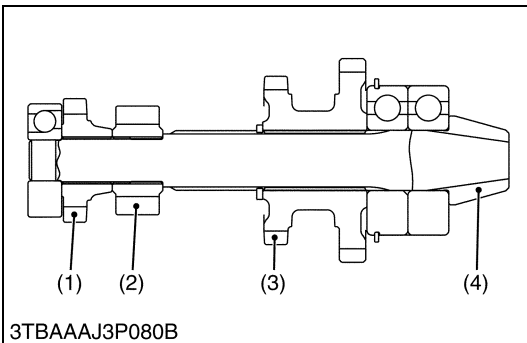

3TBAAAJ3P080B

Bevel Pinion Shaft 1

1. Remove the bevel pinion shaft assembly (1) from the transmission case.
2. Remove the spacer (2).

(When reassembling)

- Install the spacer (2) to the transmission case.
- Install the bevel pinion shaft assembly (1).

- | | |
|---------------------------------|------------------------------|
| (1) Bevel Pinion Shaft Assembly | (6) Cir-clip |
| (2) Spacer | (7) Gear |
| (3) Ball Bearing | (8) Gear |
| (4) Ball Bearing | (9) Ball Bearing |
| (5) Gear | (10) Bevel Pinion Shaft (6T) |

9Y1210982TRS0072US0

Bevel Pinion Shaft 2

Gear teeth number are changed by the tractor models.

(When reassembling)

- Check the gear teeth number and assemble the bevel pinion shaft assembly.

Item	Number of gear teeth	Model
(1)	13	B2050, B2350, B2650
	14	B3150
(2)	12	Manual Transmission
	18	HST
(3)	25-31	Manual Transmission
	24-29	HST

- | | |
|--------------|---------------------------|
| (1) 4WD Gear | (3) Gear |
| (2) Gear | (4) 6T Bevel Pinion Shaft |

9Y1210982TRS0073US0

(7) Range Gear Shaft

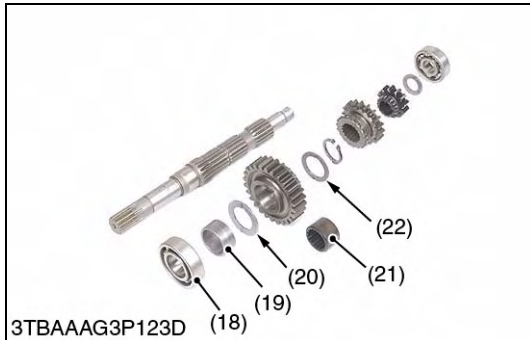
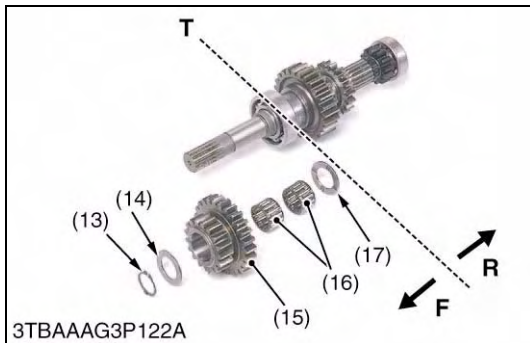
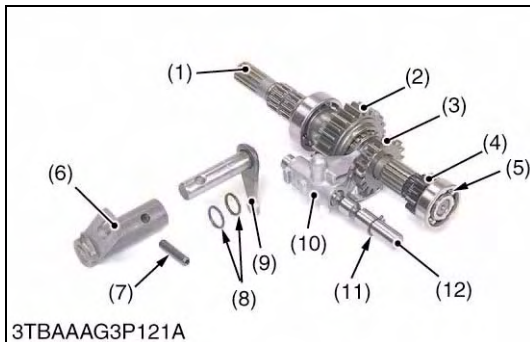
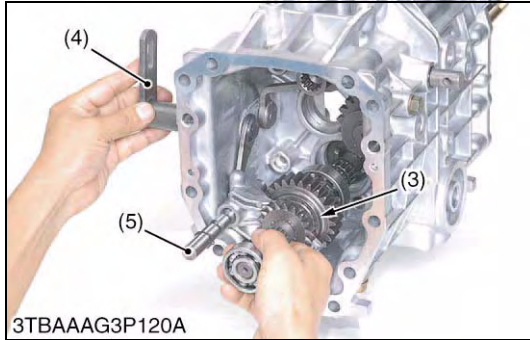
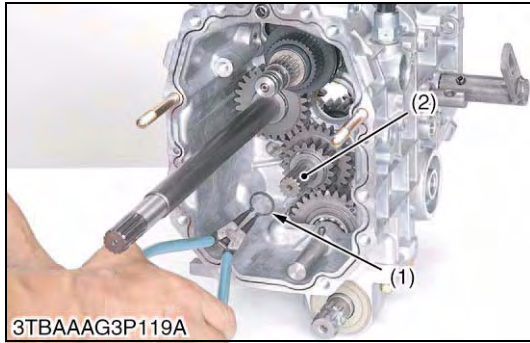

Range Gear Shaft Assembly

1. Remove the cir-clip (1) from the range gear shaft (2).
2. Remove the spring pin from the shift arm lever (4).
3. Remove the range gear shaft assy.(3) and the fork rod (5) from the transmission case.

- (1) Cir-clip
- (2) Range Gear Shaft
- (3) Range Gear Shaft Assembly
- (4) Shift Arm Lever
- (5) Fork Rod

9Y1210982TRS0074US0

Range Gear Shaft and Gears

1. Remove the ball bearing (5) from the rang gear shaft (1).
2. Remove the gear (4), the gear(3) and the gear (2).

(When reassembling)

- Install the range shift arm (9) to the range shift fork (10) securely.
- Install the O-rings (8) to the range shift arm (9).

Item	Number of gear teeth	Model
(1)	31	Manual Transmission
	36	HST
(2)	18	Manual Transmission
	19	HST
(3)	12	Manual Transmission
	14	HST

- (1) Range Gear Shaft
- (2) Gear
- (3) Gear
- (4) Gear
- (5) Ball Bearing
- (6) Shift Arm Lever
- (7) Spring Pin
- (8) O-ring
- (9) Range Shift Arm
- (10) Range Shift Fork
- (11) Cir-clip
- (12) Fork Rod
- (13) Cir-clip
- (14) Collar
- (15) Gear (17-26T)
- (16) Needle Bearing
- (17) Collar
- (18) Ball Bearing
- (19) Collar
- (20) Collar
- (21) Inner Ring
- (22) Collar

T: Transmission Case

F: Front Side

R: Rear Side

9Y1210982TRS0075US0

(8) Front Wheel Drive Shaft

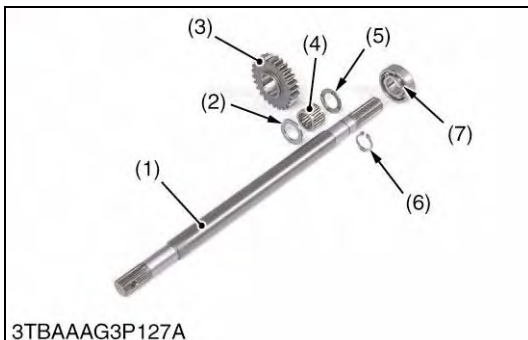
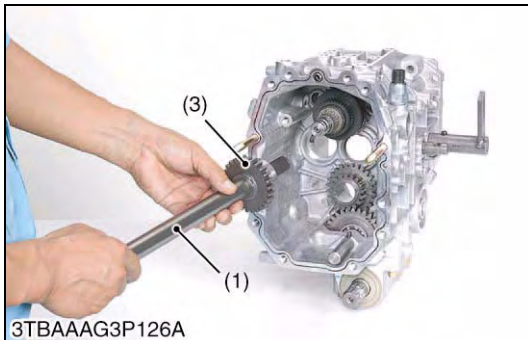
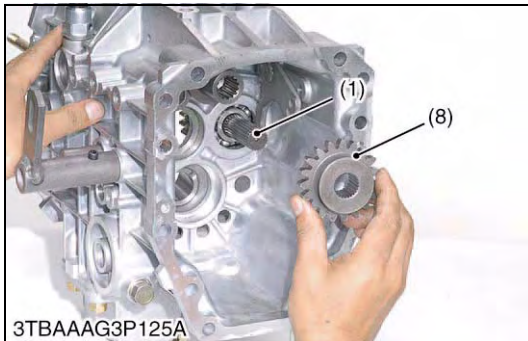
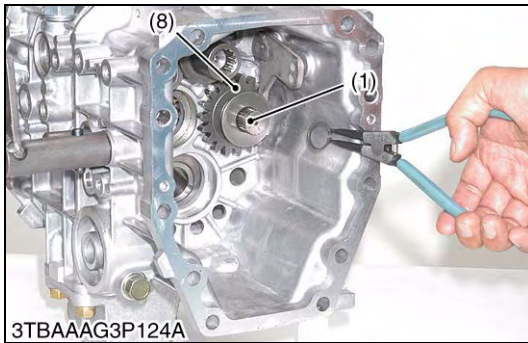

4WD Shaft

1. Remove the cir-clip from the 4WD shaft (1).
2. Remove the 4WD gear (8) from the 4WD shaft (1).
3. Remove the 4WD shaft (1) with the 25T gear (3).
4. Remove the 25T gear (3) and the ball bearing (7).

- | | |
|--------------------|--------------------------|
| (1) 4WD Shaft | (6) Cir-clip |
| (2) Collar | (7) Ball Bearing |
| (3) 25T Gear | (8) 4WD Gear |
| (4) Needle Bearing | B2050, B2350, B2650: 20T |
| (5) Collar | B3150: 19T |

9Y1210982TRS0076US0

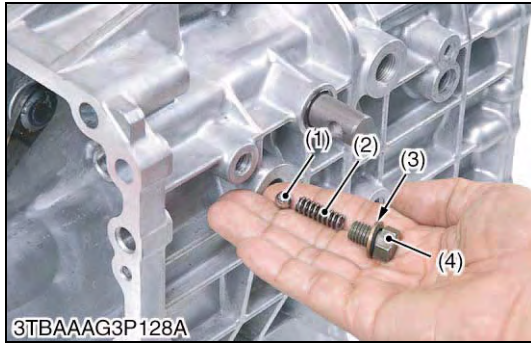

4WD Shaft Arm

1. Remove the bolt (4) and the washer with rubber (3).

(When reassembling)

- Install the 4WD gear (5) to the 4WD shaft.
- Install the 4WD shaft arm (6) to the 4WD gear (5).
- Install the O-rings to the 4WD shaft arm (6).

- | | |
|------------------------|-------------------|
| (1) Ball | (5) 4WD Gear |
| (2) Spring | (6) 4WD Shaft Arm |
| (3) Washer with Rubber | (7) O-ring |
| (4) Bolt | |

9Y1210982TRS0077US0

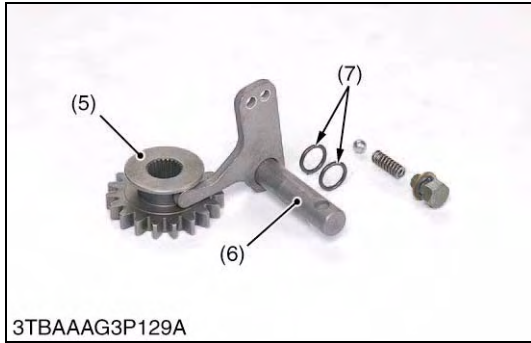

(9) Independent PTO Clutch Shifter

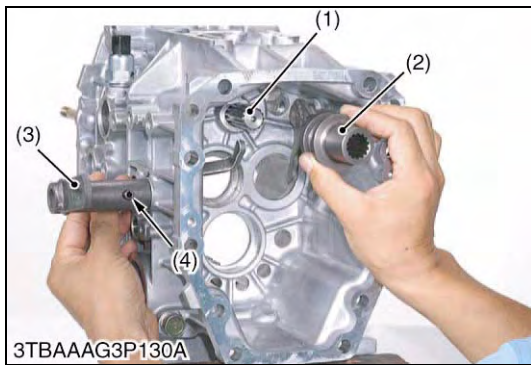

Rear PTO Shifter and Rear PTO Arm

1. Remove the rear PTO shifter (2) from the PTO clutch shaft (1).
2. Remove the spring pin (4) from the rear PTO arm (9).
3. Remove the PTO clutch shaft (1) and the PTO shifter as an assembly.

(When reassembling)

- Install the rear PTO arm (9) to the transmission case.
- After installing the PTO shifter (8) to the PTO clutch shaft (1), install the rear PTO arm (9) to the rear PTO shifter (2).
- Install the O-rings (7) to the rear PTO arm (9).
- Install the PTO lever (3) to the rear PTO arm (9).
- Install the spring pin (4) to the rear PTO arm (9).

- | | |
|----------------------|------------------|
| (1) PTO Clutch Shaft | (6) O-ring |
| (2) Rear PTO Shifter | (7) O-ring |
| (3) PTO Lever | (8) PTO Shifter |
| (4) Spring Pin | (9) Rear PTO Arm |
| (5) PTO Shift Arm | |

9Y1210982TRS0078US0

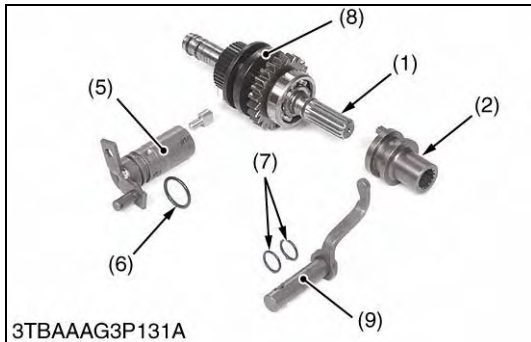

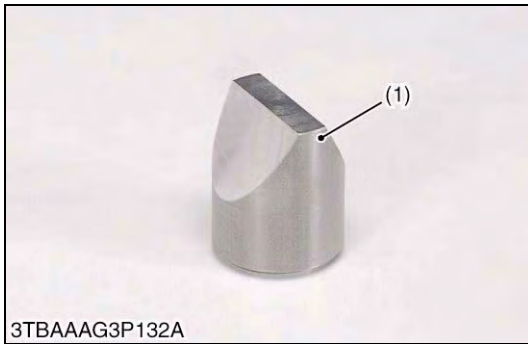

Installing PTO Shifter

1. Install the spring (3) and the ball (2) to the transmission.
2. Push the ball (2) by finger from the inside of the transmission case.
3. Push the PTO shift arm ball guide (1) into the transmission case as shown in the picture.
4. Push the PTO shift arm ball guide (1) with the PTO shift arm (4).
5. Install the PTO cotter (5) to the PTO shift arm (4).
6. Align the PTO cotter to the groove of the PTO shifter (6).

- | | |
|------------------------------|-------------------|
| (1) PTO Shift Arm Ball Guide | (4) PTO Shift Arm |
| (2) Ball | (5) PTO Cotter |
| (3) Spring | (6) PTO Shifter |

9Y1210982TRS0079US0

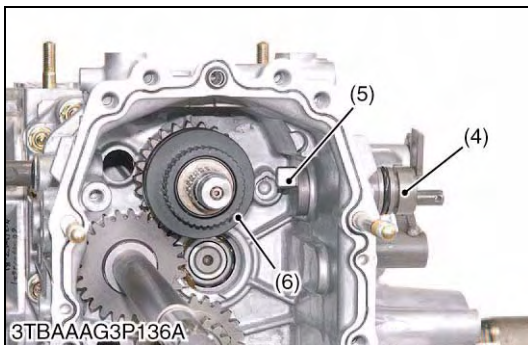
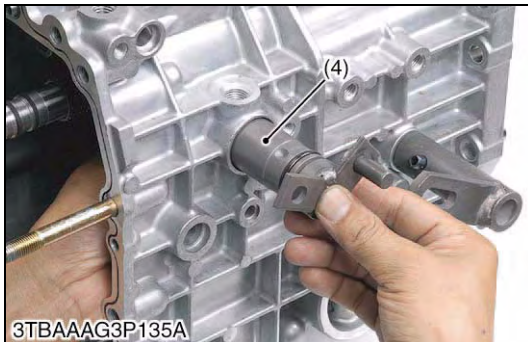
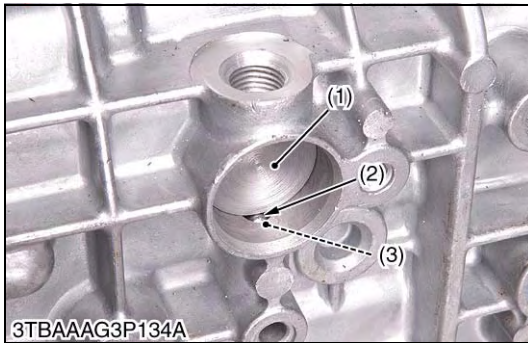
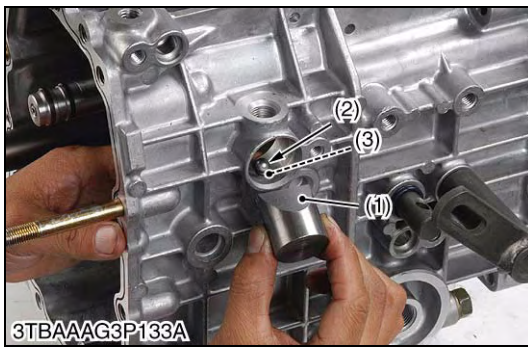

(10) Independent PTO Clutch

PTO Clutch Case

1. Remove the external cir-clip (11) from the spline boss (12).
2. Remove the internal cir-clip (13) from the PTO clutch case (2).
3. Remove the clutch disks (9) and the clutch plates (10) from the PTO clutch case (2).
4. Remove the ball bearing (1) from the PTO clutch case (2) with a puller.

■ **NOTE**

- **When removing the cir-clip, use an adequate size snap ring pliers.**

- | | |
|----------------------|------------------------|
| (1) Ball Bearing | (8) 26T Mid PTO Gear |
| (2) PTO Clutch Case | (9) Clutch Disk |
| (3) Brake Plate 4 | (10) Clutch Plate |
| (4) Brake Plate 2 | (11) External Cir-clip |
| (5) PTO Clutch Shaft | (12) Spline Boss |
| (6) Thrust Bearing | (13) Internal Cir-clip |
| (7) PTO Shifter | |

9Y1210982TRS0080US0

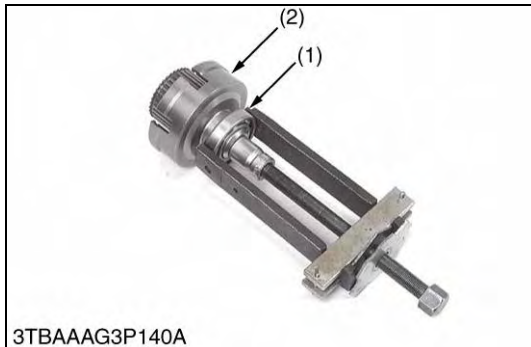
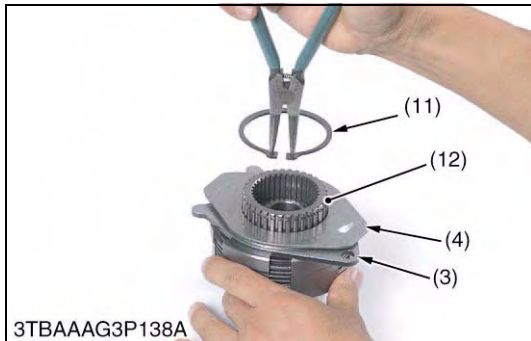
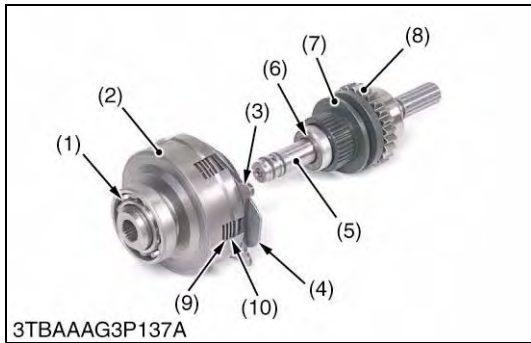

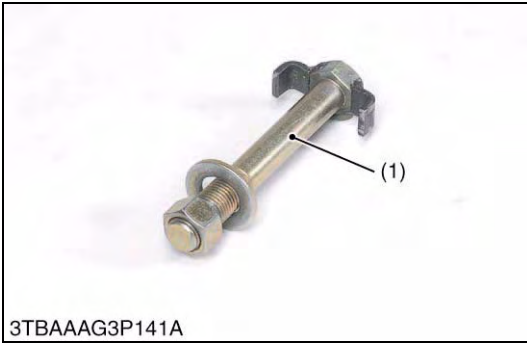

PTO Clutch Spring

1. Set the PTO clutch spring compressor (1) to the PTO clutch case (2).
2. Tighten the nut and remove the external cir-clip (3).
3. Remove the spring collar (4) and the PTO clutch spring (5).

- | | |
|----------------------------------|-----------------------|
| (1) PTO Clutch Spring Compressor | (4) Spring Collar |
| (2) PTO Clutch Case | (5) PTO Clutch Spring |
| (3) External Cir-clip | |

9Y1210982TRS0081US0

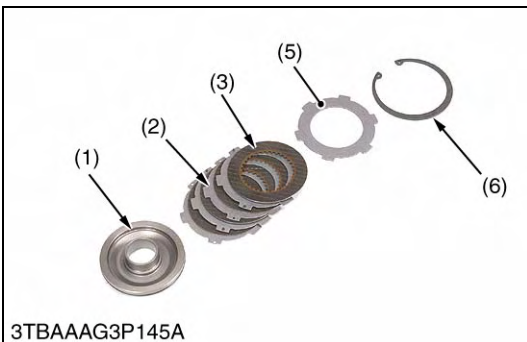
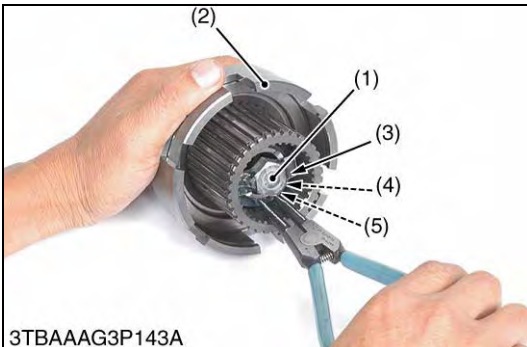
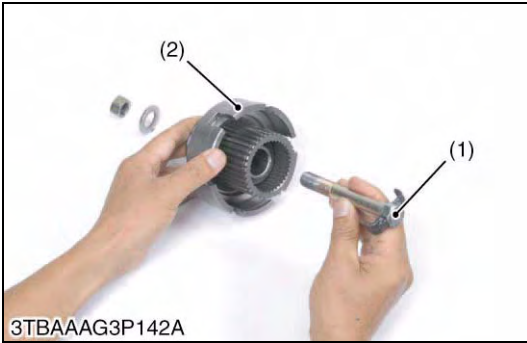

PTO Clutch Disks and Brake

1. After removing the inner cir-clip (7) from the PTO clutch case (11), remove the pressure plate (6).
2. Remove the clutch disks (4) and clutch plates (3).
3. Remove the external cir-clip (17) from the spline boss (5).
4. Remove the brake plate (16), the brake disks (15) and the brake plate (14).
5. After removing the external cir-clip (9), remove the spring collar (8) and the spring (19).

(When reassembling)

- Install the parts to the original positions.

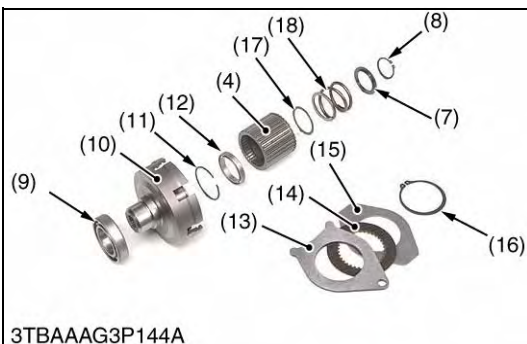

- | | |
|-----------------------|------------------------|
| (1) Clutch Piston | (11) PTO Clutch Case |
| (2) O-ring | (12) Cir-clip |
| (3) Clutch Plate | (13) Ball Bearing |
| (4) Clutch Disk | (14) Brake Plate |
| (5) Spline Boss | (15) PTO Brake Disk |
| (6) Pressure Plate | (16) Brake Plate |
| (7) Internal Cir-clip | (17) External Cir-clip |
| (8) Spring Collar | (18) Bearing Collar |
| (9) External Cir-clip | (19) Spring |
| (10) Ball Bearing | |

9Y1210982TRS0082US0

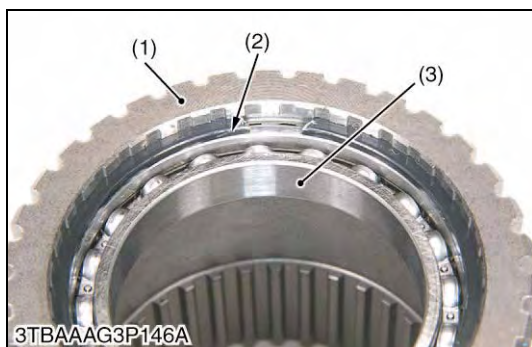

Spline Boss Cir-clip

1. Push the cir-clip with a small screw driver through the small hole of the spline boss (1).
2. Lift the cir-clip (2) with a screw driver not to damage it.

(When reassembling)

- Install the cir-clip (2) holding it by hands.

(1) Spline Boss

(3) Ball Bearing

(2) Cir-clip

9Y1210982TRS0083US0



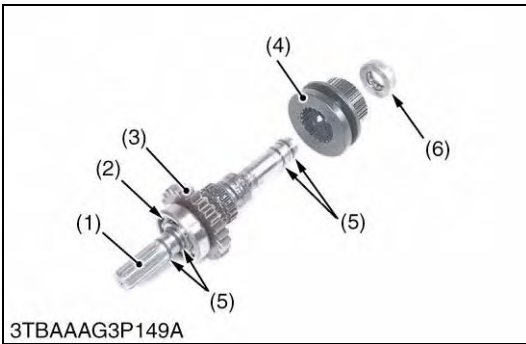

PTO Shaft

1. Remove the thrust bearing (6) and the PTO shifter (4) not to damage the seal rings (5) located at the PTO shaft front side.
2. Remove the seal rings (5) located at the PTO shaft rear side.
3. Remove the ball bearing (2) with a puller.

(When reassembling)

- Check all seal rings (5).
- If the seal ring (5) is damaged, replace it.
- Check the direction of the thrust bearing (6) and install the thrust bearing (6) as shown in the picture.



- | | |
|----------------------|--------------------|
| (1) PTO Clutch Shaft | (5) Seal Ring |
| (2) Ball Bearing | (6) Thrust Bearing |
| (3) 26T Mid-gear | (7) Needle Bearing |
| (4) PTO Shifter | (8) Collar |

9Y1210982TRS0084US0

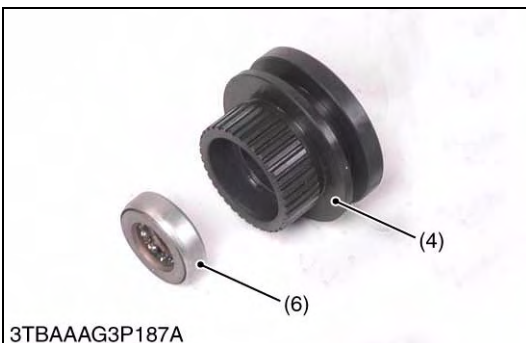
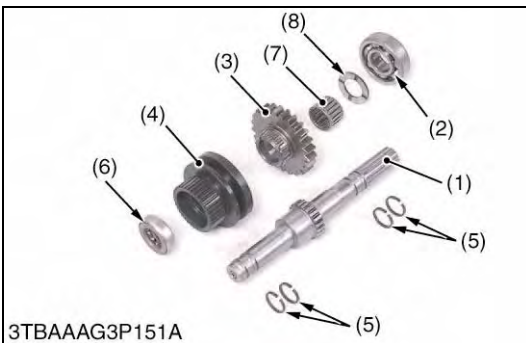

(11) Mid-PTO Section

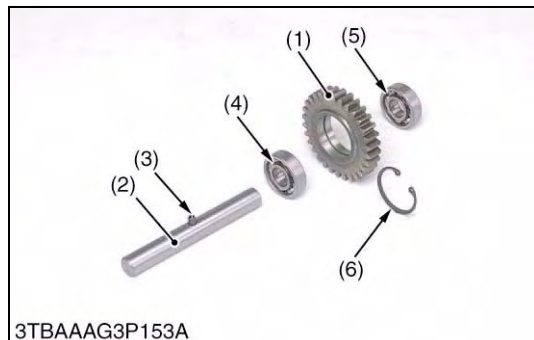
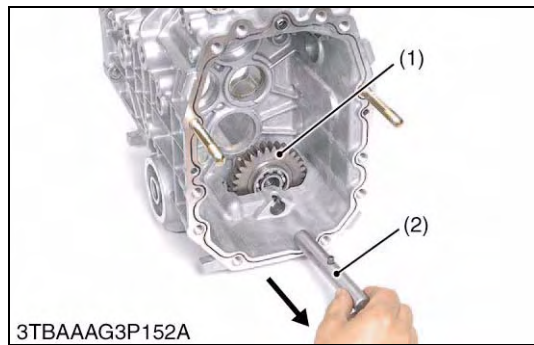

Mid-gear and Idle Shaft (Mid-PTO Model)

1. Remove the idle shaft (2) from the transmission case using a screw driver.
2. Remove the mid-gear (1) from the transmission case.
3. Remove the ball bearings (4), (5) and the internal cir-clip (6) from the mid-gear (1).

(When reassembling)

- Install the internal cir-clip (6) to the inner groove of the mid-gear (1) securely.

- (1) 30T Mid-gear
 (2) Idle Shaft
 (3) Spring Pin

- (4) Ball Bearing
 (5) Ball Bearing
 (6) Internal Cir-clip

9Y1210982TRS0085US0

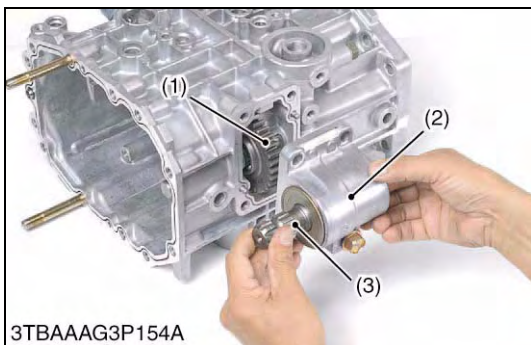

3TBAAAG3P154A

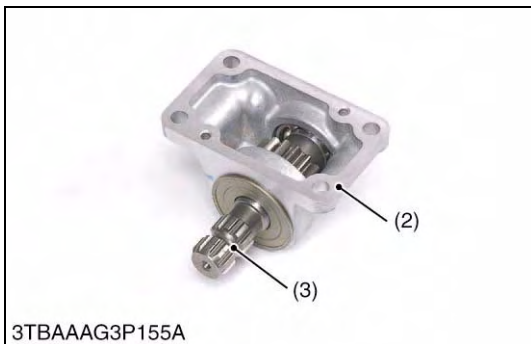

3TBAAAG3P155A

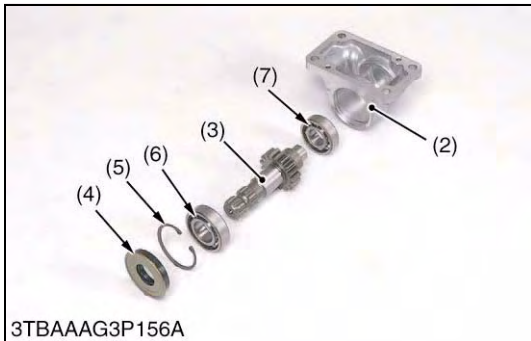

3TBAAAG3P156A

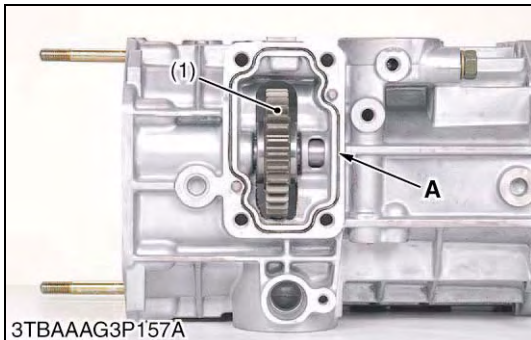

3TBAAAG3P157A

Mid-PTO Case and Mid-gear Shaft (Mid-PTO Model)

1. Remove the mid-PTO case mounting bolts.
2. Remove the mid-PTO case from the transmission case.
3. Remove the mid-PTO oil seal (4) from the mid-PTO case (2) using a screw driver not to damage it.
4. Remove the internal cir-clip (5).
5. Remove the mid-gear shaft (3) with the ball bearings (6), (7).
6. Remove the bearing (6), (7) from the mid-gear shaft (3).

(When reassembling)

- If the mid-PTO oil seal (4) is damaged, worn or scratched, replace it.
- Apply grease to the lip and the outer of the mid-PTO oil seal (4).
- Apply liquid gasket (Three Bond 1206D or equivalent) to the joint surface A of the transmission case and the mid-PTO case (2).

- | | |
|--------------------------|-------------------------|
| (1) 30T Mid-gear | (6) Ball Bearing |
| (2) Mid-PTO Case | (7) Ball Bearing |
| (3) Mid-gear Shaft (17T) | |
| (4) Mid-PTO Oil Seal | A: Joint Surface |
| (5) Internal Cir-clip | |

9Y1210982TRS0086US0

(12) Differential Gear Section

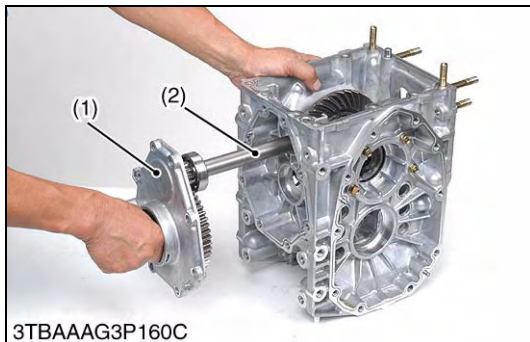
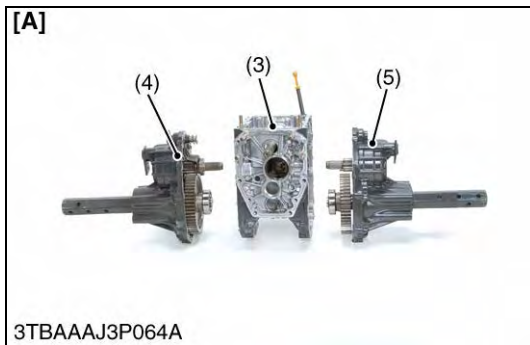
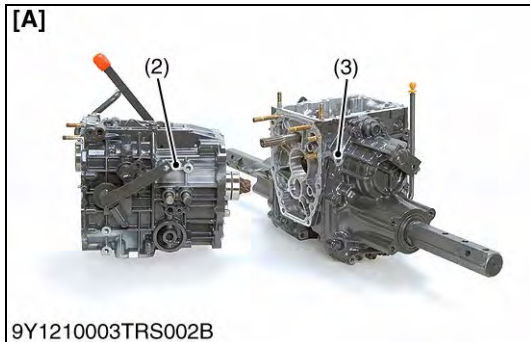
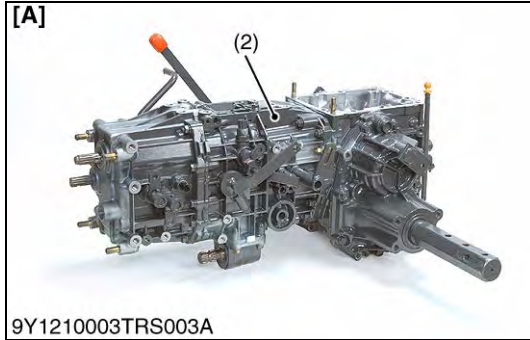
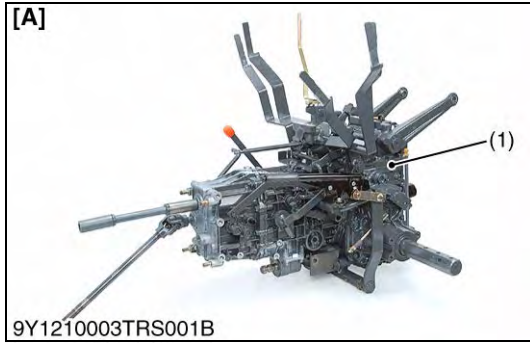

Separating Hydraulic Cylinder, Transmission Case and Rear Axles

1. Remove the hydraulic cylinder as an assembly.
2. Separate the transmission case.
3. Separate the rear axles.

(When reassembling)

Tightening torque	Hydraulic cylinder mounting bolt (M10)	39.3 to 44.1 N·m 4.0 to 4.5 kgf·m 28.9 to 32.5 lbf·ft
	Transmission case mounting bolt and nut (M10)	39.3 to 44.1 N·m 4.0 to 4.5 kgf·m 29.0 to 32.5 lbf·ft
	Rear axle case mounting bolt (M10)	39.3 to 44.1 N·m 4.0 to 4.5 kgf·m 29.0 to 32.5 lbf·ft

- (1) Hydraulic Cylinder Assembly
- (2) Transmission Case
- (3) Differential Case
- (4) Rear Axle Case, R.H.
- (5) Rear Axle Case, L.H.

[A] Manual Transmission Model

9Y1210982TRS0087US0

Rear-PTO Case and Rear PTO Shaft

1. Remove the rear PTO cover mounting bolts and the rear PTO cover (1).

(When reassembling)

- Apply liquid gasket (Three Bond 1206D or equivalent) to the joint surface of the rear axles cases and the rear PTO cover.

Tightening torque	Rear PTO cover mounting bolt for aluminum (M10)	39.3 to 44.1 N·m 4.0 to 4.5 kgf·m 29.0 to 32.5 lbf·ft
-------------------	---	---

- (1) Rear PTO Cover

- (2) PTO Drive Shaft

9Y1210982TRS0088US0

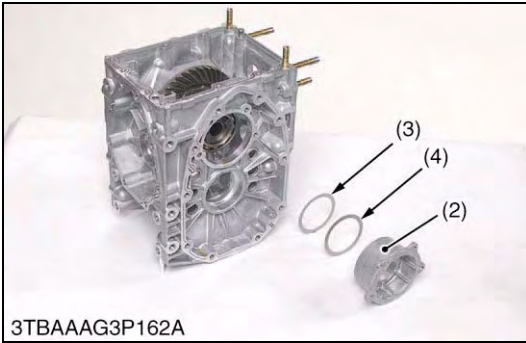
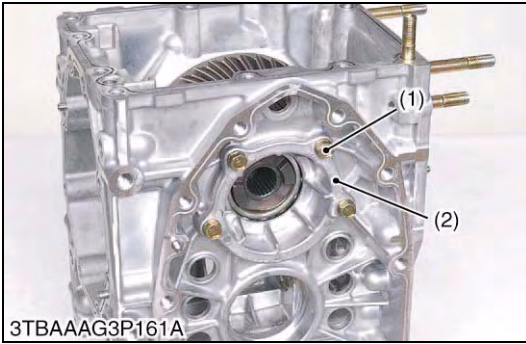

Differential Bearing Holder (R.H.)

1. Remove the differential holder mounting bolts (1).
2. Remove the differential holder (2) and shims (3), (4).

(When reassembling)

- 0.5 mm (0.020 in.) shim Parts No. 66611-1514-0
- 0.2 mm (0.008 in.) shim Parts No. 66611-1515-0

Tightening torque	Differential bearing holder mounting bolt for aluminum (M8)	17.7 to 20.5 N·m 1.8 to 2.1 kgf·m 13.1 to 15.1 lbf·ft
-------------------	---	---

- (1) Differential Bearing Holder Mounting Bolt
 (2) Differential Bearing Holder
 (3) Shim
 (4) Shim

9Y1210982TRS0089US0

[4] SERVICING

(1) Bi-Speed Turn Clutch

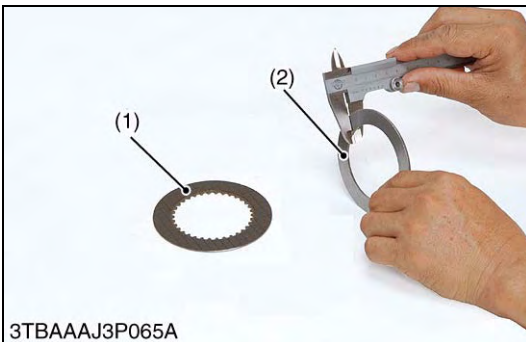

Clutch Disk and Clutch Plate

1. Measure the clutch disk thickness with a vernier calipers.
2. Measure the clutch plate thickness with a vernier calipers.
3. If the thickness is less than the allowable limit, replace it.
4. If the bearing is worn, replace it.

Bi-Speed Turn clutch disk thickness	Factory specification	1.70 to 1.90 mm 0.067 to 0.075 in.
	Allowable limit	1.55 mm 0.061 in.

Bi-Speed Turn clutch disk plate thickness	Factory specification	1.95 to 2.05 mm 0.0768 to 0.0807 in.
	Allowable limit	1.8 mm 0.071 in.

- (1) Clutch Disk
 (2) Clutch Disk Plate

9Y1210982TRS0090US0

(2) Mechanical PTO Clutch

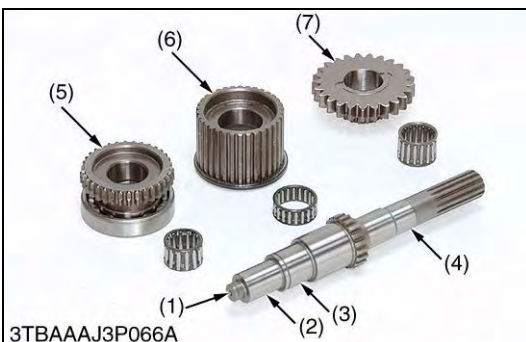

PTO Clutch Shaft

1. Check the needle bearings.
2. Check the needle bearing surfaces (2), (3), (4) of the PTO clutch shaft (1).
3. Check the needle bearing surfaces of the one-way clutch spline boss (5), the PTO brake spline boss (6) and the 26T mid-PTO gear (7).
4. If the PTO clutch shaft is rough or grooved, replace it.
5. If the needle bearing is wore, replace it.
6. The one-way clutch spline boss (5), the PTO brake spline boss (6) or the 26T mid-PTO gear (7) is worn, replace it.

- (1) PTO Clutch Shaft
 (2) Needle Bearing Surface
 (3) Needle Bearing Surface
 (4) Needle Bearing Surface
 (5) One-way Clutch Spline Boss
 (6) PTO Brake Spline Boss
 (7) 26T Mid-PTO Gear

9Y1210982TRS0091US0

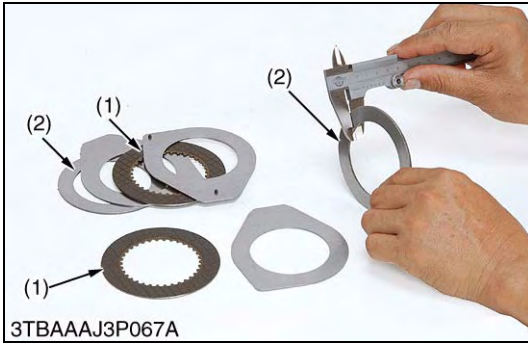

PTO Brake Disk and Brake Plate 1

1. Measure the PTO brake disk thickness with a vernier calipers.
2. Measure the brake plate thickness with a vernier calipers.
3. If the thickness is less than the allowable limit, replace it.

PTO brake disk thickness	Factory specification	1.70 to 1.90 mm 0.067 to 0.075 in.
	Allowable limit	1.55 mm 0.061 in.
Mechanical PTO brake plate 1 thickness	Factory specification	1.95 to 2.05 mm 0.0768 to 0.0807 in.
	Allowable limit	1.8 mm 0.071 in.

(1) PTO Brake Disk

(2) Brake Plate 1

9Y1210982TRS0092US0

(3) HST

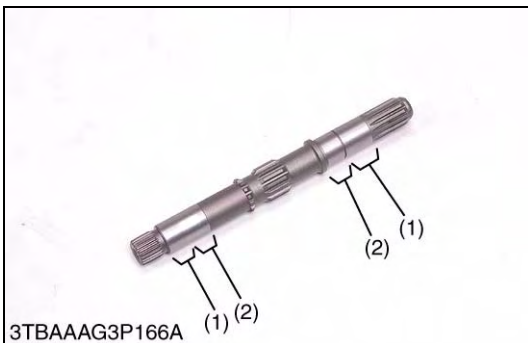

Pump Shaft

1. Pull out the pump shaft from the HST housing case.
2. Check the oil seal surface (1) the bearing surface (2) and the bearing.
3. If the shaft is rough or grooved, replace it.
4. If the bearing is worn, replace it.

(1) Oil Seal Surface

(2) Bearing Surface

9Y1210982TRS0093US0

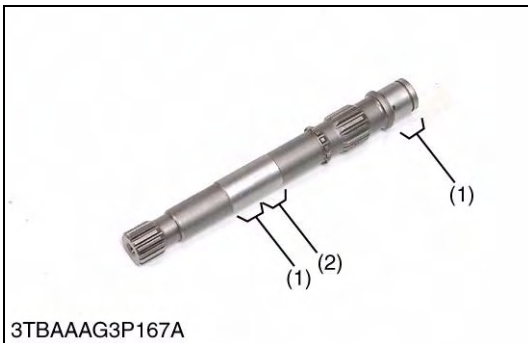

Motor Shaft

1. Pull out the motor shaft from the HST housing case.
2. Check the oil seal surface (1) the bearing surface (2) and the bearing.
3. If the shaft is rough or grooved, replace it.
4. If the bearing is worn, replace it.

(1) Oil Seal Surface

(2) Bearing Surface

9Y1210982TRS0094US0



Cylinder Block Bore and Pistons

1. Lift all the pistons gently with the retainer plate (1).
2. Check the pistons for their free movement in the cylinder block bores.
3. If the piston or the cylinder block bore is scored, replace cylinder block assembly.

IMPORTANT

- Do not interchange pistons between pump and motor cylinder block. Pistons and cylinder blocks are matched.

(1) Retainer Plate

(2) Piston Slipper

9Y1210982TRS0095US0

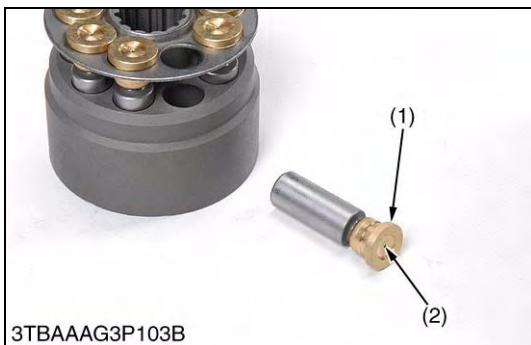

Piston Slipper and Retainer Plate

1. Check the slipper (1) for flatness.
2. If rounded, replace piston.
3. Measure the thickness of piston slipper.
4. If the measurement is less than the allowable limit, replace the piston.
5. Check the lubricant hole (2) for clogging.

IMPORTANT

- **Do not interchange pistons between pump and motor cylinder block. Pistons and cylinder blocks are matched.**

Thickness of slipper	Factory specification	3.00 mm 0.118 in.
	Allowable limit	2.90 mm 0.114 in.

- (1) Piston Slipper (2) Lubricant Hole

9Y1210982TRS0096US0

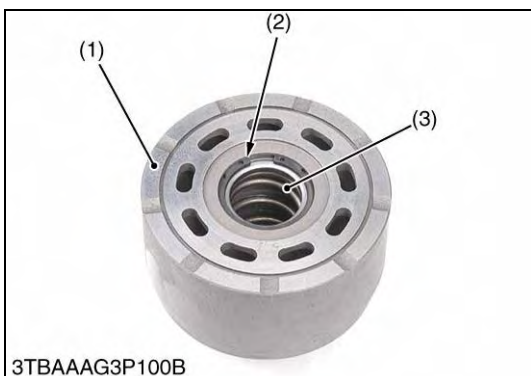

Cylinder Block Face

1. Check the polished face (1) of cylinder block for scoring.
2. If scored, replace cylinder block assembly.
3. Check the spring (3) for breakage.
4. If broken, replace cylinder block assembly.

- (1) Polished Face (2) Cir-clip (3) Spring

9Y1210982TRS0097US0

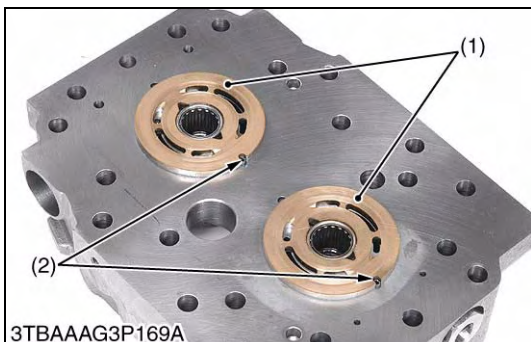

Valve Plate and Center Section Face

1. Check the engagement of the valve plate (1) and the anchor pin (2).
2. Pushing the valve plate (1) against the anchor pin (2), lift it to remove.
3. Check the valve plate (1) for foreign particles.
4. Clean the valve plate (1) and dry with compressed air.
5. Check the valve plate (1) for scratches, wear and erosion. (Run a finger nail across the valve plate surface. If worn, it will be felt.)
6. If worn or scored, replace it.

NOTE

- **After checking, coat them with hydrostatic transmission oil.**

- (1) Valve Plates (2) Anchor Pin (3) Center Section Face

9Y1210982TRS0098US0

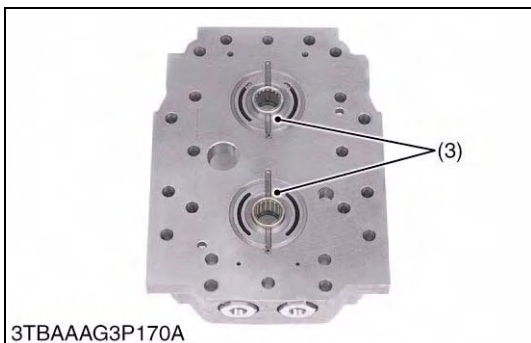

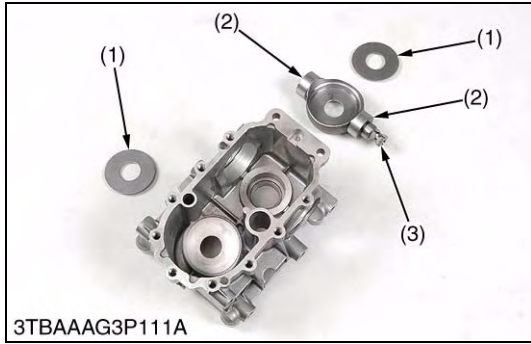

Thrust Collars and Bearing Surface

1. Check the thrust collars (1) for scratches and excessive wear.
2. If worn or scored, replace it.
3. Check the bearing surface (2) of trunnion shaft (swashplate)(3) for scratches and excessive wear.
4. If worn or scored, replace it.

- (1) Thrust Collars
- (2) Bearing Surface
- (3) Trunnion Shaft

9Y1210982TRS0099US0

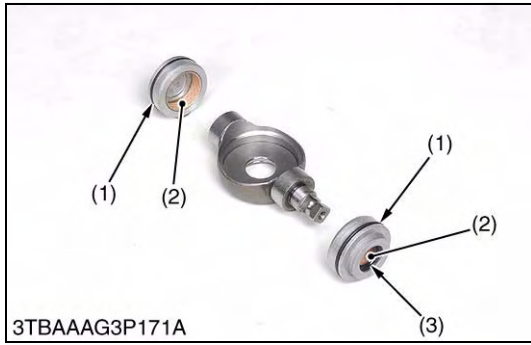

Trunnion Shaft Cover

1. Check the bearing (2) for scratches and excessive wear.
2. If worn or scored, replace it.
3. Check the oil seal (3) and the O-rings (1) for damage.

NOTE

- After checking, coat the bearings with hydrostatic transmission oil, and the oil seal lip and the O-rings (1) with grease.

- (1) O-ring
- (2) Bearing
- (3) Oil Seal

9Y1210982TRS0100US0

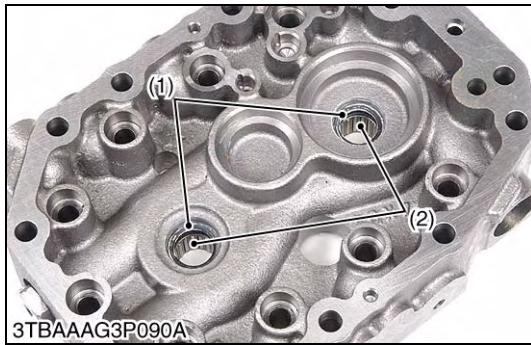

Center Section Oil Seals and Bearings

1. Check the oil seals (1) for damage.
2. Check the needle bearings (2) for wear.
3. If the needle bearings (2) and oil seals (1) are worn, replace all seals and needle bearings.

NOTE

- After checking, coat the bearing with hydrostatic transmission oil and the oil seal lip with grease.

- (1) Oil Seal
- (2) Needle Bearing

9Y1210982TRS0101US0

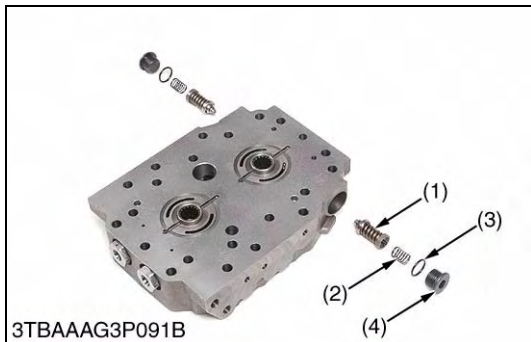

Check and High Pressure Relief Valve

1. Check the valve plug (4) and valve (1) for scratches and damage.
2. Check the valve seat in the port block for damage.
3. Check the spring (2) for breakage and wear.
4. If anything unusual, replace the check and high pressure relief valve assembly.

Tightening torque	Valve plug	118 to 147 N·m 12.0 to 15.0 kgf·m 86.8 to 108.5 lbf·ft
-------------------	------------	--

- (1) Valve
- (2) Spring
- (3) O-ring
- (4) Valve Plug

9Y1210982TRS0102US0

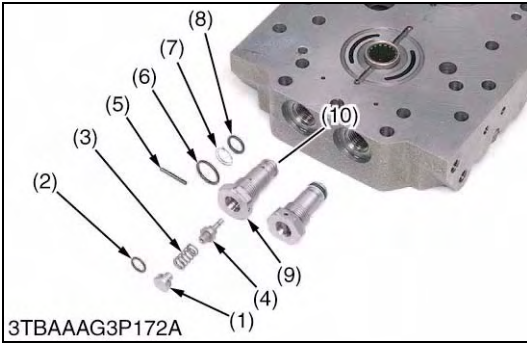

Neutral Valve

1. Check the holes of the valve body (9) and the neutral valve (4) for clogging.
2. If clogged, open hole with compressed air.
3. Replace the O-rings (2), (6), (8) and the backup ring (7) for scratches and damage.
4. Check the springs for breakage and wear.
5. If the valve surface is scored, replace it.
6. If anything is unusual, replace it.

Tightening torque	Neutral valve plug	58.5 to 68.6 N·m 6.0 to 7.0 kgf·m 43.4 to 50.6 lbf·ft
-------------------	--------------------	---

- | | |
|-------------------|-----------------|
| (1) Plug | (6) O-ring |
| (2) O-ring | (7) Backup Ring |
| (3) Spring | (8) O-ring |
| (4) Neutral Valve | (9) Valve Body |
| (5) Pin | (10) Plug |

9Y1210982TRS0103US0

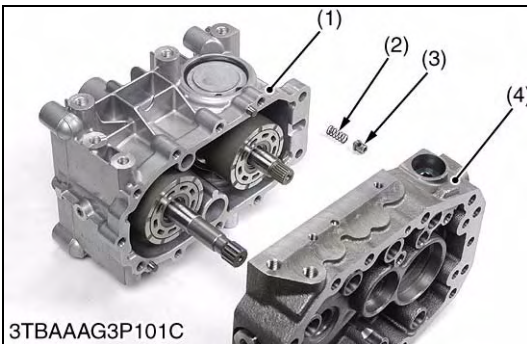

Charge Relief Valve

1. Check the spring (2) for breakage and wear.
2. If it is unusual, replace it.

- | | |
|-----------------|--------------------|
| (1) HST Housing | (3) Poppet |
| (2) Spring | (4) Center Section |

9Y1210982TRS0104US0

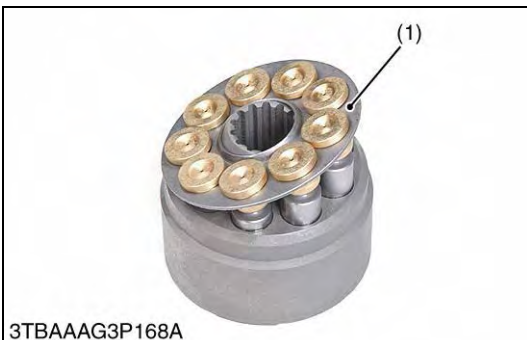

Cylinder Block Bore and Pistons

1. Lift all the pistons gently with the retainer plate (1).
2. Check the pistons for their free movement in the cylinder block bores.
3. If the piston or the cylinder block bore is scored, replace cylinder block assembly.

IMPORTANT

- Do not interchange pistons between pump and motor cylinder block. Pistons and cylinder blocks are matched.

Clearance between piston and bore	Factory specification	0.02 mm 0.0008 in.
	Allowable limit	0.04 mm 0.0016 in.

- (1) Retainer Plate

9Y1210982TRS0105US0

(4) Independent PTO Clutch



Checking Bearing

1. Hold the inner race, and push and pull the outer race in all directions to check for wear and roughness.
2. Apply transmission fluid to the bearing, and hold the inner race. Then, turn the outer race to check rotation.
3. If there is any problem, replace it.

9Y1210982TRS0106US0

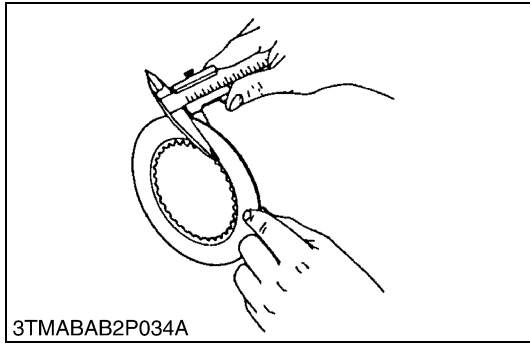

3TMABAB2P034A

Clutch Disc Wear

1. Measure the clutch disc thickness with vernier calipers.
2. If the thickness is less than the allowable limit, replace it.

Clutch disc wear	Factory specification	1.70 to 1.90 mm 0.067 to 0.075 in.
	Allowable limit	1.55 mm 0.061 in.

9Y1210982TRS0107US0

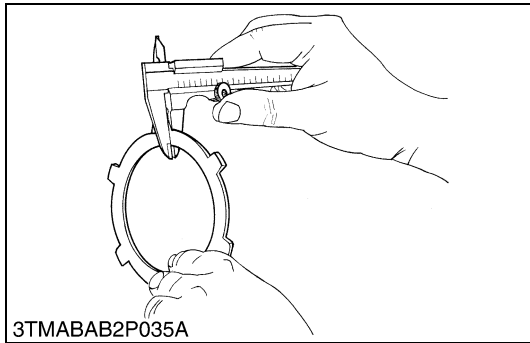

3TMABAB2P035A

Steel Plate and Pressure Plate Wear

1. Measure the steel plate thickness with vernier calipers.
2. Measure the pressure plate thickness with vernier calipers.
3. If the thickness is less than the allowable limit, replace.

Steel plate wear (without hole)	Factory specification	0.95 to 1.05 mm 0.0374 to 0.0413 in.
	Allowable limit	0.8 mm 0.031 in.
Steel plate wear (with holes, with holes and rubber plugs)	Factory specification	1.15 to 1.25 mm 0.045 to 0.049 in.
	Allowable limit	1.10 mm 0.043 in.

Pressure plate wear	Factory specification	1.95 to 2.05 mm 0.0768 to 0.0807 in.
	Allowable limit	1.8 mm 0.071 in.

9Y1210982TRS0108US0

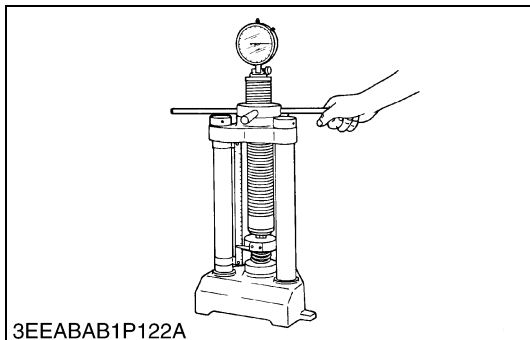

3EEABAB1P122A

Piston Return Spring Free Length and Tension

1. Measure the free length of the piston return spring with vernier calipers.
2. Place the piston return spring on a spring compression tester and compress to the specified length, and read the gauge.
3. If the measurement is less than the allowable limit, replace.

Piston / return spring free length	Factory specification	34.5 mm 1.36 in.
------------------------------------	-----------------------	---------------------

Piston return spring tension	Factory specification	614.2 N / 17.8 mm 62.7 kgf / 17.8 mm 138.1 lbf / 0.70 in.
	Allowable limit	518.7 N / 17.8 mm 53.0 kgf / 17.8 mm 116.6 lbf / 0.70 in.

9Y1210982TRS0109US0

(5) Transmission Case



3TBAAAG3P174A

Checking Bearing

1. Hold the inner race, and push and pull the outer race in all directions to check for wear and roughness.
2. Apply transmission fluid to the bearing, and hold the inner race. Then, turn the outer race to check rotation.
3. If there is any problem, replace it.

9Y1210982TRS0110US0

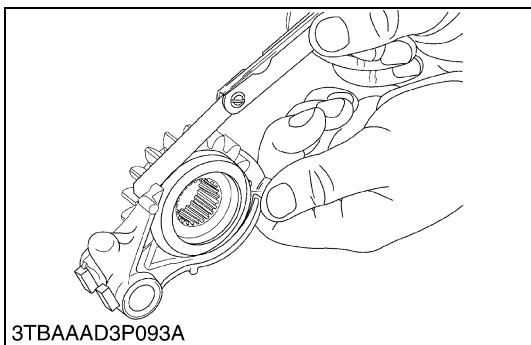

Clearance between Shift Fork and Shift Gear Groove

1. Insert the fork into the shift gear groove and measure the clearance with a feeler gauge.
2. If the clearance exceeds the allowable limit, replace it.

Clearance between shift fork and shift gear groove	Factory specification	0.10 to 0.35 mm 0.004 to 0.014 in.
	Allowable limit	0.5 mm 0.020 in.

9Y1210982TRS0111US0

(6) Differential Gear

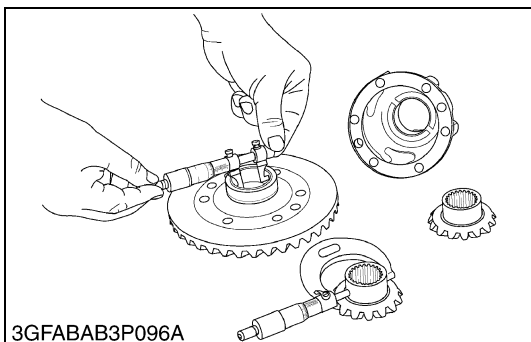

Clearance between Differential Case (Spiral Bevel Gear) and Differential Side Gear

1. Measure the differential side gear boss O.D. with an outside micrometer.
2. Measure the differential case I.D. and the spiral bevel gear I.D. with an inside micrometer, and calculate the clearance.
3. If the clearance exceeds the allowable limit, replace damage parts.

Clearance between differential case (spiral bevel gear) and differential side gear	Factory specification	0.025 to 0.066 mm 0.0010 to 0.0025 in.
	Allowable limit	0.30 mm 0.0118 in.

Differential case I.D.	Factory specification	32.000 to 32.025 mm 1.2599 to 1.2608 in.
Spiral bevel gear I.D.	Factory specification	32.000 to 32.025 mm 1.2599 to 1.2608 in.
Differential side gear O.D.	Factory specification	31.959 to 31.975 mm 1.2582 to 1.2589 in.

9Y1210982TRS0112US0

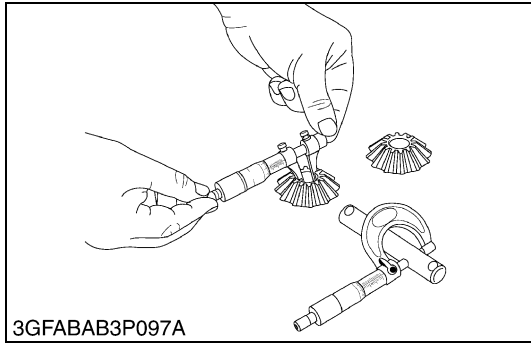

3GFABAB3P097A

Clearance between Differential Pinion Shaft and Differential Pinion

1. Measure the differential pinion shaft O.D. with an outside micrometer.
2. Measure the differential pinion I.D. with an inside micrometer, and calculate the clearance.
3. If the clearance exceeds the allowable limit, replace damage parts.

[B3150]

Clearance between differential pinion shaft and differential pinion	Factory specification	0.048 to 0.084 mm 0.0019 to 0.0033 in.
	Allowable limit	0.30 mm 0.0118 in.

Differential pinion I.D.	Factory specification	16.032 to 16.050 mm 0.63119 to 0.63188 in.
Differential pinion shaft O.D.	Factory specification	15.966 to 15.984 mm 0.62859 to 0.62929 in.

[B2050, B2350, B2650]

Clearance between differential pinion shaft and differential pinion	Factory specification	0.048 to 0.084 mm 0.0019 to 0.0033 in.
	Allowable limit	0.30 mm 0.012 in.

Differential pinion I.D.	Factory specification	14.032 to 14.050 mm 0.55244 to 0.55314 in.
Differential pinion shaft O.D.	Factory specification	13.966 to 13.984 mm 0.54985 to 0.55055 in.

9Y1210982TRS0113US0

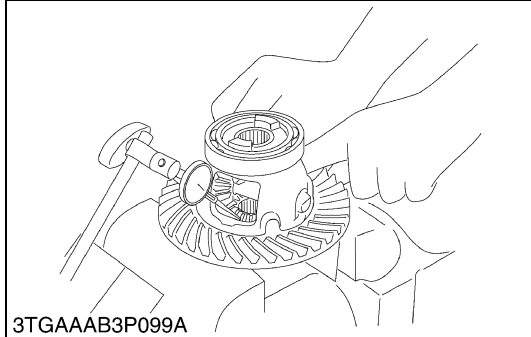

3TGAAAB3P099A

Backlash between Differential Pinion and Differential Side Gear

1. Secure the differential case with a vise.
2. Set the dial indicator (lever type) with its finger on the tooth of the differential side gear.
3. Press differential pinion and side gear against the differential case.
4. Hold the differential pinion and move the differential side gear to measure the backlash.
5. If the backlash exceeds the allowable limit, adjust with differential side gear shims.

Backlash between differential pinion and differential side gear	Factory specification	0.1 to 0.3 mm 0.004 to 0.011 in.
	Allowable limit	0.4 mm 0.016 in.

NOTE

- **Thickness of shims:**
0.80 mm (0.0315 in.) [Parts No. 67211-15170]
1.00 mm (0.0394 in.) [Parts No. 67211-15160]
1.20 mm (0.0472 in.) [Parts No. 67211-15180]

9Y1210982TRS0114US0

Backlash between Spiral Bevel Pinion and Spiral Bevel Gear

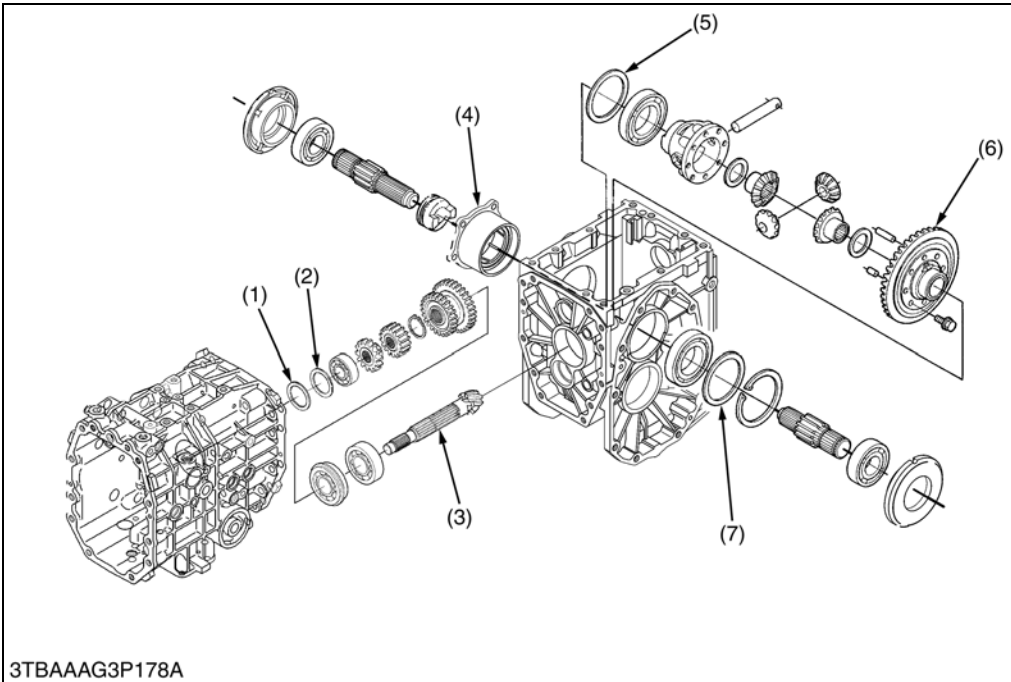

- (1) Shim
- (2) Spacer
- (3) Spiral Bevel Pinion
- (4) Bearing Holder
- (5) Shim
- (6) Spiral Bevel Gear
- (7) Shim

3TBAAAG3P178A

1. Set the dial indicator (lever type) with its finger on the end of spiral bevel pinion (3).
2. Move the spiral bevel pinion back and forth to each end and measure the side clearance.
3. If the side clearance exceeds the factory specifications, adjust with the shims (2) at front end of spiral bevel pinion.
4. Set the dial indicator (lever type) with its finger on the tooth surface of bevel gear.
5. Measure the backlash by fixing the spiral bevel pinion (3) and moving bevel gear (6) by hand.
6. If the backlash exceeds the factory specifications, adjust with the shims (2), (7) at bearing holder (4) and differential case.
7. Adjust the backlash properly by repeating the above procedure.

(When adjusting)

Movement of spiral bevel pinion shaft at shaft directions	Factory specification	Approx. 0 mm 0 in.
Backlash between spiral bevel pinion and spiral bevel gear	Factory specification	0.10 to 0.30 mm 0.0040 to 0.011 in.

(Reference)

- Thickness of shims (1):
0.2 mm (0.008 in.)
1.4 mm (0.056 in.)
1.8 mm (0.070 in.)
- Thickness of shims (5):
0.2 mm (0.008 in.)
0.5 mm (0.01 in.)
- Thickness of shims (7):
0.5 mm (0.01 in.)
0.6 mm (0.024 in.)
0.7 mm (0.027 in.)
0.8 mm (0.03 in.)

9Y1210982TRS0115US0

4 REAR AXLE

MECHANISM

CONTENTS

1. STRUCTURE.....	4-M1
-------------------	------

1. STRUCTURE

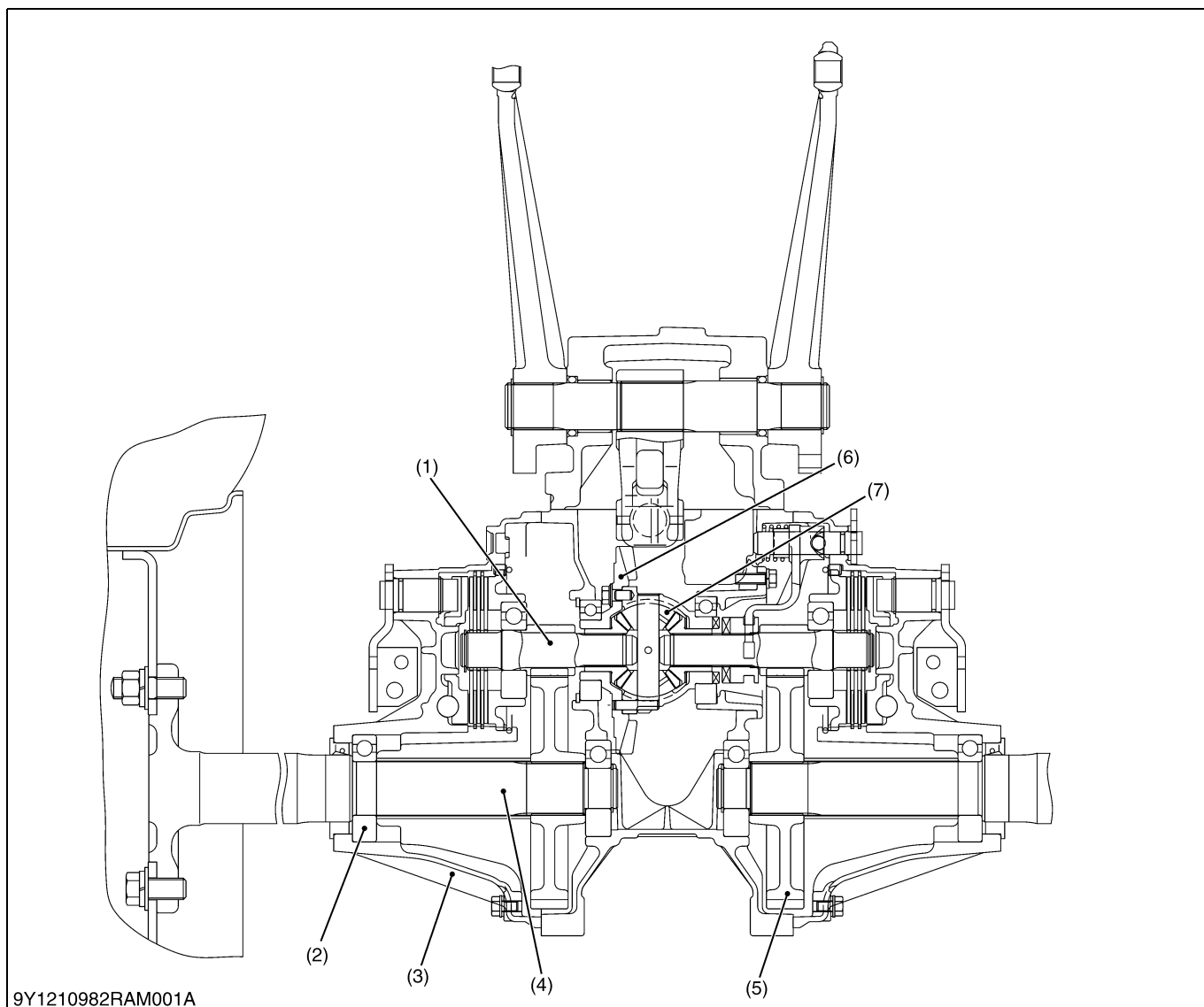

9Y1210982RAM001A

- | | | | |
|-----------------------------|--------------------|-----------------------|-----------------------|
| (1) Differential Gear Shaft | (3) Rear Axle Case | (5) Spur Gear | (7) Differential Gear |
| (2) Ball Bearing | (4) Rear Axle | (6) Spiral Bevel Gear | |

The rear axles are the semi floating type with ball bearing (2) between the rear axle (4) and the rear axle case (3), which supports the rear wheel load as well as transmitting power to the rear wheels.

The differential gears (7) automatically control the revolution of right and left wheels when the rear wheels encounter unequal resistance during turning.

9Y1210982RAM0001US0

SERVICING

CONTENTS

1. TROUBLESHOOTING.....	4-S1
2. TIGHTENING TORQUES.....	4-S2
3. DIASSEMBLING AND SERVICING	4-S3
[1] DIASSEMBLING AND ASSEMBLING.....	4-S3
(1) Separating Rear Axle Case	4-S3
[2] SERVICING.....	4-S6

1. TROUBLESHOOTING

Symptom	Probable Cause and Checking Procedure	Solution	Reference Page
Excessive or Unusual Noise at All Time	1. Improper backlash between differential gear shaft and final reduction gear	Inspect or adjust backlash	3-S63
	2. Bearing worn	Inspect or replace bearing	4-S6
	3. Insufficient or improper type of transmission fluid used	Check transmission oil	G-8
Noise while Turning	1. Brake shaft and gear and internal gear worn or damaged	Replace brake shaft or gear	4-S5

9Y1210982RAS0001US0

2. TIGHTENING TORQUES

Tightening torques of screws, bolts and nuts on the table below are especially specified.
(For general use screws, bolts and nuts: Refer to G-10.)

Item	N·m	kgf·m	lbf·ft
Rear wheel mounting nut and screw [B2050, B2350, B2650]	108 to 126	11.1 to 12.8	79.7 to 92.9
Rear wheel mounting nut [B3150]	167 to 191	17 to 19.5	123 to 141
Rear wheel mounting screw [B3150]	196 to 225	20 to 23	145 to 166
3-point hitch delivery pipe 1 joint bolt	48 to 70	4.9 to 7.1	36 to 51
3-point hitch delivery pipe 2 joint bolt (Front loader valve side)	48 to 70	4.9 to 7.1	36 to 51
3-point hitch delivery pipe 2 joint bolt (Hydraulic cylinder case side)	50 to 60	5.1 to 6.1	37 to 44
Rear axle case mounting screw	40 to 44	4.0 to 4.5	29 to 32

9Y1210982RAS0002US0

3. DIASSEMBLING AND SERVICING

[1] DIASSEMBLING AND ASSEMBLING

(1) Separating Rear Axle Case

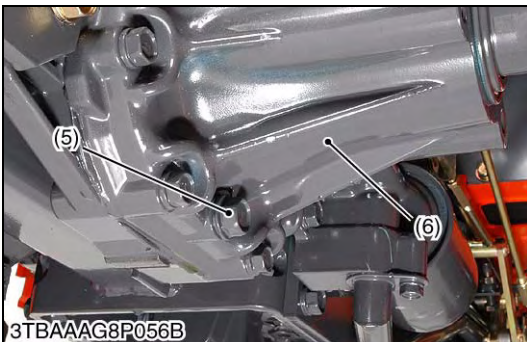
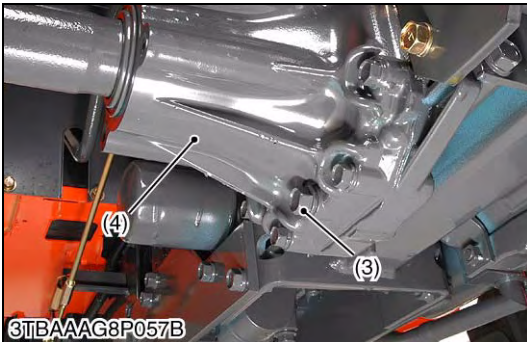
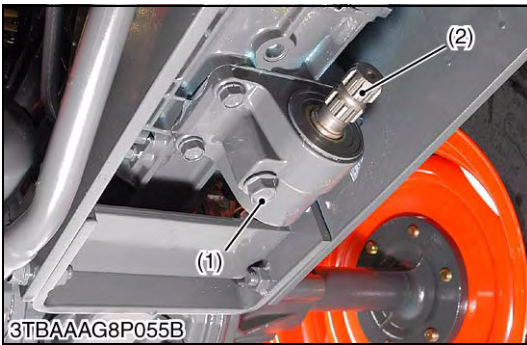

Draining Transmission Fluid

⚠ CAUTION

- Stop the engine before checking and changing the transmission fluid.

1. Place the oil pan under the tractor.
2. Remove the drain plugs (1), (3), (5) at the mid-PTO shaft and at the bottom of the rear axle cases (4), (6).
3. Drain the transmission fluid.
4. After draining the transmission fluid, reinstall the drain plugs (1), (3), (5).

■ IMPORTANT

- Use only KUBOTA UDT oil. Use of other oils may damage the transmission or hydraulic system. Refer to G-8.
- Never work the tractor immediately after changing the transmission oil. Keep the engine at medium speed for a few minutes to prevent damage to the transmission.
- Do not mix different brands oil together.

Transmission fluid capacity	B2050, B2350, B2650 Manual transmission	16.5 L 4.4 U.S.gals 3.6 Imp.gals
	B2350HST B2650HST B3150HST	17 L 4.5 U.S.gals 3.7 Imp.gals

- | | |
|-------------------|---------------------------|
| (1) Drain Plug | (4) Rear Axle Case (L.H.) |
| (2) Mid-PTO Shaft | (5) Drain Plug |
| (3) Drain Plug | (6) Rear Axle Case (R.H.) |

9Y1210982ENS0024US0

Battery Cable

1. Open the bonnet and remove the side cover.
2. Disconnect the battery negative cable (1).

■ NOTE

- When disconnecting the battery cables, disconnect the grounding cable first. When connecting, the positive cable first.

- (1) Battery Negative Cable

9Y1210982RAS0011US0



Rear Wheel

1. Place the disassembling stand under the transmission case.
2. Remove the rear wheel (1).

Tightening torque	Rear wheel mounting nut and screw	B2050 B2350 B2650	108 to 126 N·m 11.1 to 12.8 kgf·m 79.7 to 92.9 lbf·ft
	Rear wheel mounting nut	B3150	167 to 191 N·m 17 to 19.5 kgf·m 123 to 141 lbf·ft
	Rear wheel mounting screw		196 to 225 N·m 20 to 23 kgf·m 145 to 166 lbf·ft

(1) Rear Wheel

9Y1210982RAS0008US0

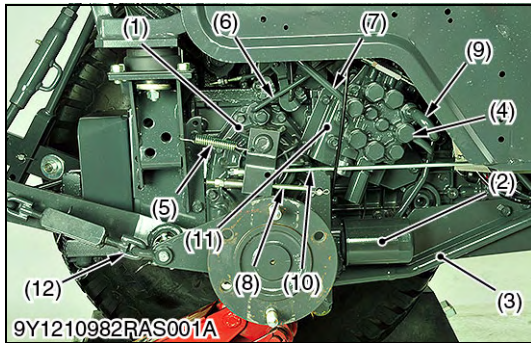

Rear Axle Case (HST Model)

1. Remove the brake rod (10) and parking brake rod (8).
2. Remove the 3-point hitch delivery pipe 2 (7) and return hose (9).
3. Remove the pipe clamps, 3-point hitch delivery pipe 1 (4) and suction pipe (3).
4. Remove the oil filter bracket with oil filter (2).
5. Remove the spring (5).
6. Remove the loader valve assembly (11).
7. Remove the differential lock rod (6) and check chain (12).
8. Remove the rear axle case (1).

(When reassembling)

- Do not damage the O-rings of front loader valve pipes and delivery pipes.
- Apply liquid gasket (Three Bond 1206D or equivalent) to joint face of the rear axle case and differential gear case after eliminating the water and oil.

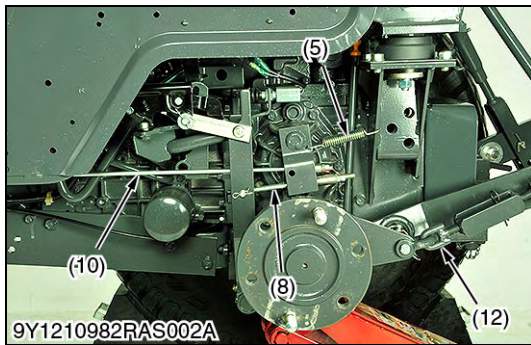

Tightening torque	3-point hitch delivery pipe 1 joint bolt	48 to 70 N·m 4.9 to 7.1 kgf·m 36 to 51 lbf·ft
	3-point hitch delivery pipe 2 joint bolt (Front loader valve side)	48 to 70 N·m 4.9 to 7.1 kgf·m 36 to 51 lbf·ft
	3-point hitch delivery pipe 2 joint bolt (Hydraulic cylinder case side)	50 to 60 N·m 5.1 to 6.1 kgf·m 37 to 44 lbf·ft
	Rear axle case mounting screw	40 to 44 N·m 4.0 to 4.5 kgf·m 29 to 32 lbf·ft

- | | |
|-----------------------------------|-----------------------------------|
| (1) Rear Axle Case | (7) 3-Point Hitch Delivery Pipe 2 |
| (2) Oil Filter | (8) Parking Brake Rod |
| (3) Suction Pipe | (9) Return Hose |
| (4) 3-Point Hitch Delivery Pipe 1 | (10) Brake Rod |
| (5) Spring | (11) Loader Valve Assembly |
| (6) Differential Lock Rod | (12) Check Chain |

9Y1210982RAS0009US0

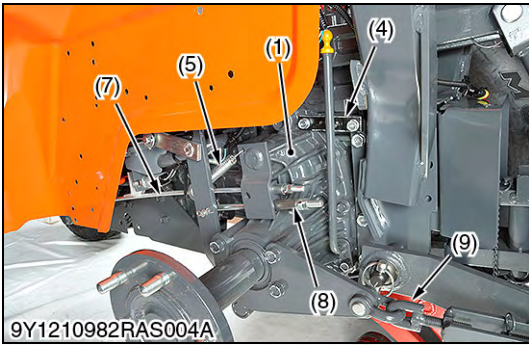
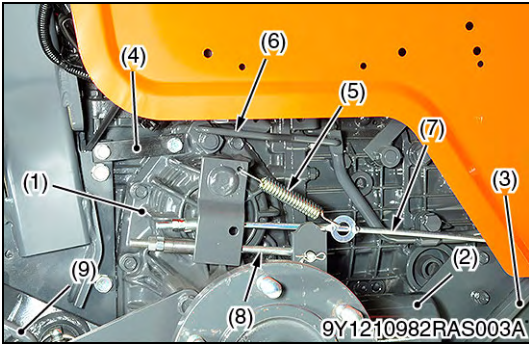

Rear Axle Case (Manual Transmission Model)

1. Remove the brake rod (7) and parking brake rod (8).
2. Remove the oil filter bracket with oil filter (2) and suction pipe (3).
3. Remove the spring (5) and plate (4).
4. Remove the differential lock rod (6) and check chain (9).
5. Remove the rear axle case (1).

(When reassembling)

- Do not damage the O-rings of delivery pipes.
- Apply liquid gasket (Three Bond 1206D or equivalent) to joint face of the rear axle case and differential gear case after eliminating the water and oil.

Tightening torque	Rear axle case mounting screw	40 to 44 N·m 4.0 to 4.5 kgf·m 29 to 32 lbf·ft
-------------------	-------------------------------	---

- | | |
|--------------------|---------------------------|
| (1) Rear Axle Case | (6) Differential Lock Rod |
| (2) Oil Filter | (7) Brake Rod |
| (3) Suction Pipe | (8) Parking Brake Rod |
| (4) Plate | (9) Check Chain |
| (5) Spring | |

9Y1210982RAS0010US0

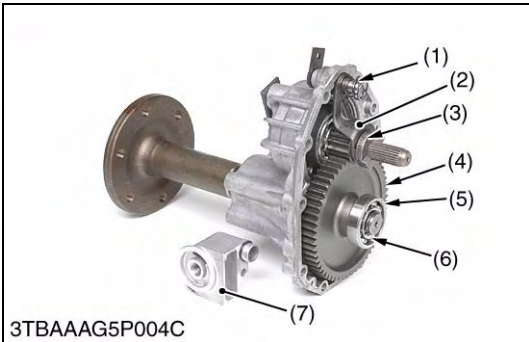

Differential Lock Shift Fork

1. Remove the spring (1).
2. Draw out the differential lock clutch (3) and the differential lock shift fork (2).
3. Remove the external cir-clip (6).
4. Remove the transmission oil filter bracket (7).

- | | |
|----------------------------------|-------------------------------------|
| (1) Spring | (5) Ball Bearing |
| (2) Differential Lock Shift Fork | (6) External Cir-clip |
| (3) Differential Lock Clutch | (7) Transmission Oil Filter Bracket |
| (4) 57T Gear | |

9Y1210982RAS0005US0

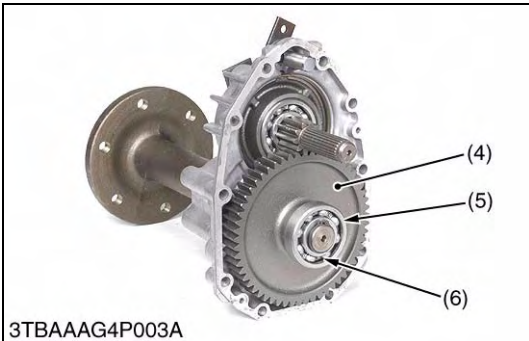

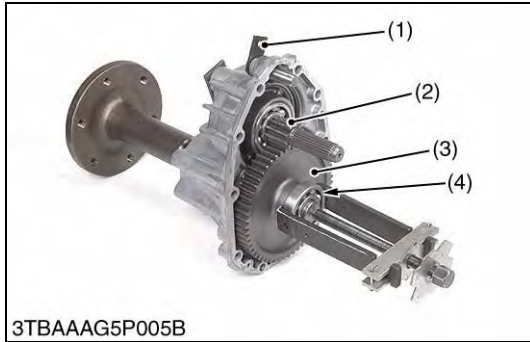

Rear Axle Shaft

1. Remove the fork rod (1).
2. Remove the ball bearing (4) with a puller.
3. Remove the gear (3).
4. Remove the brake shaft assembly (2).
5. Tap out the rear axle shaft (5) with a rubber hammer to the outside.

(When reassembling)

- Tap in the ball bearing to the rear axle case.

- | | |
|--------------------------|---------------------|
| (1) Fork Rod | (5) Rear Axle Shaft |
| (2) Brake Shaft Assembly | (6) Oil Seal |
| (3) 57T Gear | (7) Ball Bearing |
| (4) Ball Bearing | |

9Y1210982RAS0006US0

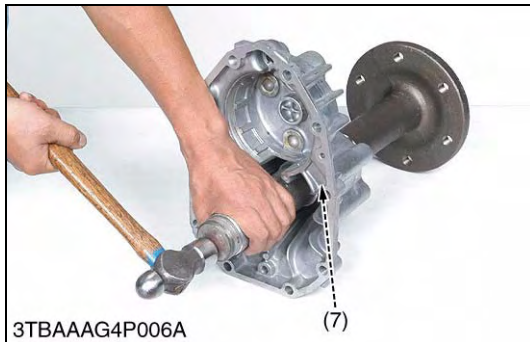
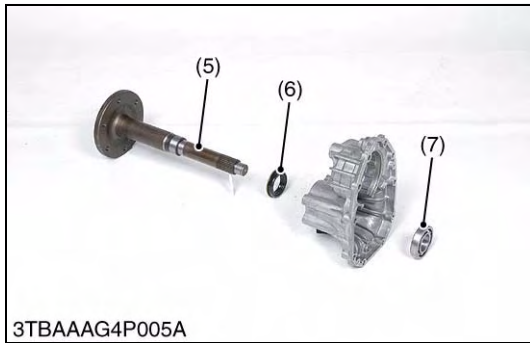
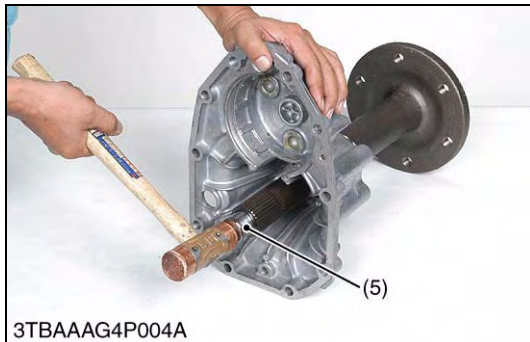

[2] SERVICING



Checking Ball Bearing

1. Hold the inner race, and push and pull the outer race in all directions to check for wear and roughness.
2. Apply transmission fluid to the bearing, and hold the inner race. Then, turn the outer race to check rotation.
3. If there is any problem, replace it.

9Y1210982RAS0007US0

5 BRAKES

MECHANISM

CONTENTS

1. LINKAGE	5-M1
[1] ROPS	5-M1
(1) HST Type	5-M1
(2) Manual Type.....	5-M1
[2] CABIN (HST TYPE).....	5-M2
2. OPERATION.....	5-M3

1. LINKAGE

[1] ROPS

(1) HST Type

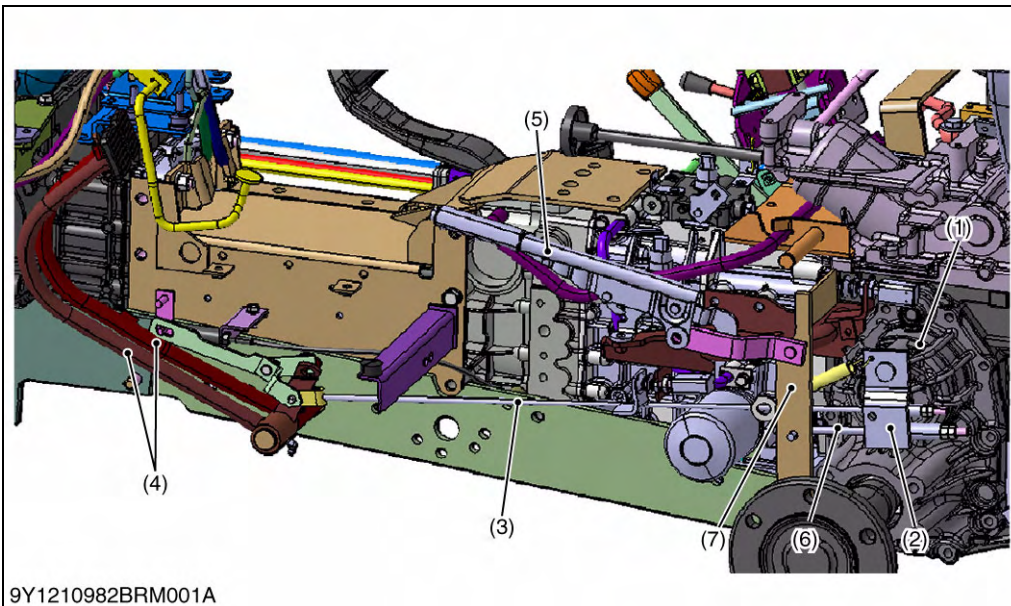

- (1) Rear Axle Case
- (2) Brake Cam Lever
- (3) Brake Rod
- (4) Brake Pedal
- (5) Parking Brake Lever
- (6) Parking Brake Lever Rod
- (7) Parking Brake Lever Arm

9Y1210982BRM001A

Independent mechanical wet disc brakes are used for the right and left traveling brakes. They are operated by the brake pedals through the mechanical linkages and provide stable braking and require little adjustment.

The parking brake is a mechanical type which is designed to actuate the traveling brakes through the linkages. Pulling the parking brake lever (5) results in the same state as the obtained when the brake pedals are depressed. Linkage mechanism of brake is different from parking brake.

9Y1210982BRM0001US0

(2) Manual Type

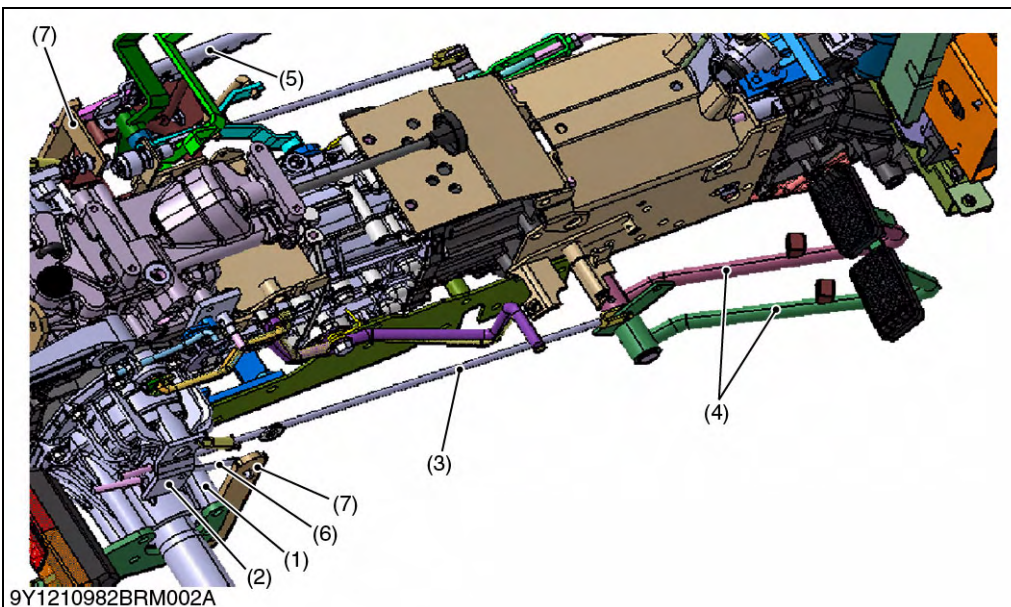

- (1) Rear Axle Case
- (2) Brake Cam Lever
- (3) Brake Rod
- (4) Brake Pedal
- (5) Parking Brake Lever
- (6) Parking Brake Lever Rod
- (7) Parking Brake Lever Arm

9Y1210982BRM002A

Independent mechanical wet disc brakes are used for the right and left traveling brakes. They are operated by the brake pedals through the mechanical linkages and provide stable braking and require little adjustment.

The parking brake is a mechanical type which is designed to actuate the traveling brakes through the linkages. Pulling the parking brake lever (5) results in the same state as the obtained when the brake pedals are depressed. Linkage mechanism of brake is different from parking brake.

9Y1210982BRM0002US0

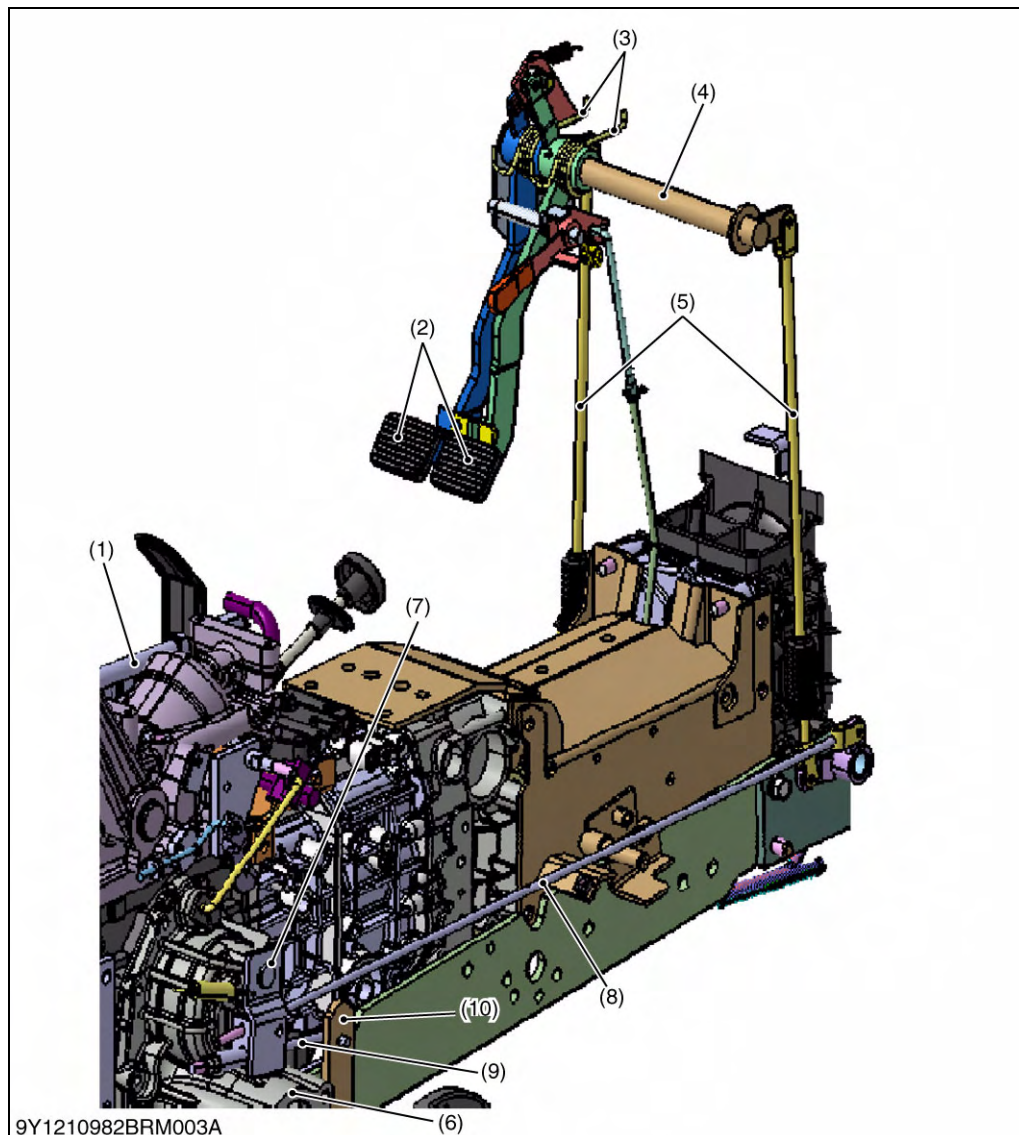
[2] CABIN (HST TYPE)

- (1) Parking Brake Lever
- (2) Brake Pedal
- (3) Spring
- (4) Brake Pedal Shaft
- (5) Brake Pedal Rod
- (6) Rear Axle Case
- (7) Brake Cam Lever
- (8) Brake Rod
- (9) Parking Brake Lever Rod
- (10) Parking Brake Arm

9Y1210982BRM003A

Independent mechanical wet disc brakes are used for the right and left traveling brakes. They are operated by the brake pedals through the mechanical linkages and provide stable braking and require little adjustment.

The parking brake is a mechanical type which is designed to actuate the traveling brakes through the linkages. Pulling the parking brake lever (5) results in the same state as the obtained when the brake pedals are depressed. Linkage mechanism of brake is different from parking brake.

9Y1210982BRM0003US0

2. OPERATION

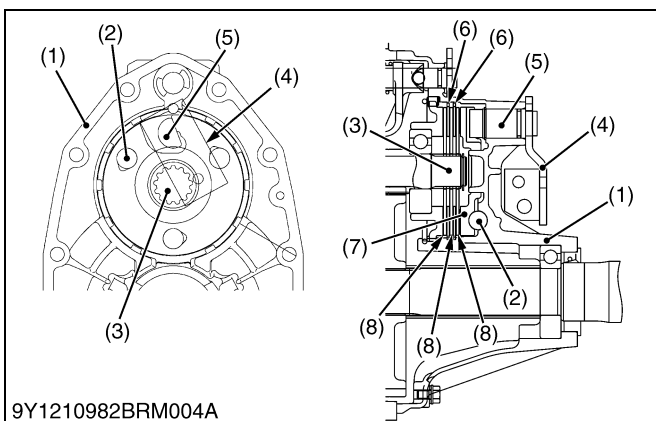

9Y1210982BRM004A

The brake body incorporated in the rear axle case (1) filled with transmission oil and is designed to brake when the brake disc (8) splined with the differential gear shaft (3) is pressed against the cam plate (7) by means of the cam mechanism incorporating steel balls (2).

For greater braking force, three brake discs are provided at the right and left sides respectively, and two friction plates (6) fixed to the rear axle case are arranged between the brake discs.

■ During Braking

When the brake pedal is pressed, the linkage causes the brake cam lever (4) and brake cam (5) to turn into the direction of arrow shown in the above figure.

Therefore, the cam plate (7) also moves to the direction of arrow. At this time, since the cam plate (7) rides on the steel balls (2) set in the grooves of the rear axle case to press the brake disc (8), the differential gear shaft (3) is braked by the frictional force generated by the cam plates (7) and brake discs (8).

- | | |
|--|--------------------|
| (1) Rear Axle Case | (5) Brake Cam |
| (2) Steel Ball | (6) Friction Plate |
| (3) Brake Shaft
(Differential Gear Shaft) | (7) Cam Plate |
| (4) Brake Cam Lever | (8) Brake Disc |

9Y1210982BRM0004US0

SERVICING

CONTENTS

1. TROUBLESHOOTING.....	5-S1
2. SERVICING SPECIFICATIONS.....	5-S2
3. TIGHTENING TORQUES.....	5-S3
4. CHECKING, DISASSEMBLING AND SERVICING.....	5-S4
[1] CHECKING AND ADJUSTING.....	5-S4
[2] DISASSEMBLING AND ASSEMBLING.....	5-S5
(1) Brake Pedal (Cabin HST Model).....	5-S5
(2) Brake Pedal (ROPS Manual Transmission Model).....	5-S7
(3) Brake Pedal (ROPS HST Model).....	5-S7
(4) Parking Brake Lever.....	5-S8
(5) Separating Rear Axle Case.....	5-S8
[3] SERVICING.....	5-S12

1. TROUBLESHOOTING

Symptom	Probable Cause and Checking Procedure	Solution	Reference Page
Uneven Braking Force	1. Brake pedal free travel unevenly adjusted	Check or adjust brake pedal free travel	5-S4
	2. Brake disc worn	Replace brake disc	5-S10
	3. Cam plate warped	Replace cam plate	5-S10
Brake Drags	1. Brake pedal free travel too small	Check or adjust brake pedal free travel	5-S4
	2. Parking brake lever free travel too small	Check or adjust parking brake lever free travel	5-S5
	3. Brake cam rusted	Repair or replace brake cam	5-S11
Poor Braking Force	1. Brake pedal free travel excessive	Check or adjust brake pedal free travel	5-S4
	2. Brake disc worn	Replace brake disc	5-S10
	3. Cam plate warped	Inspect or replace cam plate	5-S12
	4. Brake cam or lever damaged	Repair or replace brake cam or lever	5-S11
	5. Transmission fluid improper	Check transmission oil	G-8

9Y1210982BRS0001US0

2. SERVICING SPECIFICATIONS

Item		Factory Specification	Allowable Limit
Brake Pedal	Free Travel (ROPS)	30 to 40 mm 1.2 to 1.5 in. on the pedal	—
	Free Travel (CABIN)	20 to 30 mm 0.79 to 1.1 in. on the pedal	—
Parking Brake	Free Travel	2 notches	—
Cam Plate and Ball	Height	22.89 to 22.99 mm 0.9012 to 0.9051 in.	22.40 mm 0.8819 in.
Brake Disc	Thickness	3.3 to 3.5 mm 0.130 to 0.137 in.	3.0 mm 0.118 in.
Friction Plate	Thickness	1.92 to 2.08 mm 0.0756 to 0.0818 in.	1.52 mm 0.0598 in.

9Y1210982BRS0002US0

3. TIGHTENING TORQUES

Tightening torques of screws, bolts and nuts on the table below are especially specified.
(For general use screws, bolts and nuts: Refer to G-10.)

Item	N·m	kgf·m	lbf·ft
Steering wheel mounting nut	20 to 40	2.1 to 4.0	15 to 29

9Y1210982BRS0003US0

4. CHECKING, DISASSEMBLING AND SERVICING

[1] CHECKING AND ADJUSTING

Adjusting Brake Pedal Free Travel

CAUTION

- Stop the engine and chock the wheels before checking brake pedal.
- The difference between the right and left pedal free travel must be less than 5 mm (0.2 in.)

1. Release the parking brake.
2. Slightly depress the brake pedals and measure free travel at top of pedal stroke.
3. If the measurement is not within the factory specifications, loosen the lock nut (2) and adjust the brake rod (4) length.
4. Retighten the lock nut (2) securely.
Keep the free travel in the right and left brake pedals equal.

Brake pedal free travel	Factory specification	ROPS	30 to 40 mm 1.2 to 1.5 in. on the pedal
		CABIN	20 to 30 mm 0.79 to 1.1 in. on the pedal

NOTE

- After checking brake pedal free play, be sure to engage the parking brake lever fully and check to see that the brake pedals are securely locked.

- (1) Brake Pedal
- (2) Lock Nut
- (3) Adjust Nut
- (4) Brake Rod

L: Brake Pedal Free Travel

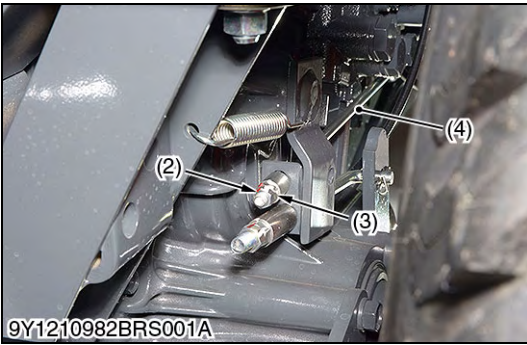
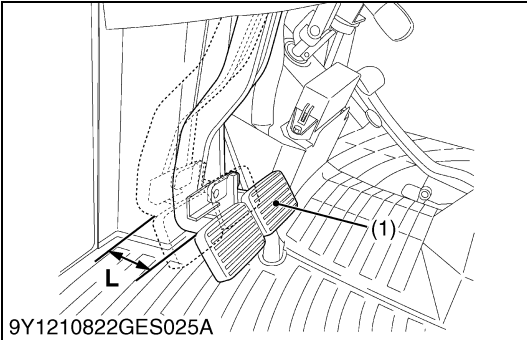

9Y1210982BRS0004US0

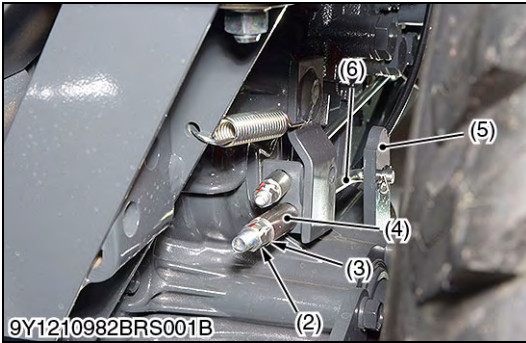
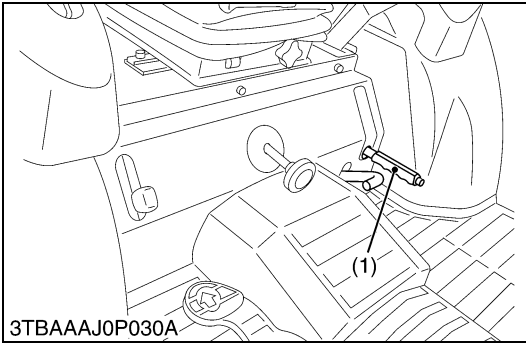

Checking Parking Brake Lever Travel

1. Pull the parking brake lever (1) to the parking position while counting the ratchet sound made by the parking brake lever (1).
2. If the counted ratchet sound is not within the factory specification, adjust the parking brake lever travel.

CAUTION

- Stop the engine and remove the key, and the chock wheels before checking parking brake.

Proper parking brake lever free travel	Factory specification	2 notches (Ratchet sound 2)
--	-----------------------	-----------------------------

(When adjusting)

1. Release the parking brake lever.
2. Be sure to adjust the free travel of the right and left brake pedals.
3. Loosen the lock nuts (2) of the right and left rods (6).
4. Tighten the adjusting nut (3) of the right rod (6) by hand until the collar (4) comes into contact with the arm (5). Make half and one more turn of the nut.
5. Tighten the adjusting nut (3) of the left rod (6) by hand until the collar (4) comes into contact with the arm (5).
6. Tighten up the lock nuts (2) of right and left rods.
7. Make sure the parking brake lever gets locked at the its 3rd notch.

NOTE

- After adjusting the parking brake lever free travel:
 - Right and left parking brake for even braking.
 - With the parking brake released, make sure that the right and left tires do not drag on.

- | | |
|-------------------------|-----------------------|
| (1) Parking Brake Lever | (4) Collar |
| (2) Lock Nut | (5) Parking Brake Arm |
| (3) Adjusting Nut | (6) Parking Brake Rod |

9Y1210982BRS0005US0

[2] DISASSEMBLING AND ASSEMBLING

(1) Brake Pedal (Cabin HST Model)



Battery Cable

1. Open the bonnet.
2. Disconnect the battery negative cable (1).

NOTE

- When disconnecting the battery cables, disconnect the grounding cable first. When connecting, the positive cable first.

- (1) Battery Negative Cable

9Y1210982BRS0017US0



Steering Wheel

1. Remove the steering wheel cap.
2. Remove the steering wheel mounting nut and steering wheel.

(When reassembling)

Tightening torque	Steering wheel mounting nut	20 to 40 N·m 2.1 to 4.0 kgf·m 15 to 29 lbf·ft
-------------------	-----------------------------	---

9Y1210982BRS0018US0



Panel Lower Cover

1. Remove the panel lower cover (1).

- (1) Panel Lower Cover
- (2) Bolt

9Y1210982BRS0019US0

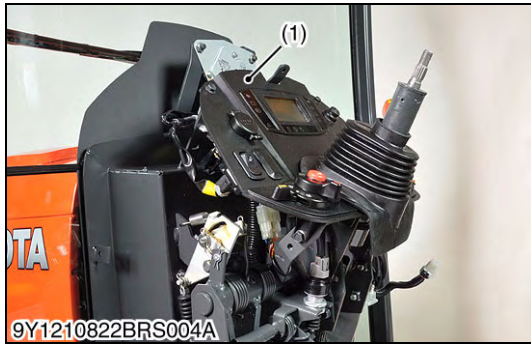

Meter Panel

1. Remove the meter panel mounting bolts and disconnect the each connectors.
2. Remove the meter panel (1).

- (1) Meter Panel

9Y1210982BRS0020US0

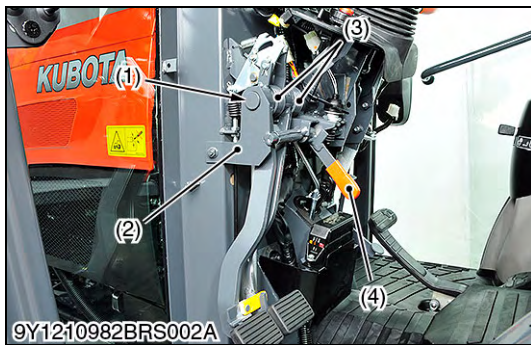

Brake Pedal and Brake Rod

1. Remove the brake pedal shaft support (2) and parking brake lever (4).
2. Remove the brake pedal rods (7), (8).
3. Tap out the spring pin and pull out the brake pedal shaft (1) to the right.
4. Remove the brake pedals (5), (6) and springs (3).

(When reassembling)

- Apply grease to the brake pedal shaft.
- Be sure to adjust the brake pedal free travel and parking brake lever travel.

- (1) Brake Pedal Shaft
- (2) Brake Pedal Shaft Support
- (3) Spring
- (4) Bi-speed Lever
- (5) Brake Pedal LH
- (6) Brake Pedal RH
- (7) Brake Pedal Rod LH
- (8) Brake Pedal Rod RH

9Y1210982BRS0021US0

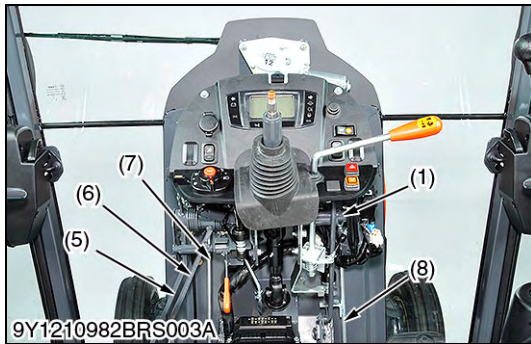

(2) Brake Pedal (ROPS Manual Transmission Model)

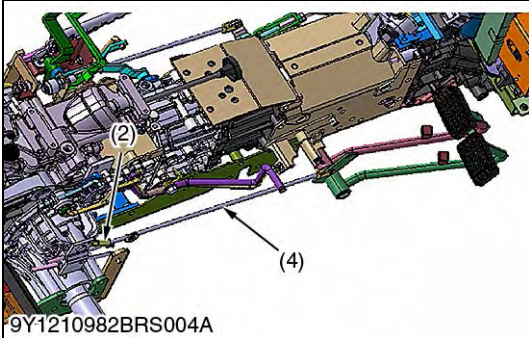
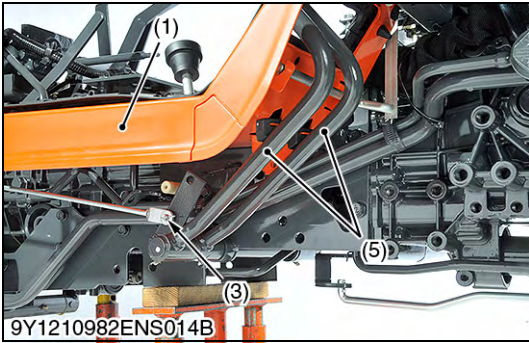

Brake Pedal and Step

1. Remove the right side step (1).
2. Remove the return spring (2).
3. Remove the pin (3) and disconnect brake rod (4) from brake pedal (5).
4. Remove the brake pedal (5).

(When reassembling)

- Apply grease to the brake pedal shaft.
- Be sure to adjust the brake pedal free travel and parking brake lever travel.

- | | |
|-------------------|-----------------|
| (1) Step | (4) Brake Rod |
| (2) Return Spring | (5) Brake Pedal |
| (3) Pin | |

9Y1210982BRS0022US0

(3) Brake Pedal (ROPS HST Model)

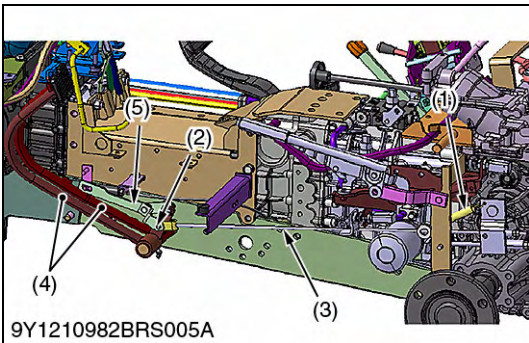

Brake Pedal and Step

1. Remove the left side step.
2. Remove the return spring (1).
3. Remove the pin (2) and disconnect brake rod (3) from brake pedal (4).
4. Disconnect lever (5) from brake pedal (4).
5. Remove the brake pedal (4).

(When reassembling)

- Apply grease to the brake pedal shaft.
- Be sure to adjust the brake pedal free travel and parking brake lever travel.

- | | |
|-------------------|-----------------|
| (1) Return Spring | (4) Brake Pedal |
| (2) Pin | (5) Lever |
| (3) Brake Rod | |

9Y1210982BRS0023US0

(4) Parking Brake Lever

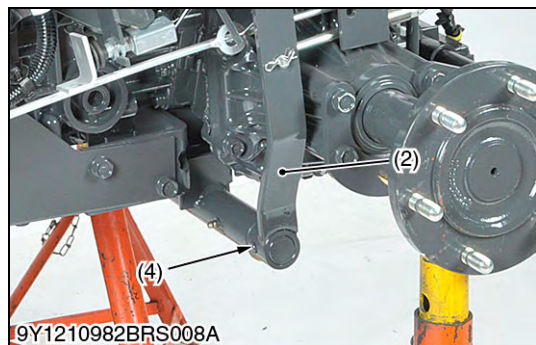
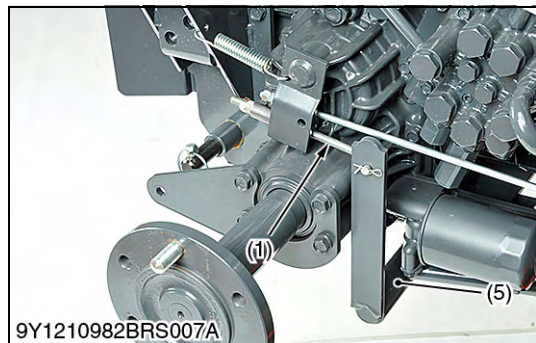
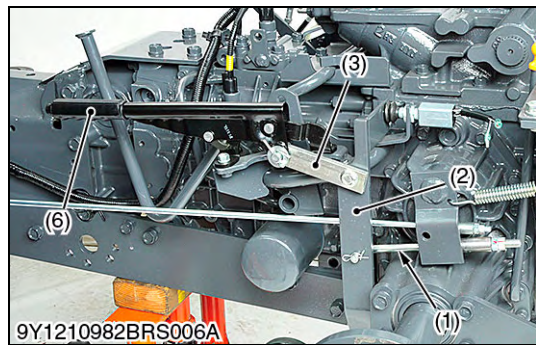

Parking Brake Lever

1. Disconnect the parking brake rod (1) from parking brake arm (2).
2. Disconnect parking brake lever plate (3) from parking brake arm (2).
3. Remove the pin (4), parking brake arm (2) and parking brake shaft (5),
4. Remove the parking brake lever (6) and parking brake lever plate (3).

(When reassembling)

- Apply grease to the brake pedal shaft.
- Be sure to adjust the brake pedal free travel and parking brake lever travel.

- | | |
|-------------------------------|-------------------------|
| (1) Parking Brake Rod | (4) Pin |
| (2) Parking Brake Arm | (5) Parking Brake Shaft |
| (3) Parking Brake Lever Plate | (6) Parking Brake Lever |

9Y1210982BRS0024US0

(5) Separating Rear Axle Case

Draining Transmission Oil

1. See page 3-S16.

9Y1210982BRS0007US0

Rear Axle Case

1. See page 4-S4.

9Y1210982BRS0008US0

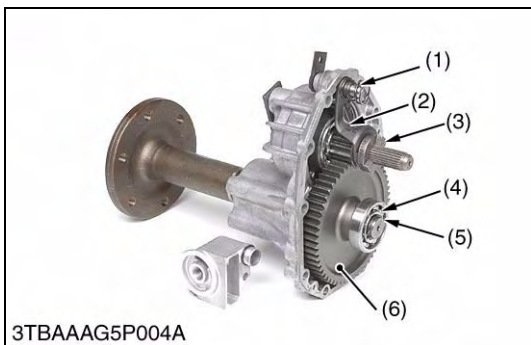

Differential Lock Clutch and Final Gear

1. Remove the spring (1).
2. Remove the differential lock clutch (3) and the differential shift fork (2).
3. Remove the external cir-clip (5).
4. Remove the ball bearing with a puller.
5. Remove the final gear (6).

- | | |
|----------------------------------|-----------------------|
| (1) Spring | (4) Ball Bearing |
| (2) Differential Lock Shift Fork | (5) External Cir-clip |
| (3) Differential Lock Clutch | (6) Final Gear |

9Y1210982BRS0009US0

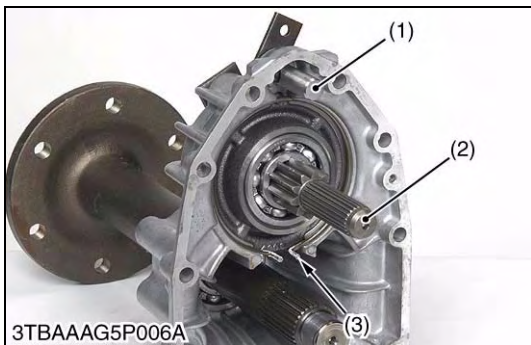
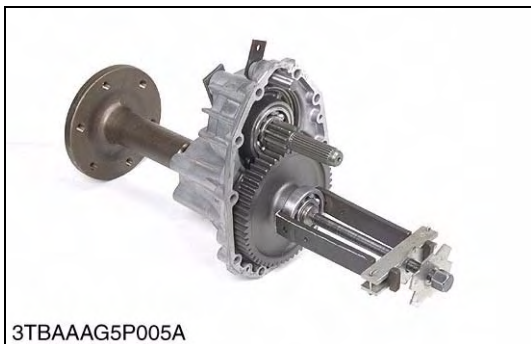

Brake Assembly

1. Remove the differential fork lever (1).
2. Remove the internal snap ring (3).
3. Remove the brake shaft (2) with the brake disks and the brake plates as an assembly.

(When reassembling)

- When installing the internal snap ring (3) to the rear axle case as shown in the picture.
- When installing the bearing holder to the rear axle case, do not forget to install the straight pin (4).

- | | |
|-----------------------------|--------------------|
| (1) Differential Fork Lever | (4) Straight Pin |
| (2) Brake Shaft | (5) Bearing Holder |
| (3) Internal Snap Ring | |

9Y1210982BRS0010US0

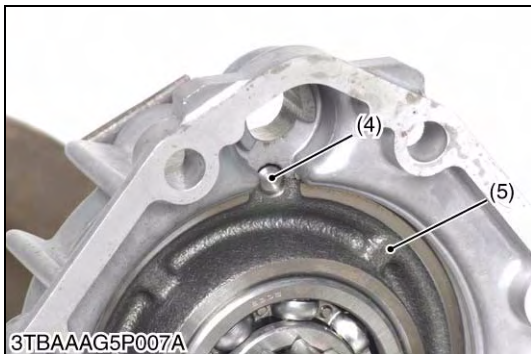

Brake Disks, Brake Plates and Brake Shaft

1. Remove the external cir-clip (6), and remove the brake disks (4) and the brake plates (5).
2. Remove the bearing holder (3) and the ball bearing (2).

(When reassembling)

■ **NOTE**

- Since the length of the brake shaft (L.H.) and the brake shaft (R.H.) are different, don't exchange them.
- Install the brake disks with their holes (7) deviation at less than 1/3 of the total hole area.

- | | |
|--------------------|------------------------|
| (1) Brake Shaft | (6) External Cir-clip |
| (2) Ball Bearing | (7) Hole |
| (3) Bearing Holder | (8) Brake Shaft (L.H.) |
| (4) Brake Disk | (9) Brake Shaft (R.H.) |
| (5) Brake Plate | |

9Y1210982BRS0011US0

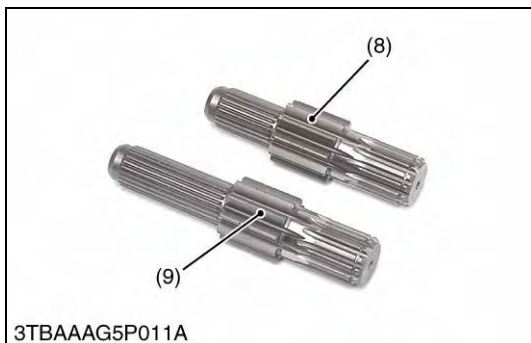
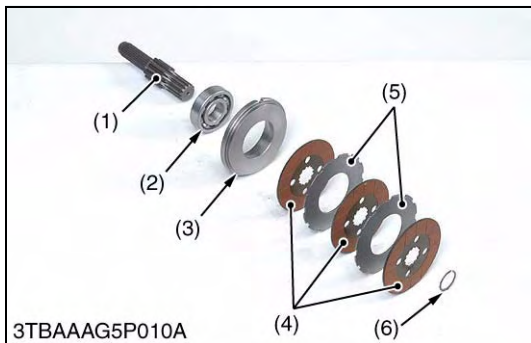
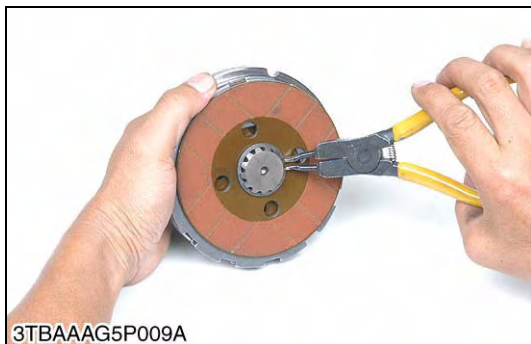
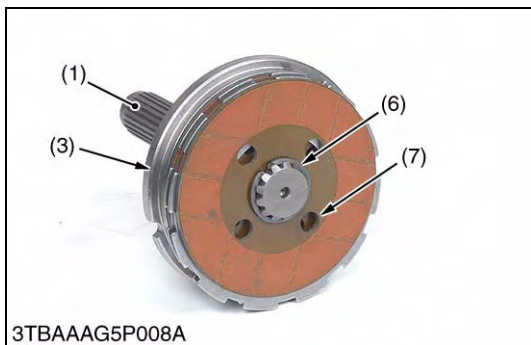

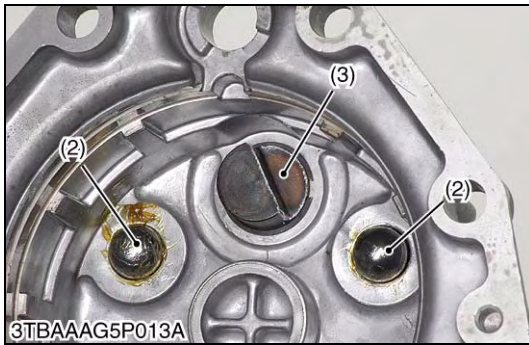
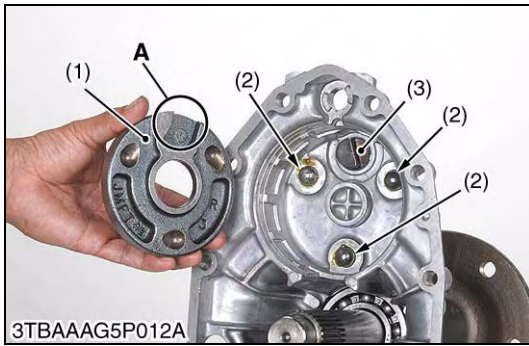

Brake Cam Plate and Brake Cam Lever

1. Remove the brake cam plate (1) and the balls (2).

(When reassembling)

- Apply grease to the balls (2).
- If O-ring (4) is damaged, change it.
- Install the brake cam lever (3) to the brake cam plate (1) securely.
- Move the brake cam lever (3) by hand to check the movement. If the movement is heavy, refine the brake cam plate (1) with emery paper.

- (1) Brake Cam Plate
- (2) Ball
- (3) Brake Cam Lever
- (4) O-ring
- (5) Brake Shaft

A: Portion to the Brake Cam Lever

9Y1210982BRS0012US0

[3] SERVICING



Brake Cam Lever Movement

1. Move the brake cam lever by hand to check the movement.
2. If the movement is heavy, refine the brake cam with emery paper.

9Y1210982BRS0013US0



Cam Plate Flatness and Bearing Holder Wear

1. Place a straightedge of 150 mm (5.91 in.) or more in length on the contacting surface of the cam plate and the bearing holder.
2. Inspect the friction surface of the cam plate and the bearing holder with the straightedge, and determine if a 0.30 mm (0.0118 in.) feeler gauge will fit on the part of wear.
3. If it will fit, resurface the cam plate.

9Y1210982BRS0014US0



Height of Cam Plate and Ball

1. Measure the height of the cam plate with the ball installed.
2. If the measurement is less than the allowable limit, replace the cam plate and balls.
3. Inspect the ball holes of cam plate for uneven wear.
4. If the uneven wear is found, replace it.

Height of cam plate and ball	Factory specification	22.89 to 22.99 mm 0.9012 to 0.9051 in.
	Allowable limit	22.40 mm 0.8819 in.

9Y1210982BRS0015US0



Brake Disc and Friction Plate Wear

1. Measure the brake disc thickness and the friction plate thickness with an outside micrometer.
2. If the thickness is less than the allowable limit, replace it.

Brake disc thickness	Factory specification	3.3 to 3.5 mm 0.130 to 0.137 in.
	Allowable limit	3.0 mm 0.118 in.

Friction plate thickness	Factory specification	1.92 to 2.08 mm 0.0756 to 0.0818 in.
	Allowable limit	1.52 mm 0.0598 in.

9Y1210982BRS0016US0

6 FRONT AXLE

MECHANISM

CONTENTS

1. STRUCTURE.....	6-M1
[1] 4 WHEEL DRIVE MODEL	6-M1

1. STRUCTURE

[1] 4 WHEEL DRIVE MODEL

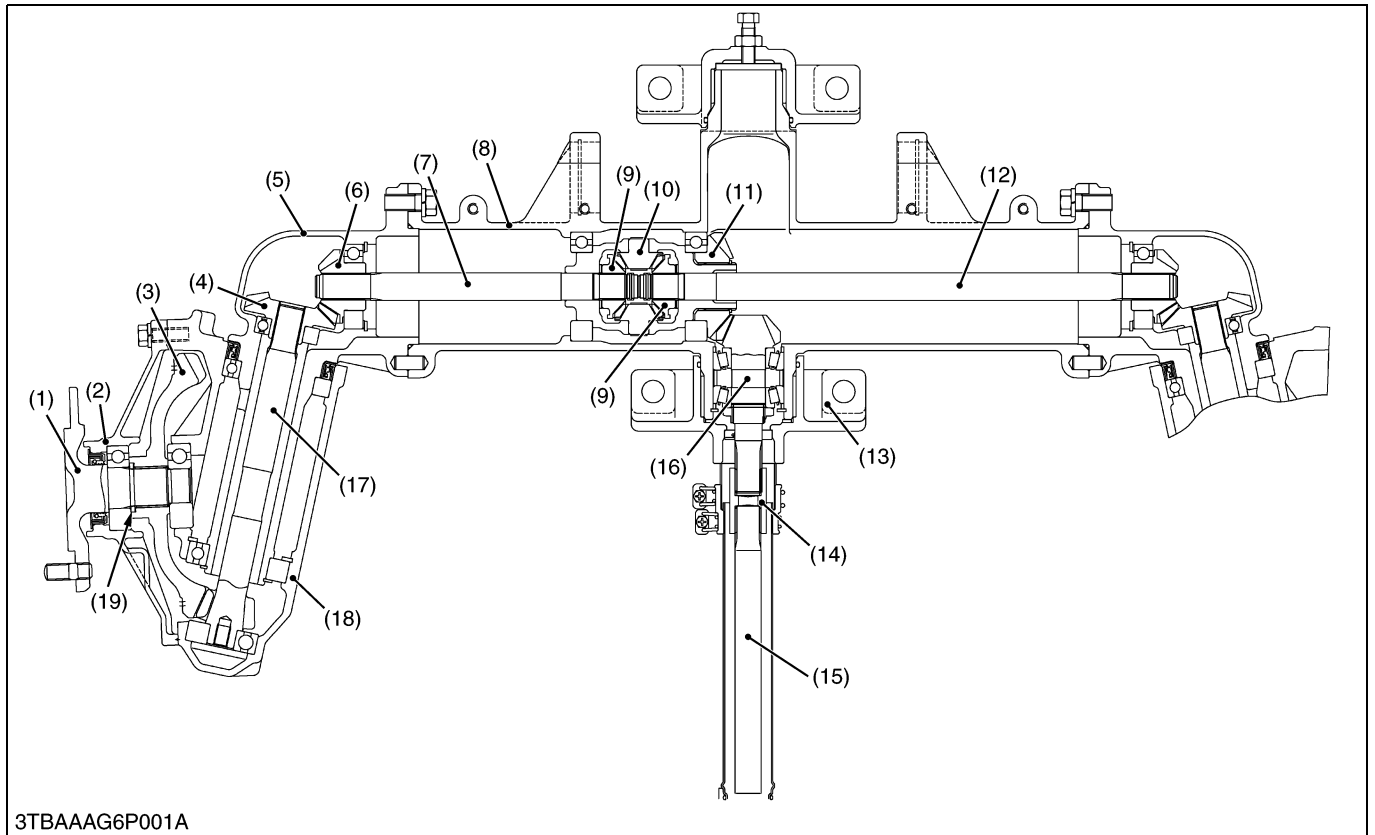

3TBAAAG6P001A

- | | | | |
|---------------------|-------------------------------------|------------------------------------|--------------------------------|
| (1) Axle | (6) Bevel Gear | (11) Spiral Bevel Gear | (16) Spiral Bevel Pinion Shaft |
| (2) Axle Flange | (7) Differential Yoke Shaft, L.H. | (12) Differential Yoke Shaft, R.H. | (17) Bevel Gear Shaft |
| (3) Bevel Gear | (8) Front Axle Case | (13) Front Axle Bracket, Rear | (18) Front Gear Case |
| (4) Bevel Gear | (9) Differential Side Gear (14T) | (14) Coupling | (19) Collar |
| (5) Bevel Gear Case | (10) Differential Pinion Gear (10T) | (15) Propeller Shaft | |

The front axle of the 4WD is constructed as shown above. Power is transmitted from the transmission through the propeller shaft (15) to the spiral bevel pinion shaft (16), then to the spiral bevel gear (11) and to the differential side gear (9).

The power through the differential side gear (9) is transmitted to the differential yoke shaft (7), (12), and to the bevel gear shaft (17) through the bevel gears (4), (6) in the bevel gear case (5).

The revolution is greatly reduced by the bevel gears (3), then the power is transmitted to the axle (1).

The differential system allows each wheel to rotate at a different speed to make turning easier.

9Y1210982FAM0001US0

SERVICING

CONTENTS

1. TROUBLESHOOTING.....	6-S1
2. SERVICING SPECIFICATIONS.....	6-S2
3. TIGHTENING TORQUES.....	6-S3
4. CHECKING, DISASSEMBLING AND SERVICING.....	6-S4
[1] CHECKING AND ADJUSTING.....	6-S4
[2] DISASSEMBLING AND ASSEMBLING.....	6-S5
(1) Separating Front Axle Assembly.....	6-S5
(2) Disassembling Front Axle Assembly.....	6-S6
[3] SERVICING.....	6-S12

1. TROUBLESHOOTING

Symptom	Probable Cause and Checking Procedure	Solution	Reference Page
Front Wheels Wander to Right or Left	1. Tire pressure uneven	Adjust tire pressure	G-56
	2. Improper toe-in adjustment (improper alignment)	Adjust toe-in	6-S4
	3. Clearance between front axle case boss and front axle bracket bushing (front, rear) excessive	Replace bracket bush	6-S15
	4. Front axle rocking force too small	Adjust front axle rocking force	6-S4
	5. Tie-rod end loose	Tighten tie-rod slotted nut	6-S6
Front Wheels Can Not Be Driven	1. Front wheel driving gears in front axle gear case broken	Replace drive gear (front axle gear case side)	6-S7
	2. Front wheel drive gears in transmission broken	Replace drive gear (transmission side)	3-S47
	3. Front differential gear broken	Replace front differential gear	6-S11
Noise	1. Gear backlash excessive	Inspect or adjust backlash	6-S13
	2. Oil insufficient	Check front axle case oil	6-S5
	3. Bearings damaged or broken	Replace bearing	6-S11
	4. Gears damaged or broken	Replace gear	6-S11
	5. Spiral bevel pinion shaft turning torque improper	Inspect or repair spiral bevel pinion	6-S12

9Y1210982FAS0001US0

2. SERVICING SPECIFICATIONS

Item		Factory Specification	Allowable Limit
Front Wheel Alignment	Toe-in	0 to 10 mm 0 to 0.39 in.	–
Front Axle	Rocking Force	50.0 to 100.0 N 5.1 to 10.2 kgf 12.8 to 22.4 lbf	–
Differential Pinion to Differential Case	Clearance	0.032 to 0.068 mm 0.0013 to 0.0026 in.	0.2 mm 0.008 in.
• Differential Case Bore	I.D.	15.000 to 15.018 mm 0.59056 to 0.59125 in.	–
• Differential Pinion	O.D.	14.9509 to 14.968 mm 0.58859 to 0.58829 in.	–
Yoke Shaft to Differential Case	Clearance	0.020 to 0.051 mm 0.00079 to 0.0020 in.	0.2 mm 0.008 in.
• Differential Case Bore	I.D.	20.000 to 20.018 mm 0.78741 to 0.78811 in.	–
• Yoke Shaft	O.D.	19.967 to 19.980 mm 0.78611 to 0.78661 in.	–
Spiral Bevel Pinion Shaft	Turning Torque	0.8 to 1.0 N·m 0.08 to 0.10 kgf·m 0.59 to 0.73 lbf·ft	–
Spiral Bevel Pinion Shaft to Spiral Bevel Gear	Backlash	0.10 to 0.30 mm 0.0040 to 0.011 in.	–
Bevel Gear to 16T Bevel Gear	Backlash	0.10 to 0.30 mm 0.0040 to 0.011 in.	–
Front Axle Case Boss to Bracket Bushing (Front)	Clearance	0.125 to 0.285 mm 0.00493 to 0.0112 in.	0.45 mm 0.018 in.
• Front Axle Case Boss	O.D.	54.94 to 54.97 mm 2.163 to 2.164 in.	–
• Bracket Bushing	I.D.	55.095 to 55.225 mm 2.1691 to 2.1742 in.	–
Front Axle Case Boss to Bracket Bushing (Rear)	Clearance	0.120 to 0.300 mm 0.00473 to 0.0118 in.	0.45 mm 0.018 in.
• Front Axle Case Boss	O.D.	65.005 to 65.035 mm 2.5593 to 2.5604 in.	–
• Bracket Bushing	I.D.	65.155 to 65.305 mm 2.5652 to 2.5710 in.	–

9Y1210982FAS0002US0

3. TIGHTENING TORQUES

Tightening torques of screws, bolts and nuts on the table below are especially specified.
(For general use screws, bolts and nuts: See page G-10.)

Item	N·m	kgf·m	lbf·ft
Front wheel mounting bolt and nut	77.0 to 90.0	7.9 to 9.2	57.0 to 67.0
Delivery hose retaining nut	24 to 28	2.5 to 2.9	17.7 to 20.7
Front axle holder mounting bolt	200 to 230	20.4 to 23.5	147.5 to 169.6
Tie-rod slotted nut	18 to 35	1.8 to 3.5	14 to 25
Tie-rod joint	74 to 84	7.5 to 8.6	54.4 to 61.9
Bevel gear case mounting screw	77.5 to 90.1	7.9 to 9.2	57.1 to 66.5
Axle flange mounting bolt	48.1 to 55.9	4.9 to 5.7	35.5 to 41.2

9Y1210982FAS0003US0

4. CHECKING, DISASSEMBLING AND SERVICING

[1] CHECKING AND ADJUSTING

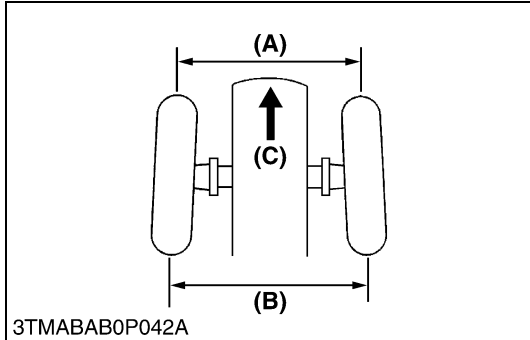

Toe-in

1. Inflate the tires to the specified pressure.
2. Turn the front wheels straight ahead.
3. Measure the toe-in ((B) - (A)).
4. If the measurement is not within the factory specifications, adjust the tie-rod length.

Toe-in (B) - (A)	Factory specification	0 to 10 mm 0 to 0.39 in.
------------------	-----------------------	-----------------------------

(A) Wheel to Wheel Distance at front (C) Front
(B) Wheel to Wheel Distance at rear

9Y1210982FAS0004US0

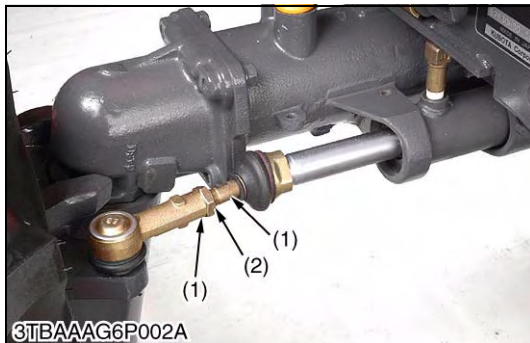

Toe-in Adjusting

1. Loosen the lock nut (2).
2. Turn the tie-rod end (1) to adjust the rod length until the proper toe-in measurement is obtained.
3. Retighten the lock nut (2).

(1) Tie-rod End (2) Lock Nut

9Y1210982FAS0005US0

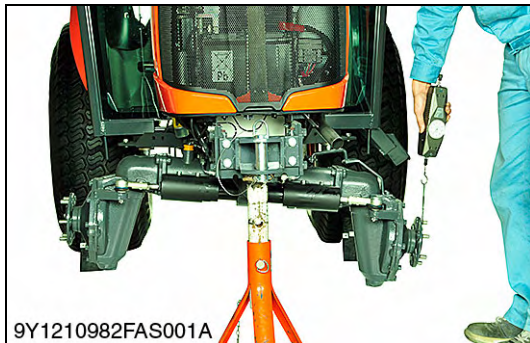

Front Axle Rocking Force

1. Jack up the front side of tractor.
2. Set a spring balance to the front axle flange.
3. Measure the front axle rocking force.
4. If the measurement is not within the factory specifications, adjust with the adjusting screw (2). After applying liquid gasket (Three Bond 1206D or equivalent) to the thread portion of the adjusting screw (2) to prevent front axle oil from leaking out of the front axle holder (3).
5. Tighten the lock nut (1) firmly.

Front axle rocking force	Factory specification	50.0 to 100.0 N 5.1 to 10.2 kgf 12.8 to 22.4 lbf
--------------------------	-----------------------	--

(1) Lock Nut
(2) Adjusting Screw
(3) Holder
(4) Thrust Collar
(5) Front Axle Case

A: Thread Portion

9Y1210982FAS0006US0

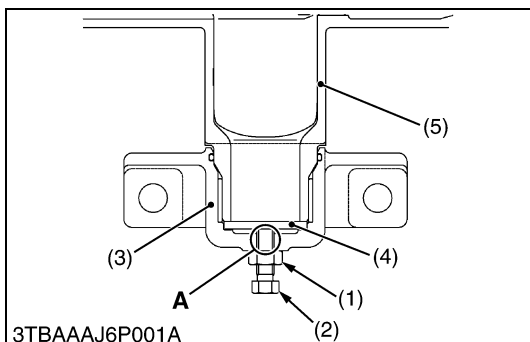
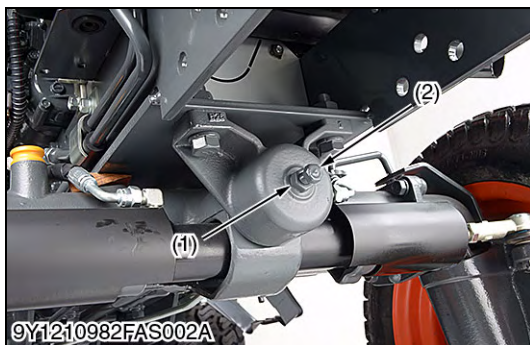

[2] DISASSEMBLING AND ASSEMBLING

(1) Separating Front Axle Assembly

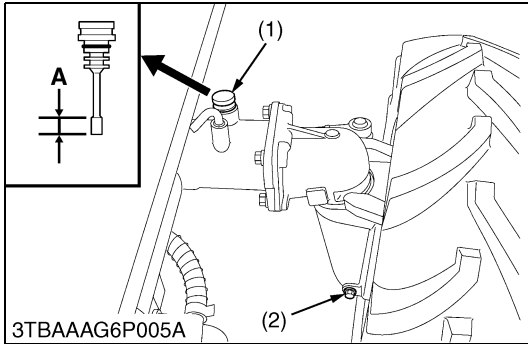

Draining Front Axle Case Oil

1. Place the oil pans underneath the front axle case.
2. Remove the both right and left hand side drain plugs (2) and filling plug (1) to drain the front axle case oil.
3. After draining, reinstall the drain plugs (2).
4. Fill with new oil up to the upper notch on the dipstick.

NOTE

- After ten minutes, check the oil level again, add oil to prescribed level.
- Use KUBOTA SUPER UDT fluid or SAE 80, 90 gear oil. Refer to G-8.

Front axle case oil capacity	B2050, B2350, B2650	3.5 L 3.7 U.S.qts 3.1 Imp.qts
	B3150	4.7 L 5.0 U.S.qts 4.1 Imp.qts

- (1) Filling Plug with Dipstick
(2) Drain Plug

A: Oil level is acceptable within this range

9Y1210982FAS0007US0

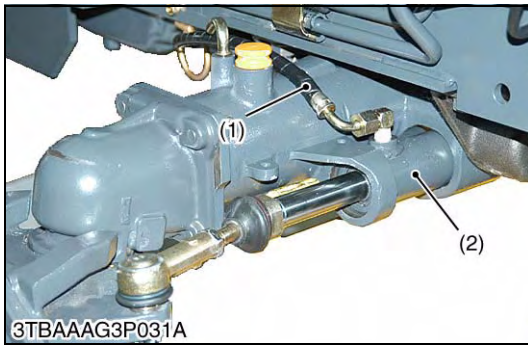

Front Wheels and Steering Cylinder Hoses

1. Disconnect the delivery hoses (1), (3).
2. Lift up the tractor front side.
3. Slide the front cover (4).
4. Remove the front wheels.

NOTE

- After disconnecting the delivery hoses, do not steer the front axle so that the steering oil may come out from the delivery hoses.

IMPORTANT

- Connect the delivery hoses to the original position.

(When reassembling)

- Be sure to assemble the delivery hose R.H. and L.H. as shown in figure.

(Bleeding air in power steering circuit)

- Start the engine.
- Turn the steering wheel slowly in bolt directions all the way alternately several times, and stop the engine.

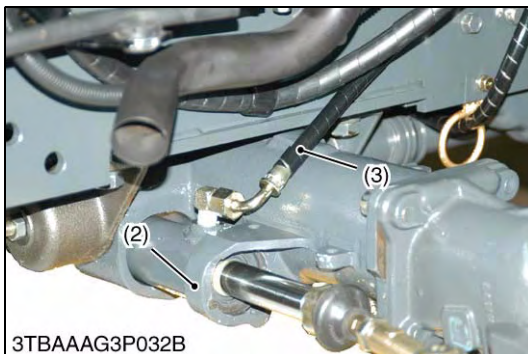

Tightening torque	Front wheel mounting bolt and nut	77.0 to 90.0 N·m 7.9 to 9.2 kgf·m 57.0 to 67.0 lbf·ft
	Delivery hose retaining nut	24 to 28 N·m 2.5 to 2.9 kgf·m 17.7 to 20.7 lbf·ft

- (1) Delivery Hose (R.H.)
(2) Steering Cylinder

- (3) Delivery Hose (L.H.)
(4) Front Cover

9Y1210982FAS0008US0

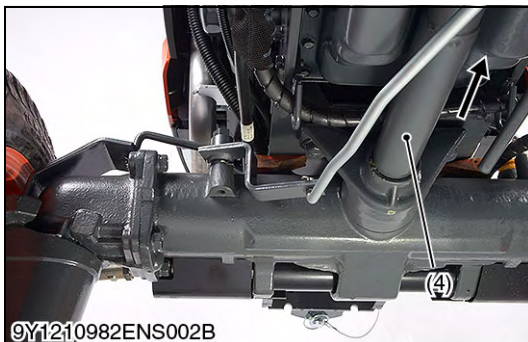

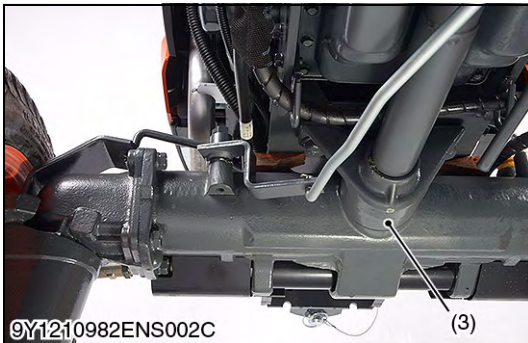
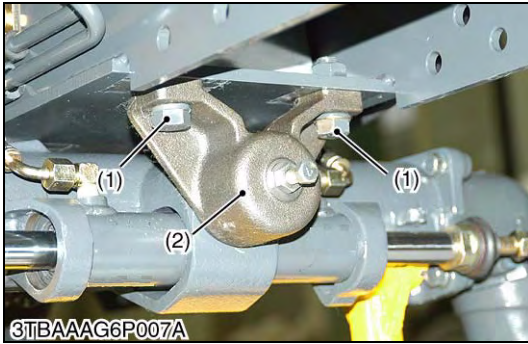

Front Axle Holder and Front Axle

1. Place the disassembling stand under the front axle.
2. Remove the front axle holder mounting bolts (1).
3. Separate the front axle holders (2), (3).
4. Separate the front axle from the front axle frame.

(When reassembling)

- Slide the coupling and the front cover to the front drive shaft.
- Align the front axle holders to the front axle frame, and align the coupling to the bevel pinion shaft spline.

Tightening torque	Front axle holder mounting bolt	200 to 230 N·m 20.4 to 23.5 kgf·m 147.5 to 169.6 lbf·ft
-------------------	---------------------------------	---

- (1) Front Axle Holder Mounting Bolt (3) Front Axle Holder (Rear)
 (2) Front Axle Holder (Front)

9Y1210982FAS0009US0

(2) Disassembling Front Axle Assembly

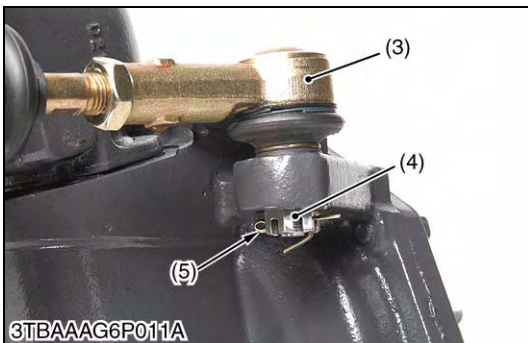
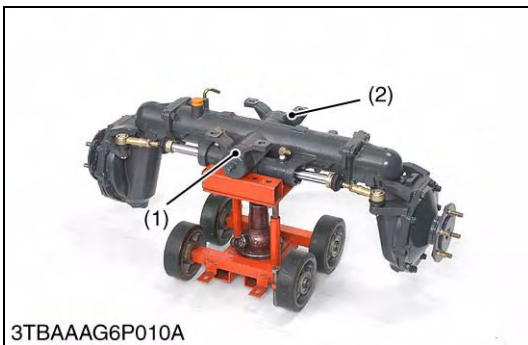

Front Axle Brackets and Tie-rod Ends

1. Remove the slotted nut (4) and remove the tie-rod end (3).
2. Remove the front axle brackets (1), (2).

(When reassembling)

- Apply grease to the thrust collar of front axle bracket.
- Apply grease to the O-ring and take care not to damage it.
- After tightening the slotted nut, install cotter pin as shown in the figure.

Tightening torque	Tie-rod slotted nut	18 to 35 N·m 1.8 to 3.5 kgf·m 14 to 25 lbf·ft
	Tie-rod joint	74 to 84 N·m 7.5 to 8.6 kgf·m 54.4 to 61.9 lbf·ft

- (1) Front Axle Bracket (Front) (4) Slotted Nut
 (2) Front Axle Bracket (Rear) (5) Cotter Pin
 (3) Tie-rod End

9Y1210982FAS0010US0

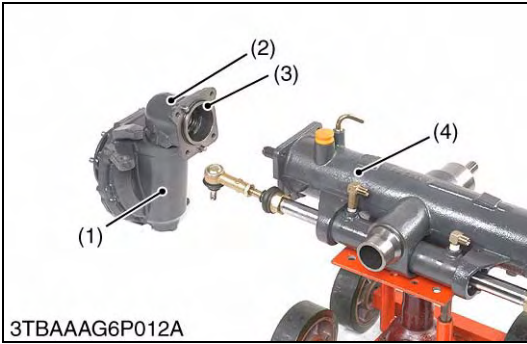

Bevel Gear Case

1. Remove the bevel gear case mounting screws.
2. Remove the bevel gear case (2) and front gear case (1) as a unit from the front axle case (4).

(When reassembling)

- Apply grease to the O-ring (3) and take care not to damage it.
- Do not interchange right and left bevel gear case assemblies and right and left gear case assemblies.

Tightening torque	Bevel gear case mounting screw	77.5 to 90.1 N·m 7.9 to 9.2 kgf·m 57.1 to 66.5 lbf·ft
-------------------	--------------------------------	---

- (1) Front Gear Case (2) Bevel Gear Case (3) O-ring (4) Front Axle Case

9Y1210982FAS0011US0

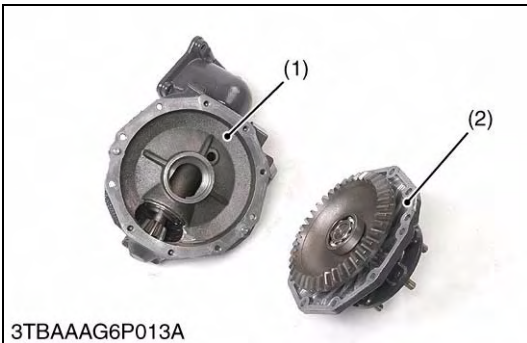

Front Gear Case and Axle Flange

1. Remove the axle flange mounting bolts.
2. Remove the axle flange (2).

(When reassembling)

- Apply liquid gasket (Three Bond 1206D or equivalent) to joint face of the axle flange (2) and the front gear case (1) after eliminating the water, oil and stuck liquid gasket.
- Tighten the axle flange bolts and nuts diagonally in several steps.

Tightening torque	Axle flange mounting bolt	48.1 to 55.9 N·m 4.9 to 5.7 kgf·m 35.5 to 41.2 lbf·ft
-------------------	---------------------------	---

- (1) Front Gear Case (2) Axle Flange **A: Portion to apply liquid gasket**

9Y1210982FAS0012US0

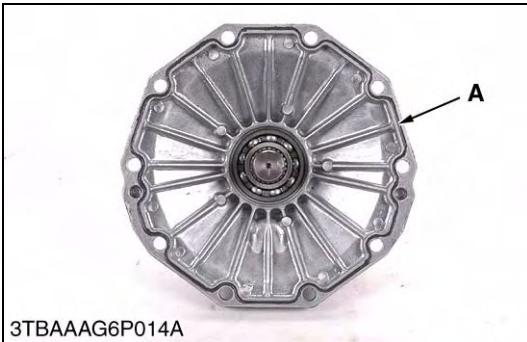

Bevel Gear Shaft and Bevel Gear Case Oil Seal

1. Remove the external cir-clip (3).
2. Remove the bevel gear case (6) from the front gear case (7).
3. Remove the oil seal (9).
4. Remove the ball bearing (8).
5. Remove the internal cir-clip (5) and remove the ball bearing (4).
6. Remove the bevel gear shaft (2) with the bearing.

(When reassembling)

- Install the oil seal (9) of the bevel gear case, noting its direction as shown in the figure.

- | | |
|-----------------------|------------------------------|
| (1) Axle Flange | (6) Bevel Gear Case |
| (2) Bevel Gear Shaft | (7) Front Gear Case |
| (3) External Cir-clip | (8) Ball Bearing |
| (4) Ball Bearing | (9) Bevel Gear Case Oil Seal |
| (5) Internal Cir-clip | |

9Y1210982FAS0013US0

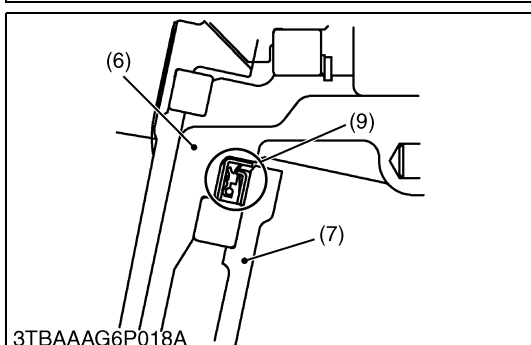
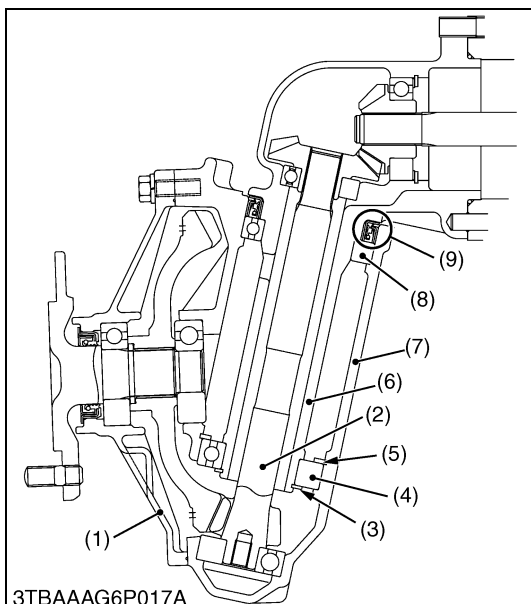
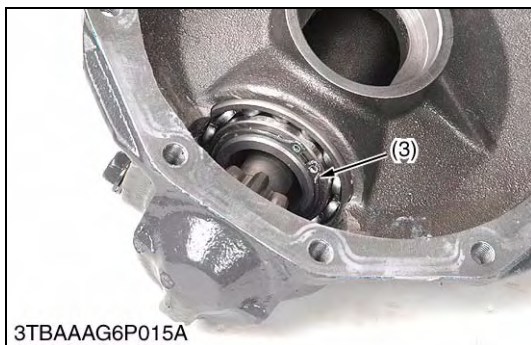

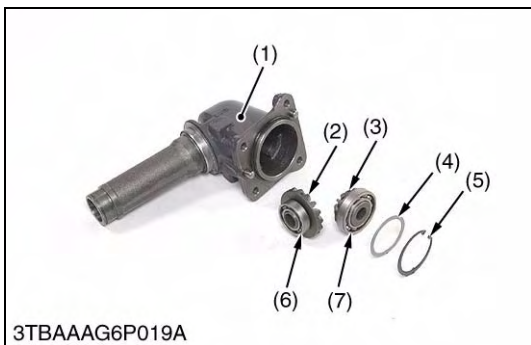

Bevel Gear Case Gears

1. Remove the internal snap ring (5).
2. Remove the bevel gears (3), (2) with ball bearings (7), (6) and shims (4).

(When reassembling)

- Install the shim (4) to their original position.

(Reference)

- Thickness of adjusting shims:
 - 1.0 mm (0.039 in.)
 - 0.8 mm (0.031 in.)
 - 1.2 mm (0.047 in.)
 - 1.4 mm (0.055 in.)

- | | |
|---------------------|-----------------------|
| (1) Bevel Gear Case | (4) Shim |
| (2) Bevel Gear | (5) Internal Cir-clip |
| (3) Bevel Gear | (6) Ball Bearing |
| | (7) Ball Bearing |

9Y1210982FAS0014US0

Axle

1. Remove the bearing (1).
2. Remove the bevel gear (2).
3. Remove the collar (3).
4. Tap out the axle (4).

(When reassembling)

- Install the oil seal (7) of axle flange (6), noting its direction as shown in the figure.
- Install the shims (8) to their original position.

(Reference)

- Thickness of adjusting shims:

[B2050, B2350, B2650]

0.8 mm (0.03 in.): Parts No. 6C040-5714-0

1.0 mm (0.04 in.): Parts No. 6C040-5713-0

1.2 mm (0.05 in.): Parts No. 6C040-5715-0

1.4 mm (0.06 in.): Parts No. 6C040-5716-0

[B3150]

0.2 mm (0.008 in.): Parts No. 66621-1524-0

0.3 mm (0.01 in.): Parts No. 67211-1499-0

- | | |
|------------------|------------------|
| (1) Ball Bearing | (5) Ball Bearing |
| (2) Bevel Gear | (6) Axle Flange |
| (3) Collar | (7) Oil Seal |
| (4) Axle | (8) Shim |

9Y1210982FAS0015US0

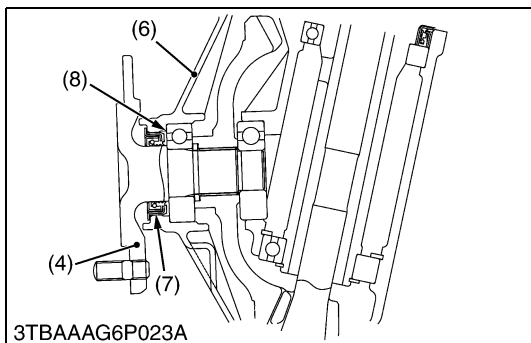
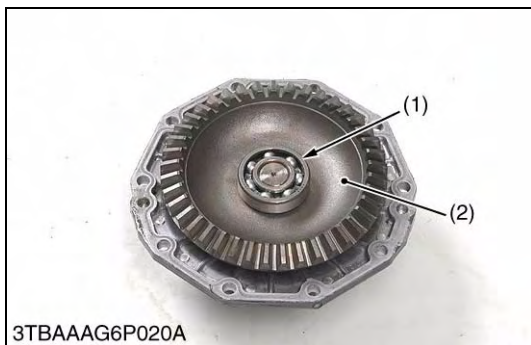

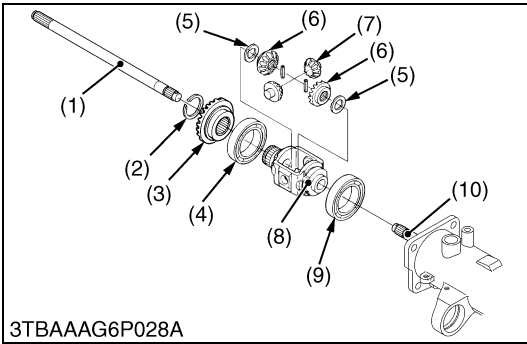
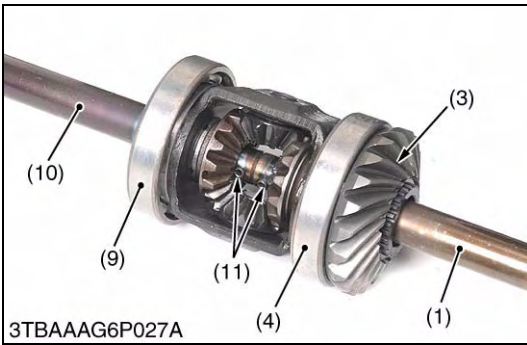
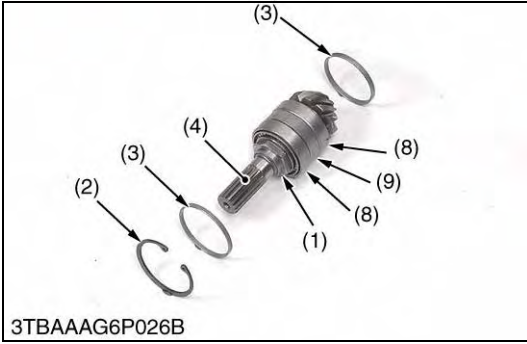
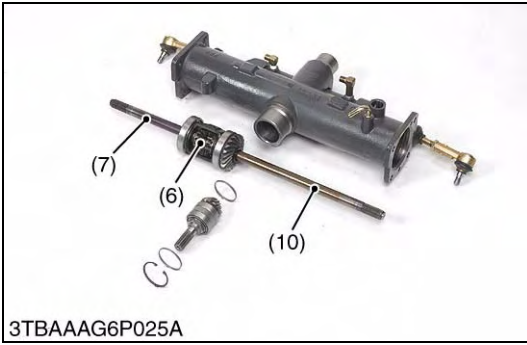
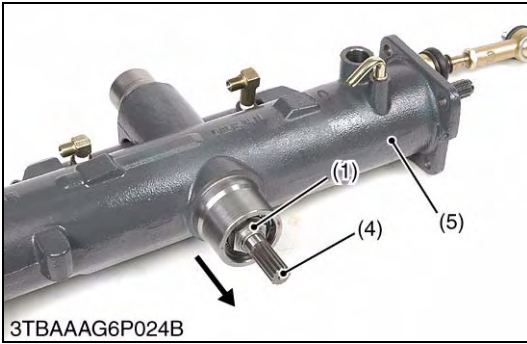

Spiral Bevel Pinion Shaft and Differential Gear Assembly

1. Remove the oil seal from the front axle case (5).
2. Remove the internal cir-clip (2) and the collar (3).
3. Tap out the spiral bevel pinion shaft (4) to the rear side.
4. Remove the differential gear assembly (6) from the right side of the front axle case.
5. Remove the nut (1) from the spiral bevel pinion shaft (4).
6. Remove the taper roller bearings (8).

(When reassembling)

- Replace the oil seal and the nut (1) with new one.
- Apply grease to the oil seal.
- Tighten up the nut (1) until the turning torque of the spiral bevel pinion shaft reaches the factory specifications. (See page 6-S12.)
- Install the same shims and collars before they are removed.
- Install the taper roller bearing correctly, noting their direction, and apply gear oil to them.
- Stake the lock nut firmly.

- | | |
|-------------------------------|-------------------------------------|
| (1) Nut | (6) Differential Gear Assembly |
| (2) Internal Cir-clip | (7) Differential Yoke Shaft (L.H.) |
| (3) Collar | (8) Taper Roller Bearing |
| (4) Spiral Bevel Pinion Shaft | (9) Collar |
| (5) Front axle Case | (10) Differential Yoke Shaft (R.H.) |

9Y1210982FAS0016US0

Differential Gear

1. Remove the external cir-clip (2) from the differential case (8).
2. Tap out the spring pins (11) from the differential yoke shafts (1), (10).
3. Remove the differential yoke shafts (1), (10) from the differential case (8).
4. Remove the bevel gears (6) and the collars (5) from the differential case (8).
5. Remove the spiral bevel gear (3) and the ball bearings (4) from the differential case (8).

NOTE

- **Arrange the parts to know their original position.**

(When reassembling)

- Apply molybdenum disulfide (Three Bond 1901 or equivalent) to the inner circumferential surface of the differential bevel gears (6) and differential pinion (7).

- | | |
|------------------------------------|-------------------------------------|
| (1) Differential Yoke Shaft (R.H.) | (7) Differential Pinion |
| (2) External Cir-clip | (8) Differential Case |
| (3) Spiral Bevel Gear | (9) Ball Bearing |
| (4) Ball Bearing | (10) Differential Yoke Shaft (L.H.) |
| (5) Collar | (11) Spring Pin |
| (6) Bevel Gear | |

9Y1210982FAS0017US0

[3] SERVICING

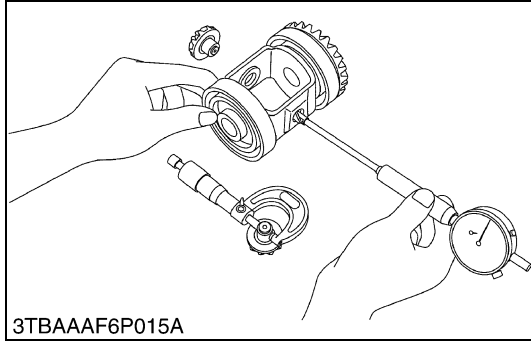

Clearance between Differential Case and Differential Pinion

1. Measure the differential pinion boss O.D. with an outside micrometer.
2. Measure the differential case bore I.D. with a cylinder gauge, and calculate the clearance.
3. If the clearance exceeds the allowable limit, replace damage parts.

Clearance between differential case and differential pinion	Factory specification	0.032 to 0.068 mm 0.0013 to 0.0026 in.
	Allowable limit	0.2 mm 0.008 in.

Differential case bore I.D.	Factory specification	15.000 to 15.018 mm 0.59056 to 0.59125 in.
Differential pinion O.D.	Factory specification	14.9509 to 14.968 mm 0.58859 to 0.58829 in.

9Y1210982FAS0018US0

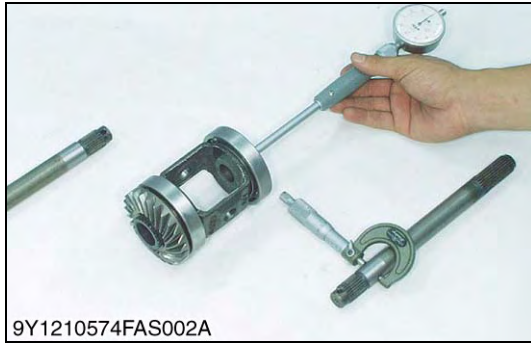

Clearance between Differential Case and Yoke Shaft

1. Measure the yoke shaft O.D. with an outside micrometer.
2. Measure the differential case bore I.D. with a cylinder gauge, and calculate the clearance.
3. If the clearance exceeds the allowable limit, replace damage parts.

Clearance between differential case and yoke shaft	Factory specification	0.020 to 0.051 mm 0.00079 to 0.0020 in.
	Allowable limit	0.2 mm 0.008 in.

Differential pinion shaft I.D.	Factory specification	20.000 to 20.018 mm 0.78741 to 0.78811 in.
Yoke shaft O.D.	Factory specification	19.967 to 19.980 mm 0.78611 to 0.78661 in.

9Y1210982FAS0019US0

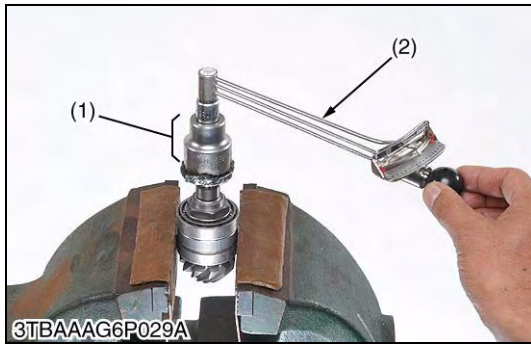

Turning Torque of Spiral Bevel Pinion Shaft

1. Cramp the spiral bevel pinion shaft assembly to the vise and tighten the staking nut.
2. Measure the turning torque of bevel pinion shaft.
3. If the turning torque is not within the factory specifications, adjust with the lock nut.

Turning torque	Factory specification	0.8 to 1.0 N·m 0.08 to 0.10 kgf·m 0.59 to 0.73 lbf·ft
----------------	-----------------------	---

■ **NOTE**

- After turning force adjustment, be sure to stake the lock nut.

(1) Adaptor

(2) Torque Wrench

9Y1210982FAS0020US0

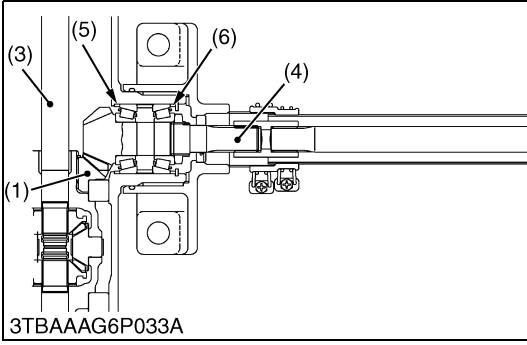
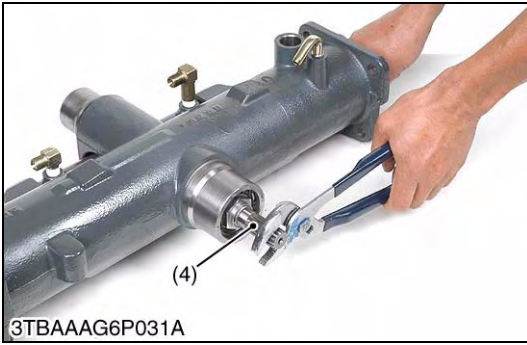
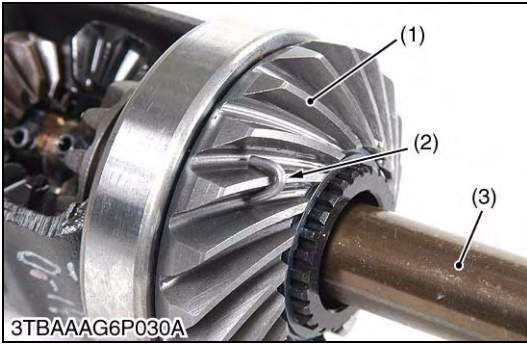

Backlash between Spiral Bevel Pinion Shaft and Spiral Bevel Gear

1. Place the solder wire (2) on the gear tooth of the spiral bevel gear (1).
2. Install the spiral bevel gear (1) and the differential yoke shaft (3) into the front axle case.
3. Install the spiral bevel pinion shaft (4) to the front axle case. Install the internal cir-clip to the front axle case.
4. Turn the spiral bevel pinion shaft (4) holding the differential yoke shaft (3) by hand lightly.
5. Remove the solder wire (2). And measure the solder wire (2).
6. If the backlash is not within the factory specifications, change the adjusting collars (5), (6). For example change the adjusting collar (6) to 0.1 mm (0.004 in.) smaller size, and change the adjusting collar (5) to 0.1 mm (0.004 in.) larger size.
7. Adjust the backlash properly by repeating the above procedures.

Backlash between spiral bevel pinion shaft and spiral bevel gear	Factory specification	0.10 to 0.30 mm 0.0040 to 0.011 in.
--	-----------------------	--

(Reference)

- Above factory specification should be measured on the tooth of spiral bevel pinion. When measuring the backlash on the spline of its shaft, factory specification will be 0.0571 to 0.1714 mm (0.00225 to 0.00675 in.).
- Thickness of adjusting collars (5), (6):
 - 3.4 mm (0.134 in.)
 - 3.6 mm (0.142 in.)
 - 3.8 mm (0.150 in.)
 - 4.0 mm (0.157 in.)
 - 4.1 mm (0.161 in.)
 - 4.2 mm (0.165 in.)
 - 4.4 mm (0.173 in.)
 - 4.6 mm (0.181 in.)

- | | |
|----------------------------------|-------------------------------|
| (1) Spiral Bevel Gear | (4) Spiral Bevel Pinion Shaft |
| (2) Solder Wire | (5) Adjusting Collar |
| (3) Differential Yoke Shaft (RH) | (6) Adjusting Collar |

9Y1210982FAS0021US0

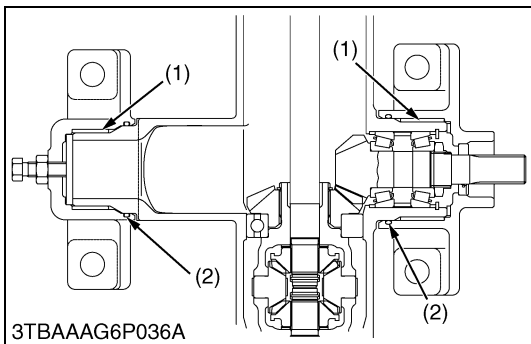
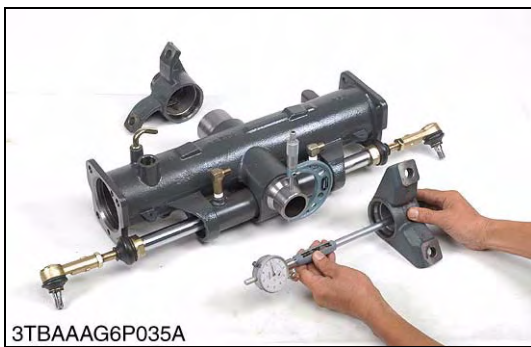

Clearance between Front Axle Case Bosses and Bracket Bushing

1. Measure the front axle case bosses O.D. with an outside micrometer.
2. Measure the bracket Bushing I.D. with a cylinder gauge, and calculate the clearance.
3. If the clearance exceeds the allowable limit, replace the bracket bushing.
4. If the clearance still exceeds the allowable limit, replace the front axle case.

Clearance between front axle case boss (front) and bracket bushing (front)	Factory specification	0.125 to 0.285 mm 0.00493 to 0.0112 in.
	Allowable limit	0.45 mm 0.018 in.

Front axle case boss (front) O.D.	Factory specification	54.94 to 54.97 mm 2.163 to 2.164 in.
-----------------------------------	-----------------------	---

Bracket bushing (front) I.D.	Factory specification	55.095 to 55.225 mm 2.1691 to 2.1742 in.
------------------------------	-----------------------	---

Clearance between front axle case boss (rear) and bracket bushing (rear)	Factory specification	0.120 to 0.300 mm 0.00473 to 0.0118 in.
	Allowable limit	0.45 mm 0.018 in.

Front axle case boss (rear) O.D.	Factory specification	65.005 to 65.035 mm 2.5593 to 2.5604in.
----------------------------------	-----------------------	--

Bracket bushing (rear) I.D.	Factory specification	65.155 to 65.305 mm 2.5652 to 2.5710 in.
-----------------------------	-----------------------	---

■ **Press-fitting Bushing**

- When replacing the bushings (1), press-fit it until bushing contact to inside of the front axle bracket holder.
- Apply grease to the O-rings (2) and take care not to damage it.

■ **NOTE**

- **After replacing the bushing, be sure to adjust the front axle rocking force. (See page 6-S4.)**

(1) Bushing

(2) O-ring

9Y1210982FAS0023US0

7 STEERING

MECHANISM

CONTENTS

1. HYDRAULIC CIRCUIT	7-M1
2. STEERING CONTROLLER.....	7-M2
3. STEERING CYLINDER	7-M3
4. HYDRAULIC PUMP.....	7-M4

1. HYDRAULIC CIRCUIT

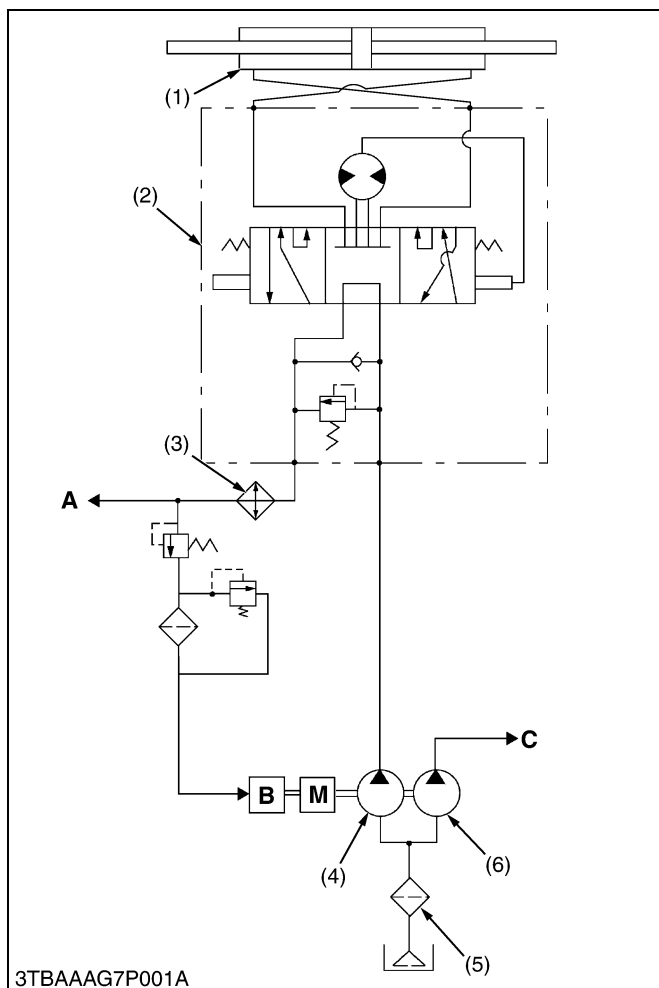

The model is provided with a full hydrostatic power steering.

In the hydrostatic power steering, the steering control is connected to the steering cylinder with only the hydraulic piping. Accordingly, it does not have mechanical transmitting parts such as steering gear, pitman arm, drag link, etc.. Therefore, it is simple in construction. This steering system consists of oil filter cartridge (5), hydraulic pump (4), steering controller (2), steering cylinder (1), etc..

By operating the power steering body, the required amount of oil is fed to the steering cylinder (1).

- | | |
|--|---|
| (1) Power Steering Cylinder | A: Independent PTO Control Valve |
| (2) Power Steering Controller | B: HST |
| (3) Oil Cooler | C: To 3-Points Hitch |
| (4) Hydraulic Pump (for Power Steering, Independent PTO and HST) | |
| (5) Oil Filter Cartridge | |
| (6) Hydraulic Pump (for 3-Points Hitch) | |

9Y1210982STM0001US0

2. STEERING CONTROLLER

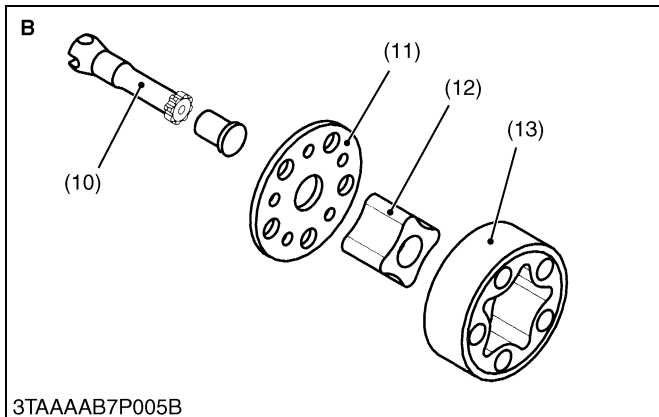
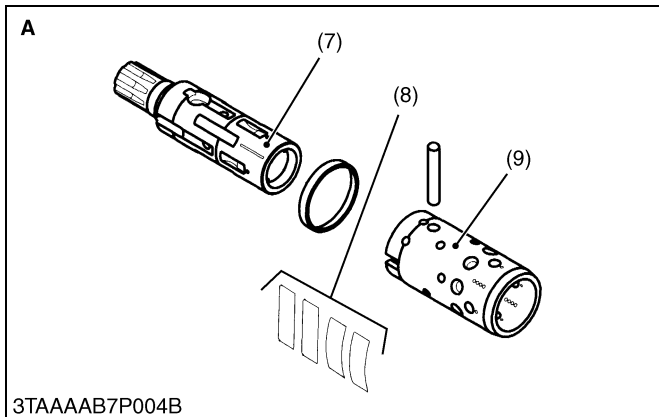
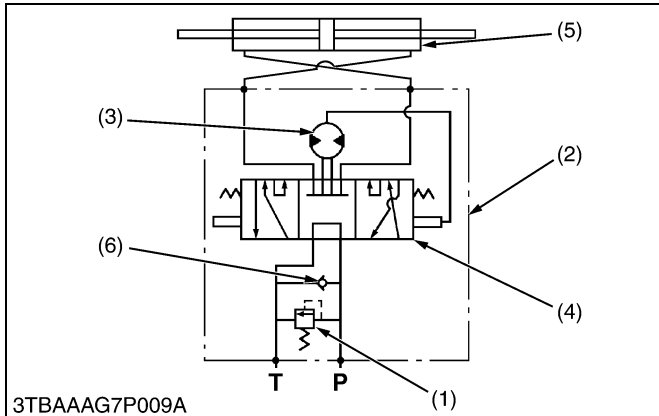
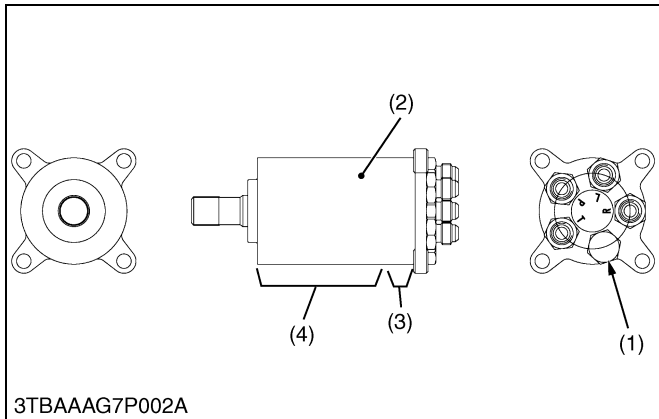

The steering controller consists of a control valve (4) and a metering device (3).

■ Control Valve

The control valve is a rotating spool type. When the steering wheel is not turned, the position of the spool (7) and sleeve (9) is kept neutral by the centering spring (8). This causes the forming of a "Neutral" oil circuit. When the steering wheel is turned either clockwise or counterclockwise, the position of the spool and sleeve changes in relation to the centering spring. This allows the forming of a "Right Turning" or "Left Turning" oil circuit. At the same time, the gear pump (Metering device) rotates with the spool and sends the oil to the cylinder corresponding to the rotation of the steering wheel.

■ Metering Device

An oil, sent from the hydraulic pump to the steering cylinder, passes through the metering device (3). Namely, when the rotor is driven, two chambers suck in oil due to volumetric change in the pump chambers formed between the rotor (12) and the stator (13), while oil is discharged from other two chambers. On the other hand, rotation of the steering wheel is directly transmitted to the rotor through the spool (7), drive shaft (10), etc. Accordingly, the metering device serves to supply the steering cylinder with oil, amount of which corresponds to the rotation of the steering wheel. The wheels are thus turned by the angle corresponding to the rotation of the steering wheel. When the engine stops or the hydraulic pump malfunctions, the metering device functions as a manual trochoid pump, which makes manual steering possible.

■ Relief Valve

The relief valve (1) is located in the steering controller. It controls the maximum pressure of the power steering system.

Its setting pressure is as follows

- 11.5 to 12.5 MPa
- 118 to 127 kgf/cm²
- 1670 to 1810 psi

- | | |
|-------------------------|--|
| (1) Relief Valve | (12) Rotor |
| (2) Steering Controller | (13) Stator |
| (3) Metering Device | |
| (4) Control Valve | A: Control Valve |
| (5) Steering Cylinder | B: Metering Device |
| (6) Check Valve | P: P Port (from Hydraulic Pump) |
| (7) Spool | T: T Port (to Independent PTO Clutch Valve and HST Circuit) |
| (8) Centering Spring | |
| (9) Sleeve | |
| (10) Drive Shaft | |
| (11) Distributor Plate | |

9Y1210982STM0002US0

3. STEERING CYLINDER

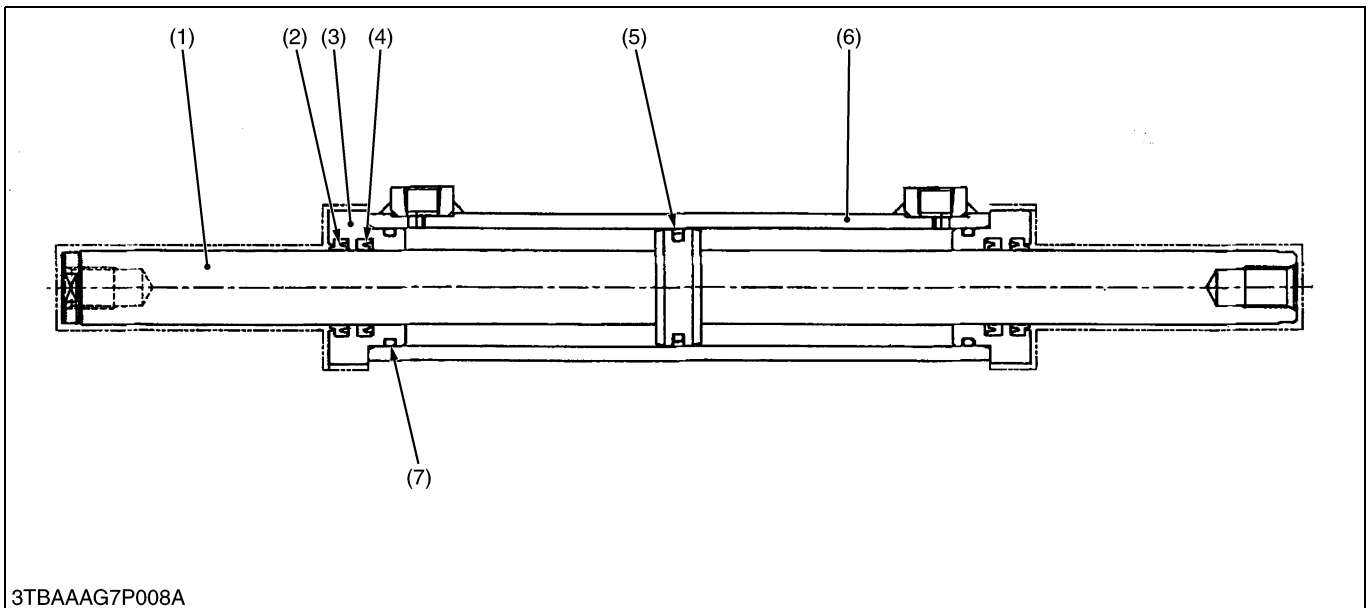

- | | | | |
|---------------|---------------|-------------------|------------|
| (1) Rod | (3) Rod Cover | (5) Piston Seal | (7) O-ring |
| (2) Dust Seal | (4) U gasket | (6) Cylinder Tube | |

The steering cylinder is single piston both rod double-acting type. This steering cylinder is installed parallel to the front axle and connected to tie-rods.

The tie-rods connected to both knuckle arm guarantees equal steering movement to both front wheels.

The steering cylinder provide force in both directions. Depending upon direction the steering wheel is turned pressure oil enters at one end of the cylinder to extend, or the other end to retract it, thereby turning front wheel of the tractor.

9Y1210982STM0003US0

4. HYDRAULIC PUMP

- See page 8-M4.

9Y1210982STM0004US0

SERVICING

CONTENTS

1. TROUBLESHOOTING.....	7-S1
2. SERVICING SPECIFICATIONS.....	7-S3
3. TIGHTENING TORQUES.....	7-S4
4. CHECKING, DISASSEMBLING AND SERVICING.....	7-S5
[1] CHECKING.....	7-S5
(1) Relief Valve.....	7-S5
(2) Hydraulic Pump for Power Steering.....	7-S5
[2] DISASSEMBLING.....	7-S5
(1) Separating Power Steering Controller (CABIN Type).....	7-S5
(2) Separating Power Steering Controller (ROPS Type).....	7-S7
(3) Power Steering Controller (ROPS Type).....	7-S7
(4) Power Steering Cylinder.....	7-S8
[3] SERVICING.....	7-S10
(1) Power Steering Cylinder.....	7-S10

1. TROUBLESHOOTING

Symptom	Probable Cause and Checking Procedure	Solution	Reference Page
Cannot Be Steered	1. Steering controller malfunctioning	Replace steering controller	7-S6
Hard Steering	1. Tire air pressure of the tires is incorrect	Check air pressure	G-56
	2. Oil leak from pipe joint	Check hose joint	7-S6
	3. Hydraulic pump malfunctioning	Solution order 1. Check hydraulic flow test	8-S8
		2. Replace hydraulic pump	8-S11
	4. Improper relief valve pressure	Solution order 1. Check system pressure	7-S5
		2. Replace steering controller	7-S6, 7-S7
5. Steering controller malfunctioning	Solution order 1. Check system pressure	7-S5	
	2. Replace steering controller	7-S6, 7-S7	
Steering Force Fluctuates	1. Air sucked in pump due to lack of oil	Check transmission oil	G-8
	2. Air sucked in pump from suction circuit	Bleed air	7-S6, 7-S7
	3. Steering controller malfunctioning	Solution order 1. Check system pressure	7-S5
2. Replace steering controller		7-S6, 7-S7	
Steering Wheel Turns Spontaneously When Released	1. Steering controller malfunctioning	Solution order 1. Check system pressure	7-S5
		2. Replace steering controller	7-S6, 7-S7

Symptom	Probable Cause and Checking Procedure	Solution	Reference Page
Low Operating Pressure	1. Oil leak from pipe	Check or replace pipe	7-S6
	2. Pipe or hose broken	Replace pipe or hose	7-S6, 7-S7
	3. Hydraulic pump malfunctioning	Solution order 1. Check hydraulic flow test	8-S8
		2. Replace hydraulic pump	8-S11
	4. Improper relief valve adjustment	Solution order 1. Check system pressure	7-S5
		2. Replace steering controller	7-S6, 7-S7
	5. Relief Valve malfunctioning	Solution order 1. Check system pressure	7-S5
2. Replace steering controller		7-S6, 7-S7	
Front Wheels Wander to Right and Left	1. Tire air pressure of the tires is incorrect	Check air pressure	G-56
	2. Improper toe-in adjustment	Adjust toe-in	6-S4
	3. Insufficient bleeding	Bleed air	7-S6, 7-S7
	4. Air sucked in pump due to lack of oil	Check transmission oil	G-8
	5. Air sucked in pump from suction circuit	Bleed air	7-S6, 7-S7
	6. Steering controller malfunctioning	Solution order 1. Check system pressure	7-S5
2. Replace steering controller		7-S6, 7-S7	
Wheels Are Turned to a Direction Opposite to Steering Direction	1. Cylinder piping connected in reverse	Repair steering cylinder hose	6-S5
Steering Wheel Turns Idle in Manual Steering	1. Insufficient bleeding	Bleed air	7-S6, 7-S7
	2. Air sucked in due to lack of oil	Check transmission oil	G-8
Noise	1. Air sucked in pump due to lack of oil	Check transmission oil	G-8
	2. Air sucked in pump from suction circuit	Bleed air	7-S6, 7-S7
	3. Hose deformed	Replace hose	7-S6, 7-S7
Oil Temperature Increases Rapidly	1. Steering controller (relief valve) malfunctioning	Solution order 1. Check system pressure	7-S5
		2. Replace steering controller	7-S6, 7-S7

9Y1210982STS0001US0

2. SERVICING SPECIFICATIONS

POWER STEERING BODY

Item		Factory Specification	Allowable Limit
Relief Valve	Setting Pressure	11.5 to 12.5 MPa 118 to 127 kgf/cm ² 1670 to 1810 psi	–

POWER STEERING CYLINDER

Item		Factory Specification	Allowable Limit
Steering Cylinder	I.D.	40.000 to 40.062 mm 1.57480 to 1.57724 in.	40.100 mm 1.57874 in.
Piston Rod to Guide	Clearance	0.020 to 0.070 mm 0.00079 to 0.00276 in.	0.200 mm 0.00787 in.

9Y1210982STS0002US0

3. TIGHTENING TORQUES

Tightening torques of screws, bolts and nuts on the table below are especially specified.
(For general use screws, bolts and nuts: See page G-10.)

Item	N·m	kgf·m	lbf·ft
Power steering hose for power steering cylinder	24 to 28	2.5 to 2.9	18 to 20
Power steering controller for pipes and hoses	24 to 28	2.5 to 2.9	18 to 20
Universal joint mounting bolt	24 to 28	2.5 to 2.9	18 to 20
Tie-rod slotted nut	18 to 35	1.9 to 3.5	14 to 25
Tie-rod joint	74 to 84	7.5 to 8.5	55 to 61

9Y1210982STS0003US0

4. CHECKING, DISASSEMBLING AND SERVICING

[1] CHECKING

(1) Relief Valve

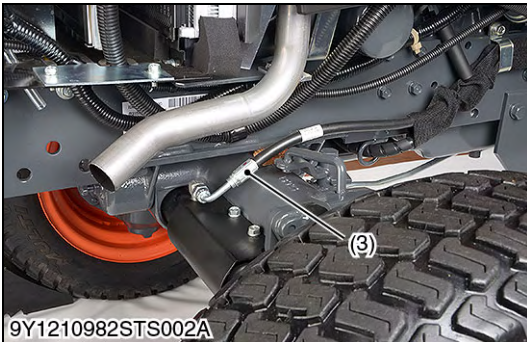
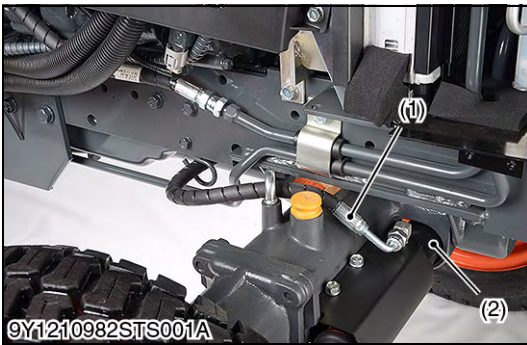

Relief Valve Operating Pressure

1. Disconnect the power steering hose L.H. (or R.H.) from steering the power steering cylinder, and set a pressure gauge and cable.

(Reference)

- Hose and adaptor size: 9/16-18UNF, 37 ° flare.
2. Start the engine and set at maximum speed.
 3. Fully turn the steering wheel to the left (or right) to check the feeling which the steering wheel lightly locks. Read the relief valve operating pressure when the steering wheel to the above-mentioned lock position by operation force at approximately 9.8 N (1 kgf, 2.2 lbf) of outer.

■ **NOTE**

- **After set a pressure gauge, be sure to bleed air.**
- **Note that the pressure value changes by the pump action of the power steering controller when the steering operation is continued after the steering wheel is lightly locked and accurate relief valve pressure cannot be measured.**

(Bleeding air in power steering circuit)

- Start the engine.
- Turn the steering wheel slowly in both directions all the way alternately several times, and stop the engine.

Relief valve operating pressure	Factory specification	11.5 to 12.5 MPa 118 to 127 kgf/cm ² 1670 to 1810 psi
Tightening torque	Power steering hose for power steering cylinder	24 to 28 N·m 2.5 to 2.9 kgf·m 18 to 20 lbf·ft

- (1) Power Steering Hose (R.H.)
(2) Power Steering Cylinder

- (3) Power Steering Hose (L.H.)

9Y1210982STS0004US0

(2) Hydraulic Pump for Power Steering

- See page 8-M4.

9Y1210982STS0013US0

[2] DISASSEMBLING

(1) Separating Power Steering Controller (CABIN Type)

Separating Cabin from Tractor Body

- See page 10-S32.

9Y1210982STS0014US0

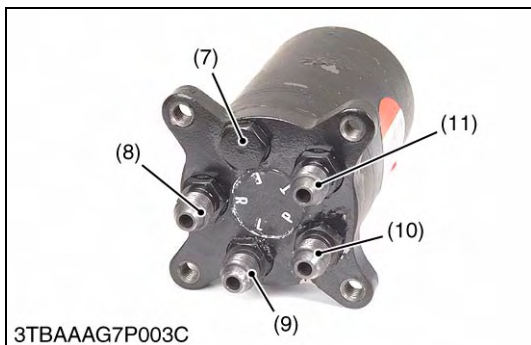
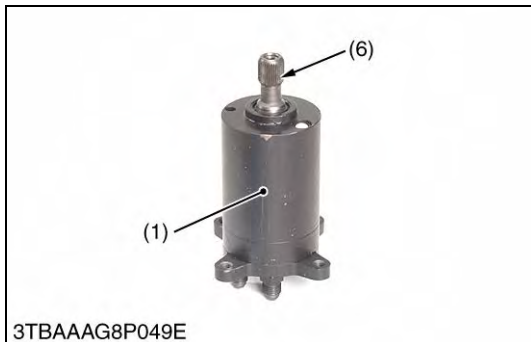
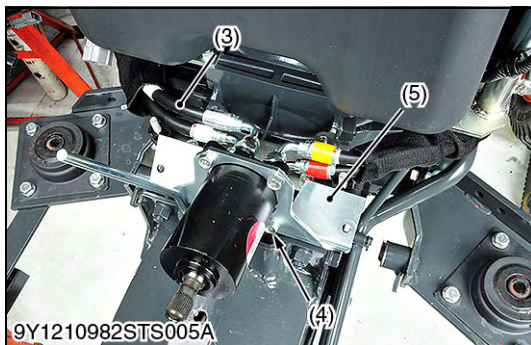
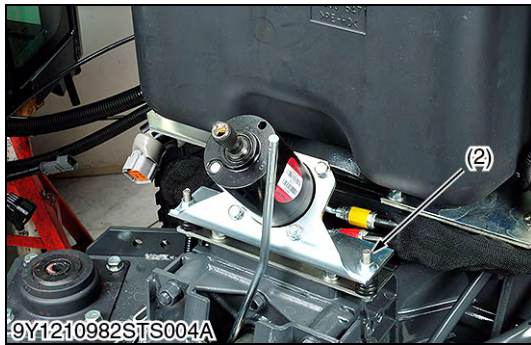
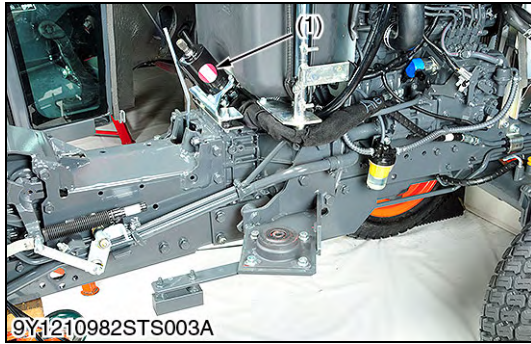

Power Steering Controller

1. Remove the nuts (2).
2. Disconnect the power steering hoses (3) from the power steering controller (1).
3. Remove the power steering controller mounting bolts (4) from the stay.

(When reassembling)

- Connect the power steering hoses (3) to the power steering controller (1) securely.
- If oil leaking from the power steering controller (1) is found, replace the power steering controller (1). O-ring in the power steering controller (1) is not supplied as a spare part.
- Align the power steering controller shaft (6) to the universal joint securely.

Tightening torque	Power steering controller for hoses	24 to 28 N·m 2.5 to 2.8 kgf·m 17 to 20 lbf·ft
-------------------	-------------------------------------	---

- | | |
|----------------------------------|----------------------------------|
| (1) Power Steering Controller | (7) Relief Valve |
| (2) Nut | (8) Adaptor (to Right Cylinder) |
| (3) Power Steering Hose | (9) Adaptor (to Left Cylinder) |
| (4) Power Steering Mounting Bolt | (10) Adaptor (to Hydraulic Pump) |
| (5) Stay | (11) Adaptor (to Oil Cooler) |
| (6) Power Steering Shaft | |

9Y1210982STS0015US0

(2) Separating Power Steering Controller (ROPS Type)

Steering Wheel, Meter Panel Bonnet and Fuel Tank

- See page 3-S23.

9Y1210982STS0005US0

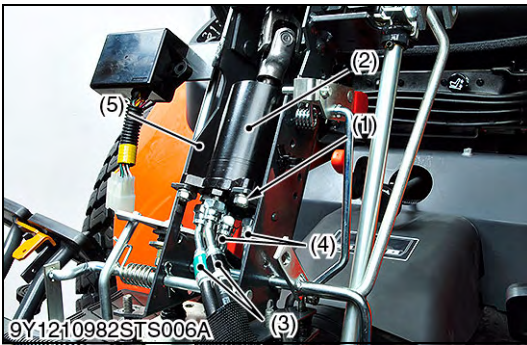

Steering Post Assembly

1. Remove the steering post mounting bolts.
2. Disconnect the power steering hoses (4) from the power steering controller (2).
3. Disconnect the power steering hoses (3) from the power steering controller (2).
4. Remove the steering post assembly (5) from the main frame.

(When reassembling)

- Connect the power steering hoses (3) and the power steering hoses (4) to the power steering controller (2) securely.

Tightening torque	Power steering controller for pipes and hoses	24 to 28 N·m 2.5 to 2.9 kgf·m 18 to 20 lbf·ft
-------------------	---	---

- | | |
|-------------------------------|----------------------------|
| (1) Bolt | (4) Power Steering Hose |
| (2) Power Steering Controller | (5) Steering Post Assembly |
| (3) Power Steering Hose | |

9Y1210982STS0006US0

(3) Power Steering Controller (ROPS Type)

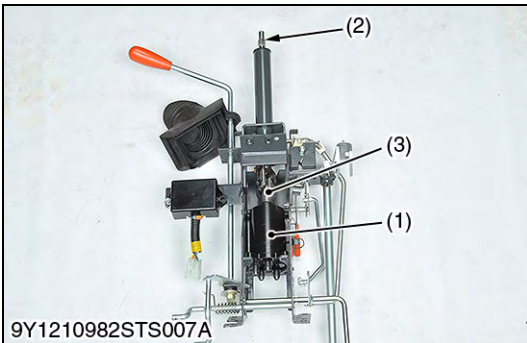

Power Steering Controller

1. Remove the bolt from the universal joint (4).
2. Remove the power steering controller (1) from the steering post.

(When reassembling)

- If oil leaking from the power steering controller (1) is found, replace the power steering controller (1). O-ring in the power steering controller (1) is not supplied as a spare part.
- Align the power steering controller shaft (5) to the universal joint (4) securely.

Tightening torque	Universal joint mounting bolt	24 to 28 N·m 2.5 to 2.8 kgf·m 18 to 20 lbf·ft
-------------------	-------------------------------	---

- | | |
|-------------------------------|---------------------------------|
| (1) Power Steering Controller | (6) Adaptor (to Right Cylinder) |
| (2) Steering Shaft | (7) Adaptor (to Left Cylinder) |
| (3) Universal Joint | (8) Adaptor (to Hydraulic Pump) |
| (4) Power Steering Shaft | (9) Adaptor (to Oil Cooler) |
| (5) Relief Valve | |

9Y1210982STS0007US0

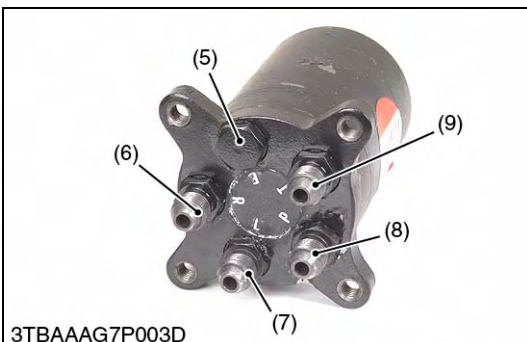
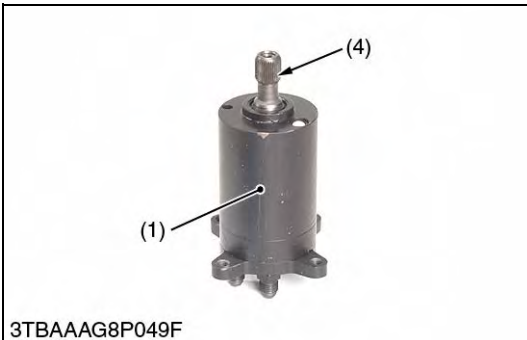

(4) Power Steering Cylinder

Front Wheels

- See page 6-S5.

9Y1210982STS0008US0

Tie-rod Joint

1. Remove the slotted nut (4) and remove the tie-rod end (3).
2. Remove the front axle brackets (1), (2).

(When reassembling)

- Apply grease to the thrust collar of front axle bracket.
- Apply grease to the O-ring and be careful not to damage it.
- After tightening the slotted nut, install cotter pin as shown in the figure.

(Bleeding air in power steering circuit)

- Start the engine.
- Turn the steering wheel slowly in both directions all the way alternately several times, and stop the engine.

Tightening torque	Tie-rod slotted nut	18 to 35 N·m 1.9 to 3.5 kgf·m 14 to 25 lbf·ft
	Tie-rod joint	74 to 84 N·m 7.6 to 8.5 kgf·m 55 to 61 lbf·ft

- | | |
|--------------------------------|-----------------|
| (1) Front Axle Bracket (Front) | (4) Slotted Nut |
| (2) Front Axle Bracket (Rear) | (5) Cotter Pin |
| (3) Tie-rod End | |

9Y1210982STS0009US0

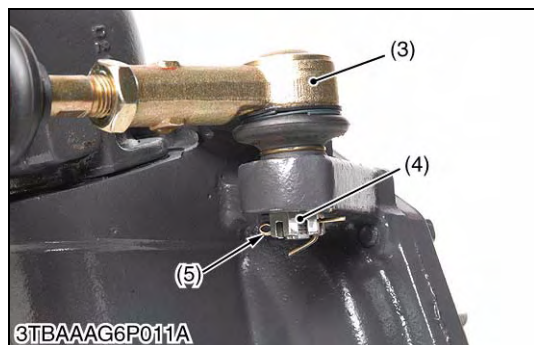
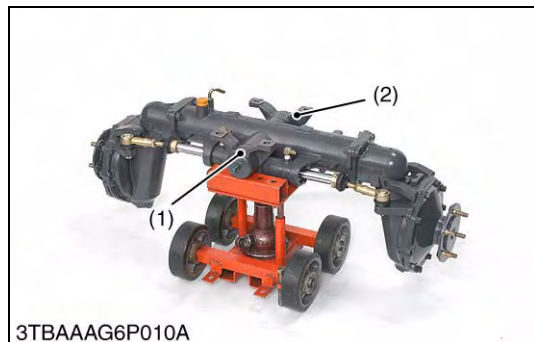

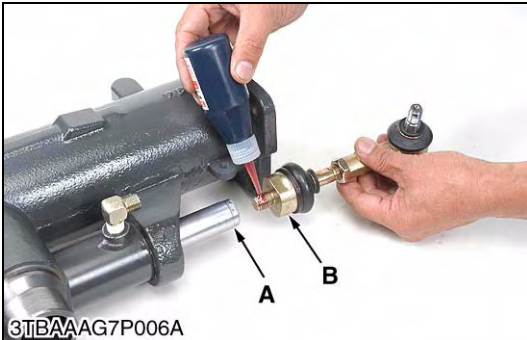
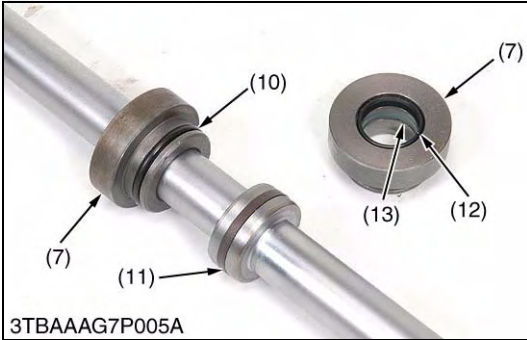
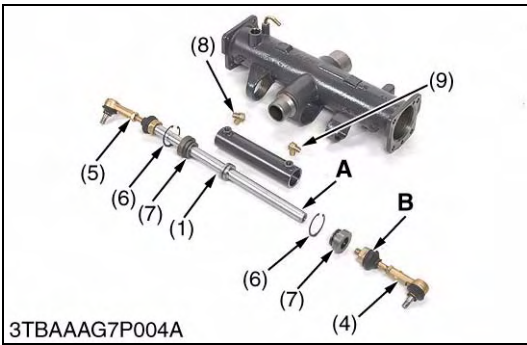
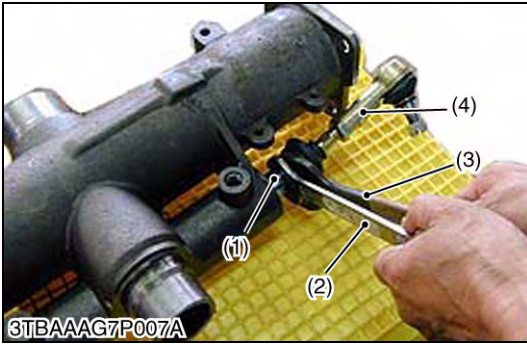

Power Steering Cylinder

⚠ CAUTION

- Since power steering cylinder is full of high-pressured steering oil, high-pressured oil is injected out from hose adopters by pushing piston rods.
- This injected oil can penetrate the skin or eyes causing serious injury.
- Use appropriate protective wear to prevent serious injury.
- Use waste to cover the adopters.
- Before disassembling drain steering oil from power steering cylinder.

1. Remove the tie-rod end (4) from the rod (1) using spanners (2), (3).
2. Remove the adaptors (8), (9).
3. Remove the rod cover (7).
4. Tap out the rod (1) to the right front wheel side.

(When reassembling)

- Apply the liquid lock (Three Bond 1375N or equivalent) to the tie-rod ends (4), (5).

Tightening torque	Tie-rod joint	74 to 84 N·m 7.5 to 8.6 kgf·m 55 to 61 lbf·ft
-------------------	---------------	---

- | | |
|------------------------|---|
| (1) Rod | (10) O-ring |
| (2) Thin Spanner | (11) Gasket |
| (3) Standard Spanner | (12) Dust Seal |
| (4) Tie-rod End (L.H.) | (13) U Gasket |
| (5) Tie-rod End (R.H.) | |
| (6) Internal Cir-clip | A: Position for thin thickness spanner |
| (7) Rod Cover | B: Position for standard thickness spanner |
| (8) Adaptor (R.H.) | |
| (9) Adaptor (L.H.) | |

9Y1210982STS0010US0

[3] SERVICING

(1) Power Steering Cylinder

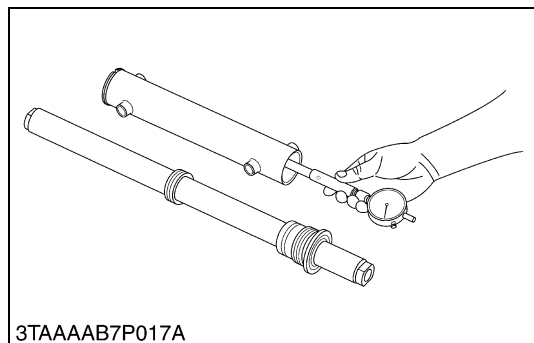

Steering Cylinder I.D.

1. Measure the steering cylinder I.D. with a cylinder gauge.
2. If the cylinder I.D. exceed the allowable limit, replace the cylinder barrel.

Steering cylinder I.D.	Factory specification	40.000 to 40.062 mm 1.57480 to 1.57724 in.
	Allowable limit	40.100 mm 1.57874 in.

9Y1210982STS0011US0

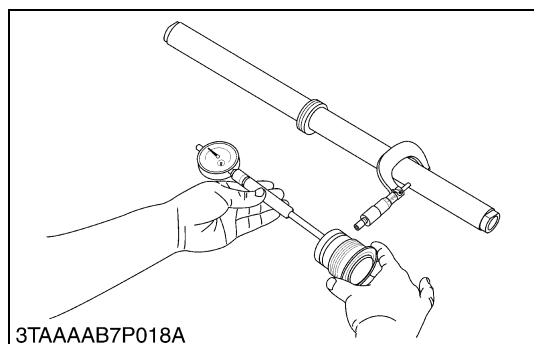

Clearance between Rod and Guide

1. Measure the rod guide I.D. with a cylinder gauge.
2. Measure the rod O.D. with an outside micrometer, and calculate the clearance.
3. If the clearance exceeds the allowable limit, replace as a unit.

Clearance between rod and guide	Factory specification	0.020 to 0.070 mm 0.00079 to 0.00276 in.
	Allowable limit	0.200 mm 0.00787 in.

9Y1210982STS0012US0

8 HYDRAULIC SYSTEM

MECHANISM

CONTENTS

1. HYDRAULIC CIRCUIT	8-M1
[1] MANUAL TRANSMISSION MODEL (WITHOUT BI-SPEED TURN).....	8-M1
[2] MANUAL TRANSMISSION MODEL (WITH BI-SPEED TURN).....	8-M2
[3] HST MODEL.....	8-M3
2. HYDRAULIC PUMP.....	8-M4
3. THREE POINTS HYDRAULIC SYSTEM.....	8-M5
[1] HYDRAULIC CIRCUIT	8-M5
(1) Manual Transmission Model (Without Front Loader Valve)	8-M5
(2) HST Model (With Front Loader Control Valve).....	8-M5
[2] RELIEF VALVE	8-M6
(1) Manual Transmission Model (Without Front Loader Valve)	8-M6
(2) HST Model (With Front Loader Control Valve).....	8-M7
[3] POSITION CONTROL VALVE	8-M8
(1) Structure	8-M8
(2) Operation.....	8-M9
[4] FEEDBACK LINKAGE FOR POSITION CONTROL	8-M11
4. FRONT LOADER CONTROL VALVE (IF EQUIPPED)	8-M12
[1] STRUCTURE	8-M12
[2] OPERATION	8-M13
5. REMOTE CONTROL VALVE (IF EQUIPPED)	8-M20
6. HYDRAULIC OUTLET.....	8-M21
[1] MANUAL TRANSMISSION MODEL	8-M21
(1) Front Hydraulic Outlet.....	8-M21
(2) Rear Hydraulic Outlet	8-M22
[2] HST MODEL.....	8-M23
(1) Rear Hydraulic Outlet	8-M23

1. HYDRAULIC CIRCUIT

[1] MANUAL TRANSMISSION MODEL (WITHOUT BI-SPEED TURN)

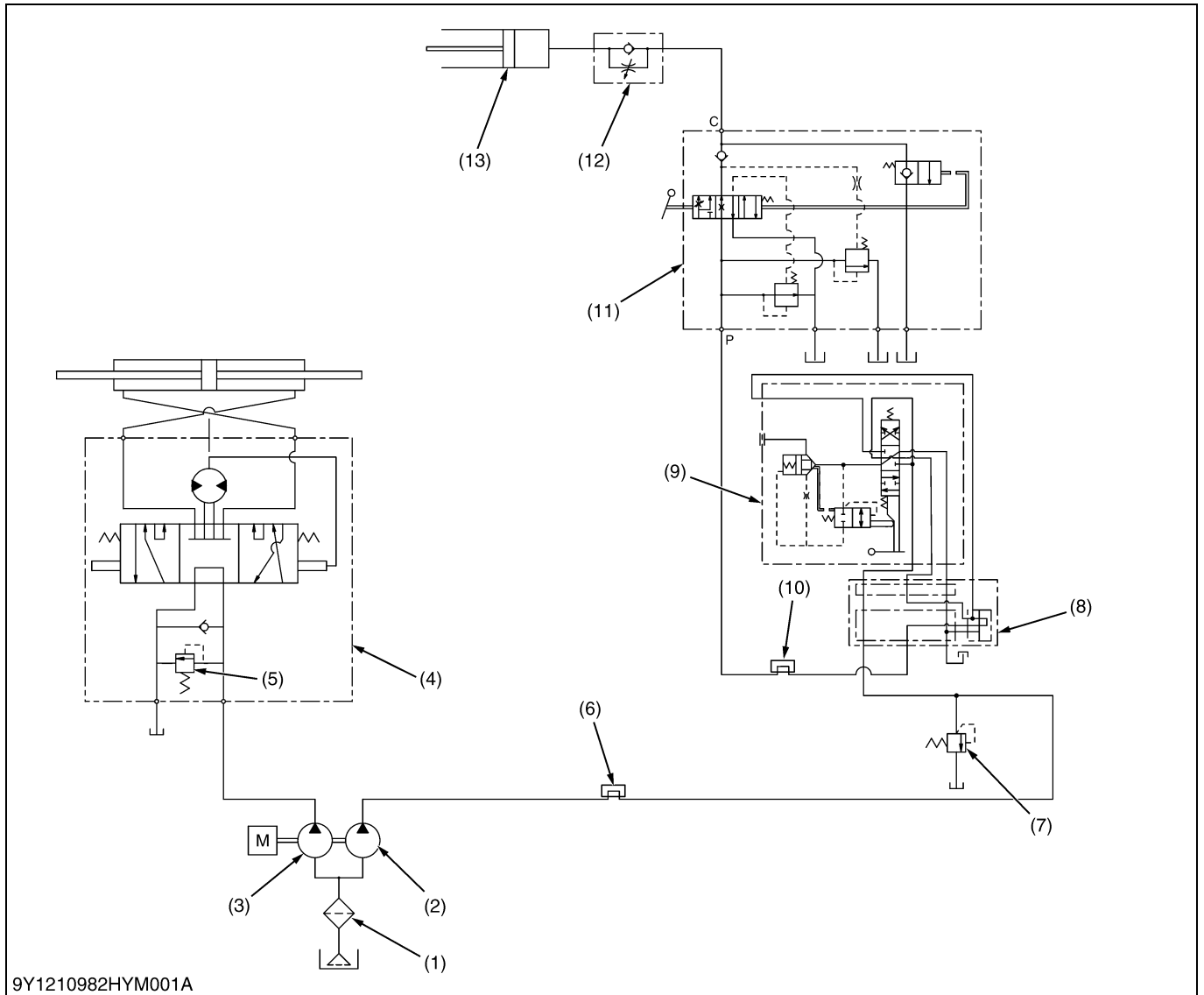

- | | | | |
|---|--|---|-------------------------------------|
| (1) Oil Filter | (4) Power Steering Controller | (7) Relief Valve (3-point Hitch System) | (11) Position Control Valve |
| (2) Hydraulic Pump (For 3-point Hitch) | (5) Relief Valve (Power Steering Controller) | (8) Hydraulic Outlet | (12) Lowering Speed Adjusting Valve |
| (3) Hydraulic Pump (For Power Steering) | (6) Front Hydraulic Outlet | (9) Remote Control Valve | (13) Hydraulic Cylinder |
| | | (10) Rear Hydraulic Outlet | |

Operating Pressure

(2)	Hydraulic Pump (For 3-point Hitch) Above 18.7 L/min. (4.94 U.S. gals/min., 4.11 Imp. gals/min.)	(5)	Relief Valve (For Power Steering Controller) 11.5 to 12.5 MPa (118 to 127 kgf/cm ² , 1670 to 1810 psi)
(3)	Hydraulic Pump (For Power Steering) Above 14.1 L/min. (3.72 U.S. gals/min., 3.10 Imp. gals/min.)	(7)	Relief Valve (For 3-point Hitch System) 15.5 to 16.5 MPa (158 to 168 kgf/cm ² , 2248 to 2393 psi)

9Y1210982HYM0001US0

[2] MANUAL TRANSMISSION MODEL (WITH BI-SPEED TURN)

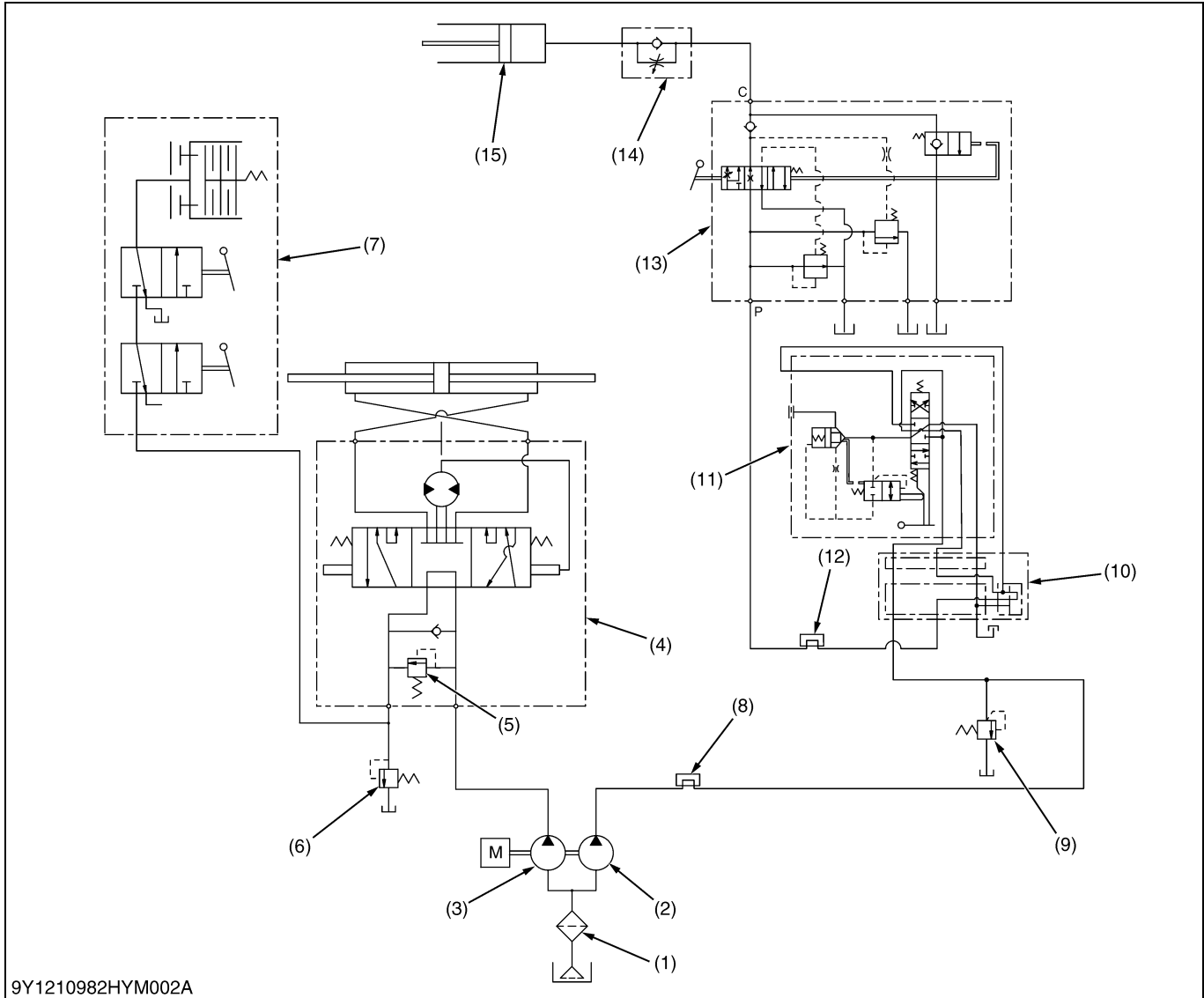

9Y1210982HYM002A

- | | | | |
|---|--|---|-------------------------------------|
| (1) Oil Filter | (5) Relief Valve (Power Steering Controller) | (8) Front Hydraulic Outlet | (12) Rear Hydraulic Outlet |
| (2) Hydraulic Pump (For 3-point Hitch) | (6) Regulating Valve (Bi-speed Turn) | (9) Relief Valve (3-point Hitch System) | (13) Position Control Valve |
| (3) Hydraulic Pump (For Power Steering and Bi-speed Turn) | (7) Bi-speed Turn Valve and Clutch | (10) Hydraulic Outlet | (14) Lowering Speed Adjusting Valve |
| (4) Power Steering | | (11) Remote Control Valve | (15) Hydraulic Cylinder |

Operating Pressure

(2)	Hydraulic Pump (For 3-point Hitch) Above 18.7 L/min. (4.94 U.S. gals/min., 4.11 Imp. gals/min.)	(6)	Regulating Valve (For Bi-speed Turn) 0.4 to 0.6 MPa (4.1 to 6.1 kgf/cm ² , 58 to 87 psi)
(3)	Hydraulic Pump (For Power Steering) Above 14.1 L/min. (3.72 U.S. gals/min., 3.10 Imp. gals/min.)	(9)	Relief Valve (For 3-point Hitch System) 15.5 to 16.5 MPa (158 to 168 kgf/cm ² , 2248 to 2393 psi)
(5)	Relief Valve (For Power Steering Controller) 11.5 to 12.5 MPa (118 to 127 kgf/cm ² , 1670 to 1810 psi)		

9Y1210982HYM002US0

[3] HST MODEL

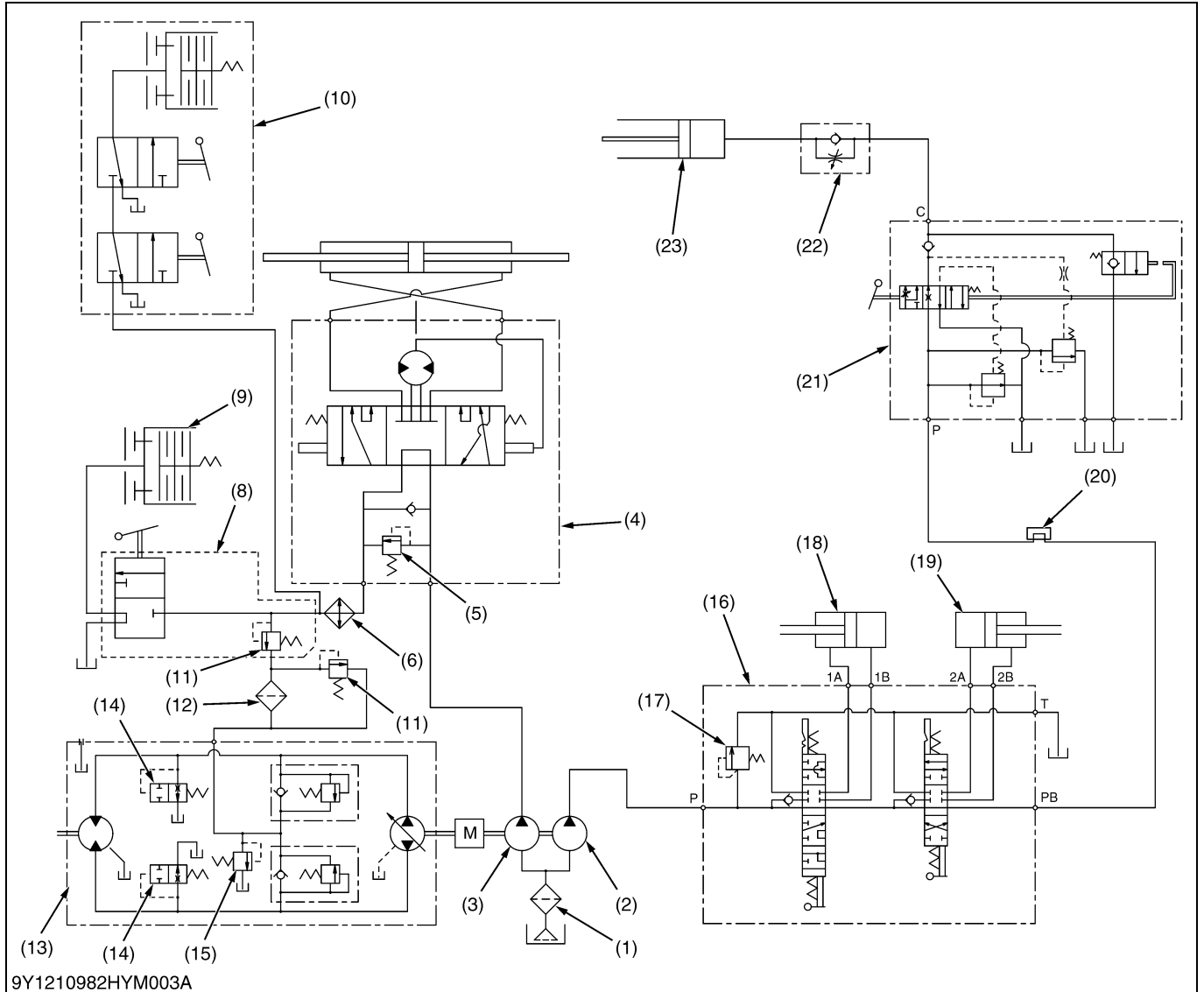

- (1) Oil Filter
- (2) Hydraulic Pump (For 3-point Hitch)
- (3) Hydraulic Pump (For Power Steering and Bi-speed Turn)
- (4) Power Steering
- (5) Relief Valve (Power Steering Controller)
- (6) Oil Cooler
- (7) Regulating Valve (Bi-speed Turn and Independent PTO Clutch)
- (8) Control Valve for Independent PTO
- (9) Independent PTO Clutch
- (10) Bi-speed Turn Valve and Clutch
- (11) Relief Valve for Oil Filter
- (12) Oil Filter
- (13) HST
- (14) Check and High Pressure Relief Valve
- (15) Charge Relief Valve
- (16) Front Loader Control Valve
- (17) Relief Valve (For 3-point Hitch System and Front Loader System)
- (18) Boom Cylinder
- (19) Bucket Cylinder
- (20) Rear Hydraulic Outlet
- (21) Position Control Valve
- (22) Lowering Speed Adjusting Valve
- (23) Hydraulic Cylinder

Operating Pressure

(2)	Hydraulic Pump (For 3-point Hitch) Above 18.7 L/min. (4.94 U.S. gals/min., 4.11 Imp. gals/min.)	(14)	Check and High Pressure Relief Valve (For HST) 33 to 35 MPa (340 to 350 kgf/cm ² , 4800 to 5000 psi)
(3)	Hydraulic Pump (For Power Steering) Above 14.1 L/min. (3.72 U.S. gals/min., 3.10 Imp. gals/min.)	(15)	Charge Relief Valve (For HST) 0.4 to 0.6 MPa (4.1 to 6.1 kgf/cm ² , 17.4 to 20.2 psi)
(5)	Relief Valve (For Power Steering Controller) 11.5 to 12.5 MPa (118 to 127 kgf/cm ² , 1670 to 1810 psi)	(17)	Relief Valve (3-point Hitch System and Front Loader System) 16.5 to 16.9 MPa (169 to 172 kgf/cm ² , 2400 to 2450 psi)
(7)	Regulating Valve (For Bi-speed Turn and Independent PTO) 1.1 to 1.5 MPa (11.2 to 15.3 kgf/cm ² , 160 to 218 psi)		

9Y1210982HYM003US0

2. HYDRAULIC PUMP

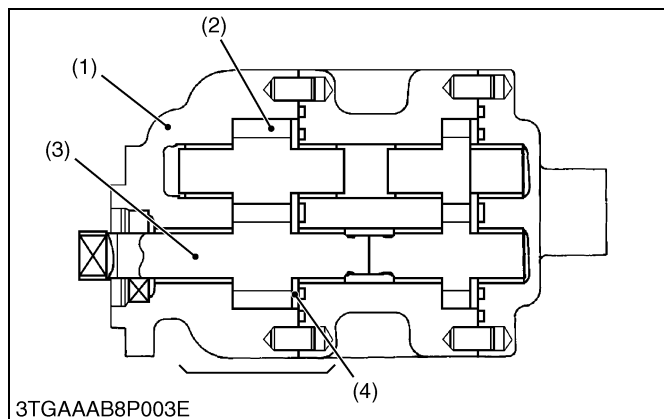
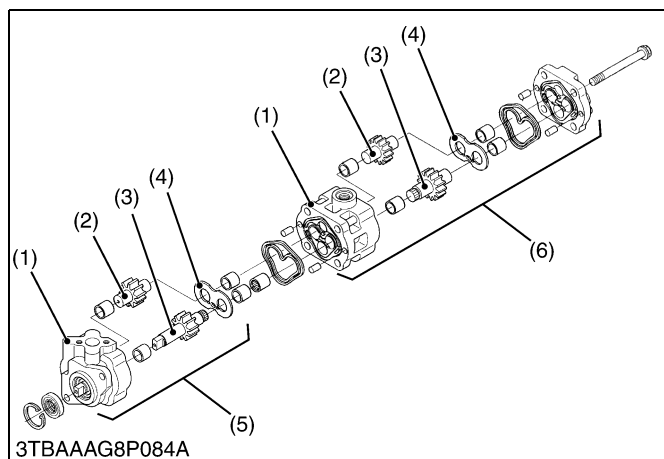

The hydraulic pump consists of the casing (1), side plate (4), and two spur gears (drive gear (3) and driven gear (2)) that are in mesh.

Hydraulic pump is driven by the fuel camshaft.

Maximum displacement is as follows.

Hydraulic Pump (for 3-points Hitch)

Displacement	Engine speed	Condition
18.7 L/min. 4.94 U.S.gals/min. 4.11 Imp.gals/min.	At 2500 min ⁻¹ (rpm)	at no load

Hydraulic Pump (for Power Steering)

Displacement	Engine speed	Condition
14.1 L/min. 3.72 U.S.gals/min. 3.10 Imp.gals/min.	At 2500 min ⁻¹ (rpm)	at no load

- (1) Casing
- (2) Driven Gear
- (3) Drive Gear
- (4) Side Plate
- (5) Hydraulic Pump (for 3-Points Hitch)
- (6) Hydraulic Pump (for Power Steering)

9Y1210982HYM0004US0

3. THREE POINTS HYDRAULIC SYSTEM

[1] HYDRAULIC CIRCUIT

(1) Manual Transmission Model (Without Front Loader Valve)

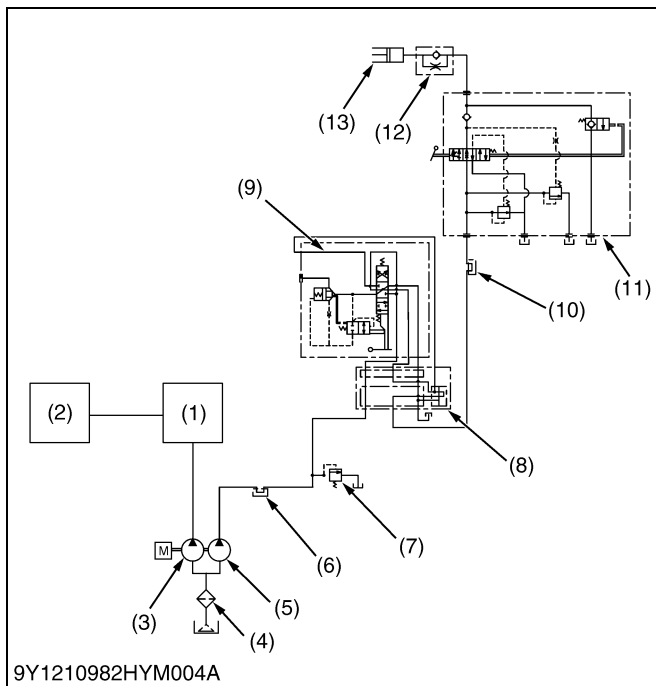

Two hydraulic pumps (4), (6) are installed in this series tractors.

Hydraulic oil is forced from hydraulic pump (5) to the hydraulic outlet (6), relief valve (7), rear outlet (8) and position control valve (11).

Three point hydraulic oil pressure is controlled by the relief valve (7).

- | | |
|---|-------------------------------------|
| (1) Power Steering Controller | (6) Hydraulic Outlet |
| (2) Bi-speed Turn Valve and Clutch (If Equipped) | (7) Relief Valve |
| (3) Hydraulic Pump (for Power Steering and Bi-speed Turn) | (8) Rear Outlet |
| (4) Oil Filter Cartridge | (9) Remote Control Valve |
| (5) Hydraulic Pump (for 3-Points Hitch) | (10) Hydraulic Outlet |
| | (11) Position Control Valve |
| | (12) Lowering Speed Adjusting Valve |
| | (13) Hydraulic Cylinder |

9Y1210982HYM0005US0

(2) HST Model (With Front Loader Control Valve)

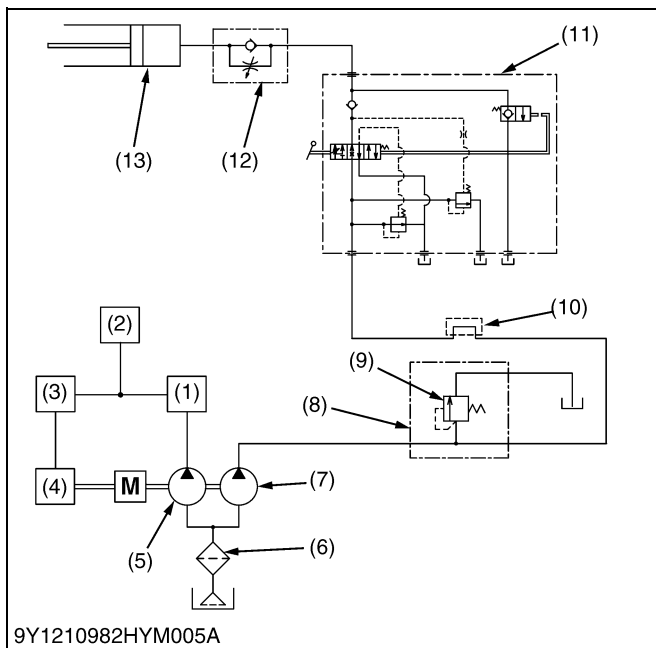

Two hydraulic pumps (5), (7) are installed in this series of machines.

Hydraulic oil is forced from hydraulic pump (7) to the loader control valve (8), relief valve (9), hydraulic outlet (10) and position control valve (11).

Three point hydraulic oil pressure is controlled by the relief valve (9).

- | | |
|---|---|
| (1) Power Steering Controller | (7) Hydraulic Pump (for 3-Points Hitch) |
| (2) Bi-speed Turn Valve and Clutch | (8) Front Loader Control Valve |
| (3) Independent PTO | (9) Relief Valve |
| (4) HST | (10) Hydraulic Outlet |
| (5) Hydraulic Pump (for Power Steering, Bi-speed Turn, Independent PTO and HST) | (11) Position Control Valve |
| (6) Oil Filter Cartridge | (12) Lowering Speed Adjusting Valve |
| | (13) Hydraulic Cylinder |

9Y1210982HYM0006US0

[2] RELIEF VALVE

(1) Manual Transmission Model (Without Front Loader Valve)

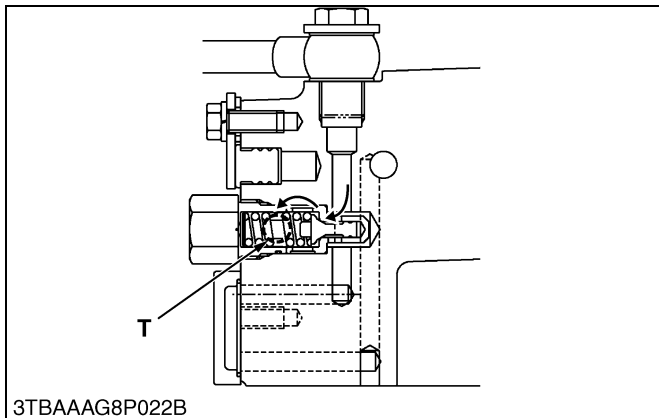
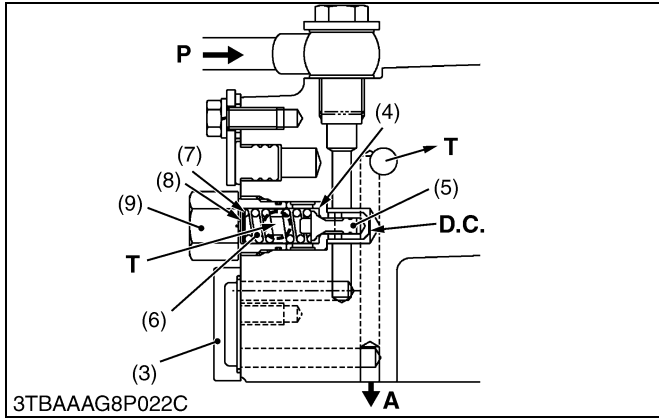
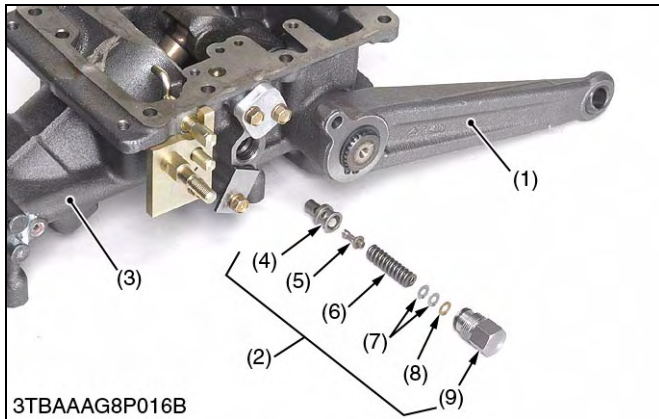
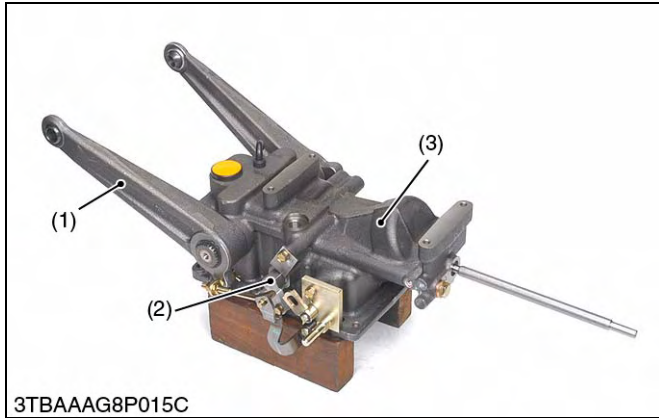

Relief valve is located at the hydraulic cylinder right hand side.

The implement control system circuit has a relief valve to restrict the maximum pressure in the circuit.

The relief valve is a guide piston type with damping effect.

Among direct acting relief valves, this type is suited to higher pressure and has larger capacity. Furthermore, this type is free from unstable operation, such as chattering, which occurs often in direct acting relief valves.

As shown in the figure, the guide is attached to the poppet (5) and a valve chamber **D.C.** (called the damping chamber) is formed at the bottom of the poppet (5). The inlet of the valve leads to the chamber via a clearance between the sliding portion of the poppet (5) and the valve seat (4), minimizing valve vibration with the damping effect of the chamber.

As the oil pressure in the circuit increases, so does the pressure in the damping chamber **D.C.**. When the pressure rises above the valve setting and overcomes the spring force, the valve opens. Oil then flows out to the transmission case through **T** port, preventing any further rise in pressure. The valve closes again when enough oil is released to drop pressure below the valve setting pressure.

(Reference)

- Relief valve setting pressure
15.5 to 16.5 MPa
158 to 168 kgf/cm²
2248 to 2393 psi

Condition

- Engine speed
Approx. 2500 min⁻¹ (rpm)
- Oil temperature
50 °C (122 °F)

- (1) Lift Arm
- (2) Relief Valve
- (3) Lift Cylinder
- (4) Valve Seat
- (5) Poppet
- (6) Spring
- (7) Shim
- (8) Washer
- (9) Plug

- A:** To Position Control Valve
- P:** Pump Port
(from Hydraulic Pump)
- T:** Tank Port
(to Transmission case)
- D.C.:** Damping Chamber

9Y1210982HYM0007US0

(2) HST Model (With Front Loader Control Valve)

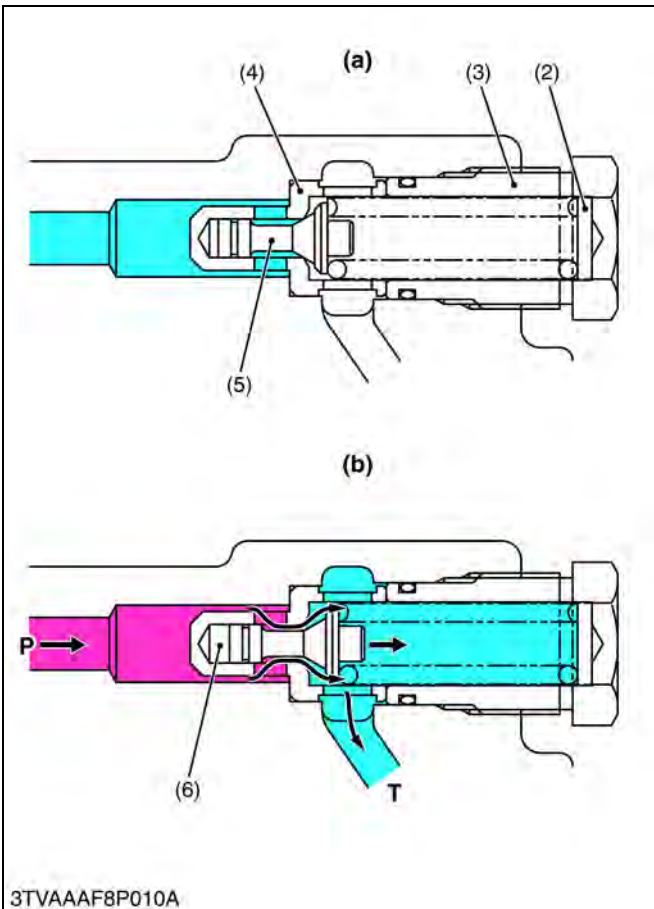
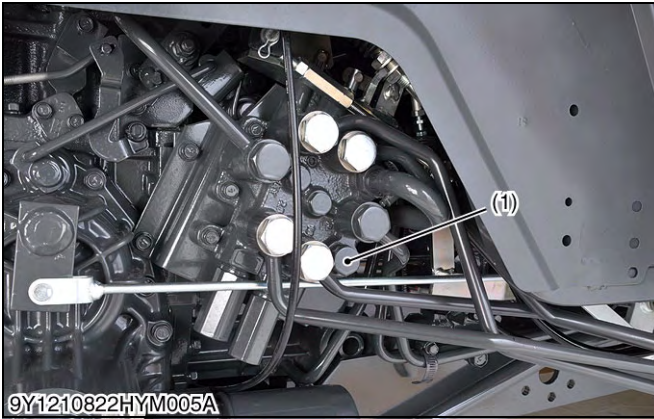

The hydraulic raising and lowering circuit is fitted with a relief valve to control the maximum pressure.

This is a guide piston relief valve with damper, a direct acting relief valve suitable for relatively high pressure and capacity, and constructed so as to prevent chattering and other unstableness associated with direct acting relief valves. As shown in the diagram, poppet (5) has a guide, and there is a valve chamber called a damping chamber (6) in the base of this guide piston. The valve inlet is connected to this chamber through the clearance between the guide surface and the seat so that the chamber provides a damping effect, controlling valve vibration.

When the pressure in the circuit rises, the pressure in the damping chamber also rises, and when it exceeds the relief pressure setting the spring is compressed, making a clearance between the poppet and the seat. The hydraulic oil can escape to the transmission case through this clearance, controlling the pressure rise.

(Reference)

- Relief valve setting pressure
16.5 to 16.9 MPa
169 to 172 kgf/cm²
2400 to 2450 psi

Condition

- Engine speed
Approx. 2500 min⁻¹ (rpm)
- Oil temperature
50 °C (122 °F)

- (1) Relief Valve
- (2) Shim
- (3) Plug
- (4) Seat
- (5) Poppet
- (6) Damping Chamber

- (a) Normal State
- (b) Active State
- T: T Port
(To Transmission Case)
- P: P Port (From Pump)

9Y1210982HYM0008US0

[3] POSITION CONTROL VALVE

(1) Structure

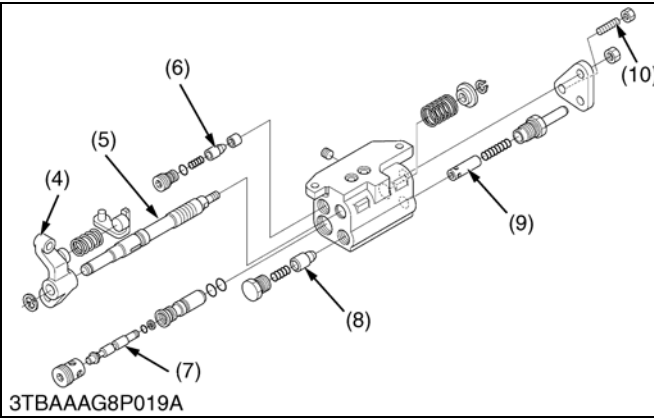
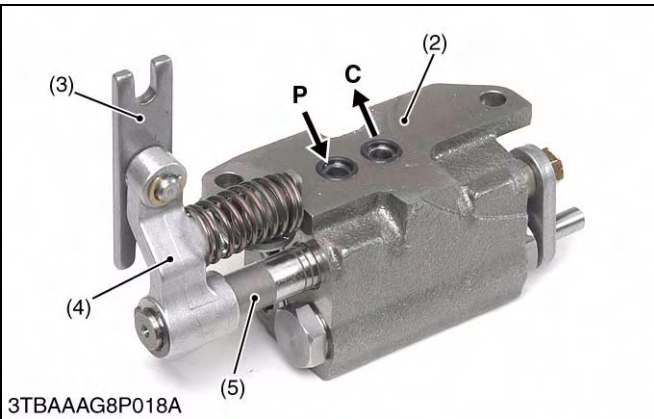
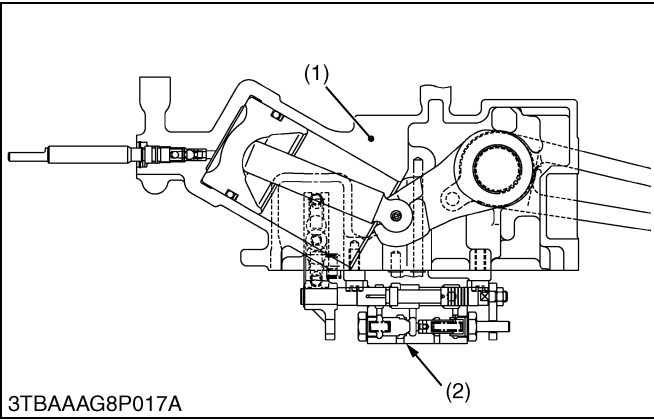

This position control valve (2) is located under the hydraulic cylinder block (1).

This control valve is mechanically connected to the position control lever with linkage.

This control valve is also mechanically connected to the lift arm with a feed back rod.

This control valve controls the oil flow forced from hydraulic pump and the oil returned back from the hydraulic cylinder.

- | | |
|------------------------------|-------------------------|
| (1) Hydraulic Cylinder Block | P: Pump Port |
| (2) Position Control Valve | C: Cylinder Port |
| (3) Link | |
| (4) Lever | |
| (5) Spool | |
| (6) Poppet | |
| (7) Poppet | |
| (8) Poppet | |
| (9) Poppet | |
| (10) Set Screw | |

9Y1210982HYM0009US0

(2) Operation

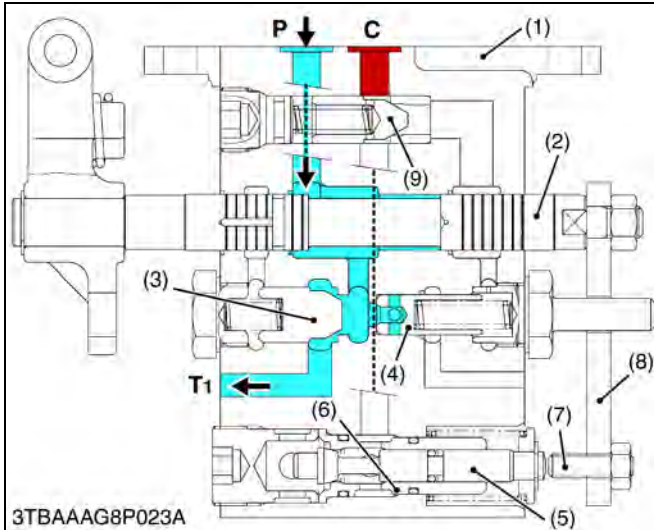

Neutral

Oil forced into the control valve through **P** port pushes and opens the unload valve (3), and then returns to the transmission case through **T1** port.

Oil behind the unload valve (3) returns to the transmission case through the groove of the spool (2).

Since the check valve (9) and the poppet 2 (5) are closed, oil in the hydraulic cylinder does not flow to the transmission case. Thus, the implement remains at its fixed position.

- (1) Valve Body
- (2) Spool
- (3) Unload Valve
- (4) Unload Poppet
- (5) Poppet 2
- (6) Sleeve
- (7) Adjusting Bolt
- (8) Connecting Plate
- (9) Check Valve

P: Pump Port
C: Cylinder Port
T1: Tank Port

9Y1210982HYM0010US0

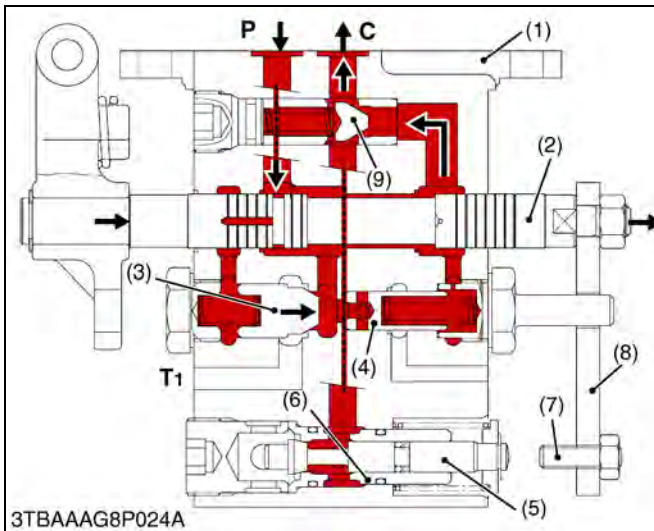

Lift

When the position control lever is set to "**LIFT**" position, the spool (2) is pushed into the valve body (1).

The oil forced into the control valve body (1) through **P** port flows to two oil circuits.

The first circuit is oil flowing to the back of the unload valve (3) to close it.

The second oil circuit is oil flowing to the check valve (9) and the hydraulic cylinder through **C** port to lift the implement.

- (1) Valve Body
- (2) Spool
- (3) Unload Valve
- (4) Unload Poppet
- (5) Poppet 2
- (6) Sleeve
- (7) Adjusting Bolt
- (8) Connecting Plate
- (9) Check Valve

P: Pump Port
C: Cylinder Port
T1: Tank Port

9Y1210982HYM0011US0

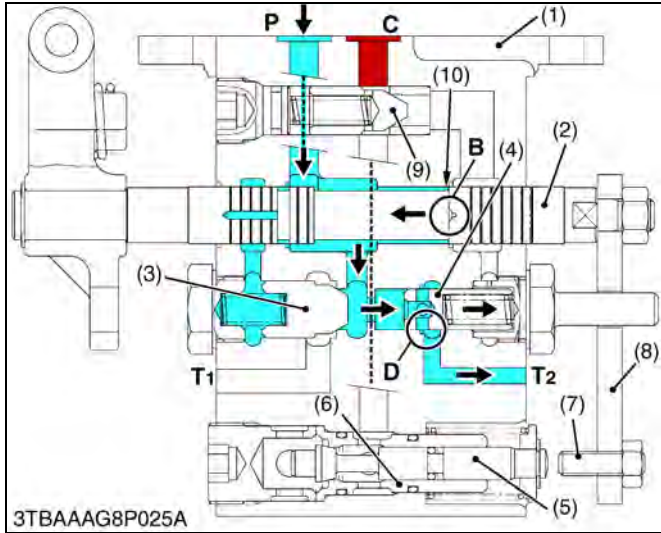

Shockless mechanism operating (Lift to Neutral)

When the implement begins to lift up, the feedback rod connected to the lift arm pushes back the spool (2) to near "NEUTRAL" position.

When the implement lifts up near the "NEUTRAL" position, quantity of oil passing through the orifice (10) is reduced.

It causes oil pressure difference between portion B and unload poppet (4).

Since oil pressure at unload poppet (4) is higher than oil pressure at portion D, oil forced from P port pushes and opens unload poppet (4), and oil drains through T2 port to transmission case.

Quantity of oil flowing through portion B is less.

Quantity of oil flowing to unload poppet (4) is greater.

It causes oil pressure increase at portion D of the unload poppet (4).

While the implement is coming to "NEUTRAL" position, quantity of oil flowing to spool (2) is reduced at portion B. And then, oil drains through unload poppet (4) to transmission case.

It causes implement's smooth stopping at "NEUTRAL" position without shock.

- | | |
|----------------------|-------------------------|
| (1) Valve Body | P: Pump Port |
| (2) Spool | B: Portion B |
| (3) Unload Valve | C: Cylinder Port |
| (4) Unload Poppet | D: Portion D |
| (5) Poppet 2 | T1: Tank Port |
| (6) Sleeve | |
| (7) Adjusting Bolt | |
| (8) Connecting Plate | |
| (9) Check Valve | |
| (10) Orifice | |

9Y1210982HYM0012US0

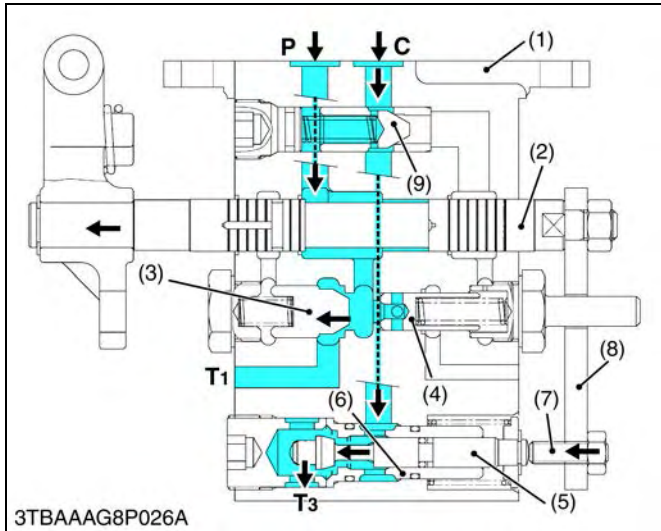

Down

When the position control lever is set to "DOWN" position, the spool (2) is pulled out from the control valve body (1).

At the same time, the adjust bolt (7) connected to the connecting plate (8) pushes the poppet (5) into the control valve body (1). And then the poppet (5) is opened.

Oil in the hydraulic cylinder is forced out from C port through and goes valve body (1) to transmission case by the weight of the implement, causing the implement to lower.

Oil forced into the control valve through P port pushes and opens the unload valve (3) and returns to the transmission case through T1 port.

- | | |
|----------------------|-------------------------|
| (1) Valve Body | P: Pump Port |
| (2) Spool | C: Cylinder Port |
| (3) Unload Valve | T1: Tank Port |
| (4) Unload Poppet | T3: Tank Port |
| (5) Poppet 2 | T4: Tank Port |
| (6) Sleeve | |
| (7) Adjusting Bolt | |
| (8) Connecting Plate | |
| (9) Check Valve | |

9Y1210982HYM0013US0

[4] FEEDBACK LINKAGE FOR POSITION CONTROL

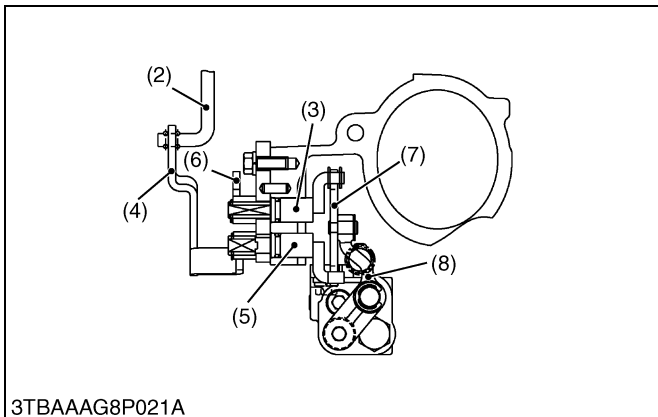
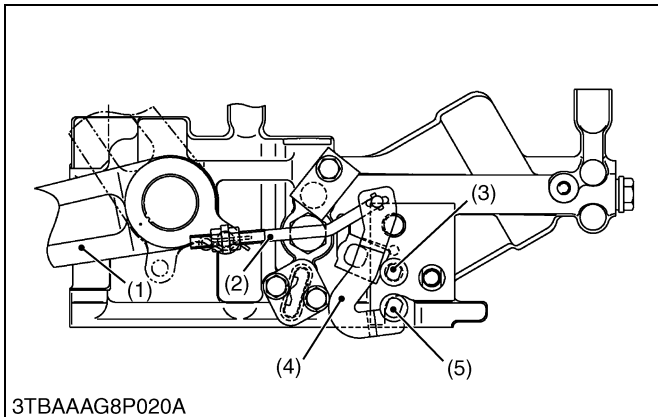
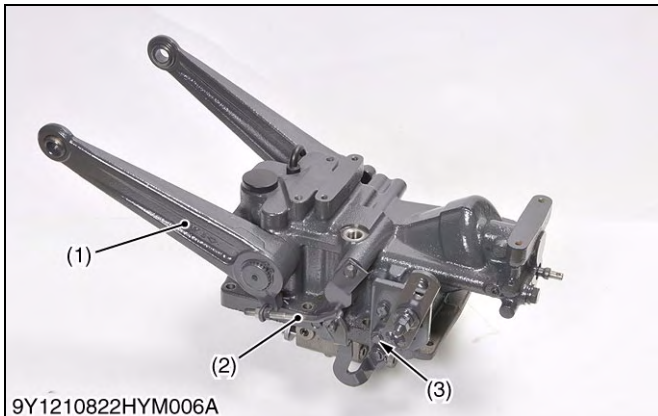

When the position control lever is moved to rearward to lift the implement, the spool of the position control valve is pushed in to form a lifting circuit by the motions of the control lever arm (6), the control lever shaft (3), the connecting arm (7) and the lever (8). After the lift arm (1) moves upward, the spool is pulled out and returns to form a neutral circuit by the motions of the feedback rod (2), the feedback arm (4), the feedback arm shaft (5), the connecting arm (7) and the lever (8).

As a result, the implement height can be easily determined in proportion to the set position of the position control lever.

- (1) Lift Arm
- (2) Feedback Rod
- (3) Control Lever Shaft
- (4) Feedback Arm
- (5) Feedback Arm Shaft
- (6) Control Lever Arm
- (7) Connecting Arm
- (8) Lever

9Y1210982HYM0014US0

4. FRONT LOADER CONTROL VALVE (IF EQUIPPED)

[1] STRUCTURE

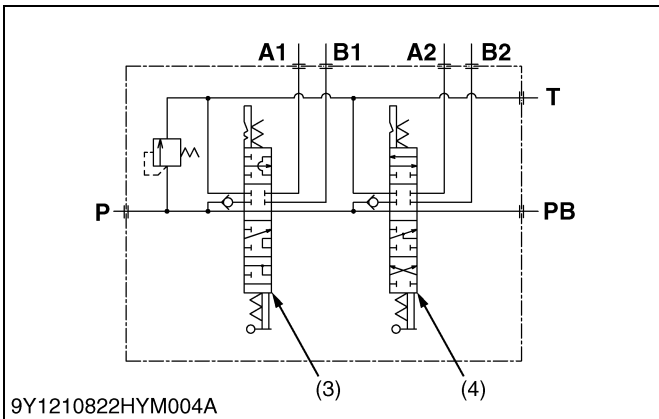
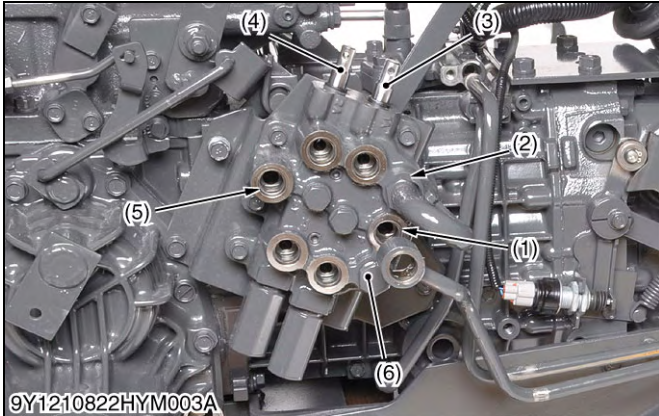

The control valve assembly consists of one casting block and four major section as shown above.

1) Inlet and Outlet Section

This section has **P** and **T** ports.

The **P** port is connected to the **OUTLET** port of hydraulic block by the hydraulic hose.

The **T** port is connected to the **TANK** port of hydraulic block by the hydraulic hose.

2) Boom Control Section

The boom control valve is consists of 4-position, 6-connection, detent, spring center type, consisting of a mono block valve housing, spool, load check valve, etc. This valve has **A1** and **B1** ports and controls oil flow to the boom cylinder.

3) Bucket Control Section

The bucket control valve is consists of 4-position, 6-connection, no detent, spring center type, consisting of a mono block valve housing, spool, load check valve, etc. This valve has **A2** and **B2** ports and controls oil flow to the bucket cylinder.

4) Power Beyond

This section has **PB** port which is connected to the **INLET** port of hydraulic block by the hydraulic hose, and feeds oil to the 3-point hitch hydraulic control valve.

- | | |
|---------------------------|--------------------|
| (1) Pump Port | P: P Port |
| (2) Tank Port | T: T Port |
| (3) Boom Control Spool | A1: A1 Port |
| (4) Bucket Control Spool | A2: A2 Port |
| (5) Power Beyond Port | B1: B1 Port |
| (6) Loader Valve Assembly | B2: B2 Port |
| | PB: PB Port |

9Y1210982HYM0015US0

[2] OPERATION

Neutral

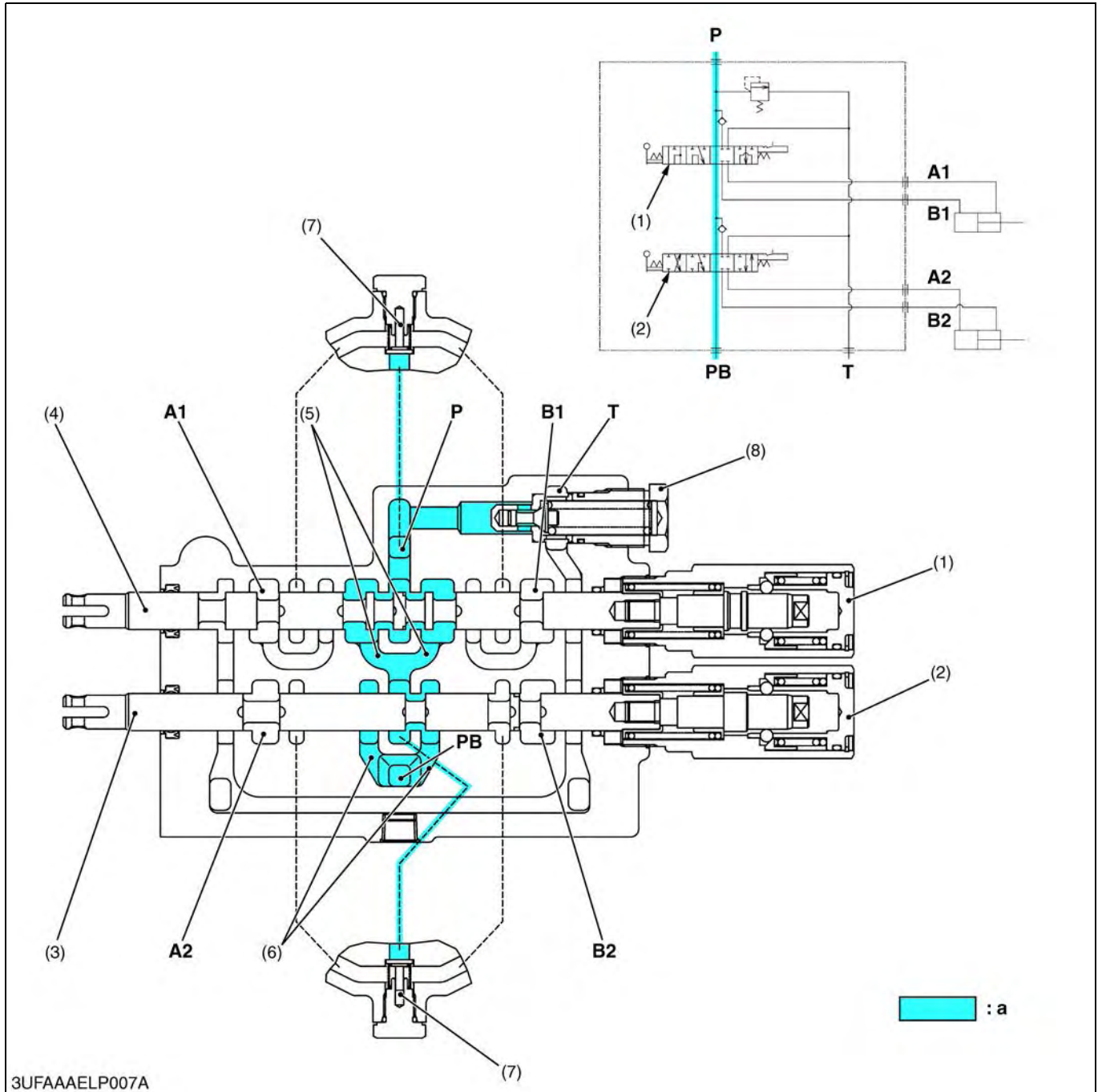

3UF AAAELP007A

- (1) Boom Control Section
- (2) Bucket Control Section
- (3) Spool
- (4) Spool

- (5) PB Passage 1
- (6) PB Passage 2
- (7) Load Check Valve
- (8) Relief Valve

- T: T Port
- P: P Port
- A1: A1 Port
- A2: A2 Port

- B1: B1 Port
- B2: B2 Port
- PB: PB Port

9Y1210982HYM0016US0

Up

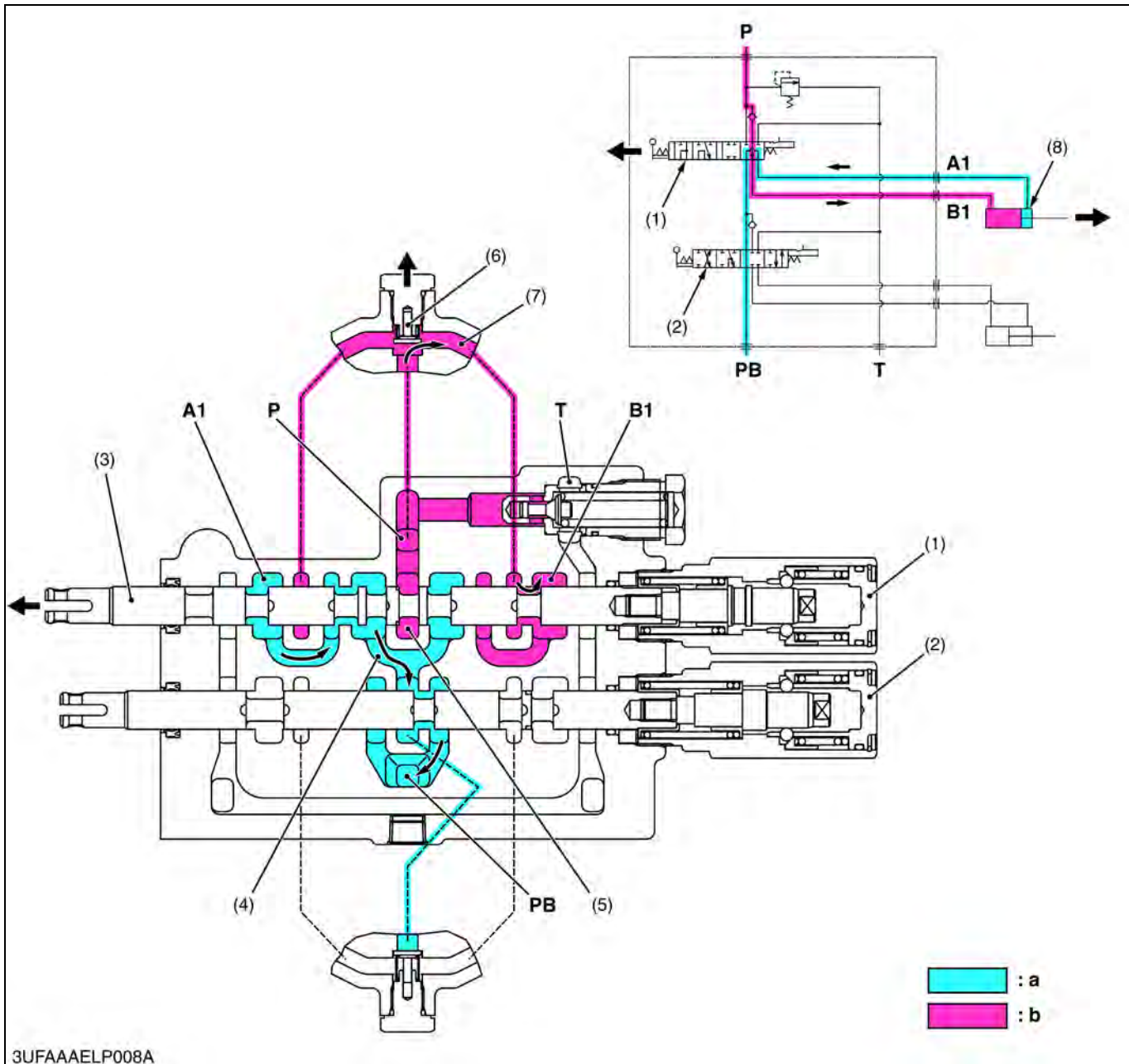

3UF AAAELP008A

- | | | | |
|----------------------------|-----------------------|------------------|---------------------------------------|
| (1) Boom Control Section | (5) Neutral Passage 1 | P: P Port | A1: A1 Port |
| (2) Bucket Control Section | (6) Load Check Valve | T: T Port | (From Boom Cylinder) |
| (3) Spool | (7) Passage 1 | | B1: B1 Port (To Boom Cylinder) |
| (4) PB Passage 1 | (8) Boom Cylinder | | PB: PB Port |
| | | | a: Low Pressure |
| | | | b: High Pressure |

1. When the hydraulic control lever is set to the "UP" position, the spool (3) of the boom control section (1) moves to the left, which forms oil passages between passage 1 (7) and B1 port, and between A1 port and PB passage 1 (4).
2. As the oil passage from the neutral passage 1 (5) to the PB passage 1 (4) is closed by the spool (3), the pressure-fed oil from the P port opens the load check valve (6) and flows through the notched section of the spool (3) and B1 port to extend the boom cylinder (8).
3. Return oil from the boom cylinder (8) flows from the A1 port through the passage in the spool (3) and PB passage 1 (4) to the bucket control section (2).

9Y1210982HYM0017US0

Down

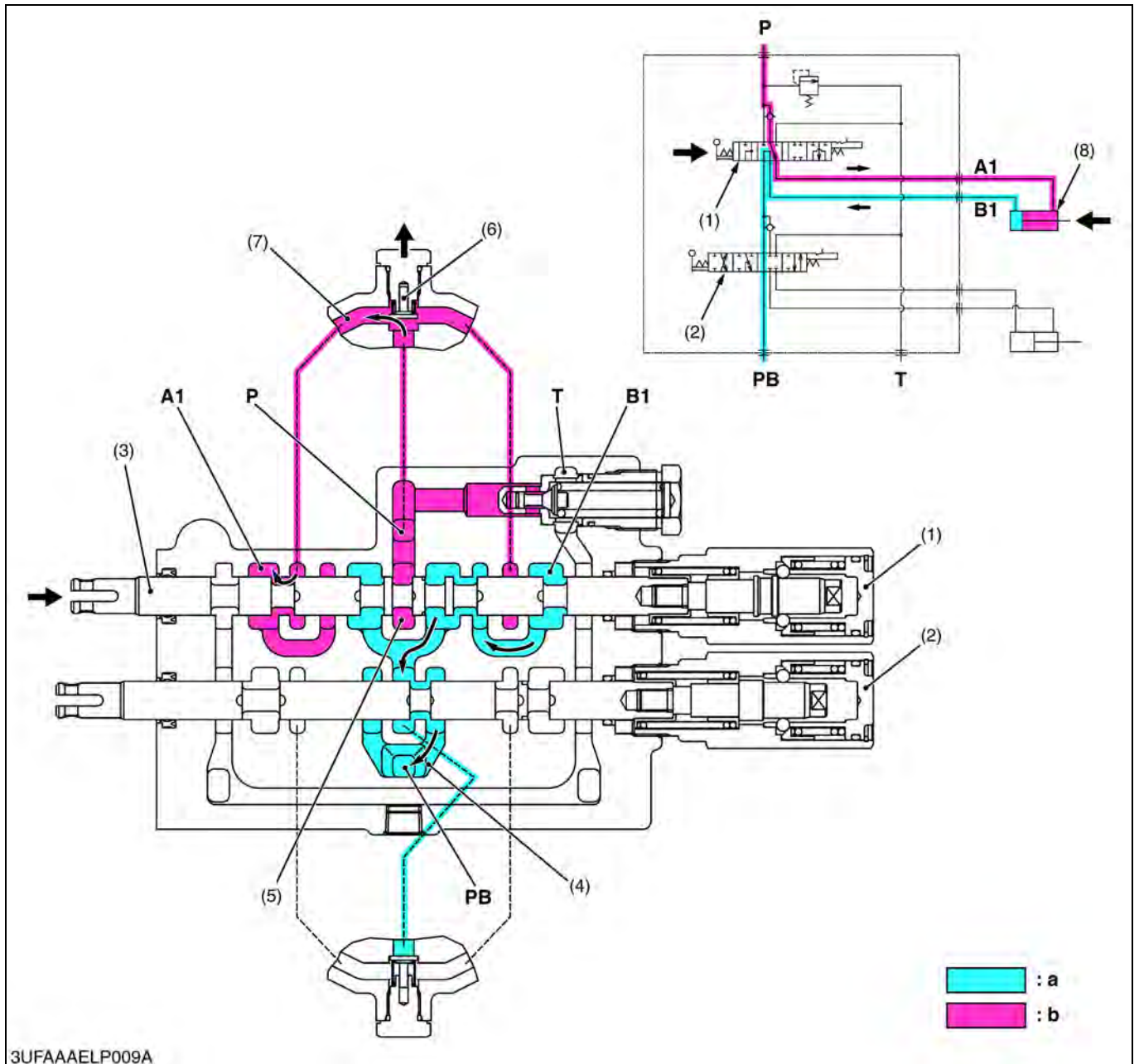

3UFAAAELP009A

- | | | | |
|----------------------------|-----------------------|------------------|---|
| (1) Boom Control Section | (5) Neutral Passage 1 | P: P Port | A1: A1 Port (To Boom Cylinder) |
| (2) Bucket Control Section | (6) Load Check Valve | T: T Port | B1: B1 Port (From Boom Cylinder) |
| (3) Spool | (7) Passage 1 | | PB: PB Port |
| (4) PB Passage 1 | (8) Boom Cylinder | | a: Low Pressure |
| | | | b: High Pressure |

1. When the hydraulic control lever is set to the "DOWN" position, the spool (3) moves to the right, which forms oil passages between passage 1 (7) and **A1** port, and between **B1** port and **PB** passage 1 (4).
2. As the oil passage from the neutral passage 1 (5) to the **PB** passage 1 (4) is closed by the spool (3), the pressure-fed oil from the **P** port opens the load check valve (6) and flows through the notched section of the spool (3) and **A1** port to retract the boom cylinder (8).
3. Return oil from the boom cylinder (8) flows from the **B1** port through the passage in the spool (3) and **PB** passage 1 (4) to the bucket control section (2).

9Y1210982HYM0018US0

Floating

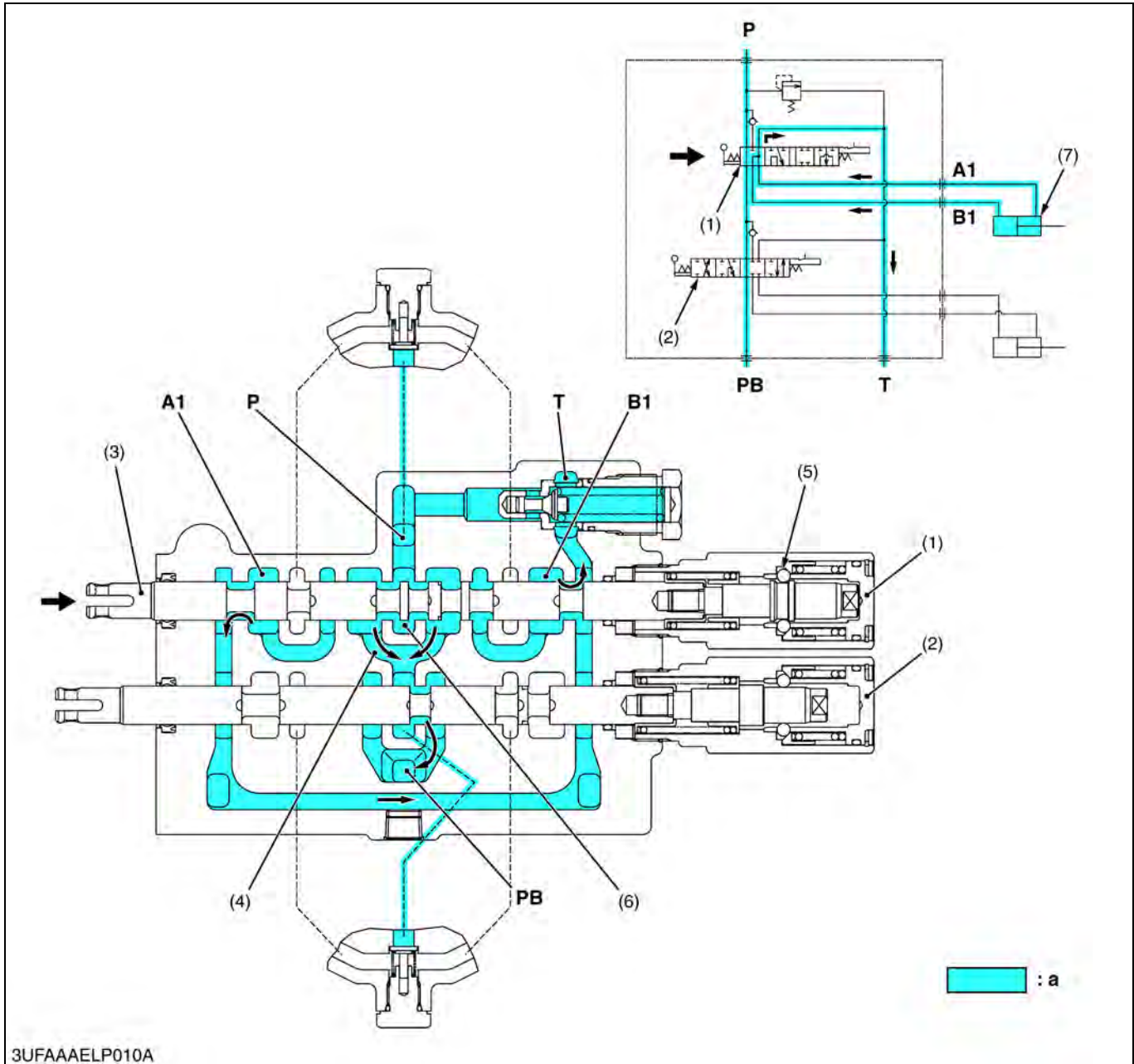

- | | | | |
|----------------------------|-----------------------|------------------|------------------------|
| (1) Boom Control Section | (5) Detent Mechanism | P: P Port | A1: A1 Port |
| (2) Bucket Control Section | (6) Neutral Passage 1 | T: T Port | B1: B1 Port |
| (3) Spool | (7) Boom Cylinder | | PB: PB Port |
| (4) PB Passage 1 | | | a: Low Pressure |

1. When the hydraulic control lever is set to the **"FLOAT"** position, the spool (3) moves further to the right from the **"DOWN"** position and is retained by the detent mechanism (5).
2. This forms oil passages among the **A1** port, **B1** port and **T** port. As a result, oil in the boom cylinder (7) flows freely from the **A1** port and **B1** port through the **T** port to the transmission case.
3. Oil entering the **P** port flows to the bucket control section (2) through the neutral passage 1 (6) and **PB** passage 1 (4).

9Y1210982HYM0019US0

Roll-back

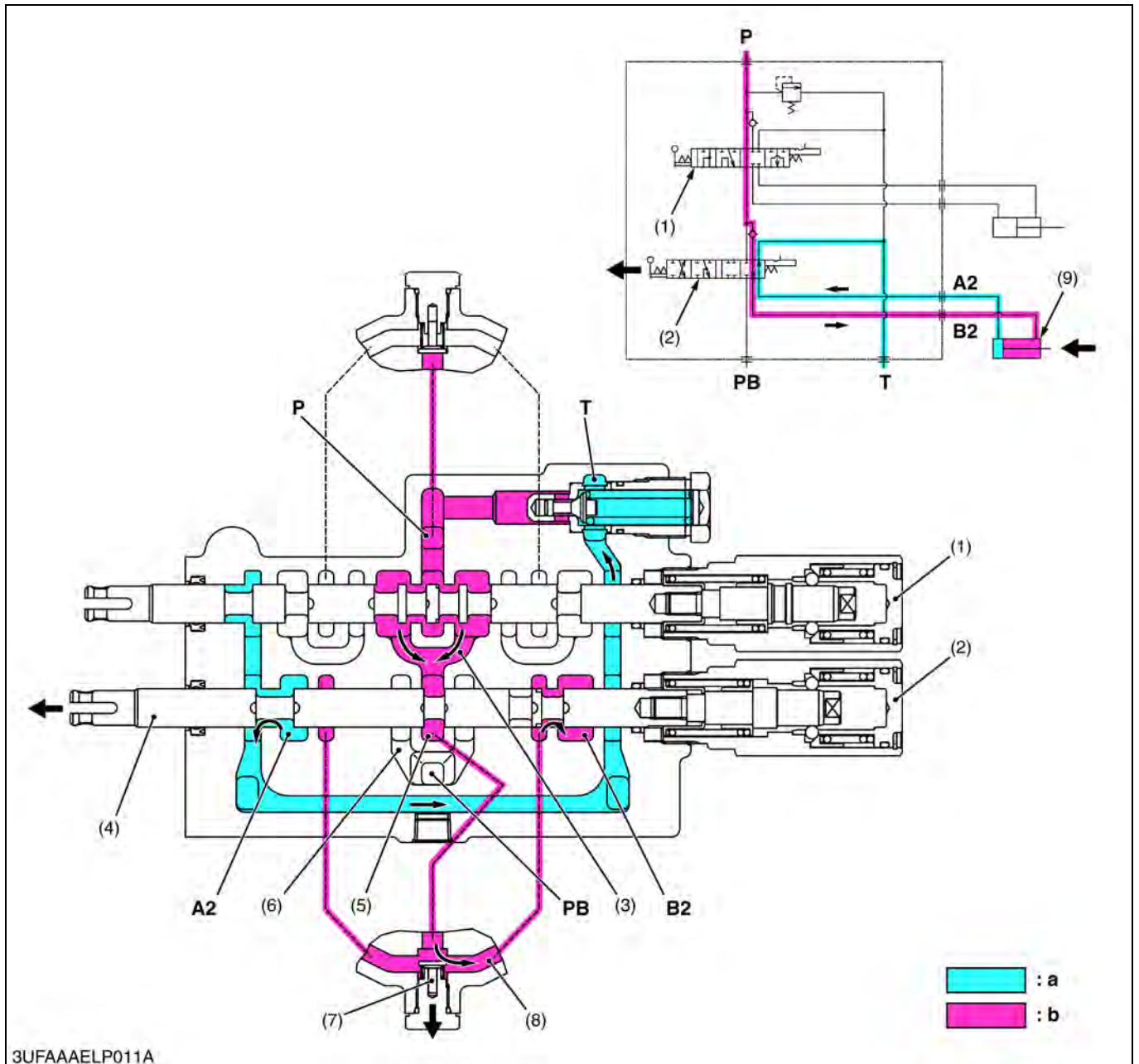

3UF AAAELP011A

- | | | | |
|----------------------------|----------------------|------------------------|-------------------------|
| (1) Boom Control Section | (6) PB Passage 2 | P: P Port | B2: B2 Port |
| (2) Bucket Control Section | (7) Load Check Valve | T: T Port | (To Bucket Cylinder) |
| (3) PB Passage 1 | (8) Passage 2 | PB: PB Port | a: Low Pressure |
| (4) Spool | (9) Bucket Cylinder | A2: A2 Port | b: High Pressure |
| (5) Neutral Passage 2 | | (From Bucket Cylinder) | |

1. When the hydraulic control lever is set to the "ROLL-BACK" position, the spool (4) of the bucket control section (2) moves to the left, which forms oil passages between passage 2 (8) and B2 port, and between A2 port and T port.
2. The pressure-fed oil from the P port flows to the neutral passage 2 (5) through the boom control section (1) and PB passage 1 (3). As the oil passage from the neutral passage 2 (5) to the PB passage 2 (6) is closed by the spool (4), this oil opens the load check valve (7), and flows through the notched section of the spool (4) and B2 port to retract the bucket cylinder (9).
3. Return oil from the bucket cylinder (9) flows to the transmission case through the A2 port and T port.

9Y1210982HYM0020US0

Dump 1

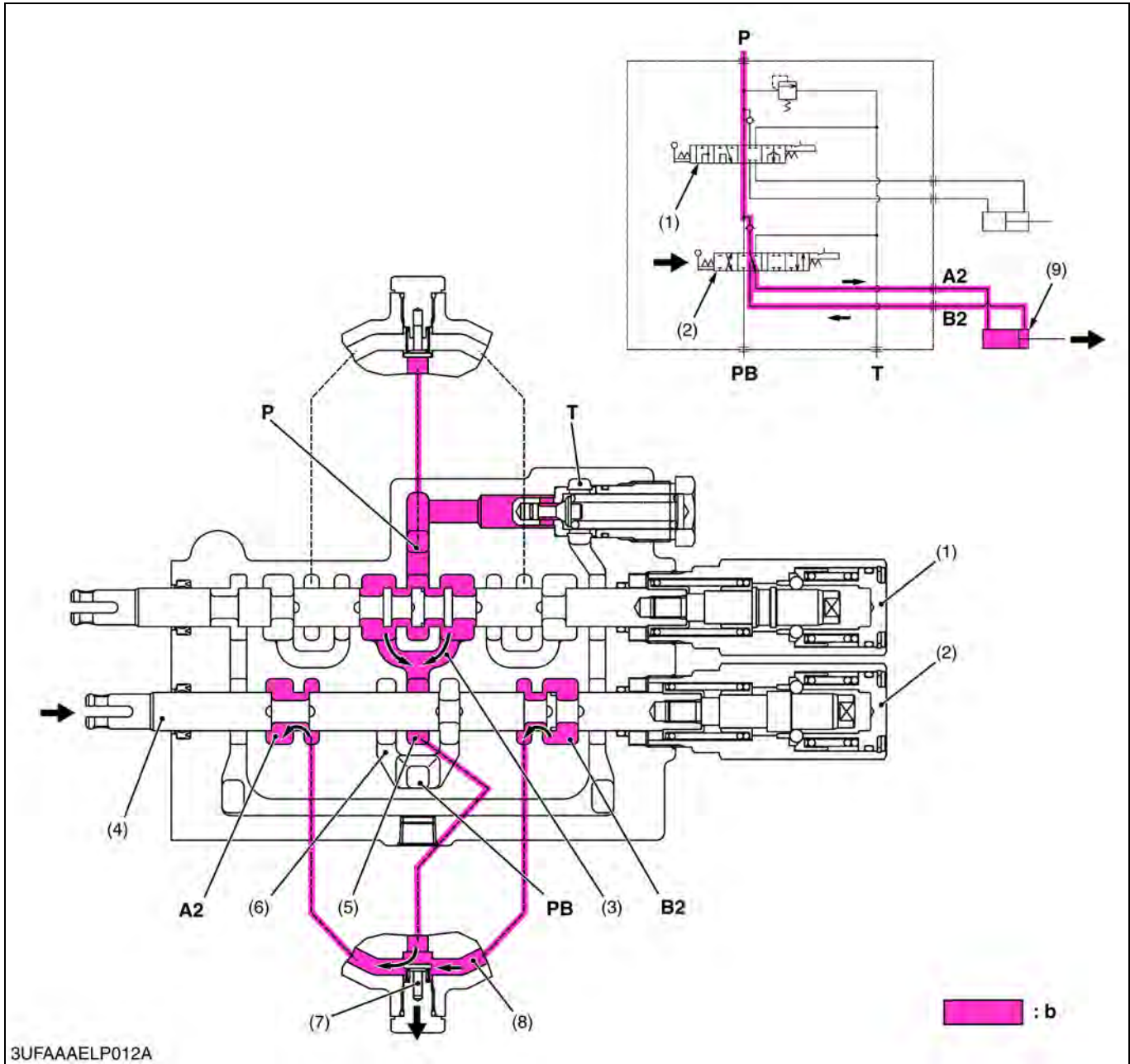

3UFAAAELP012A

- | | | | |
|----------------------------|----------------------|--------------------|-------------------------|
| (1) Boom Control Section | (6) PB Passage 2 | P: P Port | A2: A2 Port |
| (2) Bucket Control Section | (7) Load Check Valve | T: T Port | (To Bucket Cylinder) |
| (3) PB Passage 1 | (8) Passage 2 | PB: PB Port | B2: B2 Port |
| (4) Spool | (9) Bucket Cylinder | | (From Bucket Cylinder) |
| (5) Neutral Passage 2 | | | b: High Pressure |
- When the hydraulic control lever is set to the "DUMP 1" position, the spool (4), which forms oil passages among passage 2 (8), **A2** port and **B2** port.
 - The pressure-fed oil from the **P** port flows through the boom control valve, opens the load check valve, and flows to the bucket cylinder to extend the cylinder through the notched section of the spool and **A2** port.
 - Return oil from the bucket cylinder (9) flows from the **B2** port to the passage 2 (8), and flows to the **A2** port together with the pressure-fed oil from the **P** port. As a result, the dump speed is increased.
- (Reference)**
- The oil pressure of the **A2** port and **B2** port is identical, but the bucket cylinder extend by the difference of received pressure area (cylinder rod part).

9Y1210982HYM0021US0

Dump 2

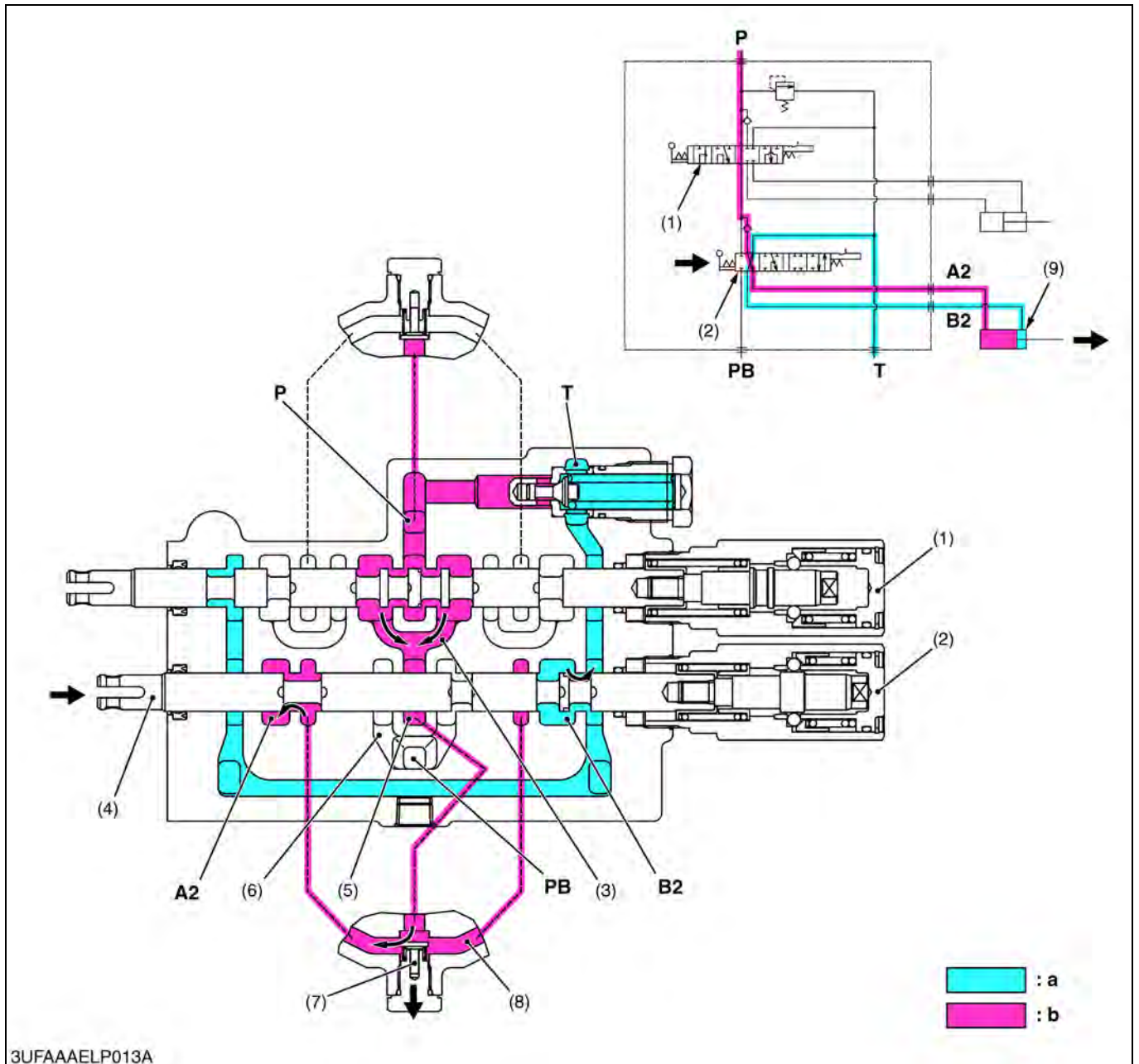

3UF AAAELP013A

- | | | | |
|----------------------------|-------------------------|--------------------|-------------------------|
| (1) Boom Control Section | (6) PB Passage 2 | P: P Port | A2: A2 Port |
| (2) Bucket Control Section | (7) Load Check Valve | T: T Port | (To Bucket Cylinder) |
| (3) PB Passage 1 | (8) Passage 2 | PB: PB Port | B2: B2 Port |
| (4) Spool | (9) Bucket Cylinder | | (From Bucket Cylinder) |
| (5) Neutral Passage 2 | | | a: Low Pressure |
| | | | b: High Pressure |

- When the hydraulic control lever is set to the **"DUMP 2"** position, the spool (4) of the bucket control section (2) moves further to the right from the **"DUMP 1"** position, which forms oil passages between passage 2 (8) and **A2** port, and between **B2** port and **T** port.
- The pressure-fed oil from the **P** port flows to the neutral passage 2 (5) through the boom control section (1) and **PB** passage 1 (3). As the oil passage from the neutral passage 2 (5) to the **PB** passage 2 (6) is closed by the spool (4), this oil opens the load check valve (7) and flows through the notched section of the spool (4) and **B2** port to extend the bucket cylinder (9).
- Return oil from the bucket cylinder (9) flows to the transmission case through the **B2** port and **T** port.

9Y1210982HYM0022US0

5. REMOTE CONTROL VALVE (IF EQUIPPED)

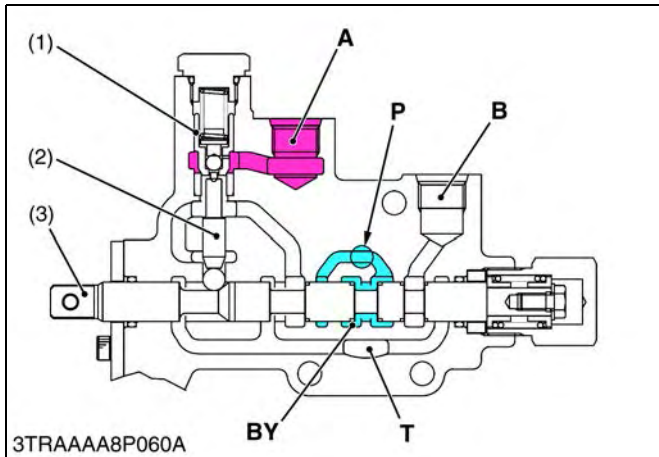

Neutral

Pressure-fed oil from the hydraulic pump is delivered into the **P** port, and flows to the rear hydraulic outlet through **BY** port.

At this time, oil from **A** port to the **T** port is blocked by the mechanical check valve (Poppet (1)). Therefore the position of implement is kept at the set position.

- (1) Poppet
- (2) Piston
- (3) Spool

- P:** Pump Port
- T:** Tank Port
- BY:** BY Port (To Position Control Valve)
- A:** A Port
- B:** B Port

9Y1210982HYM0023US0

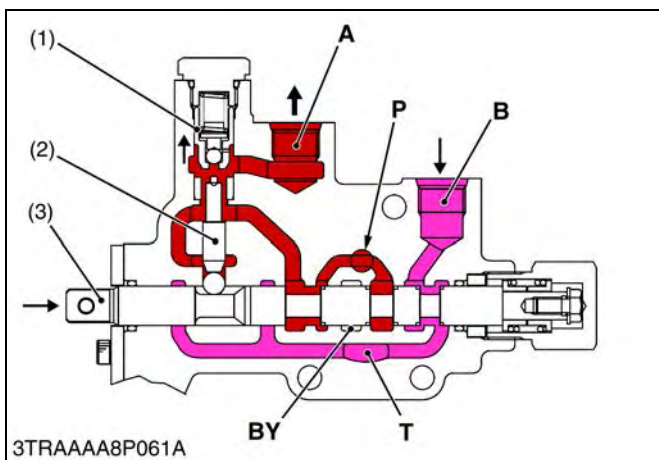

Lift

When the remote control valve operating lever is set to **LIFT** position, the spool (3) moves to the right and the passage from **P** port to the **BY** port is blocked by the spool (3).

Then the pressure-fed oil open the poppet (1) and flow through the **A** port to the hydraulic cylinder to lift the implement.

- (1) Poppet
- (2) Piston
- (3) Spool

- P:** Pump Port
- T:** Tank Port
(To Transmission Case)
- BY:** BY Port
- A:** A Port
- B:** B Port

9Y1210982HYM0024US0

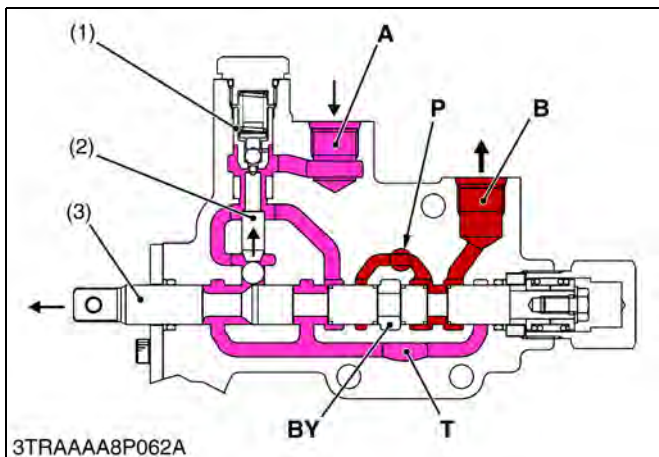

Down

When the remote control valve operating lever is set to **DOWN** position, the spool (3) moves to the left and the passage from **P** port to the **BY** port is blocked by the spool (3). At the same time, the piston (2) and poppet (1) moves upward, and open the passage from **A** port to **T** port.

Then the pressure-fed oil flow through the **B** port to the hydraulic cylinder to lower the implement. Return oil from hydraulic cylinder flows from **A** port to the transmission case.

- (1) Poppet
- (2) Piston
- (3) Spool

- P:** Pump Port
- T:** Tank Port
(To Transmission Case)
- BY:** BY Port
- A:** A Port
- B:** B Port

9Y1210982HYM0025US0

6. HYDRAULIC OUTLET

[1] MANUAL TRANSMISSION MODEL

(1) Front Hydraulic Outlet

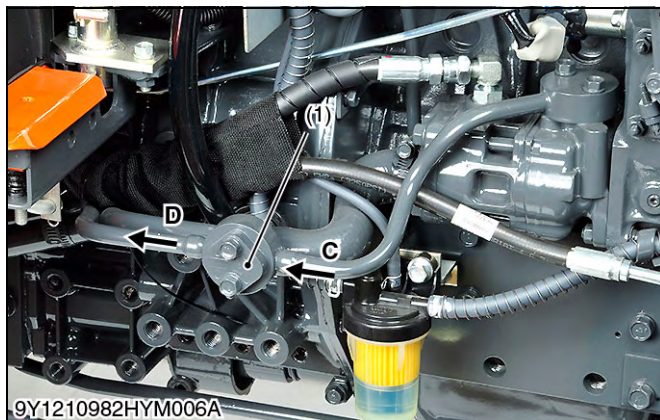

The hydraulic block type outlet is located at the right hand side of the engine.

This hydraulic block type outlet is provided to take power out from the tractor to operate the hydraulic cylinders on the implement, such as front end loader, front blade and so on.

- (1) Hydraulic Block Cover
- (2) O-Ring
- (3) Delivery Pipe

- A: To Implement**
- B: From Implement**
- C: From Hydraulic Pump**
- D: To Control Valve**

9Y1210982HYM0026US0

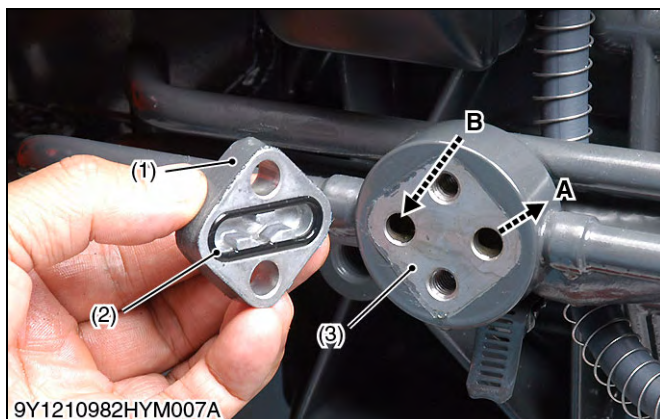

(2) Rear Hydraulic Outlet

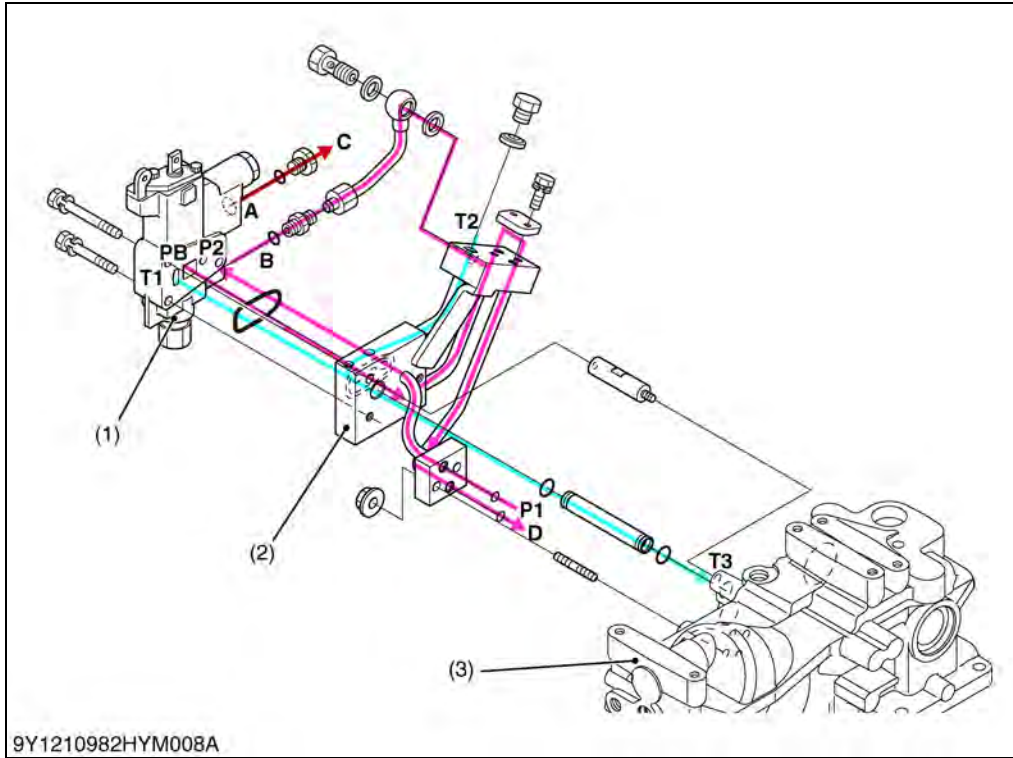

- (1) Auxiliary Control Valve
- (2) Rear Hydraulic Outlet
- (3) Hydraulic Cylinder Body

- A: From A Port of Remote Control Valve
- B: From B Port of Remote Control Valve
- C: To Implement
- D: To Position Control Valve
- P1: From Hydraulic Pump
- P2: To P Port of Remote Control Valve
- PB: To PB Port of Remote Control Valve
- T1: From T Port of Remote Control Valve
- T2: From Implement (Drain)
- T3: To Transmission Case

9Y1210982HYM008A

The rear hydraulic outlet is located at the right hand side of the hydraulic cylinder body.

This rear hydraulic outlet is provided to take power out from the tractor to operate the hydraulic cylinders on the implement.

9Y1210982HYM0027US0

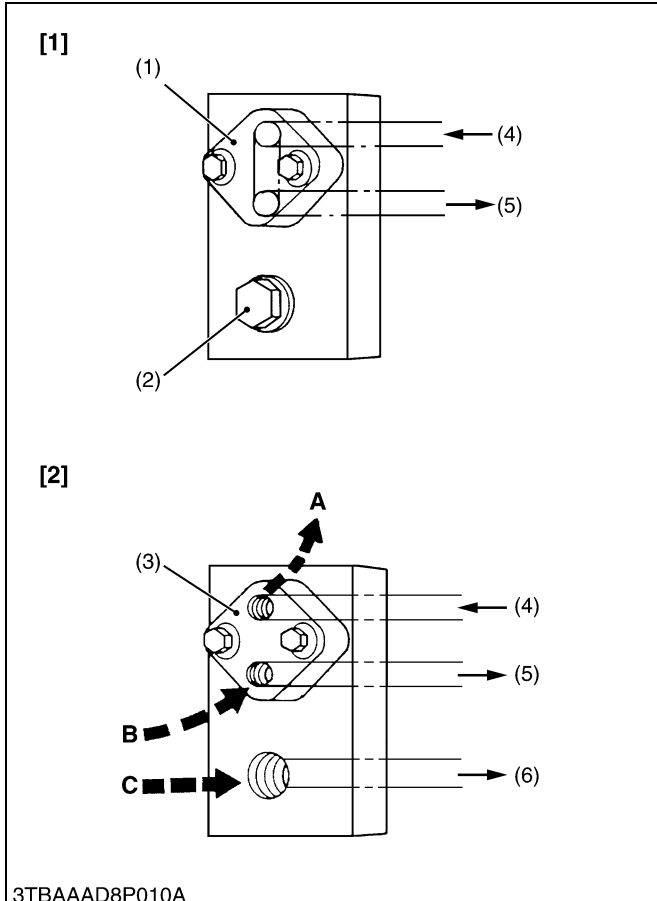

NOTE

- If the control valve of implement has the relief valve, the tank port flow from implement should be connected to the port C.

- (1) Block Cover
- (2) Plug
- (3) Block Outlet Cover (Option)
- (4) From Hydraulic Pump
- (5) To Position Control Valve
- (6) To Transmission Case

- A: To implement (Inlet) Max. flow 17 L/min. (4.5 U.S.gals/min., 3.7 Imp.gals/min.)
- Max. pressure 13.2 to 13.7 MPa (135 to 140 kgf/cm², 1920 to 1992 psi)
- B: From Implement (Outlet)
- C: From Implement (Drain)

- [1] When implement is not attached
- [2] When implement is attached

9Y1210982HYM0028US0

3TBAAAD8P010A

[2] HST MODEL

(1) Rear Hydraulic Outlet



The hydraulic block type outlet is located at the right hand side of the engine.

This hydraulic block type outlet is provided to take power out from the tractor to operate the hydraulic cylinders on the implement.

- (1) Hydraulic Block Cover
- A: From Hydraulic Pump**
- B: To Control Valve**

9Y1210982HYM0029US0

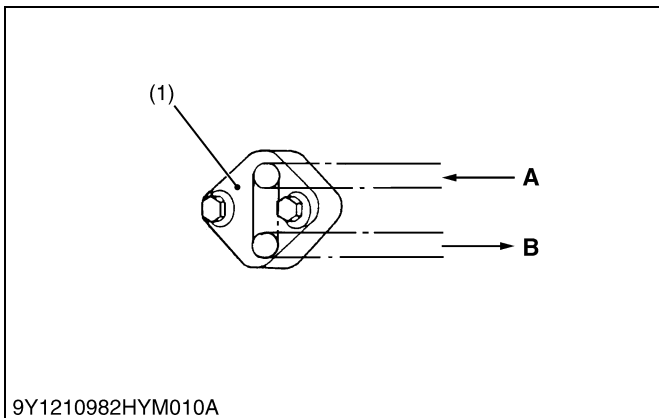

SERVICING

CONTENTS

1. TROUBLESHOOTING.....	8-S1
2. SERVICING SPECIFICATIONS.....	8-S3
3. TIGHTENING TORQUES.....	8-S5
4. CHECKING, DISASSEMBLING AND SERVICING.....	8-S6
[1] CHECKING AND ADJUSTING.....	8-S6
(1) Hydraulic Pump (For 3-Point Hitch Hydraulic System).....	8-S6
(2) Hydraulic Pump (For Power Steering, Bi-speed Turn, PTO Clutch and HST).....	8-S8
(3) 3-Points Hitch Relief Valve.....	8-S10
(4) Lift Arm.....	8-S11
[2] DISASSEMBLING AND ASSEMBLING.....	8-S11
(1) Hydraulic Pump.....	8-S11
(2) 3-Point Hitch.....	8-S13
(3) Separating Hydraulic Cylinder From Tractor Body (ROPS Model).....	8-S13
(4) Separating Hydraulic Cylinder From Tractor Body (CABIN Model).....	8-S14
(5) 3-Points Hitch: Hydraulic Cylinder.....	8-S15
(6) Front Loader Control Valve Assembly (If Equipped).....	8-S19
(7) Remote Control Valve (If Equipped).....	8-S22
[3] SERVICING.....	8-S22

1. TROUBLESHOOTING

Symptom	Probable Cause and Checking Procedure	Solution	Reference Page
Implement Does Not Rise (No Noise)	1. Transmission fluid improper	Check transmission oil	G-8
	2. Hydraulic pump malfunctioning	Solution order 1. Check hydraulic flow test	8-S8
		2. Replace hydraulic pump	8-S11
	3. Relief valve malfunctioning	Solution order 1. Check relief valve	8-S10
		2. Check or adjust relief valve	8-S10
		3. Replace relief valve	8-S10
	4. Piston O-ring or cylinder damaged	Replace O-ring or cylinder	8-S21
	5. Control valve malfunctioning	Replace control valve	8-S16
6. Control valve improperly adjusted	Check or adjust control valve	8-S19	
7. Control valve improperly assembled	Repair control valve	8-S19	
Implement Does Not Rise (Noise)	1. Transmission fluid improper	Check transmission oil	G-8
	2. Oil filter cartridge clogged	Replace oil filter cartridge	G-30, G-35
	3. Suction pipe loosen or broken	Check or repair suction pipe	8-S11
	4. Suction pipe connecting hose loosen or broken	Check or repair suction hose	8-S11
	5. Suction pipe O-ring broken	Check or replace O-ring	8-S11
	6. Relief valve setting pressure too low	Solution order 1. Check relief valve	8-S10
		2. Check or adjust relief valve	8-S10
		3. Replace relief valve	8-S10
7. Hydraulic pump broken	Solution order 1. Check hydraulic flow test	8-S8	
	2. Replace hydraulic pump	8-S11	
Implement Does Not Reach Maximum Height	1. Feedback rod improperly adjusted	Solution order 1. Check lift arm free play	8-S11
		2. Adjust feedback rod	8-S11
Implement Does Not Lower	1. Control valve malfunctioning	Replace control valve	8-S16

Symptom	Probable Cause and Checking Procedure	Solution	Reference Page
Implement Drops by Its Weight	1. Piston O-ring worn or damaged	Replace O-ring or cylinder	8-S21
	2. Control valve malfunctioning	Replace control valve	8-S16

9Y1210982HYS0037US0

2. SERVICING SPECIFICATIONS

Item		Factory Specification	Allowable Limit
Hydraulic Pump (For 3-Point Hitch) Condition [Manual Transmission Model] <ul style="list-style-type: none"> Engine rated speed : 2500 min⁻¹ (rpm) Rated pressure 15.5 to 16.5 MPa 158 to 168 kgf/cm² 2248 to 2390 psi Oil temperature : 50 °C (122 °F) [HST Model] <ul style="list-style-type: none"> Engine rated speed : 2500 min⁻¹ (rpm) Rated pressure 16.5 to 16.9 MPa 169 to 172 kgf/cm² 2400 to 2450 psi Oil temperature : 50 °C (122 °F) 	Delivery (At No Pressure)	Above 18.7 L/min. 4.94 U.S. gals/min. 4.11 Imp. gals/min.	–
	Delivery (At Rated Pressure)	Above 18.3 L/min. 4.83 U.S. gals/min. 4.03 Imp. gals/min.	Above 15.3 L/min. 4.04 U.S. gals/min. 3.37 Imp. gals/min.
Hydraulic Pump (For Power Steering, Bi-speed Turn, PTO Clutch and HST) Condition <ul style="list-style-type: none"> Engine rated speed : 2500 min⁻¹ (rpm) Rated pressure 11.5 to 12.5 MPa 118 to 127 kgf/cm² 1670 to 1810 psi Oil temperature : 50 °C (122 °F) 	Delivery (At No Pressure)	Above 14.1 L/min. 3.72 U.S. gals/min. 3.10 Imp gals/min.	–
	Delivery (At Rated Pressure)	Above 13.8 L/min. 3.65 U.S. gals/min. 3.04 Imp. gals/min.	Above 11.5 L/min. 3.04 U.S. gals/min. 2.53 Imp. gals/min.
Relief Valve (Manual Transmission Model) Condition <ul style="list-style-type: none"> Engine rated speed : 2500 min⁻¹ (rpm) Oil temperature : 50 °C (122 °F) 	Setting Pressure	15.5 to 16.5 MPa 158 to 168 kgf/cm ² 2248 to 2393 psi	–
Relief Valve (HST Model) Condition <ul style="list-style-type: none"> Engine rated speed : 2500 min⁻¹ (rpm) Oil temperature : 50 °C (122 °F) 	Setting Pressure	16.5 to 16.9 MPa 169 to 172 kgf/cm ² 2400 to 2450 psi	–
Lift Arm	Free Play	5 to 15 mm 0.20 to 0.59 in.	–
Tip of Gear Tooth to Casing	Clearance	–	0.15 mm 0.0059 in.
Bushing to Shaft <ul style="list-style-type: none"> Shaft Bushing 	Clearance	0.020 to 0.091 mm 0.0008 to 0.0036 in.	0.12 mm 0.0047 in.
	O.D.	14.970 to 14.980 mm 0.5894 to 0.5898 in.	–
	I.D.	15.000 to 15.061 mm 0.5906 to 0.5930 in.	–
Side Plate	Thickness	2.48 to 2.50 mm 0.0976 to 0.0984 in.	2.40 mm 0.0945 in.
Hydraulic Cylinder	I.D.	75.05 to 75.10 mm 2.955 to 2.956 in.	75.15 mm 2.959 in.

Item		Factory Specification	Allowable Limit
Hydraulic Arm Shaft to Bushing	Clearance	0.020 to 0.110 mm 0.0008 to 0.0043 in.	0.30 mm 0.0118 in.
• Hydraulic Arm Shaft (Right)	O.D.	37.925 to 37.950 mm 1.4931 to 1.4941 in.	–
• Hydraulic Arm Shaft (Left)	O.D.	34.925 to 34.950 mm 1.3750 to 1.3759 in.	–
• Bushing (Right)	I.D.	37.970 to 38.035 mm 1.4949 to 1.4974 in.	–
• Bushing (Left)	I.D.	34.970 to 35.035 mm 1.3768 to 1.3793 in.	–

9Y1210982HYS0002US0

3. TIGHTENING TORQUES

Tightening torques of screws, bolts and nuts on the table below are especially specified.
(For general use screws, bolts and nuts: See page G-10.)

Item	N·m	kgf·m	lbf·ft
Hydraulic pump cover mounting screw	35 to 39	3.5 to 4.0	26 to 28
Set bolt of the lower link pin	15 to 20	1.6 to 2.0	11 to 14
Lock nut of the lower link pin	43 to 47	4.4 to 4.7	32 to 34
Relief valve plug (Manual Transmission Model)	49.1 to 68.6	5.0 to 7.0	36.2 to 50.6
Rear wheel mounting nut and screw (B2050, B2350, B2650)	108 to 126	11.1 to 12.8	79.7 to 92.9
Rear wheel mounting nut (B3150)	167 to 191	17 to 19.5	123 to 141
Rear wheel mounting screw (B3150)	196 to 225	20 to 23	145 to 166
Front loader valve pipe joint bolt	48 to 70	4.9 to 7.1	36 to 51
3-point hitch delivery pipe 1 joint bolt	48 to 70	4.9 to 7.1	36 to 51
3-point hitch delivery pipe 2 joint bolt (Front loader valve side)	48 to 70	4.9 to 7.1	36 to 51
3-point hitch delivery pipe 2 joint bolt (Hydraulic cylinder case side)	50 to 60	5.1 to 6.1	37 to 44
Plug 1 (Remote control valve)	29.4 to 49.0	3.0 to 5.0	21.7 to 36.2
Bracket mounting screw (Remote control valve)	4.9 to 7.8	0.5 to 0.8	3.6 to 5.8
Plug 2 (Remote control valve)	39.3 to 58.8	4.0 to 6.0	28.9 to 43.4

9Y1210982HYS0003US0

4. CHECKING, DISASSEMBLING AND SERVICING

[1] CHECKING AND ADJUSTING

(1) Hydraulic Pump (For 3-Point Hitch Hydraulic System)

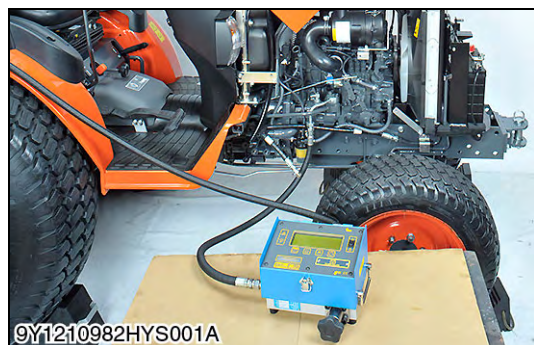
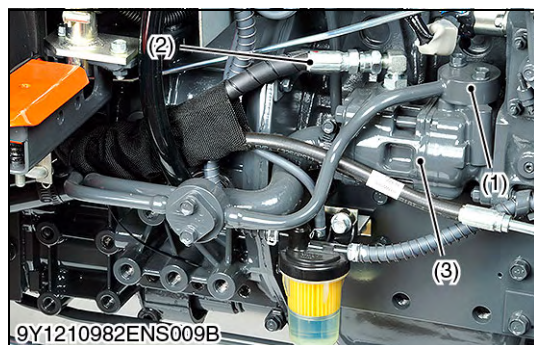

Test Preparation (For 3-Point Hitch)

■ IMPORTANT

- When using a flowmeter other than KUBOTA specified flowmeter (Code No. 07916-52792), be sure to use the instructions with that flowmeter.
- In this hook-up, there is no relief valve. Therefore while testing, do not close the flowmeter loading valve completely.

1. Disconnect the delivery pipe (1).
2. Install the flowmeter adaptor to the hydraulic pump body.
3. Connect the hydraulic test hose (Code No. 07916-52651) to the flowmeter (Code No. 07916-52791) inlet port and the adaptor 61 on the hydraulic pump body.
4. Connect the another hydraulic test hose to flowmeter outlet port and transmission oil filling port, firmly.
5. Open the flowmeter loading valve completely. (Turn counterclockwise)
6. Start the engine and set the engine speed at 2500 min⁻¹ (rpm).
7. Slowly close the loading valve to generate the pressure approximately 13.7 MPa (140 kgf/cm², 1991 psi).
8. Hold this condition until the oil temperature reaches approximately 50 °C (122 °F).

- (1) Delivery Pipe (to 3-Point Hitch) (3) Hydraulic Pump
(2) Delivery Hose (to Power Steering)

9Y1210982HYS0004US0

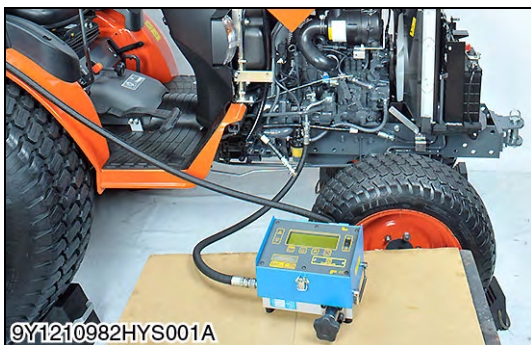

9Y1210982HYS001A

Hydraulic Pump Test (For 3-Point Hitch)

■ **NOTE**

- **Before pump testing, do the "Test Preparation".**
- 1. Open the flowmeter loading valve completely (Turn counterclockwise).
- 2. Start the engine and set at approx. 2500 min⁻¹ (rpm).
- 3. Read and note the pump delivery at no pressure.
- 4. Slowly close the loading valve to increase the pressure to the rated pressure as shown in the table below.
- 5. Read and note the pump delivery at rated pressure.
- 6. Open the loading valve and stop the engine.
- 7. If the pump delivery does not reach the allowable limit, check the pump suction line, oil filter or hydraulic pump.

(Reference)

Hydraulic pump delivery at no pressure	Factory specification	Above 18.7 L/min. 4.94 U.S. gals/min. 4.11 Imp. gals/min.
Hydraulic pump delivery at rated pressure	Factory specification	Above 18.3 L/min. 4.83 U.S. gals/min. 4.03 Imp. gals/min.
	Allowable limit	Above 15.3 L/min. 4.04 U.S. gals/min. 3.37 Imp. gals/min.

Condition

[Manual Transmission Model]

- Engine rated speed
2500 min⁻¹ (rpm)
- Rated pressure
15.5 to 16.5 MPa
158 to 168 kgf/cm²
2248 to 2390 psi
- Oil temperature
50 °C (122 °F)

[HST Model]

- Engine rated speed
2500 min⁻¹ (rpm)
- Rated pressure
16.5 to 16.9 MPa
169 to 172 kgf/cm²
2400 to 2450 psi
- Oil temperature
50 °C (122 °F)

9Y1210982HYS0005US0

(2) Hydraulic Pump (For Power Steering, Bi-speed Turn, PTO Clutch and HST)

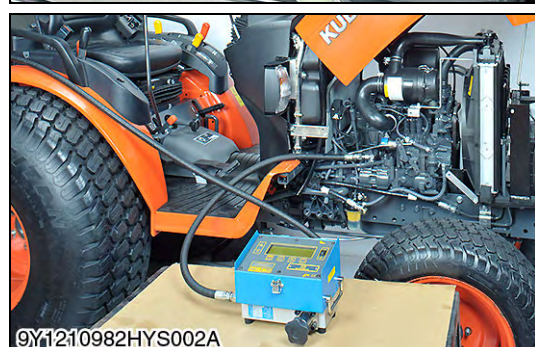
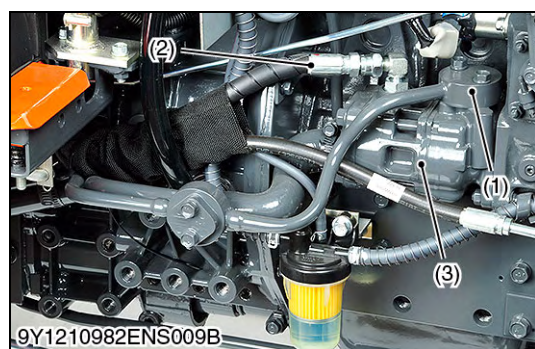

Test Preparation (For Power Steering, Bi-speed Turn, PTO Clutch and HST)

■ IMPORTANT

- When using a flowmeter other than KUBOTA specified flowmeter (Code No. 07916-52792), be sure to use the instructions with that flowmeter.
- In this hook-up, there is no relief valve. Therefore while testing, do not close the flowmeter loading valve completely.

1. Disconnect the delivery hose (2).
2. Install the flowmeter adaptor to the hydraulic pump body.
3. Connect the hydraulic test hose (Code No. 07916-52651) to the flowmeter (Code No. 07916-52791) inlet port and the adaptor **51** on the hydraulic pump body.
4. Connect the another hydraulic test hose to flowmeter outlet port and transmission oil filling port, firmly.
5. Open the flowmeter loading valve completely. (Turn counterclockwise)
6. Start the engine and set the engine speed at 2500 min⁻¹(rpm).
7. Slowly close the loading valve to generate the pressure approximately 13.7 MPa (140 kgf/cm², 1991 psi).
8. Hold this condition until the oil temperature reaches approximately 50 °C (122 °F).

- (1) Delivery Pipe (to 3-Point Hitch) (3) Hydraulic Pump
(2) Delivery Hose (to Power Steering)

9Y1210982HYS0006US0



Hydraulic Pump Test (For Power Steering, Bi-speed Turn, PTO Clutch and HST)

NOTE

- Before pump testing, do the "Test Preparation".
- 1. Open the flowmeter loading valve completely (Turn counterclockwise).
- 2. Start the engine and set at approx. 2500 min⁻¹ (rpm).
- 3. Read and note the pump delivery at no pressure.
- 4. Slowly close the loading valve to increase the pressure to the rated pressure as shown in the table below.
- 5. Read and note the pump delivery at rated pressure.
- 6. Open the loading valve and stop the engine.
- 7. If the pump delivery does not reach the allowable limit, check the pump suction line, oil filter or hydraulic pump.

(Reference)

Hydraulic pump delivery at no pressure	Factory specification	Above 14.1 L/min. 3.72 U.S. gals/min. 3.10 Imp gals/min.
Hydraulic pump delivery at rated pressure	Factory specification	Above 13.8 L/min. 3.65 U.S. gals/min. 3.04 Imp. gals/min.
	Allowable limit	Above 11.5 L/min. 3.04 U.S. gals/min. 2.53 Imp. gals/min.

Condition

- Engine rated speed
2500 min⁻¹ (rpm)
- Rated pressure
11.5 to 12.5 MPa
118 to 127 kgf/cm²
1670 to 1810 psi
- Oil temperature
50 °C (122 °F)

9Y1210982HYS0007US0

(3) 3-Points Hitch Relief Valve

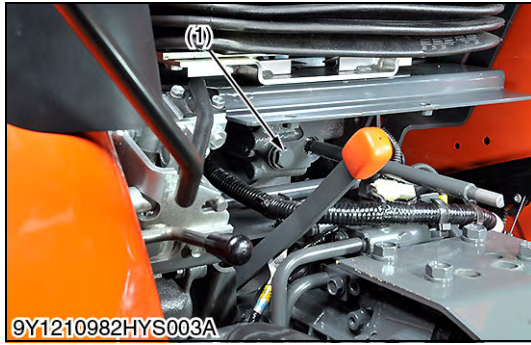

3-Points Hitch Relief Valve Setting Pressure

1. Remove the seat under cover.
2. Remove the plug (1) from the hydraulic cylinder block (5).
3. Install the adaptor **58** (See page G-50.). Then connect the cable and the pressure gauge to the adaptor.
4. Remove the feed back rod lock nut.
5. Start the engine and set the maximum speed.
6. Move the hydraulic control lever all way up to operate the relief valve and measure the pressure.
7. If the pressure is not factory specifications, adjust the relief valve setting pressure with the adjusting shims (4).
8. After checking the pressure, reinstall the feedback rod lock nut and the plug (1).

Relief valve setting pressure	Factory specification	Manual transmission model	15.5 to 16.5 MPa 158 to 168 kgf/cm ² 2248 to 2393 psi
		HST Model	16.5 to 16.9 MPa 169 to 172 kgf/cm ² 2400 to 2450 psi

Condition

- Engine rated speed
2500 min⁻¹ (rpm)
- Oil temperature
50 °C (122 °F)

(Reference)

[Manual Transmission Model (Without Front Loader Valve)]

- Thickness of shims (4)
0.1 mm (0.0039 in.)
0.2 mm (0.0079 in.)
0.4 mm (0.0160 in.)

[HST Model (With Front Loader Valve)]

- Thickness of shims (4)
0.10 mm (0.0039 in.)
0.20 mm (0.0079 in.)
0.40 mm (0.016 in.)
0.60 mm (0.024 in.)

- (1) Plug
- (2) Relief Valve
- (3) Plain Washer
- (4) Shim
- (5) Hydraulic Cylinder Block
- (6) Front Loader Valve

[A] Manual Transmission Model (Without Front Loader Valve)

[B] HST Model (With Front Loader Valve)

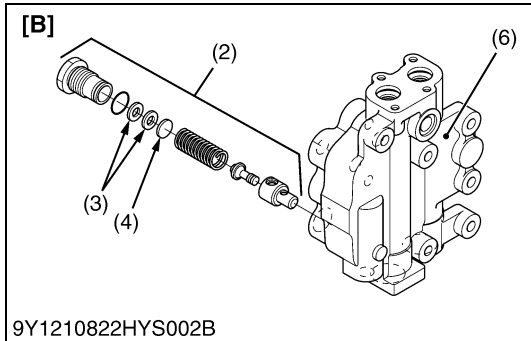
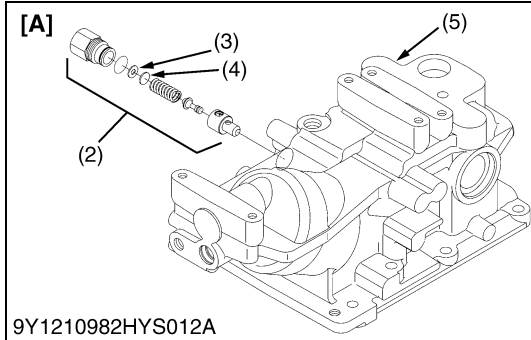

9Y1210982HYS0008US0

(4) Lift Arm

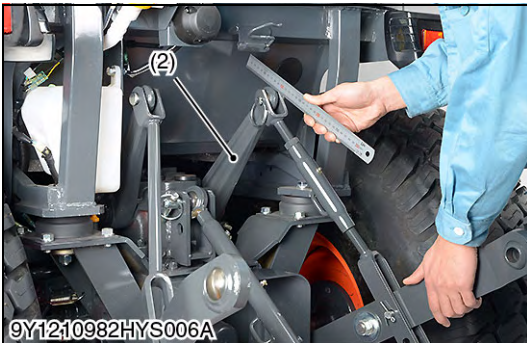
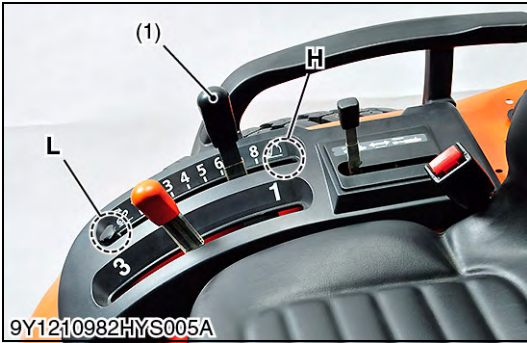

Lift Arm Free Play

1. Set the position control lever (1) to the lowest position.
2. Start the engine, and set at the idling speed.
3. Move the position control lever (1) to the uppermost position.
4. Move the lift arm (2) to the upper end by hand and measure the free play.
5. If the measurement is not within the factory specifications, adjust the free play by changing the position control feedback rod setting length.

Lift arm free play	Factory specification	5 to 15 mm 0.20 to 0.59 in.
--------------------	-----------------------	--------------------------------

- (1) Position Control Lever
- (2) Lift Arm

L: Lowest Position
H: Uppermost Position

9Y1210982HYS0009US0

[2] DISASSEMBLING AND ASSEMBLING

(1) Hydraulic Pump

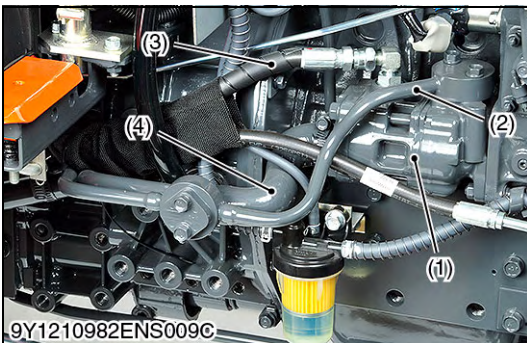

Removing Hydraulic Pump

1. Open the bonnet then remove the side cover (R.H.) and disconnect the battery grounding cord.
2. Disconnect the connector of the engine stop solenoid and accelerator rod.
3. Disconnect the power steering delivery hose.
4. Remove the engine stop solenoid.
5. Disconnect the suction hose.
6. Disconnect 3-points hitch delivery pipe and the hydraulic pump.

(When reassembling)

- Apply liquid gasket (Three Bond 1206D or equivalent) to engine stop solenoid.

- (1) Hydraulic Pump
- (2) 3-Point Hitch Delivery Pipe

- (3) Power Steering Delivery Hose
- (4) Suction Hose

9Y1210982HYS0010US0

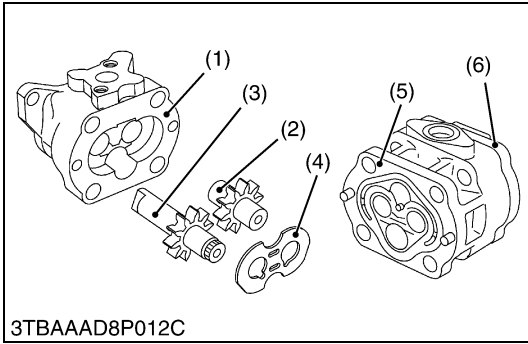

Hydraulic Pump Cover, Side Plate and Gear

1. Secure the hydraulic pump with a vise, and remove the hydraulic pump cover (6) with casing (5).
2. Remove the side plate (4).
3. Remove the drive gear (3) and driven gear (2) from the casing (1).

(When reassembling)

- Be careful not to damage the O-ring.
- Align the holes of the cover and casing (1).
- Install the side plate (4), noting its location and direction.
- Install the gears (2), (3), noting its direction.

Tightening torque	Hydraulic pump cover mounting screw	35 to 39 N·m 3.5 to 4.0 kgf·m 26 to 28 lbf·ft
-------------------	-------------------------------------	---

- | | |
|-----------------|--------------------------|
| (1) Casing | (4) Side Plate |
| (2) Driven Gear | (5) Casing |
| (3) Drive Gear | (6) Hydraulic Pump Cover |

9Y1210982HYS0011US0

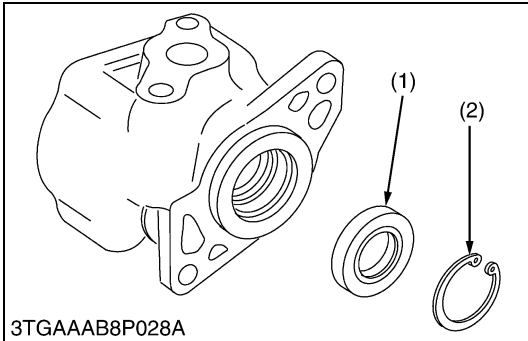

Oil Seal

1. Remove the internal snap ring (2), and remove the oil seal (1).

(When reassembling)

- If the oil seal is damaged, worn or scratched, replace it.

- | | |
|--------------|------------------------|
| (1) Oil Seal | (2) Internal Snap Ring |
|--------------|------------------------|

9Y1210982HYS0012US0

(2) 3-Point Hitch

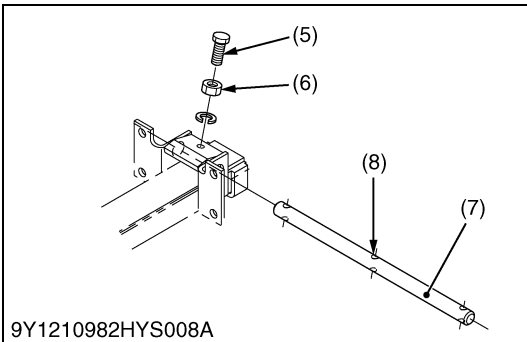
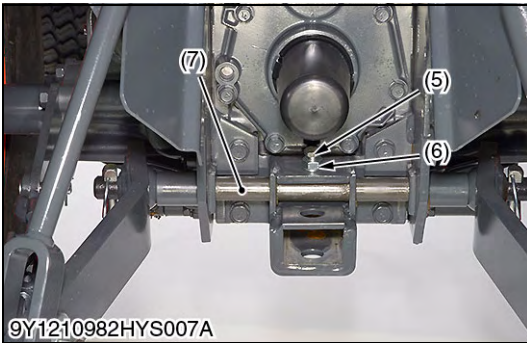
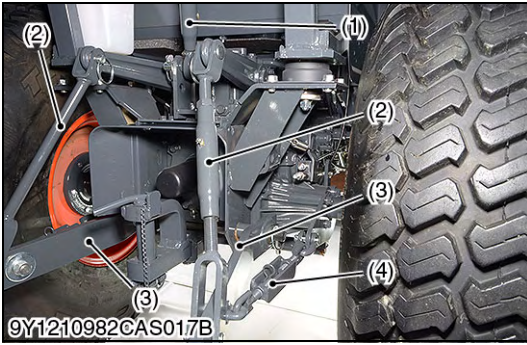

3-Point Hitch

1. Remove the top link.
2. Remove the lift rods.
3. Remove the check chains.
4. Remove the lower links.
5. Loosen the lock nut (6) and remove the set screw (5).
6. Remove the lower link pin (7).

(When reassembling)

■ IMPORTANT

- Be sure to align the set screw (5) and lower link pin hole (8), when installing the lower link pin (7).

Tightening torque	Set bolt of the lower link pin	15 to 20 N·m 1.6 to 2.0 kgf·m 11 to 14 lbf·ft
	Lock nut of the lower link pin	43 to 47 N·m 4.4 to 4.7 kgf·m 32 to 34 lbf·ft

- | | |
|-----------------|-------------------------|
| (1) Top Link | (5) Set Screw |
| (2) Lift Rod | (6) Lock Nut |
| (3) Lower link | (7) Lower Link Pin |
| (4) Check Chain | (8) Lower Link Pin Hole |

9Y1210982HYS0013US0

(3) Separating Hydraulic Cylinder From Tractor Body (ROPS Model)

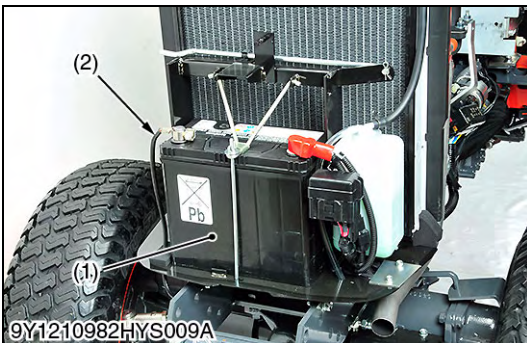

Battery Negative Cable

1. Disconnect the battery negative cable (2).

- | | |
|-------------|----------------------------|
| (1) Battery | (2) Battery Negative Cable |
|-------------|----------------------------|

9Y1210982HYS0014US0



Seat

1. Remove the seat (1).
2. Remove the seat support (2) and rear fender cover (3).

- | | |
|------------------|-----------------------|
| (1) Seat | (3) Rear Fender Cover |
| (2) Seat Support | |

9Y1210982HYS0015US0

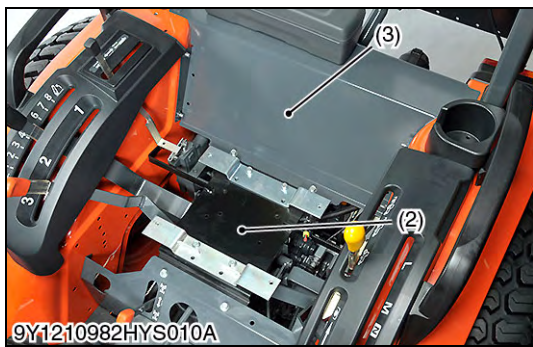

Separating Hydraulic Cylinder from Tractor Body

1. Disconnect lever linkage from hydraulic cylinder.
2. Disconnect the hydraulic delivery pipe from hydraulic cylinder.
3. Disconnect the wiring harness from switches and pull the wiring harness to the front side.
4. Remove the hydraulic cylinder.

9Y1210982HYS0016US0

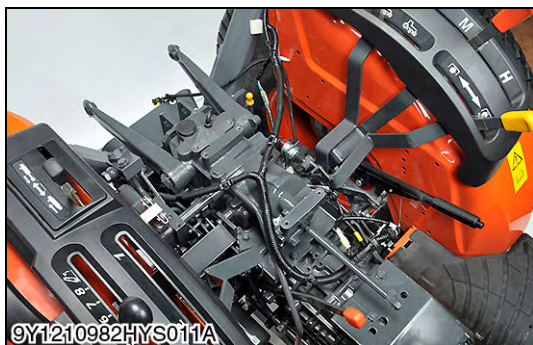

(4) Separating Hydraulic Cylinder From Tractor Body (CABIN Model)

Battery Negative Cable

1. Disconnect the battery negative cable (2).

- | | |
|-------------|----------------------------|
| (1) Battery | (2) Battery Negative Cable |
|-------------|----------------------------|

9Y1210982HYS0017US0

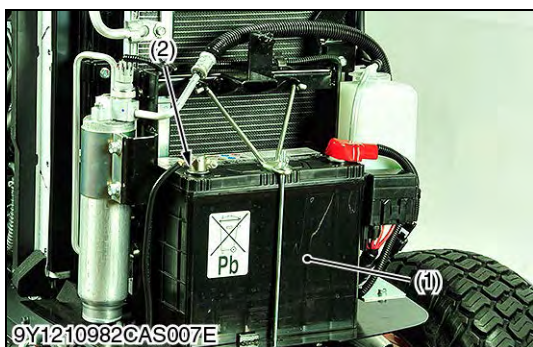

Draining Coolant

- See page 1-S23.

9Y1210982HYS0018US0

Separating Cabin from Tractor Body

- See page 10-S32.

9Y1210982HYS0019US0

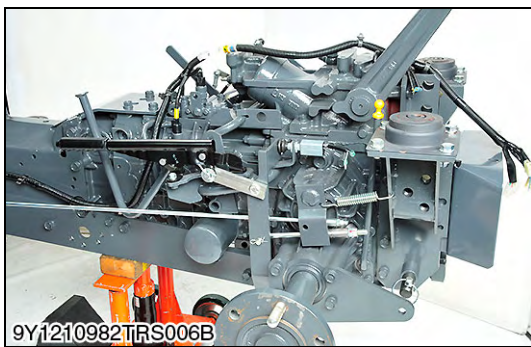

Separating Hydraulic Cylinder from Tractor Body

1. Disconnect the hydraulic delivery pipe from hydraulic cylinder.
2. Remove the hydraulic cylinder.

9Y1210982HYS0020US0

(5) 3-Points Hitch: Hydraulic Cylinder

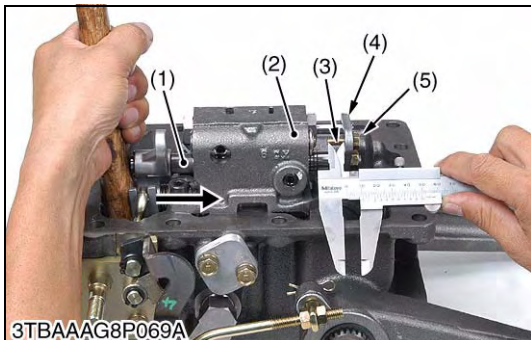

Checking the Length of the Adjusting Bolt

■ **NOTE**

- Before disassembling the control valve, check the length of the adjusting bolt.

1. Push the spool (1) into the control valve (2).
2. Check the length "L" of the adjusting bolt (3) as shown in the picture.

(Reference)

- Length L
Approx. 10.70 mm (0.421 in.)

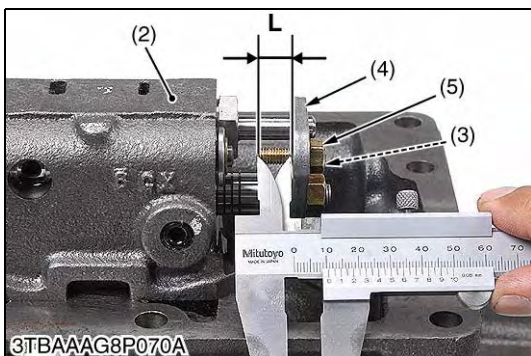

- (1) Spool
- (2) Control Valve
- (3) Adjusting Bolt
- (4) Connecting Plate
- (5) Nut

L: Length of the adjusting bolt

9Y1210982HYS0021US0

Control Valve

■ **NOTE**

- When the control valve is installed in the hydraulic cylinder, the hexagon wrench is not aligned straight to the hexagon bolt without pushing the spool as shown in the picture.

1. Push the spool (1) into the control valve (3).
2. Remove the hexagon bolts (2) with a hexagon wrench (4).

- | | |
|-------------------|--------------------|
| (1) Spool | (4) Hexagon Wrench |
| (2) Hexagon Bolt | (5) Adjusting Bolt |
| (3) Control Valve | |

9Y1210982HYS0022US0

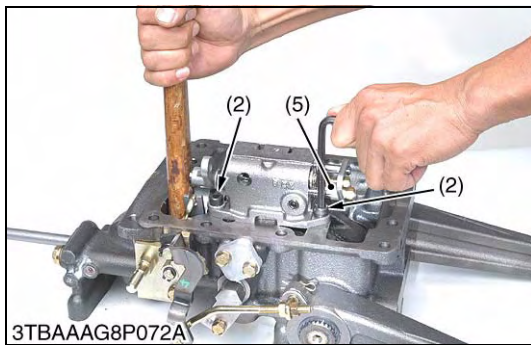
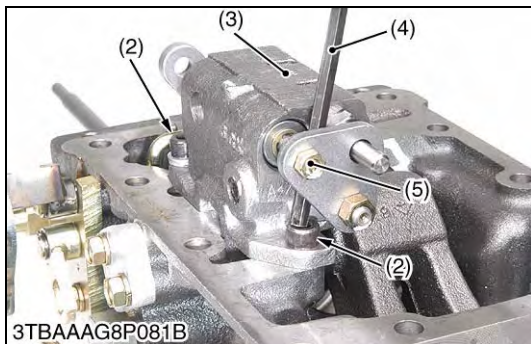
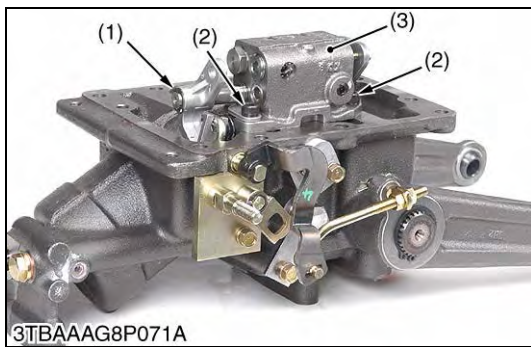

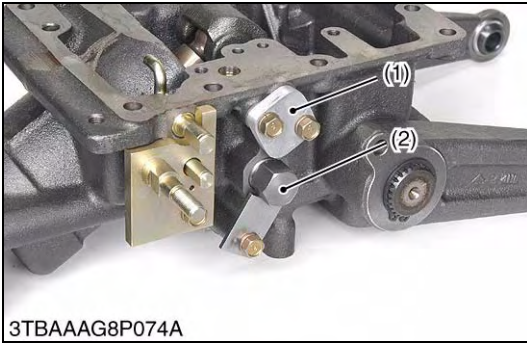

Relief Valve [Manual Transmission Model (Without Front Loader Control Valve)]

NOTE

- Refer to the page 8-M6 for the relief valve [HST model (with front loader control valve)]
- Remove the plug (2), and draw out the washer (7), the shim (6), the poppet (4) and the valve seat (3).

(When reassembling)

- Take care not to damage the O-ring.

Tightening torque	Relief valve plug	49.1 to 68.6 N·m 5.0 to 7.0 kgf·m 36.2 to 50.6 lbf·ft
-------------------	-------------------	---

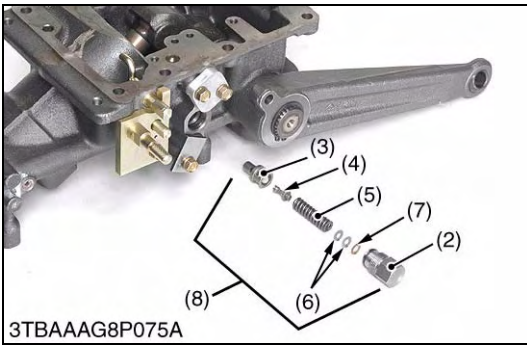

IMPORTANT

- After disassembling and reassembling the relief valve, be sure to adjust the relief valve setting pressure.

- | | |
|-------------------------|------------------|
| (1) Hydraulic Block Cap | (5) Spring |
| (2) Plug | (6) Shim |
| (3) Valve Seat | (7) Washer |
| (4) Poppet | (8) Relief Valve |

9Y1210982HYS0023US0

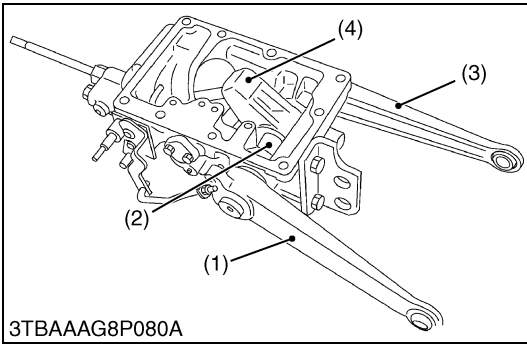

Lift Arm, Hydraulic Arm Shaft and Hydraulic Arm

- Remove the external snap ring, and remove the lift arm L.H. (2).
- Draw out the hydraulic arm shaft (3) and lift arm R.H. (4) as a unit.

(When reassembling)

- Align the alignment marks (5) of the hydraulic arm and hydraulic arm shaft.
- Align the alignment marks (6) of the lift arm L.H. and hydraulic arm shaft.
- Apply grease to the right and left bushings and O-rings.
- Take care not to damage the O-rings.

- | | |
|-------------------------|---------------------|
| (1) Lift Arm R.H. | (4) Hydraulic Arm |
| (2) Hydraulic Arm Shaft | (5) Alignment Marks |
| (3) Lift Arm L.H. | (6) Alignment Marks |

9Y1210982HYS0024US0

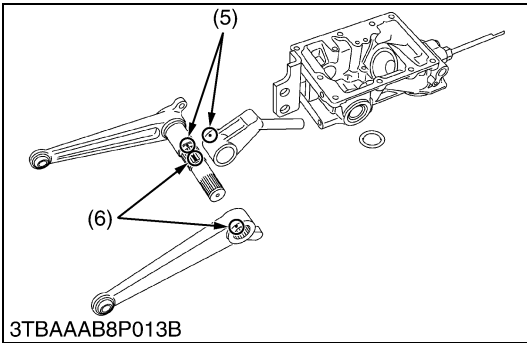

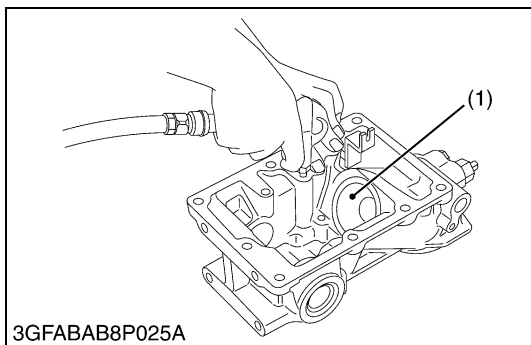

Hydraulic Piston

1. Inject the compressed air into the hydraulic cylinder, and remove the hydraulic piston (1).

(When reassembling)

- Take care not to damage the O-ring (3) and backup ring (2).
- Apply transmission fluid to the O-ring.
- Replace the O-ring if it is damaged, worn or scratched, which may cause oil leakage.

- | | |
|----------------------|------------|
| (1) Hydraulic Piston | (3) O-ring |
| (2) Backup Ring | |

9Y1210982HYS0025US0

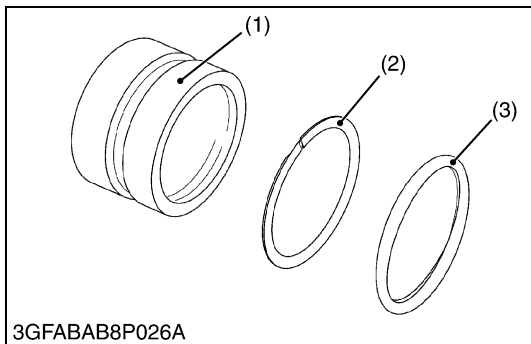

Hydraulic Adjust Shaft

1. Remove the internal cir-clip (1) and the hydraulic adjusting shaft (2).
2. Draw out the ball (5), the spring (6) and the collar (7).

(When reassembling)

- Take care not to damage the O-rings.

- | | |
|----------------------------|------------|
| (1) Internal Cir-clip | (5) Ball |
| (2) Hydraulic Adjust Shaft | (6) Spring |
| (3) Stopper | (7) Collar |
| (4) O-ring | |

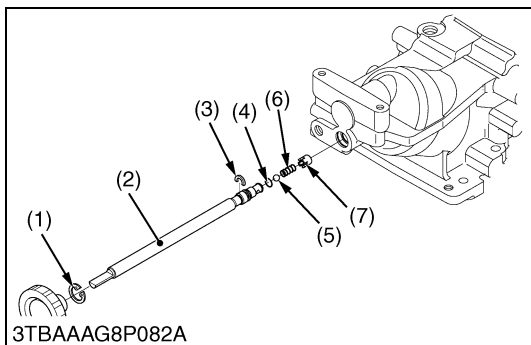

9Y1210982HYS0026US0

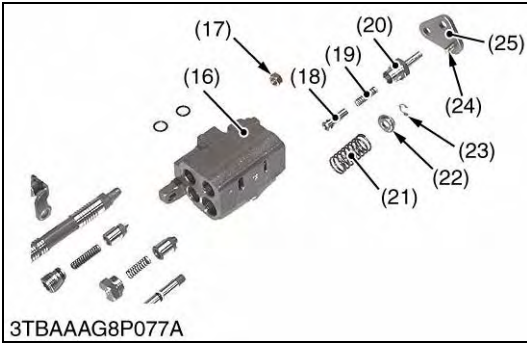
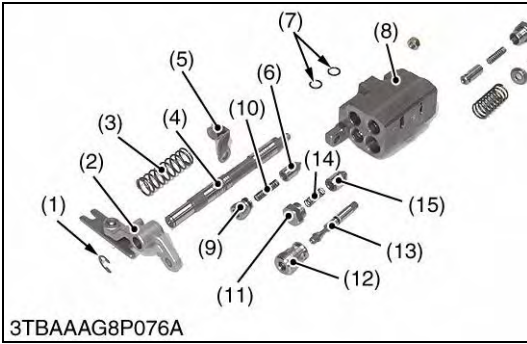

Disassembling Position Control Valve

1. After removing the control valve, disassemble the component parts as shown in the picture.

(When reassembling)

- Readjust the length "L" of the adjusting bolt.

(Reference)

- Length "L" : approximately 10.70 mm (0.4213 in.)

- | | |
|------------------------|-------------------------|
| (1) External Cir-clip | (15) Unload Poppet |
| (2) Lever | (16) Control Valve Body |
| (3) Spring | (17) Nut |
| (4) Spool | (18) Poppet |
| (5) Spring Holder | (19) Spring |
| (6) Poppet | (20) Plug |
| (7) O-ring | (21) Spring |
| (8) Control Valve Body | (22) Spring Holder |
| (9) Plug | (23) External Cir-clip |
| (10) Spring | (24) Adjusting Bolt |
| (11) Unload Plug | (25) Connecting Plate |
| (12) Plug | |
| (13) Poppet | |
| (14) Spring | |

L: Length of adjusting bolt

9Y1210982HYS0027US0

(6) Front Loader Control Valve Assembly (If Equipped)



Rear Wheel

1. Place the disassembling stand under the transmission case.
2. Remove the rear wheel (1).

Tightening torque	Rear wheel mounting nut and screw	B2050 B2350 B2650	108 to 126 N·m 11.1 to 12.8 kgf·m 79.7 to 92.9 lbf·ft
	Rear wheel mounting nut	B3150	167 to 191 N·m 17 to 19.5 kgf·m 123 to 141 lbf·ft
	Rear wheel mounting screw		196 to 225 N·m 20 to 23 kgf·m 145 to 166 lbf·ft

- (1) Rear Wheel

9Y1210982RAS0008US0

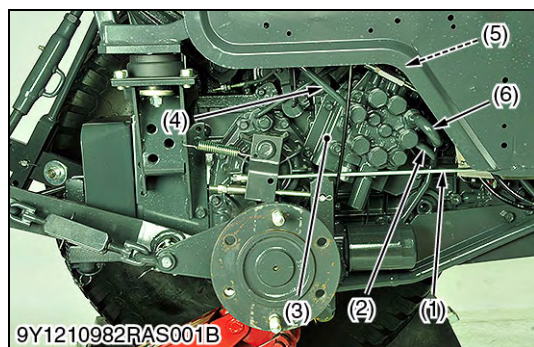

Front Loader Valve Assembly

1. Remove the brake rod (1).
2. Disconnect the 3-point hitch delivery pipe 1 (2), 3-point hitch delivery pipe 2 (4) and return hose (6).
3. Remove the loader valve assembly (3).
4. Remove the cable stay (5) with cables.

(When reassembling)

- Do not damage the O-rings of front loader valve pipes and delivery pipes.
- Apply liquid gasket (Three Bond 1206D or equivalent) to joint face of the rear axle case and differential gear case after eliminating the water and oil.

Tightening torque	Front loader valve pipe joint bolt	48 to 70 N·m 4.9 to 7.1 kgf·m 36 to 51 lbf·ft
	3-point hitch delivery pipe 1 joint bolt	48 to 70 N·m 4.9 to 7.1 kgf·m 36 to 51 lbf·ft
	3-point hitch delivery pipe 2 joint bolt (Front loader valve side)	48 to 70 N·m 4.9 to 7.1 kgf·m 36 to 51 lbf·ft
	3-point hitch delivery pipe 2 joint bolt (Hydraulic cylinder case side)	50 to 60 N·m 5.1 to 6.1 kgf·m 37 to 44 lbf·ft

- | | |
|-----------------------------------|-----------------------------------|
| (1) Brake Rod | (4) 3-Point Hitch Delivery Pipe 2 |
| (2) 3-Point Hitch Delivery Pipe 1 | (5) Cable Stay |
| (3) Loader Valve Assembly | (6) Return Hose |

9Y1210982HYS0028US0

Disassembling Front Loader Control Valve and Relief Valve [HST Model (With Front Loader Control Valve)]

■ **NOTE**

- Refer to the page 8-M7 for the relief valve [HST Model (With Front Loader Control Valve)]

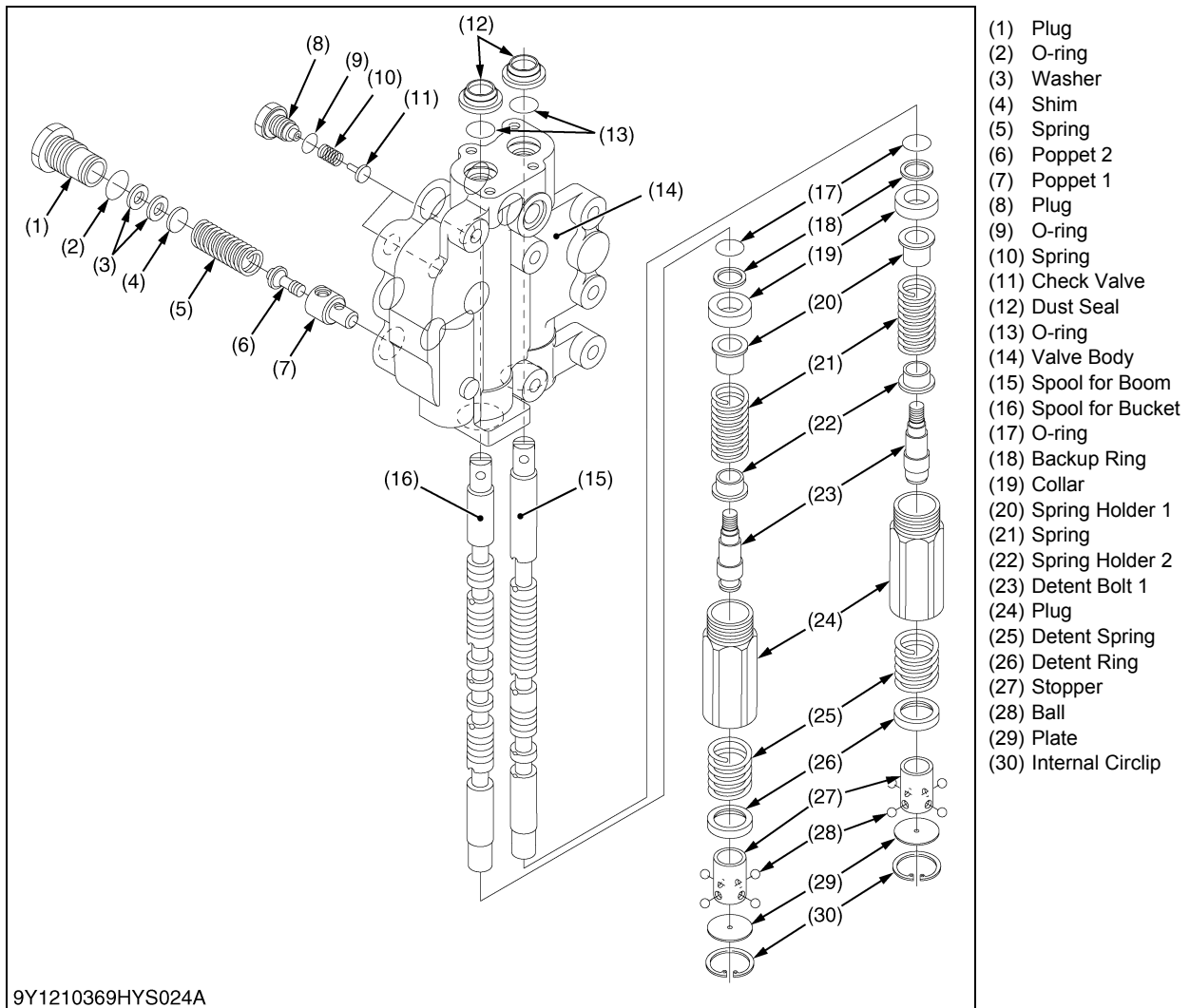

9Y1210369HYS024A

■ **Boom Control Section and Bucket Control Section**

1. Remove the plug (8), the spring (10) and load check valve (11).
2. Remove the plug (24) from valve body (14).
3. Remove the internal circlip (30), the stopper (27), detent spring (25), detent ring (26), and ball (28).
4. Draw out the spool (15), (16) with other component parts from valve body (14).

■ **Relief Valve**

1. Remove the plug (1), the spring (5) and poppet (6), (7).

9Y1210982HYS0029US0

(7) Remote Control Valve (If Equipped)

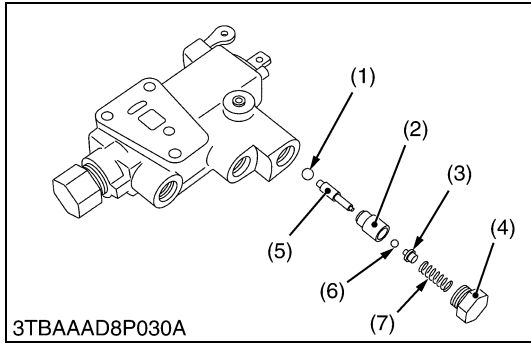

Poppet and Piston (Mechanical Check Valve)

1. Remove the plug 1 (4) and draw out the spring (7), ball guide (3), balls (1), (6), poppet (2) and piston (5).

(When reassembling)

- Take care not to damage the O-ring.

Tightening torque	Plug 1	29.4 to 49.0 N·m 3.0 to 5.0 kgf·m 21.7 to 36.2 lbf·ft
-------------------	--------	---

- | | |
|----------------|------------|
| (1) Ball | (5) Piston |
| (2) Poppet | (6) Ball |
| (3) Ball Guide | (7) Spring |
| (4) Plug 1 | |

9Y1210982HYS0030US0

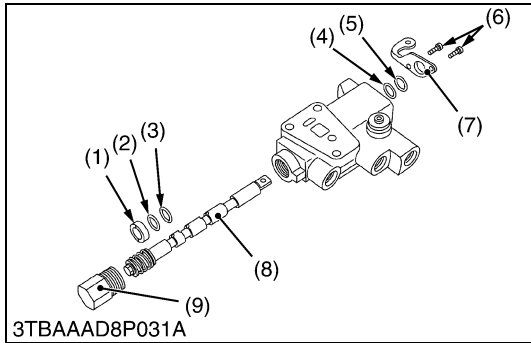

Spool

1. Remove the screws (6), and remove the bracket (7).
2. Remove the plug 2 (9), and draw out the spool (8).

(When reassembling)

- Take care not to damage the O-rings and backup rings.

Tightening torque	Bracket mounting screw	4.9 to 7.8 N·m 0.5 to 0.8 kgf·m 3.6 to 5.8 lbf·ft
	Plug 2	39.3 to 58.8 N·m 4.0 to 6.0 kgf·m 28.9 to 43.4 lbf·ft

- | | |
|-----------------|-------------|
| (1) Collar | (6) Screw |
| (2) Backup Ring | (7) Bracket |
| (3) O-ring | (8) Spool |
| (4) O-ring | (9) Plug 2 |
| (5) Backup Ring | |

9Y1210982HYS0031US0

[3] SERVICING

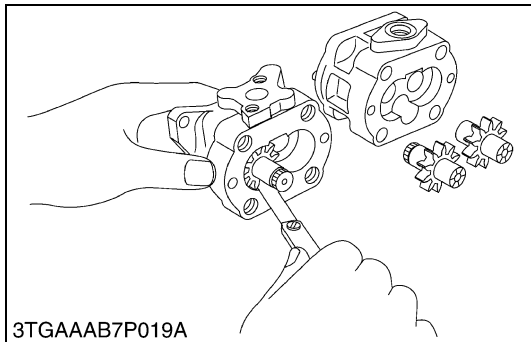

Clearance between Tip of Gear Tooth and Casing

1. Measure the clearance between gear and casing at several points with feeler gauge.
2. If the clearance exceeds the allowable limit, replace the assembly.

Clearance between tip of gear tooth and casing	Allowable limit	0.15 mm 0.0059 in.
--	-----------------	-----------------------

9Y1210982HYS0032US0

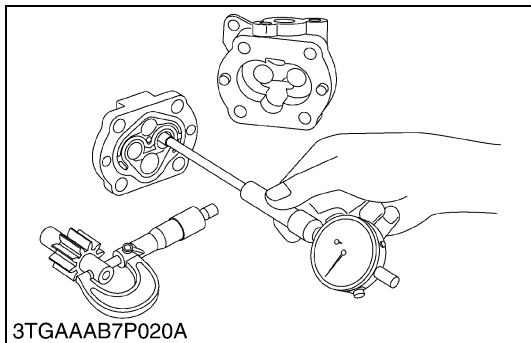

Clearance between Bushing and Shaft

1. Measure the shaft O.D. with an outside micrometer.
2. Measure the bushing I.D. with a cylinder gauge.
3. If the clearance exceeds the allowable limit, replace it.

Clearance between bushing and shaft	Factory specification	0.020 to 0.091 mm 0.0008 to 0.0036 in.
	Allowable limit	0.12 mm 0.0047 in.

Shaft O.D.	Factory specification	14.970 to 14.980 mm 0.5894 to 0.5898 in.
Bushing I.D.	Factory specification	15.000 to 15.061 mm 0.5906 to 0.5930 in.

9Y1210982HYS0033US0

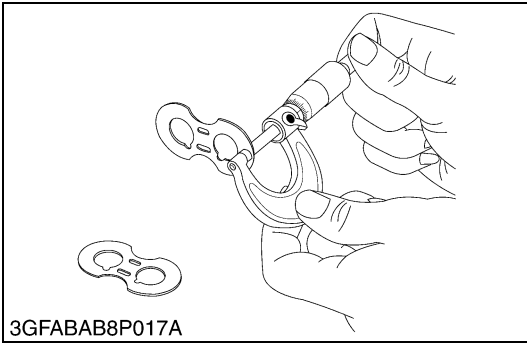

Side Plate Thickness

1. Measure the side plate thickness with an outside micrometer.
2. If the thickness is less than the allowable limit, replace it.

Side plate thickness	Factory specification	2.48 to 2.50 mm 0.0976 to 0.0984 in.
	Allowable limit	2.40 mm 0.0945 in.

9Y1210982HYS0034US0

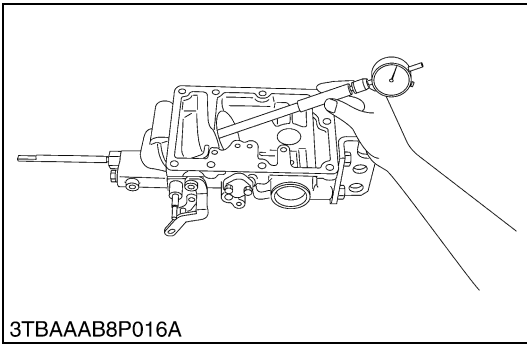

Hydraulic Cylinder Bore

1. Check the cylinder internal surface for scoring or damage.
2. Measure the cylinder I.D. with a cylinder gauge.
3. If the measurement exceeds the allowable limit, replace the hydraulic cylinder block.

Cylinder I.D.	Factory specification	75.05 to 75.10 mm 2.955 to 2.956 in.
	Allowable limit	75.15 mm 2.959 in.

9Y1210982HYS0035US0

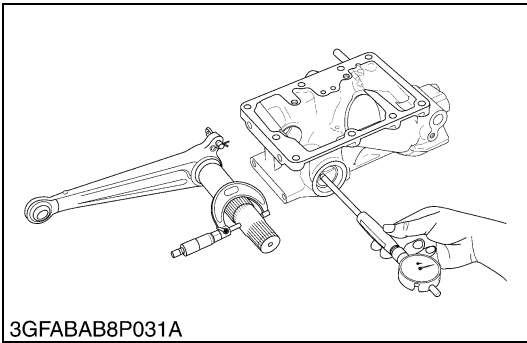

Clearance between Hydraulic Arm Shaft and Bushing

1. Measure the hydraulic arm shaft O.D. with an outside micrometer.
2. Measure the bushing I.D. with a cylinder gauge, and calculate the clearance.
3. If the clearance exceeds the allowable limit, replace the bushing.

Clearance between hydraulic arm shaft and bushing	Factory specification	0.020 to 0.110 mm 0.0008 to 0.0043 in.
	Allowable limit	0.30 mm 0.0118 in.

Hydraulic arm shaft O.D.	Factory specification	Right	37.925 to 37.950 mm 1.4931 to 1.4941 in.
		Left	34.925 to 34.950 mm 1.3750 to 1.3759 in.

Bushing I.D. (after press filed)	Factory specification	Right	37.970 to 38.035 mm 1.4949 to 1.4974 in.
		Left	34.970 to 35.035 mm 1.3768 to 1.3793 in.

9Y1210982HYS0036US0

9 ELECTRICAL SYSTEM

MECHANISM

CONTENTS

1. WIRING DIAGRAM.....	9-M1
[1] ROPS MODEL (EXCEPT FOR B3150).....	9-M1
[2] B3150 ROPS	9-M2
[3] CABIN MODEL.....	9-M3
2. ENGINE STARTING SYSTEM AND STOPPING SYSTEM.....	9-M4
[1] OPC SYSTEM CIRCUIT	9-M4
[2] CONTROLLER.....	9-M5
[3] SAFETY SWITCH	9-M10
(1) PTO Select Lever Switch (Only Model With Mid PTO).....	9-M11
(2) PTO Clutch Lever Switch	9-M12
(3) HST Pedal Switch (HST Model)	9-M12
(4) Shuttle Shift Lever Switch (Manual Transmission Model)	9-M13
(5) Seat Switch.....	9-M13
(6) Parking Brake Switch	9-M13
[4] STARTER.....	9-M14
[5] KEY STOP SOLENOID	9-M14
[6] GLOW PLUG.....	9-M15
3. CHARGING SYSTEM.....	9-M16
[1] ALTERNATOR	9-M17
[2] IC REGULATOR.....	9-M18
4. LIGHTING SYSTEM.....	9-M19
[1] HEAD LIGHT	9-M19
[2] TURN SIGNAL LIGHT	9-M21
[3] HAZARD LIGHT	9-M23
[4] BEACON	9-M25
[5] BRAKE LIGHT	9-M27
[6] WORK LIGHT (CABIN MODEL ONLY).....	9-M28
[7] TRAILER SOCKET.....	9-M29
5. INSTRUMENT PANEL	9-M30
[1] EASY CHECKER™.....	9-M30
[2] GAUGES AND OTHER INDICATORS.....	9-M31
[3] ERROR CODE DISPLAY (CABIN MODEL ONLY).....	9-M33
[4] SWITCHES AND SENSORS	9-M33

1. WIRING DIAGRAM

[1] ROPS MODEL (EXCEPT FOR B3150)

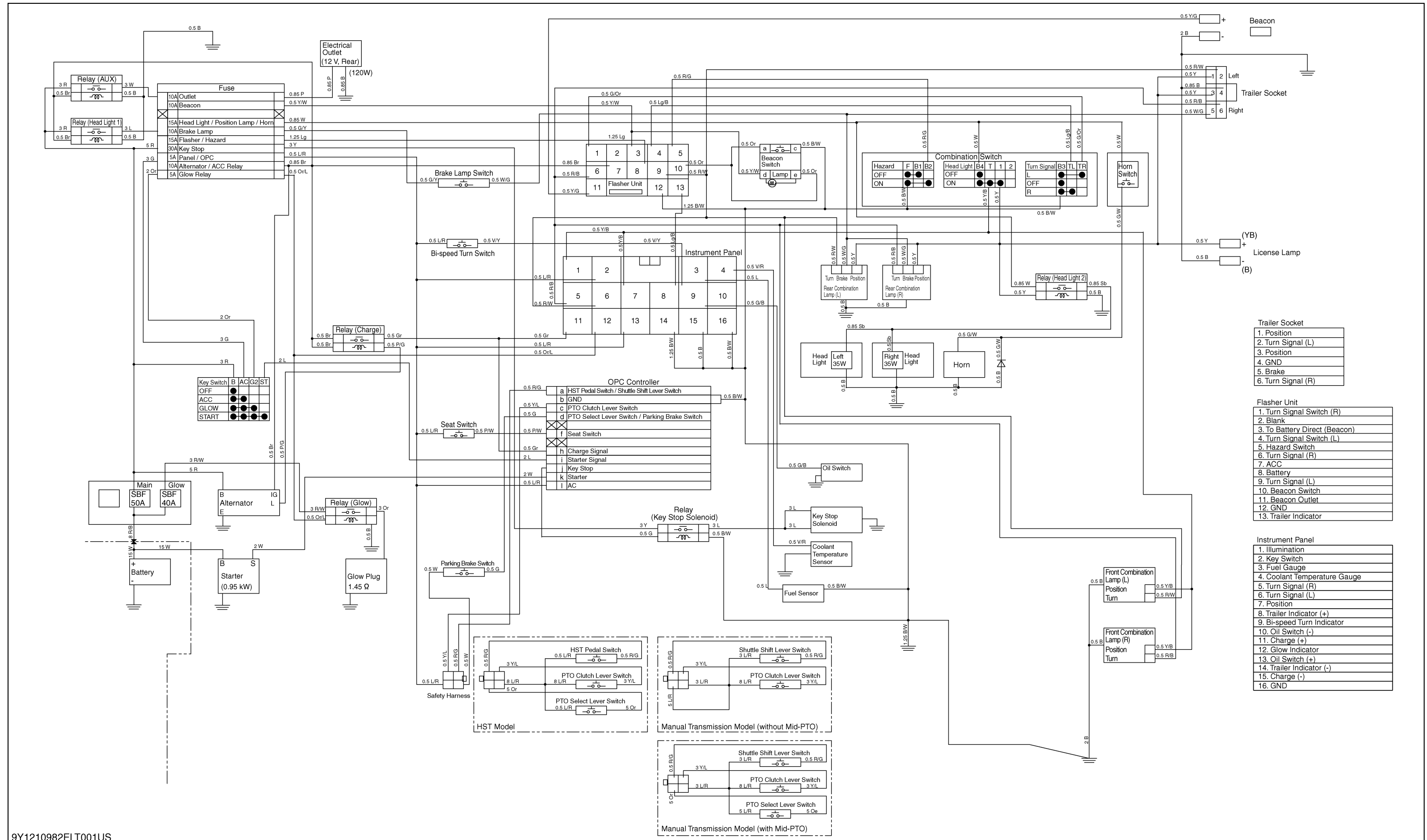

9Y1210982ELT001US

[2] B3150 ROPS

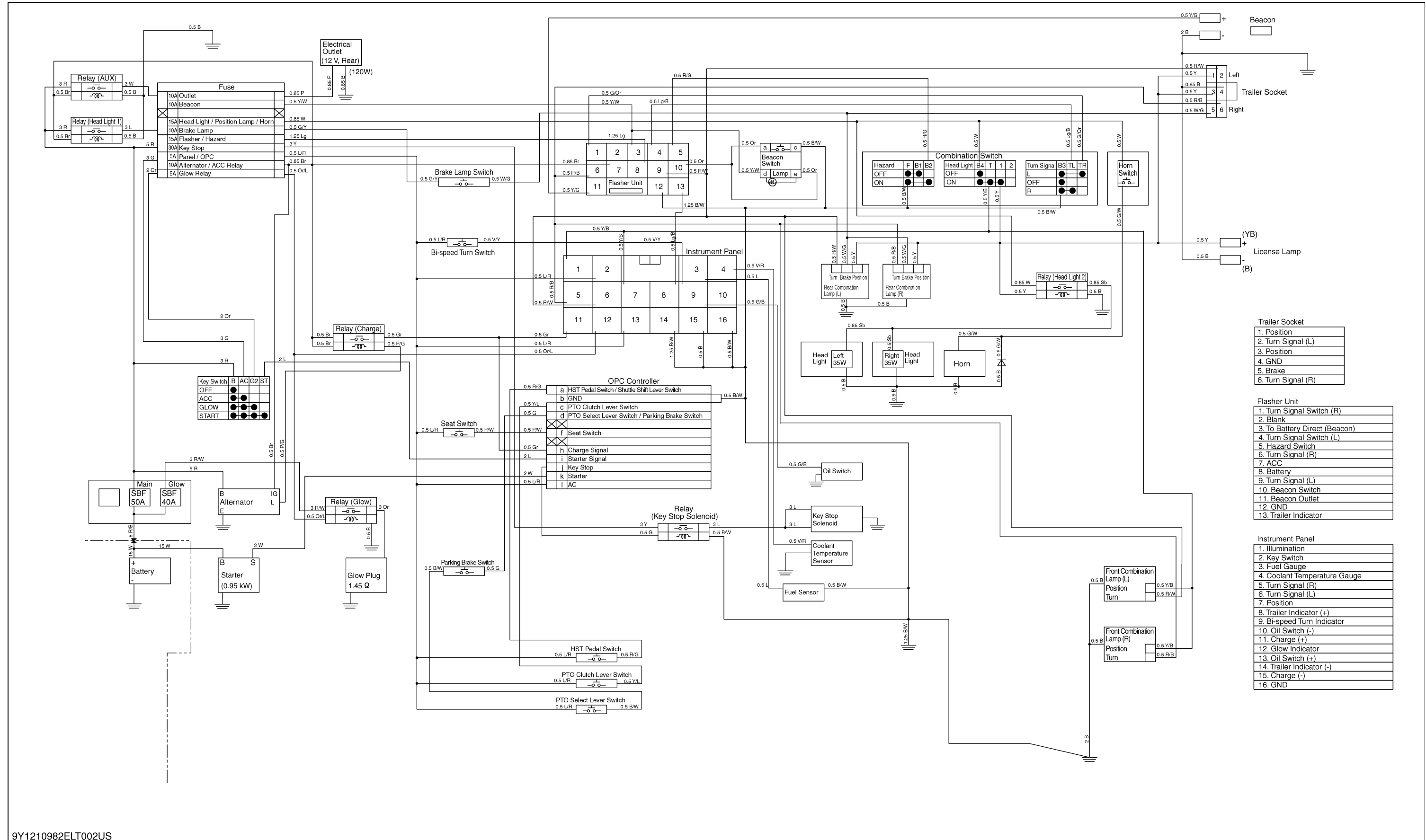

Trailer Socket

1.	Position
2.	Turn Signal (L)
3.	Position
4.	GND
5.	Brake
6.	Turn Signal (R)

Flasher Unit

1.	Turn Signal Switch (R)
2.	Blank
3.	To Battery Direct (Beacon)
4.	Turn Signal Switch (L)
5.	Hazard Switch
6.	Turn Signal (R)
7.	ACC
8.	Battery
9.	Turn Signal (L)
10.	Beacon Switch
11.	Beacon Outlet
12.	GND
13.	Trailer Indicator

Instrument Panel

1.	Illumination
2.	Key Switch
3.	Fuel Gauge
4.	Coolant Temperature Gauge
5.	Turn Signal (R)
6.	Turn Signal (L)
7.	Position
8.	Trailer Indicator (+)
9.	Bi-speed Turn Indicator
10.	Oil Switch (-)
11.	Charge (+)
12.	Glow Indicator
13.	Oil Switch (+)
14.	Trailer Indicator (-)
15.	Charge (-)
16.	GND

[3] CABIN MODEL

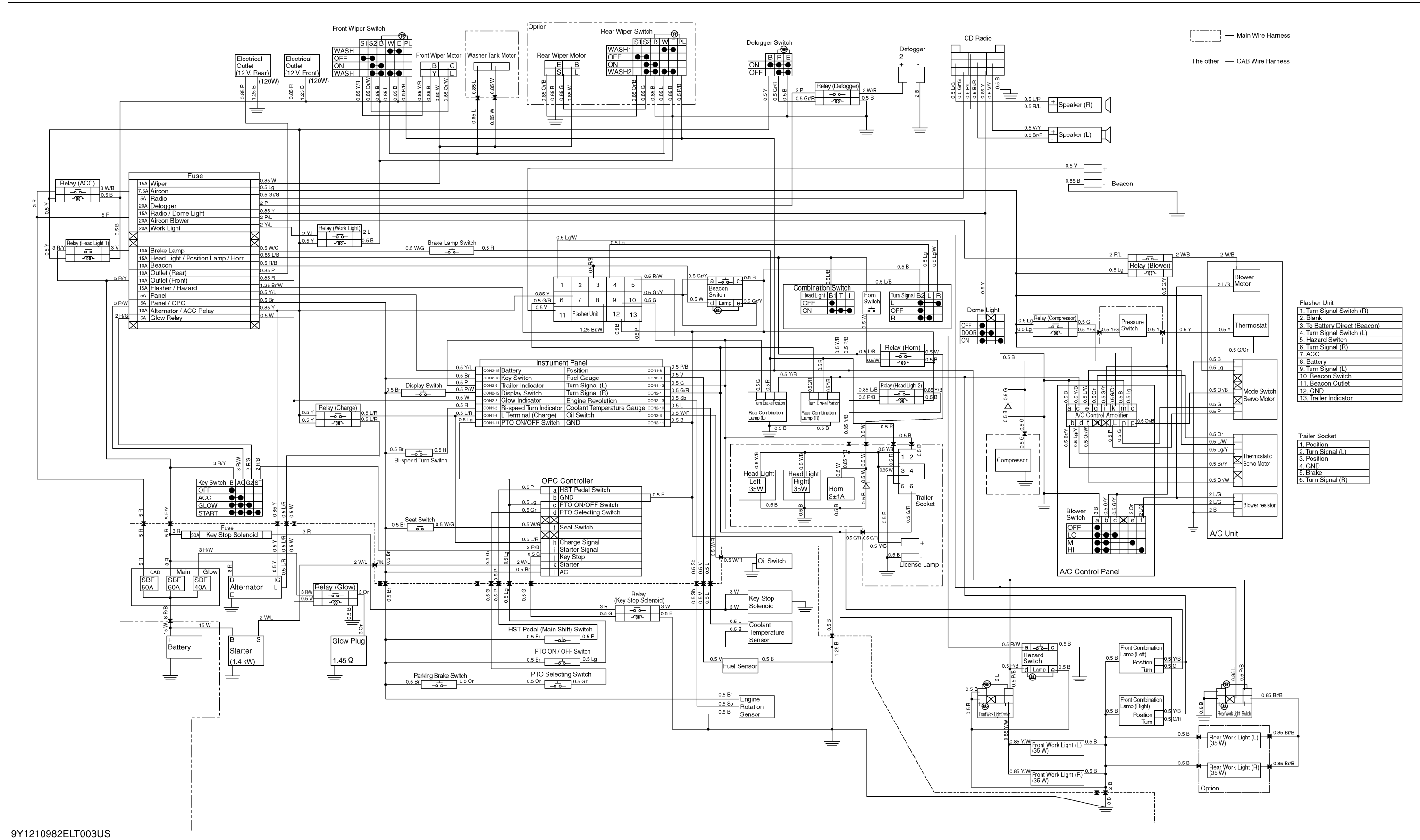

9Y1210982ELT003US

2. ENGINE STARTING SYSTEM AND STOPPING SYSTEM

Operator presence control (OPC) system which this series tractors are equipped with controls the engine starting and stopping according to the condition of safety switches (PTO clutch lever switch, PTO select lever switch, parking brake switch, seat switch, HST pedal switch and shuttle shift lever switch).

Engine starting is operated with starter motor after current flowing from controller to starter motor.

Engine stopping is operated with key stop solenoid after current flowing from controller through relay (key stop solenoid) to key stop solenoid.

9Y1210982ELM0004US0

[1] OPC SYSTEM CIRCUIT

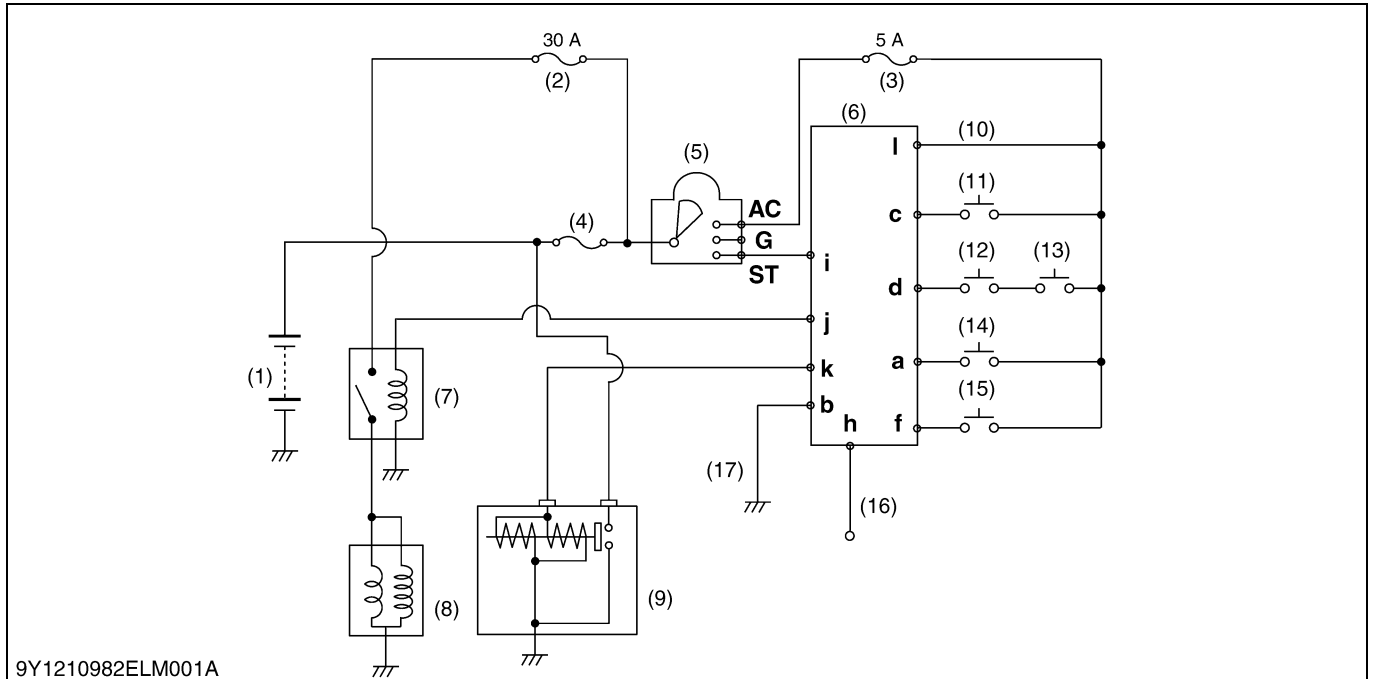

9Y1210982ELM001A

- | | | | |
|------------------------|-------------------------------|---------------------------------|-------------------------------------|
| (1) Battery | (7) Relay (Key Stop Solenoid) | (13) Parking Brake Switch | a to i : Controller Terminal |
| (2) Fuse (Key Stop) | (8) Key Stop Solenoid | (14) Shuttle Shift Lever Switch | AC: AC Terminal |
| (3) Fuse (Panel / OPC) | (9) Starter Motor | (15) Seat Switch | G: G Terminal |
| (4) Slow Blow Fuse | (10) AC Terminal Lead | (16) Relay (Charge) | ST: ST Terminal |
| ROPS Model (50 A) | (11) PTO Clutch Lever Switch | (17) Frame Earth | |
| CABIN Model (60 A) | (12) PTO Select Lever Switch | | |
| (5) Key Switch | (Only Model with Mid PTO) | | |
| (6) Controller | | | |

9Y1210982ELM0005US0

[2] CONTROLLER

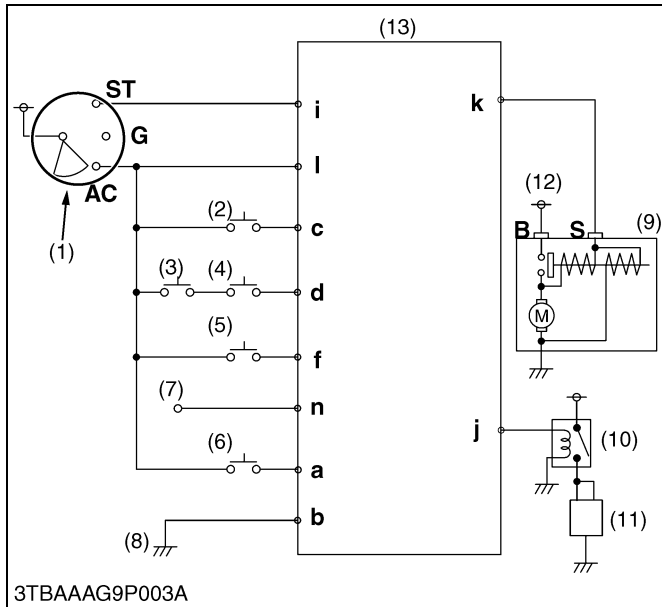

Operator Presence Control (OPC) System

This series tractor tractors are equipped with an "Operator Presence Control (OPC)" system to control engine starting and engine automatically stopping.

This OPC system mainly consists of controller and engine starting / stopping control switches such as PTO clutch lever switch, PTO select lever switch, parking brake switch, seat switch, HST pedal switch and shuttle shift lever switch.

Main parts regarding OPC system are laid out as shown in the electrical circuit.

- | | |
|--|--------------------------------|
| (1) Key Switch | (9) Starter Motor |
| (2) PTO Clutch Lever Switch | (10) Relay (Key Stop Solenoid) |
| (3) PTO Select Lever Switch | (11) Key Stop Solenoid |
| (4) Parking Brake Switch | (12) Battery |
| (5) Seat Switch | (13) OPC Controller |
| (6) HST Pedal Switch (HST Model) | |
| (7) Relay (Charge Shuttle Shift Lever Switch (Manual Transmission Model) | |
| (8) Frame Earth | |

- a to l: Controller Terminal**
ST: Key Switch ST Terminal
G: Key Switch G Terminal
AC: Key Switch AC Terminal
B: Starter Motor B Terminal
S: Starter Motor S Terminal

9Y1210982ELM0006US0

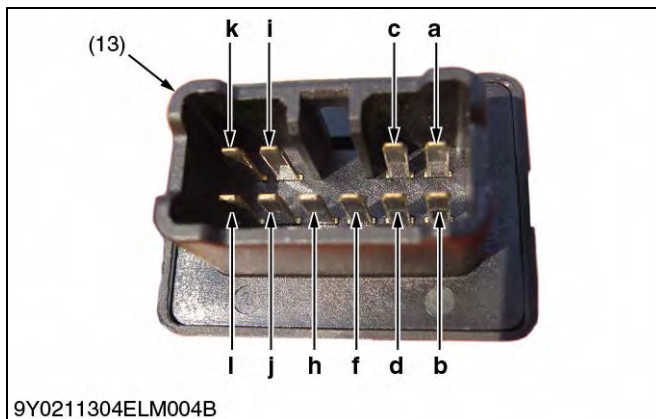
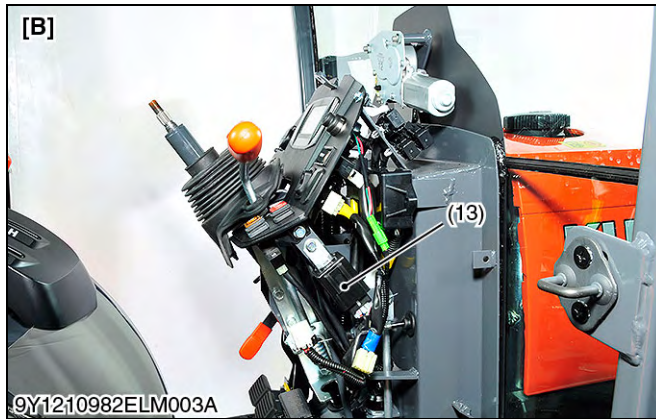
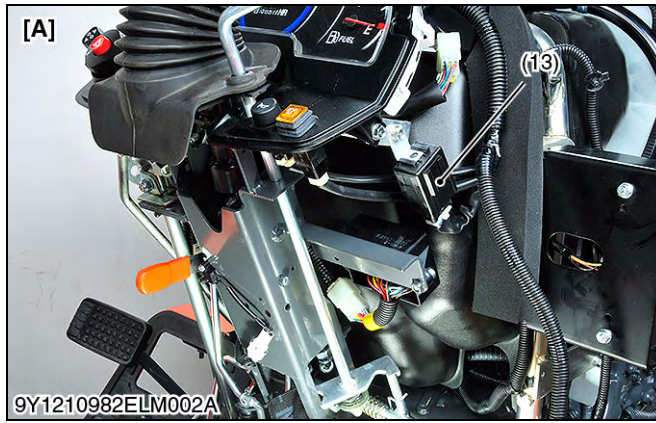

Controller

Controller is located inside the panel board.

Current from the key switch, safety switches and alternator L terminal flows to controller.

Controller receives current as data, processes the data, and sends out current computing results to starter motor, relay (key stop solenoid), and key stop solenoid.

OPC controller (13) controls engine starting and engine stopping.

Current flows from battery to controller.

Current from switches such as PTO clutch lever switch (2), PTO select lever switch (3), parking brake lever switch (4), seat switch (5), HST pedal switch (6) and shuttle shift lever switch (6), flows to the controller.

Current from relay (charge) (7) flows to the controller.

When starting the engine, the controller (13) supplies current to starter motor S terminal and relay (key stop solenoid) (10).

Controller (13) receives data, processes the data, and sends out the computing results.

Controller (13) receives data from safety switches, processes the data inside the controller itself, and sends out the computing results to starter motor (9) for engine starting, and relay (key stop solenoid) (10) for engine stopping.

- | | |
|---|------------------------------------|
| (1) Key Switch | (11) Key Stop Solenoid |
| (2) PTO Clutch Lever Switch | (12) Battery |
| (3) PTO Select Lever Switch | (13) OPC Controller |
| (4) Parking Brake Switch | |
| (5) Seat Switch | a to I: Controller Terminal |
| (6) HST Pedal Switch (HST Shuttle Shift Lever Switch (Manual Transmission Model)) | ST: Key Switch ST Terminal |
| (7) Relay (Charge) | G: Key Switch G Terminal |
| (8) Frame Earth | AC: Key Switch AC Terminal |
| (9) Starter Motor | B: Starter Motor B Terminal |
| (10) Relay (Key Stop Solenoid) | S: Starter Motor S Terminal |
| | →: Current Flow |
| | [A] ROPS Model |
| | [B] CABIN Model |

9Y1210982ELM0007US0

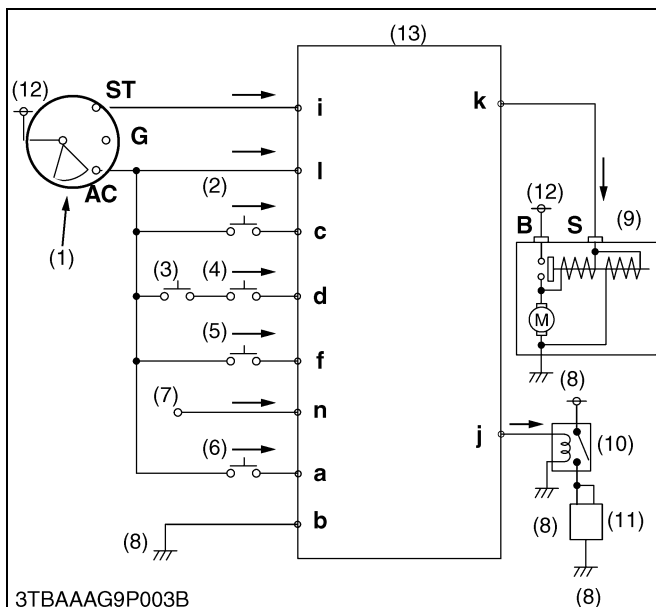

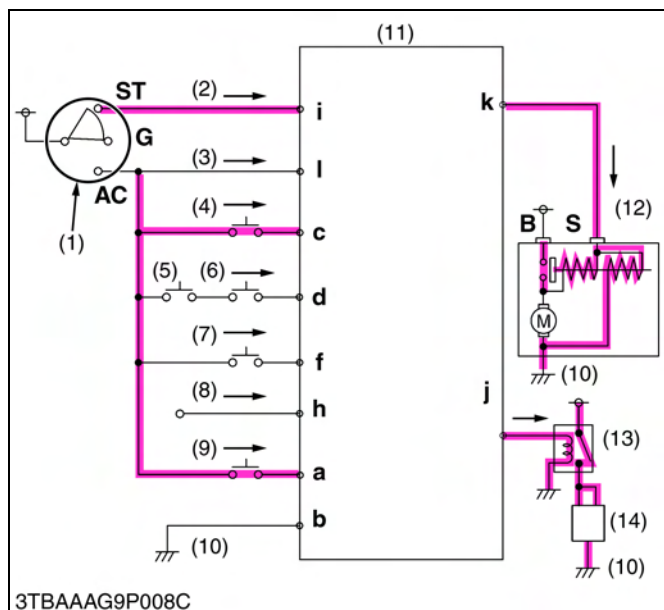

Engine Starting

When the following conditions become complete, output voltage (12 V) reaches coil terminal of the starter motor from controller k terminal, the engine can be started.

PTO Clutch Lever Switch (Disengaged : ON, Engaged : OFF)	ON
HST Pedal Switch (HST Model) Shuttle Shift Lever Switch (Manual Transmission Model) (Neutral : ON, Forward and Reverse : OFF)	ON

- (1) Key Switch
 - (2) **ST** Terminal Lead
 - (3) **AC** Terminal Lead
 - (4) PTO Clutch Lever Switch
 - (5) PTO Select Lever Switch
 - (6) Parking Brake Switch
 - (7) Seat Switch
 - (8) Relay (Charge)
 - (9) HST Pedal Switch (HST Model)
Shuttle Shift Lever Switch (Manual Transmission Model)
 - (10) Frame Earth
 - (11) Controller
 - (12) Starter Motor
 - (13) Relay (Key Stop Solenoid)
 - (14) Key Stop Solenoid
- ST, G, AC: Key Switch Terminals**
a to l: Controller Terminals
B: Starter Motor B Terminals
S: Starter Motor S Terminal
 →: **Current Flow**

9Y1210982ELM0008US0

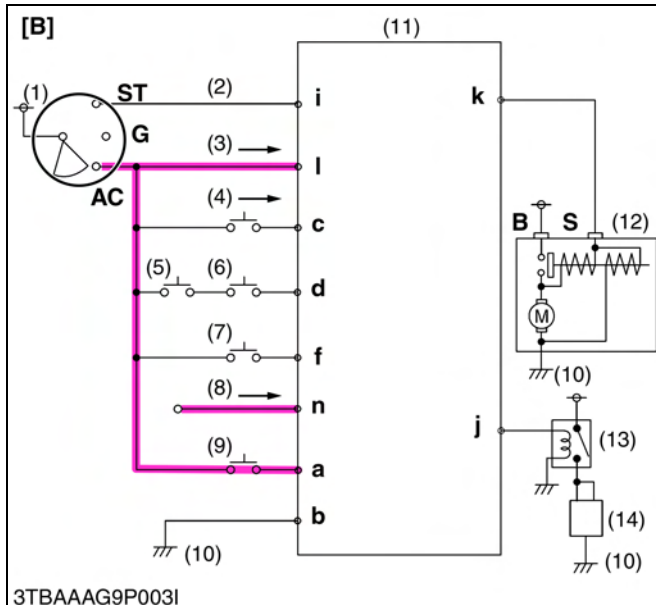
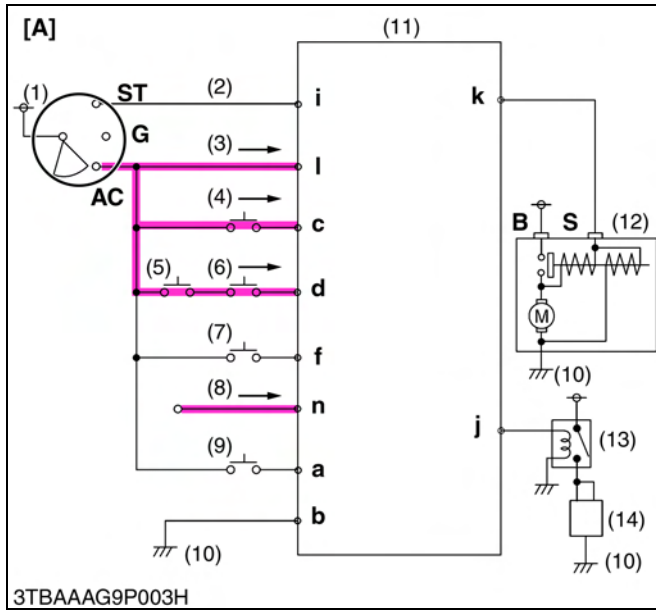

One Second Delay Engine Shutting Off

When one condition of the three patterns becomes complete, output voltage (12 V) to the relay (key stop solenoid) from controller j terminal will stop in one second delay.

Pattern 1

Seat Switch (Occupied : ON, Vacant : OFF)	OFF
HST Pedal Switch (HST Model) Shuttle Shift Lever Switch (Manual Transmission Model) (Neutral : ON, Forward and Reverse : OFF)	OFF

Pattern 2

Seat Switch (Occupied : ON, Vacant : OFF)	OFF
PTO Clutch Lever Switch (Disengaged : ON, Engaged : OFF)	OFF
Parking Brake Switch (Parking Lock : ON, Free : OFF)	OFF

Pattern 3

Seat Switch (Occupied : ON, Vacant : OFF)	OFF
PTO Clutch Lever Switch (Disengaged : ON, Engaged : OFF)	OFF
PTO Select Lever Switch (Rear PTO : ON, Rear/Mid or Mid PTO : OFF)	OFF

- (1) Key Switch
 - (2) **ST** Terminal Lead
 - (3) **AC** Terminal Lead
 - (4) PTO Clutch Lever Switch
 - (5) PTO Select Lever Switch
 - (6) Parking Brake Switch
 - (7) Seat Switch
 - (8) Relay (Charge)
 - (9) HST Pedal Switch (HST Model)
Shuttle Shift Lever Switch (Manual Transmission Model)
 - (10) Frame Earth
 - (11) Controller
 - (12) Starter Motor
 - (13) Relay (Key Stop Solenoid)
 - (14) Key Stop Solenoid
- [A] Pattern 1**
[B] Pattern 2 and 3
ST, G, AC: Key Switch Terminals
B: Starter Motor B Terminal
S: Starter Motor S Terminal
a to l: Controller Terminals
→: Current Flow

9Y1210982ELM0009US0

Safety Switch Position and Engine Condition**Model With Mid PTO**

	HST Pedal Switch or Shuttle Shift Lever Switch	PTO Select Lever Switch	PTO Clutch Lever Switch	Parking Brake Switch	Seat Switch	Engine Start	Engine Stop
	Neutral (ON)	Only Rear PTO (ON)	Disengaged (ON)	Lock (ON)	Sit (ON)	Cannot Start	Engine Stop (ON)
	Forward or Reverse (OFF)	Mid PTO Engaged (OFF)	Engaged (OFF)	Unlock (OFF)	Stand (OFF)	Start	Engine does not Stop (OFF)
1	ON	ON	ON	ON	ON	Start	OFF
2	ON	OFF	ON	ON	ON	Start	OFF
3	ON	ON	ON	ON	OFF	Start	OFF
4	ON	OFF	ON	ON	OFF	Start	OFF
5	ON	ON	ON	OFF	ON	Start	OFF
6	ON	OFF	ON	OFF	ON	Start	OFF
7	ON	ON	ON	OFF	OFF	Start	OFF
8	ON	OFF	ON	OFF	OFF	Start	OFF
9	ON	ON	OFF	ON	ON	Cannot Start	OFF
10	ON	OFF	OFF	ON	ON	Cannot Start	OFF
11	ON	ON	OFF	ON	OFF	Cannot Start	OFF
12	ON	OFF	OFF	ON	OFF	Cannot Start	ON
13	ON	ON	OFF	OFF	ON	Cannot Start	OFF
14	ON	OFF	OFF	OFF	ON	Cannot Start	OFF
15	ON	ON	OFF	OFF	OFF	Cannot Start	ON
16	ON	OFF	OFF	OFF	OFF	Cannot Start	ON
17	OFF	ON	ON	ON	ON	Cannot Start	OFF
18	OFF	OFF	ON	ON	ON	Cannot Start	OFF
19	OFF	ON	ON	ON	OFF	Cannot Start	ON
20	OFF	OFF	ON	ON	OFF	Cannot Start	ON
21	OFF	ON	ON	OFF	ON	Cannot Start	OFF
22	OFF	OFF	ON	OFF	ON	Cannot Start	OFF
23	OFF	ON	ON	OFF	OFF	Cannot Start	ON
24	OFF	OFF	ON	OFF	OFF	Cannot Start	ON
25	OFF	ON	OFF	ON	ON	Cannot Start	OFF
26	OFF	OFF	OFF	ON	ON	Cannot Start	OFF
27	OFF	ON	OFF	ON	OFF	Cannot Start	ON
28	OFF	OFF	OFF	ON	OFF	Cannot Start	ON
29	OFF	ON	OFF	OFF	ON	Cannot Start	OFF
30	OFF	OFF	OFF	OFF	ON	Cannot Start	OFF
31	OFF	ON	OFF	OFF	OFF	Cannot Start	ON
32	OFF	OFF	OFF	OFF	OFF	Cannot Start	ON

9Y1210982ELM0010US0

Model Without Mid PTO

	HST Pedal Switch or Shuttle Shift Lever Switch	PTO Clutch Lever Switch	Parking Brake Switch	Seat Switch	Engine Start	Engine Stop
	Neutral (ON)	Disengaged (ON)	Lock (ON)	Sit (ON)	Cannot Start	Engine Stop (ON)
	Forward or Reverse (OFF)	Engaged (OFF)	Unlock (OFF)	Stand (OFF)	Start	Engine does not Stop (OFF)
1	ON	ON	ON	ON	Start	OFF
2	ON	ON	ON	OFF	Start	OFF
3	ON	ON	OFF	ON	Start	OFF
4	ON	ON	OFF	OFF	Start	OFF
5	ON	OFF	ON	ON	Cannot Start	OFF
6	ON	OFF	ON	OFF	Cannot Start	OFF
7	ON	OFF	OFF	ON	Cannot Start	OFF
8	ON	OFF	OFF	OFF	Cannot Start	ON
9	OFF	ON	ON	ON	Cannot Start	OFF
10	OFF	ON	ON	OFF	Cannot Start	ON
11	OFF	ON	OFF	ON	Cannot Start	OFF
12	OFF	ON	OFF	OFF	Cannot Start	ON
13	OFF	OFF	ON	ON	Cannot Start	OFF
14	OFF	OFF	ON	OFF	Cannot Start	ON
15	OFF	OFF	OFF	ON	Cannot Start	OFF
16	OFF	OFF	OFF	OFF	Cannot Start	ON

9Y1210982ELM0011US0

[3] SAFETY SWITCH

■ **Type of Safety Switch**

There are two types of safety switches, normally closed type and normally open type.

Normally closed type switch is electrically closed in normal condition.

Normally open type switch is electrically opened in normal condition.

Safety switches adopted in this series tractors operate as sensor detecting the position of HST pedal, PTO select lever, PTO clutch lever, seat and parking brake to OPC controller.

Normally Closed Type	Normally Open Type
PTO Select Lever Switch (Only Model With Mid PTO)	HST Pedal Switch (HST Model)
	PTO Clutch Lever Switch (Manual Transmission Model)
PTO Clutch Lever Switch (HST Model)	Seat Switch
Shuttle Shift Lever Switch (Manual Transmission Model)	Parking Brake Switch

9Y1210982ELM0012US0

(1) PTO Select Lever Switch (Only Model With Mid PTO)

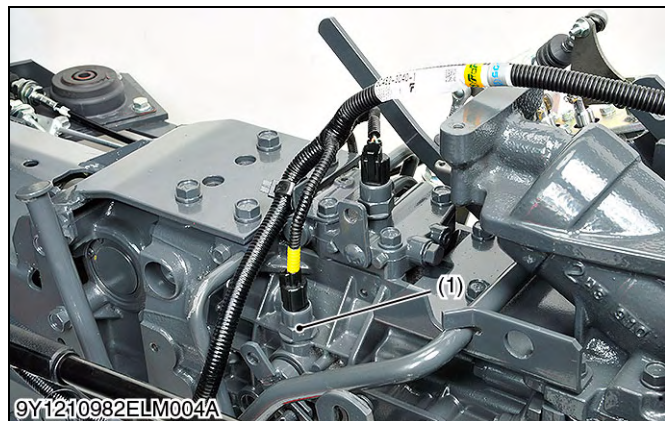

PTO Select Lever Switch (Only Model With Mid PTO)

This switch locates at transmission case.

This switch is a push type.

This switch detects the position of the PTO select lever.

When the PTO select lever is at **"REAR PTO"** position, this switch is turned to **"ON"**.

When the PTO select lever is at **"Rear/Mid, Mid PTO"** position, this switch is turned to **"OFF"**.

- | | |
|-----------------------------|---------------------------------------|
| (1) PTO Select Lever Switch | A: Rear PTO Position |
| (2) PTO Select Lever | B: Rear PTO / Mid PTO Position |
| | C: Mid PTO Position |

9Y1210982ELM0013US0

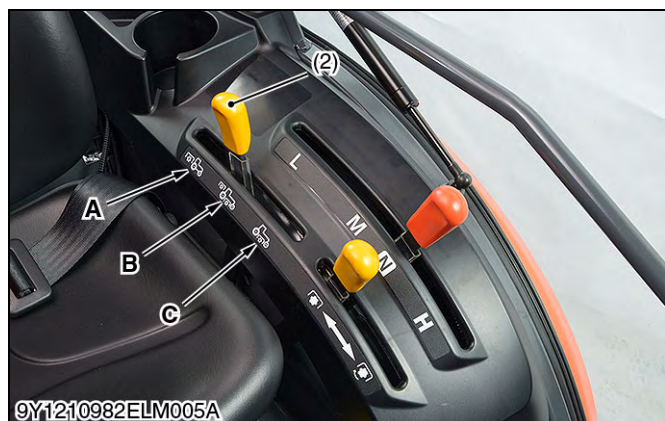

(2) PTO Clutch Lever Switch

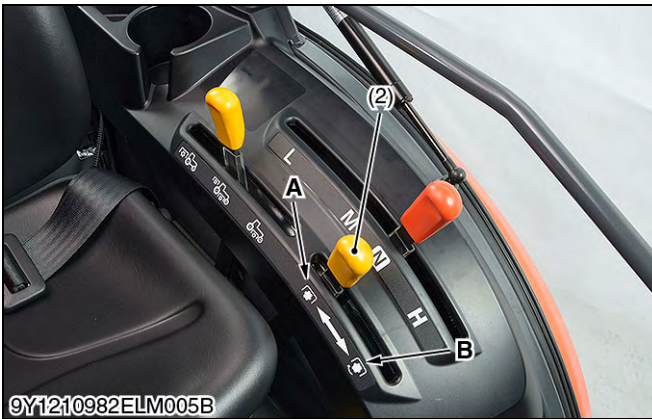
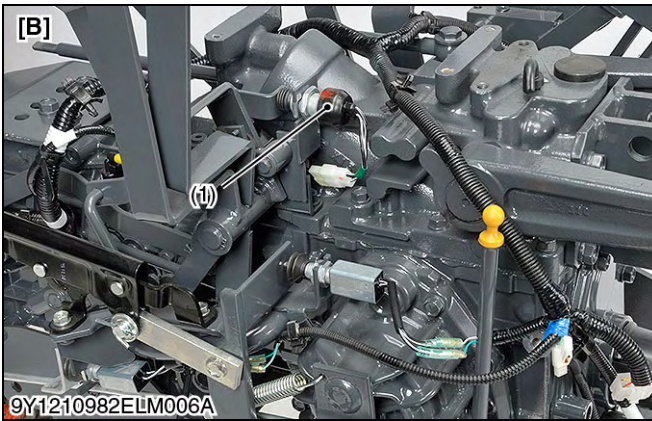
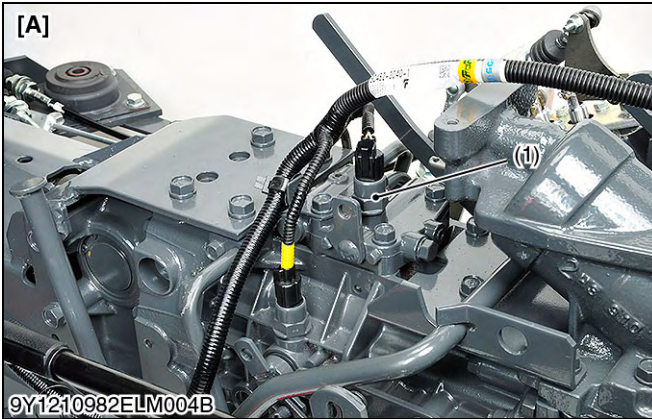

(3) HST Pedal Switch (HST Model)

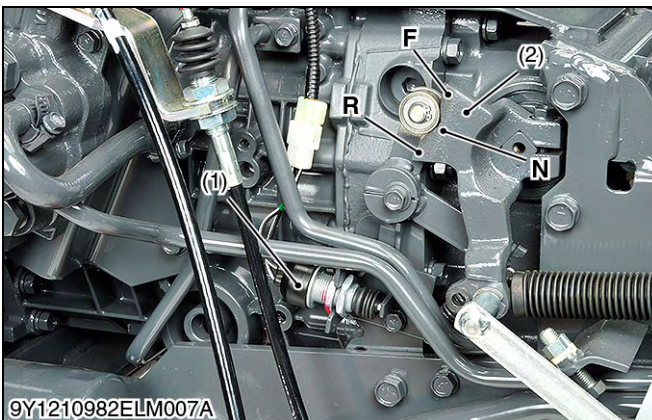

PTO Clutch Lever Switch

This switch is a push type.

This switch detects the PTO clutch engagement.

When the PTO clutch lever is set to **"DISENGAGED"** position, this switch is turned to **"ON"**.

When the PTO clutch lever is set to **"ENGAGED"** position, this switch is turned to **"OFF"**.

- | | |
|-----------------------------|--------------------------------------|
| (1) PTO Clutch Lever Switch | A: "DISENGAGED" Position |
| (2) PTO Clutch Lever | B: "ENGAGED" Position |
| | [A] HST Model |
| | [B] Manual Transmission Model |

9Y1210982ELM0014US0

HST Pedal Switch

This switch located at the neutral switch stay.

This switch is a push type.

This switch detects the position of the HST pedal.

When HST pedal is at **"NEUTRAL"** position, this switch is turned to **"ON"**.

When HST pedal is at **"FORWARD"** or **"REVERSE"** position, this switch is turned to **"OFF"**.

- | | |
|----------------------|-------------------|
| (1) HST Pedal Switch | F: FORWARD |
| (2) Neutral Holder | N: NEUTRAL |
| | R: REVERSE |

9Y1210982ELM0015US0

(4) Shuttle Shift Lever Switch (Manual Transmission Model)

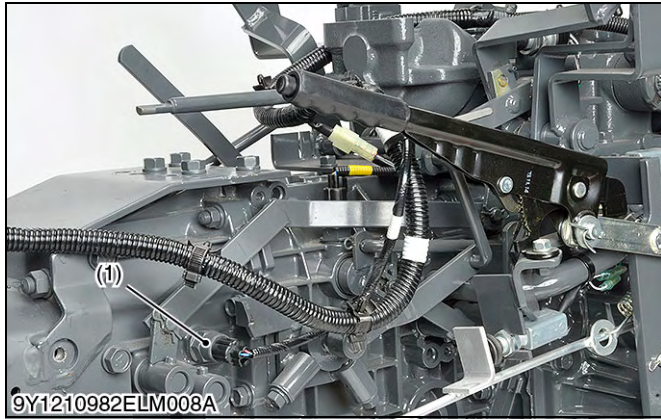

Shuttle Shift Lever Switch (Manual Transmission Model)

This switch is a push type.

This switch detects the position of the shuttle shift lever.

When the shuttle shift lever is at **"NEUTRAL"** position, this switch is turned to **"ON"**.

When the shuttle shift lever is at **"FORWARD"** or **"REVERSE"** position, this switch is turned to **"OFF"**.

- (1) Shuttle Shift Lever Switch (2) Shuttle Shift Lever

9Y1210982ELM0016US0

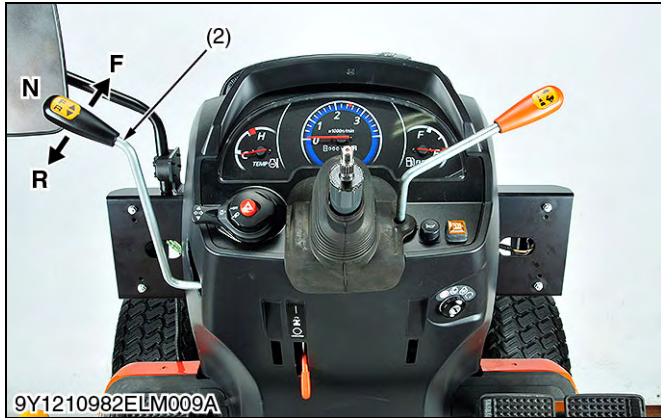

(5) Seat Switch

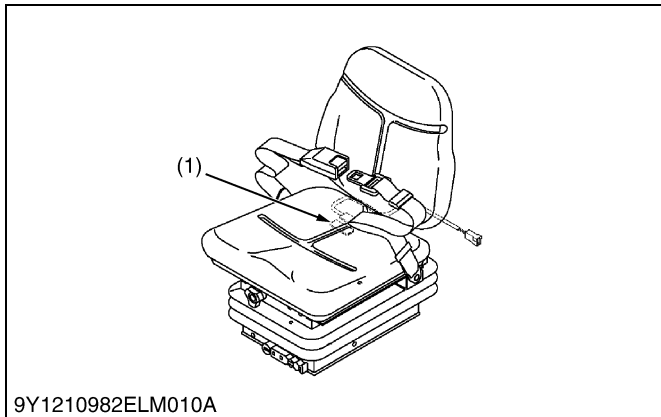

Seat Switch

This switch locates under the seat.

This switch is a push type.

This switch detects the operator's sitting on the seat or not.

When the operator sits on the seat, this switch is turned to **"ON"**.

When the operator stand up from the seat, this switch is turned to **"OFF"**.

- (1) Seat Switch

9Y1210982ELM0017US0

(6) Parking Brake Switch

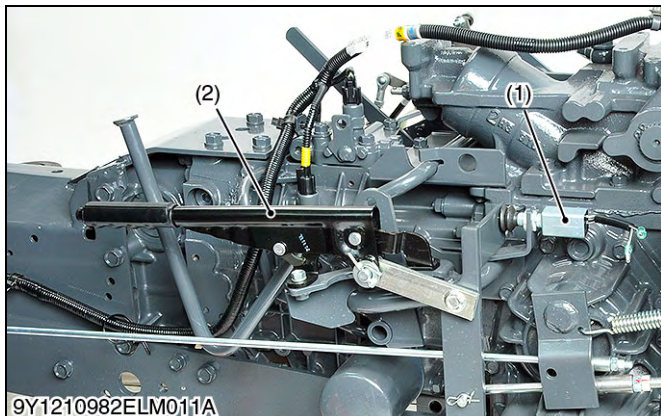

Parking Brake Switch

This switch is a push type.

This switch detects the parking brake is locked or not.

When the parking brake is locked, this switch is turned to **"ON"**.

When the parking brake is not locked, this switch is turned to **"OFF"**.

- (1) Parking Brake Switch (2) Parking Brake Lever

9Y1210982ELM0018US0

[4] STARTER

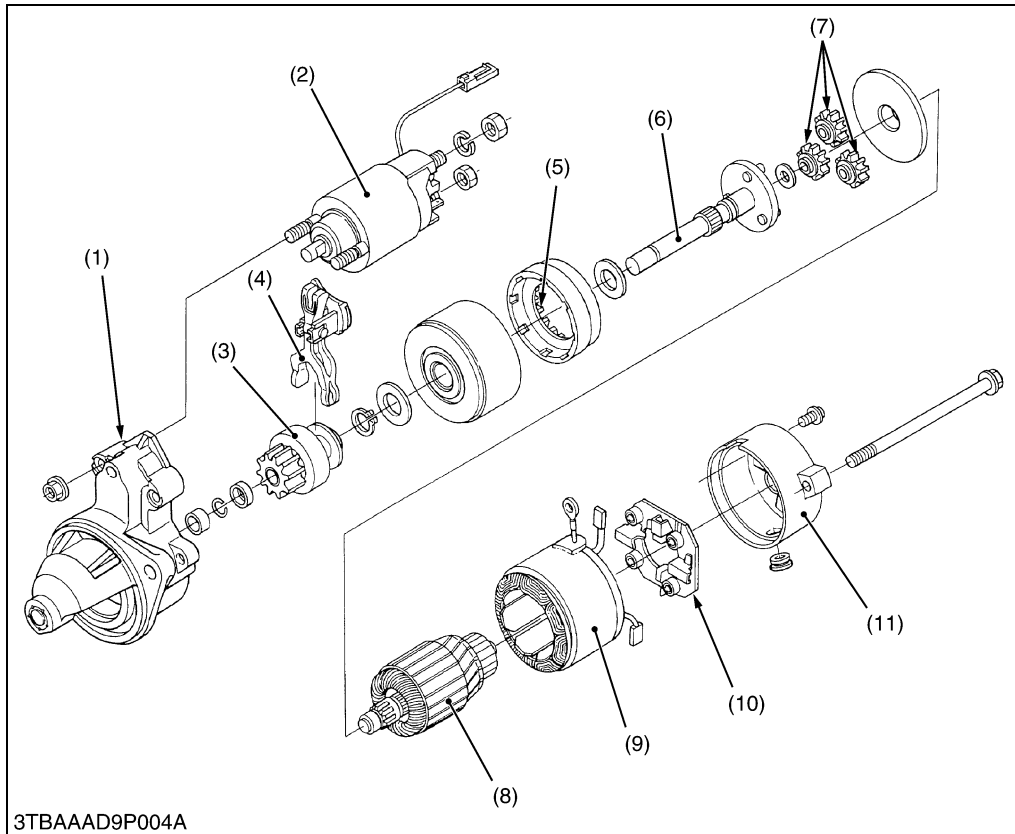

- (1) Housing
- (2) Magnetic Switch
- (3) Overrunning Clutch
- (4) Drive Lever
- (5) Internal Gear
- (6) Gear Shaft
- (7) Planetary Gear
- (8) Armature Shaft
- (9) Yoke
- (10) Brush Holder
- (11) Rear End Frame

3TBAAAD9P004A

The starter is a reduction type.

The reduction system is used planetary gears, and the speed of gear shaft (6) is reduced to approximately one fifth of the armature shaft (8).

9Y1210982ELM0019US0

[5] KEY STOP SOLENOID

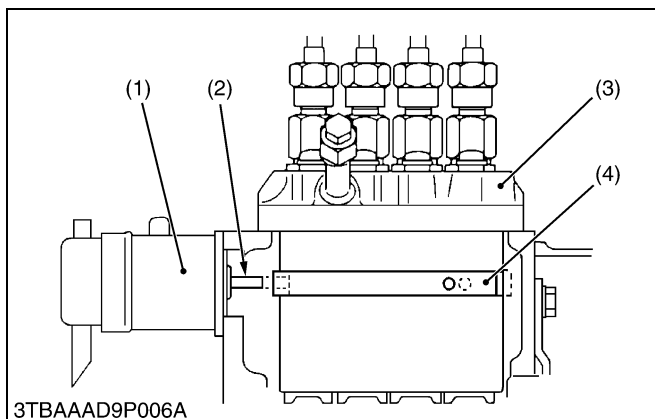

3TBAAAD9P006A

Flowing of the battery current into the fuel cut off solenoid, the plunger (2) move to left side so that the movement of control rack (4) becomes free. When the battery current stops, the plunger (2) is returned to the original position by the spring to keep the control rack (4) in **"No fuel injection"** position.

- (1) Key Stop Solenoid
- (2) Plunger
- (3) Injection Pump
- (4) Control Rack

9Y1210982ELM0020US0

[6] GLOW PLUG

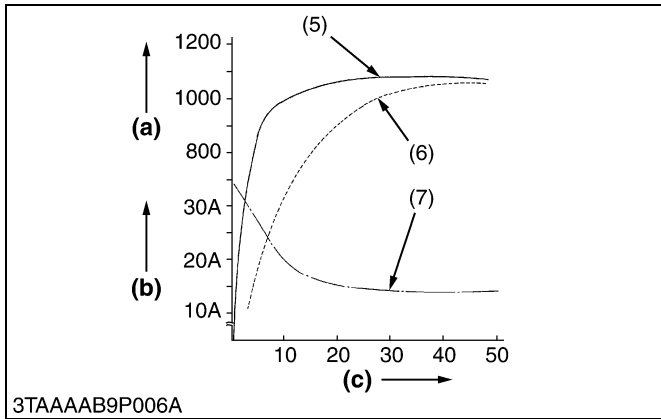
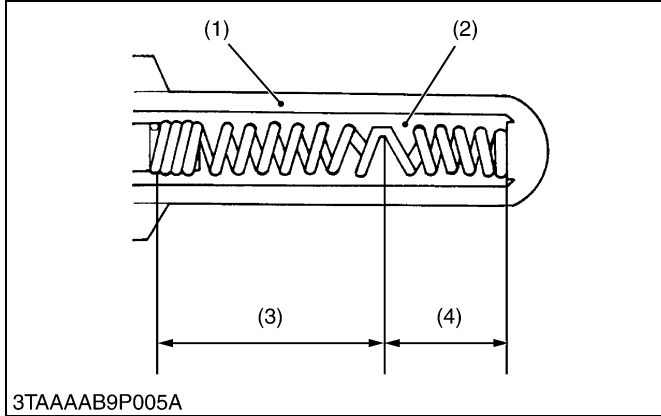

This plug is a two-material type QGS (Quick Glow System) for quick temperature rise, and has self-controlling function as well as excellent durability.

The heater (4) connected in series to the heater (3), which also functions as the resistor, is incorporated in the sheath tube (1) of the super glow plug.

The resistance of this heater (3) cum resistor is small when the temperature is low, while the resistance becomes large when the temperature rises.

Therefore, because sufficient current is flown to the heater (4) during the initial period of energization, the temperature rises quickly and the resistance grows with the rise in the temperature of the resistor, the flowing current is reduced to prevent the heater (4) from being heated.

The ignition point is in the area of 2 to 3 mm (0.079 to 0.118 in.) from the tip of the plug in order to reduce its projection into the combustion chamber.

- (1) Sheath Tube
 - (2) Insulation Powder
 - (3) Heater also functioning as a Resistor
 - (4) Heater
 - (5) Super Glow Plug
 - (6) Conventional Quick-heating type Glow Plug
 - (7) Glow Plug Current
- (a) Glow Plug Temperature (°C)
 - (b) Current (A)
 - (c) Time (Sec.)

9Y1210982ELM0021US0

3. CHARGING SYSTEM

Charging System Circuit (ROPS Model)

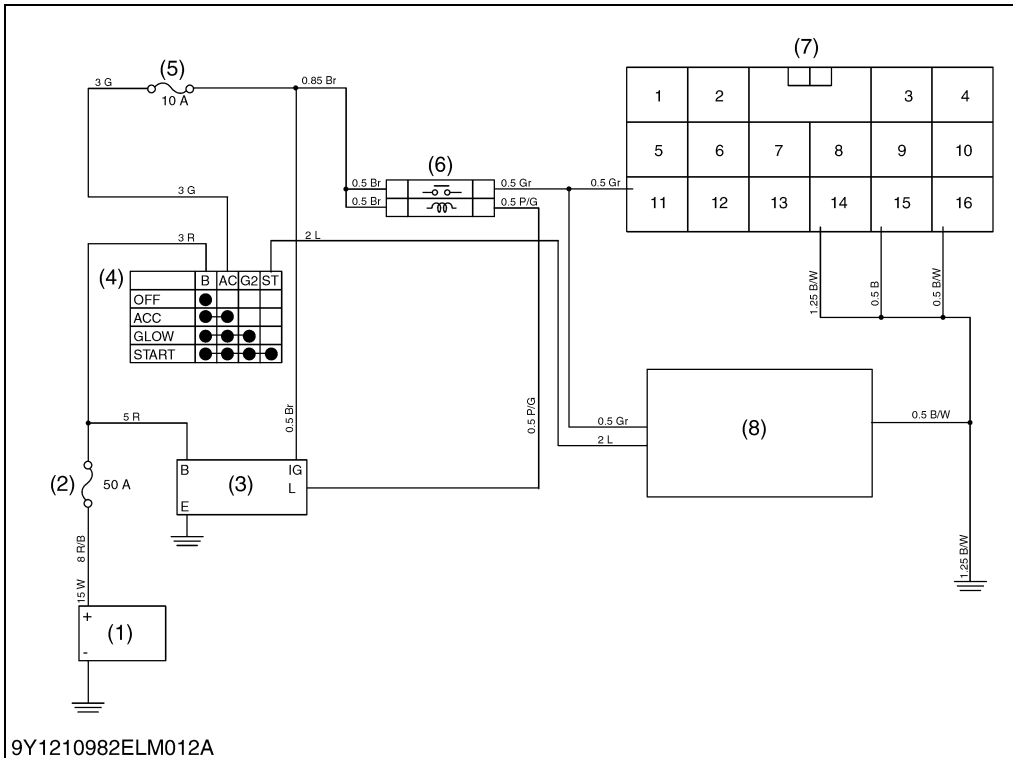

- (1) Battery
- (2) Slow Blow Fuse (Main)
- (3) Alternator
- (4) Key Switch
- (5) Fuse (Alternator / ACC Relay)
- (6) Relay (Charge)
- (7) Instrument Panel
- (8) OPC Controller

9Y1210982ELM012A

The charging system supplies electric power for various electrical devices and also charges the battery while the engine operates.

9Y1210982ELM0022US0

[2] IC REGULATOR

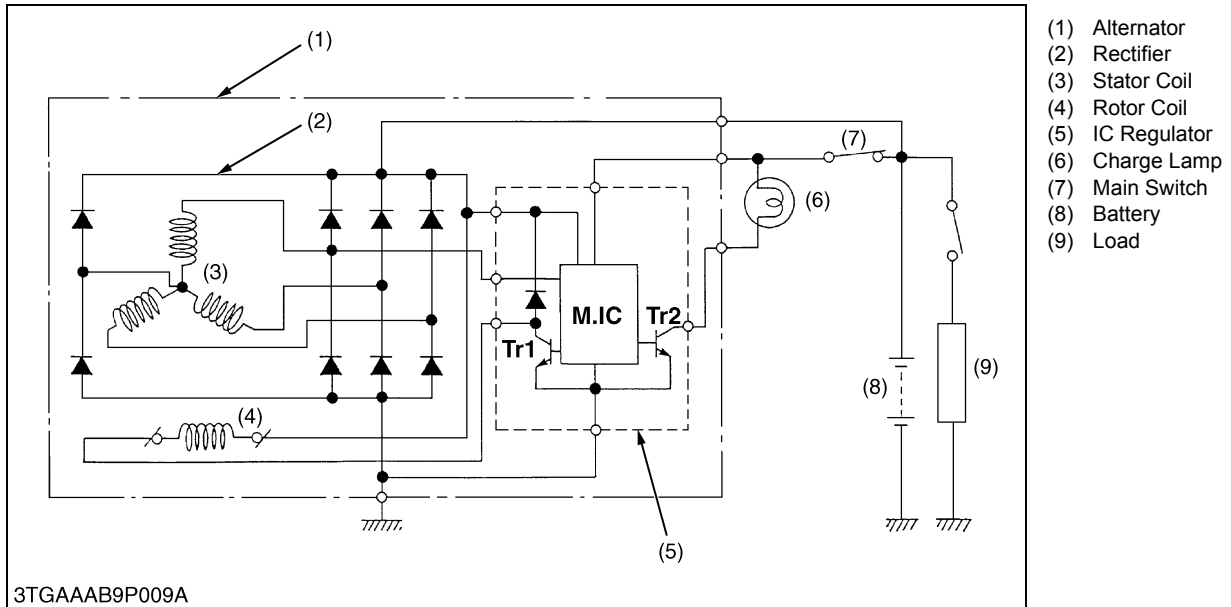

An IC regulator uses solid state transistors, chips or other semiconductor elements instead of the relays in a conventional regulator. Stable characteristics are achieved by cutting off the field current.

IC regulators have the following characteristics:

- The control voltage does not change over time, so the need for readjustment is eliminated. Since there are no moving parts, IC regulators are extremely durable and resistant to vibration.
- The overheat compensation characteristics ensure that the control voltage is reduced as the temperature rises, so the battery is charged at just the right level.

The internal circuitry of the IC regulator is shown in the diagram. It consists of a hybrid IC incorporating a monolithic IC. (The internal circuitry of the monolithic IC is extremely complex, so it is shown as simply "M.IC circuit".)

Tr1 acts as the contacts controlling the field current, and **Tr2** acts as the charge lamp relay controlling the flashing of the charge lamp.

The **M.IC** circuit controls **Tr1** and **Tr2**, and monitors the alternator output voltage, and detects any drop in **L** terminal voltage or breaks in the rotor coil.

9Y1210982ELM0025US0

[2] TURN SIGNAL LIGHT

ROPS Model

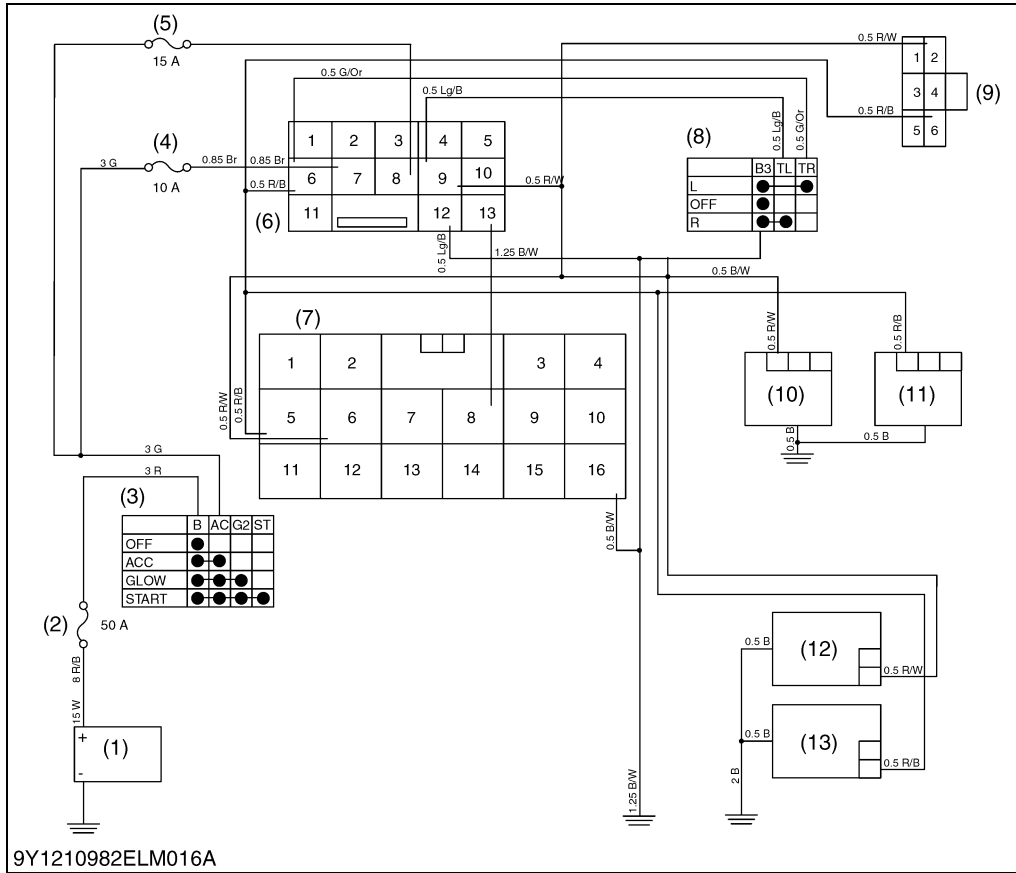

- (1) Battery
- (2) Slow Blow Fuse (Main)
- (3) Key Switch
- (4) Fuse (Alternator / ACC Relay)
- (5) Fuse (Flasher / Hazard)
- (6) Flasher Unit
- (7) Instrument Panel
- (8) Combination Switch (Turn Signal)
- (9) Trailer Socket
- (10) Rear Combination Lamp (L) (Turn)
- (11) Rear Combination Lamp (R) (Turn)
- (12) Front Combination Lamp (L) (Turn)
- (13) Front Combination Lamp (R) (Turn)

9Y1210982ELM0028US0

9Y1210982ELM016A

CABIN Model

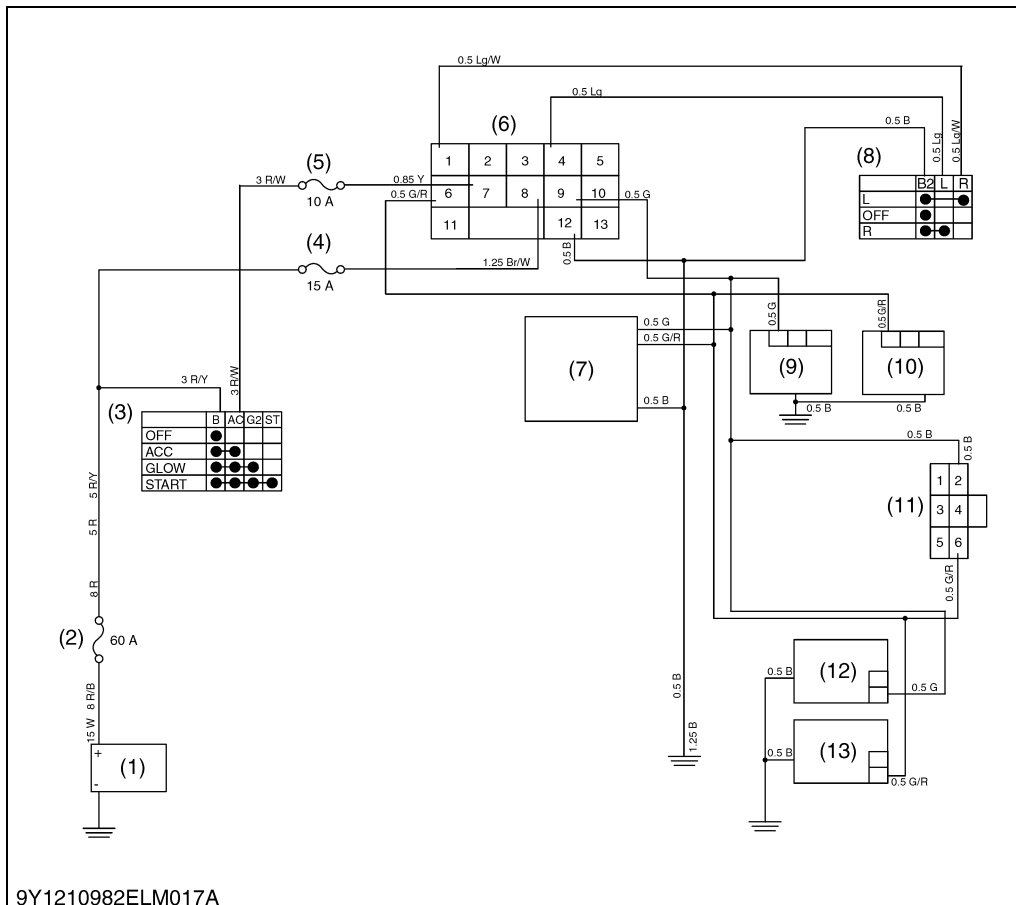

- (1) Battery
- (2) Slow Blow Fuse (Main)
- (3) Key Switch
- (4) Fuse (Alternator / ACC Relay)
- (5) Fuse (Flasher / Hazard)
- (6) Flasher Unit
- (7) Instrument Panel
- (8) Combination Switch (Turn Signal)
- (9) Rear Combination Lamp (L) (Turn)
- (10) Rear Combination Lamp (R) (Turn)
- (11) Trailer Socket
- (12) Front Combination Lamp (L) (Turn)
- (13) Front Combination Lamp (R) (Turn)

9Y1210982ELM0029US0

9Y1210982ELM017A

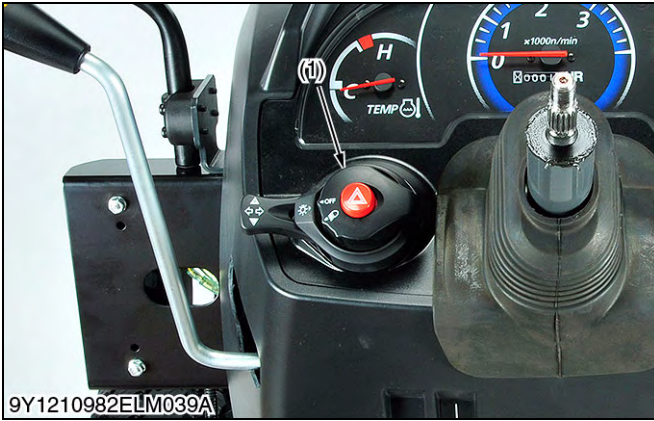

9Y1210982ELM039A

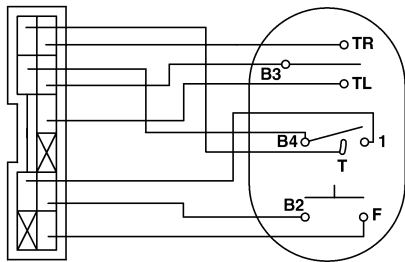

9Y1210982ELM018A

Combination Switch (ROPS Model)

Combination switch consist of head light switch, turn signal light switch and horn switch.

Head Light Switch

	B4	T	1
OFF	●		
ON	●	●	●

9Y1210982ELM032US

Turn Signal Light Switch

	B3	TL	TR
L	●	●	
OFF	●		
R	●		●

9Y1210982ELM033US

Hazard Switch

	F	B2
OFF	●	
ON	●	●

9Y1210982ELM034US

(1) Combination Switch

9Y1210982ELM0030US0

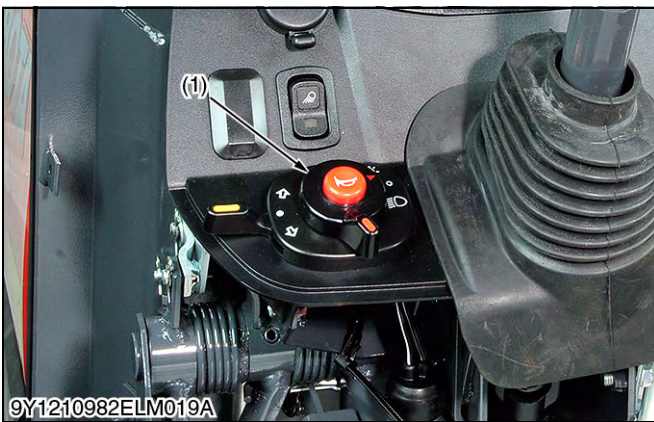

9Y1210982ELM019A

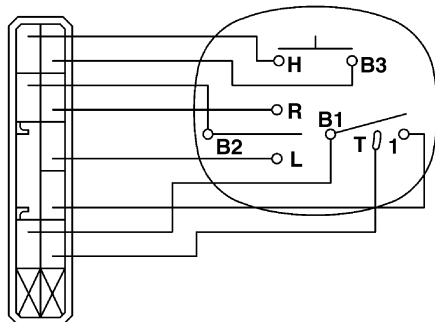

9Y1210982ELM020A

Combination Switch (CABIN Model)

Combination switch consist of head light switch, turn signal light switch and horn switch.

Head Light Switch

	B1	T	1
OFF	●		
ON	●	●	●

9Y1210982ELM035US

Turn Signal Light Switch

	B2	R	L
R	●	●	
OFF	●		
L	●		●

9Y1210982ELM036US

Horn Switch

	B3	H
OFF	●	
ON	●	●

9Y1210982ELM037US

(1) Combination Switch

9Y1210982ELM0031US0

[3] HAZARD LIGHT

ROPS Model

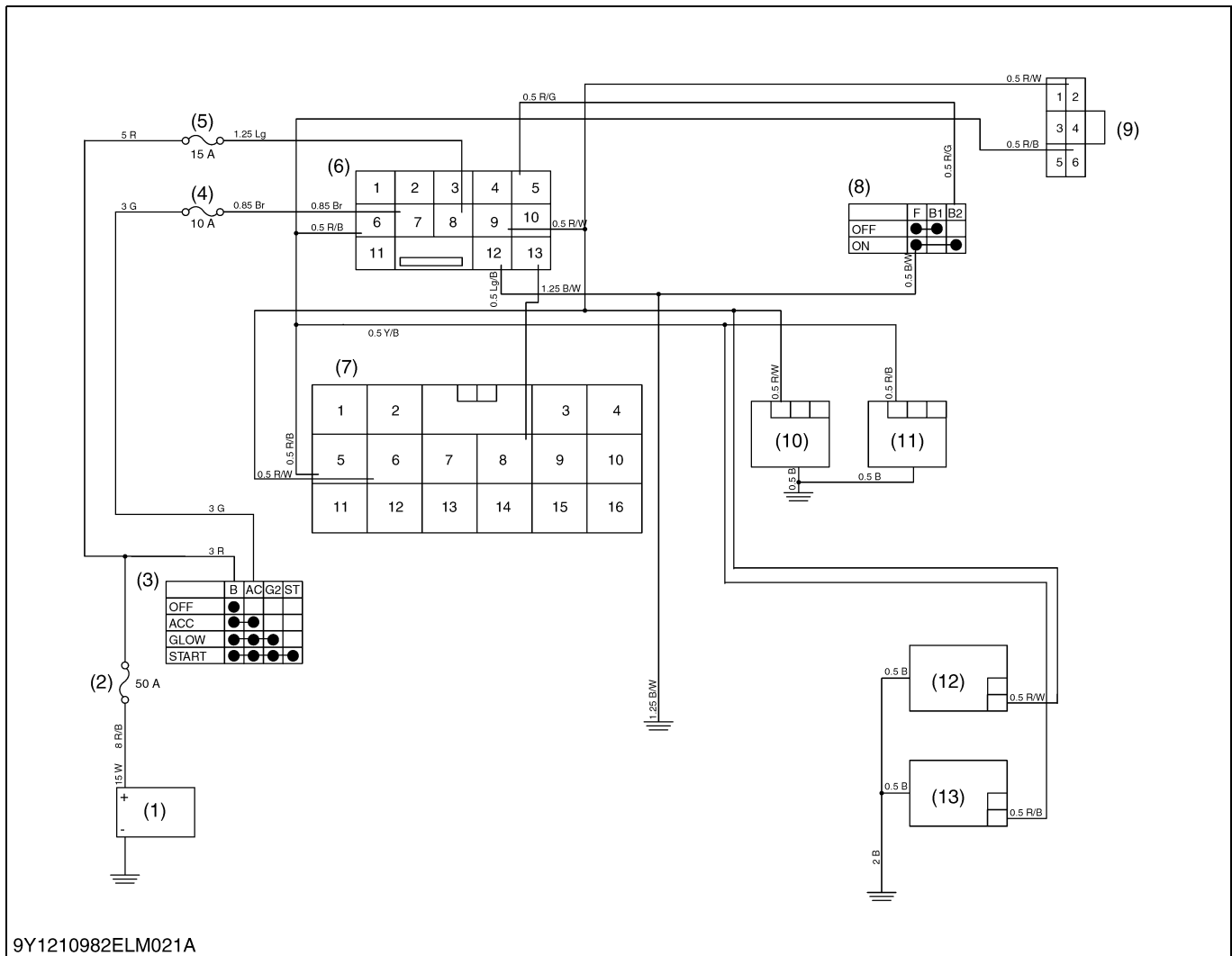

9Y1210982ELM021A

- (1) Battery
- (2) Slow Blow Fuse (Main)
- (3) Key Switch
- (4) Fuse (Alternator / ACC Relay)
- (5) Fuse (Flasher / Hazard)
- (6) Flasher Unit
- (7) Instrument Panel
- (8) Hazard Switch
- (9) Trailer Socket
- (10) Rear Combination Lamp (L) (Turn)
- (11) Rear Combination Lamp (R) (Turn)
- (12) Front Combination Lamp (L) (Turn)
- (13) Front Combination Lamp (R) (Turn)

9Y1210982ELM0032US0

CABIN Model

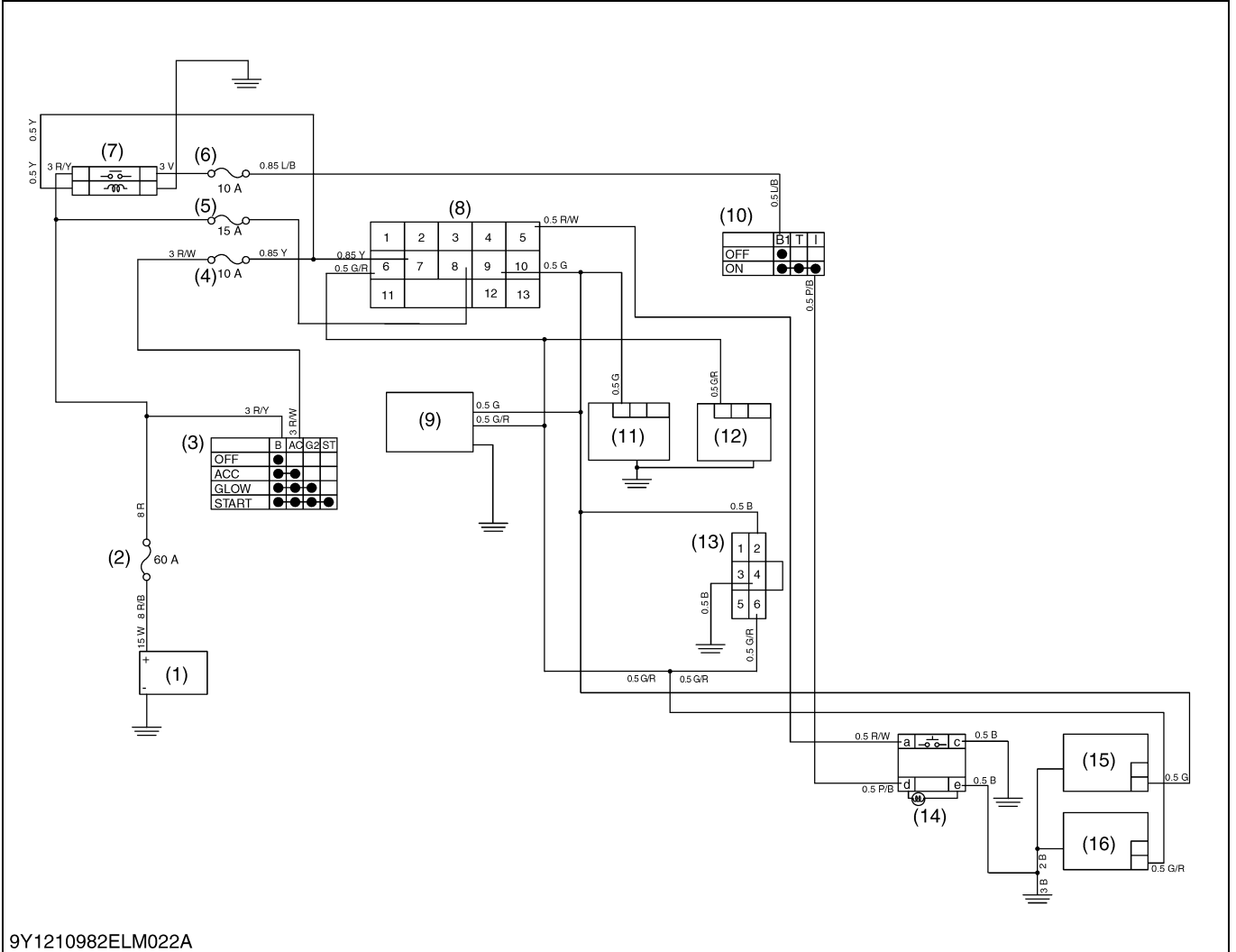

- | | | | |
|-----------------------------------|--|--|--|
| (1) Battery | (6) Fuse (Head Light / Position Lamp / Horn) | (10) Combination Switch (Head Light) | (13) Trailer Socket |
| (2) Slow Blow Fuse (Main) | (7) Relay (Head Light 1) | (11) Rear Combination Lamp (L) (Turn) | (14) Hazard Switch |
| (3) Key Switch | (8) Flasher Unit | (12) Rear Combination Lamp (R) (Turn) | (15) Front Combination Lamp (L) (Turn) |
| (4) Fuse (Alternator / ACC Relay) | (9) Instrument Panel | (16) Front Combination Lamp (R) (Turn) | |
| (5) Fuse (Flasher / Hazard) | | | |

9Y1210982ELM0033US0

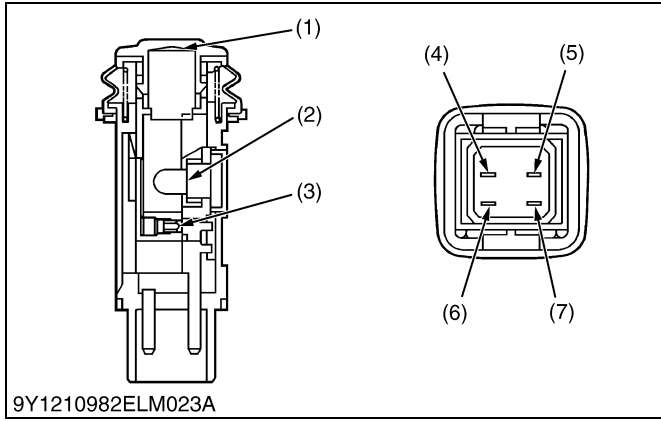

Hazard Switch (CABIN Model)

■ **NOTE**

- Refer to the page 9-S26 for the hazard switch (CABIN Model)

This is a pushing type switch to turn on the hazard lights. The lamp (2) in the switch is lighted up by the current from outside of the switch. The circuit in the switch is shown below.

Terminal	a	c	Lamp	
			d	e
OFF		●	●	●
ON	●	●	●	●

9Y1210982ELM038US

- (1) Lens
- (2) Lamp
- (3) Contact Portion
- (4) Terminal a
- (5) Terminal d
- (6) Terminal c
- (7) Terminal e

9Y1210982ELM0034US0

[4] BEACON

ROPS Model

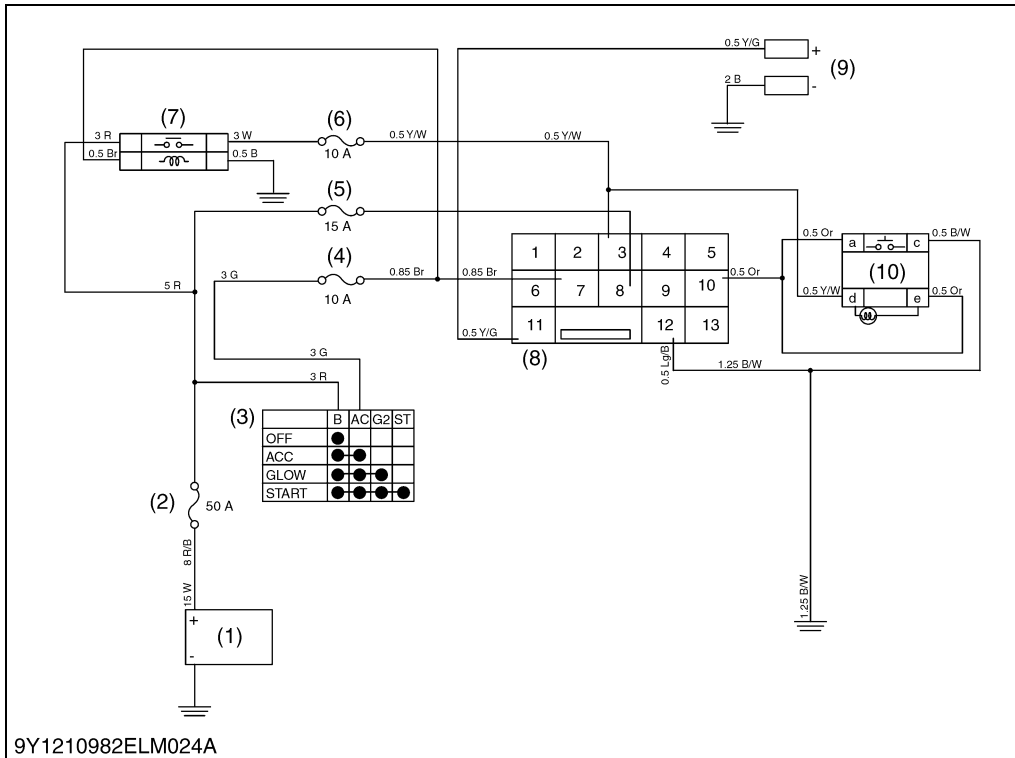

- (1) Battery
- (2) Slow Blow Fuse (Main)
- (3) Key Switch
- (4) Fuse (Alternator / ACC Relay)
- (5) Fuse (Flasher / Hazard)
- (6) Fuse (Beacon)
- (7) Relay (AUX)
- (8) Flasher Unit
- (9) Beacon
- (10) Beacon Switch

9Y1210982ELM0035US0

9Y1210982ELM024A

CABIN Model

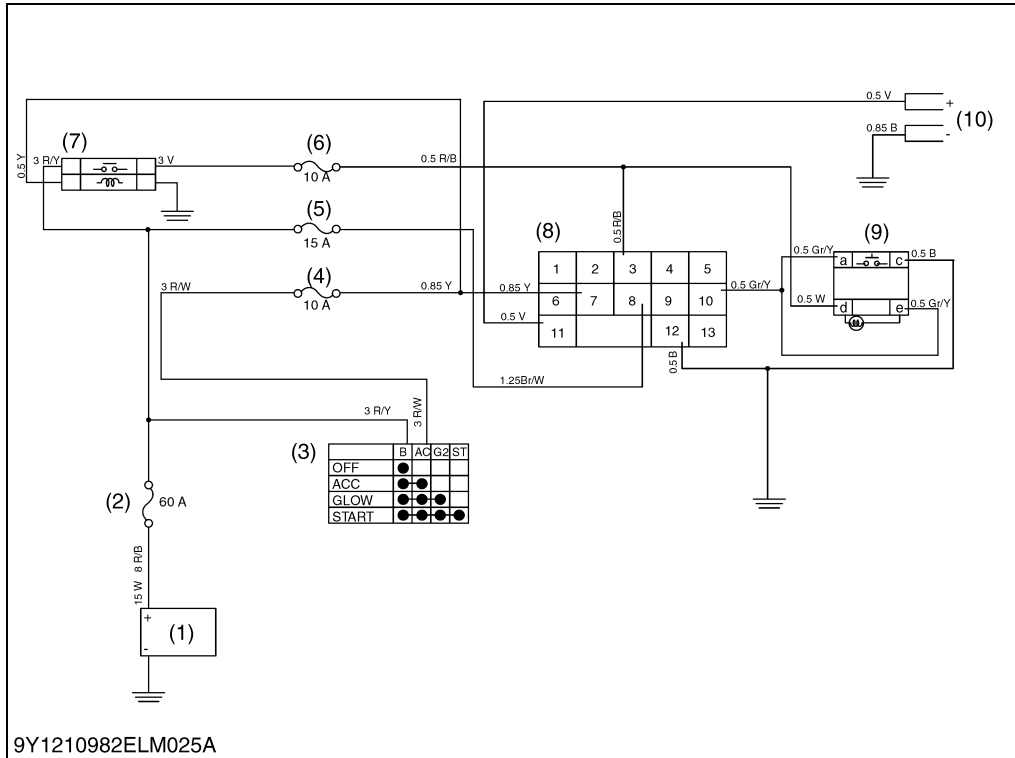

- (1) Battery
- (2) Slow Blow Fuse (Main)
- (3) Key Switch
- (4) Fuse (Alternator / ACC Relay)
- (5) Fuse (Flasher / Hazard)
- (6) Fuse (Beacon)
- (7) Relay (Head Light 1)
- (8) Flasher Unit
- (9) Beacon Switch
- (10) Beacon

9Y1210982ELM0036US0

9Y1210982ELM025A

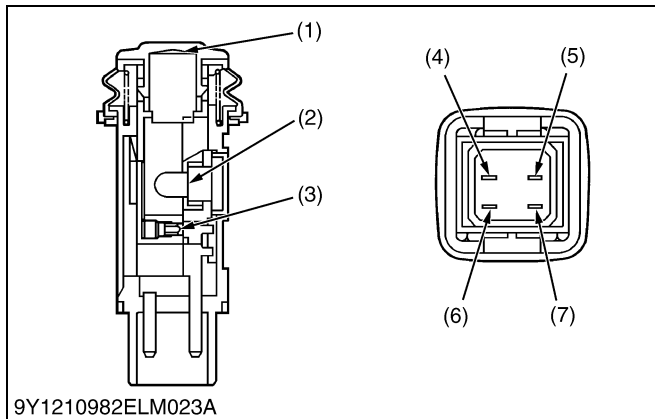

9Y1210982ELM023A

Beacon Switch

This is a pushing type switch to turn on the beacon. The lamp (2) in the switch is lighted up by the current from outside of the switch. The circuit in the switch is shown below.

Terminal	a	c	Lamp	
			d	e
OFF		●	●	●
ON	●	●	●	●

9Y1210982ELM038US

- (1) Lens
- (2) Lamp
- (3) Contact Portion
- (4) Terminal a
- (5) Terminal d
- (6) Terminal c
- (7) Terminal e

9Y1210982ELM0037US0

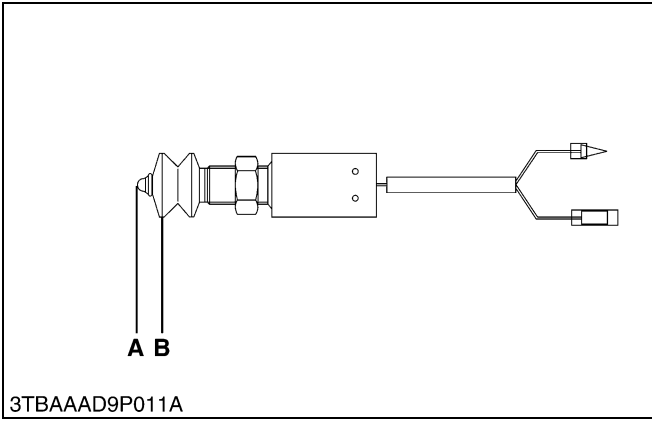

Brake Lamp Switch

Brake lamp switch is turned on by pushing a brake pedal and turned off by releasing it.

A: ON

B: OFF

9Y1210982ELM0040US0

[6] WORK LIGHT (CABIN MODEL ONLY)

CABIN Model

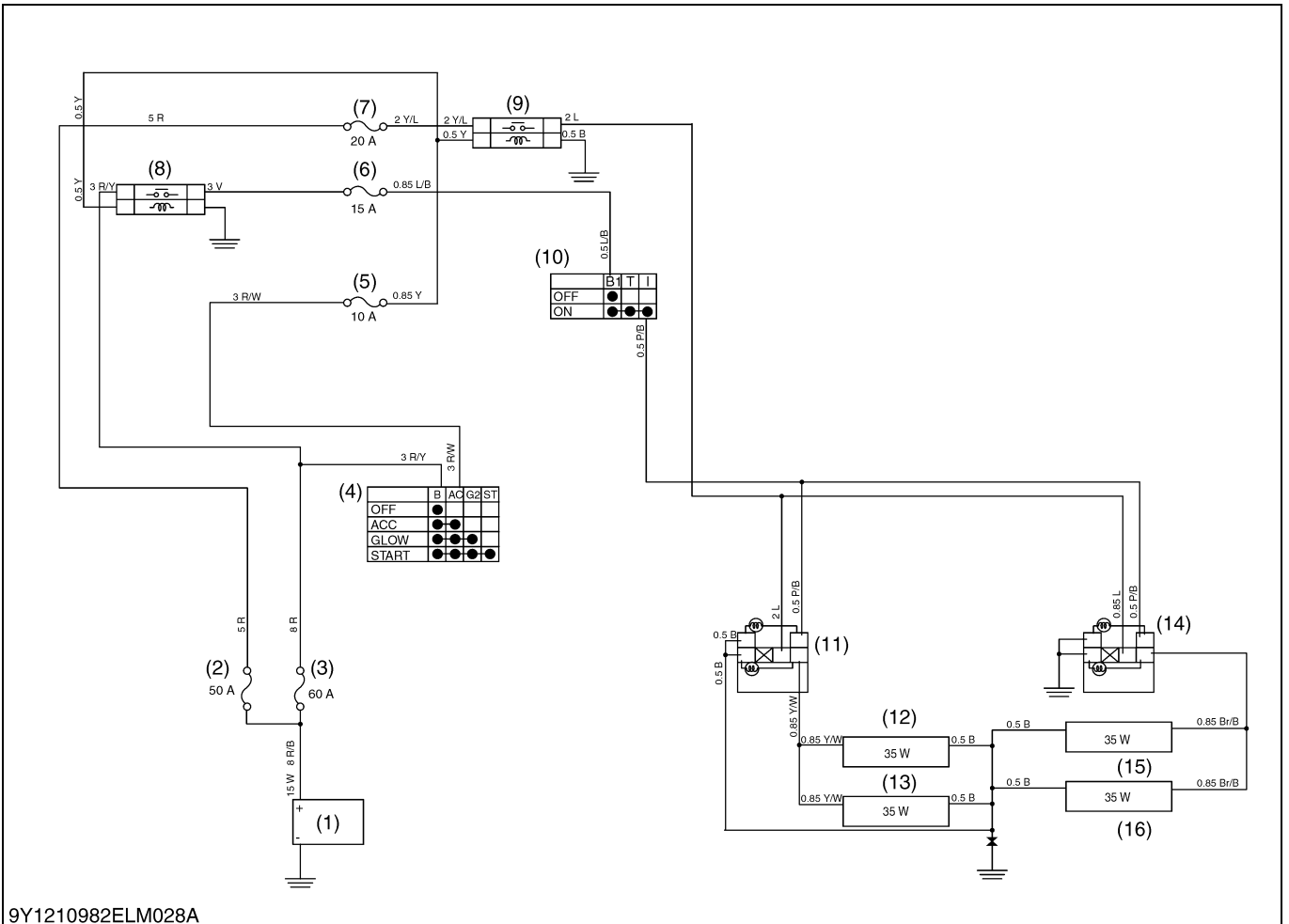

9Y1210982ELM028A

- | | | | |
|-----------------------------------|--|--------------------------------------|-----------------------------------|
| (1) Battery | (6) Fuse (Head Light / Position Lamp / Horn) | (10) Combination Switch (Head Light) | (13) Front Work Light (R) |
| (2) Slow Blow Fuse (CABIN) | (7) Relay (Work Light) | (11) Front Work Light Switch | (14) Rear Work Light Switch |
| (3) Slow Blow Fuse (Main) | (8) Relay (Head Light 1) | (12) Front Work Light (L) | (15) Rear Work Light (L) (Option) |
| (4) Key Switch | (9) Relay (Work Light) | | (16) Rear Work Light (R) (Option) |
| (5) Fuse (Alternator / ACC Relay) | | | |

9Y1210982ELM0041US0

[7] TRAILER SOCKET

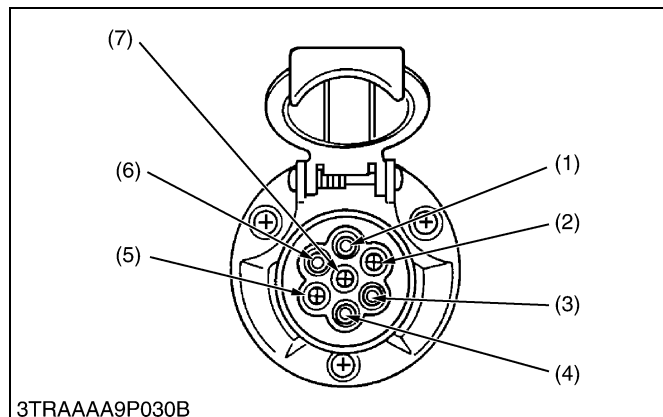

The trailer socket is provided to remove the electrical power from tractor to trailer or implement.

The function of each terminal is shown below.

Terminal	Function	Color of wire harness
(1)	Turn signal (L)	Green / White
(2)	–	–
(3)	Ground	Black
(4)	Turn signal (R)	Red / White
(5)	Position (R)	Yellow / Red
(6)	Brake	Yellow
(7)	Position (L)	Yellow / White

(1) Terminal 1

(2) Terminal 2

(3) Terminal 3

(4) Terminal 4

(5) Terminal 5

(6) Terminal 6

(7) Terminal 7

9Y1210982ELM0042US0

5. INSTRUMENT PANEL

[1] EASY CHECKER™

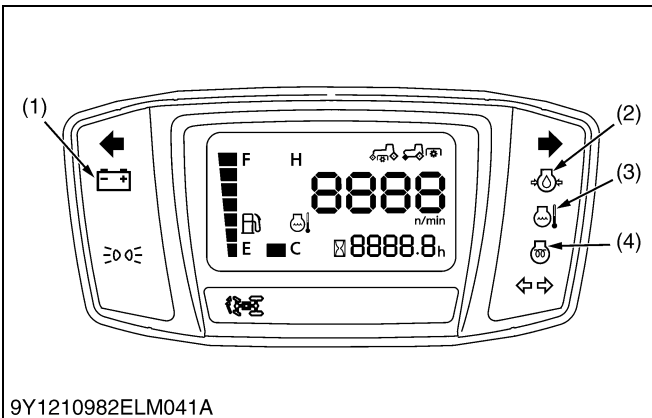
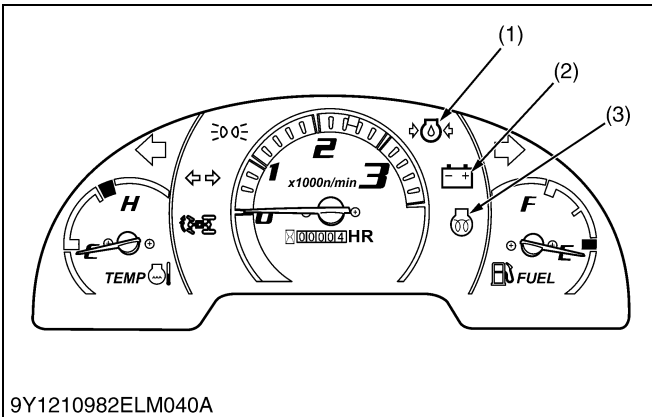

ROPS Model

If the warning lamps of the Easy Checker™ come on during operation, immediately stop the engine, and find the cause as shown below.

Never operate the machine while Easy Checker™ lamp is on.

■ Electrical Charge Warning Indicator

If the alternator is not charging the battery, the warning lamp in the Easy Checker™ will come on.

If this should happen during operation, check the electrical charging system.

■ Glow Plug Indicator

When the key switch is in the "PREHEAT" position, the glow plug indicator illuminates.

■ Engine Oil Pressure Warning Indicator

If the oil pressure in the engine goes below 49 kPa (0.5 kgf/cm², 7 psi), the warning lamp in the Easy Checker™ will come on.

- (1) Engine Oil Pressure Warning Indicator (2) Electrical Charge Warning Indicator (3) Glow Plug Indicator

9Y1210982ELM0043US0

CABIN Model

If the warning lamps of the Easy Checker™ come on during operation, immediately stop the engine, and find the cause as shown below.

Never operate the machine while Easy Checker™ lamp is on.

■ Electrical Charge Warning Indicator

If the alternator is not charging the battery, the warning lamp in the Easy Checker™ will come on.

If this should happen during operation, check the electrical charging system.

■ Glow Plug Indicator

When the key switch is in the "PREHEAT" position, the glow plug indicator illuminates.

■ Engine Oil Pressure Warning Indicator

If the oil pressure in the engine goes below 49 kPa (0.5 kgf/cm², 7 psi), the warning lamp in the Easy Checker™ will come on.

■ Engine Overheat Warning Indicator

If the coolant temperature goes up above 125 °C (257 °F), the warning lamp in the Easy Checker™ will come on.

- (1) Electrical Charge Warning Indicator (2) Engine Oil Pressure Warning Indicator (3) Engine Overheat Warning Indicator (4) Glow Plug Indicator

9Y1210982ELM0044US0

[2] GAUGES AND OTHER INDICATORS

ROPS Model

- (1) Coolant Temperature Gauge (3) Bi-speed Turn Indicator
- (2) Fuel Gauge

9Y1210982ELM0045US0

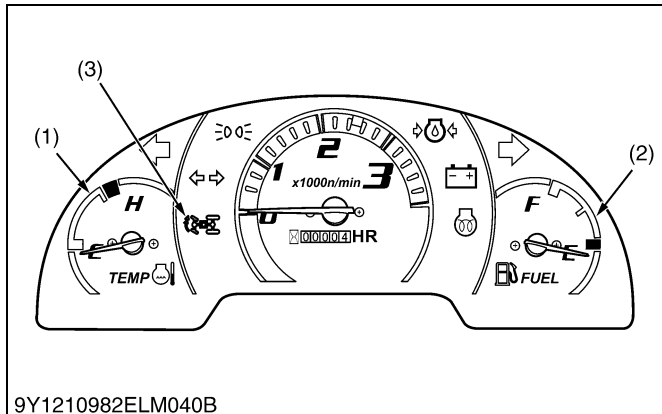

9Y1210982ELM040B

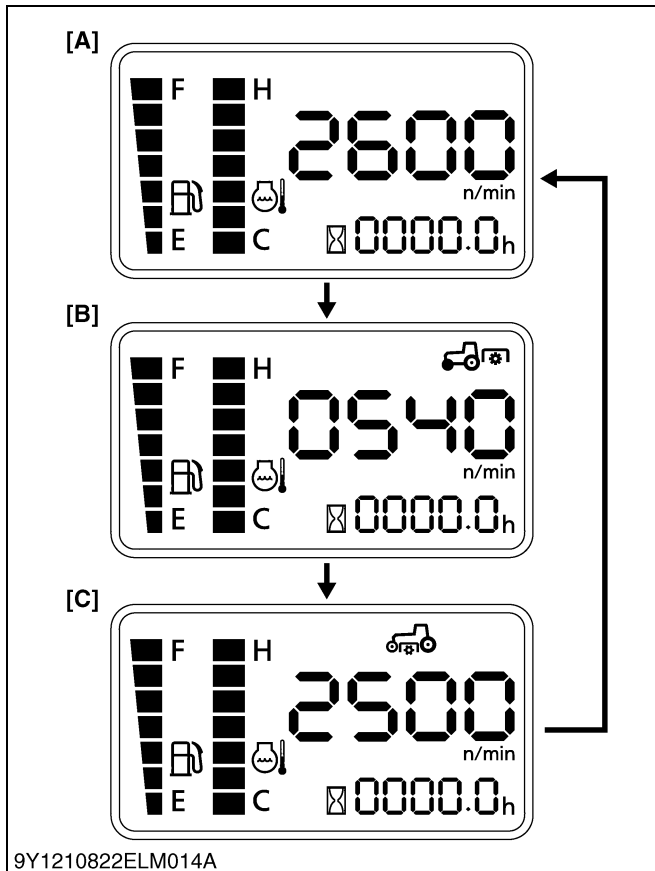
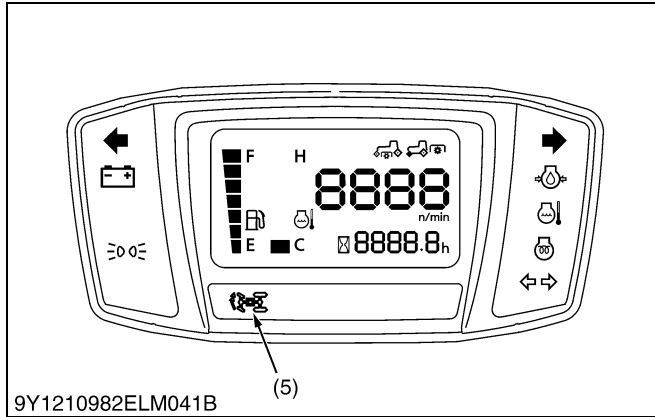
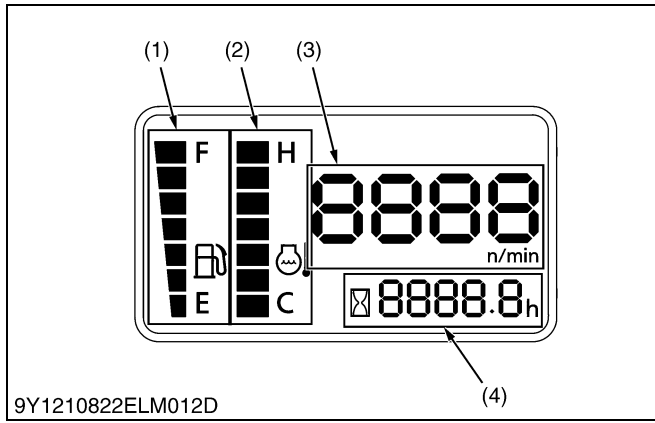

CABIN Model

The engine speed / PTO speed indicator (3) indicates the engine speed or the PTO speed selectively.

The engine speed / PTO speed indicator (3) shows "Engine Speed" as default when the main switch is turned ON.

Every time the display switch (6) is pressed, the display changes to "Rear PTO Speed", "Mid PTO Speed", "Engine Speed" alternately.

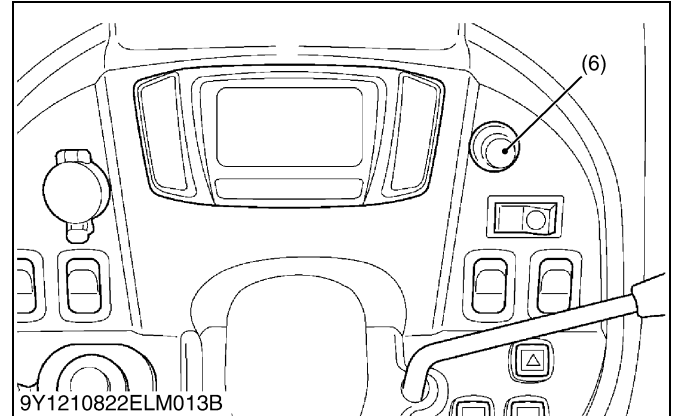

- (1) Fuel Gauge
 - (2) Coolant Temperature Gauge
 - (3) Engine Speed / PTO Speed Indicator
 - (4) Hour meter
 - (5) Bi-speed Turn Indicator
 - (6) Display Switch
- [A] Engine Speed
 - [B] Rear PTO Speed
 - [C] Mid PTO Speed

9Y1210982ELM0046US0

[3] ERROR CODE DISPLAY (CABIN MODEL ONLY)

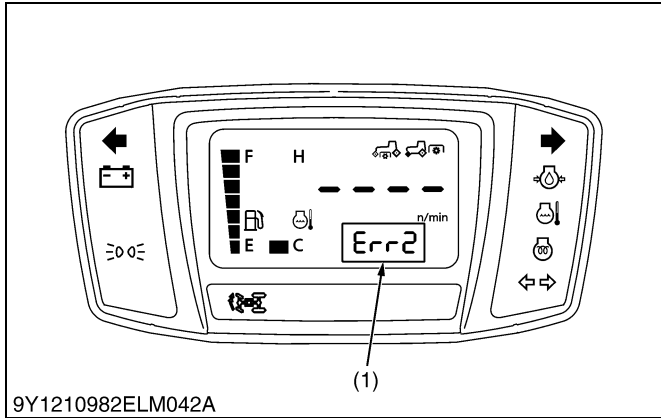

If trouble should occur at the instrument panel error code appears as a warning.

If the trouble is not corrected by restarting the machine, solve the problem according to the following table.

■ **NOTE**

- This error code is detecting the internal circuit problem in the instrument panel.

(1) Error Code

Error code	Trouble	Check point or solution
Err 1	Water temperature sensor power circuit trouble	Checking battery voltage or replacing meter panel
Err 2	Fuel sensor power circuit trouble	Checking battery voltage or replacing meter panel
Err 3	Meter panel memory reading trouble	Replacing meter panel

9Y1210982ELM0047US0

[4] SWITCHES AND SENSORS

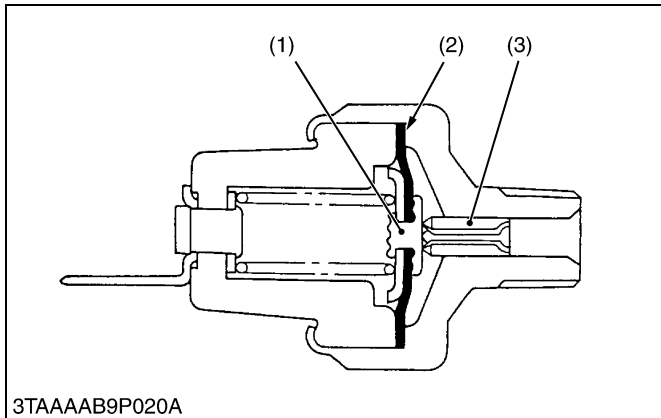

Oil Pressure Switch

While oil pressure is high and the force applied to the diaphragm (2) is larger than the spring tension, the terminal contact (1) is open separated from the body contact (3). If the pressure drops below approx. 49 kPa (0.5 kgf/cm², 7.1 psi), the contact closes.

- (1) Terminal Contact
- (2) Diaphragm
- (3) Body Contact

9Y1210982ELM0048US0

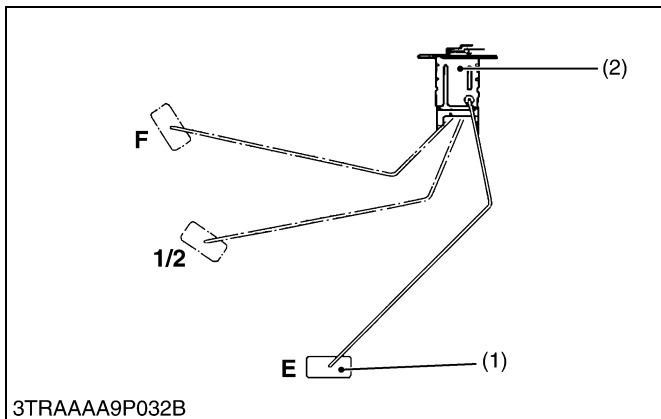

Fuel Sensor

The remaining fuel quantity is detected by the fuel level sensor installed in the fuel tank and indicated on the fuel gauge. For detection, a float and a resistor are used.

As the float (1) lowers, the resistance of the variable resistor (2) varies. The relation between the amount of fuel and the resistance is as follows.

F	1/2	E
2 to 4 Ω	29 to 36 Ω	109 to 111 Ω

- (1) Float
- (2) Variable Resistor

9Y1210982ELM0049US0

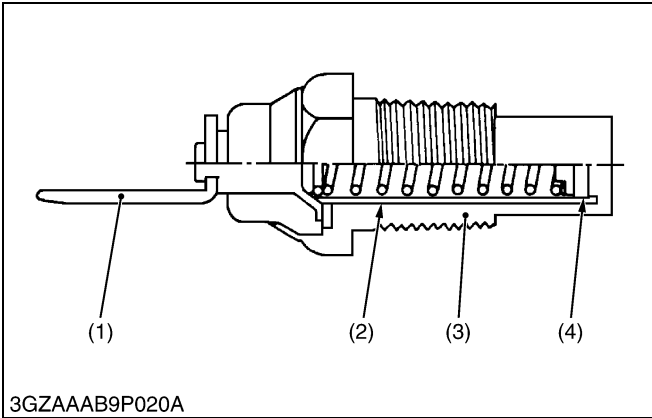

Coolant Temperature Sensor (ROPS Model)

The coolant temperature sensor is installed to the cylinder head of engine, and its tip is in touch with the coolant. It contains a thermistor (4) whose electrical resistance decreases as the temperature increases.

Current varies with changes in the coolant temperature, and the increases or decreases in the current move the pointer of gauge.

Characteristics of Thermistor	
Temperature	Resistance
50 °C (122 °F)	148.8 Ω
80 °C (176 °F)	50.3 Ω
120 °C (248 °F)	16.0 Ω
170 °C (338 °F)	5.6 Ω

- (1) Terminal
- (2) Insulator
- (3) Body
- (4) Thermistor

9Y1210982ELM0050US0

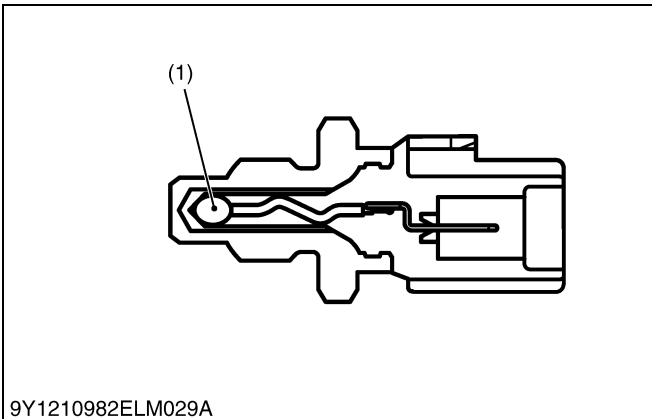

Coolant Temperature Sensor (CABIN Model)

The coolant temperature sensor is installed to the cylinder head of engine, and its tip is in touch with the coolant. It contains a thermistor (1) whose electrical resistance decreases as the temperature increases.

Resistance	at -20 °C (-4 °F)	Approx. 15.0 kΩ
	at 20 °C (68 °F)	Approx. 2.45 kΩ
	at 80 °C (176 °F)	Approx. 0.318 kΩ

- (1) Thermistor

9Y1210982ELM0051US0

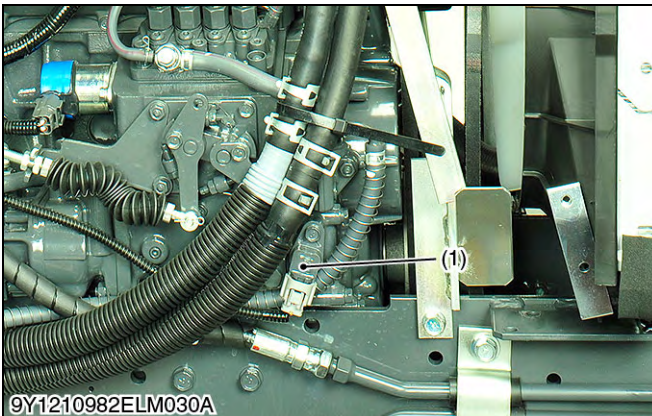

Engine Rotation Sensor (CABIN Model Only)

The engine rotation sensor detects the governor gear rotation.

Then the instrument panel calculates and displays the engine speed and PTO speed.

- (1) Engine Rotation Sensor

9Y1210982ELM0052US0

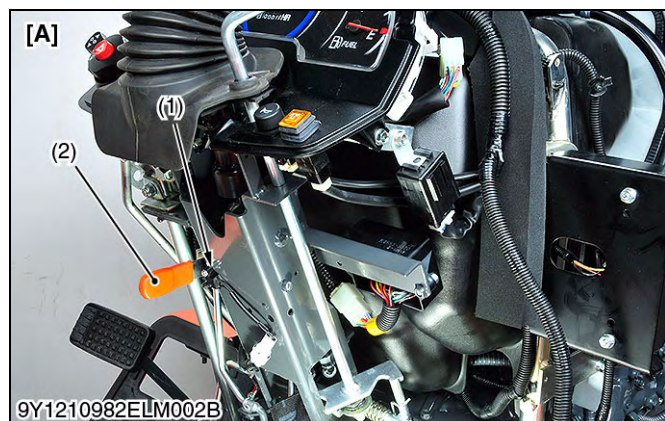

Bi-speed Turn Switch

This switch is a push type.

This switch detects the position of the bi-speed turn lever.

When the bi-speed turn lever is at "**Bi-speed turn 4WD**" position, this switch is turned to "**ON**".

When the bi-speed turn lever is at "**Normal 4WD**" position, this switch is turned to "**OFF**".

- (1) Bi-speed Turn Switch
- (2) Bi-speed Turn Lever

- [A] ROPS Model
- [B] CABIN Model

9Y1210982ELM0053US0

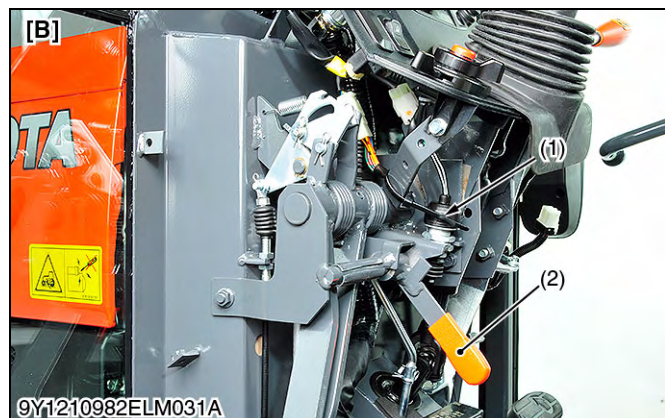

SERVICING

CONTENTS

1. TROUBLESHOOTING.....	9-S1
2. SERVICING SPECIFICATIONS.....	9-S7
3. TIGHTENING TORQUES.....	9-S8
4. CHECKING AND ADJUSTING.....	9-S9
[1] BATTERY.....	9-S9
[2] FUSE.....	9-S10
[3] RELAYS.....	9-S11
(1) Relays (ROPS Model).....	9-S11
(2) Relays (CABIN Model).....	9-S13
[4] STARTING SYSTEM.....	9-S15
(1) Key Switch.....	9-S15
(2) Safety Switches.....	9-S17
(3) OPC Controller.....	9-S18
(4) Key Stop Solenoid.....	9-S18
(5) Starter.....	9-S19
(6) Glow Plug.....	9-S20
[5] CHARGING SYSTEM.....	9-S21
(1) Alternator.....	9-S21
[6] LIGHTING SYSTEM.....	9-S22
(1) Combination Switch (ROPS Model).....	9-S22
(2) Combination Switch (CABIN Model).....	9-S24
(3) Hazard Switch (Cabin Model Only).....	9-S26
(4) Beacon Switch.....	9-S27
(5) Flasher Unit.....	9-S28
(6) Brake Lamp Switch.....	9-S29
(7) Work Light Switch (CABIN Model Only).....	9-S30
(8) Dome Light (CABIN Model Only).....	9-S31
[7] WARNING LAMP, INDICATOR LAMP AND GAUGE.....	9-S32
(1) Instrument Panel (ROPS Model).....	9-S32
(2) Instrument Panel (CABIN Model).....	9-S33
(3) Engine Oil Pressure Switch.....	9-S34
(4) Coolant Temperature Sensor (ROPS Model).....	9-S35
(5) Coolant Temperature Sensor (CABIN Model).....	9-S36
(6) Fuel Sensor.....	9-S37
(7) Bi-speed Turn Switch.....	9-S37
(8) Engine Rotation Sensor (CABIN Model Only).....	9-S38
(9) Display Switch.....	9-S39
5. DISASSEMBLING AND ASSEMBLING.....	9-S40
[1] STARTER.....	9-S40
[2] ALTERNATOR.....	9-S40
6. SERVICING.....	9-S43
[1] STARTER.....	9-S43
[2] ALTERNATOR.....	9-S44

1. TROUBLESHOOTING

FUSE AND WIRING

Symptom	Probable Cause and Checking Procedure	Solution	Reference Page
All Electrical Equipment Do Not Operate	1. Battery discharged or damaged	Check or recharge battery	9-S10
	2. Battery positive cable disconnected or improperly connected	Repair or replace battery positive cable	9-S9
	3. Battery negative cable disconnected or improperly connected	Repair or replace negative cable	9-S9
	4. Slow blow fuse blown	Repair main harness or glow, ECU harness	9-M1 to 9-M3
Fuse Blown Frequently	1. Short-circuited	Repair or replace fuse	G-40

BATTERY

Symptom	Probable Cause and Checking Procedure	Solution	Reference Page
Battery Discharges Too Quickly	1. Battery damaged	Recharge or replace battery	9-S10
	2. Alternator damaged	Repair or replace alternator	9-S40
	3. Regulator damaged	Replace regulator	9-M18
	4. Wiring harness disconnected or improperly connected	Repair or replace connector and wire harness	9-M1 to 9-M3
	5. Cooling fan belt slipping	Adjust fan belt	G-26

STARTING SYSTEM

Symptom	Probable Cause and Checking Procedure	Solution	Reference Page	
Starter Motor Does Not Operate	1. Battery discharged or damaged	Recharge or replace battery	9-S10	
	2. Slow blow fuse blown	Replace main harness or other	9-M1 to 9-M3	
	3. Safety switch improperly adjusted or damaged	Repair or replace safety switch	9-S17	
	4. Wiring harness disconnected or improperly connected	Repair or replace connector and wire harness	9-M1 to 9-M3	
	5. Starter relay damaged	Replace starter relay	9-S11	
	6. Starter motor damaged		Solution order 1. Check starter motor	9-S40
			2. Replace starter motor	9-S40
7. Main switch damaged	Check or replace main switch	9-S22		

Symptom	Probable Cause and Checking Procedure	Solution	Reference Page
Pre-heat indicator Lamp Does Not Light When Main Switch Is in Pre-heat Position	1. Battery discharged or damaged	Recharge or replace battery	9-S10
	2. Slow blow fuse blown	Repair glow harness or other	9-M1 to 9-M3
	3. Wiring harness disconnected or improperly connected	Repair or replace connector and wire harness	9-M1 to 9-M3
	4. Main switch damaged	Check or replace main switch	9-S22
	5. Glow plug indicator damaged	Replace main panel	9-S32

OPERATOR PRESENCE CONTROL (OPC)

Symptom	Probable Cause and Checking Procedure	Solution	Reference Page
Engine Does Not Stop	1. Solenoid fuse blown (30 A)	Repair wire harness or other	G-40, 9-M1 to 9-M3
	2. Key stop solenoid relay damaged	Replace key stop solenoid relay	9-S11
	3. Key stop solenoid damaged	Replace key stop solenoid	9-S18
	4. Operator presence controller damaged	Check or replace operator presence controller	9-S18
	5. PTO select lever switch damaged	Check or replace PTO select lever switch	9-S17
	6. PTO lever switch damaged	Check or replace PTO lever switch	9-S17
	7. Shuttle shift lever switch damaged	Check or replace shuttle shift lever switch	9-S17
	8. HST pedal switch damaged	Check or replace HST pedal switch	9-S17
	9. Parking brake switch damaged	Check or replace parking brake switch	9-S17
	10. Relay damaged	Replace relay	9-S11
	11. Wiring harness disconnected or improperly connected (between key stop solenoid relay and key stop solenoid, between key stop solenoid relay between main switch and operator presence controller, between safety switches and operator presence controller and battery positive terminal)	Repair or replace connector and wire harness	9-M1 to 9-M3
	12. Wiring harness disconnected or improperly connected (between operator presence controller and key stop solenoid relay)	Repair or replace connector and wire harness	9-M1 to 9-M3

Symptom	Probable Cause and Checking Procedure	Solution	Reference Page
Starter Motor Does Not Operate	1. Solenoid fuse blown (30 A)	Replace wire harness or other	9-M1 to 9-M3
	2. Key stop solenoid damaged	Check key stop solenoid	9-S18
	3. Key stop solenoid relay damaged	Check key stop solenoid relay	9-S11
	4. Seat switch damaged	Replace seat switch	9-S17
	5. PTO select lever switch damaged	Check or replace PTO select lever switch	9-S17
	6. PTO lever switch damaged	Check or replace PTO lever switch	9-S17
	7. HST pedal switch damaged	Check or replace HST pedal switch	9-S17
	8. Shuttle shift lever switch damaged	Check or replace shuttle shift lever switch	9-S17
	9. Operator presence controller damaged	Check or replace operator presence controller	9-S17
	10. Wiring harness disconnected or improperly connected (between key stop solenoid relay and key stop solenoid, between key stop solenoid relay between main switch and operator presence controller, between safety switches and operator presence controller and battery positive terminal)	Repair or replace connector and wire harness	9-M1 to 9-M3
	11. Wiring harness disconnected or improperly connected (between operator presence controller and key stop solenoid relay)	Repair or replace connector and wire harness	9-M1 to 9-M3
Engine Stops When HST Pedal or Shuttle Shift Switch is Pushed in Forward or in Reverse	1. OPC switch damaged	1. Check OPC switch	9-S17
		2. Replace seat	10-S33

CHARGING SYSTEM

Symptom	Probable Cause and Checking Procedure	Solution	Reference Page
Charging Lamp Does Not Light when Main Switch is Turned ON	1. Fuse blown (10 A)	Replace wire harness or other	G-40, 9-M1 to 9-M3
	2. Wiring harness disconnected or improperly connected (between main switch AC terminal and panel board, between panel board and dynamo)	Repair or replace connector and other	9-M1 to 9-M3
	3. Alternator damaged	Repair or replace alternator	9-S40
	4. Regulator damaged	Replace regulator	9-M18
Charging Lamp Does Not Go Off When Engine Operates	1. Wiring harness disconnected or improperly connected (between main switch terminal and alternator, between panel board and dynamo)	Repair or replace connector and wire harness	9-M1 to 9-M3
	2. Alternator damaged	Repair or replace alternator	9-S40
	3. Regulator damaged	Replace regulator	9-M18

LIGHTING SYSTEM

Symptom	Probable Cause and Checking Procedure	Solution	Reference Page
Head Light Does Not Light	1. Fuse blown (15 A)	Replace wire harness or other	G-40, 9-M1 to 9-M3
	2. Bulb blown	Replace bulb	G-41
	3. Wiring harness disconnected or improperly connected (between main switch AC terminal and combination switch terminal, between combination switch 1 terminal and headlight)	Repair or replace connector and wire harness	9-M1 to 9-M3
	4. Flasher unit damaged	Repair flasher unit	9-S28
	5. Combination switch damaged	Check or replace Combination switch	9-S22
Tail Light Does Not Light	1. Fuse blown (15 A)	Repair wire harness or other	9-M1 to 9-M3
	2. Bulb blown	Replace bulb	G-41
	3. Wiring harness disconnected or improperly connected (between main switch AC terminal and combination switch terminal, between combination switch T terminal and tail light)	Repair or replace connector and wire harness	9-M1 to 9-M3
	4. Flasher unit damaged	Repair flasher unit	9-S28
Illumination Light Does Not Light	1. Fuse blown (15 A)	Replace fuse	G-40
	2. Bulb blown	Replace bulb	G-41
	3. Wiring harness disconnected or improperly connected (between main switch AC terminal and combination switch terminal, between combination switch T terminal and panel board)	Repair or replace connector and wire harness	9-M1 to 9-M3

Symptom	Probable Cause and Checking Procedure	Solution	Reference Page
Hazard Light (Tail Light) Does Not Light	1. Fuse blown (15 A)	Repair wire harness or other	G-40, 9-M1 to 9-M3
	2. Bulb blown	Replace bulb	G-41
	3. Wiring harness disconnected or improperly connected	Repair or replace connector and wire harness	9-M1 to 9-M3
	4. Flasher unit damaged	Replace flasher unit	9-S28
	5. Hazard switch damaged	Replace hazard switch	9-S26
Hazard Indicator Lamp (Turn Signal Lamp) Does Not Light	1. Bulb blown	Replace bulb	G-41
	2. Wiring harness disconnected or improperly connected	Repair or replace connector and wire harness	9-M1 to 9-M3
Hazard Light (Tail Light) Does Not Flicker	1. Flasher unit damaged	Replace flasher unit	9-S28
Turn Signal Light Does Not Light	1. Fuse blown (10 A)	Repair wire harness or other	G-40, 9-M1 to 9-M3
	2. Bulb blown	Replace bulb	G-41
	3. Wiring harness disconnected or improperly connected	Repair or replace connector and wire harness	9-M1 to 9-M3
	4. Flasher unit damaged	Replace flasher unit	9-S28
	5. Combination switch damaged	Replace combination switch	9-S22
Turn Signal Light Indicator Lamp Does Not Light	1. Bulb blown	Replace bulb	G-41
	2. Wiring harness disconnected or improperly connected (between combination switch R or L terminal and panel board)	Repair or replace connector and wire harness	9-M1 to 9-M3
Turn Signal Light Does Not Flicker	1. Flasher unit damaged	Replace flasher unit	9-S28

EASY CHECKER™

Symptom	Probable Cause and Checking Procedure	Solution	Reference Page
Oil Pressure Lamp Lights Up When Engine Operates	1. Engine oil insufficient	Check engine oil	G-8
	2. Engine oil pressure too low	Solution order 1. Check engine oil pressure	9-S34
		2. Check or change engine oil	G-29
		3. Check or replace oil filter	G-29
		4. Check or replace oil pump	8-M4
	3. Oil pressure switch damaged	Check or replace oil pressure switch	9-S34
	4. Short circuit between oil pressure switch lead and chassis	Repair or replace connector and wire harness	9-M1 to 9-M3
5. Circuit in panel board damaged	Replace meter panel	9-S32	
Oil Pressure Lamp Does Not Light When Main Switch Is Turned On and Engine Is Not Operating	1. Bulb blown	Replace bulb	G-41
	2. Oil pressure switch damaged	Check or replace oil pressure switch	9-S34
	3. Wiring harness disconnected or improperly connected (between panel board and oil pressure switch)	Repair or replace connector and wire harness	9-M1 to 9-M3
	4. Circuit in panel board damaged	Replace meter panel	9-S32

GAUGES

Symptom	Probable Cause and Checking Procedure	Solution	Reference Page
Fuel Gauge Does Not Function	1. Fuel gauge damaged	Replace fuel gauge	9-S37
	2. Fuel level sensor damaged	Replace fuel level sensor	9-S37
	3. Wiring harness disconnected or improperly connected (between panel board and fuel level sensor)	Repair or replace connector and wire harness	9-M1 to 9-M3
	4. Circuit in panel board damaged	Replace meter panel	9-S32
Coolant Temperature Gauge Does Not Function	1. Coolant temperature gauge damaged	Replace coolant temperature gauge	9-S36
	2. Coolant temperature sensor damaged	Replace coolant temperature sensor	9-S36
	3. Wiring harness disconnected or improperly connected (between panel board and coolant temperature sensor)	Repair or replace connector and wire harness	9-M1 to 9-M3
	4. Circuit in panel board damaged	Replace meter panel	9-S32

9Y1210982ELS0097US0

2. SERVICING SPECIFICATIONS

Item		Factory Specification	Allowable Limit
Battery	Voltage	More than 12 V	–
	Potential Difference	Less than 0.1 V	–
Glow Plug	Resistance	Approx. 0.9 Ω	–
Coolant Temperature Sensor (ROPS Model)	Resistance at 130 °C (266 °F)	Approx. 12.2 Ω	–
	at 105 °C (221 °F)	Approx. 23.6 Ω	–
	at 80 °C (176 °F)	Approx. 51.9 Ω	–
	at 50 °C (122 °F)	Approx. 153.9 Ω	–
Coolant Temperature Sensor (CABIN Model)	Resistance at –20 °C (–4 °F)	Approx. 15.0 k Ω	–
	at 20 °C (68 °F)	Approx. 2.45 k Ω	–
	at 80 °C (176 °F)	Approx. 0.318 k Ω	–
Fuel Sensor	Resistance Float at upper-most position	2 to 4 Ω	–
	Float at lower-most position	109 to 111 Ω	–

STARTER

Item		Factory Specification	Allowable Limit
Commutator	O.D.	28.0 mm 1.102 in.	27.0 mm 1.063 in.
	Difference of O.D.'s	Less than 0.02 mm 0.0008 in.	0.05 mm 0.0020 in.
Mica	Undercut	0.60 mm 0.0236 in.	0.20 mm 0.0079 in.
Brush Holder to Holder Support	Resistance	Infinity	–

ALTERNATOR

Item		Factory Specification	Allowable Limit
Non Load Output	Voltage	More than 14 V	–
Stator	Resistance	Less than 1.0 Ω	–
Rotor	Resistance	2.9 Ω	–
Slip Ring	O.D.	14.4 mm 0.567 in.	12.8 mm 0.504 in.
Brush	Length	10.5 mm 0.413 in.	8.4 mm 0.331 in.

9Y1210982ELS0001US0

3. TIGHTENING TORQUES

Tightening torques of screws, bolts and nuts on the table below are especially specified.
(For general use screws, bolts and nuts: See page G-10.)

Item	N·m	kgf·m	lbf·ft
Coolant temperature sensor (ROPS Model)	11.8 to 17.6	1.20 to 1.80	8.68 to 13.0
Coolant temperature sensor (CABIN Model)	Less than 19.6	Less than 2.00	Less than 14.5
Pulley nut	58.3 to 78.9	5.95 to 8.05	43.0 to 58.2

9Y1210982ELS0002US0

4. CHECKING AND ADJUSTING

⚠ CAUTION

- To avoid accidental short circuit, be sure to attach the positive cable to the positive terminal before the negative cable is attached to the negative terminal.
- Never remove the battery cap while the engine operates.
- Keep electrolyte away from eyes, hands and clothes. If you are splattered with it, wash it away completely with water immediately.
- Keep open sparks and flames away from the battery at all times. Hydrogen gas mixed with oxygen becomes very explosive.

■ IMPORTANT

- If the machine is to be operated for a short time without battery (using a slave battery for starting), use additional current (lights) while engine operates and insulate terminal of battery. If this advice is disregarded, damage to alternator and regulator may result.

9Y1210982ELS0003US0

[1] BATTERY

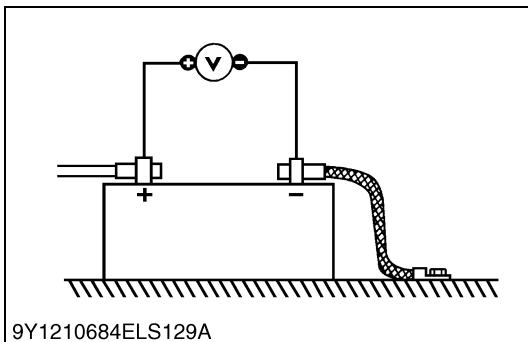

Battery Voltage

1. Stop the engine and turn the main switch off.
2. Connect the COM (-) lead of the voltmeter to the battery's negative terminal post and the (+) lead to the positive terminal post, and measure the battery voltage.
3. If the battery voltage is less than the factory specification, check the battery specific gravity and recharge the battery.

Battery voltage	Factory specification	More than 12 V
-----------------	-----------------------	----------------

9Y1210982ELS0004US0

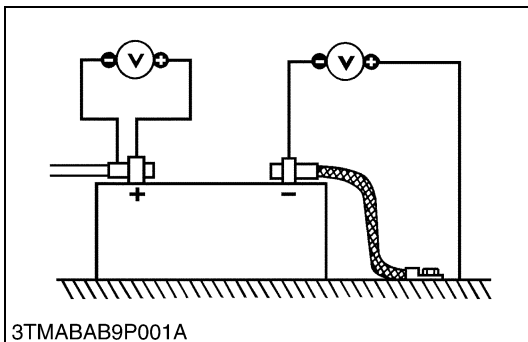

Battery Terminal Connection

1. Turn the main switch on, and turn on the head light.
2. Measure the voltage with a voltmeter across the battery's positive terminal post and the cable terminal, and the voltage across the battery's negative terminal post and the chassis.
3. If the measurement exceeds the factory specification, clean the battery terminal posts and cable clamps, and tighten them firmly.

Potential difference	Factory specification	Less than 0.1 V
----------------------	-----------------------	-----------------

9Y1210982ELS0005US0

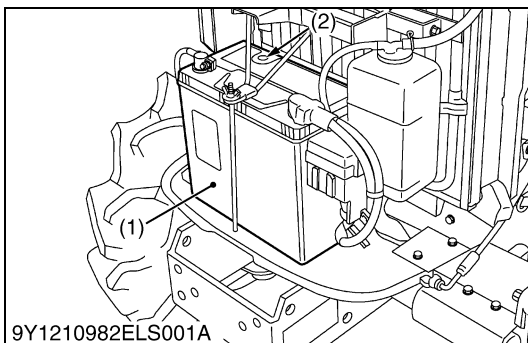

Battery Condition Indicator

1. Check the battery condition by reading the indicator (2).

State of indicator display	
Green	Specific gravity of electrolyte and quality of electrolyte are both in good condition.
Black	Needs charging battery
White	Needs replacing battery

■ IMPORTANT

- The factory installed battery is of non-refillable type. If the indicator turns white, do not charge the battery but replace it with new one.

(1) Battery

(2) Indicator

9Y1210982ELS0006US0

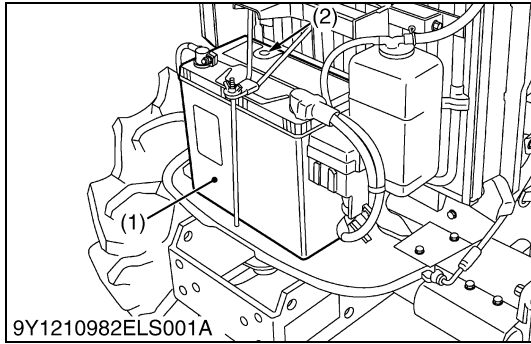

Recharging

CAUTION

- When the battery is being activated, hydrogen and oxygen gases in the battery are extremely explosive. Keep open sparks and flames away from the battery at all times, especially when charging the battery.
- When disconnecting the cable from the battery, start with the negative terminal first. When connecting the cable to the battery, start with the positive terminal first.
- Never check battery charge by placing a metal object across the posts. Use a voltmeter or hydrometer.

1. To slow charge the battery (1), connect the battery positive terminal to the charge positive terminal and the negative to the negative, then recharge in the standard fashion.
2. A boost charge is only for emergencies. It will partially charge the battery at a high rate and in a short time. When using a boost-charged battery, it is necessary to recharge the battery as early as possible. Failure to do this will shorten the battery's service life.
3. The battery is charge if the indicator display turns green from black.
4. When exchanging an old battery for a new one, use battery of equal specification shown in table.

Table

Battery Type	Volt (V)	Capacity at 5 H.R.	Reserve at (min.)	Cold Cranking Amps	Normal Charging Rate (A)
55B24L (S)-MF	12	36	80	430	4.5

(1) Battery

(2) Indicator

9Y1210982ELS0007US0

Directions for Storage

1. When shutting down the tractor for long periods of time, remove the battery from the tractor, store the battery in a well ventilated placed where it is not exposed to direct sunlight.
2. Since the battery self-discharges by approx. 0.5 % per day even in storage, it must be once every two months in cold season.
3. When storing the battery mounted on the tractor, disconnect the ground cable from the battery's negative terminal post.

(Reference)

- Self-discharge Rate

Temperature	Self-discharge rate
30 °C (86 °F)	Approx. 1.0 % per day
20 °C (68 °F)	Approx. 0.5 % per day
10 °C (50 °F)	Approx. 0.25 % per day

9Y1210982ELS0008US0

[2] FUSE

1. When inspecting the circuit line, check the related fuses. For the detail of the fuses, refer to the page G-40.
2. If any of the fuse is blown, replace with a new one of the same capacity.

IMPORTANT

- If a fuse is blown, check the cause and be sure to replace it with a new one of the same capacity.

9Y1210982ELS0009US0

[3] RELAYS

(1) Relays (ROPS Model)

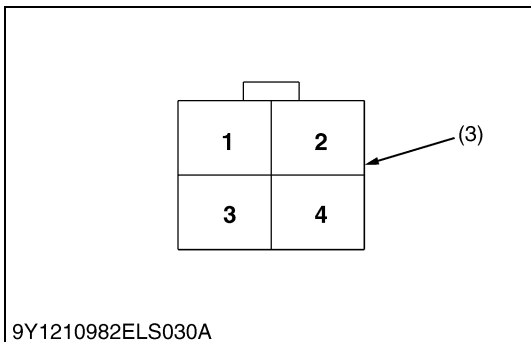
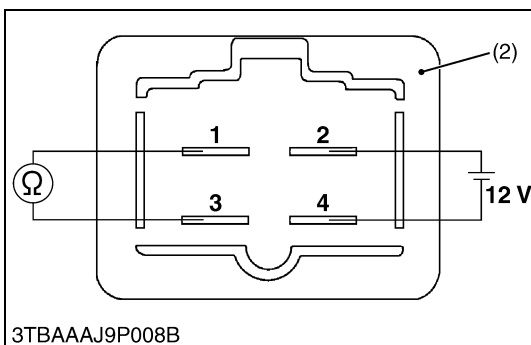
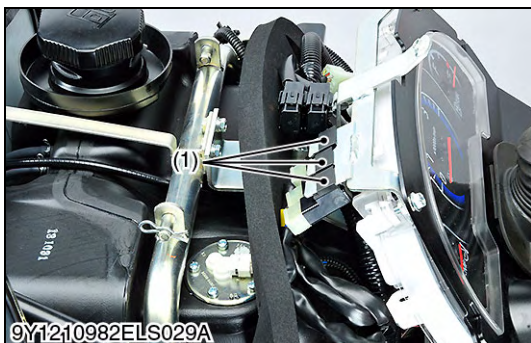

AUX, Head Light 1 and Engine Stop Solenoid (ROPS Model)

1. Remove the relay.
2. Apply battery voltage across 2 terminal and 4 terminal, and check for continuity across 1 terminal and 3 terminal.
3. If 0 Ω is not indicated, renew the relay.

Resistance	1 terminal – 3 terminal	Battery voltage is applied across 2 terminal and 4 terminal	0 Ω
------------	-------------------------	---	-----

■ Color of wiring (To identify the each relay position)

Item	Terminal No.	Color of Wiring
Relay (AUX)	1	Br
	2	R
	3	B
	4	W
Relay (Head Light 1)	1	Br
	2	R
	3	B
	4	L
Relay (Key Stop Solenoid)	1	G
	2	Y
	3	B/W
	4	L

- (1) Relay
- (2) Connector (Relay)

- (3) Connector (Wire Harness)

9Y1210982ELS0010US0

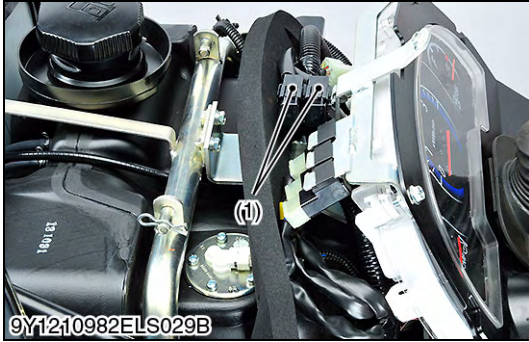

9Y1210982ELS029B

Charge and Head Light 2 (ROPS Model)

1. Remove the relay.
2. Apply battery voltage across 1 terminal and 2 terminal, and check for continuity across 3 terminal and 4 terminal.
3. If 0 Ω is not indicated, renew the relay.

Resistance	3 terminal – 4 terminal	Battery voltage is applied across 1 terminal and 2 terminal	0 Ω
------------	-------------------------	---	-----

■ **Color of wiring (To identify the each relay position)**

Item	Terminal No.	Color of Wiring
Relay (Charge)	1	Br
	2	P/G
	3	Gr
	4	Br
Relay (Head Light 2)	1	Y
	2	B
	3	Sb
	4	W

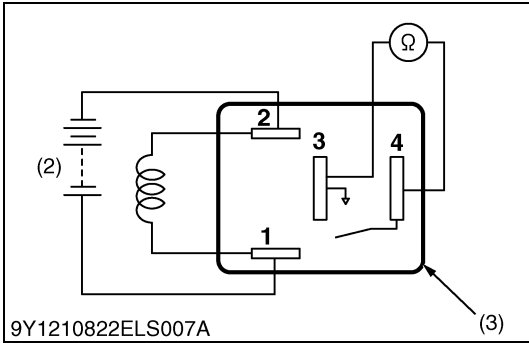

9Y1210822ELS007A

- (1) Relay
- (2) Battery
- (3) Connector (Relay)
- (4) Connector (Wire Harness)

9Y1210982ELS0011US0

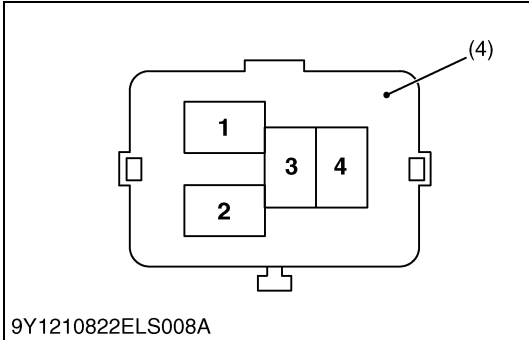

9Y1210822ELS008A

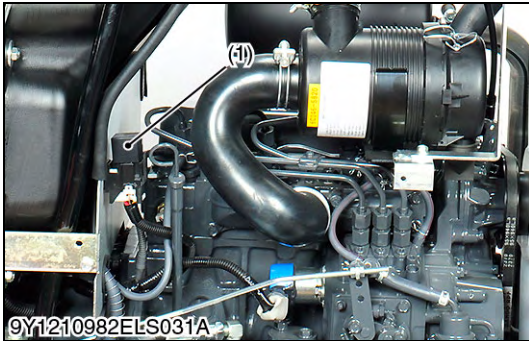

9Y1210982ELS031A

Relay (Glow) (ROPS Model)

1. Remove the relay.
2. Apply battery voltage across 2 terminal and 4 terminal, and check for continuity across 1 terminal and 3 terminal.
3. If 0 Ω is not indicated, renew the relay.

- (1) Relay (Glow)

9Y1210982ELS0012US0

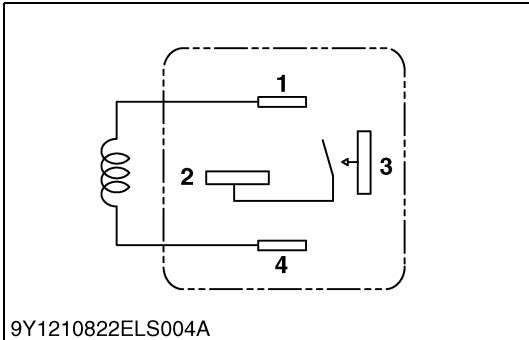

9Y1210822ELS004A

(2) Relays (CABIN Model)

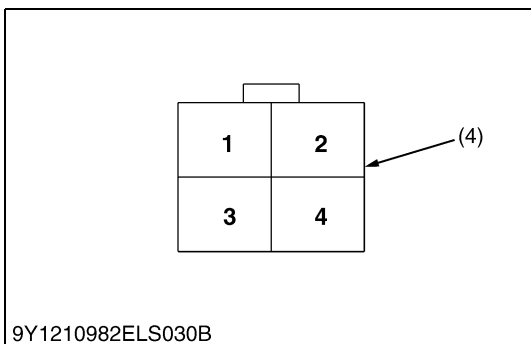
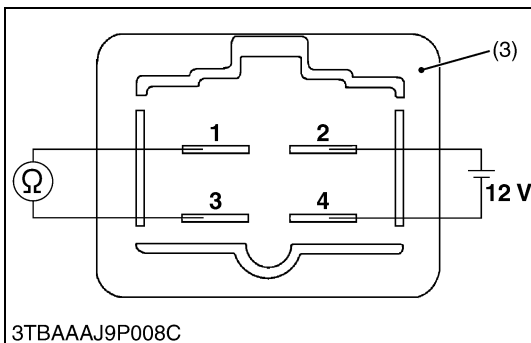
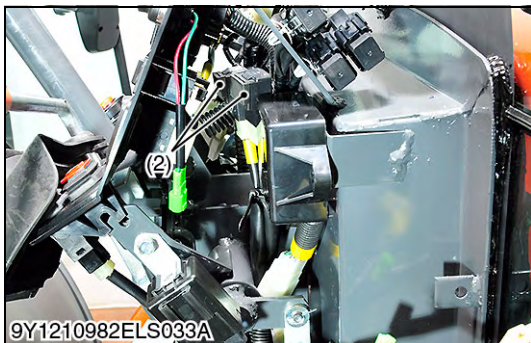
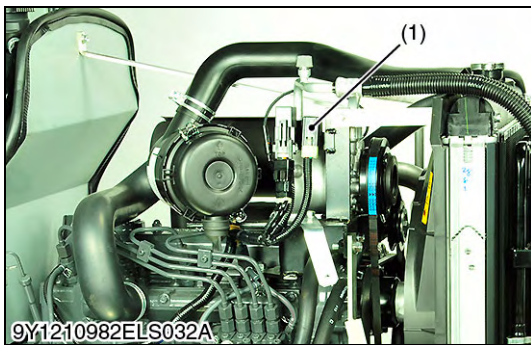

AUX, Head Light 1 and Engine Stop Solenoid (CABIN Model)

1. Remove the relay.
2. Apply battery voltage across 2 terminal and 4 terminal, and check for continuity across 1 terminal and 3 terminal.
3. If 0 Ω is not indicated, renew the relay.

Resistance	1 terminal – 3 terminal	Battery voltage is applied across 2 terminal and 4 terminal	0 Ω
------------	-------------------------	---	-----

■ Color of wiring (To identify the each relay position)

Item	Terminal No.	Color of Wiring
Relay (AUX)	1	Y
	2	R
	3	B
	4	W/B
Relay (Head Light 1)	1	Y
	2	R/Y
	3	B
	4	W
Relay (Key Stop Solenoid)	1	G
	2	R
	3	B
	4	W

- (1) Relay (Key Stop Solenoid)
- (2) Relay (AUX) and Relay (Head Light 1)
- (3) Connector (Relay)
- (4) Connector (Wire Harness)

9Y1210982ELS0013US0

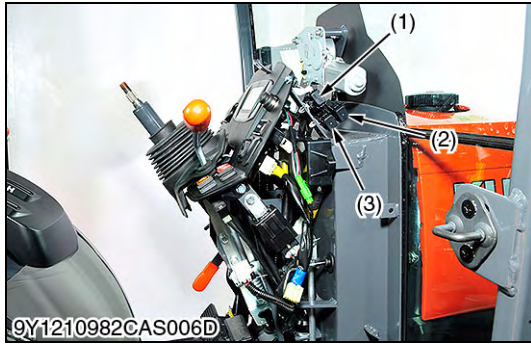

Charge, Head Light 2, Horn, Work Light and Defogger (CABIN Model)

1. Remove the relay.
2. Apply battery voltage across 1 terminal and 2 terminal, and check for continuity across 3 terminal and 4 terminal.
3. If 0 Ω is not indicated, renew the relay.

Resistance	3 terminal – 4 terminal	Battery voltage is applied across 1 terminal and 2 terminal	0 Ω
------------	-------------------------	---	-----

Color of wiring (To identify the each relay position)

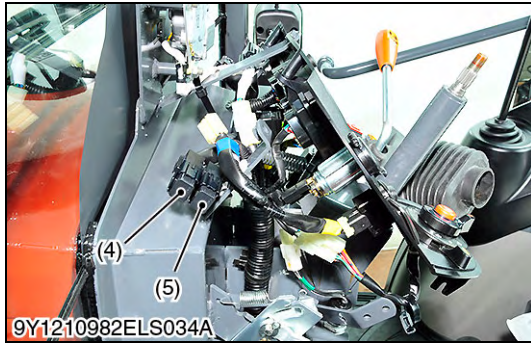

Item	Terminal No.	Color of Wiring
Relay (Charge) (1)	1	Y
	2	L/R
	3	L/R
	4	Y
Relay (Work Light) (2)	1	Y
	2	B
	3	L
	4	Y/L
Relay (Defogger) (3)	1	Gr/R
	2	B
	3	W/R
	4	P
Relay (Horn) (4)	1	W
	2	B
	3	W
	4	L/B
Relay (Head Light 2) (5)	1	P/B
	2	B
	3	Y/B
	4	L/B

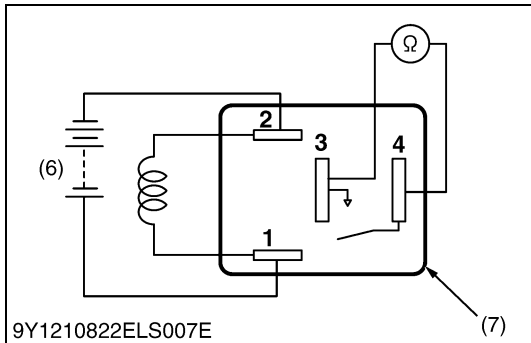

- (1) Relay (Charge)
- (2) Relay (Work Light)
- (3) Relay (Defogger)
- (4) Relay (Horn)
- (5) Relay (Head Light 2)
- (6) Battery
- (7) Connector (Relay)
- (8) Connector (Wire Harness)

9Y1210982ELS0014US0

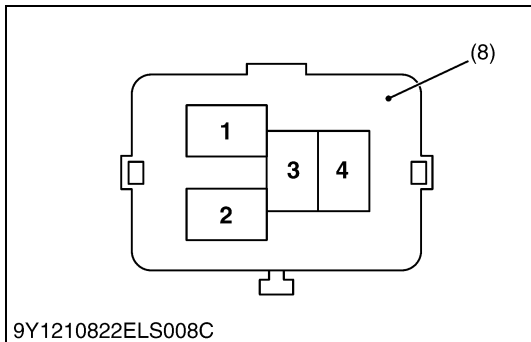

Compressor and Blower (CABIN Model)

- Refer to the page 10-M13 for the relay (compressor) and relay (blower).

9Y1210982ELS0015US0

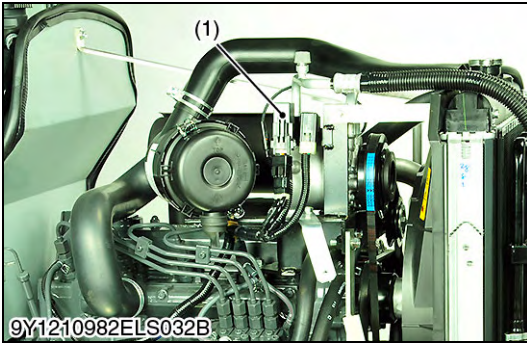

9Y1210982ELS032B

Relay (Glow) (CABIN Model)

1. Remove the relay.
2. Apply battery voltage across **2** terminal and **4** terminal, and check for continuity across **1** terminal and **3** terminal.
3. If 0 Ω is not indicated, renew the relay.

(1) Relay (Glow)

9Y1210982ELS0016US0

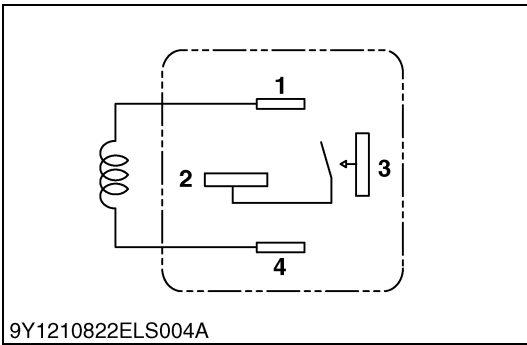

9Y1210822ELS004A

[4] STARTING SYSTEM

(1) Key Switch

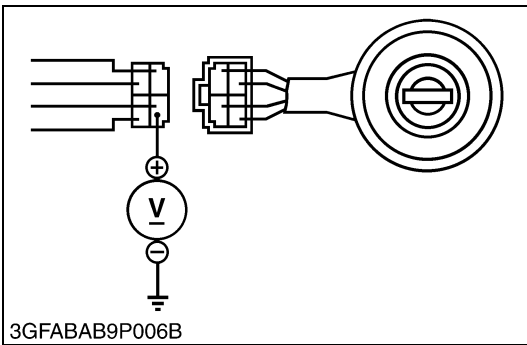

3GFABAB9P006B

Connector Voltage

1. Measure the voltage with a voltmeter across the connector **B** terminal (2) and chassis.
2. If the voltage differs from the battery voltage (11 to 14 V), the wiring harness is damaged.

Voltage	Connector B terminal – Chassis	Approx. battery voltage
---------	---------------------------------------	-------------------------

- | | |
|------------------------|------------------------|
| (1) Main Switch | (4) ST Terminal |
| (2) B Terminal | (5) G Terminal |
| (3) AC Terminal | |

9Y1210982ELS0017US0

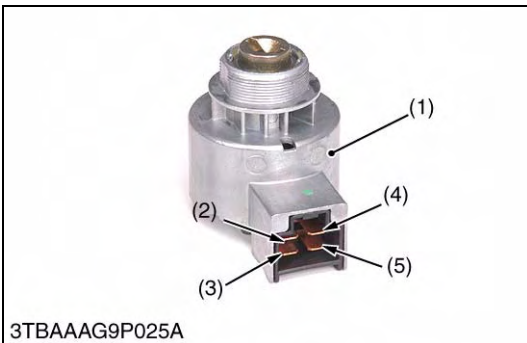

3TBAAAG9P025A

Key Switch Continuity

1) Key Switch Key at "OFF" Position

1. Set the key switch **OFF** position.
2. Measure the resistance with an ohmmeter across the **B** terminal and the **AC** terminal, **B** terminal and **ST** terminal, **B** terminal and **G** terminal.
3. If infinity is not indicated, the contacts of the key switch are damaged.

Resistance	B terminal – AC terminal	Infinity
	B terminal – ST terminal	
	B terminal – G terminal	

9Y1210982ELS0018US0

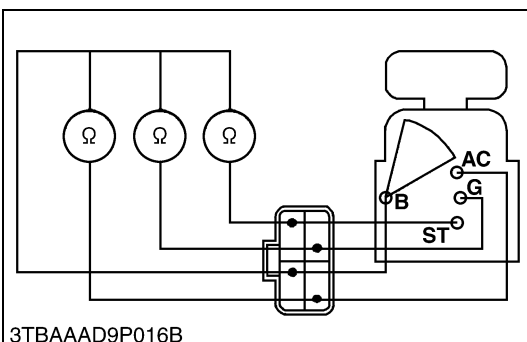

3TBAAAD9P016B

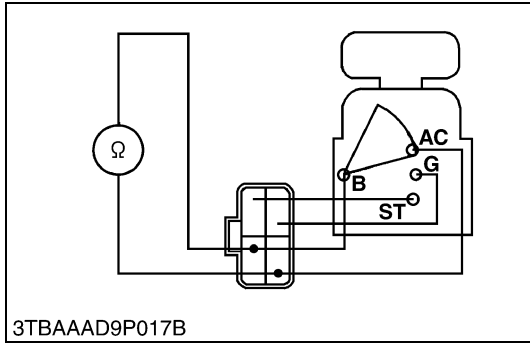

2) Key Switch Key at "ON" Position

1. Set the key switch **ON** position.
2. Measure the resistance with an ohmmeter across the **B** terminal and the **AC** terminal.
3. If 0 Ω is not indicated, the **B - AC** contact of the key switch are damaged.

Resistance	B terminal – AC terminal	0 Ω
------------	--	-----

9Y1210982ELS0019US0

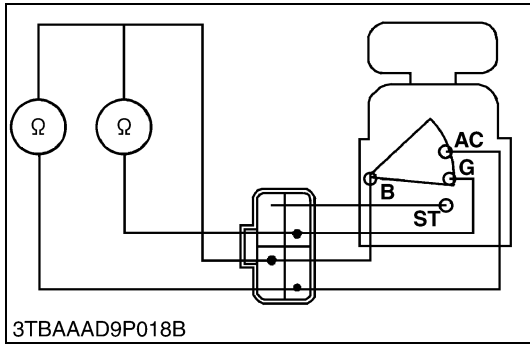

3) Key Switch Key at "PREHEAT" Position

1. Set and hold the key switch key at the **PREHEAT** position.
2. Measure the resistance with an ohmmeter across the **B** terminal and the **G** terminal, and measure the resistance across the **B** terminal and the **AC** terminal.
3. If 0 Ω is not indicated, these contacts of the key switch are damaged.

Resistance	B terminal – G terminal	0 Ω
	B terminal – AC terminal	

9Y1210982ELS0020US0

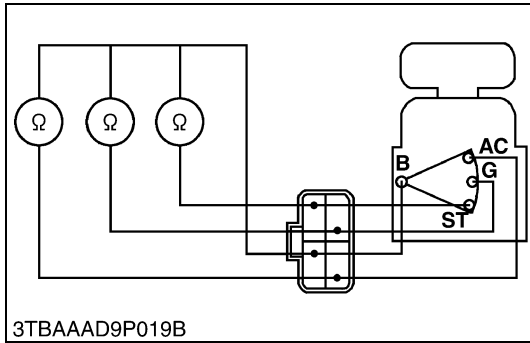

4) Key Switch Key at "START" Position

1. Set and hold the key switch key at the **START** position.
2. Measure the resistance with an ohmmeter across the **B** terminal and the **G** terminal, across the **B** terminal and the **ST** terminal, and across the **B** terminal and the **AC** terminal.
3. If 0 Ω is not indicated, these contacts of the key switch are damaged.

Resistance	B terminal – G terminal	0 Ω
	B terminal – ST terminal	
	B terminal – AC terminal	

Key Position	Terminal			
	B	AC	G	ST
OFF	●			
ON	●	●		
PREHEAT	●	●	●	
START	●	●	●	●

9Y1210982ELS022US

9Y1210982ELS0021US0

(2) Safety Switches

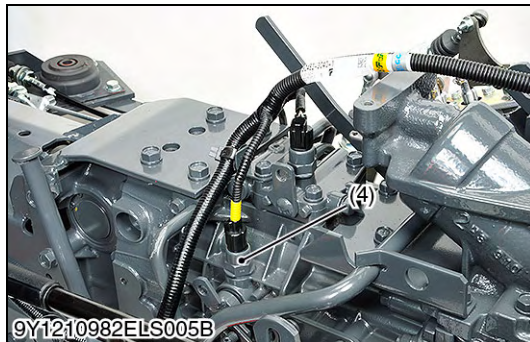
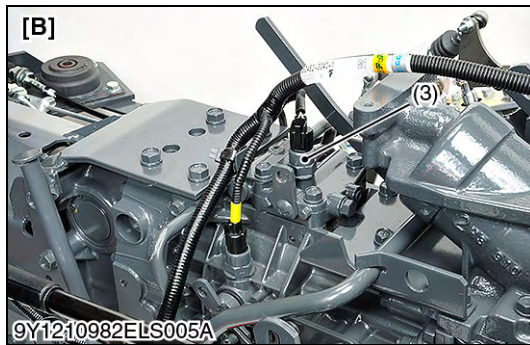
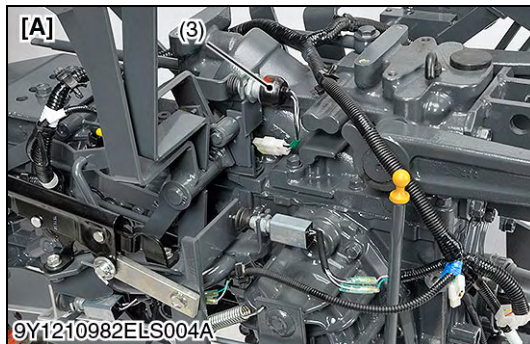
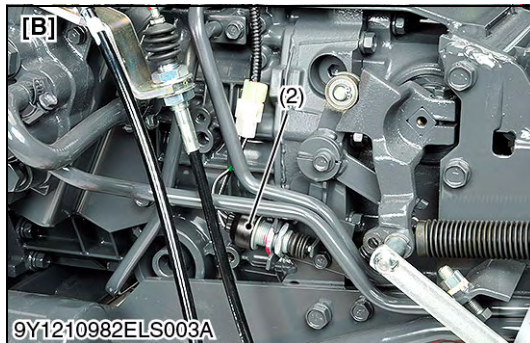
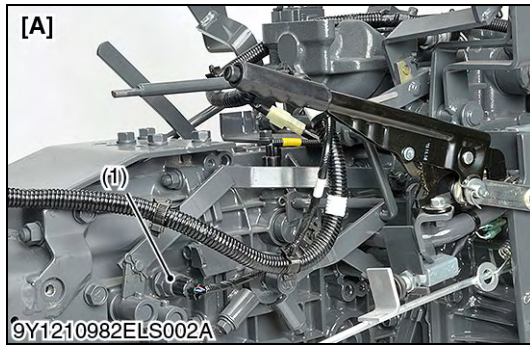

Safety Switch Continuity

1. Disconnect the safety switch leads or couplers.
2. Connect the circuit tester to the safety switch leads.
3. Measure the resistance between leads.
4. If the safety switch is damaged, replace it.

Safety switch	Condition	Resistance
Shuttle shift lever switch (Manual transmission model)	Shuttle shift lever in neutral	0 Ω
	Shuttle shift lever in forward or reverse	Infinity
HST Pedal Switch (HST model)	HST pedal in neutral	0 Ω
	HST pedal in forward or reverse	Infinity
PTO Clutch Lever Switch	PTO clutch lever in disengaged position	0 Ω
	PTO clutch lever in engaged position	Infinity
PTO Select Lever Switch (Only Model With Mid PTO)	PTO select lever in Rear PTO position	0 Ω
	PTO select lever in Rear PTO / Mid PTO or Mid PTO position	Infinity
Seat Switch	Operator on the seat	0 Ω
	Vacant	Infinity
Parking Brake Switch	Parking Lock	0 Ω
	Free	Infinity

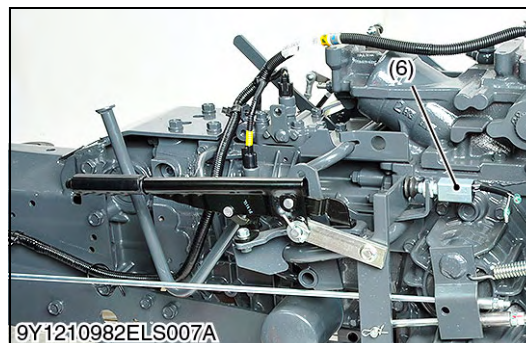
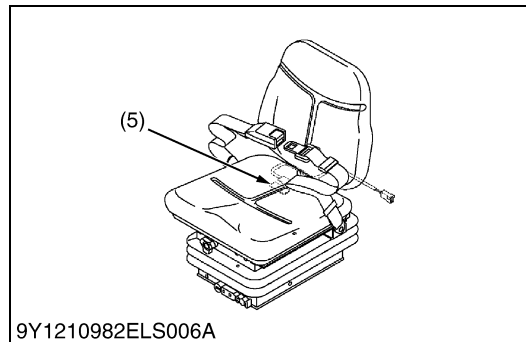

- | | |
|--|--------------------------|
| (1) Shuttle Shift Lever Switch (Manual Transmission Model) | (5) Seat Switch |
| (2) HST Pedal Switch (HST Model) | (6) Parking Brake Switch |
| (3) PTO Clutch Lever Switch | |
| (4) PTO Select Lever Switch (Only Model With Mid PTO) | |

[A] Manual Transmission Model
[B] HST Model

9Y1210982ELS0022US0

(3) OPC Controller

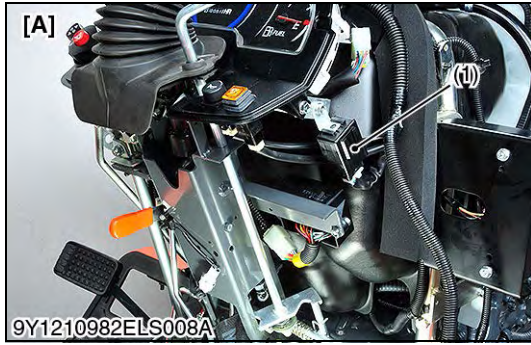

OPC Controller

1. Check the "Engine Starting Conditions" and "Automatic Engine Stop Conditions". (See page 9-M4.)
2. If the tractor does not operate appropriately, check all parts according to the "1.TROUBLESHOOTING" section.
3. If all parts except the OPC controller (1) is not damaged, replace the OPC controller (1).

(1) OPC Controller

[A] ROPS Model

[B] CABIN Model

9Y1210982ELS0023US0

(4) Key Stop Solenoid

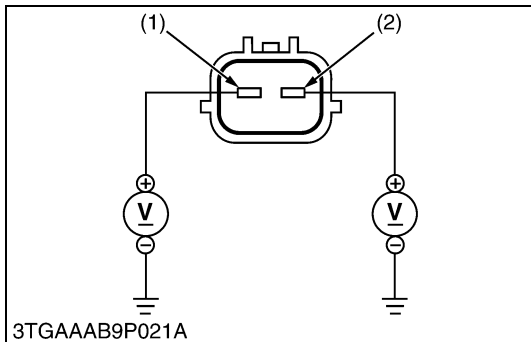

Connector Voltage

1. Disconnect the **2P** connector from key stop solenoid.
2. Turn the main switch key to the "**ON**" position.
3. Measure the voltage with voltmeter between the terminal **1**, terminal **2** of wiring harness side and body.
4. If the voltage differs from the battery voltage, the wiring harness or main switch is damaged.

Voltage	Terminal 1 – Body	Approx. battery voltage
	Terminal 2 – Body	Approx. battery voltage

(1) Terminal 2

(2) Terminal 1

9Y1210982ELS0024US0

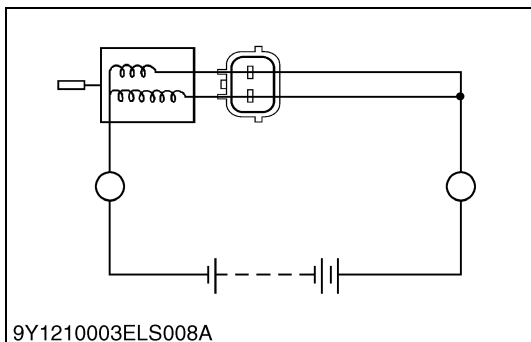

Key Stop Solenoid Test

1. Disconnect the lead from the engine stop solenoid after turning the main switch off.
2. Connect jumper leads from the battery positive terminal to the key stop solenoid terminal **1** and **2**, then from the battery negative terminal to the key stop solenoid body.
3. If the solenoid plunger is not attracted, the key stop solenoid is damaged.

(1) Battery

9Y1210982ELS0025US0

(5) Starter

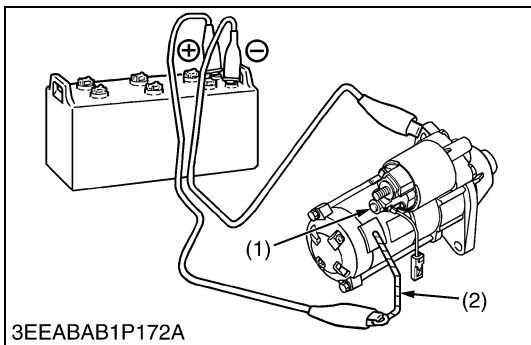

Motor Test



CAUTION

- **Secure the starter to prevent it from jumping up and down while testing the motor.**
1. Disconnect the battery negative cable from the battery.
 2. Disconnect the battery positive cable and the leads from the starter **B** terminal.
 3. Remove the starter from the engine.
 4. Disconnect the connecting lead (2) from the starter **C** terminal (1).
 5. Connect a jumper lead from the connecting lead (2) to the battery positive terminal post.
 6. Connect a jumper lead momentarily between the starter motor housing and the battery negative terminal post.
 7. If the motor does not operate, check the motor.

(1) **C** Terminal

(2) Connecting Lead

9Y1210982ELS0026US0

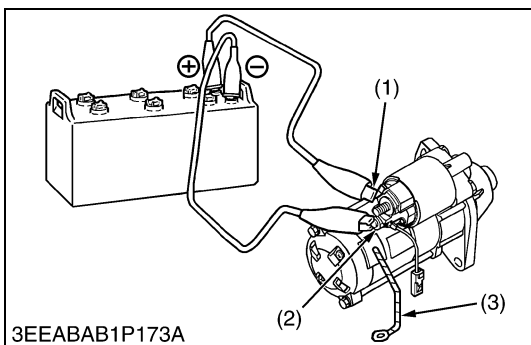

Magnetic Switch Test

1. Disconnect the battery negative cable from the battery.
2. Disconnect the battery positive cable and the leads from the starter **B** terminal.
3. Remove the starter from the engine.
4. Disconnect the connecting lead (3) from the starter **C** terminal (2).
5. Connect a jumper lead from the starter **S** terminal (2) to the battery positive terminal post.
6. Connect a jumper lead momentarily between the starter **C** terminal (2) and the battery negative terminal post.
7. If the pinion gear does not pop out, check the magnetic switch.

NOTE

- **This test should take no longer than 3 to 5 seconds at a time.**

(1) **S** Terminal

(3) Connecting Lead

(2) **C** Terminal

9Y1210982ELS0027US0

(6) Glow Plug

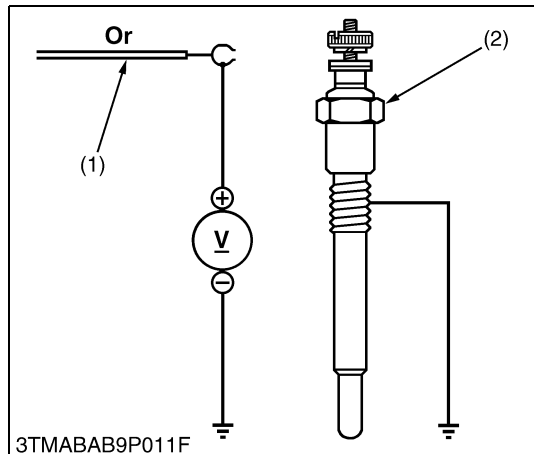

Lead Terminal Voltage

1. Disconnect the wiring lead (1) from the glow plug (2) after turning the main switch **OFF**.
2. Turn the main switch key to the **PREHEAT** position, and measure the voltage between the lead terminal and the chassis.
3. Turn the main switch key to the **START** position, and measure the voltage with a voltmeter between the lead terminal and the chassis.
4. If the voltage at either position differs from the battery voltage, the wiring harness or main switch is damaged.

Voltage (Lead terminal - Chassis)	Main switch key at PREHEAT	Approx. battery voltage
	Main switch key at START	

(1) Wiring Lead

(2) Glow Plug

9Y1210982ELS0028US0

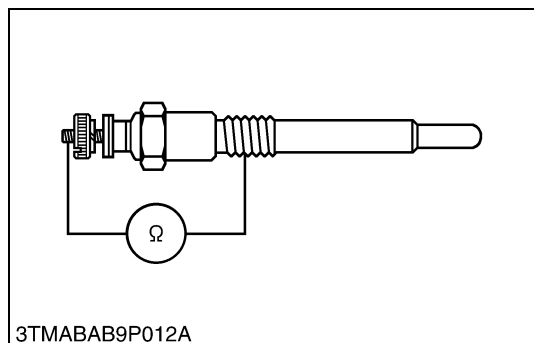

Glow Plug Continuity

1. Disconnect the leads from the glow plugs.
2. Measure the resistance with an ohmmeter between the glow plug terminal and chassis.
3. If 0 Ω is indicated, the screw at the tip of the glow plug and the housing are short-circuited.
4. If the factory specification is not indicated, the glow plug is damaged.

Glow plug resistance	Factory specification	Approx. 0.9 Ω
----------------------	-----------------------	---------------

9Y1210982ELS0029US0

[5] CHARGING SYSTEM

(1) Alternator

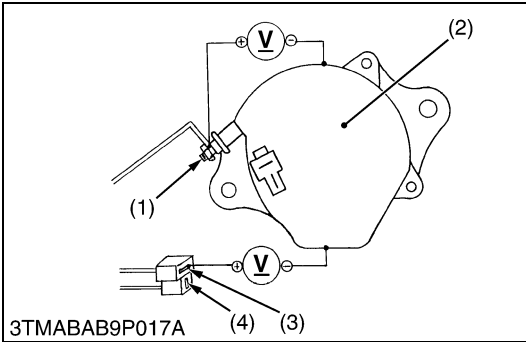

Connector Voltage

1. Turn the main switch **OFF**. Measure the voltage between the **B** terminal (1) and the chassis.
2. Turn the main switch **ON**. Measure the voltage between the **IG** terminal (3) and the chassis.

Voltage (Main switch at OFF)	B terminal – Chassis	Approx. battery voltage
Voltage (Main switch at ON)	B terminal – Chassis	Approx. battery voltage

- (1) **B** Terminal (3) **IG** Terminal
 (2) Alternator (4) **L** Terminal

9Y1210982ELS0030US0

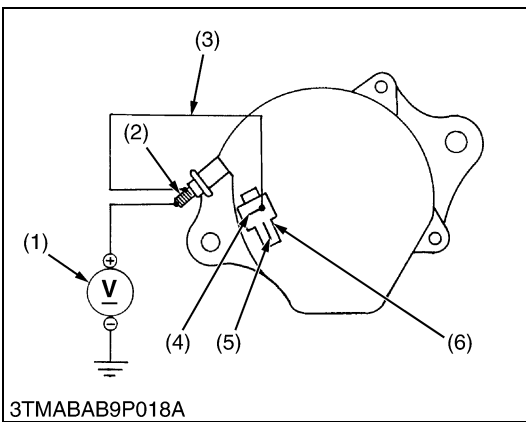

No-Load Test

1. Connect the **2P** connector (6) to previous positions of the alternator after turning the main switch **OFF**.
2. Connect the jumper lead (3) between **IG** terminal (4) and **B** terminal (2).
3. Start the engine and then set at idling speed.
4. Disconnect the negative cable from the battery.
5. Measure the voltage between the **B** terminal (2) and the chassis.
6. If the measurement is less than the factory specifications, disassemble the alternator and check the IC regulator.

Voltage	Factory specification	More than 14 V
---------	-----------------------	----------------

(Reference)

- Once the engine has started, the alternator temperature rises quickly up to an ambient temperature of 70 to 90 °C (158 to 194 °F). As the temperature goes higher than 50 °C (122 °F), the alternator voltage slowly drops; at higher than 100 °C (212 °F), it drops by about 1 V.

- (1) Voltmeter (4) **IG** Terminal
 (2) **B** Terminal (5) **L** Terminal
 (3) Jumper Lead (6) **2P** Connector

9Y1210982ELS0031US0

[6] LIGHTING SYSTEM

(1) Combination Switch (ROPS Model)



Combination Switch (ROPS Model)

1. Remove the steering wheel and panel lower cover.
2. Disconnect the combination switch connector.
3. Remove the combination switch (1) and perform the following checks 1) to 8).

(1) Combination Switch

9Y1210982ELS0032US0

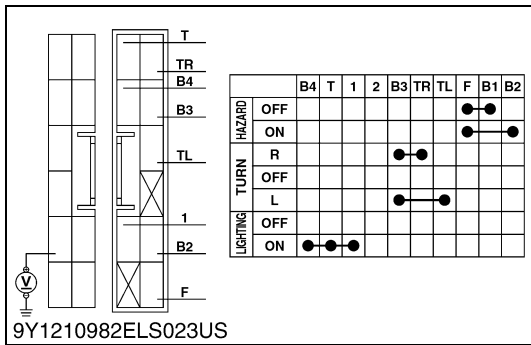

1) Connector Voltage

1. Measure the voltage with a voltmeter across the connector **B2**, **B4**, **TL**, **TR** terminal and chassis when the main switch is **ON** position.
2. If the voltage differs from the battery voltage, the wiring harness and main switch is damaged.

Voltage	Main switch at ON position	B2 terminal – Chassis	Battery voltage
		B4 terminal – Chassis	
		TL terminal – Chassis	
		TR terminal – Chassis	

9Y1210982ELS0033US0

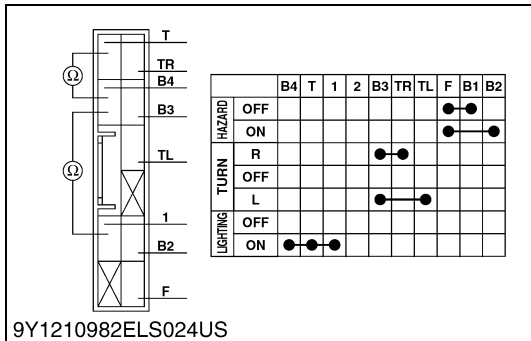

2) Head Light Switch Continuity When Setting Switch at OFF Position

1. Set the light switch to the **OFF** position.
2. Measure the resistance with an ohmmeter across the **B4** terminal to the **T** terminal, the **B4** terminal to the terminal **1**.
3. If infinity is not indicated, the head light switch is damaged.

Resistance (Switch at OFF position)	B4 terminal – T terminal	Infinity
	B4 terminal – 1 terminal	

9Y1210982ELS0034US0

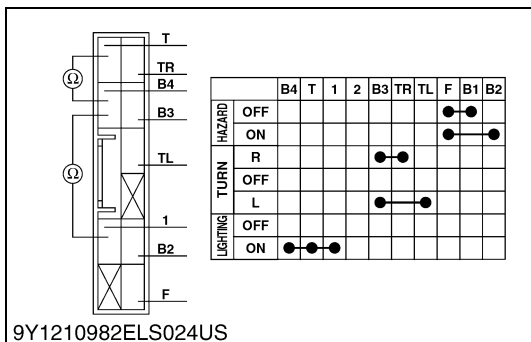

3) Head Light Switch Continuity When Setting Switch at ON Position

1. Set the light switch to the **ON** position.
2. Measure the resistance with an ohmmeter across the **B4** terminal to the **T** terminal and the **B4** terminal to the terminal **1**.
3. If 0 Ω is not indicated, the head light switch is damaged.

Resistance (Switch at ON position)	B4 terminal – T terminal	0 Ω
	B4 terminal – 1 terminal	

9Y1210982ELS0035US0

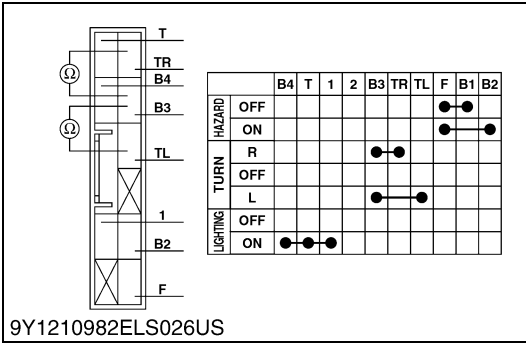

4) Turn Signal Light Switch Continuity When Setting Switch Knob OFF Position

1. Set the turn signal light switch to the **OFF** position.
2. Measure the resistance with an ohmmeter across the **B3** terminal and **TL** terminal, the **B3** terminal and **TR** terminal.
3. If infinity is not indicated, the combination switch is damaged.

Resistance (Switch knob at OFF position)	B3 terminal – TL terminal	Infinity
	B3 terminal – TR terminal	

9Y1210982ELS0036US0

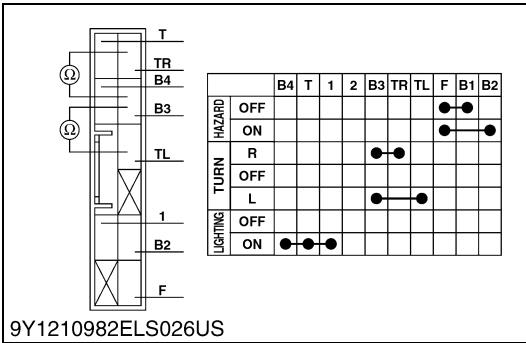

5) Turn Signal Light Switch Continuity When Setting Switch Knob at L Position

1. Set the turn signal light switch to the **L** position.
2. Measure the resistance with an ohmmeter across the **B3** terminal and **TL** terminal.
3. If 0 Ω is not indicated, the combination switch is damaged.

Resistance (Switch knob at left position)	B3 terminal – TL terminal	0 Ω
	B3 terminal – TR terminal	Infinity

9Y1210982ELS0037US0

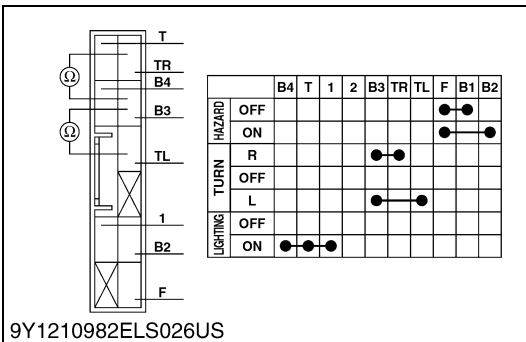

6) Turn Signal Light Switch Continuity When Setting Switch Knob at R Position

1. Set the turn signal light switch to the **R** position.
2. Measure the resistance with an ohmmeter across the **B3** terminal and **TR** terminal.
3. If 0 Ω is not indicated, the combination switch is damaged.

Resistance (Switch knob at right position)	B3 terminal – TR terminal	0 Ω
	B3 terminal – TL terminal	Infinity

9Y1210982ELS0038US0

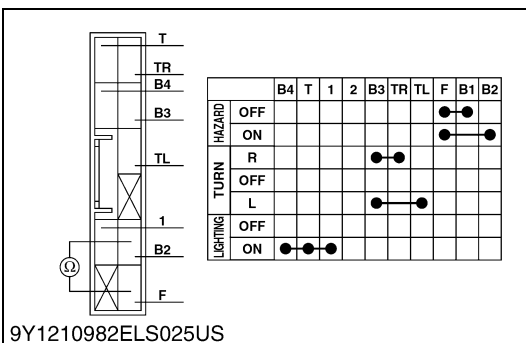

7) Hazard Switch Continuity when Not Pushing Button

1. Set the hazard switch to the **OFF** position.
2. Measure the resistance with an ohmmeter across the **B2** terminal and the **F** terminal.
3. If infinity is not indicated, the combination switch is damaged.

Resistance (Hazard switch at OFF position)	B2 terminal – F terminal	Infinity
--	--	----------

9Y1210982ELS0039US0

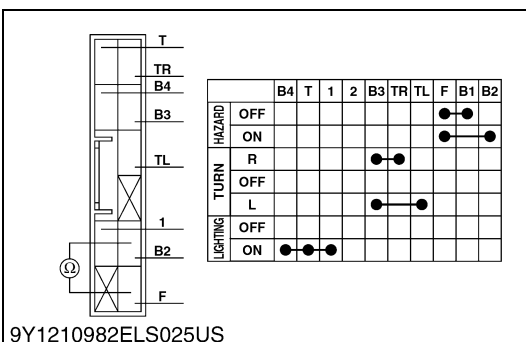

8) Hazard Switch at "ON" Position

1. Set the hazard switch to the **ON** position.
2. Measure the resistance with an ohmmeter across the **B2** terminal and the **F** terminal.
3. If 0 Ω is not indicated, the combination switch is damaged.

Resistance (Hazard switch at ON position)	B2 terminal – F terminal	0 Ω
---	--	-----

9Y1210982ELS0040US0

(2) Combination Switch (CABIN Model)



Combination Switch (CABIN Model)

1. Remove the steering wheel and panel lower cover.
2. Disconnect the combination switch connector.
3. Remove the combination switch (1) and perform the following checks 1) to 8).

(1) Combination Switch

9Y1210982ELS0041US0

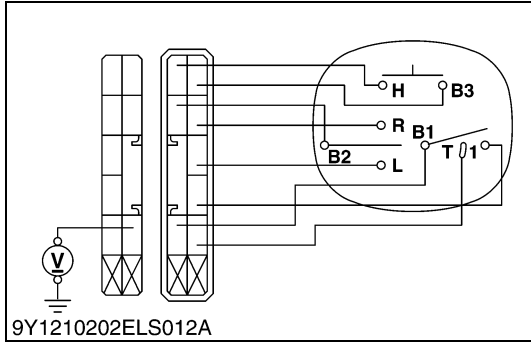

1) Connector Voltage

1. Measure the voltage with a voltmeter across the connector **B1**, **B3**, **L**, **R** terminal and chassis when the main switch is "ON" position.
2. If the voltage differs from the battery voltage, the wiring harness and main switch is damaged.

Voltage	Main switch at "ON" position	B1 terminal – Chassis	Battery voltage
		B3 terminal – Chassis	
		L terminal – Chassis	
		R terminal – Chassis	

9Y1210982ELS0042US0

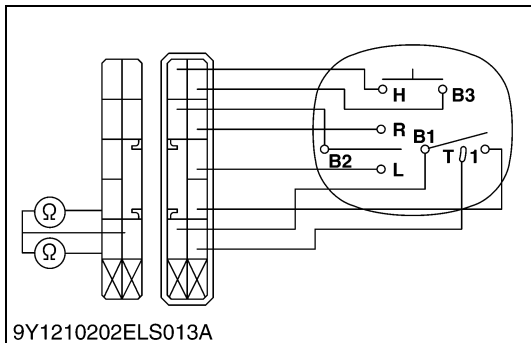

2) Head Light Switch Continuity when Setting Switch at OFF Position

1. Set the light switch to the OFF position.
2. Measure the resistance with an ohmmeter across the **B1** terminal to the **T** terminal, the **B1** terminal to the terminal **1**.
3. If infinity is not indicated, the head light switch is damaged.

Resistance (Switch at OFF position)	B1 terminal – T terminal	Infinity
	B1 terminal – 1 terminal	

9Y1210982ELS0043US0

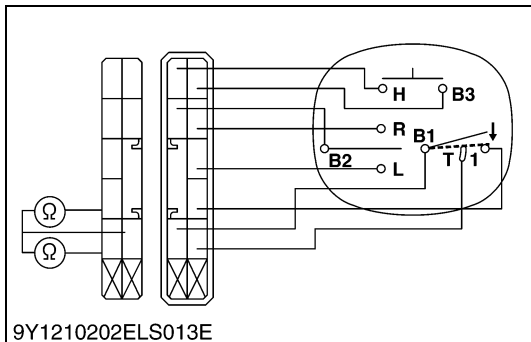

3) Head Light Switch Continuity when Setting Switch at ON Position

1. Set the light switch to the ON position.
2. Measure the resistance with an ohmmeter across the **B1** terminal to the **T** terminal and the **B1** terminal to the terminal **1**.
3. If 0 Ω is not indicated, the head light switch is damaged.

Resistance (Switch at ON position)	B1 terminal – T terminal	0 Ω
	B1 terminal – 1 terminal	

9Y1210982ELS0044US0

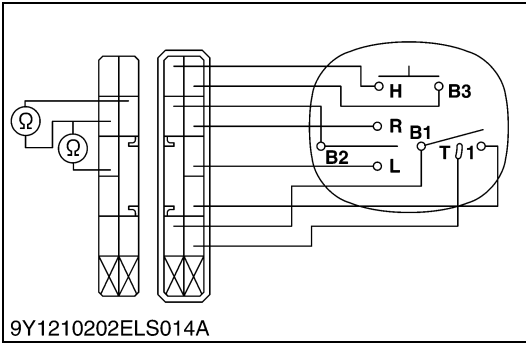

4) Turn Signal Light Switch Continuity When Setting Switch Knob OFF Position

1. Set the turn signal light switch to the **OFF** position.
2. Measure the resistance with an ohmmeter across the **B2** terminal and **L** terminal, the **B2** terminal and **R** terminal.
3. If infinity is not indicated, the combination switch is damaged.

Resistance (Switch knob at OFF position)	B2 terminal – L terminal	Infinity
	B2 terminal – R terminal	

9Y1210982ELS0045US0

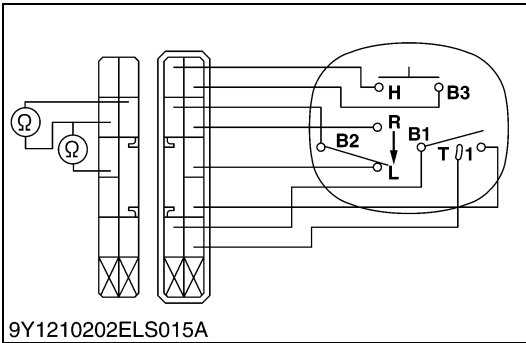

5) Turn Signal Light Switch Continuity When Setting Switch Knob at L Position

1. Set the turn signal light switch to the **L** position.
2. Measure the resistance with an ohmmeter across the **B2** terminal and **L** terminal.
3. If 0 Ω is not indicated, the combination switch is damaged.

Resistance (Switch knob at L position)	B2 terminal – L terminal	0 Ω
	B2 terminal – R terminal	Infinity

9Y1210982ELS0046US0

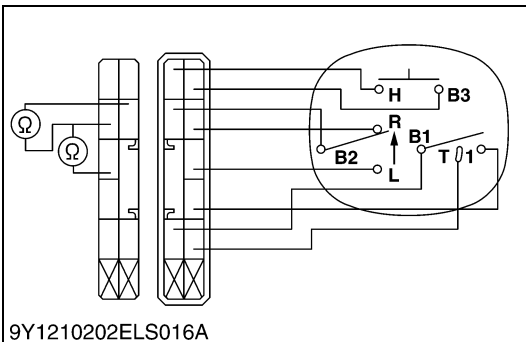

6) Turn Signal Light Switch Continuity When Setting Switch Knob at R Position

1. Set the turn signal light switch to the **R** position.
2. Measure the resistance with an ohmmeter across the **B2** terminal and **R** terminal.
3. If 0 Ω is not indicated, the combination switch is damaged.

Resistance (Switch knob at R position)	B2 terminal – L terminal	0 Ω
	B2 terminal – R terminal	Infinity

9Y1210982ELS0047US0

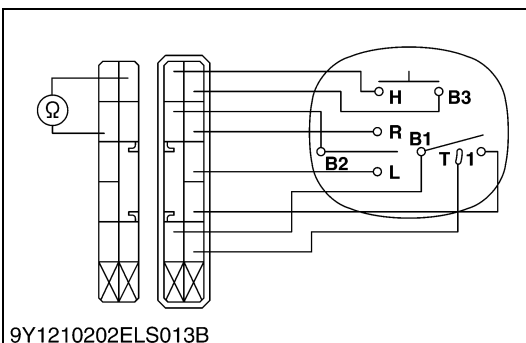

7) Horn Button Continuity when Not Pushing Button

1. Set the horn button to the **OFF** position.
2. Measure the resistance with an ohmmeter across the **B3** terminal and the **H** terminal.
3. If infinity is not indicated, the combination switch is damaged.

Resistance (Horn button at OFF position)	B3 terminal – H terminal	Infinity
--	--	----------

9Y1210982ELS0048US0

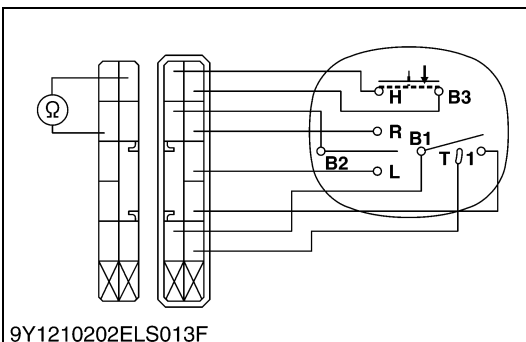

8) Horn Button at "ON" Position

1. Set the horn button to the **ON** position.
2. Measure the resistance with an ohmmeter across the **B3** terminal and the **H** terminal.
3. If infinity is not indicated, the combination switch is damaged.

Resistance (Horn button at ON position)	B3 terminal – H terminal	0 Ω
---	--	-----

9Y1210982ELS0049US0

(3) Hazard Switch (Cabin Model Only)



■ **NOTE**

- Refer to the page 9-M25 for the hazard switch (CABIN model).

(1) Hazard Switch

9Y1210982ELS0050US0

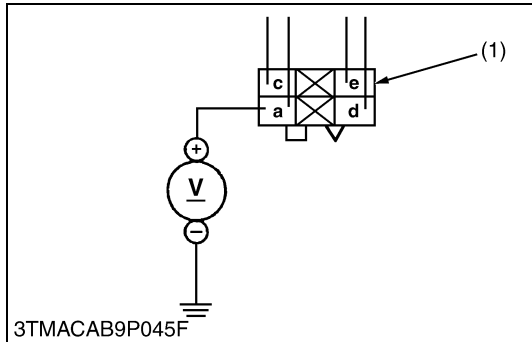

Connector Voltage

1. Connect the battery negative code, then measure the voltage with a voltmeter across the a terminal and chassis.
2. If the voltage differ from the battery voltage, the wiring harness is damaged.

Voltage	a terminal – Chassis	Approx. battery voltage
---------	----------------------	-------------------------

(1) 4P Connector (for Hazard Switch)

9Y1210982ELS0051US0

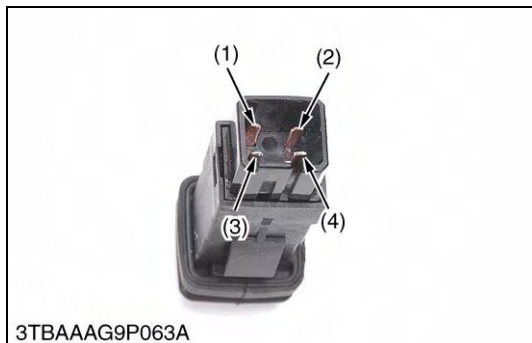

Hazard Switch Continuity

1. Measure the resistance with ohmmeter across the a terminal (1) and c terminal (3), and across the d terminal (2) and e terminal (4).
2. If the measurement is not following below, the hazard switch or the bulb are damaged.

Resistance (Switch at OFF)	a terminal – c terminal	Infinity
Resistance (Switch at ON)	a terminal – c terminal	0 Ω
Resistance (Bulb)	d terminal – e terminal	Approx. 13 Ω

- (1) a Terminal
 (2) d Terminal
 (3) c Terminal

- (4) e Terminal
 (5) Bulb

9Y1210982ELS0052US0

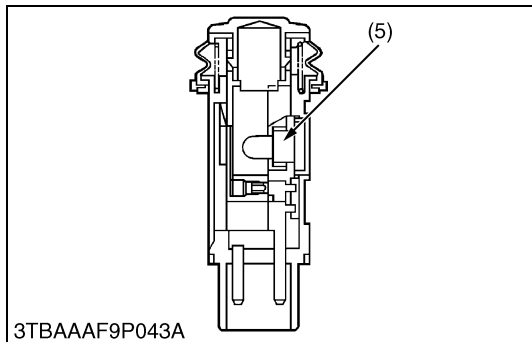

(4) Beacon Switch

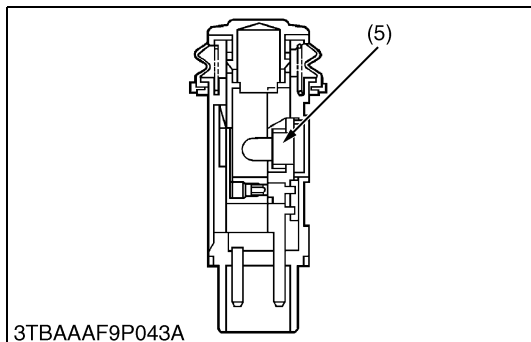
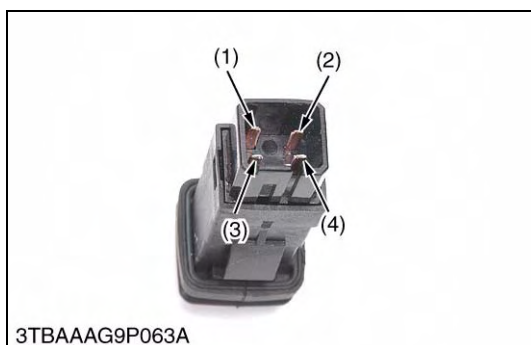
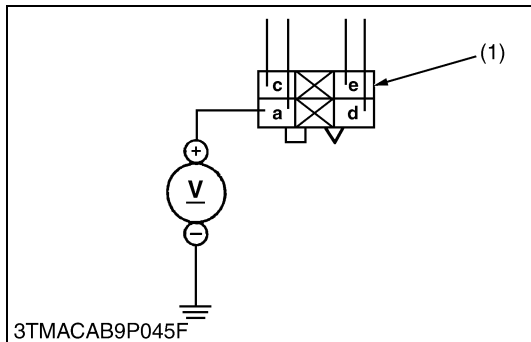

(1) Beacon Switch

[A] ROPS Model
[B] CABIN Model

9Y1210982ELS0053US0

Connector Voltage

1. Connect the battery negative code, then measure the voltage with a voltmeter across the **a** terminal and chassis.
2. If the voltage differ from the battery voltage, the wiring harness is damaged.

Voltage	a terminal – Chassis	Approx. battery voltage
---------	-----------------------------	-------------------------

(1) **4P** Connector (for Beacon Switch)

9Y1210982ELS0054US0

Beacon Switch Continuity

1. Measure the resistance with ohmmeter across the **a** terminal (1) and **c** terminal (3), and across the **d** terminal (2) and **e** terminal (4).
2. If the measurement is not following below, the beacon switch or the bulb are damaged.

Resistance (Switch at OFF)	a terminal – c terminal	Infinity
Resistance (Switch at ON)	a terminal – c terminal	0 Ω
Resistance (Bulb)	d terminal – e terminal	Approx. 13 Ω

- (1) **a** Terminal
- (2) **d** Terminal
- (3) **c** Terminal

- (4) **e** Terminal
- (5) Bulb

9Y1210982ELS0055US0

(5) Flasher Unit

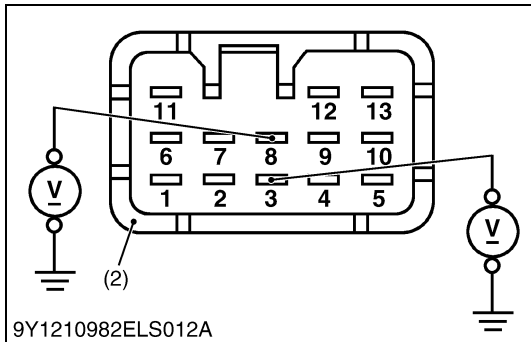
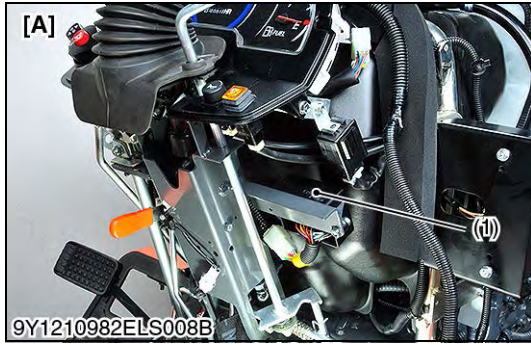

Supply Voltage to Flasher Unit

1. Disconnect the connector from the flasher unit.
2. Measure the voltage between the terminal 7, 8 and chassis.
3. If the voltage differ from the battery voltage, the wiring harness is damaged.

Voltage	Key switch at "ON"	Terminal 8 – Chassis	Approx. battery voltage
		Terminal 7 – Chassis	Approx. battery voltage

(Reference)

1	Turn signal switch (R)
2	Blank
3	To battery direct (beacon)
4	Turn signal switch (L)
5	Hazard switch
6	Turn signal (R)
7	ACC
8	Battery
9	Turn signal (L)
10	Beacon switch
11	Beacon outlet
12	GND
13	Trailer indicator

1. Set the hazard switch to the **ON** position, and make sure the hazard light gives 85 to 95 flashers for a minute.
2. Set the key switch to the **ON** position and move the turn signal switch to the left. Make sure the left-hand light gives flashes. Then move the turn signal switch to the right and make sure the right-hand light gives flashes. Make sure the same actions as above result.
3. If both the hazard switch and the turn signal switch function but the above actions do not take place, replace the flasher unit with new one.

- (1) Flasher Unit
- (2) Flasher Unit 13P Coupler

1 to 13:Terminals
[A] ROPS Model
[B] CABIN Model

9Y1210982ELS0056US0

(6) Brake Lamp Switch

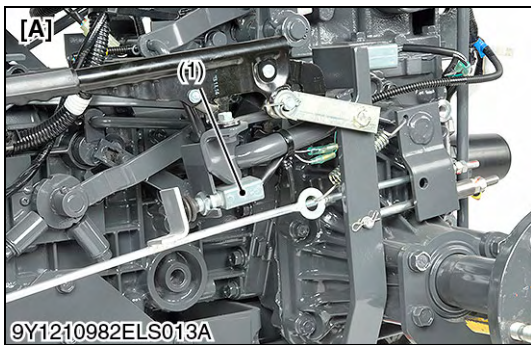

Brake Lamp Switch Continuity

1. Disconnect the switch leads or coupler.
2. Connect the circuit tester to the switch leads.
3. Measure the resistance between leads.
4. If the switch is damaged, replace it.

Brake lamp switch	When brake lamp switch is not pushed	Infinity
	When brake lamp switch is pushed	0 Ω

(1) Parking Brake Switch

[A] ROPS Model

[B] CABIN Model

9Y1210982ELS0057US0

(7) Work Light Switch (CABIN Model Only)



Work Light Switch

1. Remove the meter panel lower cover and disconnect the **6P** connector from work light switch (1).
2. Remove the work light switch (1).
3. Perform the following check.

(1) Work Light Switch

9Y1210982ELS0058US0

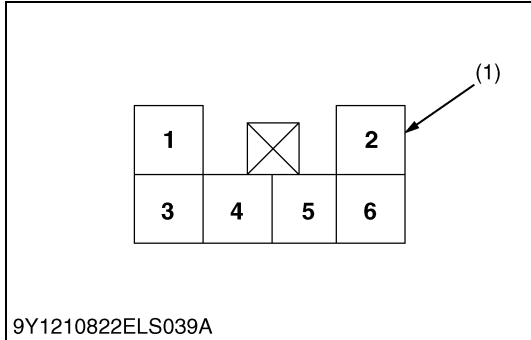

1) Connector Voltage

1. Turn the key switch "ON" position.
2. Measure the voltage with a voltmeter across the terminals shown in the table below.
3. If the reference value as shown in the table below is not indicated, check the relating electric circuit.

Voltage	Key switch at "ON"	Terminal 5 – Chassis	Approx. battery voltage
	Key switch and head light switch at "ON"	Terminal 2 – Chassis	Approx. battery voltage

(1) Connector (Harness Side)

9Y1210982ELS0059US0

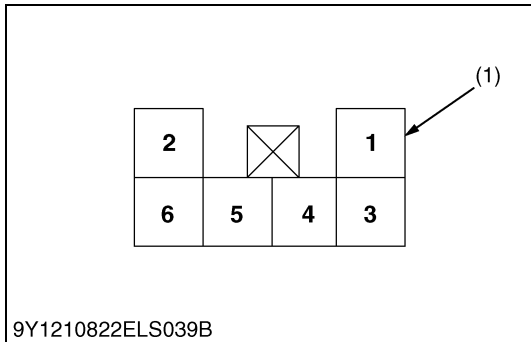

2) Switch Continuity

1. Check the continuity across the terminals shown in the table below.
2. If the continuity specified below is not indicated, the switch is damaged.

Position	Terminal				
	5	6	3	1	2
OFF				⊖	
ON	●	●	●	⊖	

9Y1210982ELS027US

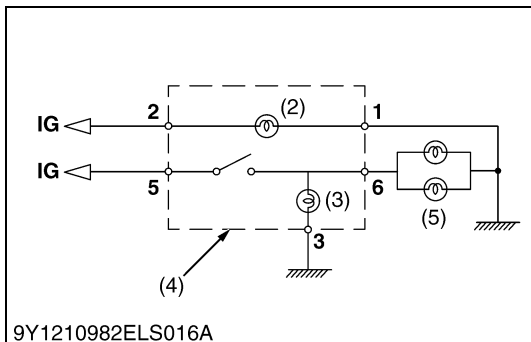

(1) Connector (Switch Side)

(2) Night Light

(3) Indicator

(4) Work Light Switch

(5) Work Light

9Y1210982ELS0060US0

(8) Dome Light (CABIN Model Only)

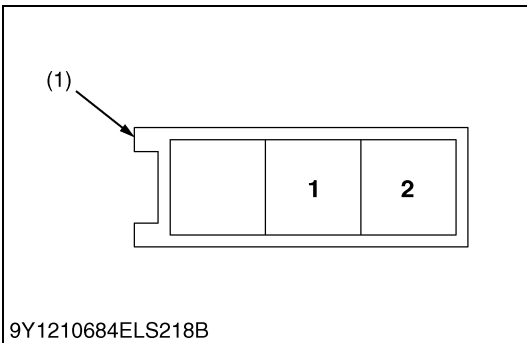
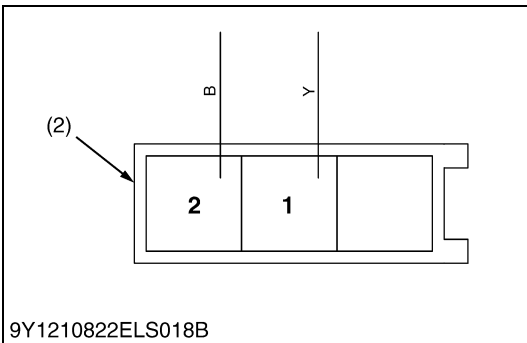
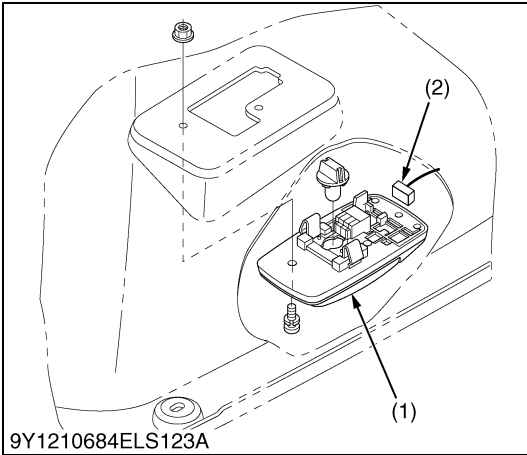

Connector Voltage

1. Disconnect the connector.
2. Measure the voltage with a voltmeter across the terminals shown in the table below.
3. If the reference value is not indicated as shown in the table below, check the relating electric circuit.

Voltage	Terminal 1 – chassis	Approx. battery voltage
---------	----------------------	-------------------------

(1) Room Lamp Switch

(2) Connector (Harness Side)

9Y1210982ELS0061US0

Switch Continuity

1. Check the continuity across the terminals shown in the table below.
2. If the continuity specified below is not indicated, the switch is damaged.

Position		Terminal	
		1	2
Dome light	OFF	●	
	ON	●	●

9Y1210982ELS028US

(1) Connector (Switch Side)

9Y1210982ELS0062US0

[7] WARNING LAMP, INDICATOR LAMP AND GAUGE

(1) Instrument Panel (ROPS Model)

Connector Voltage

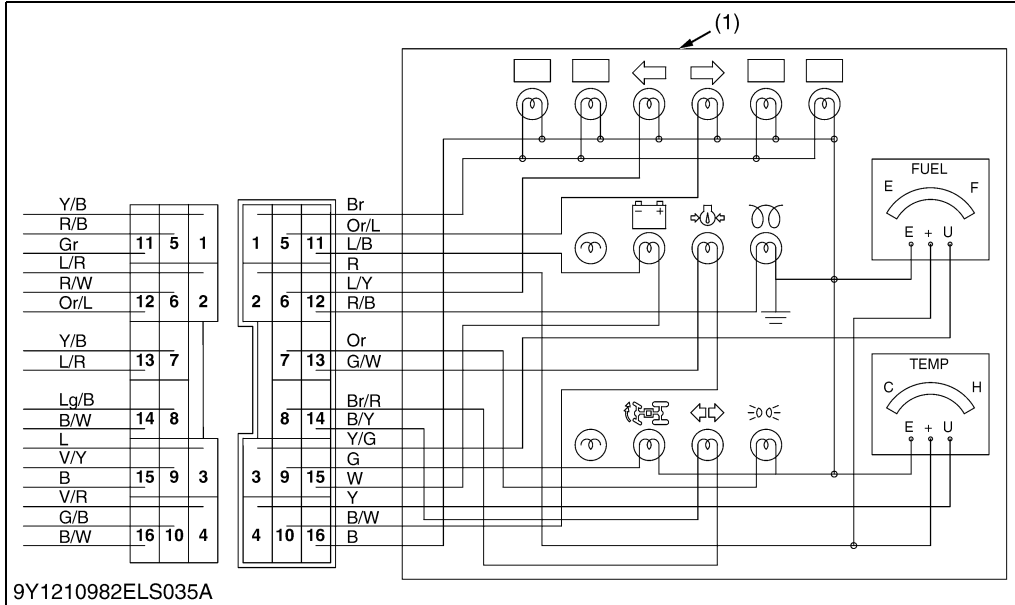

- (1) Instrument Panel
- (2) Connector (Panel)
- (3) Connector (Wire Harness)
- (4) Oil Switch Lamp
- (5) Charge Lamp
- (6) Turn Signal Lamp (R)
- (7) Glow Lamp
- (8) Illumination Lamp
- (9) Bi-speed Turn Indicator Lamp
- (10) Turn Signal Lamp (L)
- (11) Trailer Indicator Lamp
- (12) Position Lamp

9Y1210982ELS035A

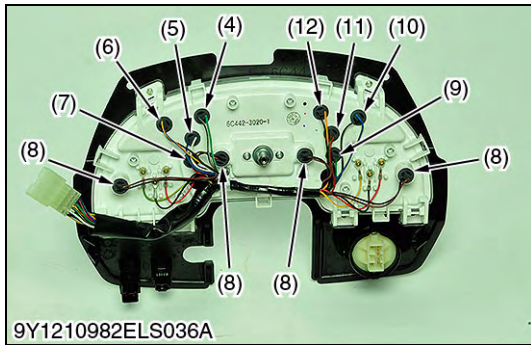

9Y1210982ELS036A

1. Turn on the key switch.
2. Measure the voltage between terminal 2 and chassis.
3. If the measurement is not approximately battery voltage, check the relating circuit.

Voltage	Terminal 2 – Chassis	Approx. battery voltage
---------	----------------------	-------------------------

[Connector Pin Arrangement]

Terminal No.	Item
1	Illumination
2	Key Switch
3	Fuel Gauge
4	Coolant Temperature Sensor
5	Turn Signal (R)
6	Turn Signal (L)
7	Position
8	Trailer Socket (+)
9	Bi-speed Turn Indicator
10	Oil Switch (-)
11	Charge (+)
12	Glow Indicator
13	Oil Switch
14	Trailer Indicator (-)
15	Charge (-)
16	GND

9Y1210982ELS0063US0

(2) Instrument Panel (CABIN Model)

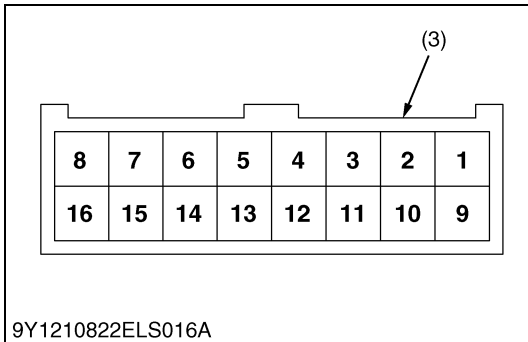
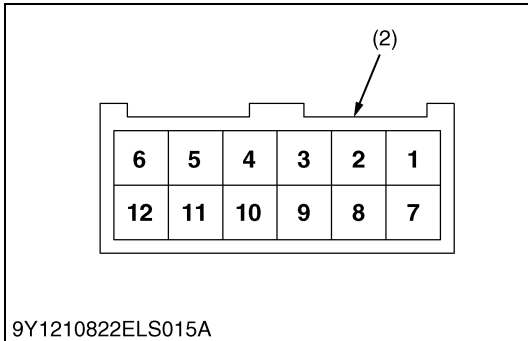
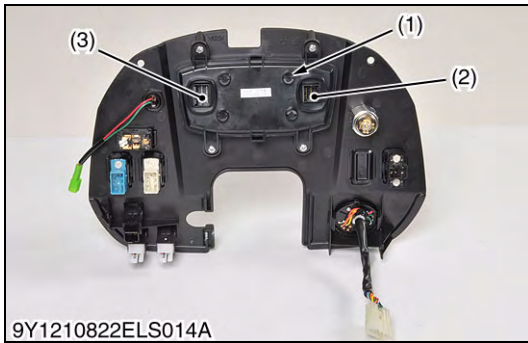

Arrangement of Digital Display Connector Pin

[Connector 1]

Terminal No.	Item	Color of wiring
1	Blank	-
2	Bi-speed Turn Indicator	R
3 to 5	Blank	-
6	L Terminal (Charge)	L/R
7	Blank	-
8	Position	P/B
9 to 10	Blank	-
11	PTO ON/OFF Switch	Lg
12	Turn Signal (L)	G

[Connector 2]

Terminal No.	Item	Color of wiring
1	Turn Signal (R)	G/R
2	Glow Plug Indicator	W
3	Oil Switch	W/R
4 to 5	Blank	-
6	Trailer Indicator	P
7 to 8	Blank	-
9	Fuel Gauge	V
10	Water Temperature Gauge	L
11	GND	B
12	Display Switch	P/W
13	Engine Revolution	Sb
14	Blank	-
15	Battery	Y/L
16	Main Switch	Br

(1) Digital Display

(2) Connector 1 (Display Side)

(3) Connector 2 (Display Side)

9Y1210982ELS0064US0

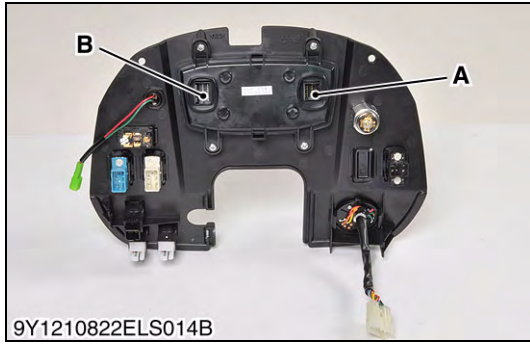

9Y1210822ELS014B

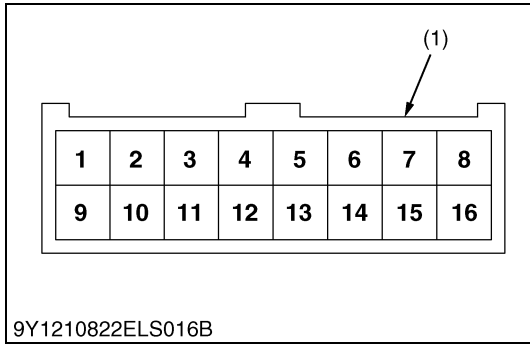

9Y1210822ELS016B

Connector Voltage

1. Disconnect the connector of connector 2 side.
2. Measure the voltage between terminal **15 (+)** (Yellow/Blue) and terminal **11 (-)** (Black).
3. Turn the main key switch **ON**.
4. Measure the voltage between terminal **16 (+)** (Brown) and terminal **11 (-)** (Black).
5. If the measure is not approximately battery voltage, check the relating electric circuit.

Voltage	Terminal 15 – 11	Approx. battery voltage
	Terminal 16 – 11	Approx. battery voltage

(1) Connector (Harness Side)

A: Connector 1
B: Connector 2

9Y1210982ELS0065US0

(3) Engine Oil Pressure Switch

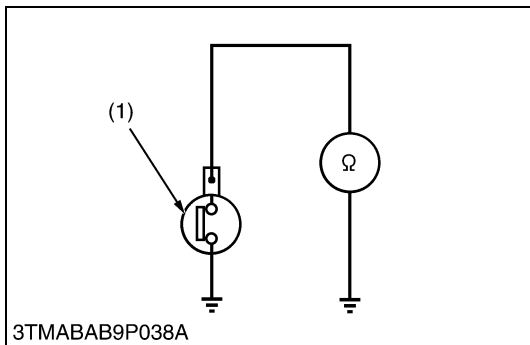

3TMABAB9P038A

Engine Oil Pressure Switch Continuity

1. Measure the resistance with an ohmmeter across the switch terminal and the chassis.
2. If 0 Ω is not indicated in the normal state, the switch is damaged.
3. If infinity is not indicated at pressure over 49 kPa (0.50 kgf/cm², 7.1 psi), the switch is damaged.

Resistance (Switch terminal – Chassis)	In normal state	0 Ω
	At pressure over approx. 49 kPa (0.50 kgf/cm ² , 7.1 psi)	Infinity

(1) Engine Oil Pressure Switch

9Y1210982ELS0066US0

(4) Coolant Temperature Sensor (ROPS Model)

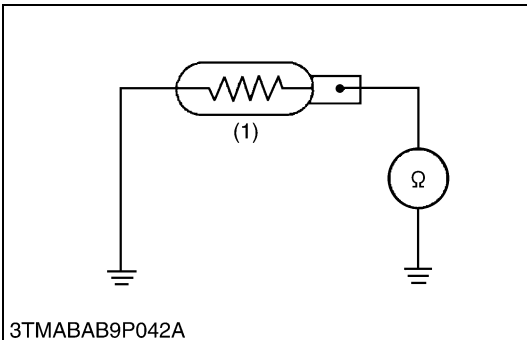
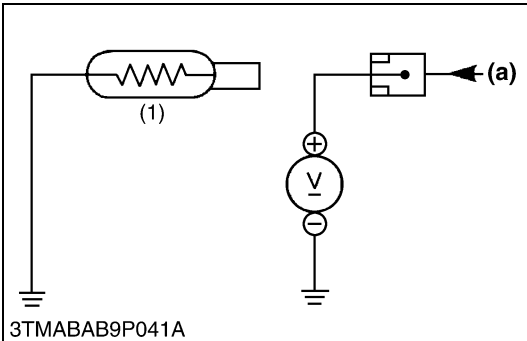
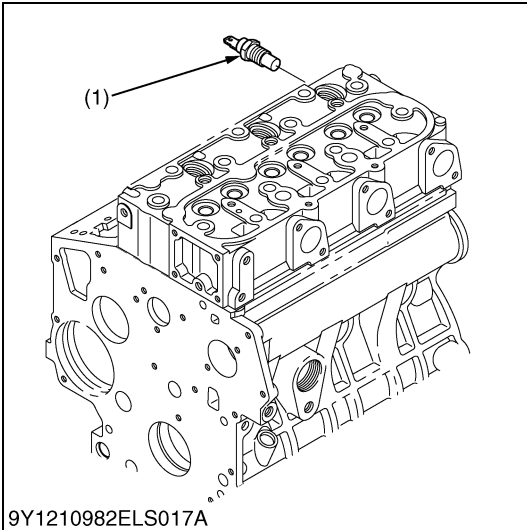

Coolant Temperature Sensor (ROPS Model)

1) Lead Terminal Voltage

1. Disconnect the lead from the coolant temperature sensor after turning the main switch **OFF**.
2. Turn the main switch **ON** and measure the voltage with a voltmeter across the lead terminal and the chassis. If the voltage differs from the battery voltage, the wiring harness fuse or coolant temperature gauge is damaged.

Voltage	Lead terminal – Chassis	Approx. 5 V
---------	-------------------------	-------------

2) Sensor Continuity

1. Measure the resistances with an ohmmeter across the sensor terminal and the chassis.
2. If the reference value is not indicated, the sensor is damaged.

Resistance (Sensor terminal – Chassis)	Reference value	Approx. 12.2 Ω at 130 °C (266 °F) Approx. 23.6 Ω at 105 °C (221 °F) Approx. 51.9 Ω at 80 °C (176 °F) Approx. 153.9 Ω at 50 °C (122 °F)
--	-----------------	---

Tightening torque	Coolant temperature sensor	11.8 to 17.6 N·m 1.20 to 1.80 kgf·m 8.68 to 13.0 lbf·ft
-------------------	----------------------------	---

(1) Coolant Temperature Sensor

(a) From Temperature Gauge

9Y1210982ELS0067US0

(5) Coolant Temperature Sensor (CABIN Model)

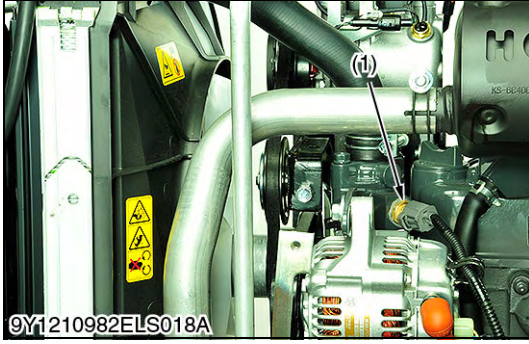

Connector Voltage

1. Disconnect the connector and turn the key switch "ON" position.
2. Measure the voltage with a voltmeter across the terminals shown in the table below.
3. If the reference value is not indicated as shown in the table below, check the relating electric circuit.

Voltage	Key switch at "ON"	Terminal 2 – chassis	Approx. 5 V
---------	--------------------	----------------------	-------------

- (1) Coolant Temperature Sensor (2) Connector (Harness Side)

9Y1210982ELS0068US0

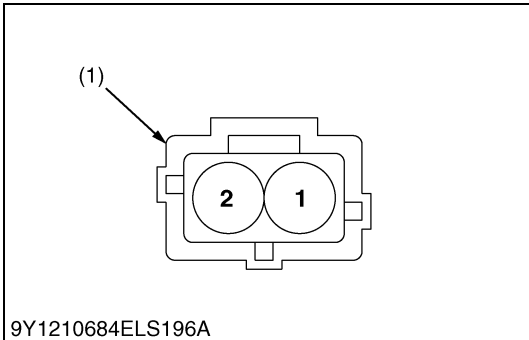
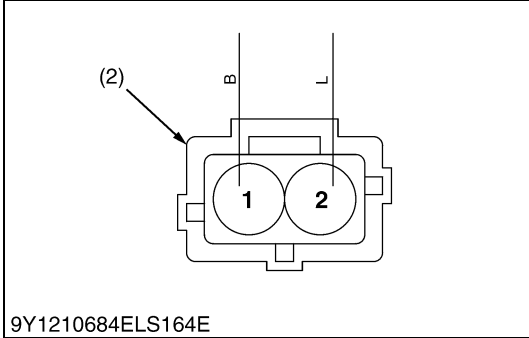

Sensor Resistance

1. Measure the resistance with an ohmmeter across the terminals shown in the table below.
2. If the reference value is not indicated, the intake air temperature sensor is damaged.

Resistance	at -20 °C (-4 °F)	Terminal 1 – 2	Approx. 15.0 kΩ
	at 20 °C (68 °F)		Approx. 2.45 kΩ
	at 80 °C (176 °F)		Approx. 0.318 kΩ

Tightening torque	Coolant temperature sensor	Less than 19.6 N·m 2.00 kgf·m 14.5 lbf·ft
-------------------	----------------------------	--

- (1) Connector (Sensor Side)

A: Resistance
B: Temperature

9Y1210982ELS0069US0

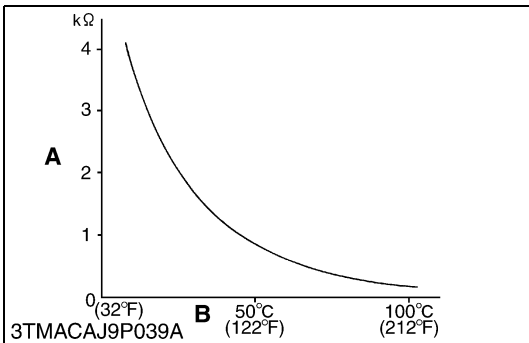

(6) Fuel Sensor

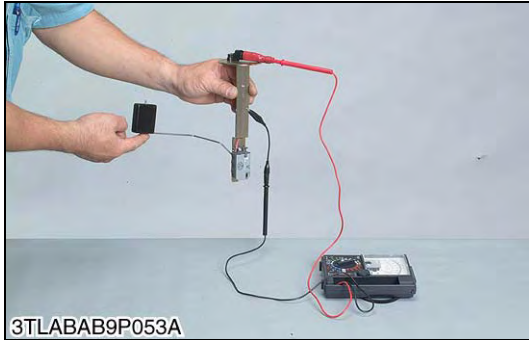
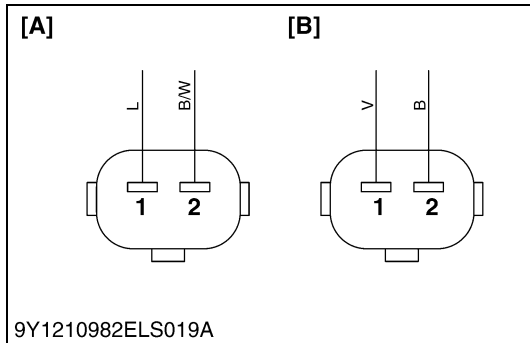

Fuel Sensor

1) Connector Voltage

1. Disconnect the connector and turn the key switch "ON" position.
2. Measure the voltage with a voltmeter across the terminals shown in the table below.
3. If the reference value is not indicated as shown in the table below, check the relating electric circuit.

Voltage	Key switch at "ON"	Terminal 1 – chassis	Approx. 5 V
---------	--------------------	----------------------	-------------

2) Sensor Continuity

1. Remove the fuel lever sensor from the fuel tank.
2. Measure the resistance across the sensor terminal and its body.
3. If the reference value are not indicated, the sensor is damaged.

Resistance (Sensor terminal – its body)	Reference value	Float at upper-most position	2 to 4 Ω
		Float at lower-most position	109 to 111 Ω

- (1) Fuel Sensor Connector (Harness Side) [A] ROPS Model [B] CABIN Model

9Y1210982ELS0070US0

(7) Bi-speed Turn Switch

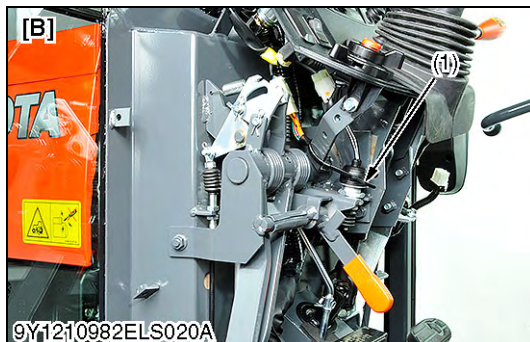

Bi-speed Turn Switch Continuity

1. Disconnect the switch connector.
2. Connect the circuit tester to the switch connector.
3. Measure the resistance between terminals.
4. If the switch is damaged, replace it.

Bi-speed turn switch	When bi-speed turn lever is at normal 4WD position	Infinity
	When bi-speed turn lever is at bi-speed turn 4WD position	0 Ω

- (1) Bi-speed Turn Switch [A] ROPS Model [B] CABIN Model

9Y1210982ELS0071US0

(8) Engine Rotation Sensor (CABIN Model Only)

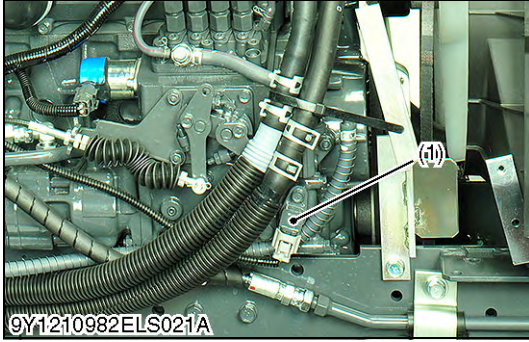

Connector Voltage

1. Disconnect the connector, and turn the key switch "ON" position.
2. Measure the voltage with a voltmeter across the terminals shown in the table below.
3. If the reference value is not indicated as shown in the table below, check the relating electric circuit.

Voltage	Key switch at "ON"	Terminal 1 – chassis	Approx. battery voltage
		Terminal 2 – chassis	Approx. 5 V

(1) Engine Rotation Sensor

(2) Connector (Harness Side)

9Y1210982ELS0072US0

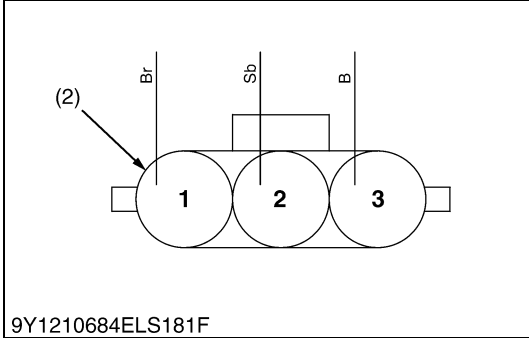

Sensor Actuation Test

1. Disconnect the connector of the engine rotation sensor.
2. Connect a connector of the rotation sensor signal interface unit (2) to the engine rotation sensor (1).
3. Connect each clip of the rotation sensor signal interface unit (2) to the same test lead color of the circuit tester (3).
4. Switch on the rotation sensor signal interface unit (2).
5. Turn the flywheel and make sure that the voltage of the engine speed sensor goes from 0 → 5 V or 5 → 0 V.
6. If there is no change in the voltage, replace the engine rotation sensor.

(1) Engine Rotation Sensor

(3) Circuit Tester

(2) Rotation Sensor Signal Interface Unit

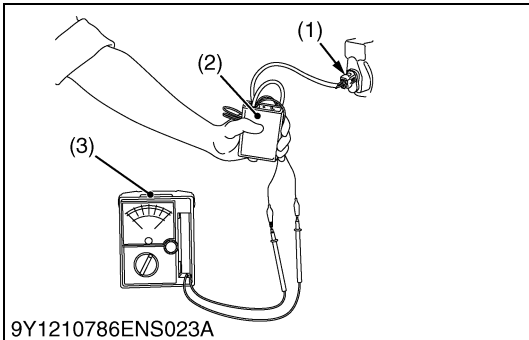

9Y1210982ELS0073US0

(9) Display Switch

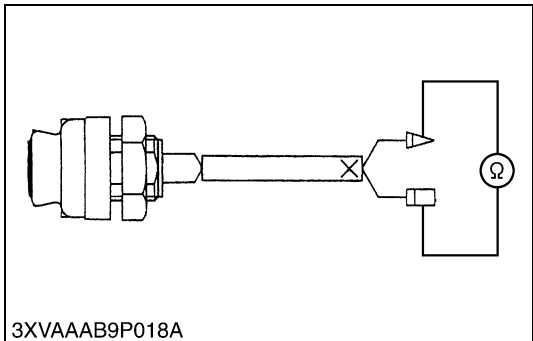
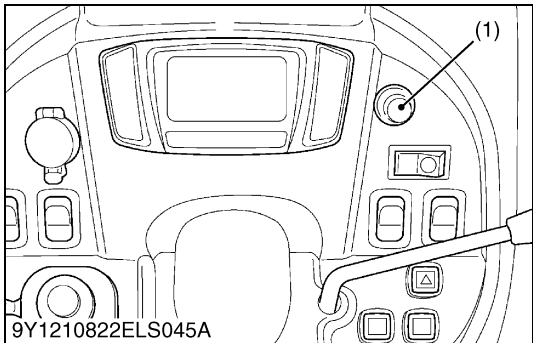

Display Switch Continuity

1. Disconnect the wiring leads from display switch and remove it.
2. Measure the resistance with an ohmmeter across the display switch terminals in each position.
3. If the resistance differs from the factory specifications, the display switch is damaged.

Resistance	Factory specification	OFF	Infinity
		ON	0 Ω

(1) Display Switch

9Y1210982ELS0074US0

5. DISASSEMBLING AND ASSEMBLING

[1] STARTER

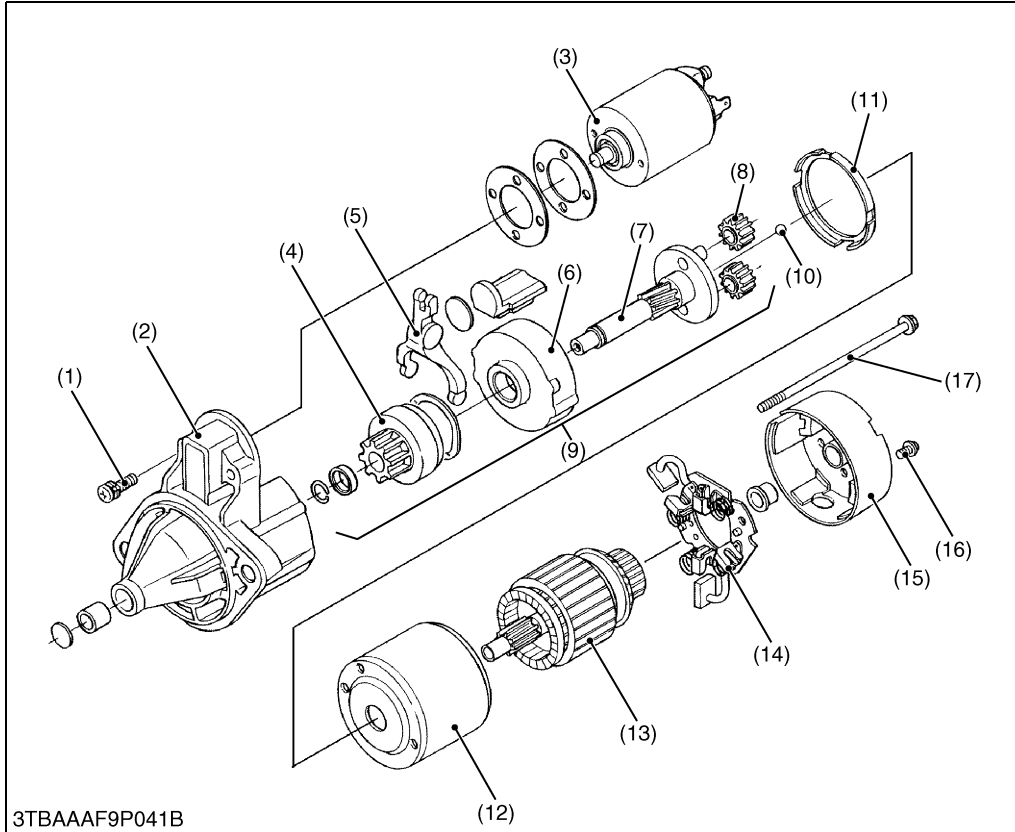

- (1) Screw
- (2) Front Bracket
- (3) Magnetic Switch
- (4) Overrunning Clutch
- (5) Drive Lever
- (6) Internal Gear
- (7) Shaft
- (8) Planetary Gear
- (9) Shaft Assembly
- (10) Ball
- (11) Gasket
- (12) Yoke
- (13) Armature
- (14) Brush Holder
- (15) Rear End Frame
- (16) Screw
- (17) Through Bolt

3TBAAAF9P041B

1. Disconnect the connecting lead from the magnetic switch (3).
2. Remove the screw (1) and remove the magnet switch (3).
3. Remove the screw (16) and through bolt (17), and separate the rear end frame (15).
4. Remove the brush holder (14).
5. Draw out the armature (13) and yoke (12).
6. Remove the gasket (11), gasket (19) and plate (18).
7. Draw out the shaft assembly (9) with the drive lever (5).

■ **NOTE**

- Do not damage the brush and commutator.
- Do not miss the ball (10).

9Y1210982ELS0075US0

[2] ALTERNATOR

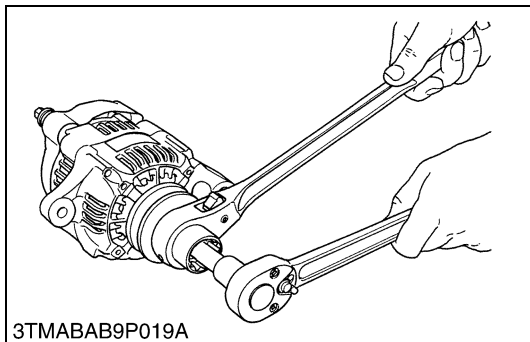

3TMABAB9P019A

Pulley

1. Secure the hexagonal end of the pulley shaft with a double-ended ratchet wrench as shown in the figure, loosen the pulley nut with a socket wrench and remove it.

(When reassembling)

Tightening torque	Pulley nut	58.3 to 78.9 N·m 5.95 to 8.05 kgf·m 43.0 to 58.2 lbf·ft
-------------------	------------	---

9Y1210982ELS0076US0

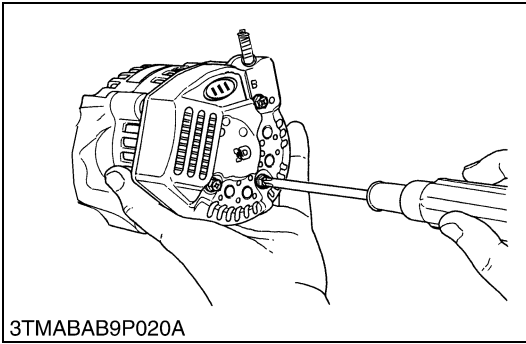

3TMABAB9P020A

Rear End Cover

1. Remove the three rear end cover screws and the **B** terminal nut, and remove the rear end cover.

9Y1210982ELS0077US0

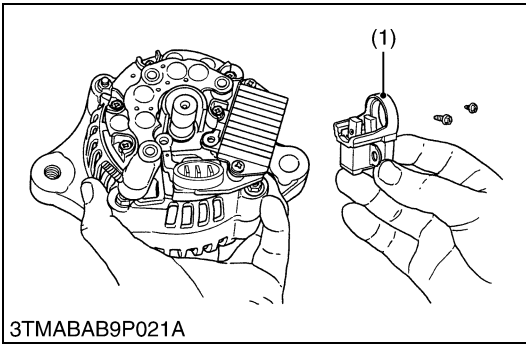

3TMABAB9P021A

Brush Holder

1. Remove the two screws holding the brush holder, and remove the brush holder (1).

- (1) Brush Holder

9Y1210982ELS0078US0

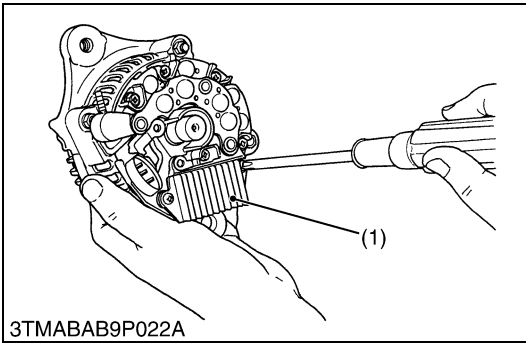

3TMABAB9P022A

IC Regulator

1. Remove the three screws holding the IC regulator, and remove the IC regulator (1).

- (1) IC Regulator

9Y1210982ELS0079US0

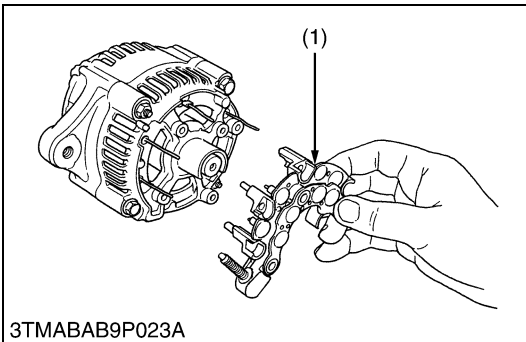

3TMABAB9P023A

Rectifier

1. Remove the four screws holding the rectifier and the stator lead wires.
2. Remove the rectifier (1).

- (1) Rectifier

9Y1210982ELS0080US0

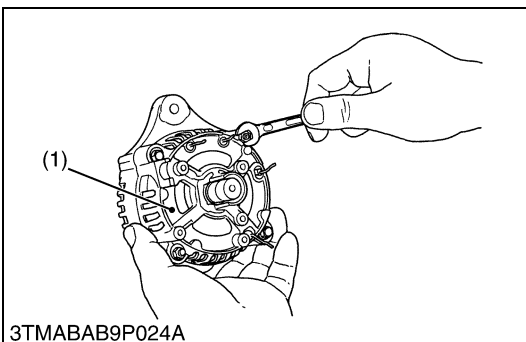

3TMABAB9P024A

Rear End Frame

1. Remove the two nuts and two screws holding the drive end frame and the rear end frame.
2. Remove the rear end frame (1).

- (1) Rear End Frame

9Y1210982ELS0081US0

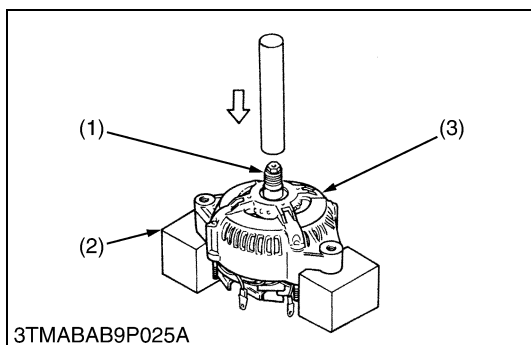
**Rotor**

1. Press out the rotor (1) from drive end frame (3).

■ **IMPORTANT**

- Take special care not to drop the rotor and damage the slip ring or fan, etc..

(1) Rotor
(2) Block

(3) Drive End Frame

9Y1210982ELS0082US0

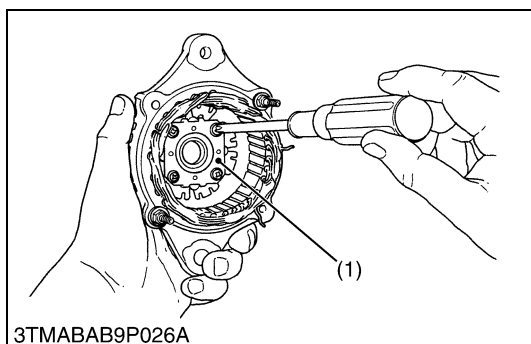
**Retainer Plate**

1. Remove the four screws holding the retainer plate, and remove the retainer plate (1).

(1) Retainer Plate

9Y1210982ELS0083US0

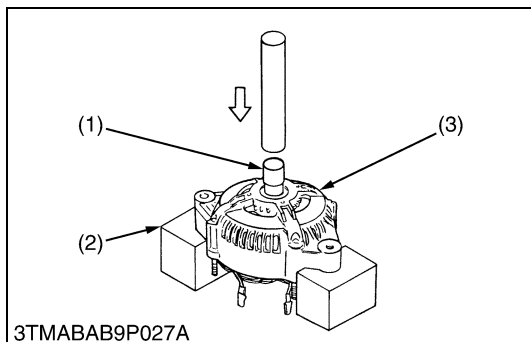
**Bearing on Drive End Side**

1. Press out the bearing from drive end frame (3) with a press and jig (1).

(1) Jig
(2) Block

(3) Drive End Frame

9Y1210982ELS0084US0

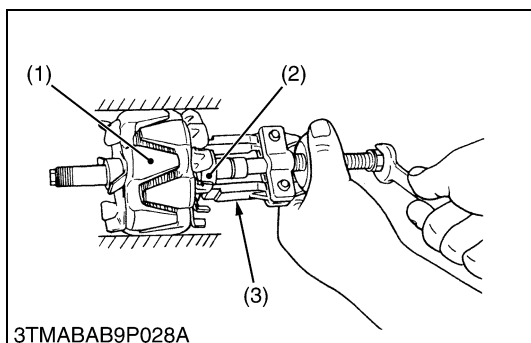
**Bearing at Slip Ring Side**

1. Lightly secure the rotor (1) with a vise to prevent damage, and remove the bearing (2) with a puller (3).

(1) Rotor
(2) Bearing

(3) Puller

9Y1210982ELS0085US0

6. SERVICING

[1] STARTER

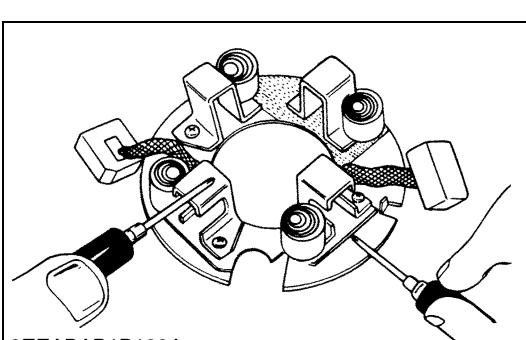
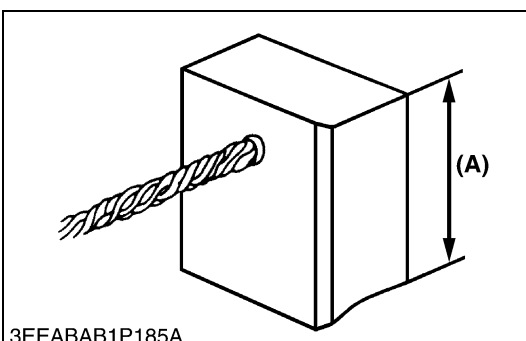
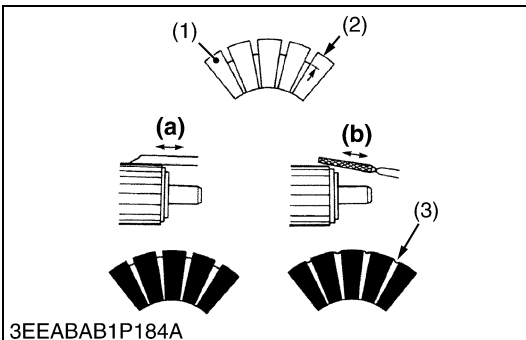
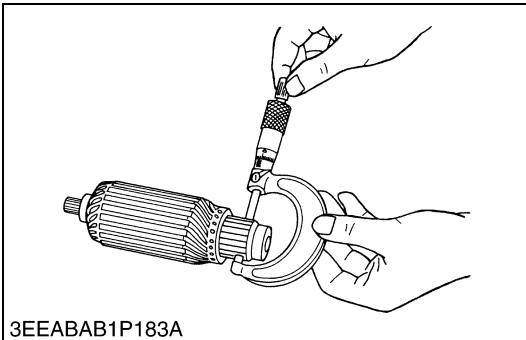
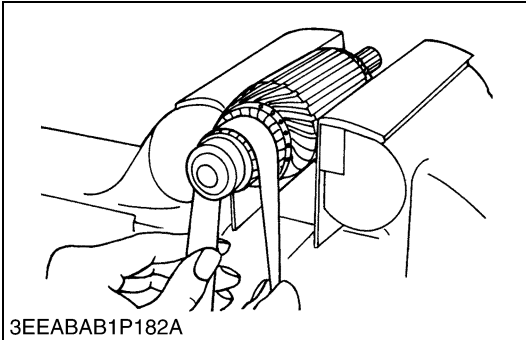

Commutator and Mica

1. Check the contact face of the commutator for wear, and grind the commutator with emery paper if it is slightly worn.
2. Measure the commutator O.D. with an outside micrometer at several points.
3. If the minimum O.D. is less than the allowable limit, correct the commutator on a lathe to the factory specification.
4. Measure the mica undercut.
5. If the undercut is less than the allowable limit, correct it with a saw blade and chamfer the segment edges.

Commutator O.D.	Factory specification	28.0 mm 1.102 in.
	Allowable limit	27.0 mm 1.063 in.

Difference of O.D.'s	Factory specification	Less than 0.02 mm 0.0008 in.
	Allowable limit	0.05 mm 0.0020 in.

Mica undercut	Factory specification	0.60 mm 0.0236 in.
	Allowable limit	0.20 mm 0.0079 in.

- (1) Segment
 - (2) Undercut
 - (3) Mica
- (a) Correct
 - (b) Incorrect

9Y1210982ELS0086US0

Brush Wear

1. If the contact face of the brush is dirty or dusty, clean it with emery paper.
2. Measure the brush length (A) with vernier calipers.
3. If the length is less than the allowable limit, replace the yoke assembly and brush holder.

Brush length (A)	Factory specification	14.0 mm 0.551 in.
	Allowable limit	9.0 mm 0.354 in.

9Y1210982ELS0087US0

Brush Holder

1. Check the continuity across the brush holder and the holder support with an ohmmeter.
2. If it conducts, replace the brush holder.

Resistance	Brush holder – Holder support	Infinity
------------	-------------------------------	----------

9Y1210982ELS0088US0

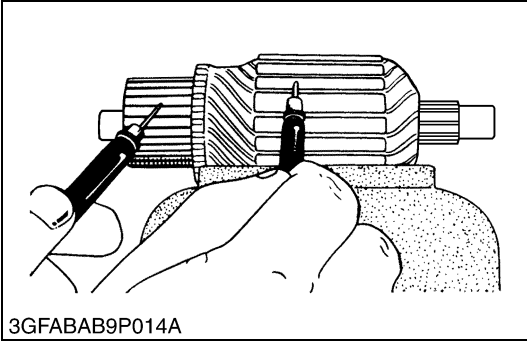

Armature Coil

1. Check the continuity between the commutator and armature coil core with an ohmmeter.
2. If it conducts, replace the armature.
3. Check the continuity between the segments of the commutator with an ohmmeter.
4. If it does not conduct, replace the armature.

9Y1210982ELS0089US0

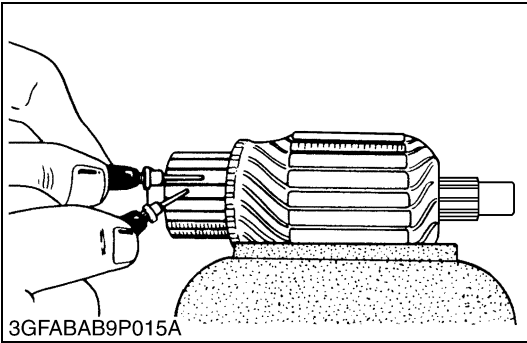

[2] ALTERNATOR

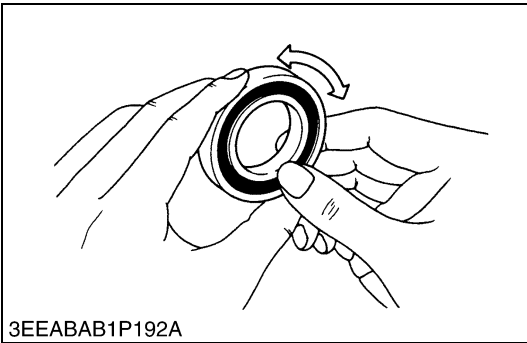

Bearing

1. Check the bearing for smooth rotation.
2. If it does not rotate smoothly, replace it.

9Y1210982ELS0090US0

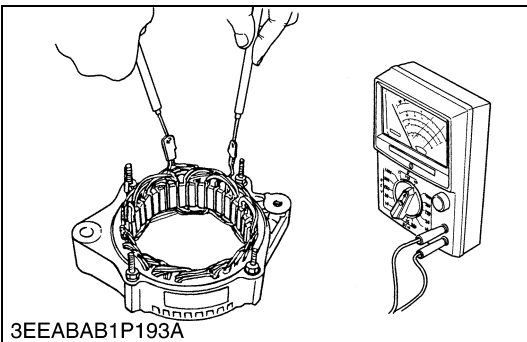

Stator

1. Measure the resistance across each lead of the stator coil with an ohmmeter.
2. If the measurement is not within the factory specification, replace it.
3. Check the continuity across each stator coil lead and core with an ohmmeter.
4. If infinity is not indicated, replace it.

Resistance	Factory specification	Less than 1.0 Ω
------------	-----------------------	-----------------

9Y1210982ELS0091US0

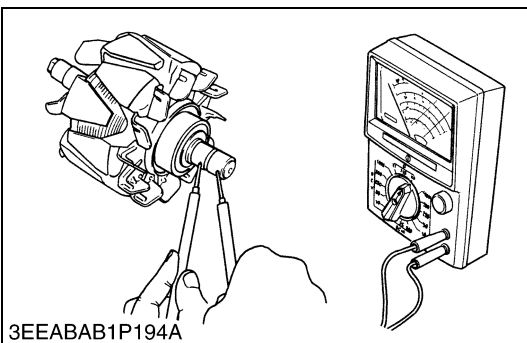

Rotor

1. Measure the resistance across the slip rings with an ohmmeter.
2. If the resistance is not the factory specification, replace it.
3. Check the continuity across the slip ring and core with an ohmmeter.
4. If infinity is not indicated, replace it.

Resistance	Factory specification	2.9 Ω
------------	-----------------------	-------

9Y1210982ELS0092US0

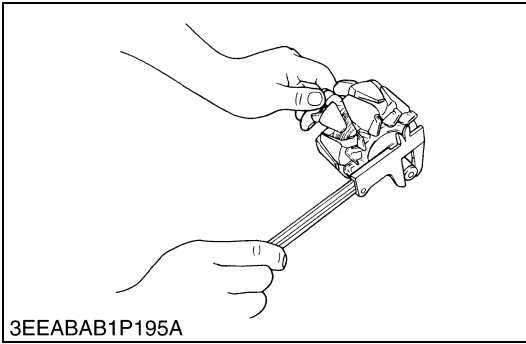

Slip Ring

1. Check the slip ring for score.
2. If scored, correct with an emery paper or on a lathe.
3. Measure the O.D. of slip ring with vernier calipers.
4. If the measurement is less than the allowable limit, replace it.

Slip ring O.D.	Factory specification	14.4 mm 0.567 in.
	Allowable limit	12.8 mm 0.504 in.

9Y1210982ELS0093US0

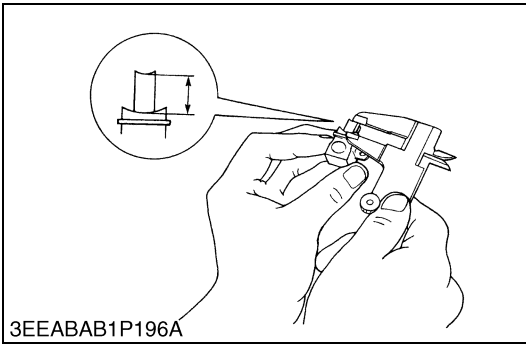

Brush Wear

1. Measure the brush length with vernier calipers.
2. If the measurement is less than allowable limit, replace it.
3. Make sure that the brush moves smoothly.
4. If the brush is damaged, replace it.

Brush length	Factory specification	10.5 mm 0.413 in.
	Allowable limit	8.4 mm 0.331 in.

9Y1210982ELS0094US0

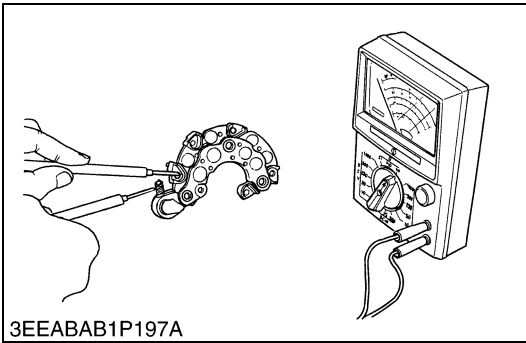

Rectifier

1. Check the continuity across each diode of rectifier with an analog ohmmeter. Conduct the test in the (R × 1) setting.
2. The rectifier is normal if the diode in the rectifier conducts in one direction and does not conduct in the reverse direction.

■ **IMPORTANT**

- Do not use a 500 V megohmmeter for measuring because it will destroy the rectifier.

■ **NOTE**

- Do not use an auto digital multimeter. Because it's very hard to check the continuity of rectifier by using it.

9Y1210982ELS0095US0

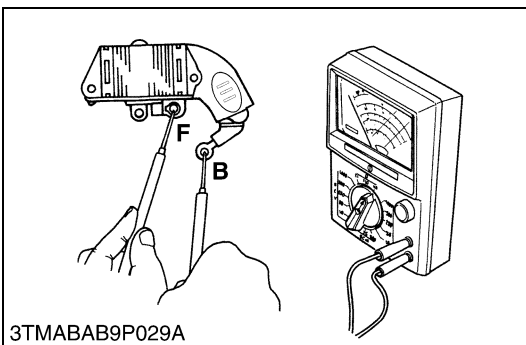

IC Regulator

1. Check the continuity across the B terminal and the F terminal of IC regulator with an analog ohmmeter. Conduct the test in the (R × 1) setting.
2. The IC regulator is normal if the IC regulator conducts in one direction and does not conduct in the reverse direction.

■ **IMPORTANT**

- Do not use a 500 V megohmmeter for measuring because it will destroy the IC regulator.

■ **NOTE**

- Do not use an auto digital multimeter. Because it's very hard to check the continuity of IC regulator by using it.

9Y1210982ELS0096US0

10 CABIN

MECHANISM

CONTENTS

1. OUTLINE OF AIR CONDITIONING SYSTEM	10-M1
[1] STRUCTURE	10-M1
[2] AIR CONDITIONING SYSTEM	10-M3
2. REFRIGERATION SYSTEM	10-M4
[1] COMPRESSOR.....	10-M4
(1) Pressure Relief Valve	10-M5
(2) Magnetic Clutch	10-M5
[2] CONDENSER.....	10-M6
[3] RECEIVER	10-M7
[4] AIR CONDITIONER UNIT	10-M8
(1) Evaporator	10-M9
(2) Heater Core	10-M10
3. SYSTEM CONTROL	10-M11
4. ELECTRICAL SYSTEM.....	10-M12
[1] ELECTRICAL CIRCUIT	10-M12
[2] RELAY	10-M13

1. OUTLINE OF AIR CONDITIONING SYSTEM

[1] STRUCTURE

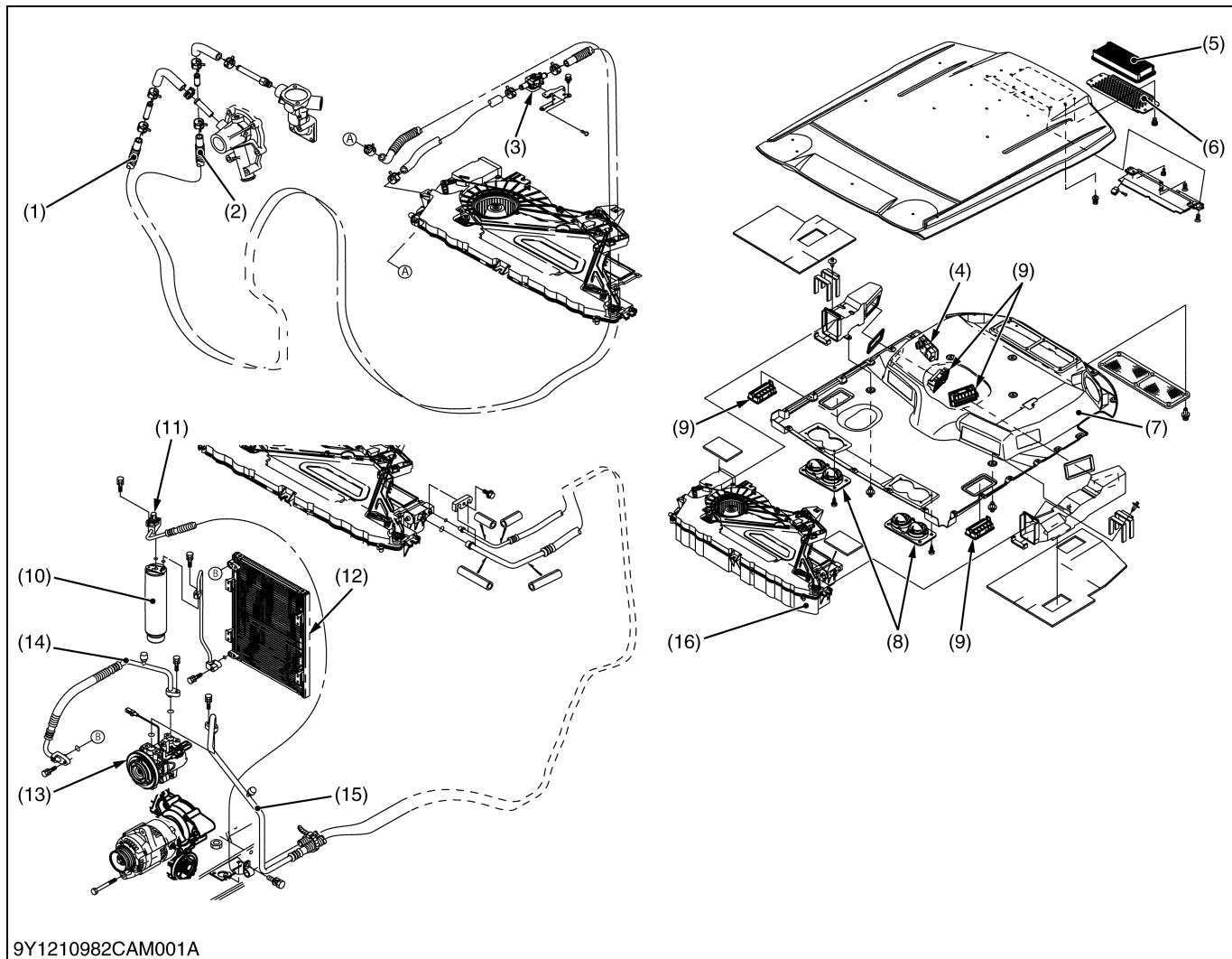

9Y1210982CAM001A

- | | | | |
|---------------------------|------------------------|----------------------|---------------------------|
| (1) Heater Hose (Outside) | (5) Outside Air Filter | (9) Side Air Outlet | (13) Compressor |
| (2) Heater (Inside) | (6) Inside Air Filter | (10) Receiver | (14) High Pressure Pipe |
| (3) Water Valve | (7) Inner Roof | (11) Pressure Switch | (15) Low Pressure Pipe |
| (4) Control Panel | (8) Front Air Outlet | (12) Condenser | (16) Air Conditioner Unit |

(To be continued)

(Continued)

The machine is equipped with a thin large-capacity air conditioner with outside air intake. Air pulled from the inside air filter (6) as well as the outside air filter (5), passes through the roof (7) and reaches the air conditioner unit (16). The air is then cooled and dehumidified by this unit.

The processed air is then heated to a comfortable level. In this way, the air being blown via the blow port can be kept at comfortable temperature and humidity.

The front air outlet (8) can be opened and closed using the center knob of each port. The side air outlet (9) are opened and closed using the mode lever on the control panel (4). With these ports opened or closed, you can feel your head cool and your feet warm.

Capacity (Cooling)	Factory specification	2.8 to 3.4 kW
Capacity (Warming)	Factory specification	3.8 to 4.7 kW
Kinds of refrigerant (Charging amount)	Factory specification	R134a 650 to 710 kg 1.44 to 1.56 lbs
Pressure sensor (Low)	Factory specification	0.196 MPa 2.0 kgf/cm ² 28.4 psi
Pressure sensor (High)	Factory specification	3.14 MPa 32.0 kgf/cm ² 455 psi

■ **NOTE**

- As for the mechanism and function of each component part, refer to Workshop Manual of "MECHANISM".

9Y1210982CAM0001US0

[2] AIR CONDITIONING SYSTEM

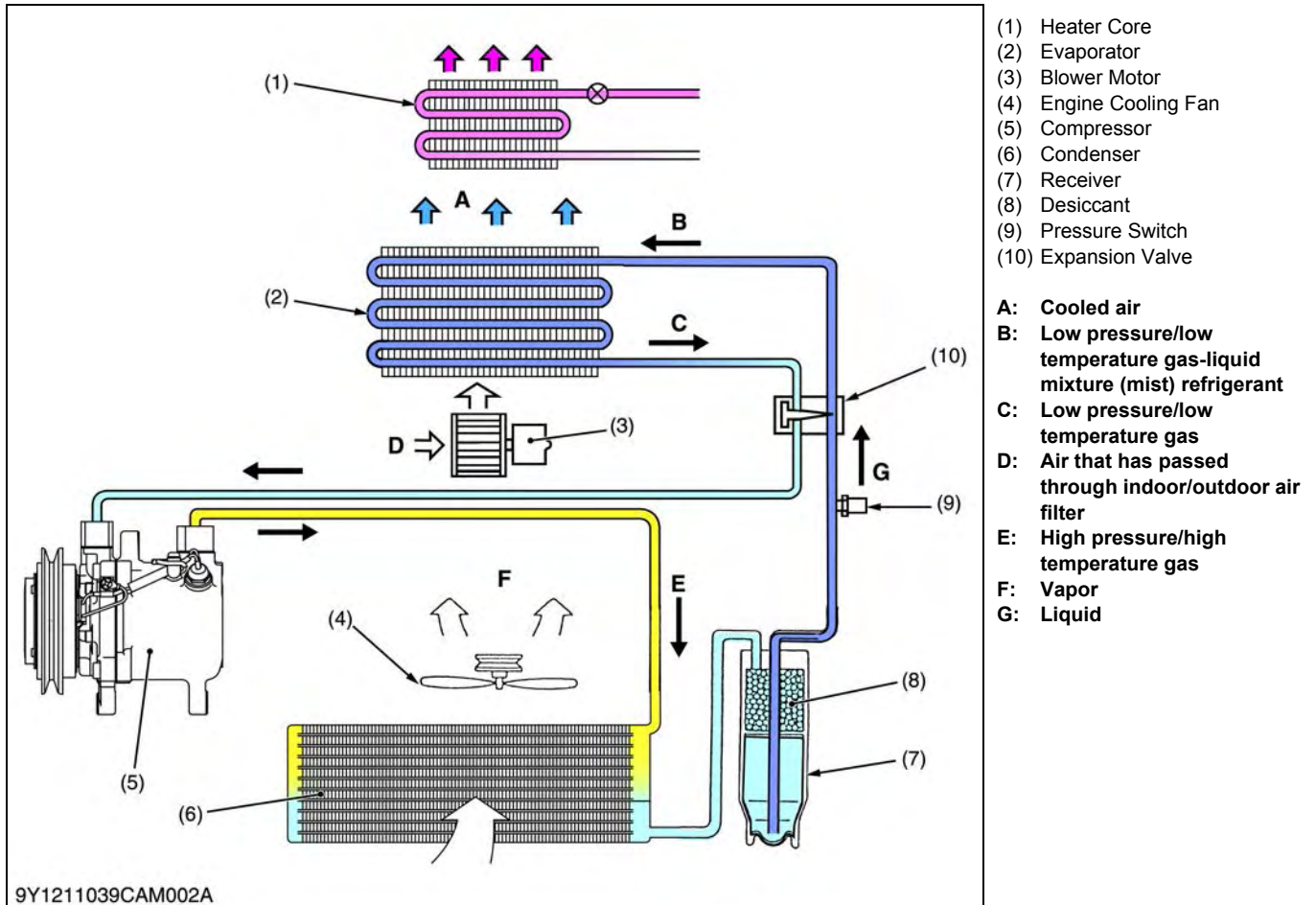

The cooling system for this air conditioning device is as follows.

1. Refrigerant in gaseous state that has passed through and vaporized in the evaporator (2) is compressed to approximately 1.47 MPa (15 kgf/cm²) by the compressor (5). Here, the temperature rises to approximately 70 °C. Refrigerant in this state is sent to the condenser (6).
2. The gaseous refrigerant passes through the condenser (6) and is cooled to approximately 50 °C, changes from a gas to a liquid, and is sent to the receiver (7).
3. Refrigerant collected in the receiver (7) is stored for supplying of refrigerant based on the air conditioning load. Also, desiccant (8) is enclosed in the receiver and this separates out water in the case that there is water in the refrigerant.
4. Next, liquid refrigerant is sent to the expansion valve (10). The refrigerant is sprayed in an atomized state into the evaporator (2) through the small hole in this valve. This causes the pressure and temperature of the refrigerant to drop enabling vaporization of the refrigerant.
5. The refrigerant actively vaporizes through collecting heat from the surface of the evaporator (2) pipes.
6. Here, the heat from air pulled into the evaporator using a blower motor (3) is collected by vaporization of the refrigerant. The inside of the cabin is cooled through discharge of this air into the cabin.

(Remarks)

- Air that passes into the evaporator is rapidly cooled so water contained in the air is condensed. In other words, this enables dehumidification of the cabin.
- Air that has passed through the evaporator is separated into air that enters the heater core (1) and air that does not enter by an air mix door. In other words, the air can be discharged into the cabin at the desired temperature.
- Refrigerant that has been vaporized in the evaporator (2) is returned to the compressor (5), is again compressed and changed high temperature high pressure gas.

9Y1210982CAM0002US0

2. REFRIGERATION SYSTEM

[1] COMPRESSOR

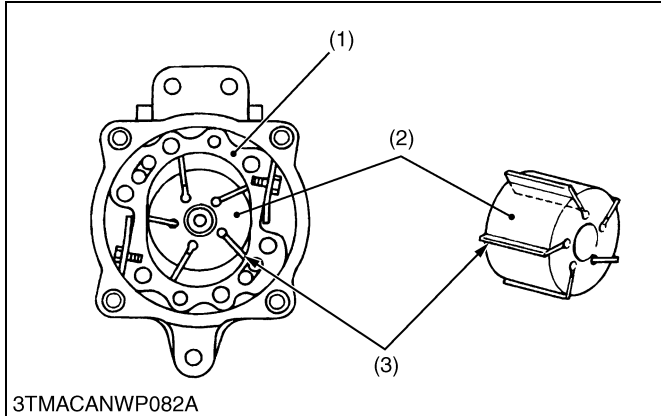

The vane type compressor installed on this cabin consists of a cylinder (1) with an oval cross section and a rotor (2) with five vanes (3). The vane type compressor is provided with two suction ports and two discharge ports respectively.

The five vanes (3) mounted on the rotor (2), rotating along the inner wall of the cylinder (1), keeps air-tightness using the centrifugal force of the rotor (2) and the back pressure of the vanes (3) that grow in proportion to the rotating speed of the rotor (2).

As a result, the volumes of the five cylinder chambers separated with the cylinder (1) and the five vanes (3) change.

For each rotation of the rotor (2), each of the cylinder chambers performs two cycles of inhalation, compression, and discharge.

- (1) Cylinder
- (2) Rotor
- (3) Vane

9Y1210982CAM0003US0

Operation

In proportion to the rotation of the rotor (3), a volume of a cylinder chamber separated with the cylinder (1) and the vanes (4) increases. The cylinder chamber inhales refrigerant gas from the suction port (2).

As the rotor (3) rotates further, a volume of the cylinder chamber separated with the cylinder (1) and the vanes (4) decreases, and the refrigerant gas is compressed. As the rotor (3) rotates even further, the refrigerant gas is highly compressed and then presses the discharge valve to open. The refrigerant gas is discharged from the discharge port (5).

- (1) Cylinder
- (2) Suction Port
- (3) Rotor
- (4) Vane
- (5) Discharge Port
- (A) Compression Process
- (B) Discharge Process
- (C) Suction Process

9Y1210982CAM0004US0

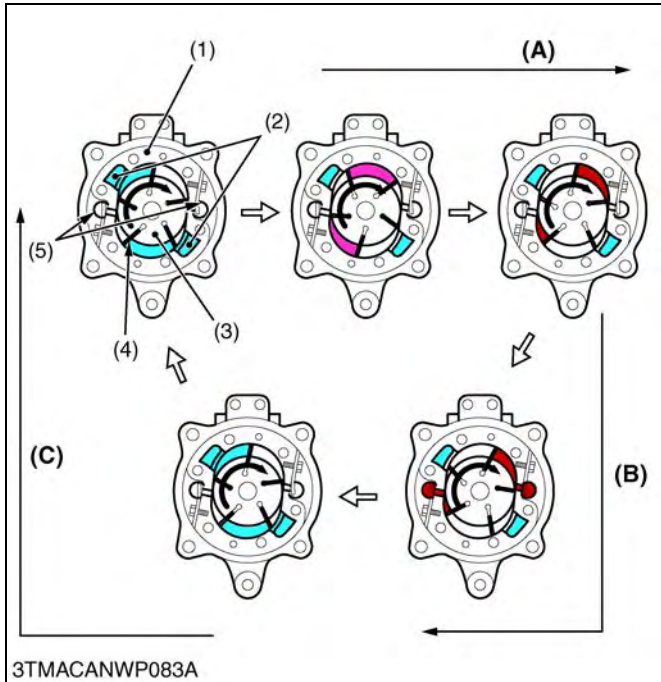

Compressor Oil

The compressor oil dissolves in the refrigerant, circulates through the air-conditioning cycle, and functions to lubricate the compressor. But the conventional compressor oil for R12 does not dissolve in R134a, so it does not circulate through the cycle, and the lifespan of the compressor is considerably shortened.

It is still essential to ensure that the correct refrigerant oil is used. R12 systems were lubricated with mineral oil, which is totally unsuitable for R134a systems. The letter require PAG oil, which mixes very well with the refrigerant and provides ideal lubrication throughout the system.

Quantity (Total)	Brand Name
110 to 120 cc 0.116 to 0.126 U.S.qts 0.0968 to 0.105 Imp.qts	ND-OIL 8 <PAG* oil>

*PAG: Polyalkyleneglycol (Synthetic oil)

9Y1210982CAM0005US0

(1) Pressure Relief Valve



If the high pressure is abnormally high, the pressure relief valve (1) opens to protect the circuit.

Even in the worst case, the outflow of refrigerant is stopped at the minimum limit.

(Reference)

- In normal operation, the high pressure switch is triggered first and the compressor stops, so the pressure relief valve is not triggered so easily.

- (1) Pressure Relief Valve (2) Compressor

9Y1210982CAM006US0

(2) Magnetic Clutch

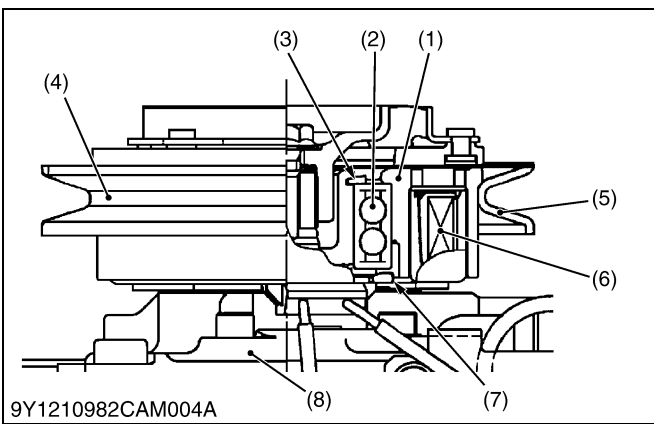

A magnetic clutch is used to engage and disengage the compressor from the engine. Main components are stator (6), rotor with pulley (5), and pressure plate (1) to engage the drive pulley (4) and compressor (8) magnetically.

The stator is fixed on the compressor housing, and the pressure plate (1) is attached to the compressor shaft. Two ball bearings (2) are used between the inner surface of the rotor and the front housing of the compressor.

- | | |
|--------------------|-----------------------|
| (1) Pressure Plate | (5) Rotor with Pulley |
| (2) Ball Bearing | (6) Stator |
| (3) Circlip | (7) Circlip |
| (4) Pulley | (8) Compressor |

9Y1210982CAM007US0

[2] CONDENSER

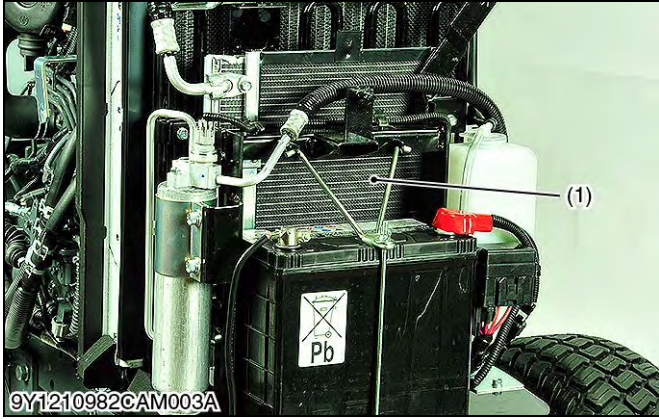

The condenser (1) is installed in the front of the radiator to enable forced cooling by the air drawn in by the engine radiator fan.

The condenser is used for the purpose of cooling by robbing the heat from the refrigerant gas, which has been compressed by the compressor into high temperature, high pressure gas, and change this gas into liquid refrigerant.

The heat given off by the gaseous refrigerant in the condenser is the sum of the heat absorbed at the evaporator and the heat of work required by the compressor to compress the refrigerant. The greater the amount of heat is given off in the condenser, the greater the cooling effect attainable by the evaporator in the cabin.

- (1) Condenser
- (2) Tube
- (3) Fin
- (4) Vapor
- (5) Liquefying
- (6) Liquefied

- a: Gaseous Refrigerant
- b: Liquid Refrigerant
- c: Heated Vapor from Compressor (70 °C, 158 °F)
- d: Cooled Liquid to Receiver (50 °C, 122 °F)

9Y1210982CAM0008US0

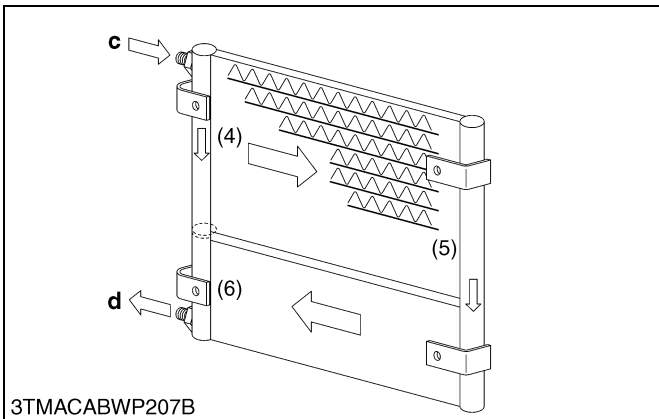
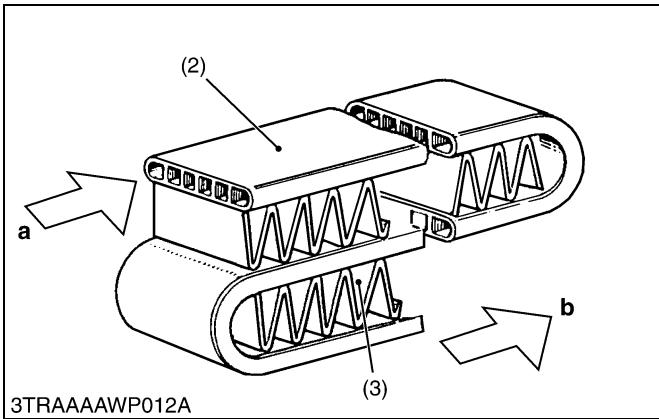

[3] RECEIVER

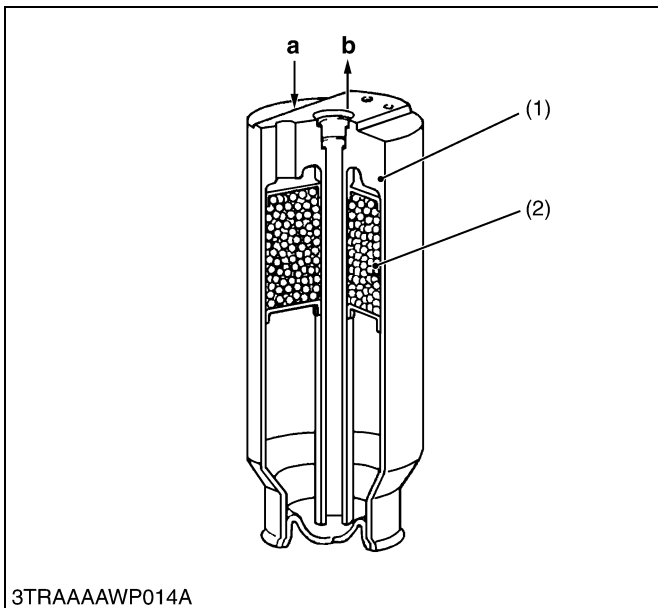
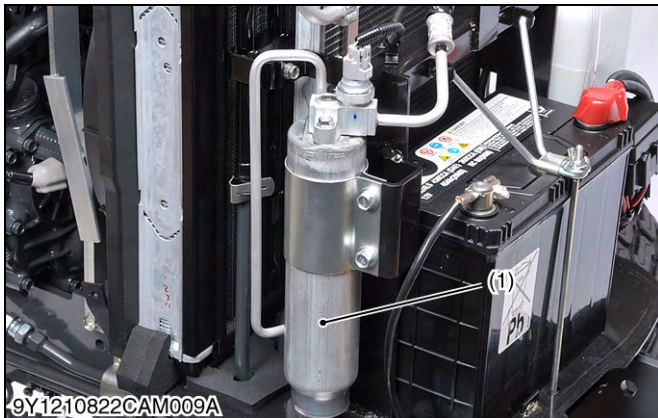

The receiver serves the purpose of storing the liquid refrigerant. The amount of liquid refrigerant flowing through the system varies with the operating condition of the air conditioner. To be accurate, the receiver stores excess refrigerant when the heat load is lowered. It also releases stored refrigerant when additional cooling is needed, thus, keeping the optimum flow of refrigerant within the system.

The receiver includes a desiccant (2). It has the job of removing moisture as the refrigerant circulates within the system.

The sight glass is installed on the top of the receiver. The amount of refrigerant that is charged has a direct effect on the efficiency of the air conditioner. The sight glass is used to check the amount of refrigerant. If a large flow of bubbles can be seen in the sight glass, there is insufficient refrigerant charged. If so, fill the refrigerant to the proper level.

- (1) Receiver Body
- (2) Desiccant

- a: IN
- b: OUT

9Y1210982CAM009US0

[4] AIR CONDITIONER UNIT

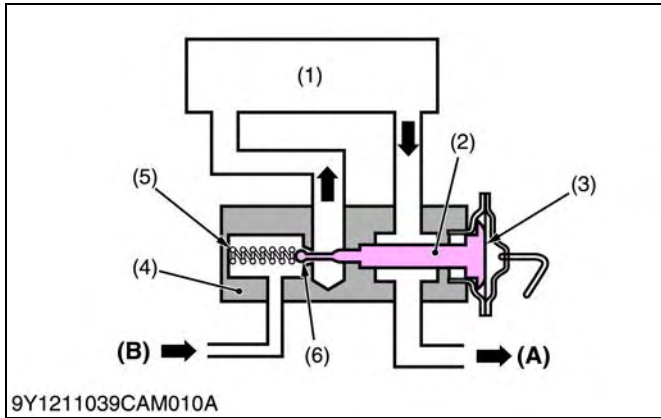
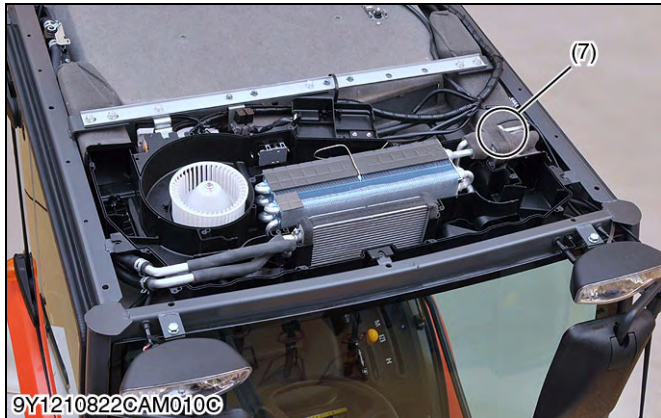
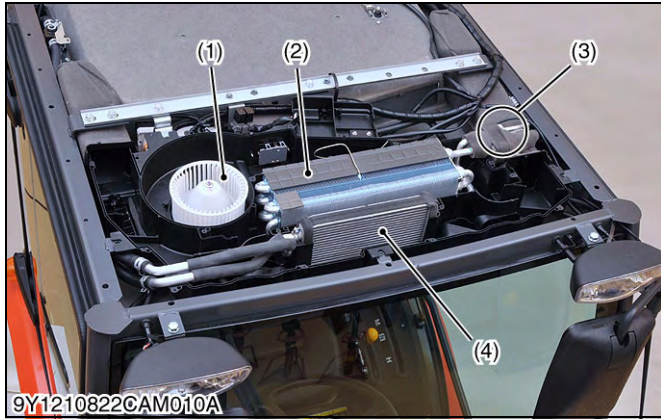

The air conditioner unit consists of evaporator (2), expansion valve (3), heater core (4), blower (1). etc..

- (1) Blower
- (2) Evaporator
- (3) Expansion Valve
- (4) Heater Core

9Y1210982CAM0010US0

Expansion Valve

The expansion valve regulates the amount of liquid refrigerant that passes through the valve. Also, this atomizes the refrigerant for delivery to the evaporator to enable the refrigerant to vaporize readily in the evaporator.

The expansion valve is made up of a diaphragm, temperature sensing rod, and needle valve (ball) etc. and refrigerant gas is enclosed in the diaphragm. The evaporator outlet pressure is applied to the outside of the diaphragm.

In the diagram to the left, the temperature sensing rod senses refrigerant temperature after passing through the evaporator. The temperature here is communicated to the refrigerant gas inside the diaphragm chamber via the temperature sensing rod.

Therefore, the gas pressure is changed by the temperature which moves the temperature sensing rod that is in direct contact with the diaphragm regulating the opening of the needle valve.

When the temperature of the evaporator outlet is low (when cooling load is small)

The gas pressure in the diaphragm chamber drops and volume decreases causing the temperature sensing rod to move to the right in the diagram and constricting the needle valve.

When the temperature of the evaporator outlet is high (when cooling load is large)

The gas pressure in the diaphragm chamber increases, increasing volume causing the temperature sensing rod to move to the left in the diagram, opening up the needle valve and supplying increased amount of refrigerant to the evaporator.

- (1) Evaporator
- (2) Temperature Sensing Rod
- (3) Diaphragm
- (4) Body
- (5) Spring
- (6) Needle Valve
- (7) Expansion Valve
- (8) AC Unit
- (A) To compressor (low pressure)
- (B) From receiver (high pressure)

9Y1210982CAM0013US0

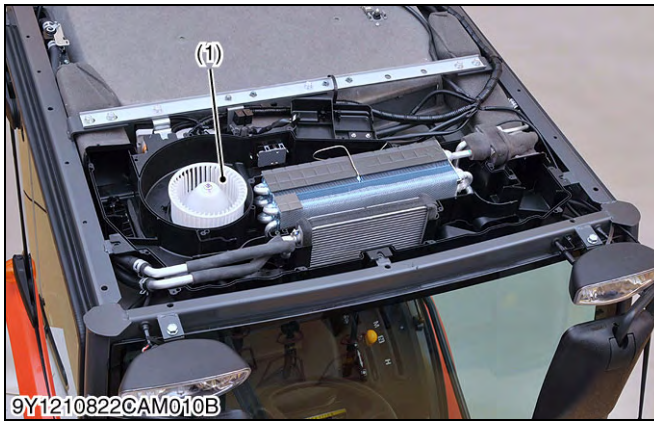

A/C Blower

The blower is incorporated in the left-hand space of the air conditioner unit. It blows cool, warm or fresh air via the dashboard and defroster blow ports into the cabin.

The speed of the blower motor (2) can be adjusted in 4 steps by the resistor (3).

The blower fan (1) is centrifugal type. The air being sucked in parallel with the rotary shaft is blown in the centrifugal direction; in other words, perpendicular to the rotary shaft.

- (1) Blower Fan
- (2) Blower Motor
- (3) Resistor

9Y1210982CAM0011US0

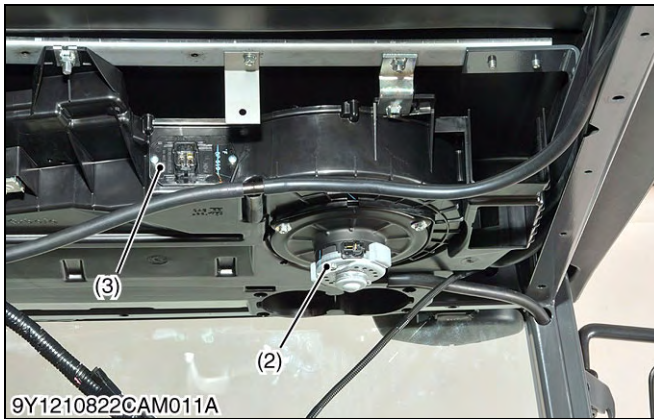

NOTE

- As for the mechanism and function of each component part, refer to "10. CABIN" section in the Workshop Manual of tractor mechanism (Code No. 9Y021-18200).

9Y1210982CAM0012US0

(1) Evaporator

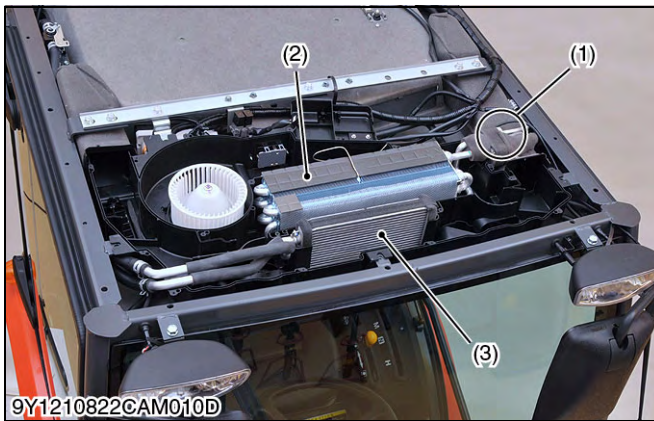

The purpose of the evaporator (2) is just opposite to that of the condenser. The state of refrigerant immediately after the expansion valve is 100 % liquid. As soon as the liquid pressure drops, it starts to boil, and in doing so, absorbs heat. This heat is removed from the air passing over the cooling fins of the evaporator and causes the air to cool.

If too much refrigerant is sent into the evaporator, it will not boil as easily. If the evaporator is filled with liquid refrigerant, it eliminates a place for the refrigerant to properly vaporize. This vaporization is necessary in order to absorb heat. A flooding condition of the evaporator will allow an excess of liquid refrigerant to leave the evaporator and may cause serious damage to the compressor.

If too little refrigerant is sent into the evaporator, again the evaporator will not cool because the refrigerant will vaporize, or boil off, long before it passes through the evaporator.

Refrigerant properly metered into the evaporator should allow for 100 % liquid just after the expansion valve, and 100 % gas at the outlet.

- (1) Expansion Valve
- (2) Evaporator
- (3) Heater Core
- (4) Fin
- (5) Tube

9Y1210982CAM0014US0

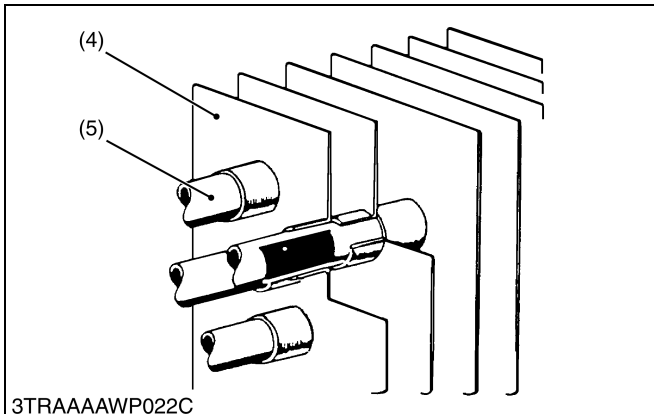

(2) Heater Core

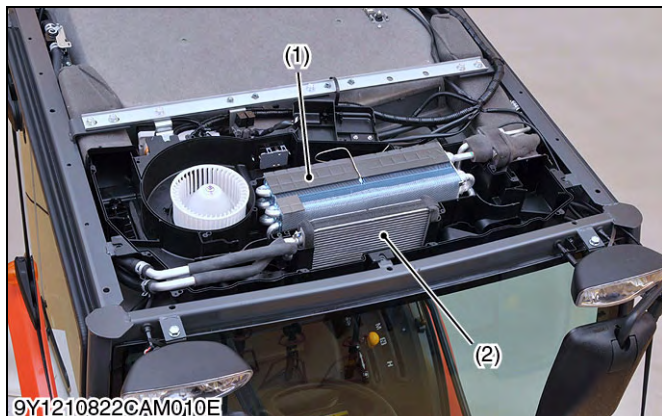

The heater utilizes the heater core to absorb heat from the coolant, which has removed heat from the engine. The inlet port of heater core is connected to the delivery side of the engine water pump by a rubber hose. The water valve is installed on the inlet port of the heater core. Also, the outlet port of the heater core is connected to the engine cylinder block.

The heater core is a heat exchanger, like the evaporator or condenser. Heat is exchanged between heated coolant passing through the core and air in the cabin or fresh outdoor air. The cab air is heated through this process.

(1) Evaporator

(2) Heater Core

9Y1210982CAM0015US0

3. SYSTEM CONTROL

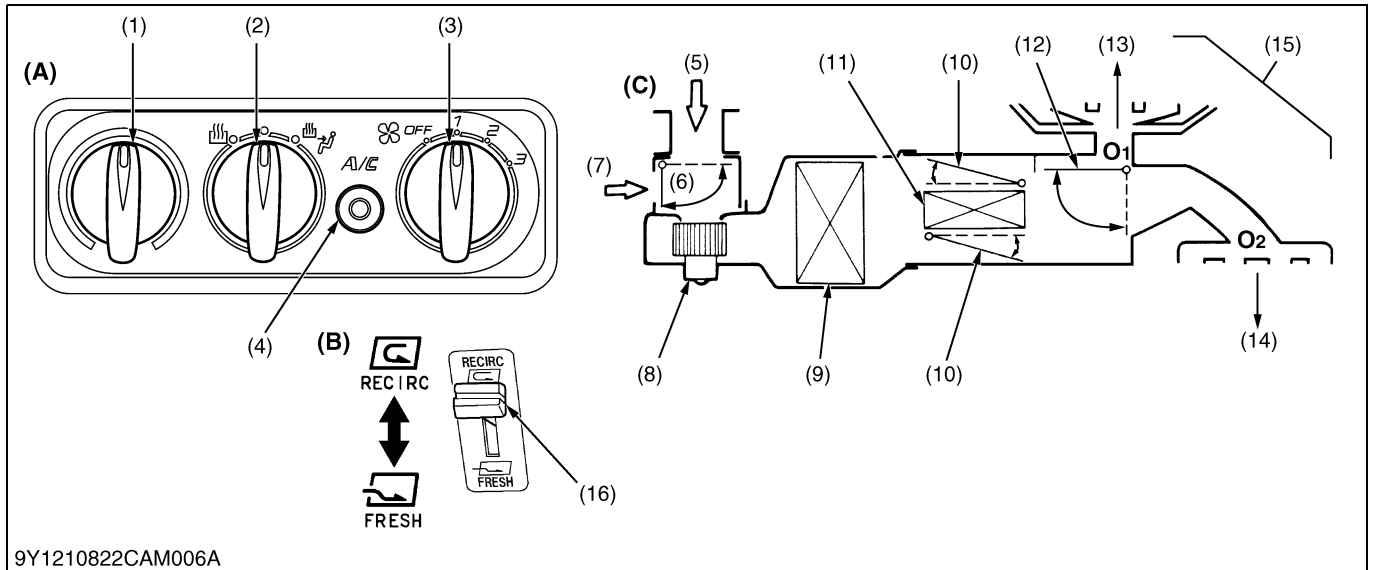

9Y1210822CAM006A

- | | | | |
|---|---|-------------------------------------|---------------------------------------|
| (1) Temperature Control Dial | (7) Recirculated Air | (12) Air Outlet Door D3 (Mode Door) | (A) Control Plate |
| (2) Mode Switch | (8) Blower | (13) DEFOGGER | (B) Air Selection Lever |
| (3) Blow Switch | (9) Evaporator | (14) FACE | (C) Block Diagram of Air Flow Passage |
| (4) Air Conditioner Switch with Indicator Light | (10) Temperature Door D2 (Air Mixed Door) | (15) DEF and FACE | O1: Front air outlet |
| (5) Fresh Air | (11) Heater | (16) Air Selection Lever | O2: Side air outlet |
| (6) Air Intake Door D1 | | | |

1) Selection of recirculated air (7) or fresh air (5) is done with door D1.

■ **RECIRC**

By setting the air selection lever (16) in rear control panel to **RECIRC** position, door **D1** (6) shuts the flesh air inlet port. Air inside the cabin is recirculated.

■ **FRESH**

By moving the air selection lever (16) to **FRESH** position, door **D1** opens the flesh air inlet port. Outside air comes into cabin.

2) Temperature control of outlet air is done with door D2.

■ **COOL**

By setting the temperature control dial (1) in control panel to **COOL** position, door **D2** (10) is moved to close water valve. The air flows to door **D3** (12) side without passing the heater core.

■ **WARM**

By moving the temperature lever to **WARM** position door **D2** is moved to open water valve. The air flows to door **D3** (12) side passing through the heater core.

3) Outlet air flow is controlled by door D3.

Moving the mode switch (2) opens and shuts door **D3** and establishes the air passage according to the lever position.

■ **DEF + FACE**

By moving the mode lever to **DEF + FACE** position, the door **D3** is moved to establish the air passages to outlets "**O1**" and "**O2**". Air comes out from both outlets.

■ **DEF**

Moving the mode lever to **DEF** position, door **D3** is moved to set up the air passage to outlet **O1**. Air comes out from outlet **O1**.

9Y1210982CAM0016US0

4. ELECTRICAL SYSTEM

[1] ELECTRICAL CIRCUIT

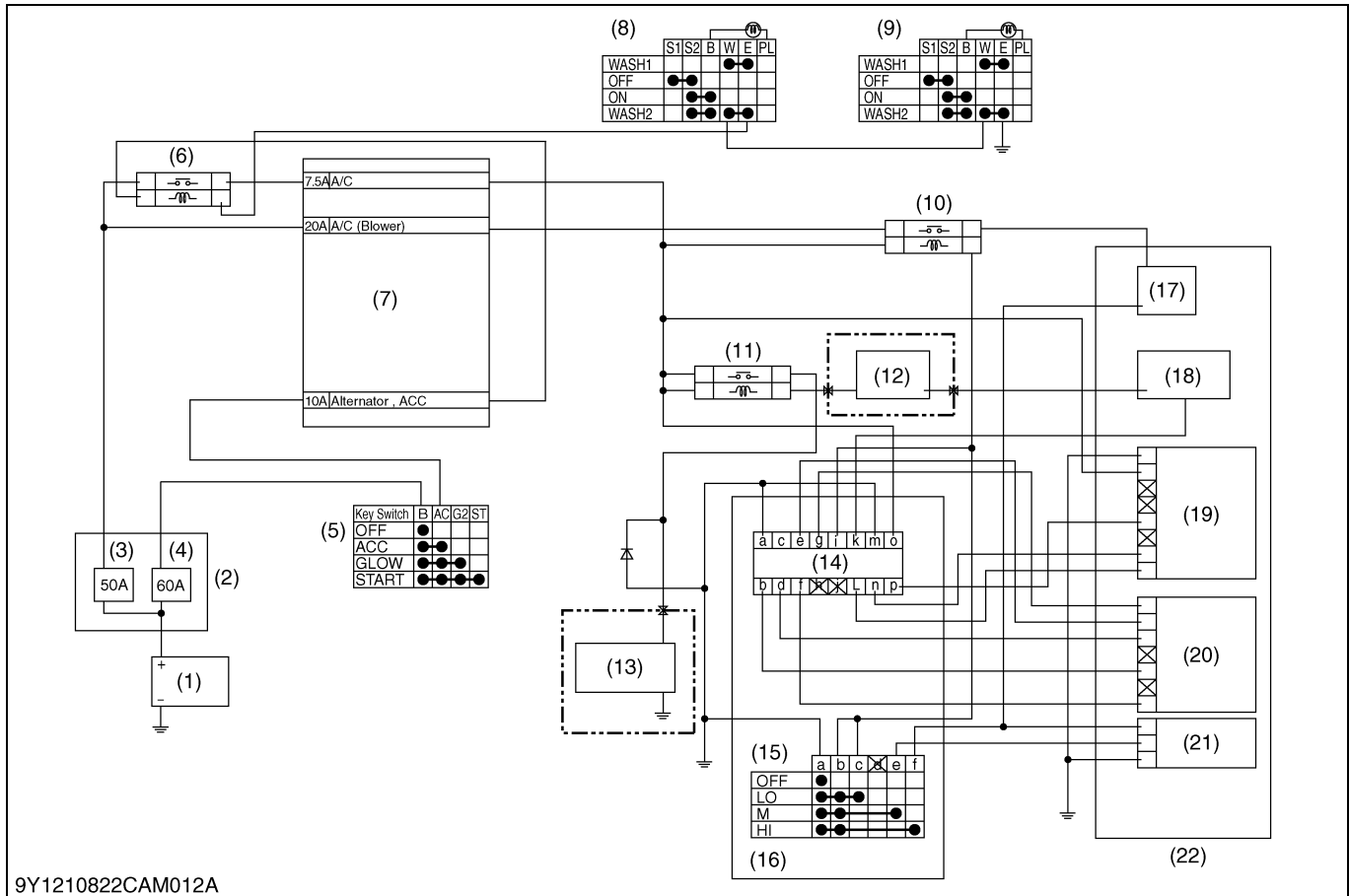

9Y1210822CAM012A

- | | | | |
|--------------------|------------------------|----------------------------|-------------------------------|
| (1) Battery | (7) Fuse | (13) Compressor | (18) Thermostat |
| (2) Slow Blow Fuse | (8) Front Wiper Switch | (14) A/C Control Amplifier | (19) Mode Switch Servo Motor |
| (3) For CABIN Line | (9) Rear Wiper Switch | (15) Blower Switch | (20) Thermostatic Servo Motor |
| (4) For Main Line | (10) Blower Relay | (16) A/C Control Panel | (21) Blower Resistor |
| (5) Main Switch | (11) Compressor Relay | (17) Blower Motor | (22) A/C Unit |
| (6) ACC Relay | (12) Pressure Switch | | |

9Y1210982CAM0017US0

[2] RELAY

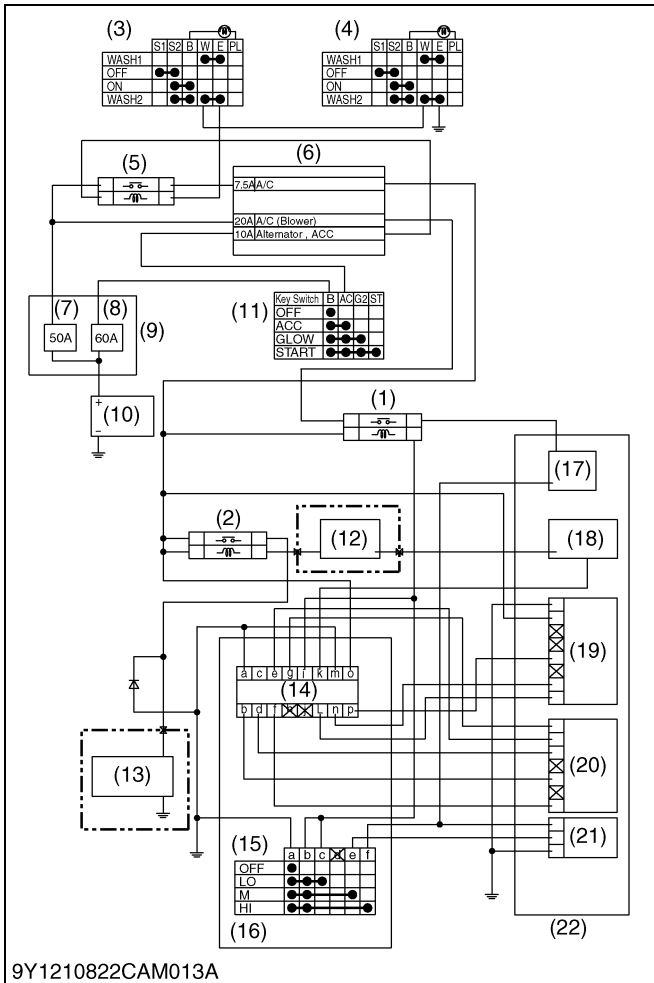
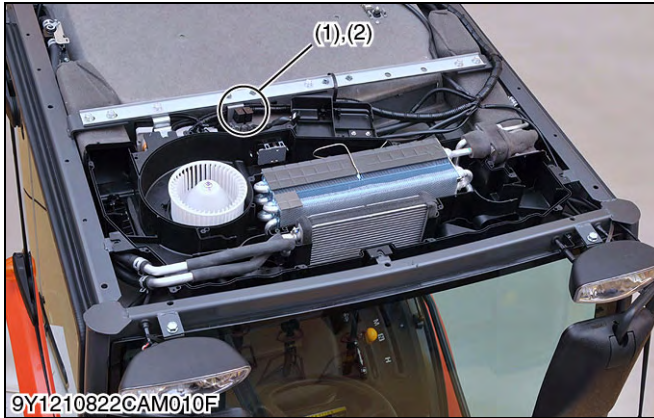

Remove the outer roof and the relays are visible at the ceiling rear of the cabin: blower relay (1) and compressor relay (2). When the blower fan is adjusted for the air flow rate, the blower relay (1) is activated by a signal from the fan switch on the control panel.

Among the air conditioner components, current flows to the blower motor (17) and magnetic clutch. If all of these current were to be passed through the main switch (11) and supplied, the current would be too large for the main switch (11) so that there will be danger or burning out the main switch contact. If the current were to be passed directly from the battery (3), forgetting to turn off the blower motor (7) could result in a discharged battery (10).

To protect against such trouble, relays have been provided. These relays have been made so that when current flows through its coil, the contact close to supply the power from the battery (10). By employing these relays, the current flowing through the main switch (11) has been decreased as only a small current is required to actuate the relay. Thus there will be no danger of burning out the switch contact, and when the main switch (11) is opened, the relay contact will open at the same time. This action stops the current flow in the air conditioner circuit so that there will also be no chance of the battery discharging.

- | | |
|------------------------|-------------------------------|
| (1) Blower Relay | (12) Pressure Switch |
| (2) Compressor Relay | (13) Compressor |
| (3) Front Wiper Switch | (14) A/C Control Amplifier |
| (4) Rear Wiper Switch | (15) Blower Switch |
| (5) ACC Relay | (16) A/C Control Panel |
| (6) Fuse | (17) Blower Motor |
| (7) For CABIN Line | (19) Mode Switch Servo Motor |
| (8) For Main Line | (18) Thermostat |
| (9) Slow Blow Fuse | (20) Thermostatic Servo Motor |
| (10) Battery | (21) Blower Resistor |
| (11) Main Switch | (22) A/C Unit |

9Y1210982CAM0018US0

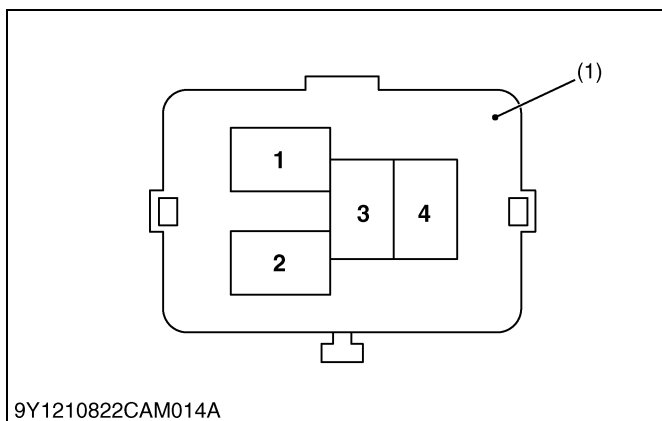

■ Color of wiring

Item	Terminal No.	Color of Wiring
Blower Relay	1	Lg
	2	G/Y
	3	W/B
	4	P/L
Compressor Relay	1	Lg
	2	Y/G
	3	G
	4	Lg

(1) Connector (Wire Harness)

9Y1210982CAM0019US0

SERVICING

CONTENTS

1. TROUBLESHOOTING.....	10-S1
2. SERVICING SPECIFICATIONS.....	10-S5
3. TIGHTENING TORQUES.....	10-S6
4. PRECAUTIONS AT REPAIRING REFRIGERANT CYCLE.....	10-S7
[1] HANDLING OF SERVICE TOOLS.....	10-S9
(1) Manifold Gauge Set.....	10-S9
(2) Refrigerant Charging Hose.....	10-S10
(3) Vacuum Pump Adaptor.....	10-S11
(4) Electric Gas Leak Tester.....	10-S11
(5) Can Tap Valve.....	10-S11
(6) T-joint.....	10-S12
(7) R134a Refrigerant Recovery and Recycling Machine.....	10-S12
5. CHECKING AND CHARGING REFRIGERANT CYCLE.....	10-S13
[1] CHECKING WITH MANIFOLD GAUGE.....	10-S13
[2] DISCHARGING, EVACUATING AND CHARGING.....	10-S17
(1) Discharging the System.....	10-S17
(2) Evacuating the System.....	10-S18
(3) Charging the System.....	10-S19
(4) Checking Charging Refrigerant Amount.....	10-S21
6. CHECKING, DISASSEMBLING AND SERVICING.....	10-S22
[1] CHECKING AND ADJUSTING.....	10-S22
(1) Compressor.....	10-S22
(2) Control Panel (Blower Switch, A/C Switch, Mode Control Dial and Temperature Control Dial).....	10-S23
(3) Blower Resistor.....	10-S25
(4) Blower Motor.....	10-S26
(5) Temperature Motor.....	10-S26
(6) Mode Motor.....	10-S27
(7) Air Conditioner Relay and Blower Relay.....	10-S27
(8) Pressure Switch.....	10-S28
(9) Wiper Switch.....	10-S29
(10)Wiper Motor.....	10-S30
(11)Defogger.....	10-S30
[2] DISASSEMBLING AND ASSEMBLING.....	10-S32
(1) Separating Cabin from Tractor Body.....	10-S32
(2) Removing Compressor Assembly.....	10-S36
(3) Removing Receiver and Condenser.....	10-S38
(4) Removing Air Conditioner Unit.....	10-S38
(5) Removing Air Conditioner Pipes.....	10-S40
(6) Removing Heater Hoses.....	10-S42
(7) Cabin Windshields.....	10-S43
(8) Wiper Motor.....	10-S47
[3] SERVICING.....	10-S48

1. TROUBLESHOOTING

COMPRESSOR

Symptom	Probable Cause and Checking Procedure	Solution	Reference Page
Noisy (Compressor ON)	1. Bearing of compressor worn or damaged	Replace compressor	10-S36
	2. Valves in compressor damaged	Replace compressor	10-S36
	3. Belt slipping	Adjust or replace V-belt	10-S22
	4. Compressor bracket mounting screws loosen	Tighten screws	10-S36
	5. Piping resonant	Tighten or add clamp	10-S41
Noisy (Compressor OFF)	1. Blower damaged	Repair or replace blower	10-S25
	2. Bearings of magnetic clutch, idle pulley or crank pulley worn or damaged	Replace compressor	10-S36

AIR CONDITIONING SYSTEM

Symptom	Probable Cause and Checking Procedure	Solution	Reference Page
Does Not Cool (No Air Flow)	1. Fuse blown	Replace fuse	G-40
	2. A/C compressor relay damaged	Replace relay	9-S11
	3. A/C blower relay damaged	Replace relay	9-S11
	4. A/C blower motor damaged	Replace blower motor	10-S26
	5. A/C blower switch damaged	Replace blower switch	10-S23
	6. Wiring harness disconnected or improperly connected	Repair wiring harness	9-M1 to 9-M3
Does Not Cool (Compressor Does Not Rotate)	1. Fuse blown	Replace fuse	G-40
	2. Magnetic clutch damaged	Repair or replace compressor	10-S36
	3. A/C switch damaged	Replace A/C switch	10-S23
	4. Pressure switch damaged	Replace pressure switch	10-S28
	5. Belt slipping	Adjust or replace V-belt	10-S22
Does Not Cool (Others)	1. Insufficient refrigerant	Check with manifold gauge	10-S13
	2. Expansion valve damaged	Replace expansion valve	10-M8
	3. Compressor damaged	Replace compressor	10-S36
Insufficient Cooling (Insufficient Air Flow)	1. Air filter clogged	Clean or replace air filter	G-32
	2. Evaporator frosted	Clean evaporator	10-M9
	3. A/C blower motor damaged	Replace A/C blower motor	10-S26
	4. A/C blower resistor damaged	Replace A/C blower resistor	10-S25

Symptom	Probable Cause and Checking Procedure	Solution	Reference Page
Insufficient Cooling (Many Bubbles in Sight Glass)	1. Insufficient refrigerant	Check with manifold gauge	10-S13
	2. Gas leaking from some place in refrigerating cycle	Repair and charge refrigerant	10-S21
	3. Air mixed in	Check with manifold gauge	10-S13
Insufficient Cooling (No Bubbles in Sight Glass)	1. Too much refrigerant	Check with manifold gauge	10-S13
Insufficient Cooling (Compressor Does Not Rotate Properly)	1. Belt slipping	Adjust or replace V-belt	10-S22
	2. Magnetic clutch damaged	Repair or replace compressor	10-S36
	3. Compressor damaged	Replace compressor	10-S36
Insufficient Cooling (Others)	1. Temperature motor damaged	Replace temperature motor	10-S26
	2. Water valve damaged	Replace water valve	10-M1
	3. Condenser fin clogged with dust	Clean condenser fin	G-16
	4. Expansion valve damaged	Replace expansion valve	10-M8
Insufficient Heating	1. Water valve damaged	Replace water valve	10-M1
	2. Temperature motor damaged	Check and repair temperature motor	10-S26
	3. Insufficient coolant	Fill coolant	G-37
Too Low Air Flow Rate (Blower Motor Does Not Run)	1. Blower switch damaged	Check and repair blower switch	10-S23
	2. A/C compressor relay damaged	Replace compressor	10-S36
	3. Brush in poor contact	Replace compressor	10-S36
	4. Fuse blown out	Replace fuse	G-40
	5. Wrong wiring or loose connections	Check and repair wiring	9-M1 to 9-M3
Too Low Air Flow Rate (Flow Rate Does Not Change in 3 Steps)	1. Blower resistor damaged	Replace blower	10-S26
	2. Relay damaged	Replace relay	9-S11
	3. Blower switch damaged	Replace blower switch	10-S23
Too Low Air Flow Rate (Others)	1. Blower is not tightened enough	Check and repair blower	10-S26
	2. Blower deformed	Replace blower	10-S26
	3. Blower in contact with casing	Check and repair blower	10-S26
	4. Obstacle at or near suction port	Check and repair suction port	–
	5. Evaporator frosted	Clean or replace evaporator	10-M9
	6. Filter clogged	Clean or replace filter	G-32
	7. Blow duct clogged or missing	Check and repair blow duct	–

Symptom	Probable Cause and Checking Procedure	Solution	Reference Page
Insufficient Cooling (Compressor Magnetic Clutch Does Not Work)	1. Low battery voltage	Charge battery	9-S10
	2. Rotor in contact with stator	Replace rotor	10-S37
	3. Wrong wiring loose connections	Check and repair wiring	9-M1 to 9-M3
	4. Relay damaged	Replace relay	9-S11
	5. Coil shortage	Replace coil	10-S36
	6. Ground malfunction	Check and repair wiring	9-M1 to 9-M3
	7. Coil burst out	Replace coil	10-S36
Insufficient Cooling (Hi-pressure Level is Too High)	1. Refrigerant overcharged	Check with manifold gauge	10-S13
	2. Condenser clogged with dust and dirt	Clean condenser	G-16
	3. Air mixed	Check with manifold gauge	10-S13
Insufficient Cooling (Hi-pressure Level is Too Low)	1. Refrigerant too short	Check with manifold gauge	10-S13
	2. Compressor discharge valve damaged	Replace compressor	10-S36
	3. Compressor gasket damaged	Replace compressor	10-S36
	4. Low-pressure pipe in trouble (Cracked or clogged)	Replace low-pressure pipe	10-S36
Insufficient Cooling (Low-pressure Level is Too High)	1. Refrigerant overcharged	Check with manifold gauge	10-S13
	2. Expansion valve too open	Replace expansion valve	10-M8
Insufficient Cooling (Low-pressure Level is Too Low)	1. Refrigerant too short	Check with manifold gauge	10-S13
	2. Evaporator frosted	Clean or replace evaporator	10-M9
	3. Low-pressure pipe in trouble (Cracked or clogged)	Replace low-pressure pipe	10-S36
	4. Expansion valve clogged	Replace expansion valve	10-M8
Insufficient Cooling (Both Hi-pressure and Low-pressure Level is Too High)	1. Refrigerant overcharged	Check with manifold gauge	10-S13
Insufficient Cooling (Both Hi-pressure and Low-pressure Level is Too Low)	1. Refrigerant too short	Check with manifold gauge	10-S13
Temperature Cannot be Controlled (Temperature Motor and / or Temperature Control Dial Malfunction)	1. Temperature motor damaged	Replace temperature motor	10-S26
	2. Temperature control dial damaged	Replace heater panel assembly	10-S23
	3. Wiring harness connector disconnected	Repair or replace wiring harness	9-M1 to 9-M3

Symptom	Probable Cause and Checking Procedure	Solution	Reference Page
Temperature Cannot be Controlled (Water Valve Does Not Open Properly)	1. Cable wrongly set	Repair cable	10-S39
	2. Cable disconnected	Repair cable	10-S39
Temperature Cannot be Controlled (Mode Motor and / or Mode Switch Malfunction)	1. Mode motor damaged	Replace heater panel assembly	10-S23
	2. Mode switch damaged	Replace heater panel assembly	10-S23
	3. Wiring harness controller disconnected	Repair or replace wiring harness	9-M1 to 9-M3
Temperature Cannot be Controlled (Heater Hoses Laid is Bad)	1. Heater hose caught	Repair heater hose	10-S43
	2. Heater hose twisted or bent	Repair or replace heater hose	10-S43

WINDSHIELD WIPER

Symptom	Probable Cause and Checking Procedure	Solution	Reference Page
Windshield Wiper Does Not Operate	1. Fuse blown (Short-circuit, burnt component inside motor or other part for operation)	Correct cause and replace fuse	G-40
	2. Wiper motor damaged (Broken armature, worn motor brush or seized motor shaft)	Replace wiper motor	10-S30
	3. Wiper switch damaged	Replace wiper switch	10-S29
	4. Foreign material interrupts movement of link mechanism	Repair linkage	10-S30
	5. Wiper arm seized or rusted	Lubricate or replace wiper arm	10-S30
Windshield Wiper Operating Speed Is Too Low	1. Wiper motor damaged (Short-circuit of motor armature, worn motor brush or seized motor shaft)	Replace wiper motor	10-S30
	2. Low battery voltage	Recharge or replace battery	9-S10
	3. Humming occurs on motor in arm operating cycle due to seized arm shaft	Lubricate or replace wiper motor	10-S30
	4. Wiper switch contact improper	Replace wiper switch	10-S29
Windshield Wiper Does Not Stop Correctly	1. Wiper motor damaged (Contaminated auto-return contacts or improper contact due to foreign matter)	Replace wiper motor	10-S30

9Y1210982CAS0090US0

2. SERVICING SPECIFICATIONS

A/C

Item		Factory Specification	Allowable Limit
Refrigerating Cycle (Refrigerating Cycle is Normal Operating)	Pressure (LO Pressure Side)	0.15 to 0.20 MPa 1.5 to 2.0 kgf/cm ² 21 to 28 psi	–
	Pressure (HI Pressure Side)	1.27 to 1.66 MPa 13 to 17 kgf/cm ² 185 to 242 psi	–
Air-gap of A/C Compressor Magnet Clutch	Air gap	0.30 to 0.65 mm 0.012 to 0.025 in.	–
Air Conditioner Drive Belt	Tension	10 to 12 mm (0.39 to 0.47 in.) deflection at 98 N (10 kgf, 22 lbf) of force	–
Pressure Switch (Dual Type) (When pressure switch is turned OFF)	Setting Pressure (LO Pressure Side)	Less than approx. 0.196 MPa 2.0 kgf/cm ² 28.4 psi	–
	Setting Pressure (HI Pressure Side)	More than approx. 3.14 MPa 32 kgf/cm ² 455 psi	–

ELECTRICAL PARTS

Item		Factory Specification	Allowable Limit
Stator Coil	Resistance 1P Connector	3.0 to 4.0 Ω	–
A/C Blower Switch Connector	Voltage a Terminal – b Terminal	Approx. battery voltage	–
A/C Blower Resister	Resistance R1 Terminal – E Terminal	Approx. 0.56 Ω	–
	Resistance R2 Terminal – E Terminal	Approx. 1.56 Ω	–
Front Wiper Switch Connector	Voltage W Terminal – Chassis	Approx. battery voltage	–

9Y1210982CAS0002US0

3. TIGHTENING TORQUES

Tightening torques of screws, bolts and nuts on the table below are especially specified.
(For general use screws, bolts and nuts: See page G-10.)

Item	N·m	kgf·m	lbf·ft
Rear wheel mounting nut [B3150]	167 to 191	17 to 19.5	123 to 141
Rear wheel mounting screw [B3150]	196 to 225	20 to 23	145 to 166
Rear wheel mounting nut and screw [B2650, B2350, B2050]	108 to 126	11.1 to 12.8	79.7 to 92.9
Universal joint mounting bolt	24 to 28	2.5 to 2.8	18 to 20
Cabin mounting bolt and nuts	124 to 150	12.7 to 15.2	91.5 to 110
High pressure pipe and low pressure pipe mounting screw	7.90 to 11.8	0.806 to 1.20	5.83 to 9 80
Compressor mounting screws	24.5 to 29.4	2.50 to 2.99	18.1 to 21.6
Magnetic clutch mounting screw	15 to 21	1.5 to 2.1	11 to 15
High pressure hose 1 mounting screw (condenser side)	4.0 to 6.8	0.41 to 0.69	3.0 to 5.0
High pressure hose 2 retaining nut (receiver side)	4.0 to 6.8	0.41 to 0.69	3.0 to 5.0
Outer roof mounting screw	3.5 to 4.0	0.36 to 0.40	2.6 to 2.9
A/C unit mounting screw (M6)	4.0 to 6.8	0.41 to 0.69	3.0 to 5.0
A/C unit mounting screw (M8)	9.81 to 11.6	1.00 to 1.19	7.24 to 8.60
Low pressure pipe (Cooler pipe (suction)) retaining nut	7.90 to 11.8	0.806 to 1.20	5.83 to 8.70
High pressure pipe (Cooler pipe (liquid)) retaining nut	11.8 to 14.7	1.21 to 1.49	8.71 to 10.8
Low pressure hose mounting screw (compressor side)	7.9 to 11.8	0.81 to 1.20	5.9 to 8.70
High pressure hose 1 mounting screw (compressor side)	7.9 to 11.8	0.81 to 1.20	5.9 to 8.70
High pressure hose 1 mounting screw (condenser side)	4.0 to 6.8	0.41 to 0.69	3.0 to 5.0
High pressure hose 2 retaining nut (receiver side)	4.0 to 6.8	0.41 to 0.69	3.0 to 5.0
High pressure pipe 2 retaining nut	7.90 to 11.8	0.806 to 1.20	5.83 to 8.70
Low pressure pipe retaining nut	7.90 to 11.8	0.806 to 1.20	5.83 to 8.70
Wiper motor mounting nut	6.4 to 9.3	0.65 to 0.95	4.7 to 6.8
Wiper arm mounting nut	7.9 to 9.8	0.80 to 1.0	5.8 to 7.2
Wiper motor mounting screw	7.9 to 9.8	0.80 to 1.0	5.8 to 7.2

9Y1210982CAS0003US0

4. PRECAUTIONS AT REPAIRING REFRIGERANT CYCLE

When checking or repairing the air conditioning system, the following precautions and rules must be observed. And it is of first importance that no other personnel than a well-trained serviceman should be allowed to handle the refrigerant.



CAUTION

- Since direct contact of the liquid refrigerant with your skin will cause frostbite, always be careful when handling the refrigerant. Always wear goggles to protect your eyes when working around the system.
- The refrigerant service container has a safe strength. However, if handled incorrectly, it will explode. Therefore, always follow the instructions on the label. In particular, never heat the refrigerant container above 40 °C (104 °F) or drop it from a high height.
- Do not steam clean on the system, especially condenser since excessively high pressure will build up in the system, resulting in explosion of the system.
- If you improperly connect the hose between the service valve of compressor and gauge manifold, or incorrectly handle the valves, the refrigerant service container or charging hose will explode. When connecting the hose or handling the valve, be sure to check the high pressure side or low pressure side.
- In case the refrigerant is charged while the compressor is operated, do not open the high pressure valve of the gauge manifold.
- Be careful of the toxicity of the gas. The gas is harmless and nontoxic in its original state, however it produces a toxic substance when it comes in contact with high temperature parts and decomposes.
- Do not heat the service can unless necessary. When it has to be heated, use warm water of 40 °C (104 °F) or lower. Do not heat using boiling water.

■ IMPORTANT

- If the refrigerant, O-rings, etc. for R12 are used in the R134a air conditioner system, problems such as refrigerant leakage or cloudiness in the sight glass may occur. Therefore, in order to prevent charging of refrigerant or erroneous connections, the shapes of the piping joint as well as the shapes of the service valve and the service tools have been changed.
- Always keep the working place clean and dry and free from dirt and dust. Wipe off water from the line fittings with a clean cloth before disconnecting.
- Use only for R134a refrigerant service tool.
- Use for R134a refrigerant recovery and recycling machine when discharging the refrigerant.
- Before attaching the charging hose to the can tap valve of the refrigerant container, check each packing for clogging.
- When disconnecting the charging hose from the charging valve of compressor and receiver, remove it as quick as possible so that gas leakage can be minimized.
- Be sure to charge the specified amount of refrigerant, but not excessively. Over-charging of the refrigerant in particular may cause insufficient cooling, etc..
- Since the charging hose can be connected to can tap valve by hand, do not use a pliers for tightening it.
- Keep refrigerant containers in a cool and dark place avoiding such place which are subject to strong sunlight or high temperature.
- R134a compressor oil absorbs moisture easily, so that be sure to seal after disconnecting the each parts.
- Do not use old-type refrigerant R12 or compressor oil for old-type refrigerant.
- When replacing the condenser, evaporator and receiver, etc., fill the compressor oil to compressor according to the table below.

(To be continued)

(Continued)**(Refrigerant)**

Kinds of refrigerant (Charge amount)	Factory specification	R134a 650 to 710 g 1.44 to 1.56 lbs
---	-----------------------	---

(Compressor Oil)

Quantity (Total)	Brand Name
110 to 120 cc 0.116 to 0.126 U.S.qts 0.0968 to 0.105 Imp.qts	ND-OIL 8 <PAG* oil>

*PAG: Polyalkyleneglycol (Synthetic oil)

(Reference)

Replacing Parts	Fill Quantity	Brand Name
Condenser	20 cc 0.021 U.S.qts 0.018 Imp.qts	ND-OIL 8 <PAG* oil>
Evaporator	10 cc 0.011 U.S.qts 0.0088 Imp.qts	
Receiver	10 cc 0.011 U.S.qts 0.0088 Imp.qts	
Hose	10 cc 0.011 U.S.qts 0.0088 Imp.qts	

*PAG: Polyalkyleneglycol (Synthetic oil)

9Y1210982CAS0005US0

[1] HANDLING OF SERVICE TOOLS

(1) Manifold Gauge Set

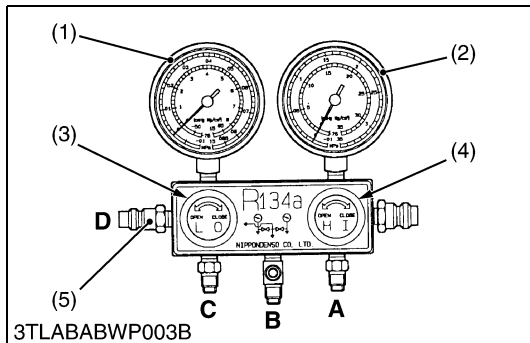

The hand valves on the manifold gauge set are used to open and close the valve. The hand valve inscribed **LO** is for the low pressure side valve (3) and **HI** is for the high pressure side valve (4). By opening or closing the high and low pressure hand valves, the following circuits are established.

- | | |
|-----------------------------------|-----------------------------------|
| (1) LO Pressure Gauge | (4) HI Pressure Side Valve |
| (2) HI Pressure Gauge | (5) Schrader Valve |
| (3) LO Pressure Side Valve | |

9Y1210982CAS0006US0

When LO Pressure Side Valve and HI Pressure Side Valve are Closed

Two circuits are established.
 Port (C) → **LO** pressure gauge (1)
 Port (A) → **HI** pressure gauge (2)

■ **NOTE**

- **Schrader valve (D) must be opened.**

- | | |
|------------------------------|------------------------------|
| (1) LO Pressure Gauge | (2) HI Pressure Gauge |
|------------------------------|------------------------------|

9Y1210982CAS0007US0

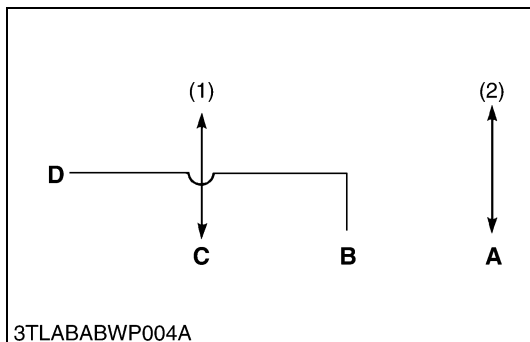

When LO Valve is Opened and HI Valve is Closed

Two circuits are established.
 Port (C) → **LO** pressure gauge (1)
 → Port (B)
 → Port (D)
 Port (A) → **HI** pressure gauge (2)

■ **NOTE**

- **Schrader valve (D) must be opened.**

- | | |
|------------------------------|------------------------------|
| (1) LO Pressure Gauge | (2) HI Pressure Gauge |
|------------------------------|------------------------------|

9Y1210982CAS0008US0

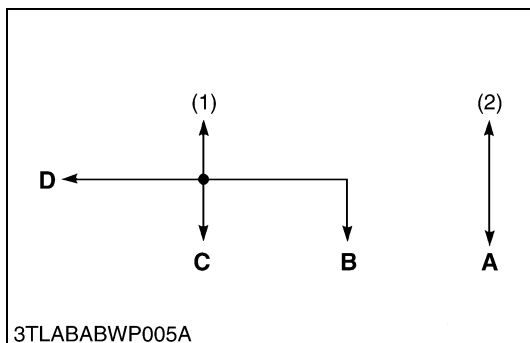

When LO Valve is Closed and HI Valve is Opened

Two circuits are established.
 Port (C) → **HI** pressure gauge (2)
 → Port (B)
 → Port (D) (Schrader valve must be opened)
 Port (A) → **LO** pressure gauge (1)

■ **NOTE**

- **Schrader valve (D) must be opened.**

- | | |
|------------------------------|------------------------------|
| (1) LO Pressure Gauge | (2) HI Pressure Gauge |
|------------------------------|------------------------------|

9Y1210982CAS0009US0

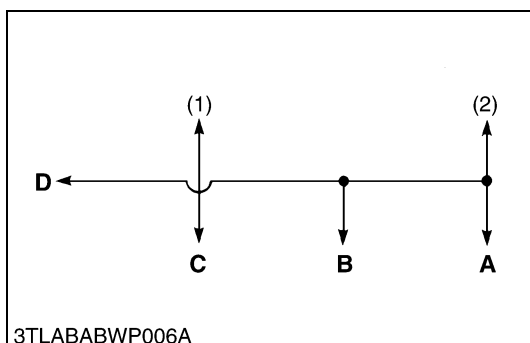

When LO and HI Valve is Opened

Two circuits are established.
 Port (A) → **HI** pressure gauge (2)
 → **LO** pressure gauge (1)
 → Port (B)
 → Port (C)
 → Port (D) (Schrader valve must be opened)

■ **NOTE**

- **Schrader valve (D) must be opened.**

- | | |
|------------------------------|------------------------------|
| (1) LO Pressure Gauge | (2) HI Pressure Gauge |
|------------------------------|------------------------------|

9Y1210982CAS0010US0

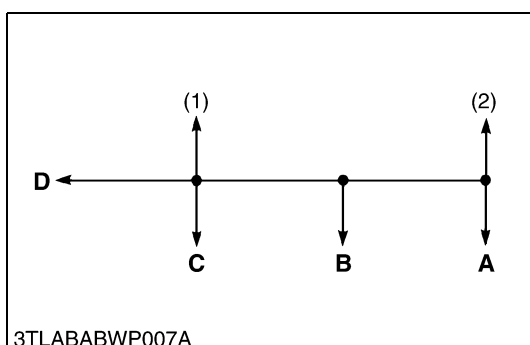

(2) Refrigerant Charging Hose

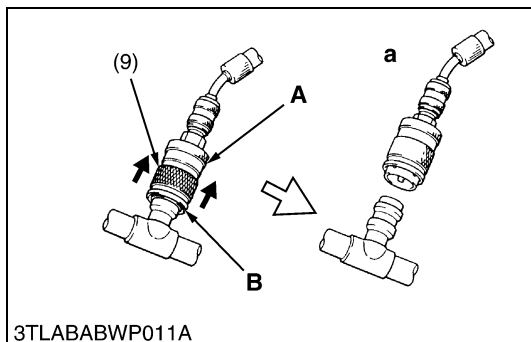
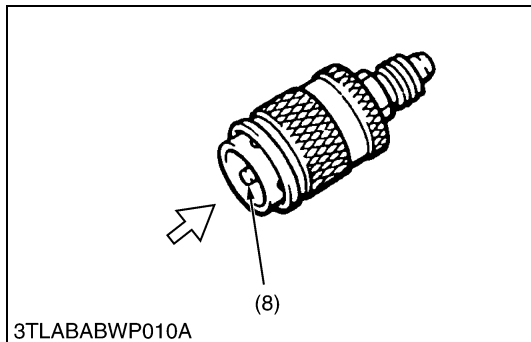
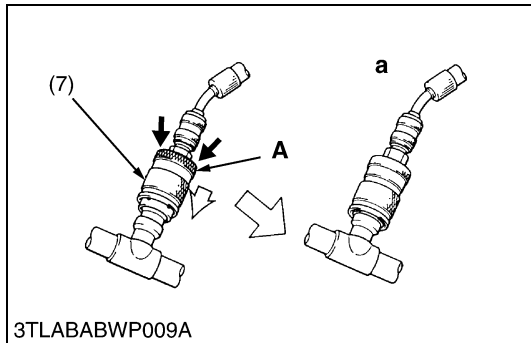
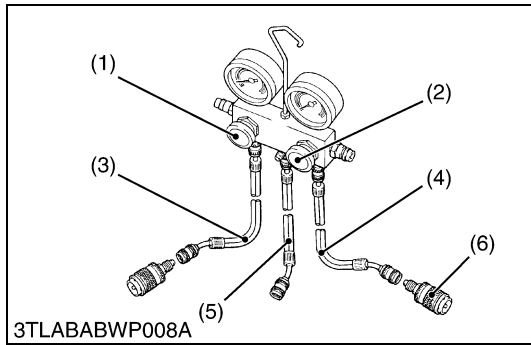

The charging hoses are classified into three colors. Each charging hose must be handled as follows:

- The air conditioner manufacture recommends that the blue hose (3) is used for the **LO** pressure side (suction side), the green hose (5) for refrigeration side (center connecting port) and the red hose (4) for **HI** pressure side (discharged side).

(When connecting)

- Push the quick disconnect adaptor (6) into the charging valve, and push on part **A** until a click is heard.

■ NOTE

- When connecting, push carefully so the pipe doesn't bend.
- When connecting the quick disconnect connector, should the sleeve (7) move before the quick link connector can be connected to the charging valve, move the quick sleeve to its original position and try again.
- When some refrigerant remains in the charging hose at the time of connections, it may be difficult to connect the quick link connector. In this case, perform the operation after removing any residual pressure in the hose. (Remove the residual pressure by pushing the pusher (8).)

(When reassembling)

- While holding on to part **A** of the quick disconnect adaptor, slide part **B** up.

■ NOTE

- After removing the adaptor, ensure to cap the quick disconnect adaptor service valve.

- | | |
|------------------------------|-----------------|
| (1) LO Pressure Side Valve | (7) Sleeve |
| (2) HI Pressure Side Valve | (8) Pusher |
| (3) Blue Hose | (9) Sleeve |
| (4) Red Hose | |
| (5) Green Hose | a: CLICK |
| (6) Quick Disconnect Adaptor | |

9Y1210982CAS0011US0

(3) Vacuum Pump Adaptor

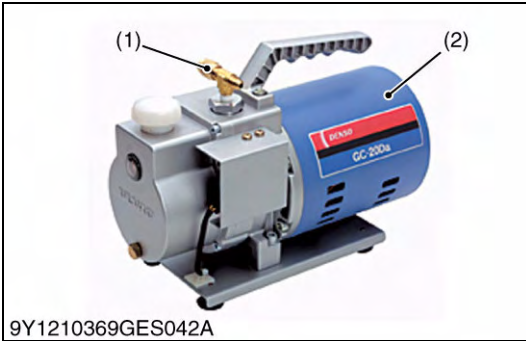

9Y1210369GES042A

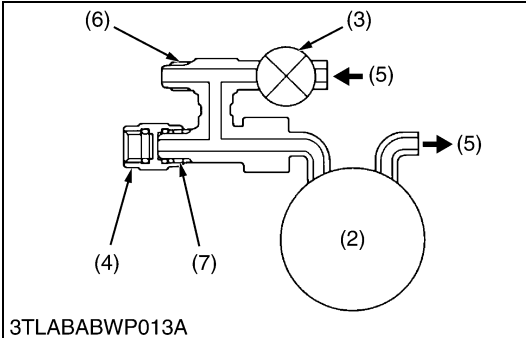

3TLABABWP013A

Objective of the Vacuum Pump Adaptor

1. After vacuum has been created in the air conditioning cycle, when the vacuum pump is stopped, since there is vacuum in hoses within the gauge manifold, the vacuum pump oil flows back into the charging hose. If the refrigerant is refilled with the system still in this state, the vacuum pump oil left in the charging hose enters the air conditioner cycle together with the refrigerant. Vacuum pump adaptor with a solenoid valve is used to prevent this back-flow of oil from the vacuum pump. The role of the solenoid valve is that when the current passes through the solenoid valve, the valve closes to keep out the outside air and allow the vacuum to build up, but when the current stops, the valve opens to allow in air and end the vacuum.
2. Attaching this adaptor to the R12 vacuum pump currently being used allows the pump to be used with both R134a and R12.

- | | |
|-------------------------|---------------|
| (1) Vacuum Pump Adaptor | (5) Air |
| (2) Vacuum Pump | (6) For R134a |
| (3) Magnetic Valve | (7) For R12 |
| (4) Blind Cap | |

9Y1210982CAS0012US0

(4) Electric Gas Leak Tester

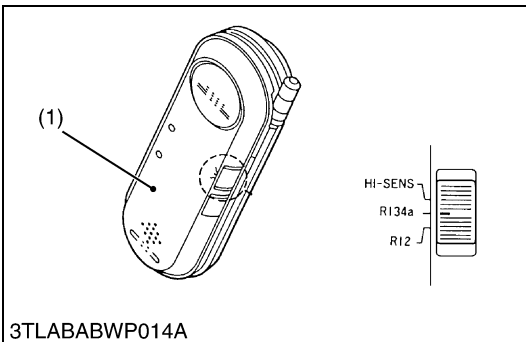

3TLABABWP014A

The current R12 gas leak tester has poor sensitivity for R134a and cannot be used. Therefore, a new electric gas leak tester with greater sensitivity has been designed and can be used with both R134a and R12.

(Reference)

- Leak tester with halide torch
 - Since the reaction with chlorine within the refrigerant is used to detect gas leaks, R134a, which contains no chlorine, cannot be detected.

- (1) Electric Gas Leak Tester

9Y1210982CAS0013US0

(5) Can Tap Valve

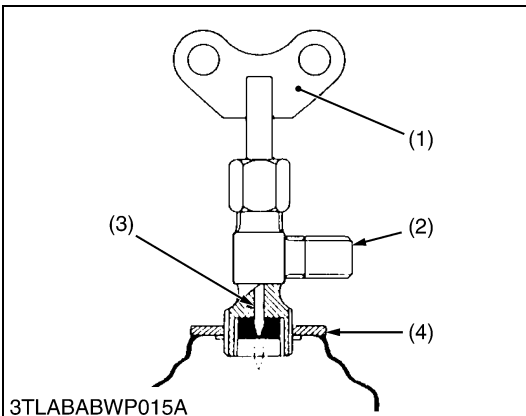

3TLABABWP015A

The can tap valve that is used to charge the refrigerant into the air conditioning system, should be used as follows:

1. Before putting the can tap valve on the refrigerant container, turn the handle (1) counterclockwise till the valve needle is fully retracted.
2. Turn the plate nut (disc) (4) counterclockwise till it reaches its highest position, then screw down the can tap valve into the sealed tap.
3. Turn the place nut clockwise fully, and fix the center charging hose to the valve.
4. Tighten the place nut firmly by hand.
5. Turn the handle (1) clockwise, thus making a hole in the sealed tap.
6. To charge the refrigerant into the system, turn the handle (1) counterclockwise. To stop charging, turn it clockwise.

- | | |
|----------------------|------------|
| (1) Butterfly Handle | (3) Needle |
| (2) Connection | (4) Disc |

9Y1210982CAS0014US0

(6) T-joint

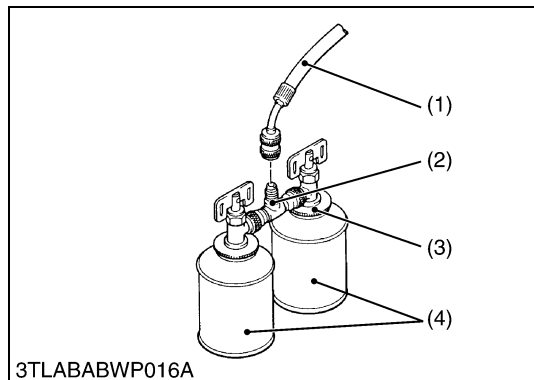

T-joint (2) is used to increase efficiency of gas charging using two refrigerant containers (4) at a time.

1. Install two refrigerant container service valves to T-joint (2) sides and connect the charging hose (1) to it.

- | | |
|---------------------------|---------------------------|
| (1) Charging Hose (Green) | (3) Can Tap Valve |
| (2) T-joint | (4) Refrigerant Container |

9Y1210982CAS0015US0

(7) R134a Refrigerant Recovery and Recycling Machine

When there is necessity of discharging the refrigerant on repairing the tractor, it should use recovery and recycling machine. (Don't release the refrigerant into the atmosphere.)

■ IMPORTANT

- Use only R134a refrigerant recovery and recycling machine, eliminate mixing R134a equipment, refrigerant and refrigerant oils with R12 systems to prevent compressor damage.

9Y1210982CAS0016US0

5. CHECKING AND CHARGING REFRIGERANT CYCLE

[1] CHECKING WITH MANIFOLD GAUGE

■ IMPORTANT

- The gauge indications described in the following testing are those taken under the same condition, so it should be noted that the gauge readings will differ somewhat with the ambient conditions.

Condition

- Ambient temperature: 30 to 35 °C (86 to 95 °F)
- Engine speed: Approx. 1500 min⁻¹ (rpm)
- Temperature control lever: Maximum cooling position
- Air-Conditioner switch: **ON**
- Blower switch: **HI** position

9Y1210982CAS0017US0

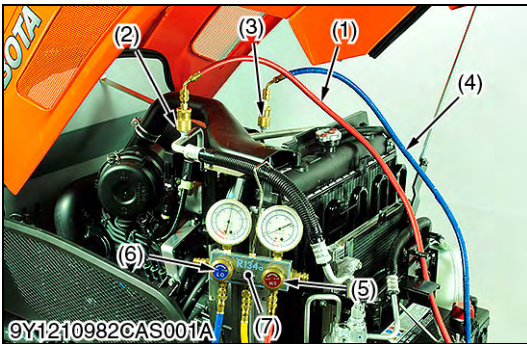

Manifold Gauge Connecting and Test Preparation

1. Close the manifold gauge **HI** and **LO** pressure side valve (5), (6) tightly.
2. Connect the charging hose (1) (red) to the **HI** pressure side charging valve (2) and connect the charging hose (4) (blue) to the **LO** pressure side charging valve (3).

■ NOTE

- Be sure to drive out the air in the charging hoses at the manifold gauge connection end by utilizing the refrigerant pressure in the refrigerating cycle.
3. Start the engine and set at approx. 1500 min⁻¹ (rpm).
 4. Turn on the A/C switch and set the temperature control lever to **maximum cooling** position.
 5. Set the blower switch to **HI** position.

- (1) Charging Hose (Red)
- (2) **HI** Pressure Side Charging Valve
- (3) **LO** Pressure Side Charging Valve
- (4) Charging Hose (Blue)
- (5) **HI** Pressure Side Valve
- (6) **LO** Pressure Side Valve
- (7) Manifold Gauge

9Y1210982CAS0018US0

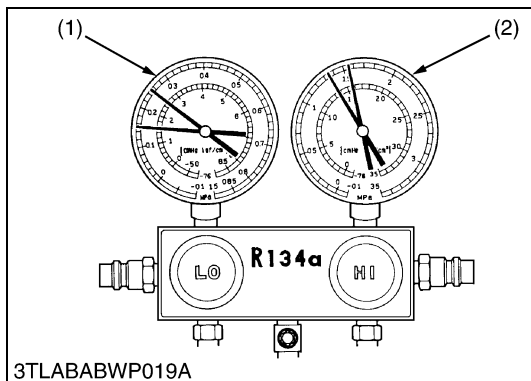

Normal Operating

If the refrigerating cycle is operating normally, the reading at the **LO** pressure side (1) should be generally by around 0.15 to 0.2 MPa (1.5 to 2.0 kgf/cm², 21 to 28 psi) and that at the **HI** pressure side (2) around 1.27 to 1.66 MPa (13 to 17 kgf/cm², 185 to 242 psi).

Gas pressure	Factory specification	Low pressure side	0.15 to 0.20 MPa 1.5 to 2.0 kgf/cm ² 21 to 28 psi
		High pressure side	1.27 to 1.66 MPa 13 to 17 kgf/cm ² 185 to 242 psi

- (1) **LO** Pressure Side
- (2) **HI** Pressure Side

9Y1210982CAS0019US0

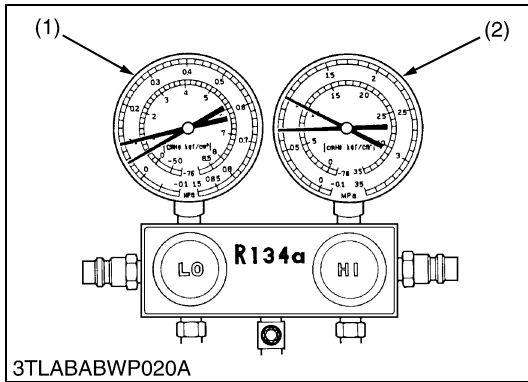

Insufficient Refrigerant

- Symptoms seen in refrigerating cycle
 - Both **LO** and **HI** pressure side (1), (2) pressures too low.
 - LO** pressure side (1): 0.05 to 0.1 MPa (0.5 to 1.0 kgf/cm², 7.1 to 14.2 psi)
 - HI** pressure side (2): 0.69 to 0.98 MPa (7 to 10 kgf/cm², 99.6 to 142.2 psi)
 - Bubbles seen in sight glass.
 - Air discharged from air conditioner slightly cold.
- Probable cause
 - Gas leaking from some place in refrigerant cycle.
- Solution
 - Check for leakage with electric gas leak tester and repair.
 - Recharge refrigerant to the proper level. (See page 10-S19.)

(1) **LO** Pressure Side(2) **HI** Pressure Side

9Y1210982CAS0020US0

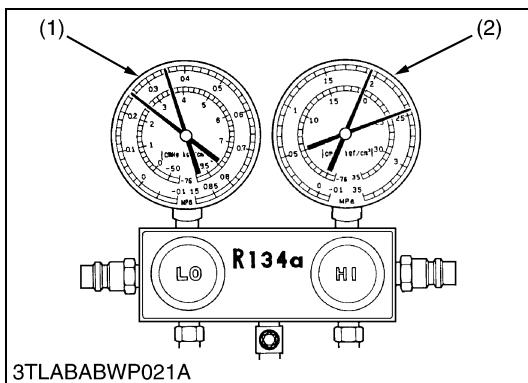

Excessive Refrigerant or Insufficient Condenser Cooling

- Symptoms seen in refrigerating cycle
 - Both **LO** and **HI** pressure side (1), (2) pressures too high.
 - LO** pressure side (1): 0.20 to 0.35 MPa (2.0 to 3.5 kgf/cm², 28.4 to 49.8 psi)
 - HI** pressure side (2): 1.96 to 2.45 MPa (20 to 25 kgf/cm², 284.5 to 355.6 psi)
- Probable cause
 - Overcharging refrigerant into cycle.
 - Condenser cooling damaged.
- Solution
 - Clean condenser. (See page G-33.)
 - Adjust air conditioner belt to proper tension. (See page 1-S25.)
 - If the above two items are in normal condition, check refrigerant quantity. (See page G-42.)

■ NOTE

- If excessive refrigerant is to be discharged, loosen manifold gauge **LO** pressure side valve and vent out slowly.

(1) **LO** Pressure Side(2) **HI** Pressure Side

9Y1210982CAS0021US0

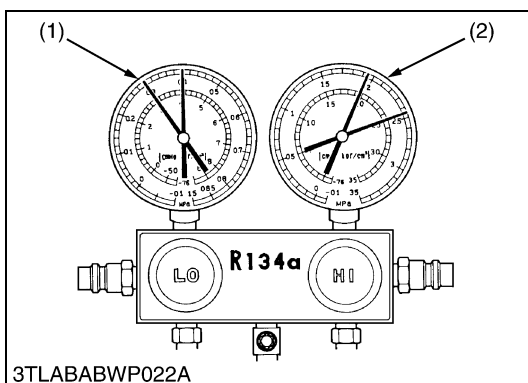

Air Entered in the Cycle

- Symptoms seen in refrigerating cycle
 - Both **LO** and **HI** pressure side (1), (2) pressures too high.
 - LO** pressure side (1): 0.20 to 0.35 MPa (2.0 to 3.5 kgf/cm², 28.4 to 49.8 psi)
 - HI** pressure side (2): 1.96 to 2.45 MPa (20 to 25 kgf/cm², 284.5 to 355.6 psi)
 - LO** pressure side (1) piping not cold when touched.
- Probable cause
 - Air entered in refrigerating cycle.
- Solution
 - Replace receiver.
 - Check compressor oil contamination and quantity.
 - Evacuate and recharge new refrigerant. (See page 10-S19.)

■ NOTE

- The above cycle can be seen when the cycle is charged without evacuation.

(1) **LO** Pressure Side(2) **HI** Pressure Side

9Y1210982CAS0022US0

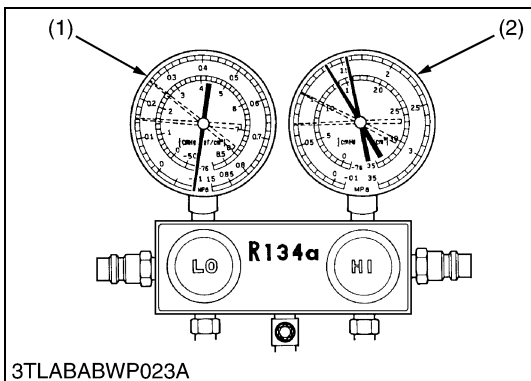

Moisture Entered in the Cycle

1. Symptoms seen in refrigerating cycle
 - The air conditioner operates normally at the beginning, but over time, **LO** pressure side (1) pressure is **vacuum** and **HI** pressure side (2) is low pressure.
 - LO** pressure side (1): Vacuum
 - HI** pressure side (2): 0.69 to 0.98 MPa (7 to 10 kgf/cm², 99.6 to 142.2 psi)
2. Probable cause
 - The moisture in the refrigerating cycle freezes in the expansion valve orifice and causes temporary blocking. After a time, the ice melts and condition returns to normal.
3. Solution
 - Replace receiver.
 - Remove moisture in cycle by means of repeated evacuation.
 - Recharge new refrigerant to the proper level. (See page 10-S19.)

(1) **LO** Pressure Side (2) **HI** Pressure Side

9Y1210982CAS0023US0

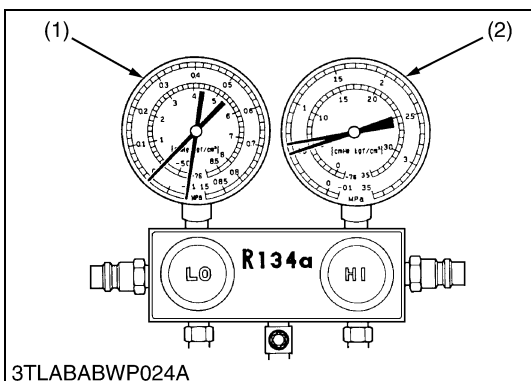

Refrigerant Fails to Circulate

1. Symptoms seen in refrigerating cycle
 - **LO** pressure side (1) pressure is vacuum and, **HI** pressure side (2) is low pressure.
 - LO** pressure side (1): Vacuum
 - HI** pressure side (2): 0.49 to 0.59 MPa (5 to 6 kgf/cm², 71.2 to 85.3 psi)
2. Probable cause
 - Refrigerant flow obstructed by moisture or dirt in the refrigerating cycle freezing or sticking on the expansion valve orifice.
3. Solution
 - Allow to stand for same time and then resume operation to decide whether the plugging is due to moisture or dirt.
 - If caused by moisture, correct by referring to instructions in previous.
 - If caused by dirt, remove the expansion valve and blow out the dirt with compressed air.
 - If unable to remove the dirt, replace the expansion valve. Replace the receiver. Evacuate and charge in proper amount of new refrigerant. (See page 10-S19.)
 - If caused by gas leakage in heat sensitizing tube, replace the expansion valve.

(1) **LO** Pressure Side (2) **HI** Pressure Side

9Y1210982CAS0024US0

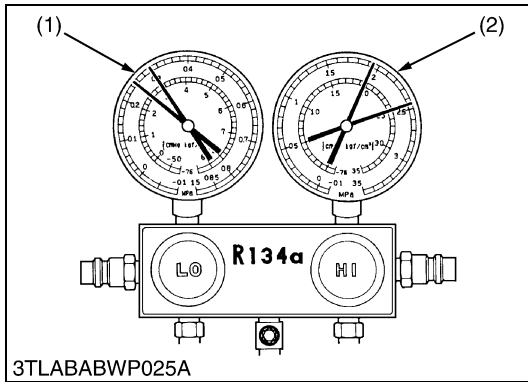

Expansion Valve Opens Too Far or Improper Installation of Heat Sensitizing Tube

- Symptoms seen in refrigerating cycle
 - Both **LO** and **HI** pressure side (1), (2) pressures too high.
 - LO** pressure side (1):
0.29 to 0.39 MPa (3.0 to 4.0 kgf/cm², 42.71 to 56.9 psi)
 - HI** pressure side (2):
1.96 to 2.45 MPa (20 to 25 kgf/cm², 284.5 to 355.6 psi)
 - Frost or heavy dew on low pressure side piping.
- Probable cause
 - Expansion valve trouble or heat sensitizing tube improperly installed.
 - Flow adjustment not properly done.
- Solution
 - Check installed condition of heat sensitizing tube.
 - If installation of heat sensitizing tube is correct, replace the expansion valve.

(1) **LO** Pressure Side(2) **HI** Pressure Side

9Y1210982CAS0025US0

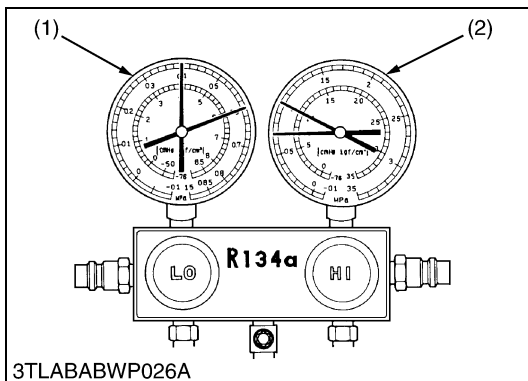

Faulty Compression of Compressor

- Symptoms seen in refrigerating cycle
 - LO** pressure side (1):
0.39 to 0.59 MPa (4 to 6 kgf/cm², 56.9 to 85.3 psi)
 - HI** pressure side (2):
0.69 to 0.98 MPa (7 to 10 kgf/cm², 99.6 to 142.2 psi)
- Probable cause
 - Leak in compressor.
- Solution
 - Replace compressor. (See page 10-S17, 10-S36.)

■ **NOTE**

- Manifold gauge indications (left side figure) at faulty compressing by compressor.**

(1) **LO** Pressure Side(2) **HI** Pressure Side

9Y1210982CAS0026US0

[2] DISCHARGING, EVACUATING AND CHARGING

■ IMPORTANT

- When discharging, evacuating or charging the refrigerating system, be sure to observe the "PRECAUTION AT REPAIRING REFRIGERANT CYCLE".

9Y1210982CAS0027US0

(1) Discharging the System

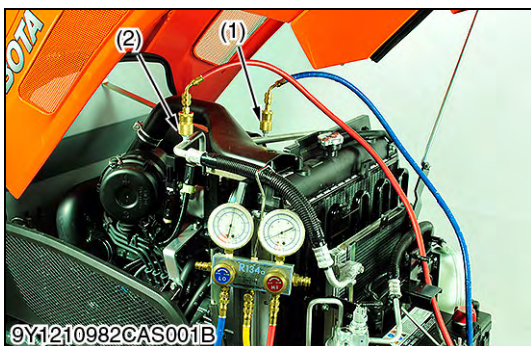
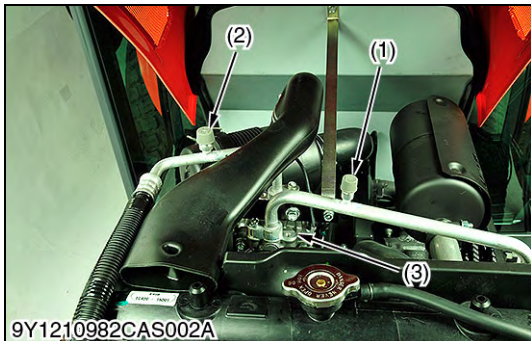

Discharging R134a Refrigerant

Prepare for the R134a refrigerant recovery and recycling machine.

1. Connect low pressure side hose (blue) from the recovery and recycling machine to **LO** pressure side charging valve (1) on the compressor (3). Connect high pressure side hose (red) to **HI** pressure side charging valve (2) on the compressor (3).
2. Follow the manufacturers instructions and discharge the system.

■ IMPORTANT

- Use only R134a refrigerant recovery and recycling machine. Eliminate mixing R134a equipment, refrigerant, and refrigerant oils with R12 systems to prevent compressor damage.



CAUTION

- Protect fingers with cloth against frostbite by refrigerant when disconnecting the hose to the charging valve.

- (1) LO Pressure Side Charging Valve (3) Compressor
 (2) HI Pressure Side Charging Valve

9Y1210982CAS0028US0

(2) Evacuating the System

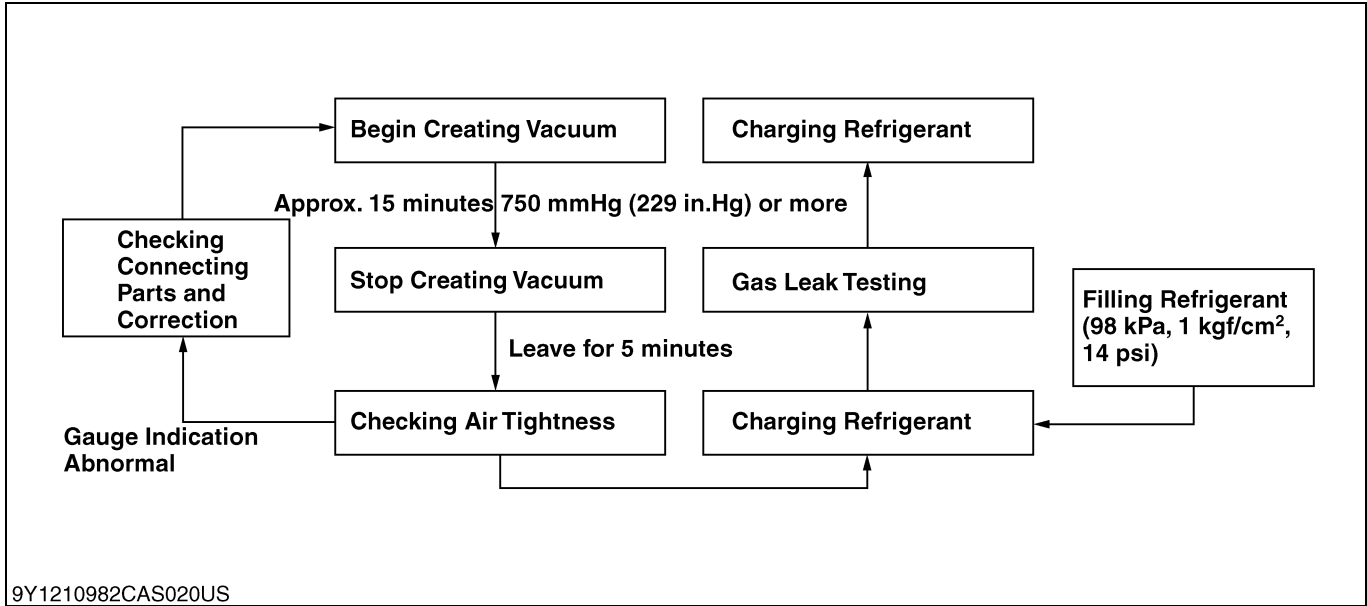

1. Discharge refrigerant from the system by R134a refrigerant recovery and recycling machine. (See page 10-S17.)
2. Connect the charging hose (red) to the **HI** pressure side charging valve and connect the charging hose (blue) to the **LO** pressure side charging valve.
3. Connect the center charging hose (green) to a vacuum pump inlet.
4. Open both valves of manifold gauge fully. Then run the vacuum pump to evacuate the refrigerant cycle. (For approx. 15 minutes.)
5. When **LO** pressure gauge reading is more than 750 mmHg (299 in.Hg), stop the vacuum pump and close both valves of manifold gauge fully.
6. Wait for over 5 minutes with the **HI** and **LO** pressure side valves of gauge manifold closed, and then check that gauge indicator does not return to 0.
7. If the gauge indicator is going to approach to 0, check whether there is a leaking point and repair if it is, and then evacuate it again.

9Y1210982CAS0029US0

(3) Charging the System

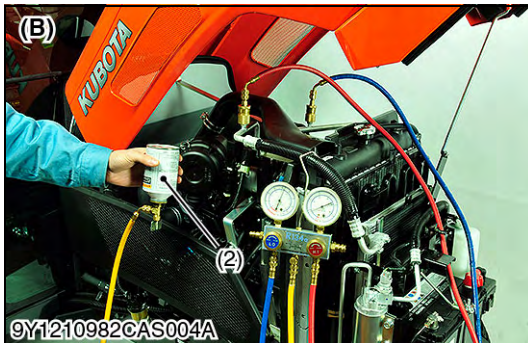
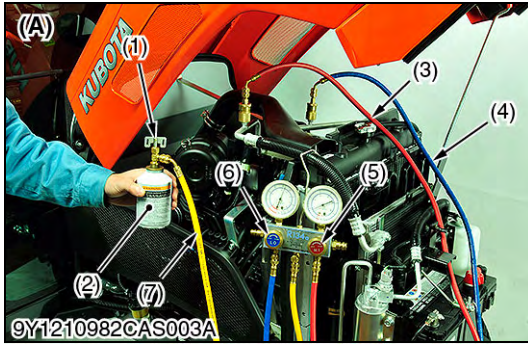

Charging an Empty System (Liquid)

This procedure is for charging an empty system through the **HI** pressure side with the refrigerant in the liquid state.

⚠ CAUTION

- Never run the engine when charging the system through the **HI** pressure side.
- Do not open the **LO** pressure valve when refrigerant R134a is being charged in the liquid state (refrigerant container is set upside-down).

■ IMPORTANT

- After charging the refrigerant in the liquid state with approx. 500 g (1.1 lbs) through the **HI** pressure side, be sure to recharge the refrigerant in the vapor state to specified amount through the **LO** pressure side.

1. Close the **HI** and **LO** pressure side valves (5) and (6) of manifold gauge after the system is evacuated completely.
2. Connect the center charging hose (yellow) (7) to the can tap valve (1) fitting, and then loosen the center charging hose (yellow) (7) at the center fitting of manifold gauge until hiss can be heard.

Allow the air to escape for few seconds and tighten the nut.

3. Open the **HI** pressure side valve (5) fully, and keep the container upside-down to charge the refrigerant in the liquid state from the **HI** pressure side.
4. Charge the refrigerant in the liquid state with approx. 500 g (1.1 lbs) from the **HI** pressure side.

■ NOTE

- If **LO** pressure gauge does not show a reading, the system is clogged and must be repaired.
5. Close the **HI** pressure side valve (5) of manifold gauge and can tap valve of refrigerant container.

- (1) Can Tap Valve
- (2) Refrigerant Container (R134a)
- (3) Charging Hose (Red)
- (4) Charging Hose (Blue)
- (5) **HI** Pressure Side Valve
- (6) **LO** Pressure Side Valve
- (7) Charging Hose (Yellow)

- (A) Refrigerant Container "Upside"
- (B) Refrigerant Container "Down Side"

9Y1210982CAS0030US0

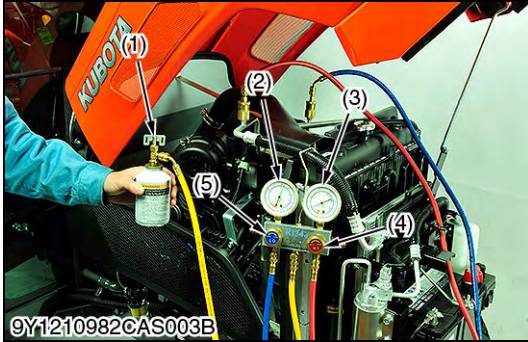

Charging an Empty or Partially Charged System (Vapor)

This procedure is to charge the system through the **LO** pressure side with refrigerant in the vapor state. When the refrigerant container is set right side up, refrigerant will enter the system as a vapor.

⚠ CAUTION

- Never open the **HI** pressure side valve of manifold gauge while the engine operates.

■ NOTE

- Do not turn the refrigerant container upside-down when charging the system by running the engine.
 - Put refrigerant container into a pan of warm water (maximum temperature 40 °C (104 °F)) to keep the vapor pressure in the container slightly higher than vapor pressure in the system.
1. Check that the **HI** pressure side valve (4) is closed.
 2. Start the engine and set an approx. 1500 min⁻¹ (rpm).
 3. Turn on the A/C switch.
Set the temperature control lever to **maximum cooling** position and the blower switch to **HI** position.
 4. Open the **LO** pressure side valve (5) of manifold gauge and the can tap valve (1) on refrigerant container and charge the refrigerant until air bubbles in the sight glass of the receiver vanish.
 5. After charging the specified amount of refrigerant into the system, close the **LO** pressure side valve (5) of manifold gauge and can tap valve (1), then stop the engine.
 6. Check for gas leak with an electric gas leak tester. (See page G-53.)

(Reference)

- Specified amount of refrigerant (total)
770 to 870 g (1.70 to 1.90 lbs) [Refrigerant R134a]
- Manifold gauge indication at fully charged system (at ambient temperature: 30 °C (86 °F))

HI pressure side

1.27 to 1.66 MPa (13 to 17 kgf/cm², 185 to 242 psi)

LO pressure side

0.15 to 0.20 MPa (1.5 to 2.0 kgf/cm², 21 to 28 psi)

- | | |
|------------------------------|-----------------------------------|
| (1) Can Tap Valve | (4) HI Pressure Side Valve |
| (2) LO Pressure Gauge | (5) LO Pressure Side Valve |
| (3) HI Pressure Gauge | |

9Y1210982CAS0031US0

(4) Checking Charging Refrigerant Amount

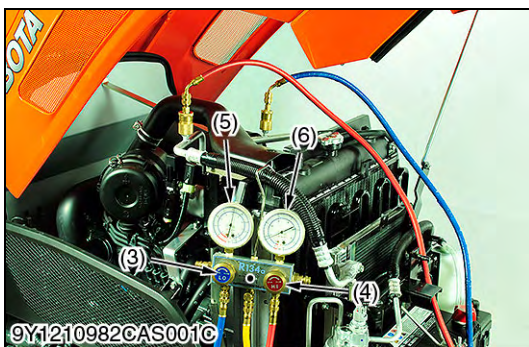
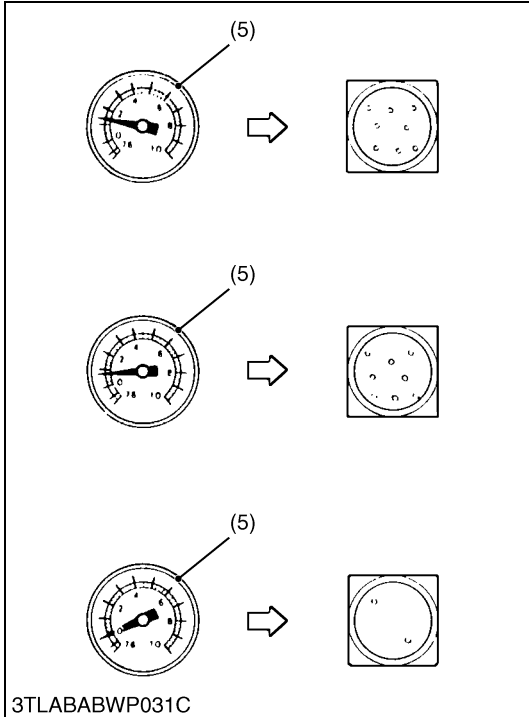
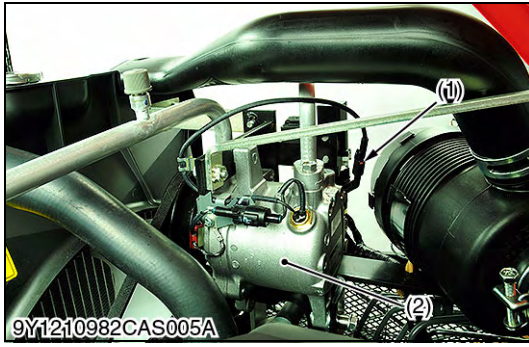

After charging the refrigerant, check for amount of charging refrigerant as follows.

■ **NOTE**

- **The pressure on the following checking are the gauge indications at ambient temperature 30 °C (86 °F), so it should be noted that the pressure will differ some what with the ambient temperature.**
1. Disconnect the **1P** connector (1) of magnetic clutch.
 2. Start the engine and set a approx. 1500 min⁻¹ (rpm).
 3. Connect the lead the **1P** connector (1) of magnetic clutch. Connect the lead to the battery positive terminal directly, and then set the blower switch to **HI** position.
 4. Leave the system for approx. 5 minutes until the refrigerant cycle becomes stable, keeping pressure on the **HI** pressure side from 1.27 to 1.66 MPa (13 to 17 kgf/cm², 185 to 242 psi).
 5. When the refrigerant cycle is stabilizer, turn off the blower switch and let the compressor alone to run. Then pressure on the **LO** pressure side gradually drops. At this time, if pressure on the **HI** pressure side is kept from 1.27 to 1.66 MPa (13 to 17 kgf/cm², 185 to 242 psi), air bubbles which pass through the sight glass becomes as stated below depending on refrigerant charged amount.

■ **Insufficient refrigerant charge**

Air bubbles pass continuously the sight glass when pressure on the **LO** pressure side is over 99.0 kPa (1.01 kgf/cm², 14.4 psi). In this case, charge the refrigerant from the **LO** pressure side.

■ **Properly refrigerant charge**

Air bubbles pass through the sight glass continuously when pressure on the **LO** pressure side is within 59 to 98 kPa (0.6 to 1.0 kgf/cm², 9 to 14 psi).

If the charge refrigerant amount is proper, no air bubble is observed on the sight glass at pressure on the **LO** pressure side over 99.0 kPa (1.01 kgf/cm², 14.4 psi) when the blower switch is turned on. When the blower switch is turned off, bubbles pass through the sight glass in case pressure on the **LO** pressure side is within 59 to 98 kPa (0.6 to 1.0 kgf/cm², 9 to 14 psi).

■ **Excessive refrigerant charge**

Air bubbles pass through the sight glass time to time or no air bubble is observed when pressure on the **LO** pressure side is under 59 kPa (0.6 kgf/cm², 9 psi).

In this case, discharge excessive refrigerant gradually from the **LO** pressure side.

- | | |
|--------------------------------------|------------------------------|
| (1) 1P Connector | (4) HI Pressure Valve |
| (2) Compressor | (5) LO Pressure Gauge |
| (3) LO Pressure Valve (Close) | (6) HI Pressure Gauge |

9Y1210982CAS0032US0

6. CHECKING, DISASSEMBLING AND SERVICING

[1] CHECKING AND ADJUSTING

(1) Compressor

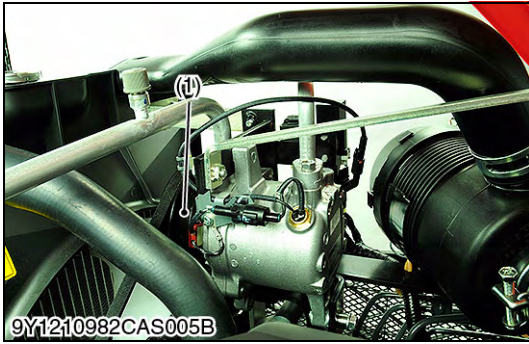

Operation of Magnetic Clutch

1. Turn off the A/C switch after starting the engine.
2. Check whether abrasion or abnormal noise is heard when only the magnetic clutch pulley operates.
3. Check that the magnetic clutch (1) does not slip when the A/C switch and blower switch are turned "ON" (when the air conditioner is in operation).
4. If anything abnormal is found, repair or replace.

(1) Magnetic Clutch

9Y1210982CAS0033US0

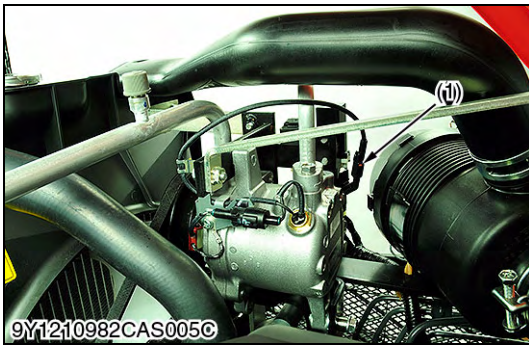

Stator Coil

1. Measure the resistance of the stator coil with an ohmmeter across the 1P connector (1) of magnetic clutch and compressor body.
2. If the measurement is not within the factory specifications, replace the stator coil.

Stator coil resistance	Factory specification	3.0 to 4.0 Ω
------------------------	-----------------------	--------------

(1) 1P Connector

9Y1210982CAS0034US0

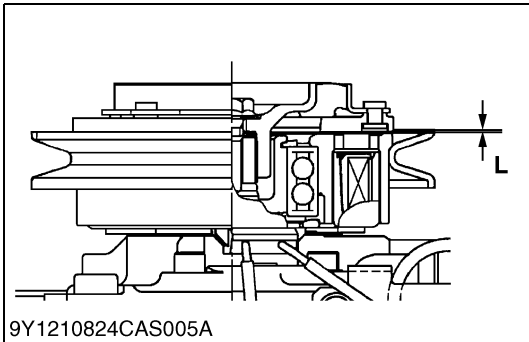

Air Gap

1. Check the air gap with feeler gauge.
2. If the measurement is not within the factory specifications, adjust it.

Air gap "L"	Factory specification	0.30 to 0.65 mm 0.012 to 0.025 in.
-------------	-----------------------	---------------------------------------

L: Air Gap

9Y1210982CAS0035US0

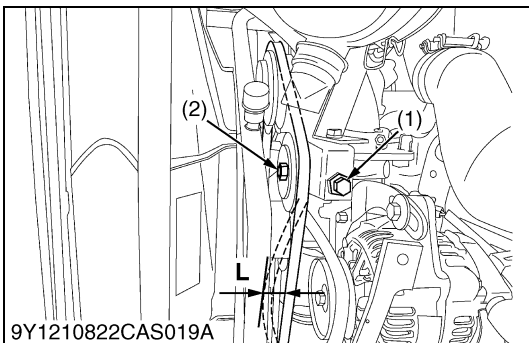

Adjusting Air Conditioner Belt Tension



- **Be sure to stop the engine before checking air conditioner belt tension.**

1. Stop the engine and remove the key.
2. Apply 98 N (10 kgf, 22 lbf) pressure to the belt between the pulleys.
3. If tension is incorrect, adjust the belt tension.
4. If belt is damaged, replace it.

Air conditioner belt tension	Factory specification	A deflection of between 10 to 12 mm (0.39 to 0.47 in.) when the belt is pressed in the middle of the span
------------------------------	-----------------------	---

(1) Adjusting Bolt
(2) Nut

L: Deflection

9Y1210982CAS0036US0

(2) Control Panel (Blower Switch, A/C Switch, Mode Control Dial and Temperature Control Dial)

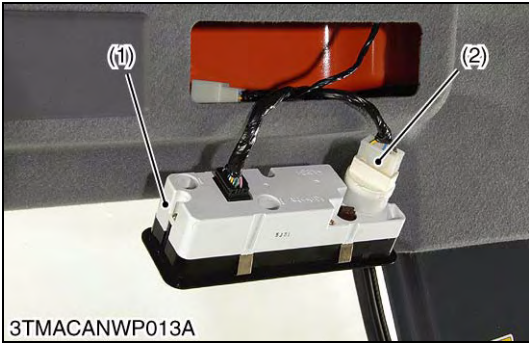

Blower Switch Connector Voltage

1. Disconnect the **6P** connector (2) from blower switch.
2. Turn the main switch to **"ON"** position.
3. Measure the voltage with a voltmeter across the connector terminal **a** and terminal **b**.
4. If the voltage differs from the battery voltage, the wiring harness, A/C relay, fuse or main switch is damaged.

Voltage	Terminal a – Terminal b	Approx. battery voltage
---------	-------------------------	-------------------------

- (1) Control Panel
(2) 6P Connector

(A) 6P Connector (Wire Harness Side)

9Y1210982CAS0037US0

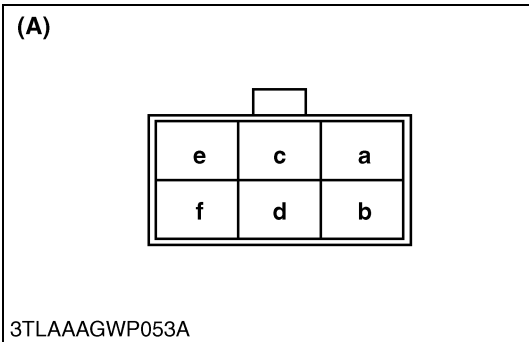
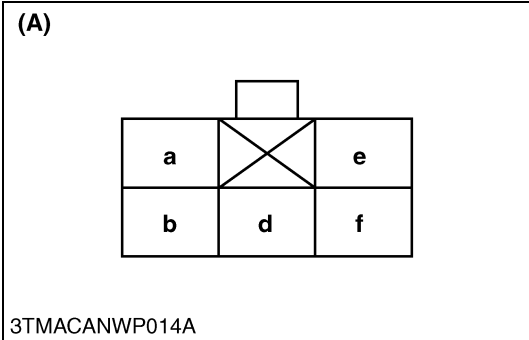

Blower Switch Test

1. Check the continuity through the switch with an ohmmeter.
2. If the continuity specified below are not indicated, the switch is damaged.

Position		Terminal					
		a	b	c	e	f	d
A/C blower switch	OFF						
	1 (Low)	●	●	●			
	2 (Medium)	●			●		
	3 (High)	●	●			●	

9Y1210982CAS021US

(A) 6P Connector (Blower Switch Side)

9Y1210982CAS0038US0

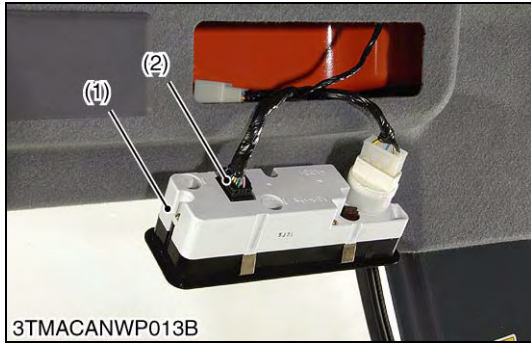

3TMACANWP013B

Connector Voltage

1. Disconnect the **16P** connector (2) from control panel switch.
2. Turn the main switch to **"ON"** position.
3. Measure the voltage with a voltmeter across the terminal **o** and terminal **a**.
4. If the voltage differs from the battery voltage, the wiring harness, A/C relay or fuse is damaged.

Voltage	Terminal o – Terminal a	Approx. battery voltage
---------	---------------------------------------	-------------------------

- (1) Control Panel (3) **16P** Connector (Wire Harness Side)
 (2) **16P** Connector (Switch Side)

9Y1210982CAS0039US0

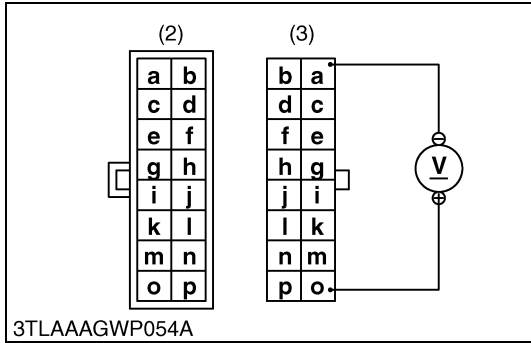

3TLAAAGWP054A

A/C Switch Checking

1. Measure the voltage with a voltmeter across the terminal **k** and chassis.
2. Turn the main switch to **"ON"** position.
3. Turn the blower switch to **"ON"** position.
4. Press the air conditioner switch to set it to **"OFF"** position (indicator: OFF), and then measure a voltage using a circuit tester.
5. Press the air conditioner switch to set it at **"ON"** position (indicator: ON), and then measure a voltage using a circuit tester.
6. If a measured voltage does not comply with the values in the table below, the control panel, wiring harness or fuse is damaged.

Voltage	Terminal k – Chassis	A/C switch at ON	Approx. battery voltage
		A/C switch at OFF	Approx. 1 V

- (1) **16P** Connector (Switch Side) (2) **16P** Connector (Wire Harness Side)

9Y1210982CAS0040US0

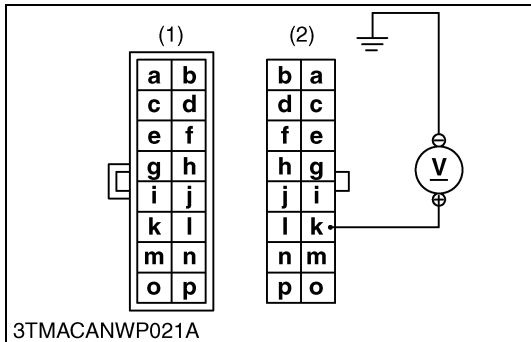

3TMACANWP021A

Mode Control Dial Checking

1. Disconnect the **16P** connector from control panel switch.
2. Check the continuity through the switch with an ohmmeter.
3. If the continuity specified below is not indicated, the switch is damaged.

Position		Terminal			
		l	n	p	m
Mode switch	FRONT	●			●
	FULL		●		●
	DEF			●	●

9Y1210982CAS022US

- (1) **16P** Connector (Switch Side)

9Y1210982CAS0041US0

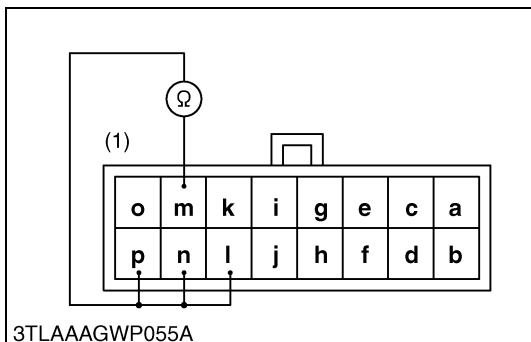

3TLAAAGWP055A

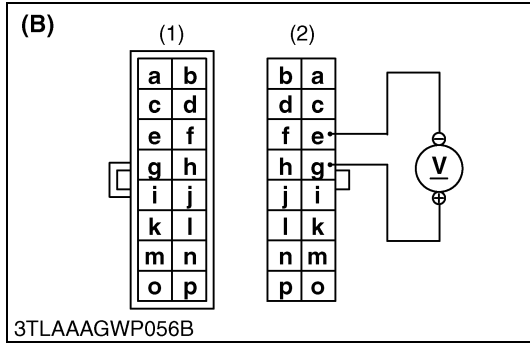
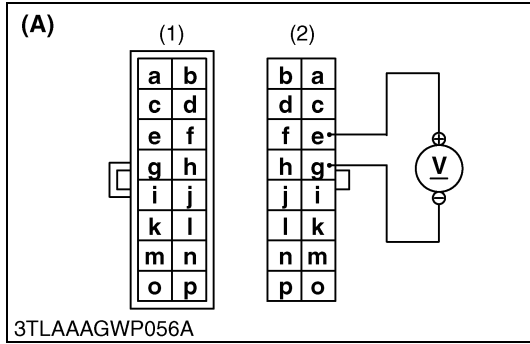

Temperature Control Dial Checking

1. Turn the temperature control dial counterclockwise till it stops (at "COOL" position).
2. Measure the voltage with a voltmeter across the terminal **b** and terminal **d**. Make the following measurement with the terminals connected.
3. Turn the main switch to "ON" position.
4. Check that an output voltage is approximately 10 V when turning the temperature control dial clockwise till it stops ("WARM" position).
5. Turn the main switch back to "OFF" position.
6. Turn the temperature control dial clockwise till it stops ("WARM" position).
7. Measure the voltage with a voltmeter across the terminal **d** and terminal **b**. Make the following measurement with the terminals connected.
8. Turn the main switch to "ON" position.
9. Check that an output voltage is approximately 10 V, when turning the temperature control dial counterclockwise till it stops ("COOL" position).
10. If an output voltage differs from approximately 10 V, the control panel, wiring harness or fuse is damaged.

- (1) 16P Connector (Switch Side)
- (2) 16P Connector (Wire Harness Side)
- (A) "COOL" position to "WARM" position
- (B) "WARM" position to "COOL" position

9Y1210982CAS0042US0

(3) Blower Resistor

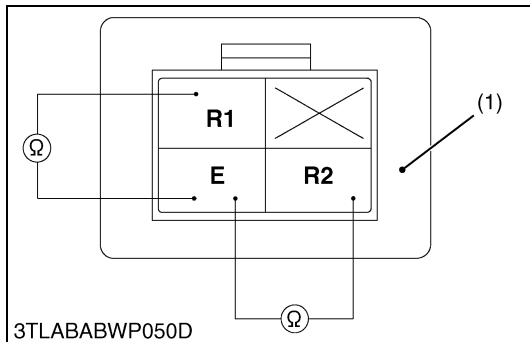

A/C Blower Resistor

1. Remove the inner roof.
2. Disconnect the 4P connector for A/C blower resistor (1).
3. Measure the resistance with an ohmmeter across the **R1** terminal and **E** terminal, and across the **R2** terminal and **E** terminal.
4. If the factory specifications are not indicated, A/C blower resistor is damaged.

Resistance	Factory specification	R1 terminal – E terminal	Approx. 0.56 Ω
		R2 terminal – E terminal	Approx. 1.56 Ω

- (1) A/C Blower Resistor

9Y1210982CAS0043US0

(4) Blower Motor

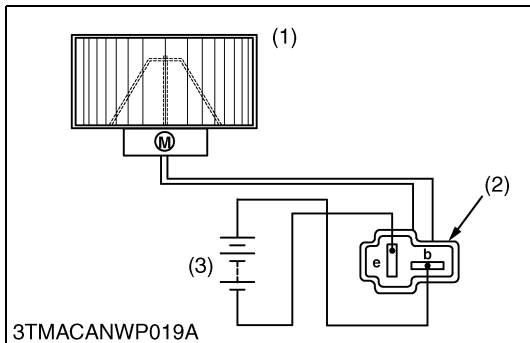

Blower Motor Test

1. Remove the outer roof.
2. Turn the blower motor (1) by hand and check whether it turns smoothly.
3. Disconnect the **2P** connector (2) of blower motor (1).
4. Connect a jumper lead from battery (3) positive terminal to connector terminal **b**.
5. Connect a jumper lead from battery negative terminal to connector terminal **e** momentarily.
6. If the blower motor does not run, check the motor.

- (1) Blower Motor
- (2) **2P** Connector (Blower Motor Side)
- (3) Battery (12 V)
- b:** Terminal **b**
- e:** Terminal **e**

9Y1210982CAS0044US0

(5) Temperature Motor

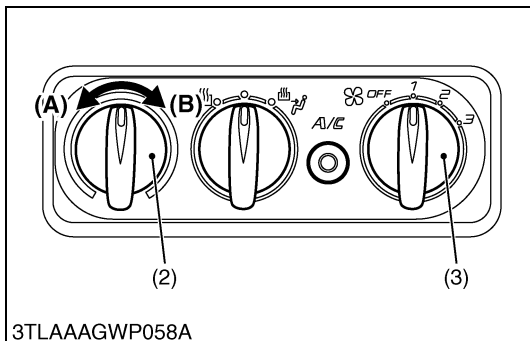
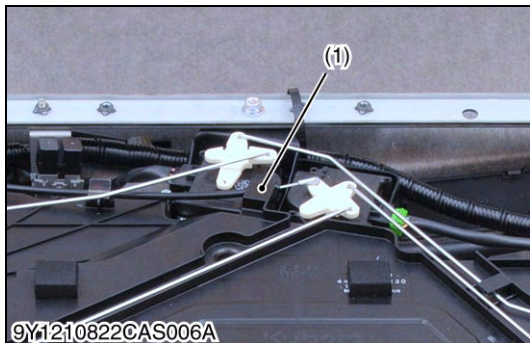

Temperature Motor Checking

1. Make sure whether the temperature control dial (2) is damaged. (See page 10-S23.)
2. Turn the main switch to "ON" position.
3. Turn the blower switch (3) at **1** position.
4. Turn the temperature control dial from "COOL" position (A) to "WARM" position (B). At the time, make sure the motor is operating.
5. If the motor does not operate, replace it.

- (1) Temperature Motor
- (2) Temperature Control Dial
- (3) Blower Switch
- (A)** COOL
- (B)** WARM

9Y1210982CAS0045US0

(6) Mode Motor

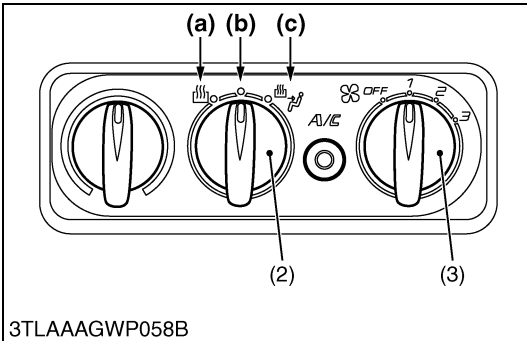
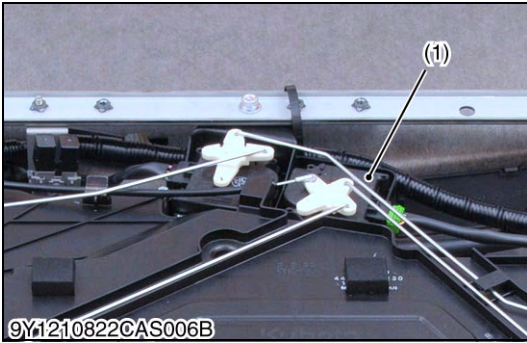

Mode Motor Checking

1. Make sure whether the mode switch (2) is damaged.
2. Turn the main switch to "ON" position.
3. Turn the blower switch at 1 position.
4. Turn the mode switch each (a), (b) and (c).
5. Make sure whether the position where the mode motor (1) is stopped synchronize with mode switch (2).
6. If the motor does not move, replace it.

- (1) Mode Motor
- (2) Mode Switch
- (3) Blower Switch

- (a) Air is blown from only the defroster air outlet
- (b) Air is blown weaker from the side air outlets (head) and stronger from the front air outlets
- (c) Air is blown from the front and side air outlets

9Y1210982CAS0046US0

(7) Air Conditioner Relay and Blower Relay

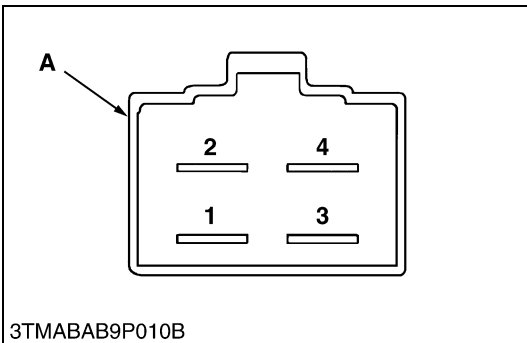
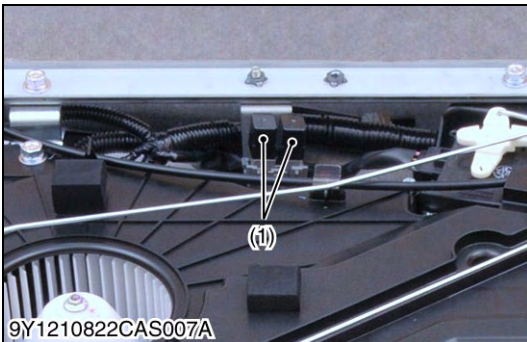

Checking Air Conditioner Relay and Blower Relay

1. Remove the air conditioner relay and blower relay.
2. Apply battery voltage across terminals 3 and 4, and check for continuity across terminals 1 and 2.
3. If continuity is not established, renew the relay.

- (1) Relay

A: Connector of Relay

9Y1210982CAS0047US0

(8) Pressure Switch

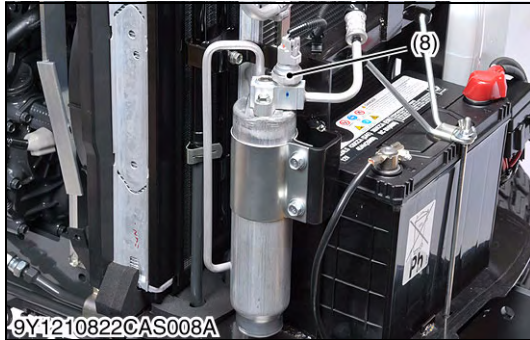
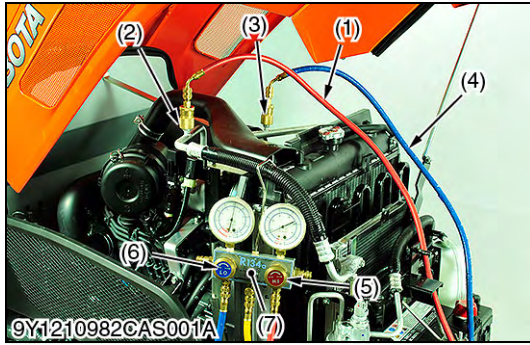

Pressure Switch

1) HI Pressure Side

1. Connect the manifold gauge (7) to compressor as following procedure.
Close the **HI** and **LO** pressure valves (2), (3) of manifold gauge tightly, and connect the charging hoses (1), (4) (red and blue) to the respective compressor service valves.

■ NOTE

- Be sure to drive out the air in the charging hoses at the manifold gauge connection end by utilizing the refrigerant pressure in the refrigerant cycle.
2. Start the engine and set at approx. 1500 min⁻¹ (rpm). Turn on the A/C switch, then set the blower switch to **HI** position.
 3. Raise pressure on the **HI** pressure side of the refrigerant cycle by covering the condenser front with a corrugated carboard, and the pressure switch is activated and the compressor magnetic clutch is turned off. At this time, read the **HI** pressure gauge of the manifold gauge. If this pressure reading differs largely with the setting pressure, replace the pressure switch with a new one.

Setting pressure	Factory specification	Pressure switch OFF	More than approx. 3.14 MPa (32 kgf/cm ² , 455 psi)
------------------	-----------------------	----------------------------	---

2) LO Pressure Side

1. Disconnect **2P** connector of pressure switch (8).
2. Measure the resistance with an ohmmeter across the connector terminals.
3. If 0 ohm is not indicated at normal condition, there is no refrigerant in the refrigerating cycle because gas leaks or pressure switch is damaged.

(Reference)

Setting pressure	Factory specification	Pressure switch OFF	Less than approx. 0.196 MPa (2.0 kgf/cm ² , 28.4 psi)
------------------	-----------------------	----------------------------	--

- The resistance of pressure switch is 0 ohm in normal condition, but it becomes infinity if the pressure is out of factory specification. Because the pressure switch starts to work.

- | | |
|--|-----------------------------------|
| (1) Charging Hose (Red) | (5) HI Pressure Side Valve |
| (2) HI Pressure Side Charging Valve | (6) LO Pressure Side Valve |
| (3) LO Pressure Side Charging Valve | (7) Manifold Gauge |
| (4) Charging Hose (Blue) | (8) Pressure Switch |

9Y1210982CAS0048US0

(10) Wiper Motor

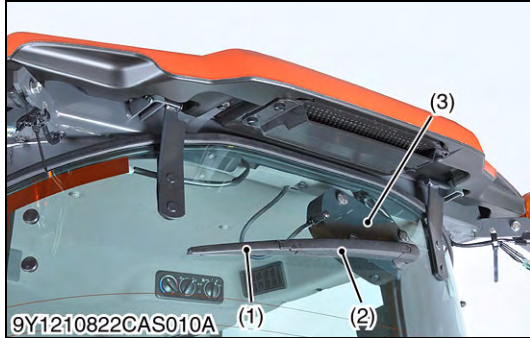
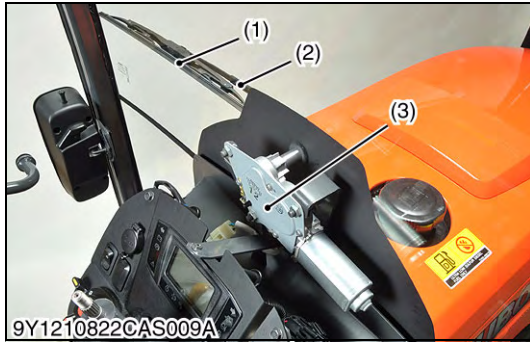

Front and Rear Wiper (Option) Motor

1. Raise up the wiper arm (2).
2. Turn the main switch to "ON" position.
3. Push the front wiper switch to "ON" position.
4. Count the number of wiper arm rocking per minutes.
5. If the number differs from the factory specifications, replace the wiper motor assembly.

No. of wiper arm swing frequency at no load	Factory specification	33 to 43 times/min.
---	-----------------------	---------------------

- (1) Wiper Blade
- (2) Wiper Arm

- (3) Wiper Motor

9Y1210982CAS0051US0

(11) Defogger

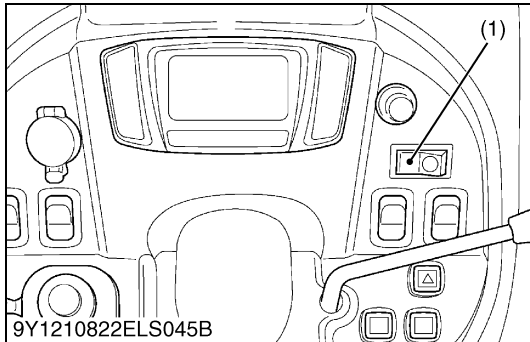

Defogger Switch

1. Remove the meter panel lower cover and disconnect the 3P connector from defogger switch (1).
2. Remove the defogger switch (1).
3. Perform the following checking.

- (1) Defogger Switch

9Y1210982CAS0052US0

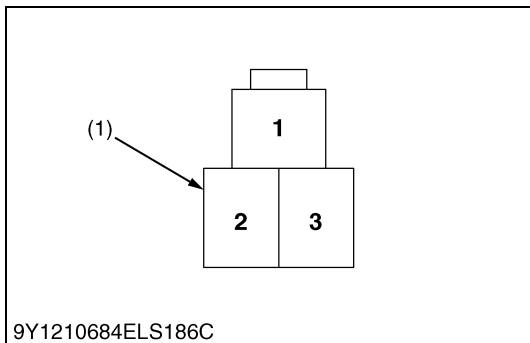

1) Connector Voltage

1. Turn the main key switch "ON" position.
2. Measure the voltage with a voltmeter across the terminals shown in the table below.
3. If the reference value as shown in the table below is not indicated, check the relating electric circuit.

Voltage	Main switch at "ON"	Terminal 1 – Chassis	Approx. battery voltage
---------	---------------------	----------------------	-------------------------

- (1) Connector (Harness Side)

9Y1210982CAS0053US0

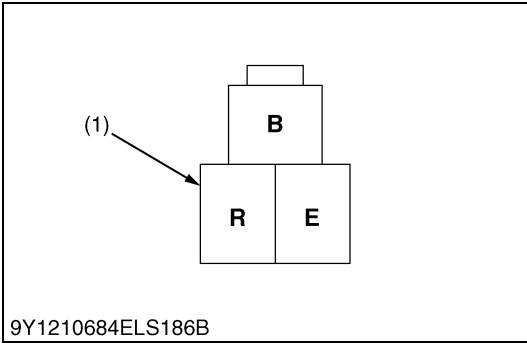

2) Switch Continuity

1. Check the continuity across the terminals shown in the table below.
2. If the continuity specified below is not indicated, the switch is damaged.

Position		Terminal		
		B	R	E
Defogger switch	OFF		●—●	●—●
	ON	●—●	●—●	●—●

9Y1210982CAS024US

(1) Connector (Switch Side)

9Y1210982CAS0054US0

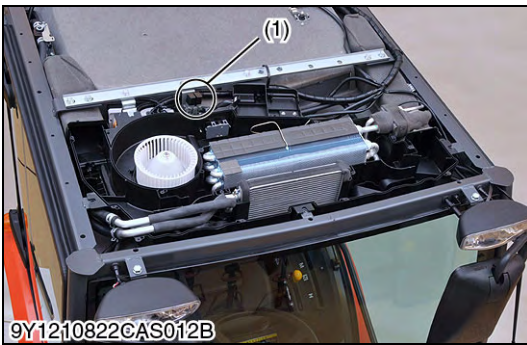

Other Relays

1. Remove the relays (1).
2. Apply battery voltage across 1 terminal and 2 terminal, and check for continuity across the 3 terminal and 4 terminal.
3. If 0 Ω is not indicated, renew the relays (1).

Resistance	3 terminal – 4 terminal	Battery voltage is applied across 1 terminal and 2 terminal	0 Ω
------------	-------------------------	---	-----

Color of wiring

Item	Terminal No.	Color of Wiring
Defogger Relay	1	Gr/R
	2	B
	3	W/R
	4	P
Blower Relay	1	Lg
	2	G/Y
	3	W/B
	4	P/L
Compressor Relay	1	Lg
	2	Y/G
	3	G
	4	Lg

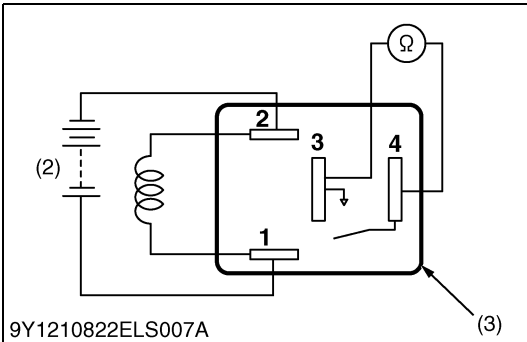

- (1) Relay
- (2) Battery

- (3) Connector (Relay)
- (4) Connector (Wire Harness)

9Y1210982CAS0055US0

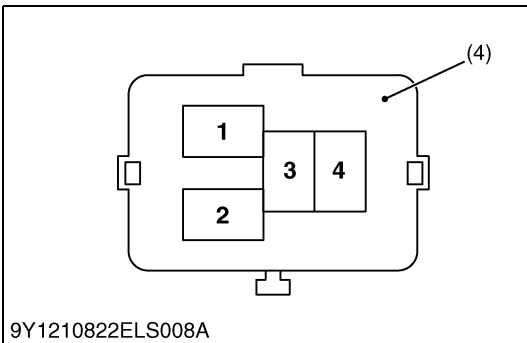

[2] DISASSEMBLING AND ASSEMBLING

(1) Separating Cabin from Tractor Body

■ **NOTE**

- Without discharging the refrigerant from system.

9Y1210982CAS0056US0



Battery Cable

1. Open the bonnet and remove the side cover and bonnet.
2. Disconnect the battery negative cable (1).

■ **NOTE**

- **When disconnecting the battery cables, disconnect the grounding cable first. When connecting, the positive cable first.**

- (1) Battery Negative Cable

9Y1210982CAS0057US0



Rear Wheel and 3-Point Linkage

1. Place the disassembling stand under the transmission case.
2. Remove the rear wheel (1).
3. Remove the top link, lower links and lift rods.

Tightening torque	Rear wheel mounting nut	B3150	167 to 191 N·m 17 to 19.5 kgf·m 123 to 141 lbf·ft
	Rear wheel mounting screw		196 to 225 N·m 20 to 23 kgf·m 145 to 166 lbf·ft
	Rear wheel mounting nut and screw	B2650 B2350 B2050	108 to 126 N·m 11.1 to 12.8 kgf·m 79.7 to 92.9 lbf·ft

- (1) Rear Wheel

9Y1210982CAS0058US0

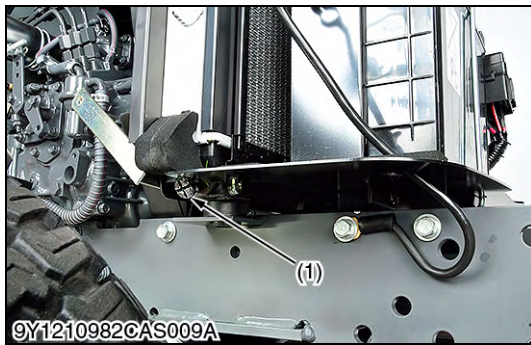

Draining Coolant

⚠ **CAUTION**

- **Never remove the radiator cap until coolant temperature is well below its boiling point. Then loosen cap slightly to the stop to relieve any excess pressure before removing cap completely.**

1. Stop the engine and let cool down.
2. To drain the coolant, turn the drain plug (1) counterclockwise.
3. Remove the radiator cap to completely drain the coolant.
4. After all coolant is drained, reinstall the radiator drain plug.

(When reassembling)

Coolant	Capacity	4.3 L 4.5 U.S.qts 3.8 Imp.qts
---------	----------	-------------------------------------

- (1) Drain Plug

9Y1210982CAS0076US0

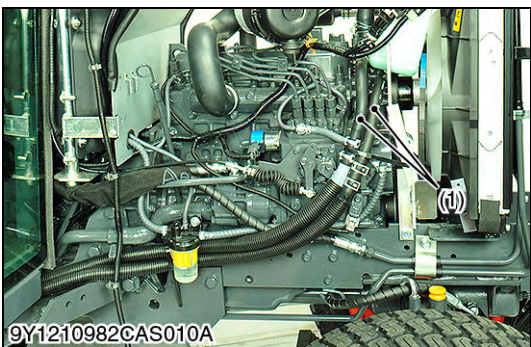

Heater Hose

1. Disconnect the heater hoses (1), and then reconnect their hoses to make loop.

■ **NOTE**

- Put a mark to the each heater hoses before disconnecting.

- (1) Heater Hose

9Y1210982TRS0009US0

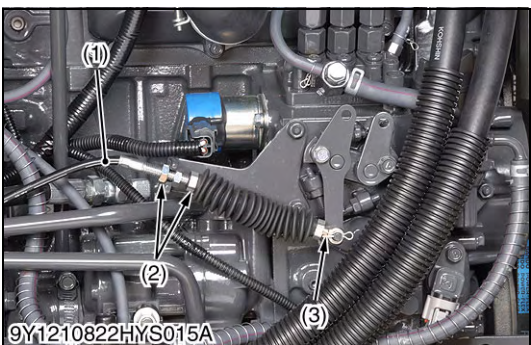

Accelerator Wire

1. Disconnect the accelerator wire (1).

(When reassembling)

- Set the end of wire inner (3) first. Then adjust the length of the wire outer section so that the wire inner section has no play, and tighten the lock nut (2).

- (1) Accelerator Wire
- (2) Lock Nut
- (3) Accelerator Inner

9Y1210982TRS0010US0



Seat and Lever Guide

1. Disconnect the OPC switch connector and remove the seat (1).
2. Remove the each lever grips (2).
3. Remove the lever guides (3).

- (1) Seat
- (2) Lever Grip
- (3) Lever Guide

9Y1210982TRS0011US0



Seat Under Cover

1. Remove the seat under cover (1).

- (1) Seat Under Cover

9Y1210982TRS0012US0

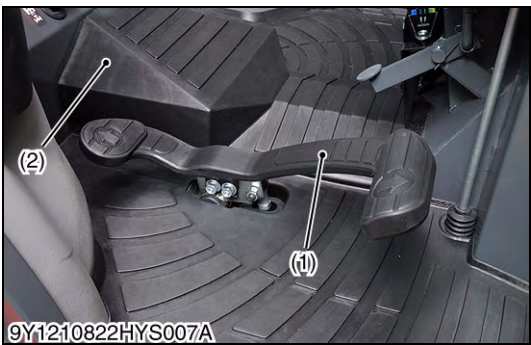

HST Pedal and Floor Mat

1. Remove the HST pedal (1) and floor mat (2).

- (1) HST Pedal
- (2) Floor Mat

9Y1210982TRS0013US0

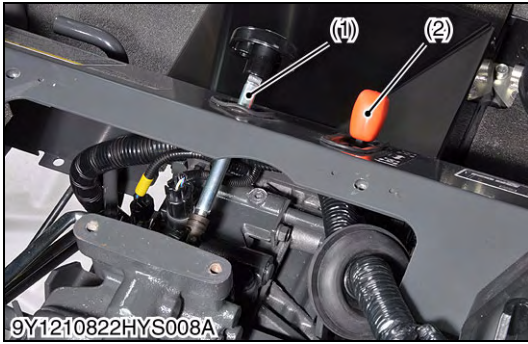

Lowering Speed Adjusting Shaft and Front Wheel Drive Lever Knob

1. Tap out the spring pin and remove the lowering speed adjusting shaft (1).
2. Remove the front wheel drive lever knob (2).

(1) Lowering Speed Adjusting Shaft (2) Front Wheel Drive Lever Knob

9Y1210982TRS0014US0

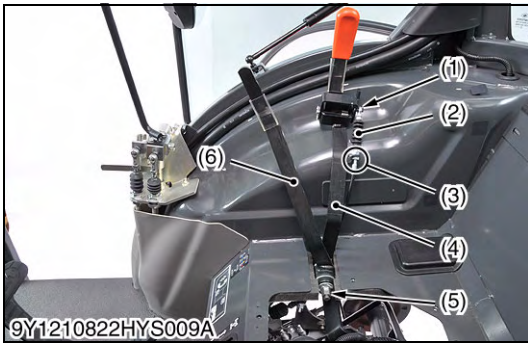

Position Control Lever and Cruise Control Lever

1. Remove the cruise control cable (2) from cruise control lever (4).
2. Remove the lever mounting nut (5), cruise control lever (4) and position control lever (6).

(When reassembling)

- Set the end of cable inner first. Then adjust the length of the cruise control cable outer section so that the cable inner section (1) has no play, and tighten the lock nut (3). (Due to a force of the spring in cruise control lever (4), the lever is set to the right side (outside) from the operator's seat.)

(1) Cable Inner Section (4) Cruise Control Lever
 (2) Cruise Control Cable (5) Lever Mounting Nut
 (3) Lock Nut (6) Position Control Lever

9Y1210982TRS0015US0

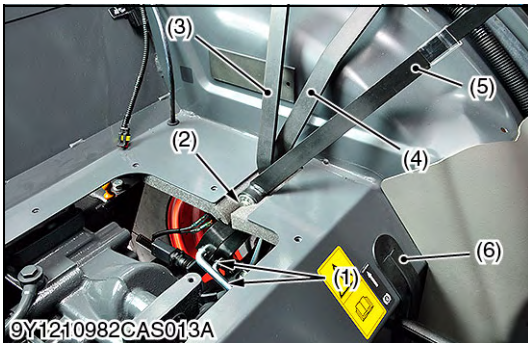

Range Gear Shift Lever, PTO Clutch Lever, PTO Select Lever and Rubber Cover

1. Remove the spring lock pins from shift rods (1).
2. Remove the external circlip (2), range gear shift lever (3), PTO clutch lever (5), and PTO select lever (4).
3. Remove the rubber cover for parking brake lever (6).

(1) Shift Rod (4) PTO Select Lever
 (2) External Circlip (5) PTO Clutch Lever
 (3) Range Gear Shift Lever (6) Rubber Cover

9Y1210982TRS0016US0

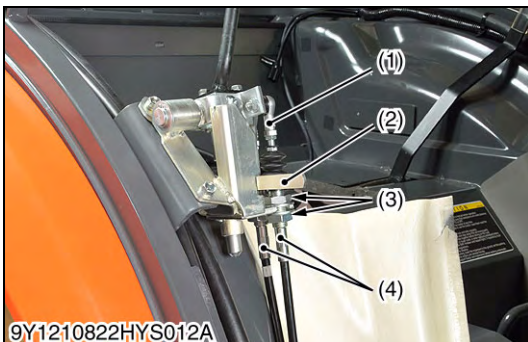

Front Loader Cables

1. Loosen the lock nuts (3) and remove the front loader cables (4).

(When reassembling)

- Set the lock lever (2) to lock position.
- Fix the ball joint (1) first.
- Adjust the length of the front loader cable (4) outer section so that the cable inner section has no play, and tighten the lock nut (3).

(1) Ball Joint (3) Lock Nut
 (2) Lock Lever (4) Front Loader Cable

9Y1210982TRS0017US0

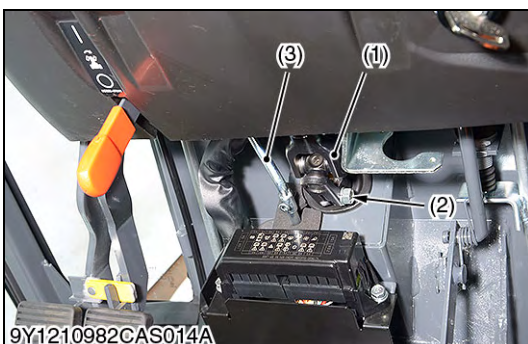

Universal Joint Mounting Bolt and Bi-speed Rod

1. Remove the universal joint mounting bolt (2).
2. Disconnect the Bi-speed rod (3).

(When reassembling)

Tightening torque	Universal joint mounting bolt	24 to 28 N·m 2.5 to 2.8 kgf·m 18 to 20 lbf·ft
-------------------	-------------------------------	---

(1) Universal Joint (3) Bi-speed Rod
 (2) Bolt

9Y1210982TRS0018US0

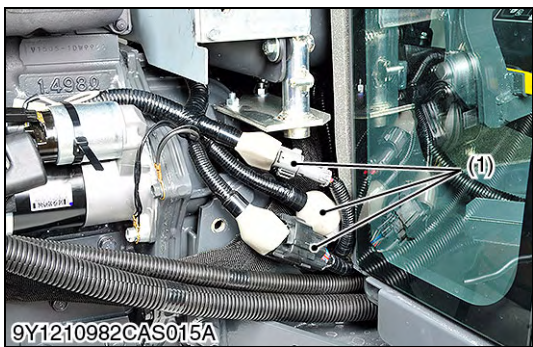

Electric Wiring

1. Disconnect the wiring connectors (1).

- (1) Wiring Connector

9Y1210982TRS0019US0

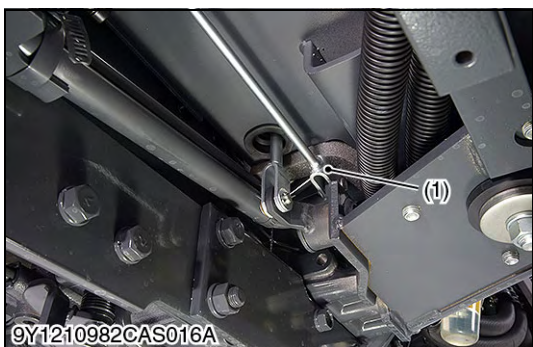

Brake Pedal Rods

1. Disconnect the both left and right sides brake pedal rods (1).

- (1) Brake Pedal Rod

9Y1210982TRS0020US0



Cabin Mounting Bolts

1. Remove the bolts and nuts (1).

(When reassembling)

Tightening torque	Cabin mounting bolt and nut	124 to 150 N·m 12.7 to 15.2 kgf·m 91.5 to 110 lbf·ft
-------------------	-----------------------------	--

- (1) Bolt and Nut

9Y1210982TRS0021US0



Cabin Assembly

1. Hook the cabin with nylon slings not to damage the cabin.
2. Dismount the cabin from the tractor body.
3. Support the cabin with a stand.

■ **NOTE**

- Lift and turn the cabin while making sure it does not catch on anything.

(When reassembling)

- Be sure to install the washer and mount rubbers, etc, in their original position.

9Y1210982TRS0022US0

(2) Removing Compressor Assembly

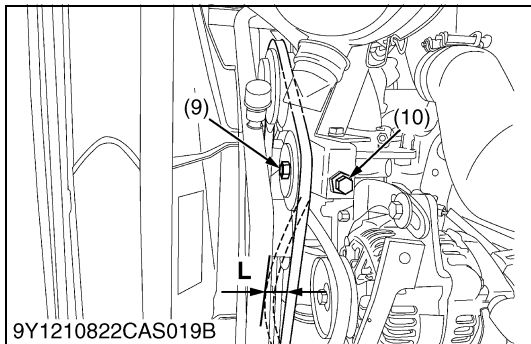
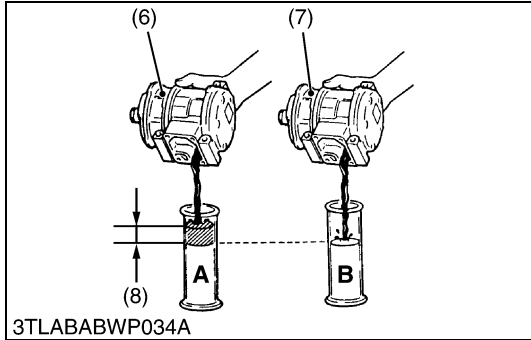
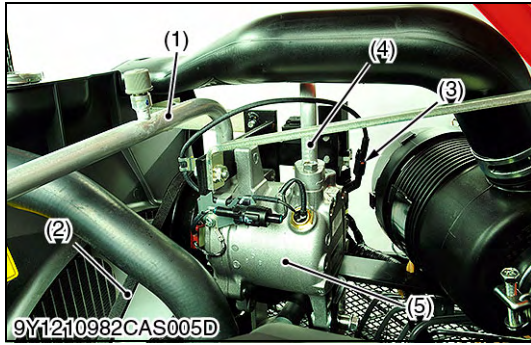

Compressor Assembly

1. Discharge the refrigerant from the system. (See page 10-S17.)
2. Disconnect the low pressure pipe (suction) (4) and high pressure pipe (discharge) (1) from the compressor, then cap the open fitting immediately to keep moisture out of the system.
3. Disconnect the **1P** connector (3) of magnetic clutch.
4. Remove the air conditioner belt (2) and remove the compressor (4) with stay.

(When reassembling)

- After reassembling the compressor, be sure to adjust the air conditioner belt tension and recharge the refrigerant to the system. (See page 10-S17.)
- Apply compressor oil (DENSO CO. ND-OIL8 or equivalent) to the O-rings and be careful not to damage them.
- **"S"** letter is marked on the compressor for connecting the low pressure pipe (suction side).
- **"D"** letter is marked on the compressor for connecting the high pressure pipe (discharge side).
- When replacing the compressor with a new one, meet the oil amount with old one.
- Push on the belt between the pulleys with a finger. Deflection **"L"** of 10 to 12 mm (0.40 to 0.48 in.) under a 98 N (10 kgf, 22 lbf) load is appropriate.

Tightening torque	High pressure pipe and low pressure pipe mounting screw	7.90 to 11.8 N·m 0.806 to 1.20 kgf·m 5.83 to 8.70 lbf·ft
	Compressor mounting screws	24.5 to 29.4 N·m 2.50 to 2.99 kgf·m 18.1 to 21.6 lbf·ft

- (1) High Pressure Pipe
- (2) Air Conditioner Belt
- (3) **1P** Connector (Magnetic Clutch)
- (4) Low Pressure Pipe
- (5) Compressor
- (6) New Compressor
- (7) Old Compressor
- (8) Remove the Excess Oil (**A-B**)
- (9) Tension Pulley Bolt
- (10) Adjusting Bolt

- A:** Oil Flow New Compressor
- B:** Oil Flow Replace Compressor
- L:** Deflection
(10 to 12 mm (0.40 to 0.48 in.))

9Y1210982CAS0059US0

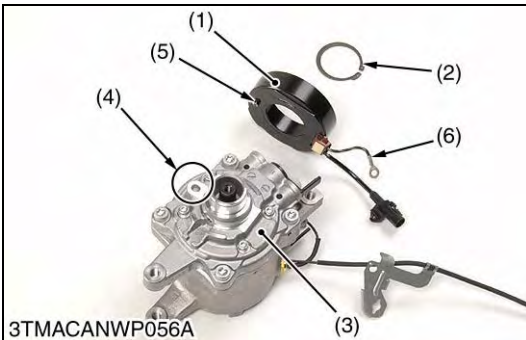
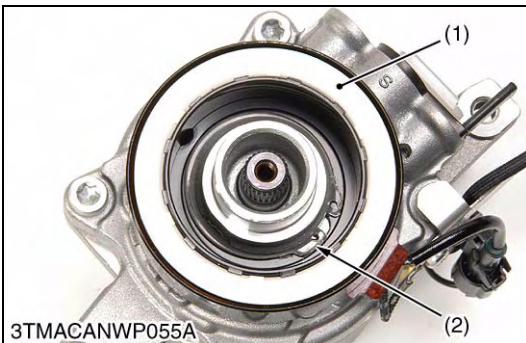
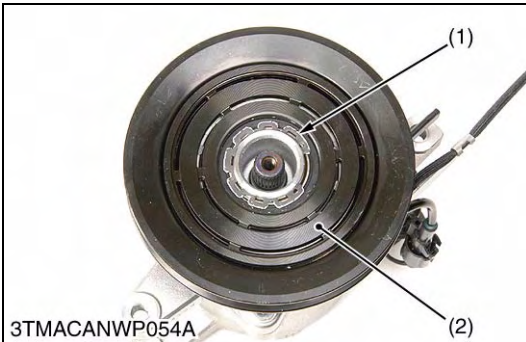
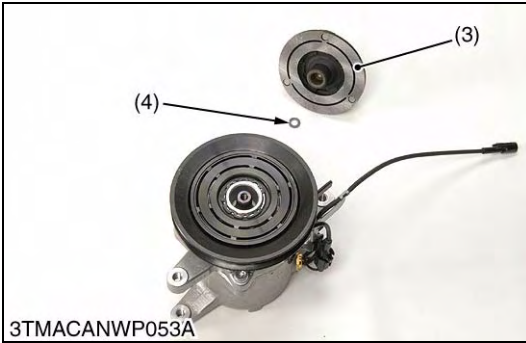
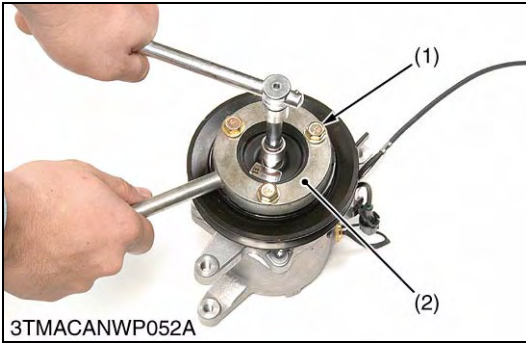

Hub Plate

1. Three stopper bolts (1) are set in stopper magnetic clutch (2) at the position corresponding to the shape of compressor.
2. The stopper magnetic clutch (2) is hung on hub plate (3) and it is fixed that the compressor rotates.
3. Remove the magnetic clutch mounting screw.
4. Remove the hub plate (3) and air gap adjustment shim (4).

(When reassembling)

- Do not apply grease or oil on the hub plate facing.
- Do not use the magnetic clutch mounting screw again.
- Make sure to turn rotor by hand after assembling and not contact with stator and hub plate.
- Check and adjust the air gap before tight the magnet clutch mounting screw to the specified torque.

Tightening torque	Magnetic clutch mounting screw	15 to 21 N·m 1.5 to 2.1 kgf·m 11 to 15 lbf·ft
-------------------	--------------------------------	---

- (1) Stopper Bolt (3) Hub Plate
(2) Stopper Magnetic Clutch (4) Shim

9Y1210982CAS0060US0

Rotor

1. Remove the external circlip (1).
2. Remove the rotor (2).

(When reassembling)

- Do not use the external circlip again.
- Assemble the external circlip for the tapered side to become outside of rotor.
- The width of expanding of external circlip is set in boss of shaft as a minimum.

(Reference)

- Code No. for external circlip: T1065-87450

- (1) External Circlip (2) Rotor

9Y1210982CAS0061US0

Stator

1. Remove the lead wire (6) from compressor body.
2. Remove the external circlip (2).
3. Remove the stator (1).

(When reassembling)

- Do not use the external circlip again.
- Assemble the external circlip for the tapered side to become outside of front housing.
- The width of expanding of external circlip is set is boss of shaft as a minimum.
- Match and assemble the concave part (4) of the front housing (3) and the pin (5) of stator.

(Reference)

- Code No. for external circlip: T1065-87440

- (1) Stator (4) Concave Part
(2) External Circlip (5) Pin
(3) Front Housing (6) Lead Wire

9Y1210982CAS0062US0

(3) Removing Receiver and Condenser

Discharging Refrigerant

- See page 10-S17.

9Y1210982CAS0079US0

Removing Receiver and Condenser

1. Disconnect the pressure switch (6) and high pressure hose 1 (3) and high pressure hose 2 (7).
2. Remove the bolts (2) from the receiver (1).
3. Remove the bolts (4).
4. Remove the receiver (1) with condenser (5) from the tractor body.

(When reassembling)

- Do not damage the O-rings.

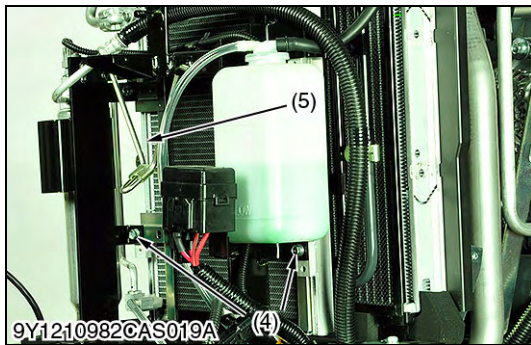

Tightening torque	High pressure hose 1 mounting screw (condenser side)	4.0 to 6.8 N·m 0.41 to 0.69 kgf·m 3.0 to 5.0 lbf·ft
	High pressure hose 2 retaining nut (receiver side)	4.0 to 6.8 N·m 0.41 to 0.69 kgf·m 3.0 to 5.0 lbf·ft

- | | |
|--------------------------|--------------------------|
| (1) Receiver | (5) Condenser |
| (2) Bolt | (6) Pressure Switch |
| (3) High Pressure Hose 1 | (7) High Pressure Hose 2 |
| (4) Bolt | |

9Y1210982CAS0064US0

(4) Removing Air Conditioner Unit

Draining Coolant

- See page 1-S23.

9Y1210982CAS0078US0

Discharging Refrigerant

- See page 10-S17.

9Y1210982CAS0079US0

Outer Roof and Stay

1. Remove the outer roof (1).
2. Remove the stay (2).

Tightening torque	Outer roof mounting bolt	3.5 to 4.0 N·m 0.36 to 0.40 kgf·m 2.6 to 2.9 lbf·ft
-------------------	--------------------------	---

- | | |
|----------------|----------|
| (1) Outer Roof | (2) Stay |
|----------------|----------|

9Y1210982CAS0080US0

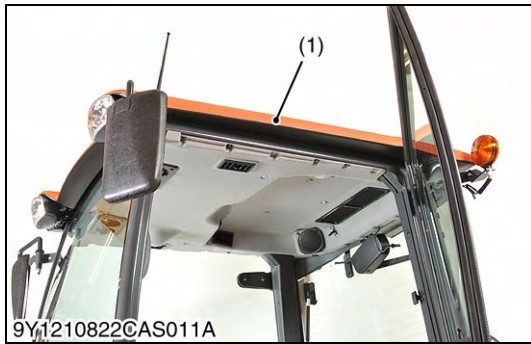



Wiring Harness

1. Remove the inner roof.
2. Disconnect the temperature motor connector (3), and thermostat connectors (4).
3. Disconnect the mode motor connector (2) and blower resistor (1) connector.

- | | |
|--------------------------|---------------------------------|
| (1) Blower Resister | (3) Temperature Motor Connector |
| (2) Mode Motor Connector | (4) Thermostat Connector |

9Y1210982CAS0081US0

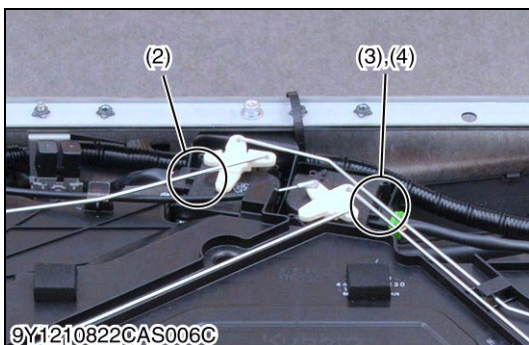

Water Cable, Temperature Motor and Mode Motor

1. Disconnect the water cable (1).
2. Remove the motor screws (2).

- | | |
|-----------------|--------------------------|
| (1) Water Cable | L: 6 mm (0.2 in.) |
| (2) Motor Screw | |

9Y1210982CAS0082US0



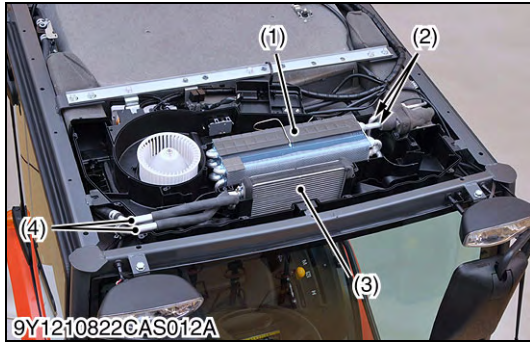

Air Conditioning Unit

1. Remove the unit cover.
2. Disconnect the heater hoses (4).
3. Disconnect the air conditioner pipes (2).
4. Remove the screws and the unit.
5. Remove the duct hoses.

(When reassembling)

- When reconnecting the cooler pipes with the unit, apply compressor oil (DENSO CO. ND-OIL8 or equivalent) to O-rings.
- When remounting the unit, tighten five screws by hand and finally retighten them after aligning the inner roof duct with the unit duct.
- When connecting the heater hose with A/C unit, hose should be put into the A/C unit pipe more than 30 mm (1.2 in.)

Tightening torque	A/C unit mounting screw (M6)	4.0 to 6.8 N·m 0.40 to 0.70 kgf·m 2.9 to 5.0 lbf·ft
	A/C unit mounting screw (M8)	9.81 to 11.6 N·m 1.00 to 1.19 kgf·m 7.24 to 8.60 lbf·ft
	Low pressure pipe (Cooler pipe (suction)) retaining nut	7.90 to 11.8 N·m 0.806 to 1.20 kgf·m 5.83 to 8.70 lbf·ft
	High pressure pipe (Cooler pipe (liquid)) retaining nut	11.8 to 14.7 N·m 1.21 to 1.49 kgf·m 8.71 to 10.8 lbf·ft

- | | |
|--------------------------|------------------|
| (1) Evaporator | (3) Heater Core |
| (2) Air Conditioner Pipe | (4) Heater Hoses |

9Y1210982CAS0083US0

(5) Removing Air Conditioner Pipes

Discharging Refrigerant

- See page 10-S17.

9Y1210982CAS0079US0

Bonnet

- See page 1-S24.

9Y1210982CAS0084US0

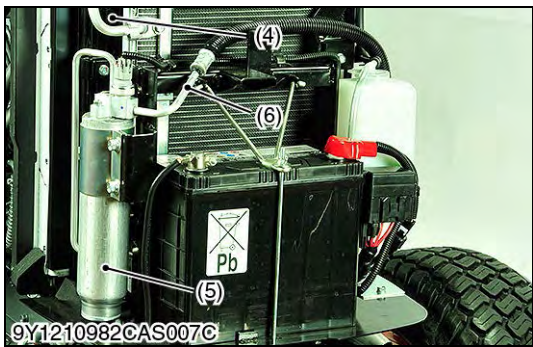
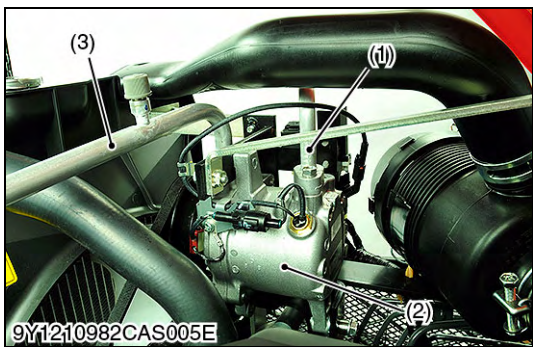

High Pressure Hose 1, 2 and Low Pressure Hose

1. Disconnect the low pressure hose (3) and high pressure hose 1 (1) from the compressor (2), then cap the open fittings immediately to keep moisture out of the system.
2. Slide the condenser (4).
3. Disconnect the high pressure hose 1 (1) from the condenser (4) and cap the place immediately which disconnected pressure hose to keep moisture out of the system.
4. Disconnect the high pressure hose 2 (6) from the receiver (5) and cap the place immediately which disconnected pressure hose to keep moisture out of the system.

(When reassembling)

- Apply compressor oil (DENSO CO. ND-OIL8) to the O-rings and be careful not to damage them.

Tightening torque	Low pressure hose mounting screw (compressor side)	7.9 to 11.8 N·m 0.81 to 1.20 kgf·m 5.9 to 8.70 lbf·ft
	High pressure hose 1 mounting screw (compressor side)	7.9 to 11.8 N·m 0.81 to 1.20 kgf·m 5.9 to 8.70 lbf·ft
	High pressure hose 1 mounting screw (condenser side)	4.0 to 6.8 N·m 0.41 to 0.69 kgf·m 3.0 to 5.0 lbf·ft
	High pressure hose 2 retaining nut (receiver side)	4.0 to 6.8 N·m 0.41 to 0.69 kgf·m 3.0 to 5.0 lbf·ft

- | | |
|--------------------------|--------------------------|
| (1) High Pressure Hose 1 | (4) Condenser |
| (2) Compressor | (5) Receiver |
| (3) Low Pressure Hose | (6) High Pressure Hose 2 |

9Y1210982CAS0085US0

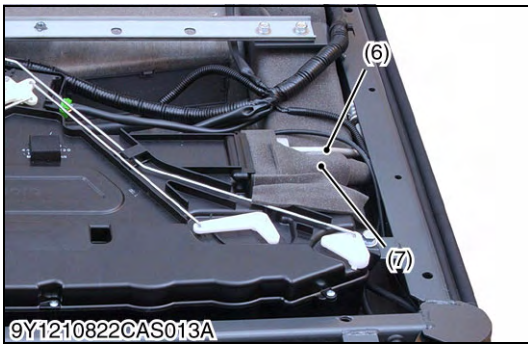
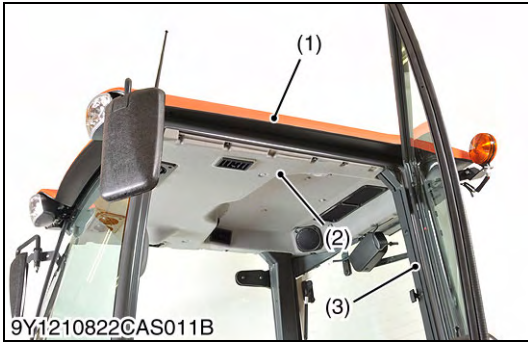

(6) Removing Heater Hoses

High Pressure and Low Pressure Pipes

1. Remove the outer roof (1), inner roof (2) and inner cover (3).
2. Remove the lever grips and lever guide (4).
3. Remove the floor mat (5).
4. Disconnect the high pressure pipe 2 (7), then cap the open fitting immediately to keep moisture out of the system.
5. Remove the rubber and disconnect the low pressure pipe (6), then cap the open fittings immediately to keep moisture out of the system.

(When reassembling)

- Replace the rubber with a new one.
- Apply compressor oil (DENSO ND-OIL 8 or equivalent) to the O-rings and be careful not to damage them.

Tightening torque	High pressure pipe 2 retaining nut	7.90 to 11.8 N·m 0.806 to 1.20 kgf·m 5.83 to 8.70 lbf·ft
	Low pressure pipe retaining nut	7.90 to 11.8 N·m 0.806 to 1.20 kgf·m 5.83 to 8.70 lbf·ft

- | | |
|-----------------|--------------------------|
| (1) Outer Roof | (5) Floor Mat |
| (2) Inner Roof | (6) Low Pressure Pipe |
| (3) Inner Cover | (7) High Pressure Pipe 2 |
| (4) Lower Guide | |

9Y1210982CAS0086US0

Battery Cable

- See page G-22.

9Y1210982CAS0087US0

Draining Coolant

- See page 1-S23.

9Y1210982CAS0078US0

Bonnet

- See page 1-S24.

9Y1210982CAS0084US0

Hose Clamp

1. Disconnect the heater hoses (1), then remove them under the cabin.

NOTE

- Before disconnecting the heater hoses (1), put the parting marks on the hoses for marking proper reconnecting.

(When reassembling)

- Connecting the heater hoses at their original position.

- (1) Heater Hoses

9Y1210982CAS0088US0

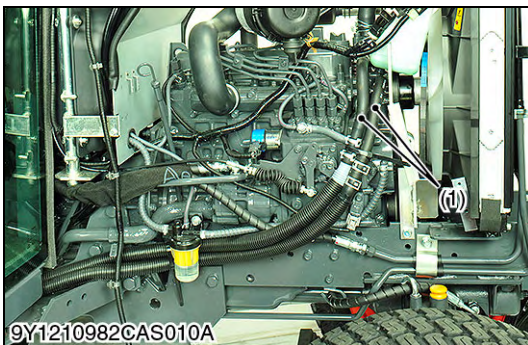

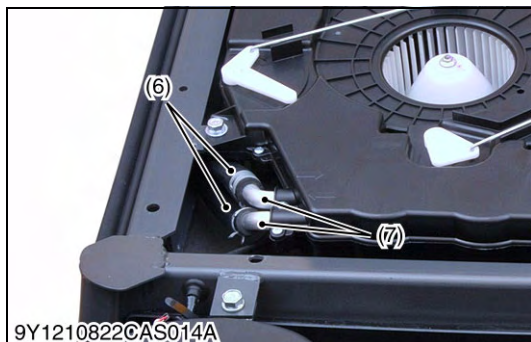
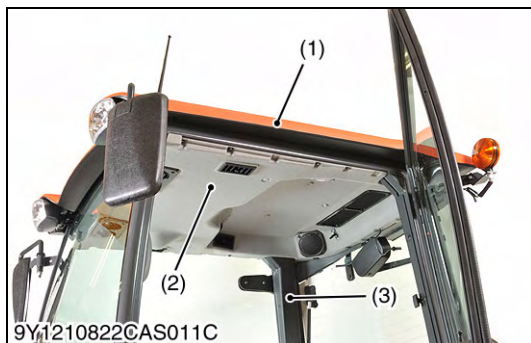

Heater Hoses

1. Remove the outer roof (1), inner roof (2) and inner cover (3).
2. Remove the lever grips, lever guide (4) and floor mat (5).
3. Disconnect the heater hoses (6) from the hose pipes (7).
4. Pull out the heater hoses (6) from the bottom of the cabin.
5. Remove the heater hoses (6).

NOTE

- Before disconnecting the heater hoses (6), put the parting marks on the hoses for marking proper reconnecting.

(When reassembling)

- Connect the heater hoses at their original positions.
- In assembling the heater hose (6) to the pipe (7), connect the heater hose with identification mark (white paint) to upper side of the hose pipe.
- When connecting the heater hose with A/C unit, hose should be put into the A/C unit pipe more than 30 mm (1.2 in.).

- | | |
|-----------------|-----------------|
| (1) Outer Roof | (5) Floor Mat |
| (2) Inner Roof | (6) Heater Hose |
| (3) Inner Cover | (7) Heater Pipe |
| (4) Lever Guide | |

9Y1210982CAS0089US0

(7) Cabin Windshields

Preparation

1. Prepare the followings.
 - Cutter knife :1 piece
 - Scraper : 1 piece
 - Gun for coating : 1 piece
 - Sika Flex 250P-JM-1 or equivalent
 - Gummed tape
 - Sika primer 260P-JM-1
 - Shin Etsu silicon KE420
 - Sika-cleaner 205

NOTE

- Sika product are made by Sika Corporation.
- Shin Etsu silicon KE420 is made by Shin Etsu Polymer Corporation.
- These materials can't be provided by Kubota Corporation.
- Therefore, please find the local made equivalent materials in your country and use them when you need.

9Y1210982CAS0067US0

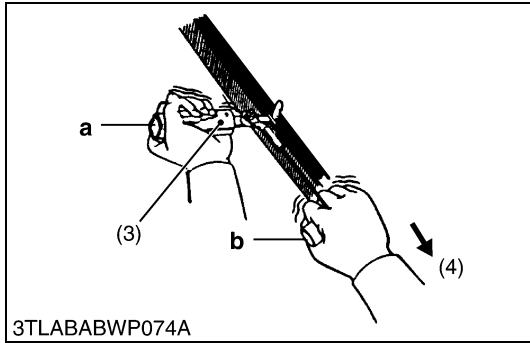
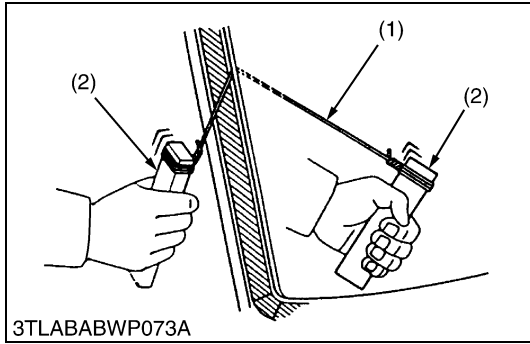

Before Replacing Windshields (1)

[In case of using piano wire (When glass is clacked)]

1. Thread the piano wire from the inside of cabin. Tie its both ends to a wooden blocks or the like. (See the left figure.)
2. Pull the piano wire inward/outward alternately to cut the adhered part.

■ **NOTE**

- Do not let the piano wire make sliding contact with the edge of glass plate forcibly.

[In case of using cutter knife (When glass is totally crushed finely)]

1. Insert the knife (3) into the adhered part.
2. Keep the edge of knife blade square to the glass edge at the part "a". Slide the knife blade along the glass surface and the edge. Pull the part "b" in the direction parallel to the glass edge to cut them off.

■ **NOTE**

- Find a wider gap between the glass and body.
- Be careful of handling the cutter knife not to damage your hand.

- | | |
|----------------|------------------|
| (1) Piano Wire | (3) Cutter Knife |
| (2) Wood Peace | (4) Pulling |

9Y1210982CAS0068US0

Before Replacing Windshields (2)

1. When the Sika Flex 250P-JM-1 or equivalent attached to the cabin frame and the glass are reused, remove the bond clearly.

■ **NOTE**

- Remove the bond completely.

9Y1210982CAS0069US0

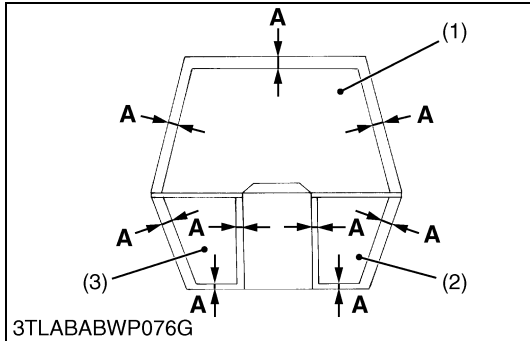

Before Replacing Windshields (3)

1. Check that the glasses are not damaged and cracked.
2. The cleaning area of the rear surface is indicated "A" in the figure left.

■ **NOTE**

- If not cleaning the glass, it may result in adhesive failure.

- | | |
|------------------------------|--|
| (1) Upper Windshield | A: 18 to 22 mm (0.71 to 0.87 in.) |
| (2) Lower Windshield (Left) | |
| (3) Lower Windshield (Right) | |

9Y1210982CAS0070US0

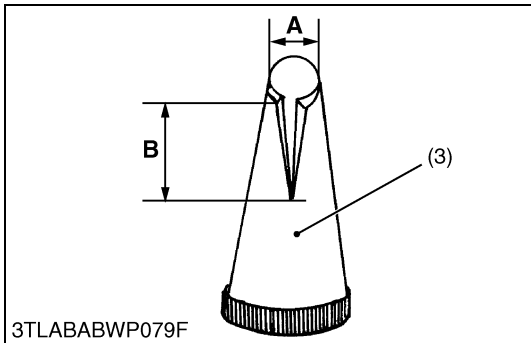
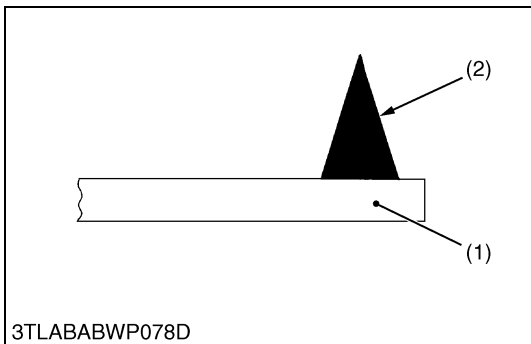
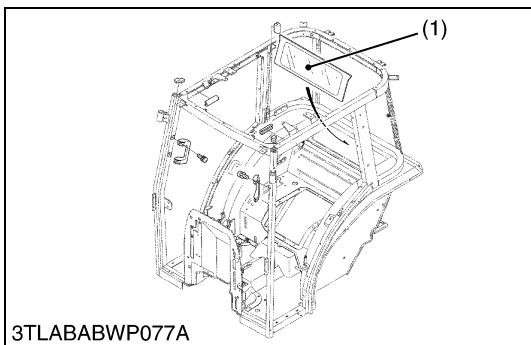

Rear Windshield

1. Apply a Sika primer 260P-JM-1 on the cabin frame.
2. Apply a Sika Flex 250P-JM-1 (or equivalent) on the rear windshield (1) as shown in figure.
3. Install the rear windshield (1) to the cabin and fix it with a gummed tape.
4. Leave it for one hour.

■ **NOTE**

- Apply the Sika Flex 250P-JM-1 (or equivalent) with the jig having the specified tip shape as shown in the figure left.
- Apply it with a uniform speed to minimize unevenness.
- Follow the instruction manual of Sika Flex 250P-JM-1.
- When the gummed tape is removed the rear windshield may be displaced. In this case fix it again.
- Remove the gummed tape (adhesive tape) little by little to make sure the bonding condition.

- | | |
|-------------------------|-------------------------------------|
| (1) Rear Windshield | A: 8 mm dia. (0.31 in. dia.) |
| (2) Sika Flex 250P-JM-1 | B: 12 mm (0.47 in.) |
| (3) Jig | |

9Y1210982CAS0071US0

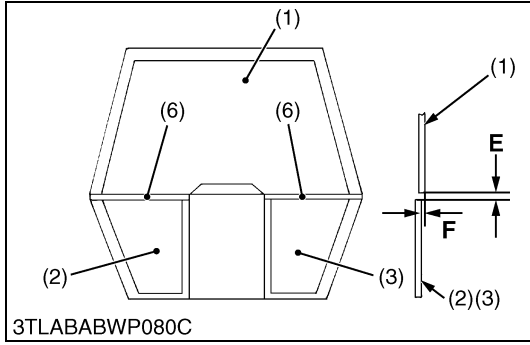
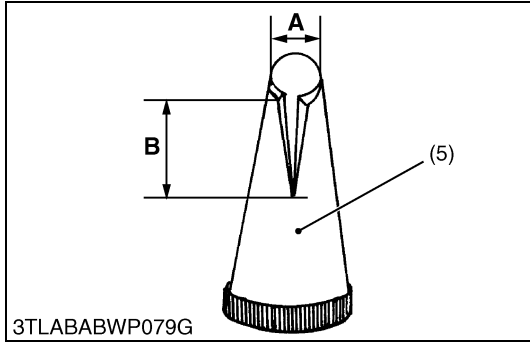
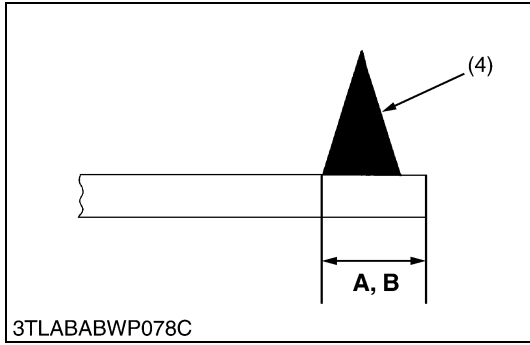
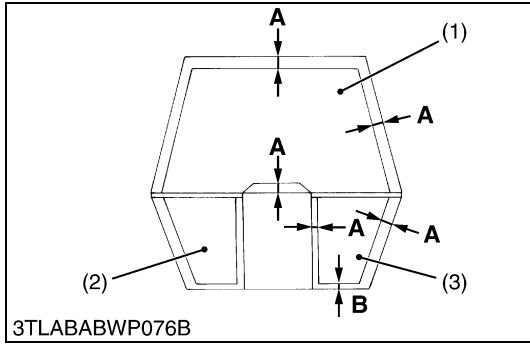

Front Windshield

■ **NOTE**

- Apply the Sika Flex 250P-JM-1 (or equivalent) with the jig having the specified tip shape as shown in the figure left.
- Apply it with a uniform speed to minimize unevenness.
- Follow the instruction manual of Sika Flex 250P-JM-1.

1. Apply the Sika Primer 260P-JM-1 on the cabin frame "A" and "B" in the figure.
2. Apply the Sika Flex 250P-JM-1 (4) on the windshield "A" and "B" in the figure.
3. Install the lower (left or right) windshield to the cabin and fix it with a gummed tape.
4. Set the upper windshield to the cabin and fix it with a gummed tape.

■ **NOTE**

- Use a jig (7) shown in the figure to create even clearance "E" [approx. 5 mm (0.2 in.)] between the lower and upper windshield.
- The level unevenness between the upper and lower windshields should be -1 to +1 mm (-0.04 to +0.04 in.) or less at the windshield surface.

5. Leave it for one hour.
6. Remove the jig (7).
7. Install the H rubber (6) between the lower and upper windshield (2), (3).
8. Apply the Shin Etsu silicon KE420 in H rubber (6).
9. Apply the Shin Etsu silicon KE420 on the edge of H rubber (6).

■ **NOTE**

- When the gummed tape is removed, the glass may be displaced. In this case fix it again.
- Remove the gummed tape (adhesive tape) little by little to make sure the bonding condition.

- | | |
|------------------------------|---|
| (1) Upper Windshield | A: 10 mm (0.39 in.) |
| (2) Lower Windshield (Right) | B: 12 mm (0.47 in.) |
| (3) Lower Windshield (Left) | C: 8 mm dia. (0.31 in. dia.) |
| (4) Sika Flex 250P-JM-1 | D: 12 mm (0.47 in.) |
| (5) Jig | E: 5 mm (0.2 in.) |
| (6) H Rubber | F: -1.0 to +1.0 mm (-0.04 to +0.04 in.) |
| (7) Jig | G: 360 mm (14.2 in.) |
| | H: 20 mm (0.8 in.) |
| | I: 5 mm (0.2 in.) |

9Y1210982CAS0072US0

(8) Wiper Motor

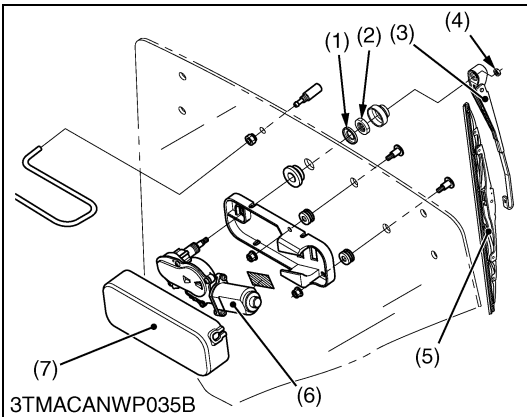
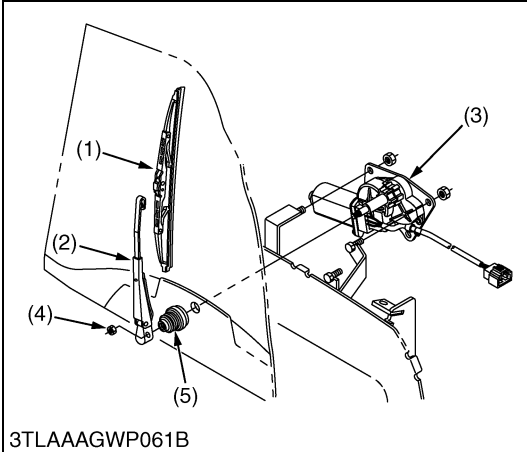
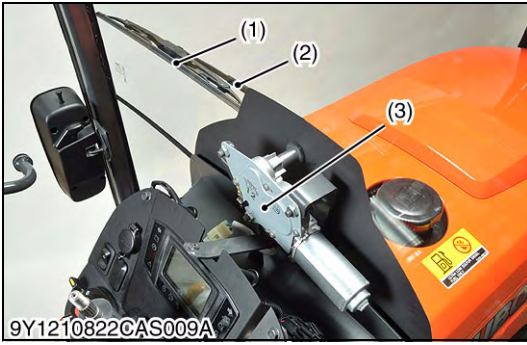

Front Wiper Motor

1. Remove the panel lower cover.
2. Disconnect the front wiper motor **4P** connector.
3. Remove the wiper arm mounting nut (4) and wiper arm (2).
4. Remove the wiper link cap (5).
5. Remove the front wiper motor (3).

(When reassembling)

- When attaching the wiper arm (2) to the wiper motor (3), assemble so that the dimensions are as given in the photo on the left. After doing so, check if the wiper wipes symmetrically on the left and right (bilateral symmetry).

Tightening torque	Wiper motor mounting nut	6.4 to 9.3 N·m 0.65 to 0.95 kgf·m 4.7 to 6.8 lbf·ft
-------------------	--------------------------	---

Wiper blade position	Factory specification	Approx. 150 mm 5.91 in.
----------------------	-----------------------	-------------------------------

- | | |
|-----------------------|--------------------|
| (1) Wiper Blade | (4) Nut |
| (2) Wiper Arm | (5) Wiper Link Cap |
| (3) Front Wiper Motor | |

9Y1210982CAS0073US0

Rear Wiper Motor (If equipped)

1. Remove the wiper motor cover (7).
2. Disconnect the **4P** connector from rear wiper motor (6).
3. Remove the wiper arm mounting nut (4) and wiper arm (3).
4. Remove the wiper link cap (1) and nut (2).
5. Remove the rear wiper motor mounting screws and the rear wiper motor (6).

Tightening torque	Wiper arm mounting nut	7.9 to 9.8 N·m 0.80 to 1.0 kgf·m 5.8 to 7.2 lbf·ft
	Wiper motor mounting screw	7.9 to 9.8 N·m 0.80 to 1.0 kgf·m 5.8 to 7.2 lbf·ft

- | | |
|--------------------|-----------------------|
| (1) Wiper Link Cap | (5) Wiper Blade |
| (2) Nut | (6) Rear Wiper Motor |
| (3) Wiper Arm | (7) Wiper Motor Cover |
| (4) Nut | |

9Y1210982CAS0074US0

[3] SERVICING

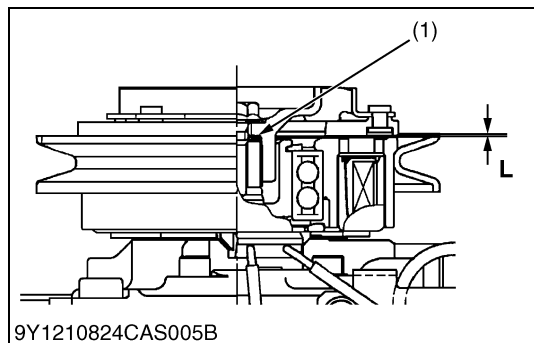

Adjustment of Air Gap

1. Measure the air gap with a feeler gauge.
2. When the measurement value comes off from factory specification, adjustment shim (1) is added or deleted.

Air gap (L)	Factory specification	0.30 to 0.65 mm 0.012 to 0.025 in.
-------------	-----------------------	---------------------------------------

(Reference)

Adjusting Shim Size	Code No.
0.10 mm (0.0039 in.)	T1065-87340
0.15 mm (0.0059 in.)	T1065-87350
0.40 mm (0.016 in.)	T1065-87360
0.60 mm (0.024 in.)	T1065-87370
1.00 mm (0.0394 in.)	T1065-87380

(1) Shim

L: Air Gap

9Y1210982CAS0075US0

EDITOR:

KUBOTA FARM & INDUSTRIAL MACHINERY SERVICE, LTD.

64, ISHIZU-KITAMACHI, SAKAI-KU, SAKAI-CITY, OSAKA, 590-0823, JAPAN

PHONE : (81)72-241-1129

FAX : (81)72-245-2484

E-mail : ks_g.ksos-pub@kubota.com
