

OPERATOR'S MANUAL

BX2350 S# 60964

KUBOTA TRACTOR

MODELS BX1850 • BX2350

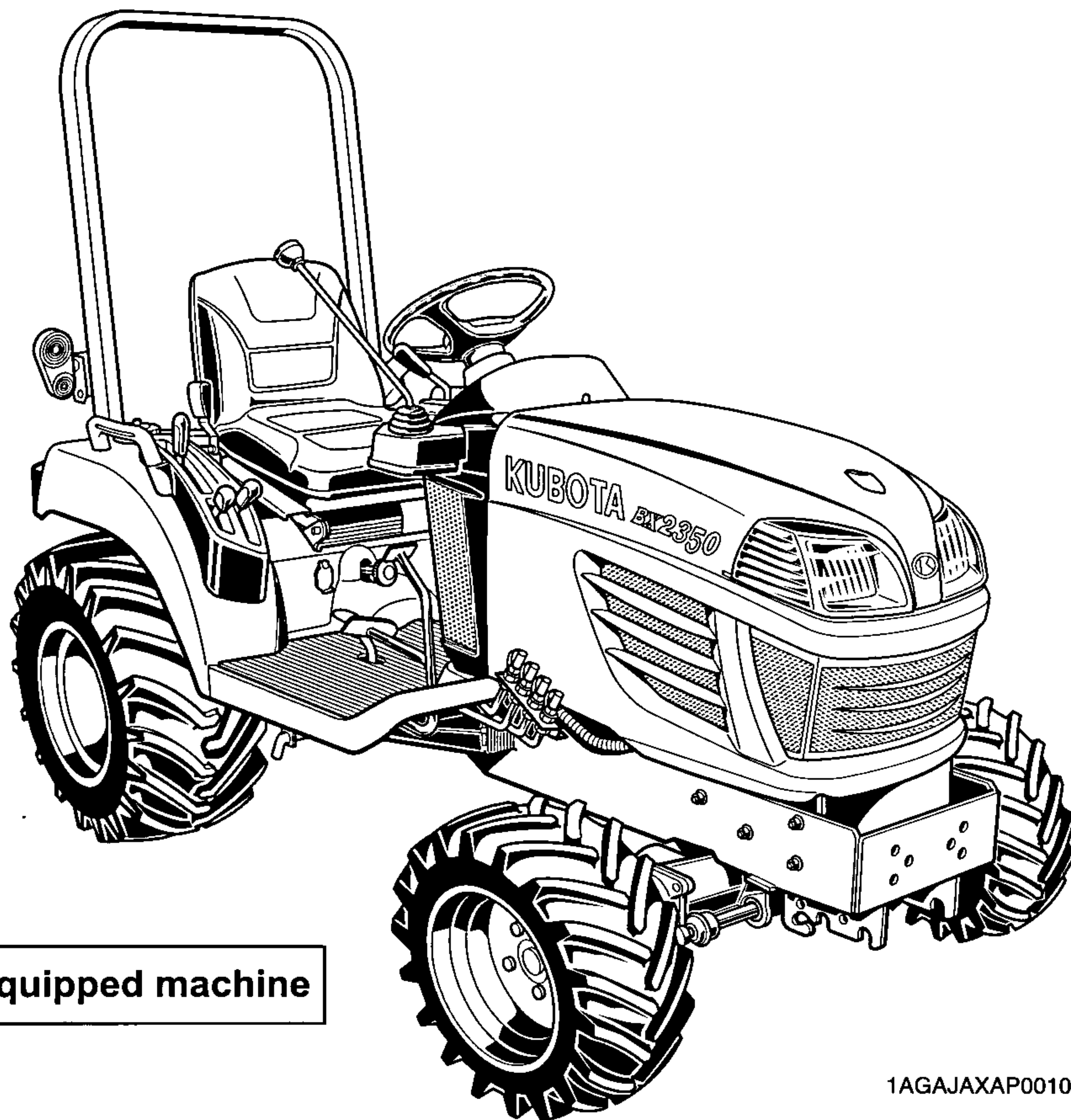

AUX. valve equipped machine

1AGAJAXAP0010

READ AND SAVE THIS MANUAL

Kubota

ABBREVIATION LIST

Abbreviations	Definitions
2WD	Two Wheel Drive
4WD	Four Wheel Drive
API	American Petroleum Institute
ASAE	American Society of Agricultural Engineers, USA
ASTM	American Society of Testing and Materials, USA
DIN	Deutsches Institut für Normung, GERMANY
DT	Dual Traction [4WD]
fpm	Feet Per Minute
GST	Glide Shift Transmission
Hi-Lo	High Speed-Low Speed
HST	Hydrostatic Transmission
m/s	Meters Per Second
PTO	Power Take Off
RH/LH	Right-hand and left-hand sides are determined by facing in the direction of forward travel
ROPS	Roll-Over Protective Structures
rpm	Revolutions Per Minute
rps	Revolutions Per Second
SAE	Society of Automotive Engineers, USA
SMV	Slow Moving Vehicle



























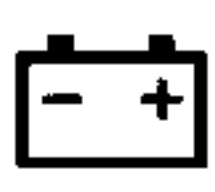



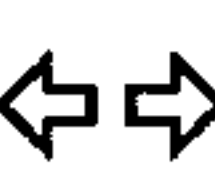

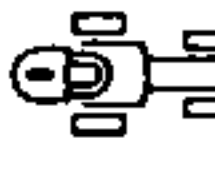

California Proposition 65

WARNING

The engine exhaust from this product contains chemicals known to the State of California to cause cancer, birth defects or other reproductive harm.

UNIVERSAL SYMBOLS

As a guide to the operation of your tractor, various universal symbols have been utilized on the instruments and controls. The symbols are shown below with an indication of their meaning.

	Safety Alert Symbol		3-Point Lowering Speed Control
	Diesel Fuel		Remote Cylinder-Retract
	Fuel-Level		Remote Cylinder-Extend
	Hourmeter/Elapsed Operating Hours		Hazard Warning Lights
	Engine Coolant-Temperature		Headlight
	Diesel Preheat/Glow Plugs(Low Temperature Start Aid)		Four-Wheel Drive-On
	Brake		Four-Wheel Drive-Off
	Parking Brake		Fast
	Battery Charging Condition		Slow
	Engine Oil-Pressure		Read Operator's Manual
	Turn Signal		Engine Speed Control
	Engine-Stop		Speed set-On
	Engine-Run		Speed set-Off
	Starter Control		Mid-PTO
	Power Take-Off Clutch Control-Off Position		Mid-Rear-PTO
	Power Take-Off Clutch Control-On Position		Rear-PTO
	Differential Lock		
	Hydraulic Control-Raised Position		
	Hydraulic Control-Lowered Position		

FOREWORD

You are now the proud owner of a KUBOTA Tractor. This tractor is a product of KUBOTA quality engineering and manufacturing. It is made of fine materials and under a rigid quality control system. It will give you long, satisfactory service. To obtain the best use of your tractor, please read this manual carefully. It will help you become familiar with the operation of the tractor and contains many helpful hints about tractor maintenance. It is KUBOTA's policy to utilize as quickly as possible every advance in our research. The immediate use of new techniques in the manufacture of products may cause some small parts of this manual to be outdated. KUBOTA distributors and dealers will have the most up-to-date information. Please do not hesitate to consult with them.



SAFETY FIRST

This symbol, the industry's "Safety Alert Symbol", is used throughout this manual and on labels on the machine itself to warn of the possibility of personal injury. Read these instructions carefully. It is essential that you read the instructions and safety regulations before you attempt to assemble or use this unit.



DANGER : Indicates an imminently hazardous situation which, if not avoided, will result in death or serious injury.



WARNING : Indicates a potentially hazardous situation which, if not avoided, could result in death or serious injury.



CAUTION: Indicates a potentially hazardous situation which, if not avoided, may result in minor or moderate injury.

IMPORTANT : Indicates that equipment or property damage could result if instructions are not followed.

NOTE : Gives helpful information.

CONTENTS

▲ SAFE OPERATION	1
SERVICING OF TRACTOR.....	1
SPECIFICATIONS.....	2
SPECIFICATION TABLE	2
TRAVELING SPEEDS	3
IMPLEMENT LIMITATIONS	4
INSTRUMENT PANEL AND CONTROLS.....	6
PRE-OPERATION CHECK	8
DAILY CHECK	8
OPERATING THE ENGINE.....	9
STARTING THE ENGINE	9
Cold Weather Starting	11
Block Heater (Option)	11
STOPPING THE ENGINE.....	11
WARMING UP	12
Warm-up and Transmission Oil in the Low Temperature Range.....	12
JUMP STARTING	12
OPERATING THE TRACTOR.....	13
OPERATING NEW TRACTOR	13
Do not Operate the Tractor at Full Speed for the First 50 Hours.....	13
Changing Lubricating Oil for New Tractors.....	13
STARTING	13
Operator's Seat.....	13
Seat Belt	14
Head Light Switch.....	14
Hazard Light Switch.....	14
Turn Signal Light Switch.....	14
Brake Pedal	14
Range Gear Shift Lever (Hi-Lo).....	15
Front Wheel Drive Lever.....	15
Hand Throttle Lever	16
Parking Brake Pedal.....	16
Speed Control Pedal.....	16
Speed Set Device (BX2350).....	17
STOPPING.....	17
Stopping.....	17
CHECK DURING DRIVING	18
Immediately Stop the Engine if:	18
Easy Checker(TM).....	18
Fuel Gauge.....	18
Coolant Temperature Gauge	18
Hourmeter/Tachometer.....	19
PARKING	19

CONTENTS

Parking.....	19
ACCESSORY.....	20
12V Electric Outlet.....	20
Operator's Manual Holder.....	20
OPERATING TECHNIQUES	20
Differential Lock.....	20
Operating the Tractor on a Road.....	21
Operating on a Slopes and Rough Terrain.....	21
Directions for Use of Power Steering.....	21
PTO	22
PTO OPERATION.....	22
PTO Select Lever	22
PTO Clutch Lever	23
PTO Shaft Cover and Shaft Cap	23
Stationary PTO	24
PTO Drive Shaft.....	24
THREE-POINT HITCH & DRAWBAR.....	25
3 -POINT HITCH	26
Attaching and detaching implements.....	26
Lifting Rod (Right).....	26
Top Link.....	26
Check Chains	26
HITCH	26
HYDRAULIC UNIT.....	27
3-POINT HITCH CONTROL SYSTEM.....	27
Hydraulic Control	27
3-point Hitch Lowering Speed.....	27
AUXILIARY HYDRAULICS	28
Hydraulic Outlet	28
MOWER LIFT LINKAGE SYSTEM	28
Cutting Height Control Dial	28
Hydraulic Control Unit Use Reference Chart.....	29
AUXILIARY HYDRAULIC CONTROL VALVE (IF EQUIPPED).....	30
Valve Lock.....	30
Auxiliary Hydraulic Ports.....	30
Auxiliary Hydraulic Control Lever.....	31
TIRES, WHEELS AND BALLAST.....	32
TIRES.....	32
Inflation Pressure.....	32
WHEEL TREAD	32
Front Wheels	32
Rear Wheels.....	33
BALLAST	34
Front Ballast.....	34
Rear Ballast	34
MAINTENANCE.....	35
SERVICE INTERVALS	35
LUBRICANTS	37

PERIODIC SERVICE.....	38
HOW TO OPEN THE HOOD	38
Hood	38
Engine Cover	38
DAILY CHECK	39
Walk Around Inspection.....	39
Checking and Refueling.....	39
Checking Engine Oil Level.....	40
Checking Transmission Fluid Level	41
Checking Coolant Level.....	41
Cleaning Panel and Radiator Screen	42
Checking Brake Pedal	42
Checking Gauges, Meter and Easy Checker(TM).....	42
Checking Head Light, Hazard Light etc.	42
Checking Seat Belt and ROPS	42
Checking and Cleaning of Electrical Wiring and Battery Cables	43
EVERY 50 HOURS	43
Lubricating Grease Fittings.....	43
Checking Engine Start System	44
Checking Wheel Bolt Torque	45
EVERY 100 HOURS	45
Battery	45
Changing Engine Oil.....	47
Cleaning Air Cleaner Element	48
Checking Fuel Lines and Fuel Filter	48
Adjusting Fan Belt Tension.....	49
Adjusting HST Neutral Spring (for Speed Control Pedal).....	49
Adjusting Brake Pedal	50
EVERY 200 HOURS	50
Replacing Engine Oil Filter	50
Checking Radiator Hoses and Clamps.....	51
Checking Intake Air Line.....	51
Adjusting Toe-in.....	52
Checking Power Steering Line	52
EVERY 300 HOURS	53
Changing Transmission Fluid	53
Cleaning Transmission Strainer.....	53
Replacing Transmission Oil Filter	54
Changing Front Axle Case Oil	54
EVERY 400 HOURS	55
Adjusting Front Axle Pivot.....	55
EVERY 500 HOURS	55
Replacing Fuel Filter Element.....	55
EVERY 800 HOURS	55
Adjusting Engine Valve Clearance	55
EVERY 1500 HOURS	55
Checking Fuel Injection Nozzle Injection Pressure.....	55
EVERY 3000 HOURS	55
Checking Injection Pump.....	55
EVERY 1 YEAR	55
Replacing Air Cleaner Element.....	55

CONTENTS

EVERY 2 YEARS.....	55
Flush Cooling System and Changing Coolant.....	55
Anti-Freeze	56
Replacing Radiator Hose (Water pipes)	57
Replacing Power Steering Hose.....	57
Replacing Fuel Lines	57
Replacing Intake Air Line.....	57
SERVICE AS REQUIRED.....	57
Bleeding Fuel System.....	57
Replacing Fuse.....	58
Replacing Light Bulb.....	58
STORAGE	59
TRACTOR STORAGE	59
REMOVING THE TRACTOR FROM STORAGE.....	59
TROUBLESHOOTING.....	60
ENGINE TROUBLESHOOTING	60
OPTIONS.....	61



SAFE OPERATION

Careful operation is your best insurance against an accident.

Read and understand this manual carefully before operating the tractor.

All operators, no matter how much experience they may have, should read this and other related manuals before operating the tractor or any implement attached to it. It is the owner's obligation to instruct all operators in safe operation.

1. BEFORE OPERATING THE TRACTOR

1. Know your equipment and its limitations. Read this entire manual before attempting to start and operate the tractor.
2. Pay special attention to the danger, warning and caution labels on the tractor.
3. KUBOTA recommends the use of a CAB or Roll Over Protective Structures (ROPS) and seat belt in almost all applications. This combination will reduce the risk of serious injury or death, should the tractor be upset. If the CAB or ROPS is loosened or removed for any reason, make sure that all parts are reinstalled correctly before operating the tractor. Never modify or repair a CAB or ROPS because welding, bending, drilling, grinding, or cutting may weaken the structure. A damaged CAB or ROPS structure must be replaced, not repaired or revised. If any structural member of the CAB or ROPS is damaged, replace the entire structure at your local KUBOTA Dealer.

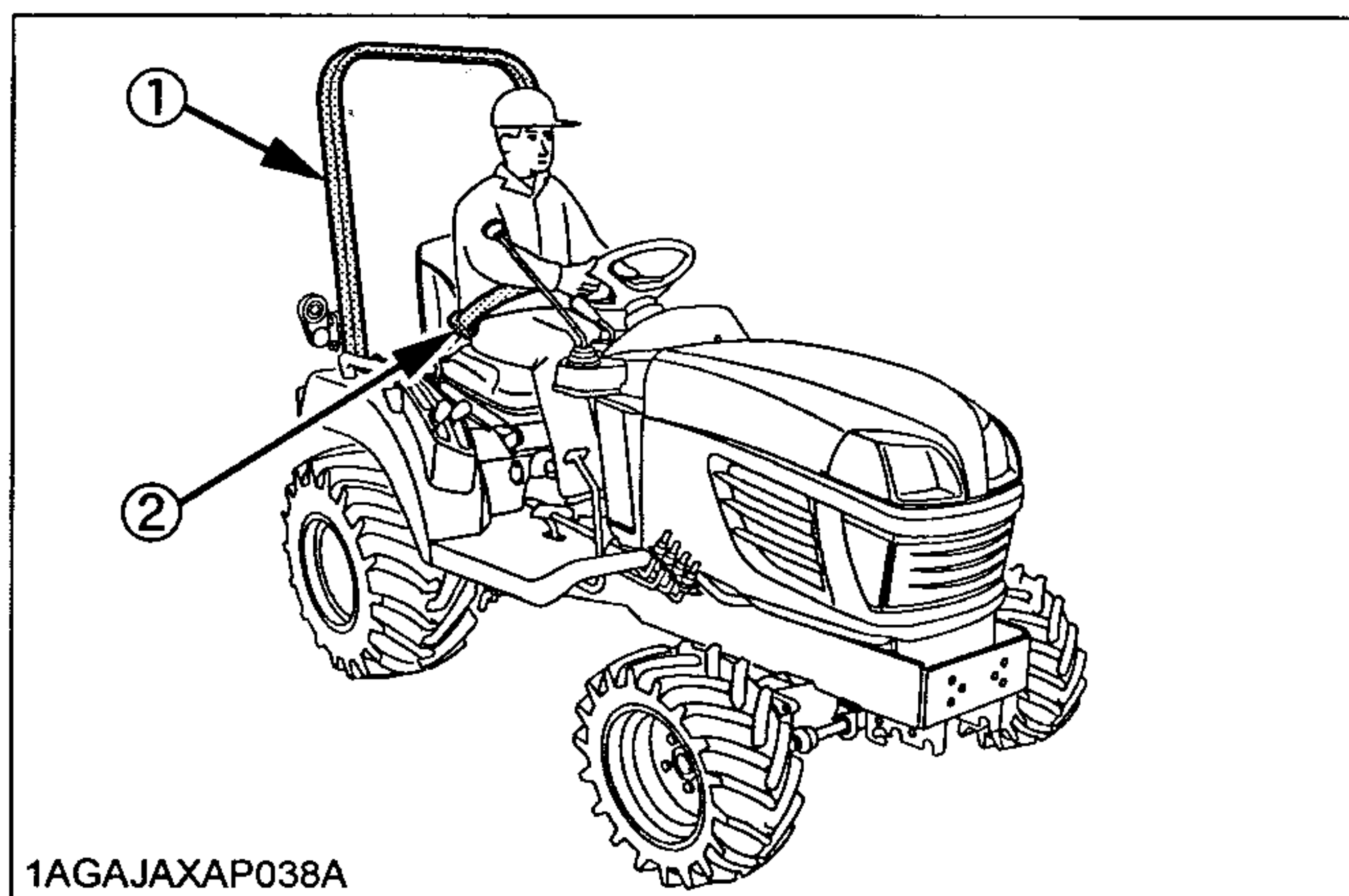

(1) ROPS
(2) Seat belt

4. Always use the seat belt if the tractor has a CAB or ROPS. Do not use the seat belt if there is no CAB or ROPS. Check the seat belt regularly and replace if frayed or damaged.

5. Do not operate tractor or any implement attached to it while under the influence of alcohol, medication, controlled substances or while fatigued.
6. Carefully check the vicinity before operating tractor or any implement attached to it. Check for overhead clearance which may interfere with a CAB or ROPS. Do not allow any bystanders around or near tractor during operation.
7. Before allowing other people to use your tractor, explain how to operate and have them read this manual before operation.
8. Never wear loose, torn, or bulky clothing around tractor. It may catch on moving parts or controls, leading to the risk of an accident. Use additional safety items, e.g. hard hat, safety boots or shoes, eye and hearing protection, gloves, etc., as appropriate or required.
9. Do not allow passengers to ride on any part of the tractor at anytime. The operator must remain in the tractor seat during operation.
10. Check brakes, and other mechanical parts for improper adjustment and wear. Replace worn or damaged parts promptly. Check the tightness of all nuts and bolts regularly. (For further details, see "MAINTENANCE" section.)
11. Keep your tractor clean. Dirt, grease, and trash build up may contribute to fires and lead to personal injury.
12. Use only implements meeting the specifications listed under "IMPLEMENT LIMITATIONS" in this manual or implements approved by KUBOTA.
13. Use proper weights on the front or rear of the tractor to reduce the risk of upsets. When using the front loader, put an implement or ballast on the 3-point hitch to improve stability. Follow the safe operating procedures specified in the implement or attachment manual.
14. Do not modify the tractor. Unauthorized modification may affect the function of the tractor, which may result in personal injury.

2. OPERATING THE TRACTOR

◆ Starting

1. Always sit in the operator's seat when starting engine or operating levers or controls.
2. Before starting the engine, make sure that all levers (including auxiliary control levers) are in their neutral positions, that the parking brake is engaged, and that the Power Take-Off (PTO) is disengaged or "OFF". Fasten the seat belt if the tractor has a CAB, a fixed ROPS or a foldable ROPS in the upright and locked position.
3. Do not start engine by shorting across starter terminals or bypassing the safety start switch. Machine may start in gear and move if normal starting circuitry is bypassed.
4. Do not operate or idle engine in a non-ventilated area. Carbon monoxide gas is colorless, odorless, and deadly.
5. Check before each use that operator presence controls are functioning correctly. Test safety systems. (See "EVERY 50 HOURS, Checking Engine Start System" in "PERIODIC SERVICE" section) Do not operate unless they are functioning correctly.

◆ Working

1. Pull only from the hitch. Never hitch to axle housing or any other point except hitch; such arrangements will increase the risk of serious personal injury or death due to a tractor upset.

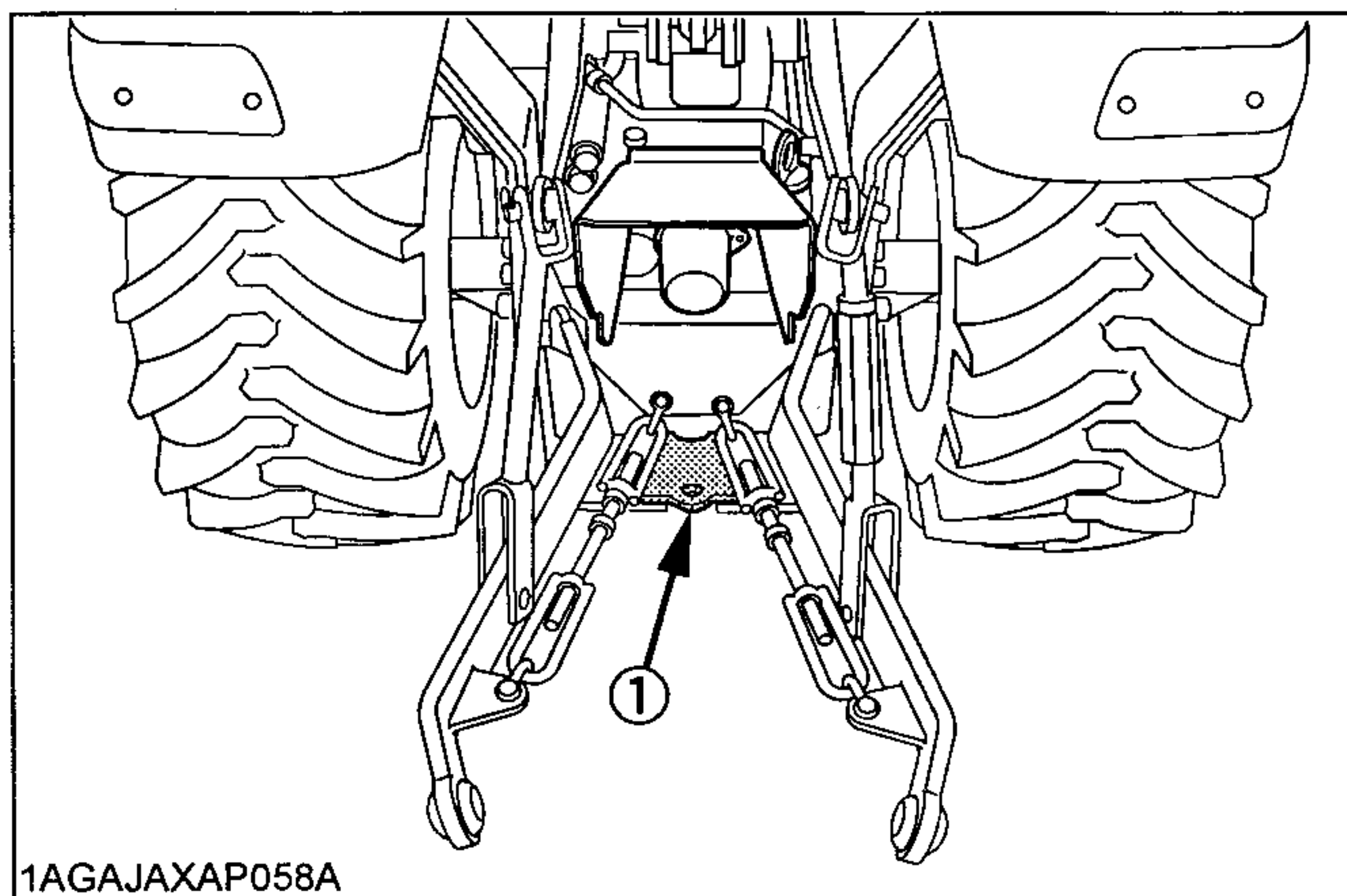

(1) Hitch

2. Keep all shields and guards in place. Replace any that are missing or damaged.
3. Avoid sudden starts. To avoid upsets, slow down when turning, on uneven ground, and before stopping.
4. The tractor cannot turn with the differential locked and attempting to do so could be dangerous.

5. Do not operate near ditches, holes, embankments, or other ground surface features which may collapse under the tractor's weight. The risk of tractor upset is even higher when the ground is loose or wet. Tall grass can hide obstacles, walk the area first to be sure.
6. Watch where you are going at all times. Watch for and avoid obstacles. Be alert at row ends, near trees, and other obstructions.
7. When working in groups, always let the others know what you are going to do before you do it.
8. Never try to get on or off a moving tractor.

◆ Safety for children

Tragedy can occur if the operator is not alert to the presence of children. Children generally are attracted to machines and the work they do.

1. Never assume that children will remain where you last saw them.
2. Keep children out of the work area and under the watchful eye of another responsible adult.
3. Be alert and shut your machine down if children enter the work area.
4. Never carry children on your machine. There is no safe place for them to ride. They may fall off and be run over or interfere with your control of the machine.
5. Never allow children to operate the machine even under adult supervision.
6. Never allow children to play on the machine or on the implement.
7. Use extra caution when backing up. Look behind and down to make sure area is clear before moving.
8. When parking your machine if at all possible park on a firm, flat and level surface; if not, park across a slope. Set the parking brake(s), lower the implements to the ground, remove the key from the ignition and lock the cab door (if equipped) and chock the wheels.

◆ Operating on slopes

Slopes are major factor related to loss-of-control and tip-over accidents, which can result in severe injury or death. All slopes require extra caution.

1. To avoid upsets, always back up steep slopes. If you cannot back up the slope or if you feel uneasy on it, do not operate on it. Stay off slopes too steep for safe operation.
2. Driving forward out of a ditch, mired condition or up a steep slope increases the risk of a tractor to be upset backward. Always back out of these situations. Extra caution is required with four-wheel drive models because their increased traction can give the operator false confidence in the tractor's ability to climb slopes.
3. Keep all movement on slopes slow and gradual. Do not make sudden changes in speed or direction.
4. Avoid disengaging the changing gears speed when climbing or going down a slope. If on a slope disengaging the changing gears to neutral could cause loss of control.

◆ Driving the tractor on the road

1. Check the front wheel engagement. The braking characteristics are different between two and four wheel drive. Be aware of the difference and use carefully.
2. Always slow the tractor down before turning. Turning at high speed may tip the tractor over.
3. Make sure that the Slow Moving Vehicle (SMV) sign is clean and visible. Use hazard lights and turn signals as required.

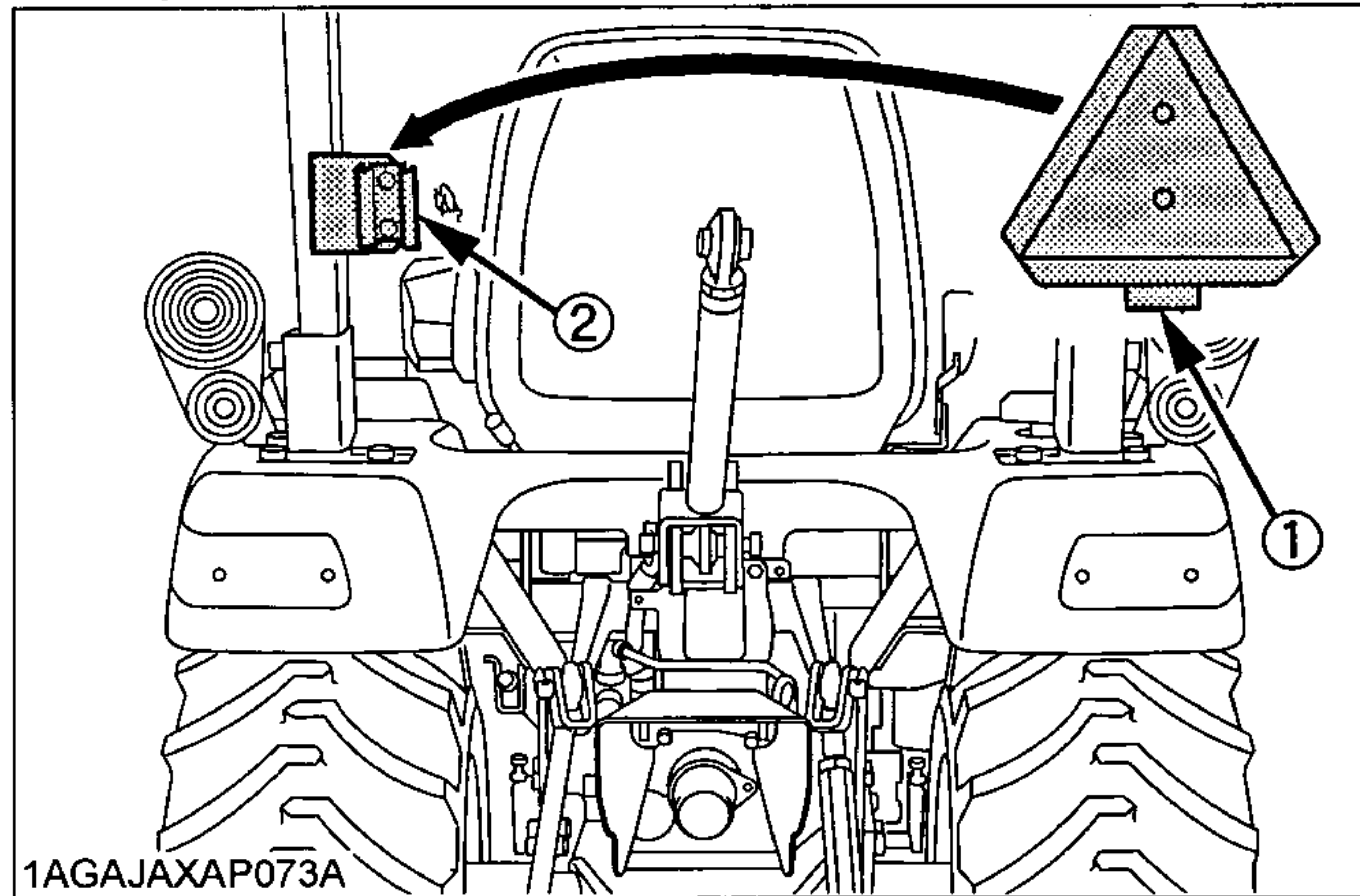

- (1) SMV emblem
(2) Bracket

4. Observe all local traffic and safety regulations.
5. Turn the headlights on.
6. Drive at speeds that allow you to maintain control at all times.
7. Do not apply the differential lock while traveling at road speeds. The tractor may run out of control.
8. Avoid sudden motions of the steering wheel as they can lead to a dangerous loss of stability. The risk is especially great when the tractor is traveling at road speeds.
9. Do not operate an implement while the tractor is on the road. Lock the 3-point hitch in the raised position.
10. When towing other equipment, use a safety chain and place an SMV emblem on it as well.

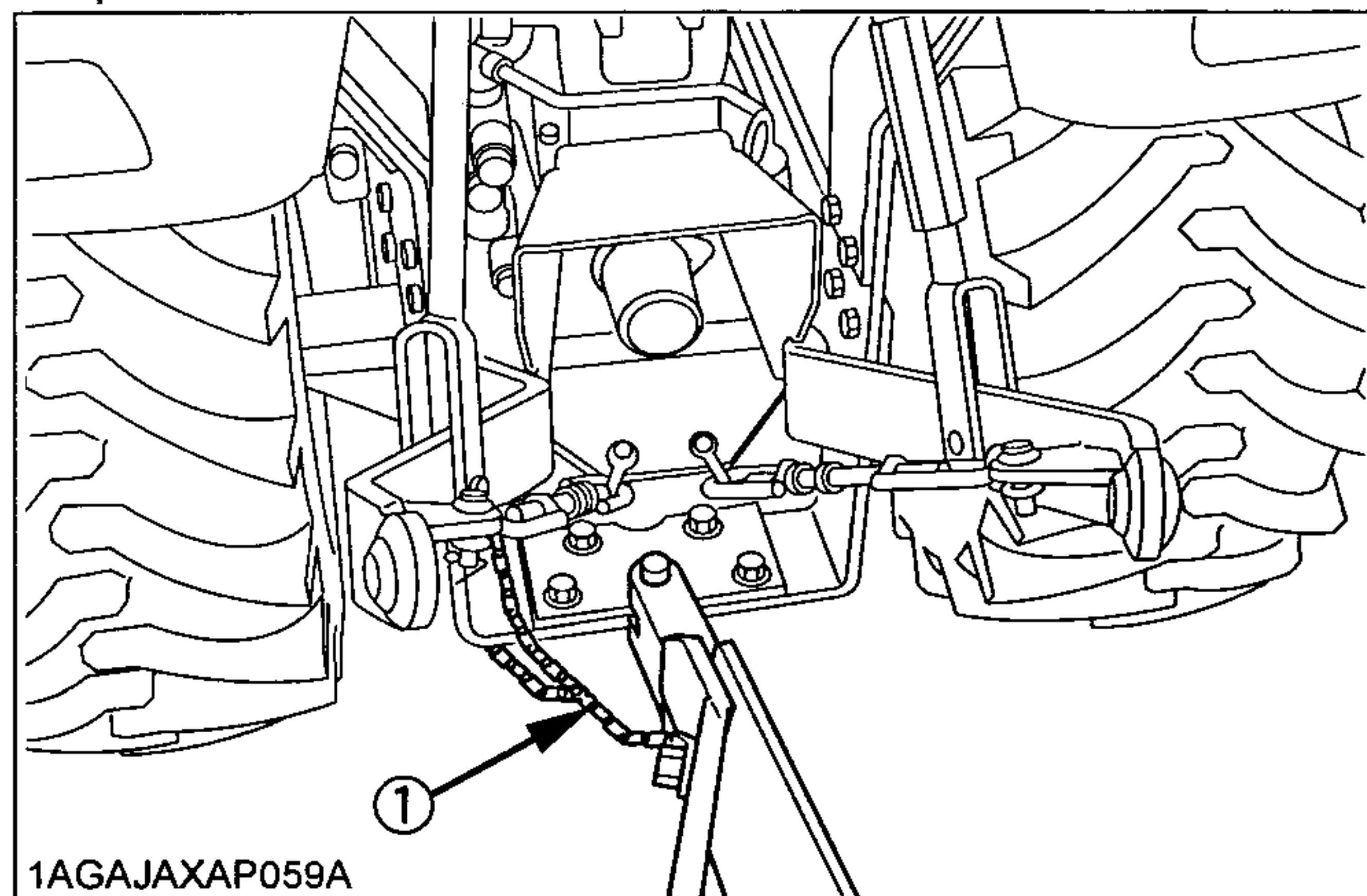

- (1) Safety chain

3. PARKING THE TRACTOR

1. Disengage the PTO, lower all implements to the ground, place all control levers in their neutral positions, set the parking brake, stop the engine, and remove the key.

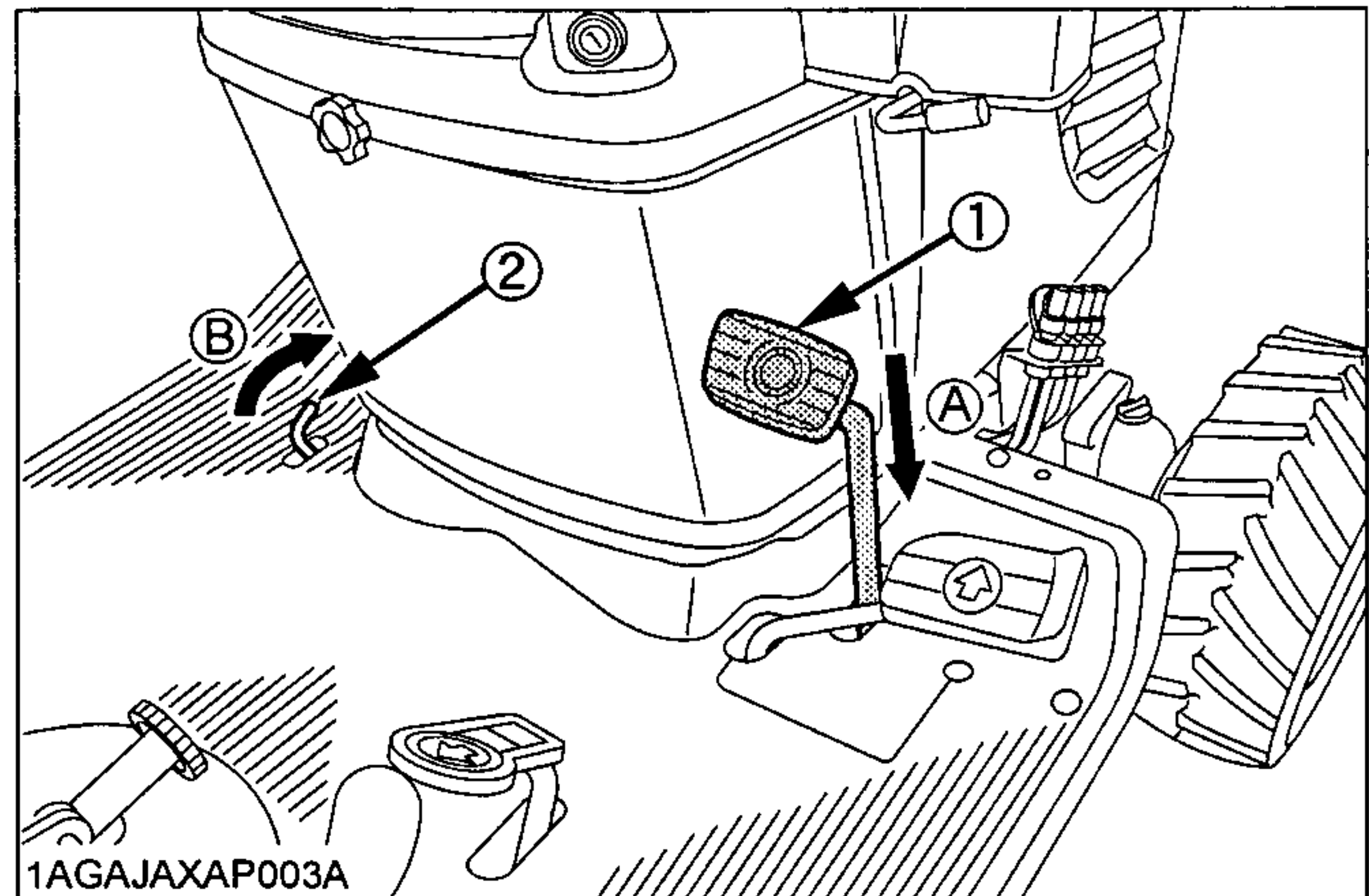

- (1) Brake pedal
(2) Parking brake pedal
(A) "DEPRESS"
(B) "PUSH FORWARD WHILE DEPRESSING (1)"

2. Make sure that the tractor has come to a complete stop before dismounting.
3. Avoid parking on steep slopes, if possible park on flat ground, if not, park across a slope, always with attachment on the ground.

4. OPERATING THE PTO

1. Wait until all moving components have completely stopped before getting off the tractor, connecting, disconnecting, adjusting, cleaning, or servicing any PTO driven equipment.
2. Keep the PTO shaft cover in place at all times. Replace the PTO shaft cap when the shaft is not in use.

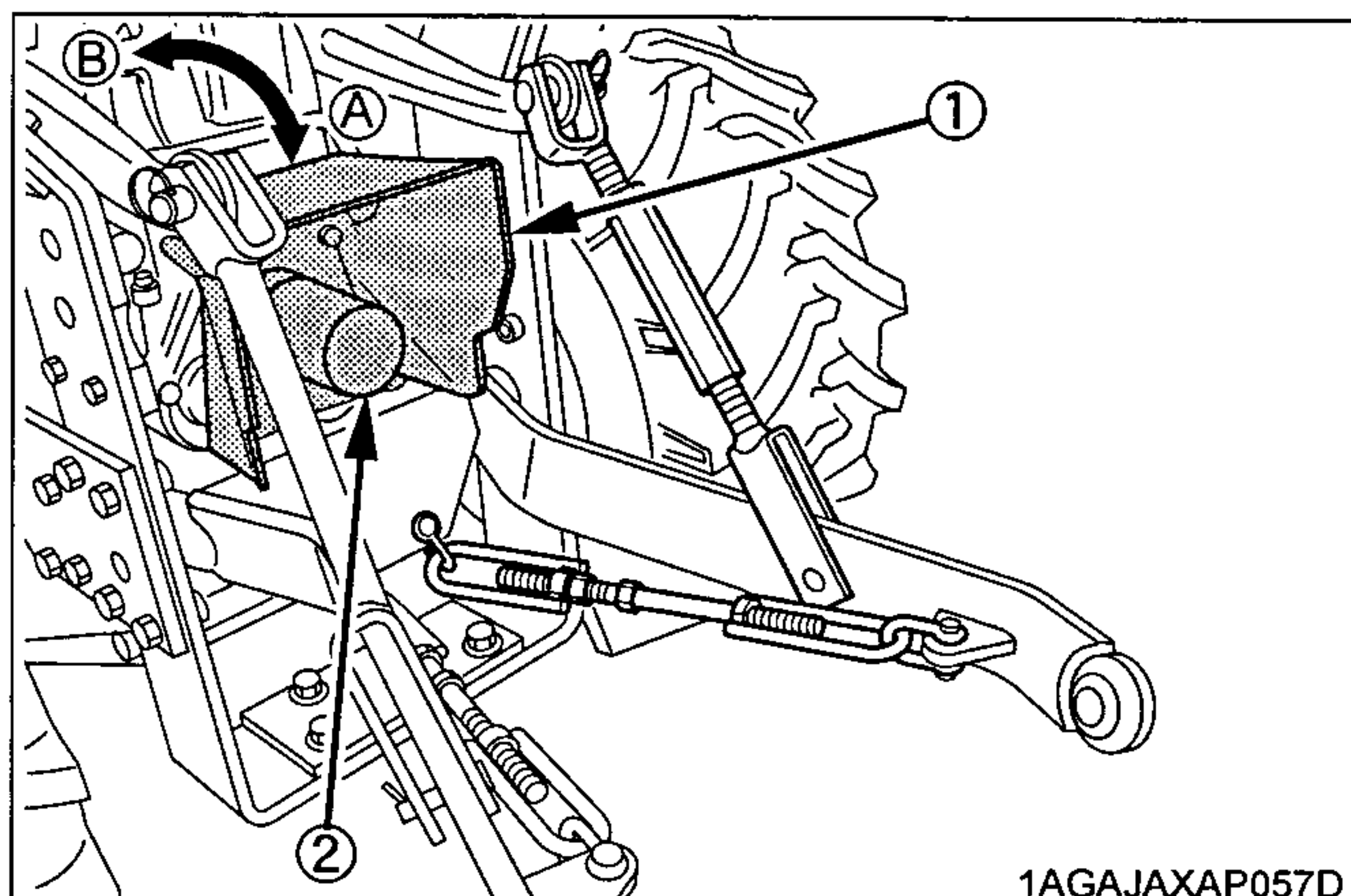

- (1) PTO Shaft cover (A) "NORMAL POSITION"
 (2) PTO Shaft cap (B) "RAISED POSITION"

3. Before installing or using PTO driven equipment, read the manufacturer's manual and review the safety labels attached to the equipment.
4. When operating stationary PTO driven equipment, always apply the tractor parking brake and place chocks behind and in front of the rear wheels. Stay clear of all rotating parts. Never step over rotating parts.

5. USING 3-POINT HITCH

1. Use the 3-point hitch only with equipment designed for 3-point hitch usage.
2. When using a 3-point hitch mounted implement, be sure to install the proper counterbalance weight on the front of the tractor.
3. When transporting on the road, set the implement lowering speed knob in the "LOCK" position to hold the implement in the raised position.

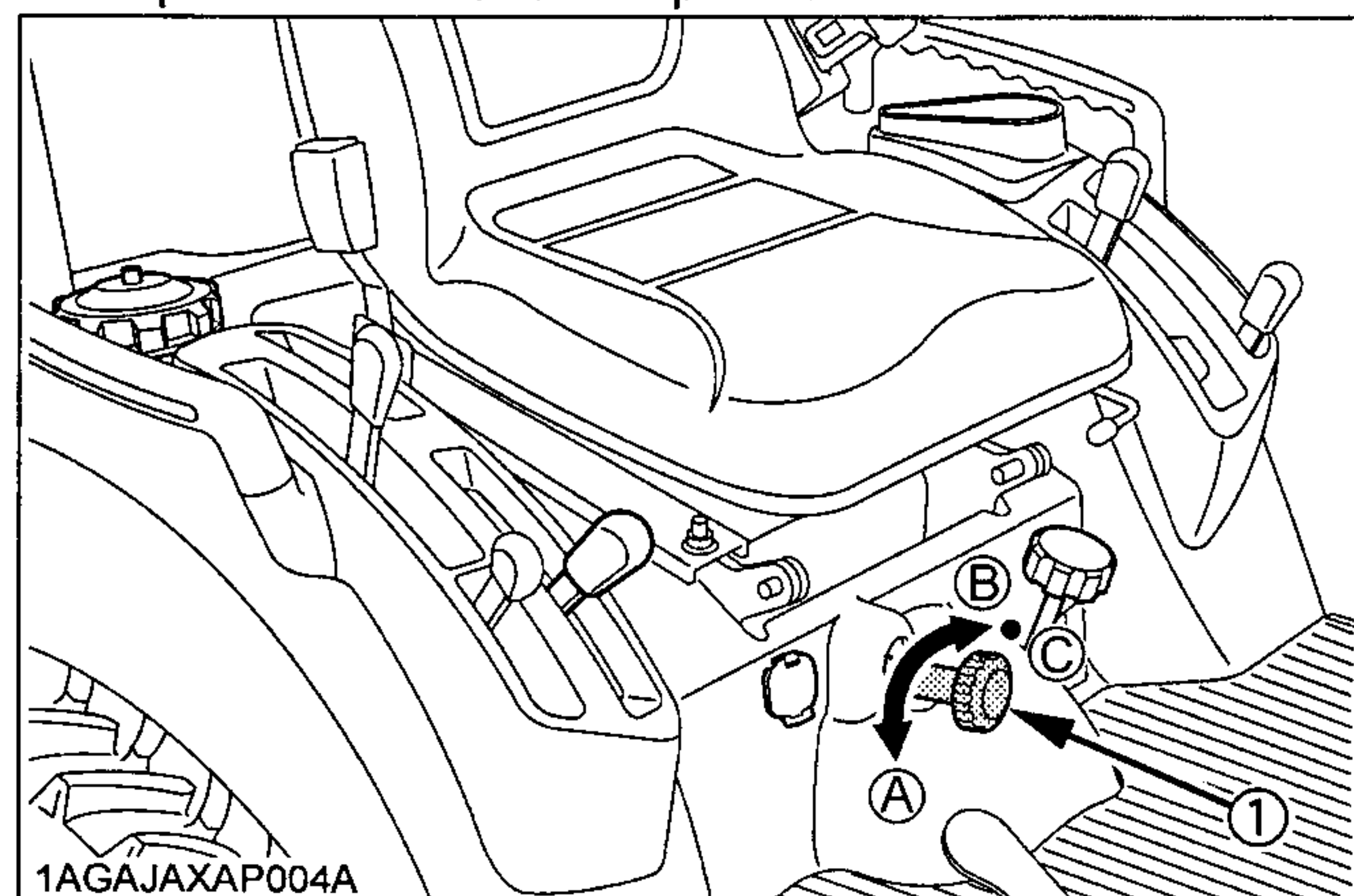

- (1) 3-point hitch lowering speed knob (A) "FAST"
 (B) "SLOW"
 (C) "LOCK"

6. SERVICING THE TRACTOR

Before servicing the tractor, park it on a firm, flat and level surface, set the parking brake, lower all implements to the ground, place the gear shift lever in neutral, stop the engine and remove the key.

1. Allow the tractor time to cool off before working on or near the engine, muffler, radiator, etc.
2. Always stop the engine before refueling. Avoid spills and overfilling.
3. Do not smoke when working around battery or when refueling. Keep all sparks and flames away from battery and fuel tank. The battery presents an explosive hazard, because it gives off hydrogen and oxygen especially when recharging.
4. Before "jump starting" a dead battery, read and follow all of the instructions. (See "JUMP STARTING" in "OPERATING THE ENGINE" section)
5. Keep first aid kit and fire extinguisher handy at all times.
6. Do not remove radiator cap while coolant is hot. When cool, slowly rotate cap to the first stop and allow sufficient time for excess pressure to escape before removing the cap completely. If the tractor has a coolant recovery tank, add coolant or water to the tank, not the radiator. (See "CHECKING COOLANT LEVEL" in "MAINTENANCE" section)

7. Disconnect the battery's ground cable before working on or near electric components.
8. To avoid the possibility of battery explosion, do not use or charge the refillable type battery if the fluid level is below the LOWER (lower limit level) mark. Check the fluid level regularly and add distilled water as required so that the fluid level between the UPPER and LOWER levels.
9. To avoid sparks from an accidental short circuit, always disconnect the battery's ground cable (-) first and reconnect it last.

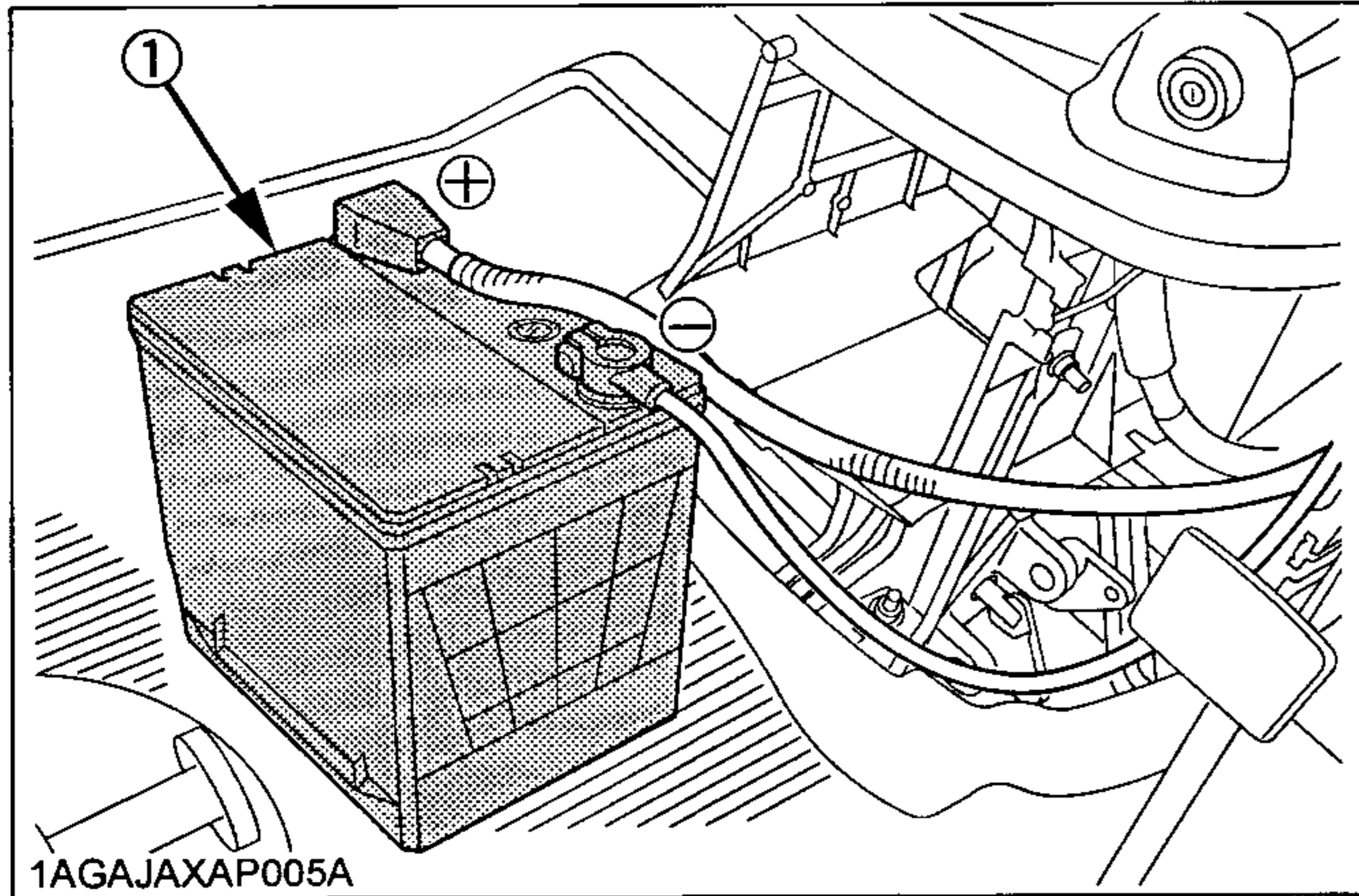

(1) Battery

10. Do not attempt to mount a tire on a rim. This should be done by a qualified person with the proper equipment.
11. Always maintain the correct tire pressure. Do not inflate tires above the recommended pressure shown in the operator's manual.

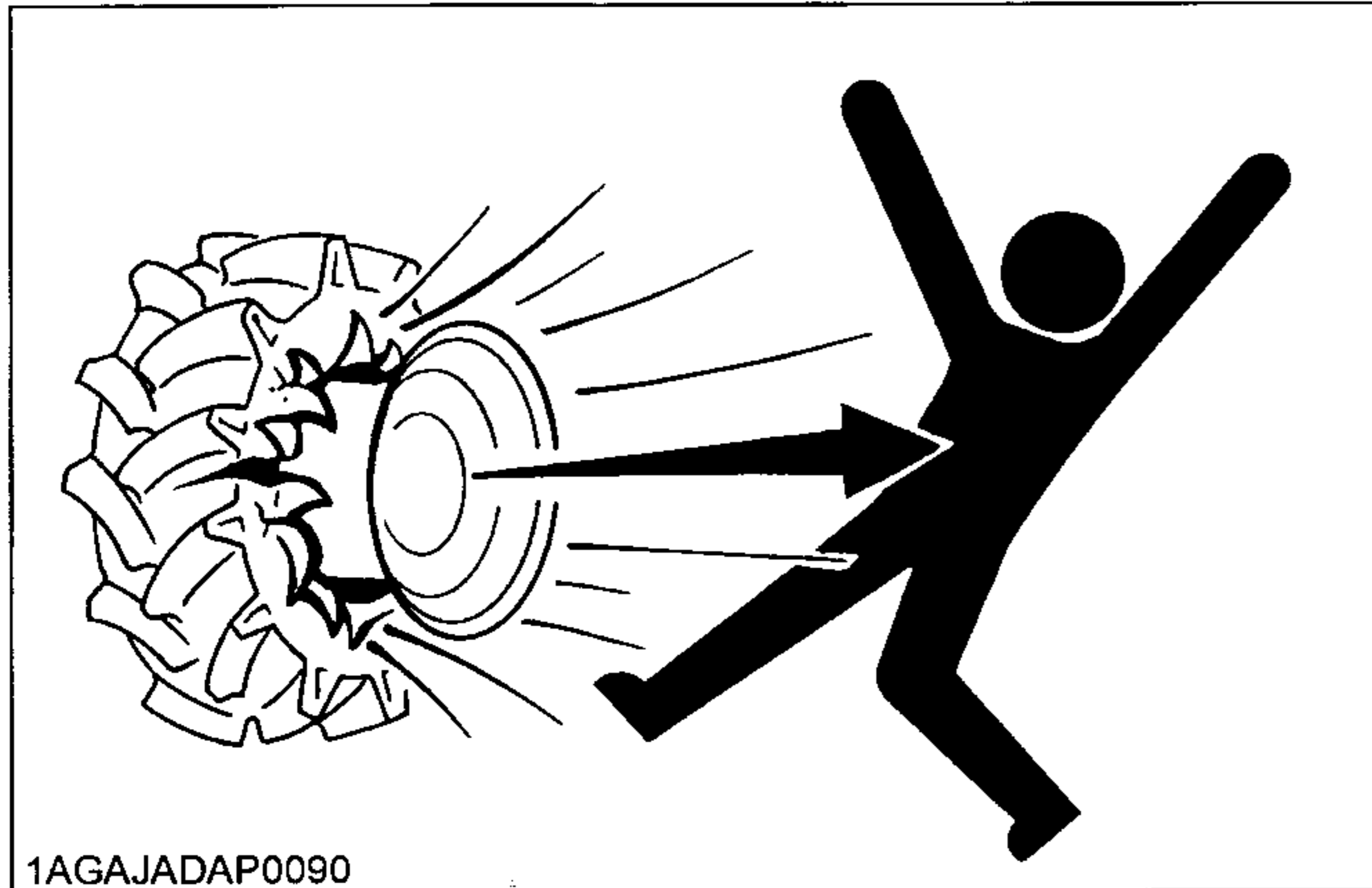

12. Securely support the tractor when either changing wheels or adjusting the wheel tread width.
13. Make sure that wheel bolts have been tightened to the specified torque.
14. Do not work under any hydraulically supported devices. They can settle, suddenly leak down, or be accidentally lowered. If it is necessary to work under tractor or any machine elements for servicing or adjustment, securely support them with stands or suitable blocking beforehand.

15. Escaping hydraulic fluid under pressure has sufficient force to penetrate skin, causing serious personal injury. Before disconnecting hydraulic lines, be sure to release all residual pressure. Before applying pressure to the hydraulic system, make sure that all connections are tight and that all lines, pipes, and hoses are free of damage.

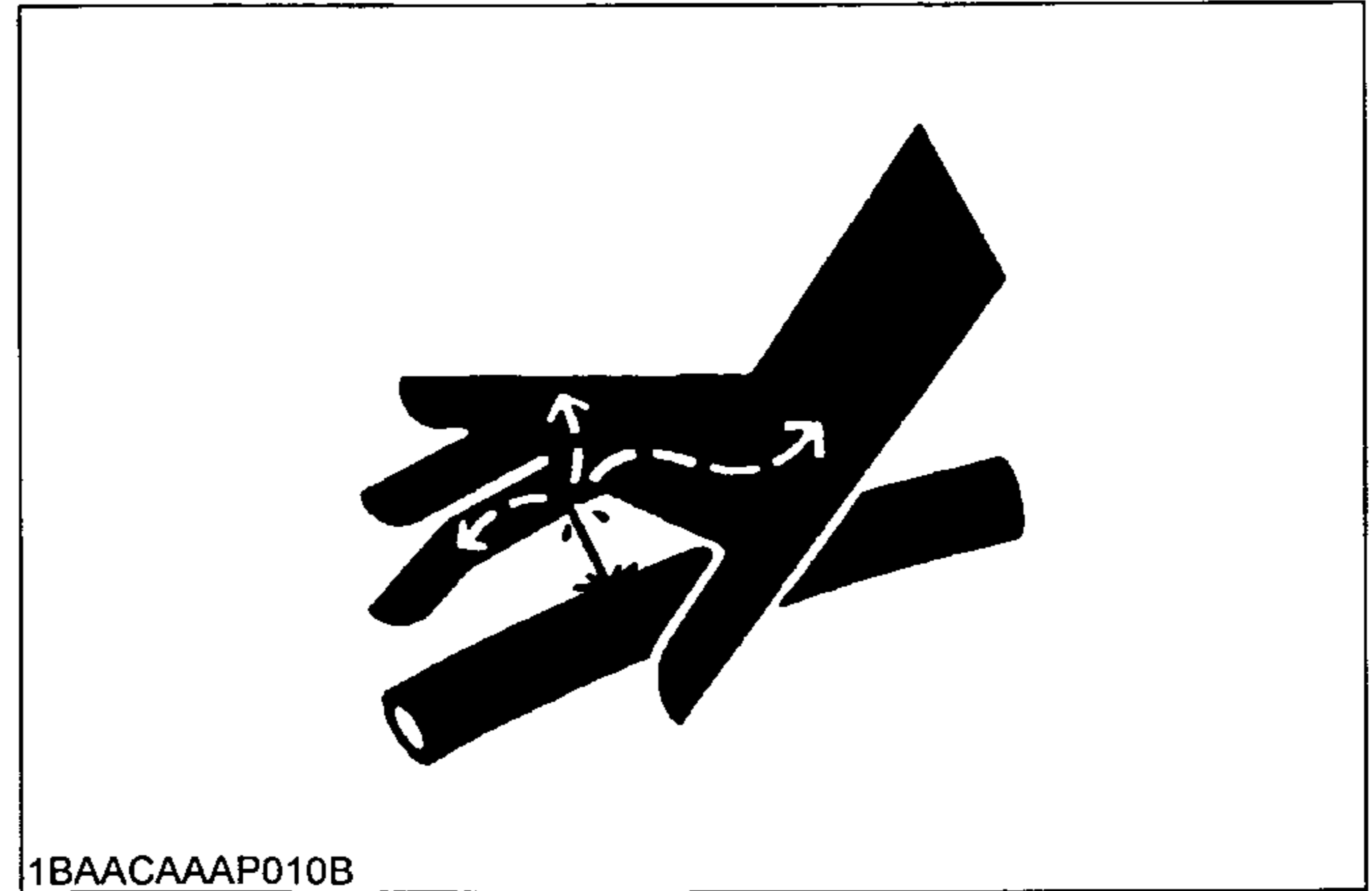

16. Fluid escaping from pinholes may be invisible. Do not use hands to search for suspected leaks; use a piece of cardboard or wood. Use of safety goggles or other eye protection is also highly recommended. If injured by escaping fluid, see a medical doctor at once. This fluid will produce gangrene or severe allergic reaction.

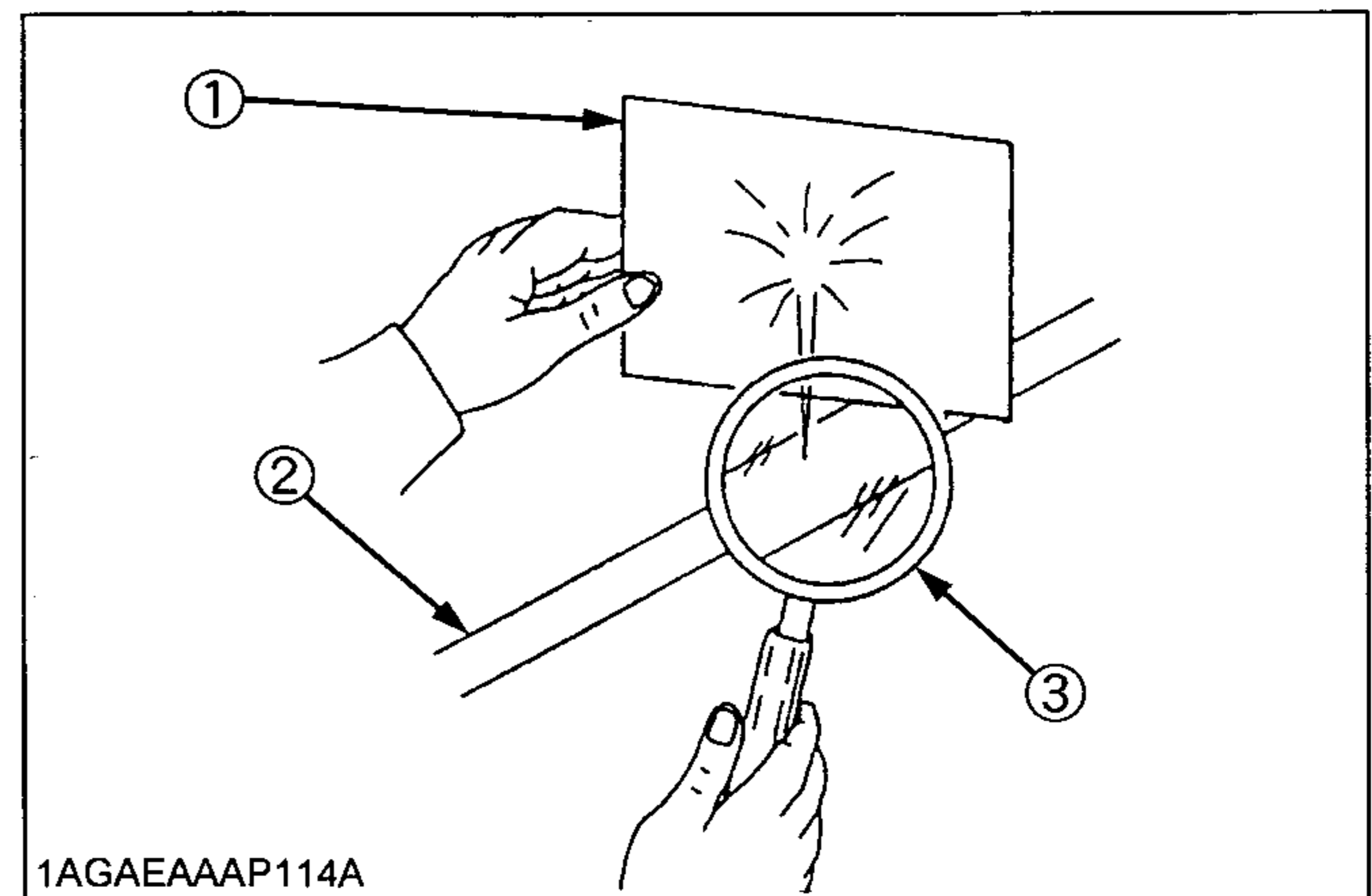

- (1) Cardboard
- (2) Hydraulic line
- (3) Magnifying glass

7. DANGER, WARNING AND CAUTION LABELS

(1) Part No. K2581-6557-1

	<p>WARNING TO AVOID PERSONAL INJURY OR DEATH FROM ROLL-OVER:</p>	<p>1. Kubota recommends the use of a Roll-Over Protective Structures (ROPS) and seat belt in almost all applications. 2. Remove the ROPS only when it substantially interferes</p>	<p>with operation or itself presents a safety risk. (Examples include work in orchards and vineyards.) ALWAYS REINSTALL IT BEFORE USING THE TRACTOR IN OTHER APPLICATIONS.</p>	<p>3. Never use just the seat belt or just the ROPS. They must be used together. For further details, consult your Operator's Manual or your local dealer.</p>
---	---	--	---	--

1AGAJAXAP041E

(2) Part No. K2581-6548-1

CAUTION

TO AVOID PERSONAL INJURY:

1. Read and understand the operator's manual before operation.
2. Before starting the engine, make sure that everyone is at a safe distance from the tractor and that the PTO is OFF.
3. Do not allow passengers on the tractor at any time.
4. Before allowing other people to use the tractor, have them read the operator's manual.
5. Check the tightness of all nuts and bolts regularly.
6. Keep all shields in place and stay away from all moving parts.
7. Slow down for turns, or rough roads.
8. On public roads use SMV emblem and hazard lights, if required by local traffic and safety regulations.
9. Pull only from the hitch.
10. Before dismounting lower the implement to the ground, set the parking brake, stop the engine and remove the key.
11. Securely support tractor and implements before working underneath.

1AGAJAXAP042E

(5) Part No. K2581-6549-1
Diesel fuel No fire only

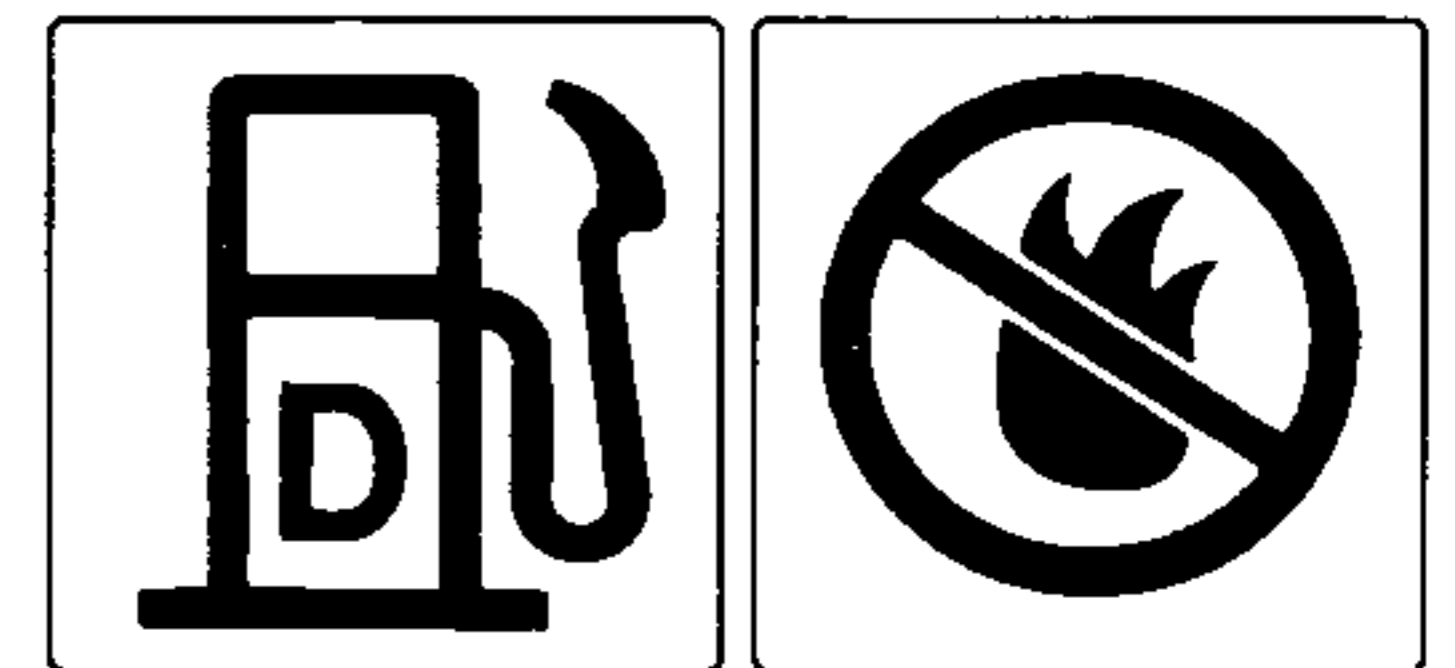

1AGAMAAAP2480

(3) Part No. 6C140-4746-1

WARNING

TO AVOID PERSONAL INJURY:

Do not modify or repair a ROPS because welding, grinding, drilling or cutting any portion may weaken the structure.

1AGAJAXAP045E

(4) Part No. K2581-6552-1

Do not put hands under the rear fender.

WARNING



TO AVOID PERSONAL INJURY: KEEP HANDS AWAY FROM PINCH POINTS OF LIFT ARMS.

1AGAJAXAP047E

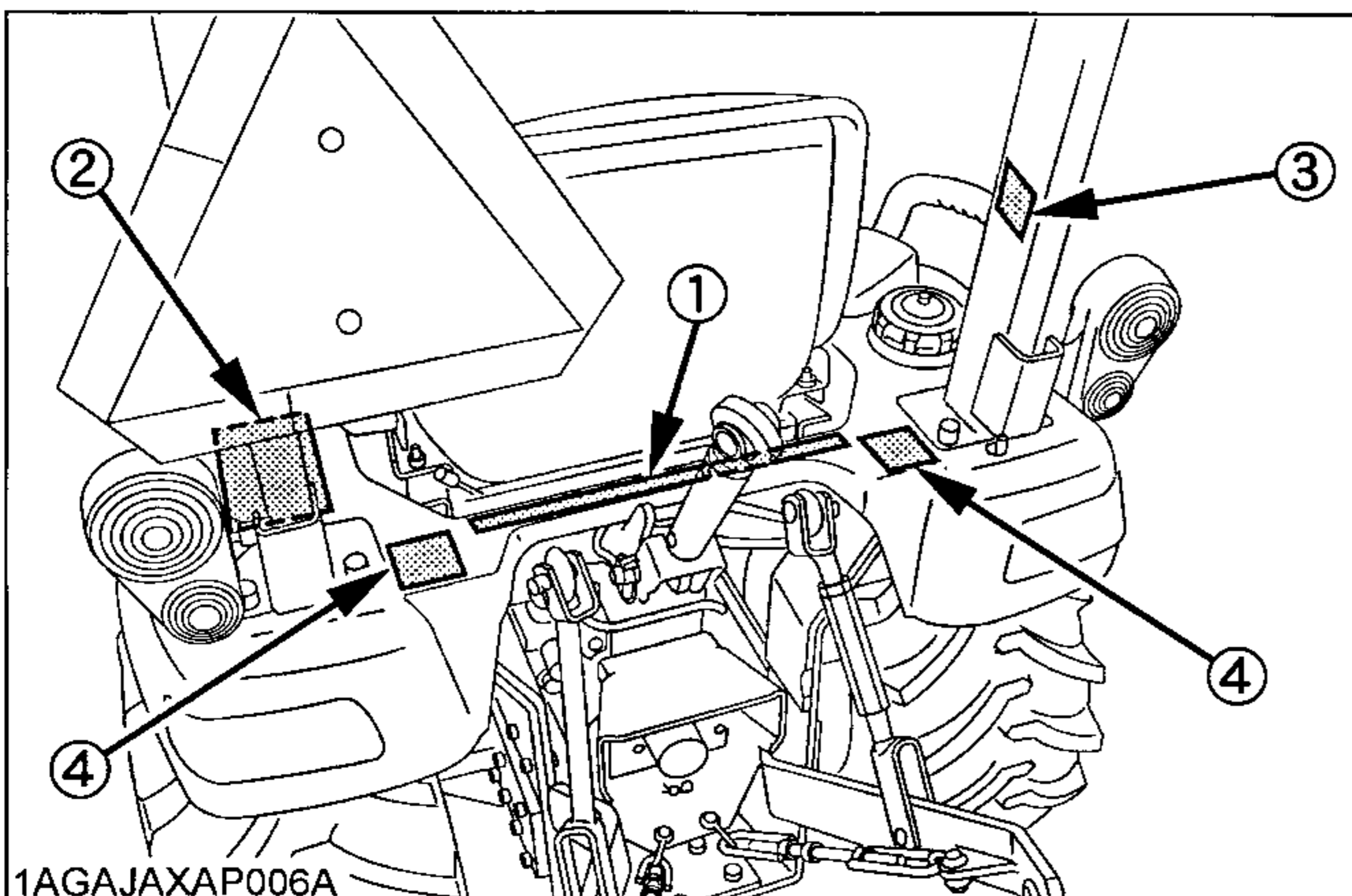

1AGAJAXAP006A

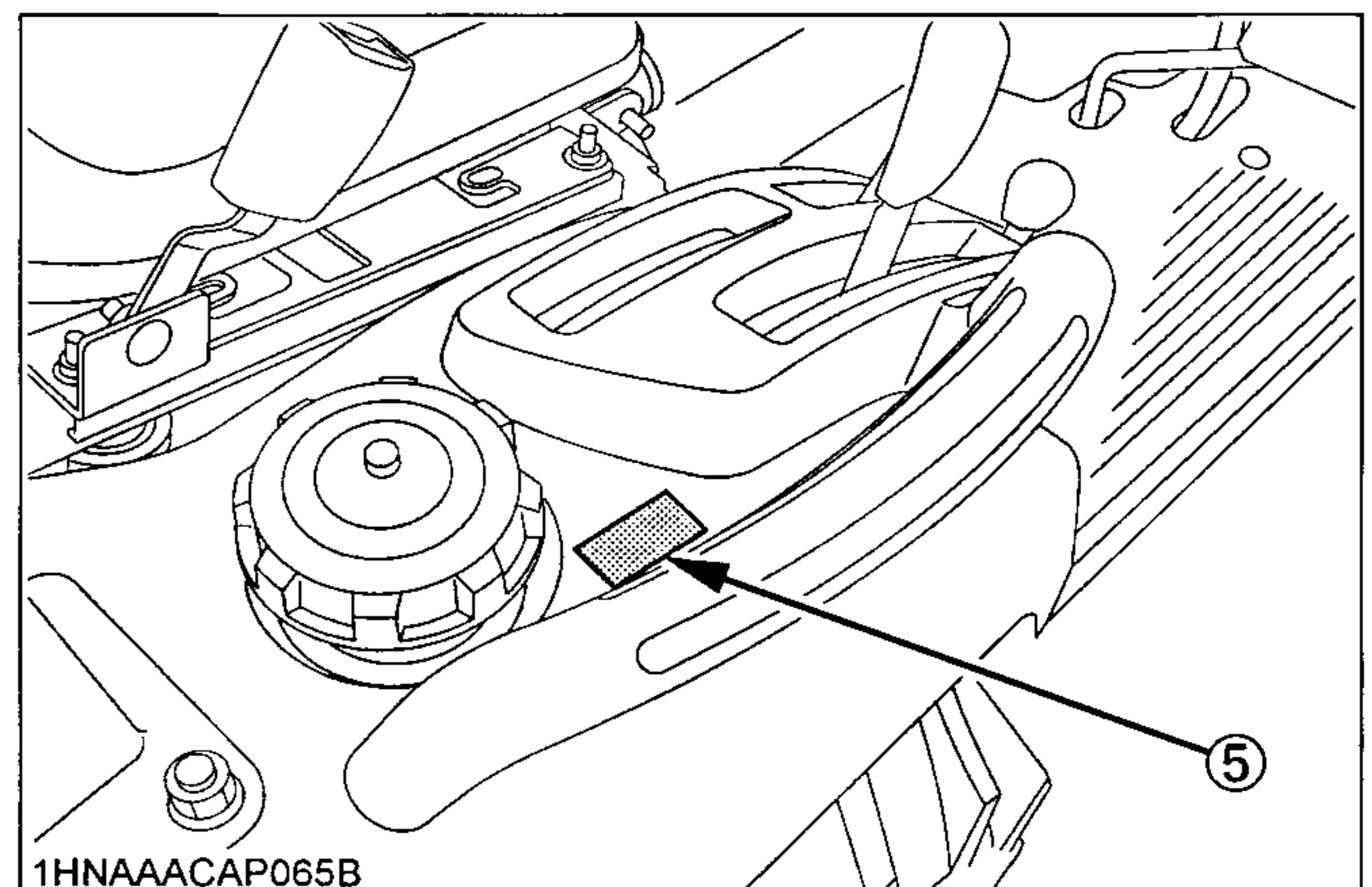

1HNAAACAP065B

(1) Part No. K2581-6554-1

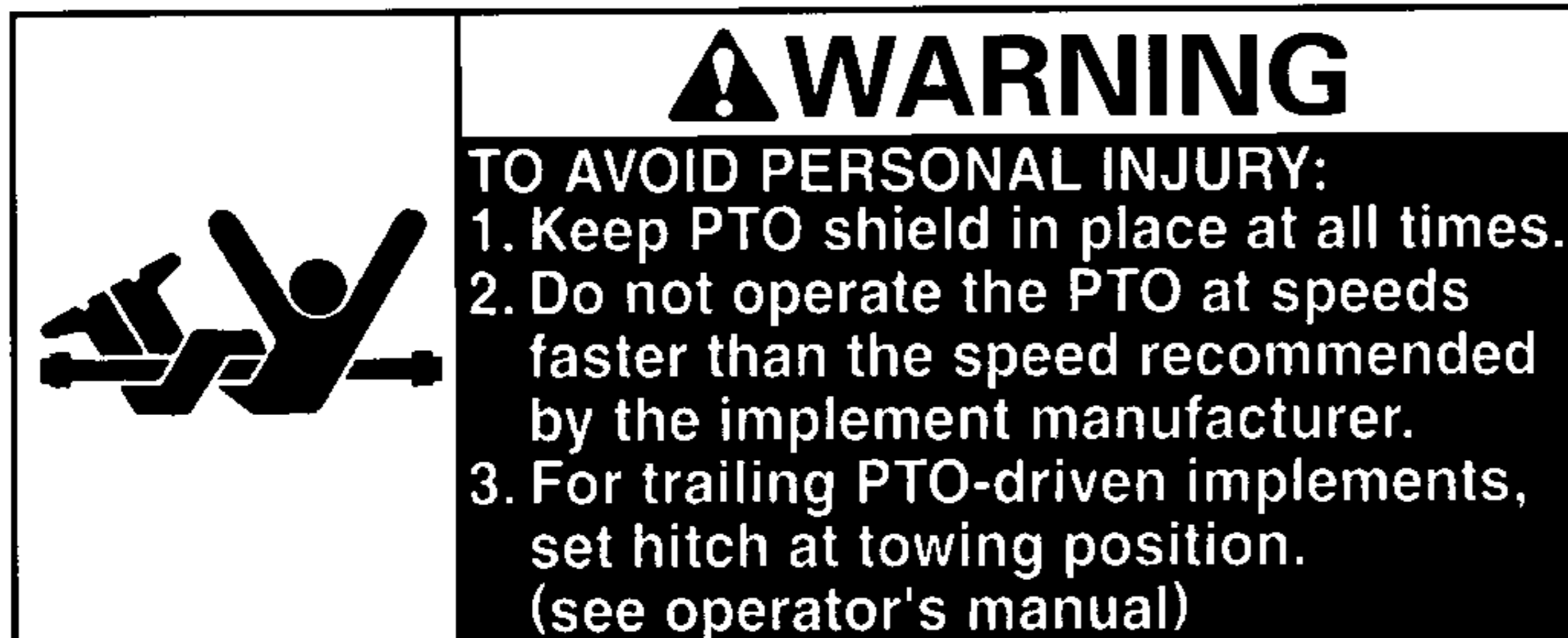

1AGAJAXAP044E

(2) Part No. K2581-6555-1



1AGAJAXAP043E

(3) Part No. K2561-6556-1



1AGAJAXAP046E

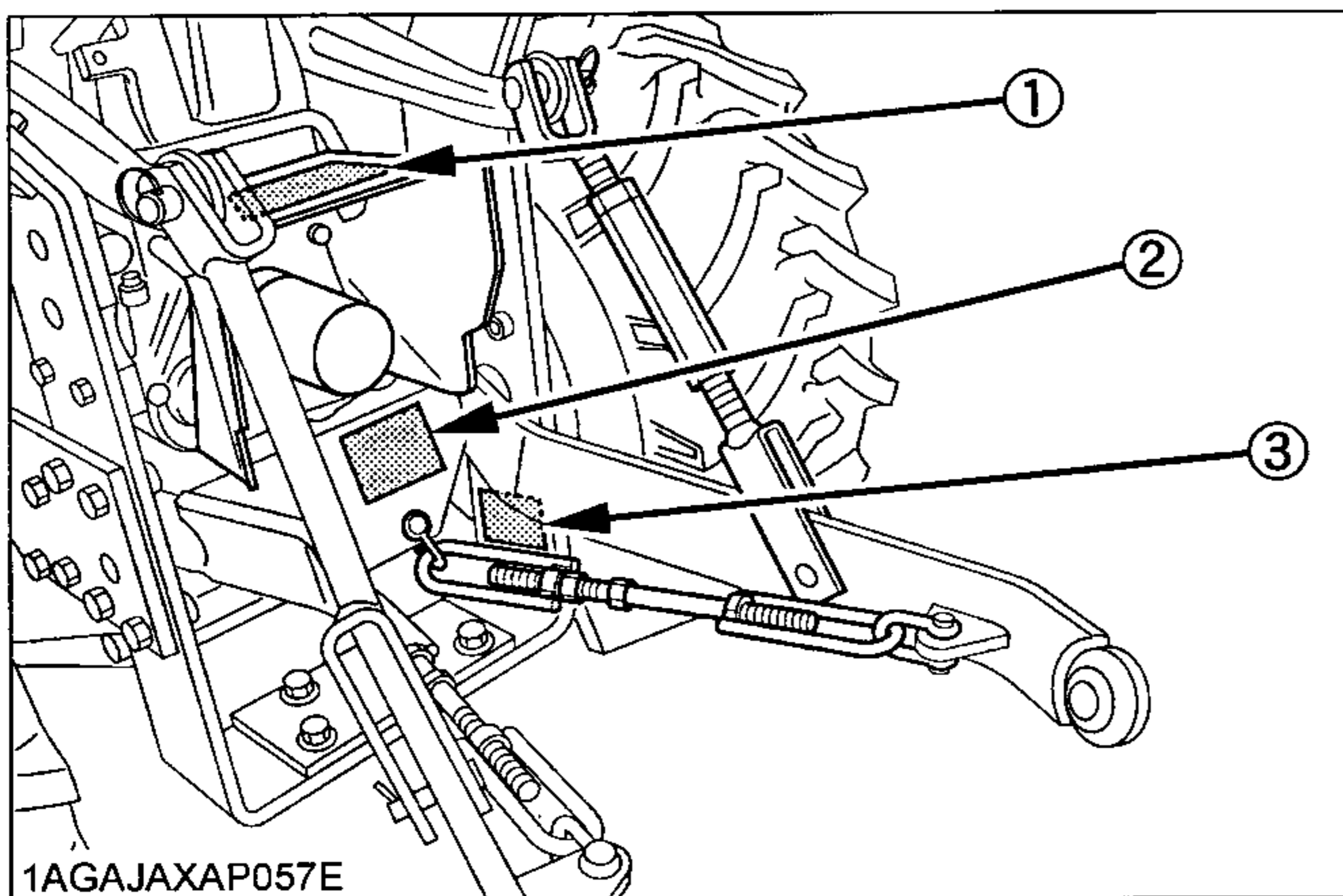

1AGAJAXAP057E

(1) Part No. K2581-6541-1



⚠ DANGER

TO AVOID POSSIBLE INJURY OR DEATH FROM A MACHINE RUNAWAY:

1. Do not start engine by shorting across starter terminals or bypassing the safety start switch. Machine may start in gear and move if normal starting circuitry is bypassed.
2. Start engine only from operator's seat with transmission and PTO off. Never start engine while standing on the ground.

1AGAJAXAP048E

(2) Part No. K2581-6547-1
Stay clear of engine fan and fanbelt.

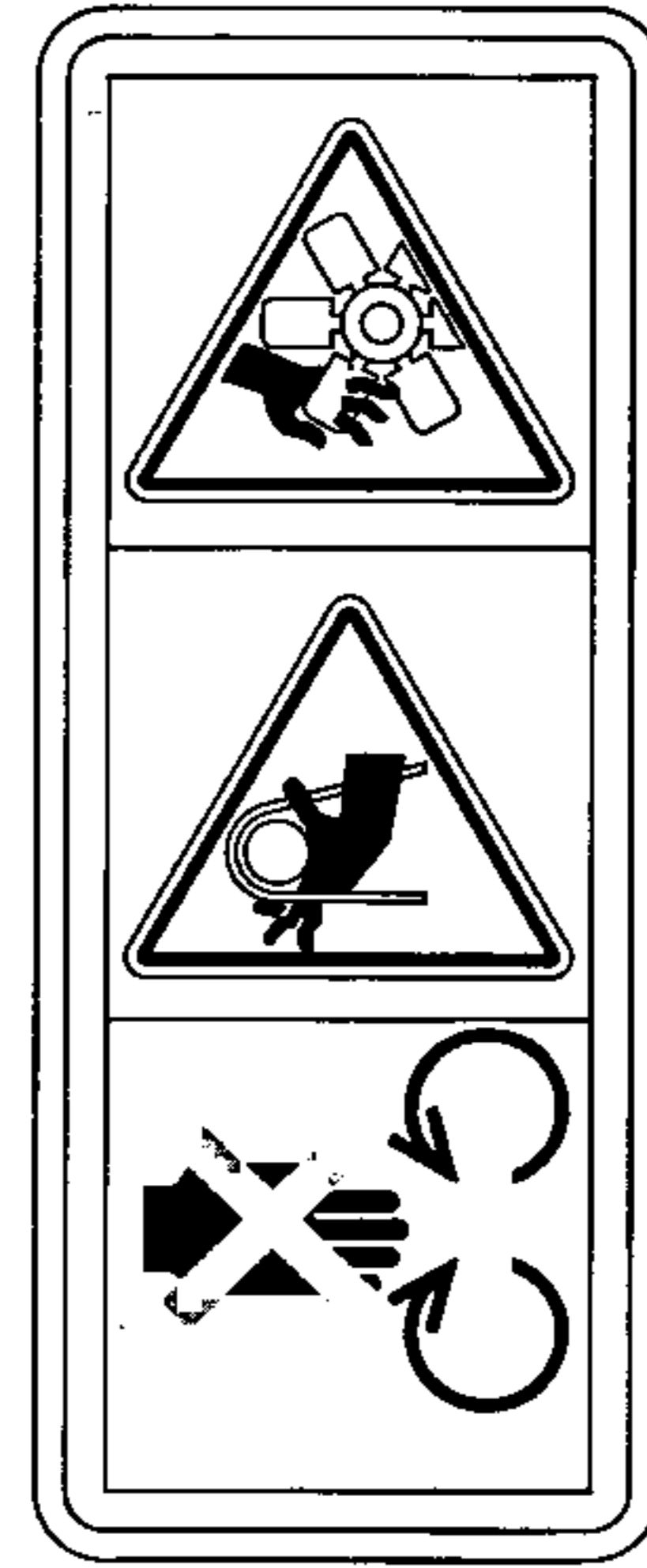

1AGAJAXAP049E

(3) Part No. K2581-6542-1
Do not touch hot surface like muffler, etc.

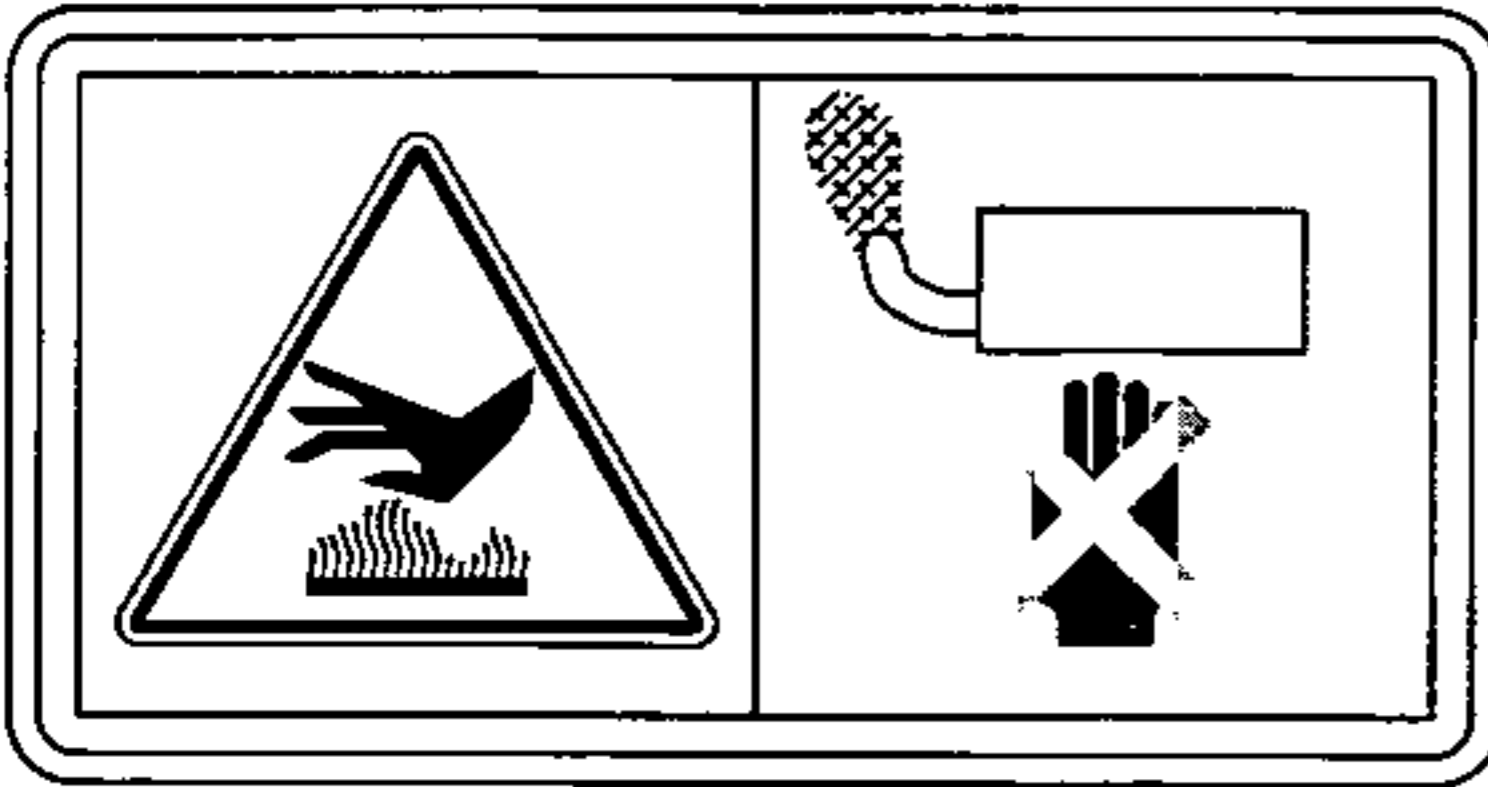

1AGAJAXAP050E

(4) Part No. K2581-6543-1

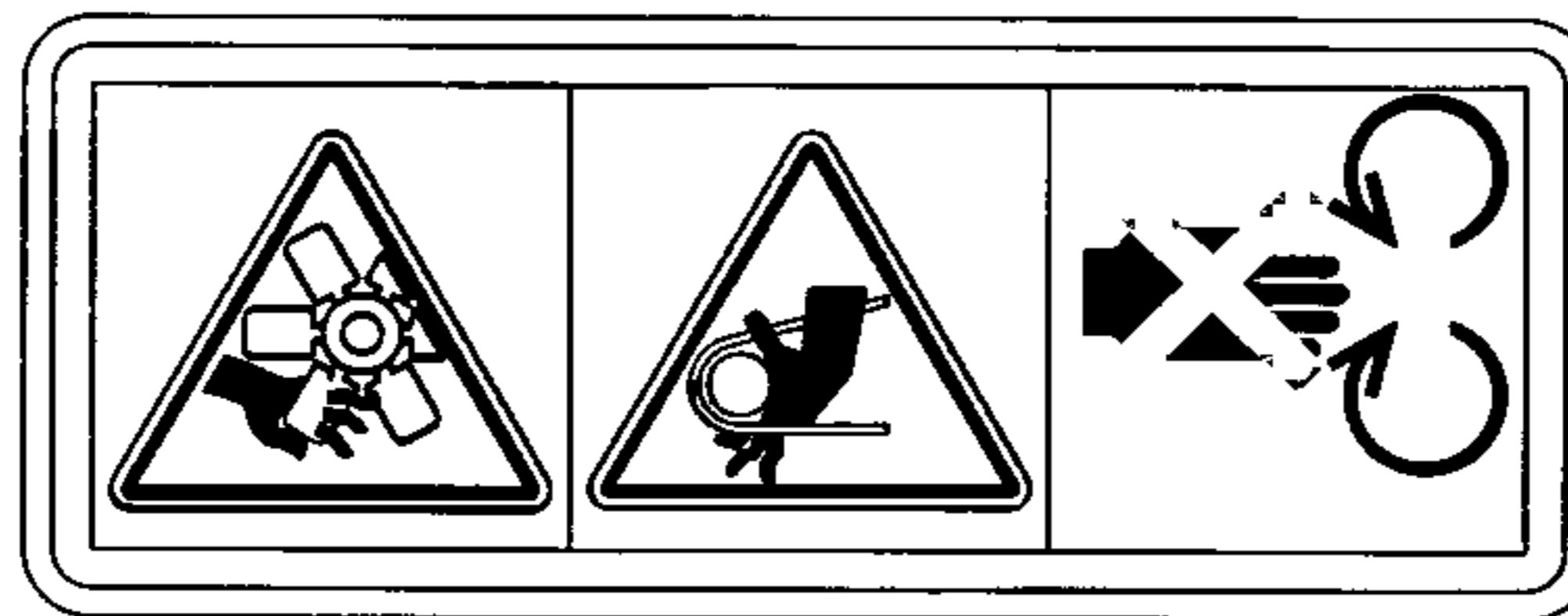

1AGAJAXAP052E

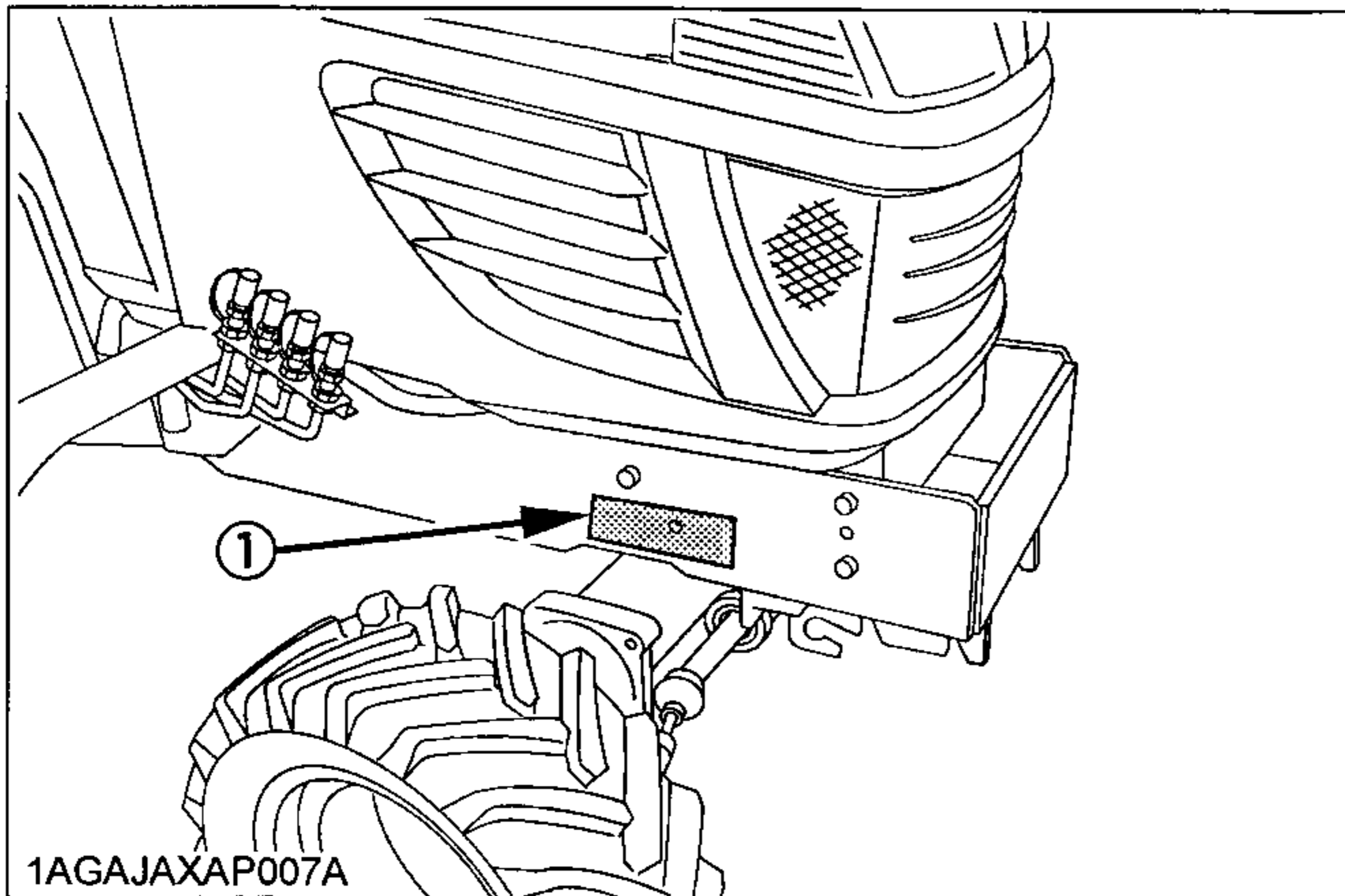

1AGAJAXAP007A

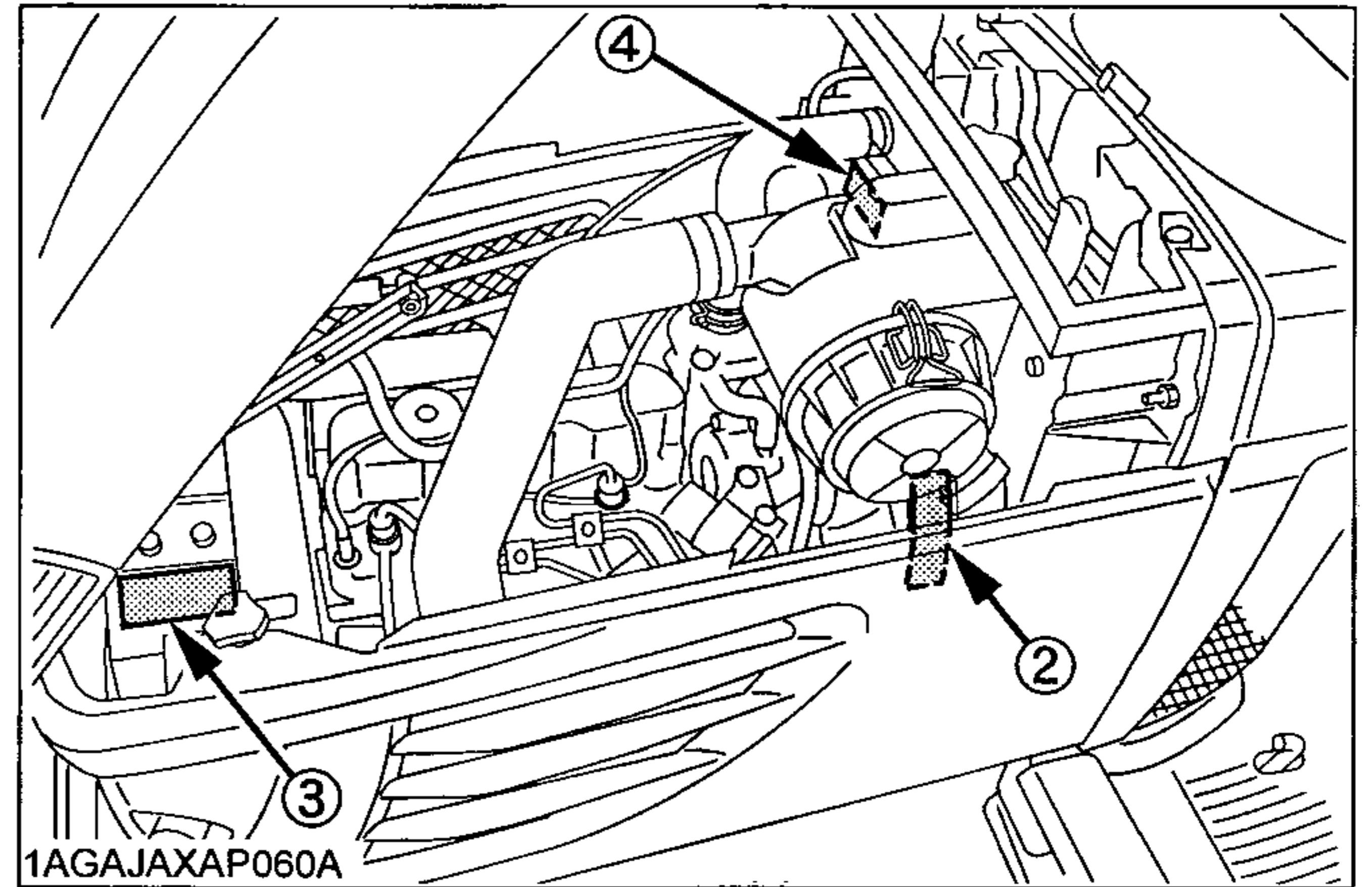

1AGAJAXAP060A

(1) Part No. K1211-6116-1

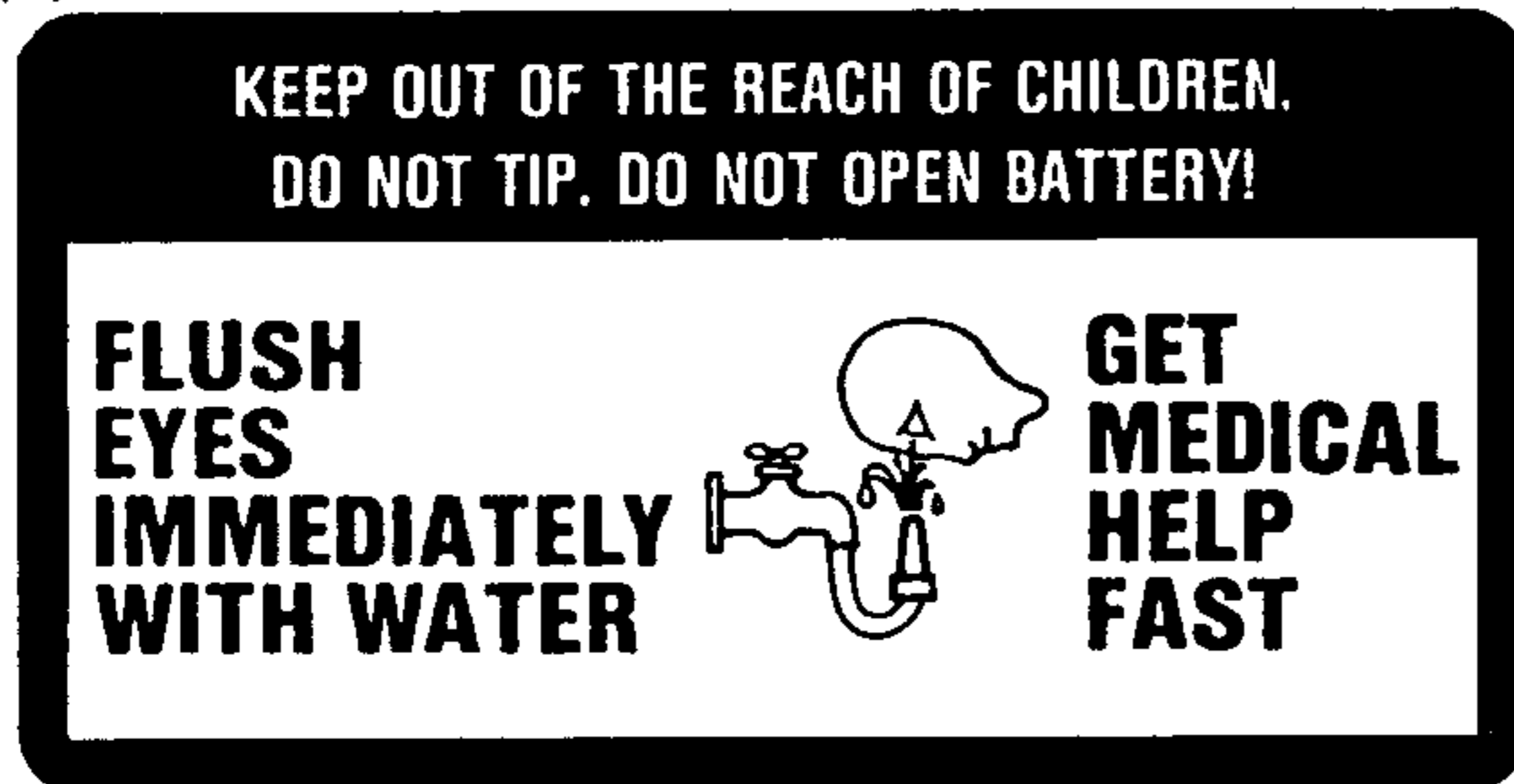

1AGAJAXAP053E

(2) Part No. K1211-6115-1



1AGAJAXAP054E

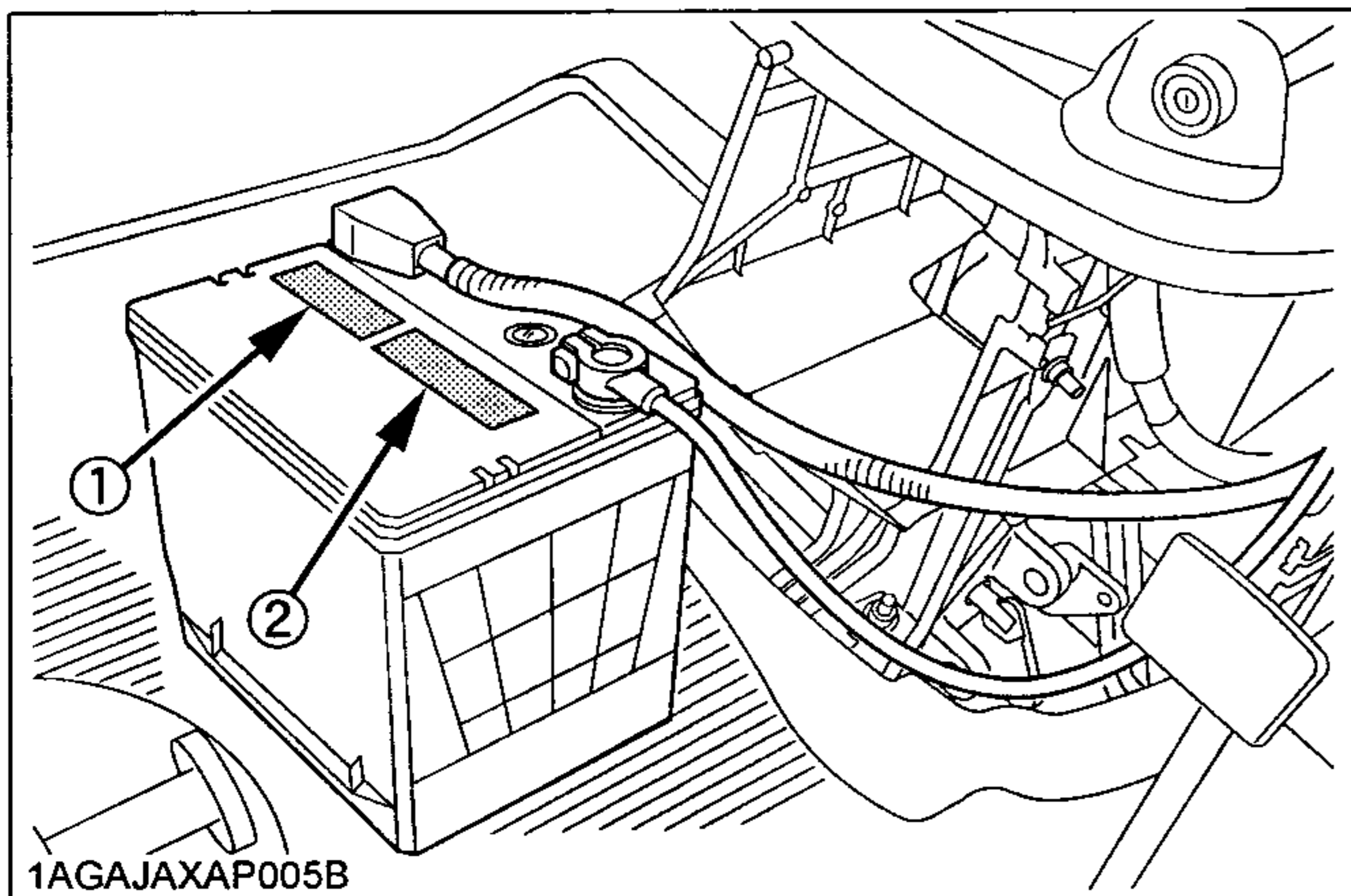

8. CARE OF DANGER, WARNING AND CAUTION LABELS

1. Keep danger, warning and caution labels clean and free from obstructing material.
2. Clean danger, warning and caution labels with soap and water, dry with a soft cloth.
3. Replace damaged or missing danger, warning and caution labels with new labels from your local KUBOTA Dealer.
4. If a component with danger, warning and caution label(s) affixed is replaced with new part, make sure new label(s) is (are) attached in the same location(s) as the replaced component.
5. Mount new danger, warning and caution labels by applying on a clean dry surface and pressing any bubbles to outside edge.

SERVICING OF TRACTOR

Your dealer is interested in your new tractor and has the desire to help you get the most value from it. After reading this manual thoroughly, you will find that you can do some of the regular maintenance yourself.

However, when in need of parts or major service, be sure to see your KUBOTA Dealer.

For service, contact the KUBOTA Dealership from which you purchased your tractor or your local KUBOTA Dealer. When in need of parts, be prepared to give your dealer both the tractor and engine serial numbers.

Locate the serial numbers now and record them in the space provided.

	Type	Serial No.
Tractor	BX2350RV	60964
Engine	D902E2-BX2	651650
Date of Purchase	6-12-2007	Delivery
Name of Dealer	Haydon Equip. Inc.	
(To be filled in by purchaser)		

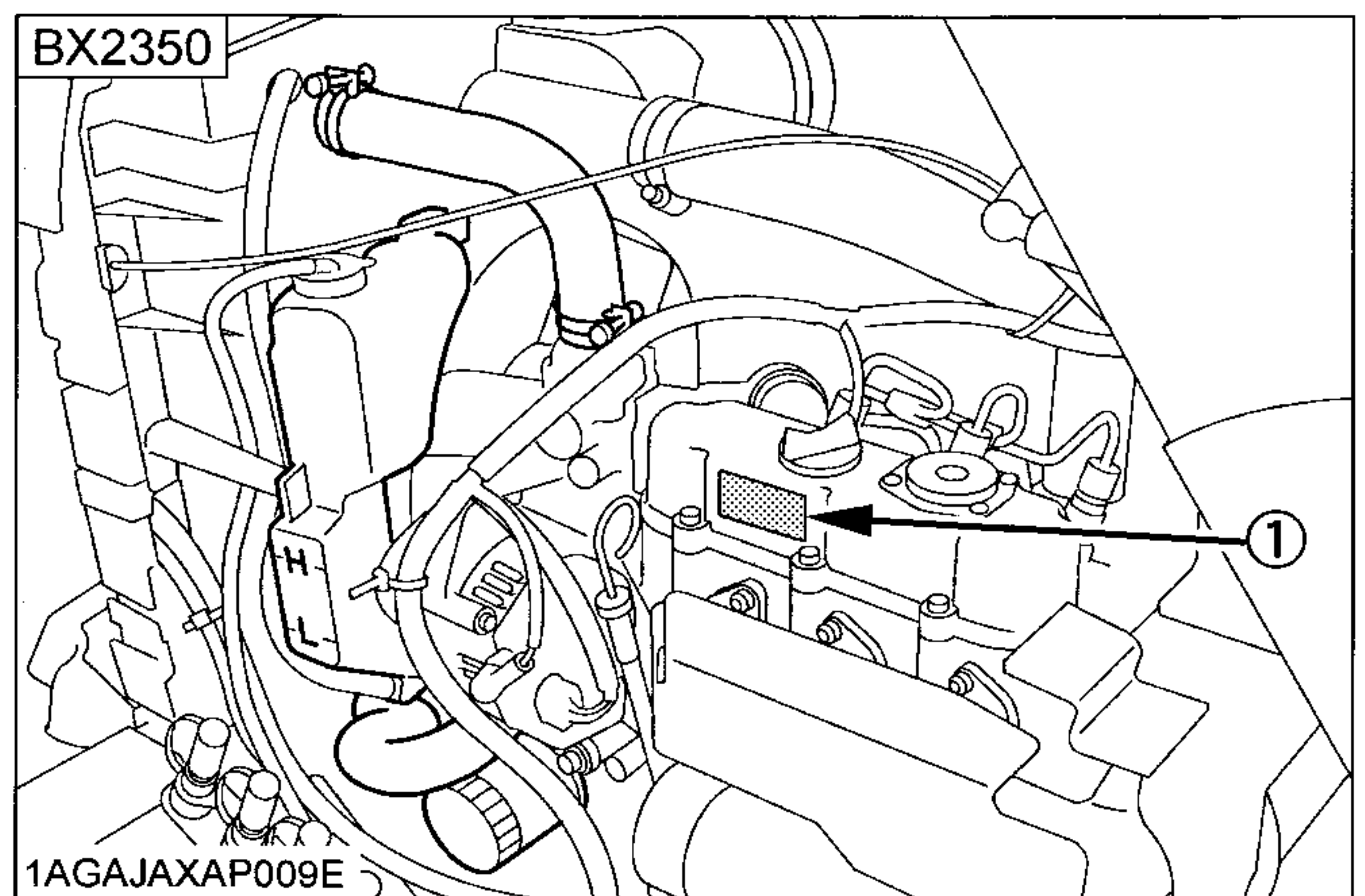
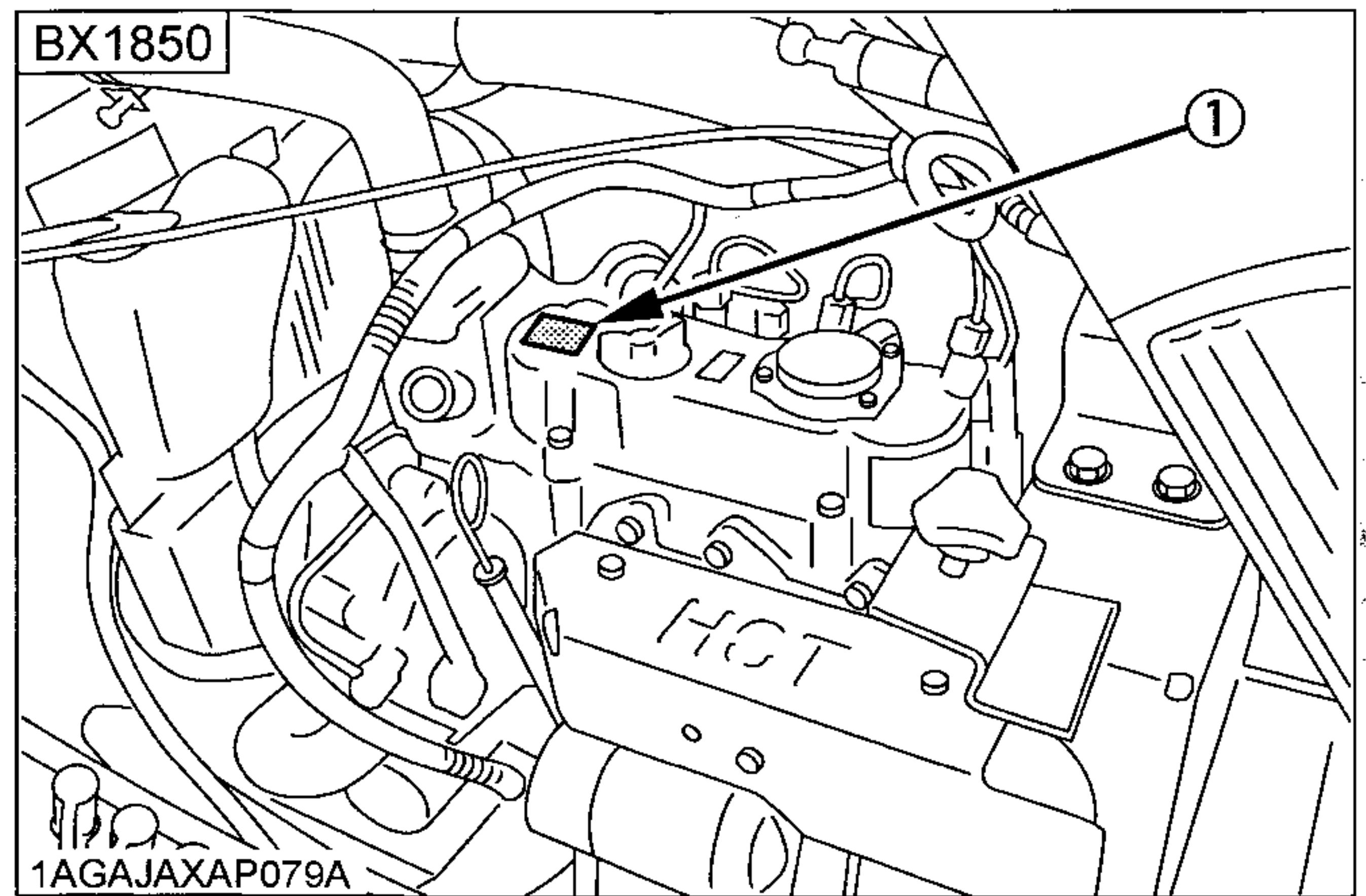

(1) Engine serial number

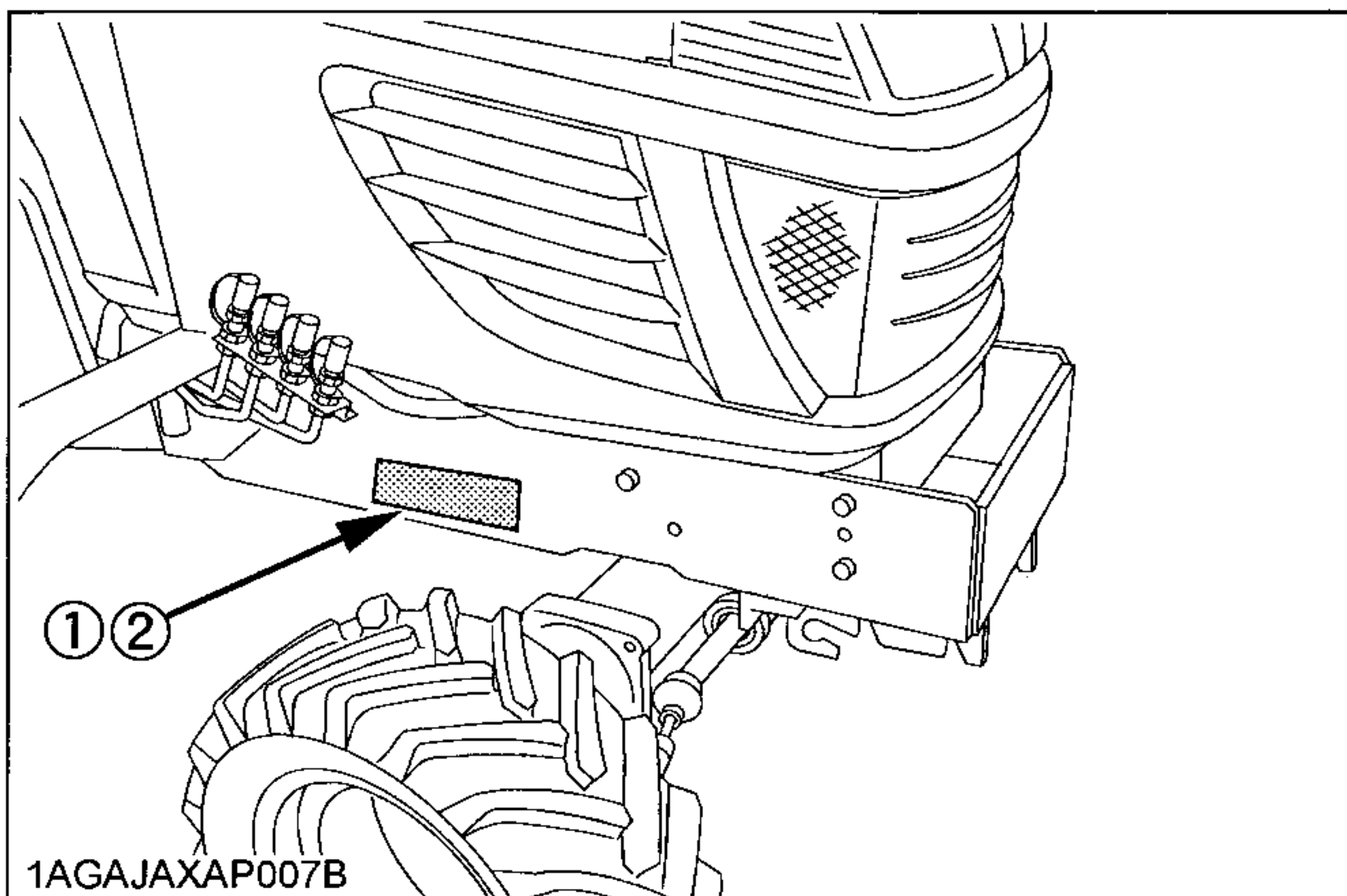

(1) Tractor identification plate
(2) Tractor serial number

SPECIFICATIONS

SPECIFICATION TABLE

Model			BX1850	BX2350			
PTO power		kW (HP)	10.2 (13.7)*	13.2 (17.7)*			
Engine	Maker		KUBOTA				
	Model		D722-E2-BX-2	D902-E2-BX-2			
	Type		Indirect injection, vertical, water-cooled, 4-cycle diesel				
	Number of cylinders		3				
	Bore and stroke		mm (in.)	67x68 (2.64x2.68)	72x73.6 (2.83x2.90)		
	Total displacement		cm ³ (cu. in.)	719 (43.9)	898 (54.8)		
	Engine gross power		kW (HP)	13.4 (18.0)	17.1 (23.0)		
	Rated revolution		rpm	3200			
	Maximum torque		N-m (ft-lbs.)	44.9 (33.1)	56.1 (41.4)		
	Battery			12V, RC: 62min, CCA:435A	12V, RC:80min, CCA:535A		
	Fuel			Diesel fuel No.2 [above -10 °C (14 °F)] Diesel fuel No.1 [below -10 °C (14 °F)]			
Capacities	Fuel tank		L (U.S.gals.)		25 (6.6)		
	Engine crankcase (with filter)		L (U.S.qts.)		2.9 (3.06)	3.1 (3.3)	
	Engine coolant		L (U.S.qts.)		2.5 (2.6)	2.7 (2.8)	
	Recovery tank		L (U.S.qts.)		0.4 (0.4)		
	Transmission case		L (U.S.gals.)		11.6 (3.1)		
Dimensions	Overall length (without 3p)		mm (in.)		2035 (80.1)	2120 (83.5)	
	Overall length (with 3p)		mm (in.)		2340 (92.1)	2425 (95.5)	
	Overall width (min. tread)		mm (in.)		1145 (45.1)		
	Overall height	(with ROPS)		mm (in.)		1760 (69.3)	1785 (70.3)
				mm (in.)		1230 (48.4) (Top of seat)	1255 (49.4) (Top of seat)
	Wheel base		mm (in.)		1340 (52.8)	1400 (55.1)	
	Min. ground clearance		mm (in.)		150 (5.9)	175 (6.9)	
	Tread	Front		mm (in.)		880 (34.6)	910 (35.8)
Rear		mm (in.)		820 (32.2)			
Weight (with ROPS)		kg (lbs.)		570 (1256.6)	585 (1289.7)		
Clutch			N / A				
Traveling system	Tire	Front	16x7.50-8		18x8.50-10		
		Rear	24x12.00-12		26x12.00-12		
	Steering		Hydrostatic type power steering				
	Transmission		Main: Hydrostatic transmission, High-Low gear shift (2 forward, 2 reverse)				
	Brake		Wet disk type				
Min. turning radius		m (feet)		2.18 (7.15)	2.3 (7.5)		
Hydraulic unit	Hydraulic control system		Directional control, auto-return lever system				
	Pump capacity		L/min: (gals/min.)		23.5 (6.2)		
	Three point hitch		SAE Category 1				
	Max. lift force	At lift points		N (lbs.)		5390 (1210)**	
24in. behind lift points		N (lbs.)		3040 (680)**			
PTO	Rear PTO	SAE 1-3/8, 6 splines					
		Revolution		rpm	1 speed (540 rpm at 3142 engine rpm)		
	MID-PTO	USA No.5 (KUBOTA 10-tooth) involute spline					
Revolution		rpm	1 speed (2500 rpm at 3043 engine rpm)				

NOTE : * Manufacturer's estimate The company reserve the right to change the specifications without notice.
 **See and check IMPLEMENT LIMITATIONS.

TRAVELING SPEEDS

(At rated engine rpm)

Model		BX1850		BX2350	
Tire size (Rear)		24 x 12.00 - 12		26 x 12.00 - 12	
	Range gear shift lever	km / h	mph	km / h	mph
Forward	Low	0 to 5.5	0 to 3.4	0 to 6.0	0 to 3.7
	High	0 to 12.0	0 to 7.5	0 to 13.0	0 to 8.1
Reverse	Low	0 to 4.0	0 to 2.5	0 to 4.5	0 to 2.8
	High	0 to 9.0	0 to 5.6	0 to 10.0	0 to 6.2

The company reserves the right to change the specification without notice.

IMPLEMENT LIMITATIONS

The KUBOTA Tractor has been thoroughly tested for proper performance with implements sold or approved by KUBOTA. Use with implements which are not sold or approved by KUBOTA and which exceed the maximum specifications listed below, or which are otherwise unfit for use with the KUBOTA Tractor may result in malfunctions or failures of the tractor, damage to other property and injury to the operator or others. [Any malfunctions or failures of the tractor resulting from use with improper implements are not covered by the warranty.]

	Tread (max.width)		Lower link end max. loading weight W_0
	Front	Rear	
BX1850	880 mm (34.6 in.)	820 mm (32.2 in.)	550 kg (1210 lbs.)
BX2350	910 mm (35.8 in.)		

Actual figures			
	Implement weight W_1 and / or size	Max. Hitch Load W_2	Trailer loading weight W_3 Max. capacity
BX1850	As in the following list (Shown on the next page)	250 kg (550 lbs.)	800 kg (1765 lbs.)
BX2350			

Lower link end max. loading weight.....The max. allowable load which can be put on the lower link end : W_0
 Implement weight.....The implement's weight which can be put on the lower link : W_1
 Max. hitch load..... W_2
 Trailer loading weightThe max. loading weight for trailer (without trailer's weight) : W_3

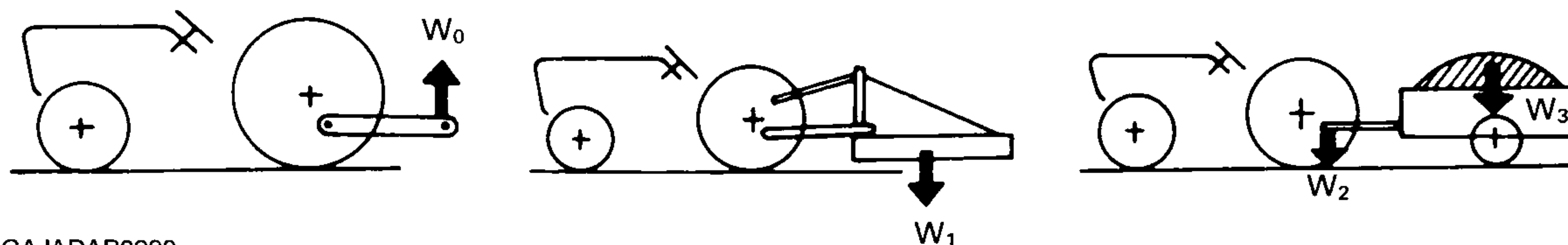

1AGAJADAP0290

NOTE :

- Implement size may vary depending on soil operating conditions.

Implement		Remarks	BX1850	BX2350
Mower	Mid-mount	Max. cutting width cm(in.)	137 (54)	152 (60)
		Max. weight kg(lbs.)	95 (210)	140 (309)
	Rotary-Cutter (1 Blade)	Max. cutting width cm(in.)	107 (42)	107 (42)
		Max. weight kg(lbs.)	140 (300)	140 (300)
	Rear-mount (2 or 3 Blade)	Max. cutting width cm(in.)	122 (48)	152 (60)
		Max. weight kg(lbs.)	115 (250)	140 (300)
Flail-mower	Max. cutting width cm(in.)	107 (42)	107 (42)	
Sickle bar	Max. cutting width cm(in.)	122 (48)	122 (48)	
Rotary tiller		Max. tilling width cm(in.)	107 (42)	107 (42)
		Max. weight kg(lbs.)	170 (375)	170 (375)
Bottom plow		Max. size in.	12 x 1	14 x 1
Disc plow		Max. size in.	22 x 1	22 x 1
Cultivator		Max. size cm(in.)	122 (48) 1 Row	122 (48) 1 Row
Disc harrow		Max. harrowing width cm(in.)	122 (48)	137 (54)
		Max. weight kg(lbs.)	120 (265)	140 (300)
Sprayer		Max. tank capacity L(U.S.gals.)	150 (40)	150 (40)
Front blade		Max. cutting width cm(in.)	137 (54)	152 (60)
		Sub frame	Necessary	Necessary
Rear blade		Max. cutting width cm(in.)	137 (54)	152 (60)
		Max. weight kg(lbs.)	140 (300)	160 (350)
Front loader		Max. lifting capacity kg(lbs.)	200 (440)	240 (530)
		Max. width cm(in.)	122 (48)	122 (48)
Box blade		Max. cutting width cm(in.)	122 (48)	122 (48)
		Max. weight kg(lbs.)	170 (375)	170 (375)
Snow blower (Front)		Max. working width cm(in.)	127 (50)	127 (50)
		Max. weight kg(lbs.)	160 (350)	160 (350)
		Sub frame	Necessary	Necessary
Post hole digger		Digging depth cm(in.)	114 (45)	114 (45)
Rotary broom		Cleaning width cm(in.)	119 (47)	119 (47)
Trailer		Max. load capacity kg(lbs.)	800 (1765)*	800 (1765)*

NOTE :

- Backhoes cannot be attached.
- Implement size may vary depending on soil operating conditions.
- * Reduce speed and trailer loads when operating in slippery conditions or when operating on slopes and utilize front wheel drive.

INSTRUMENT PANEL AND CONTROLS

■ Instrument Panel, Switches and Hand Controls

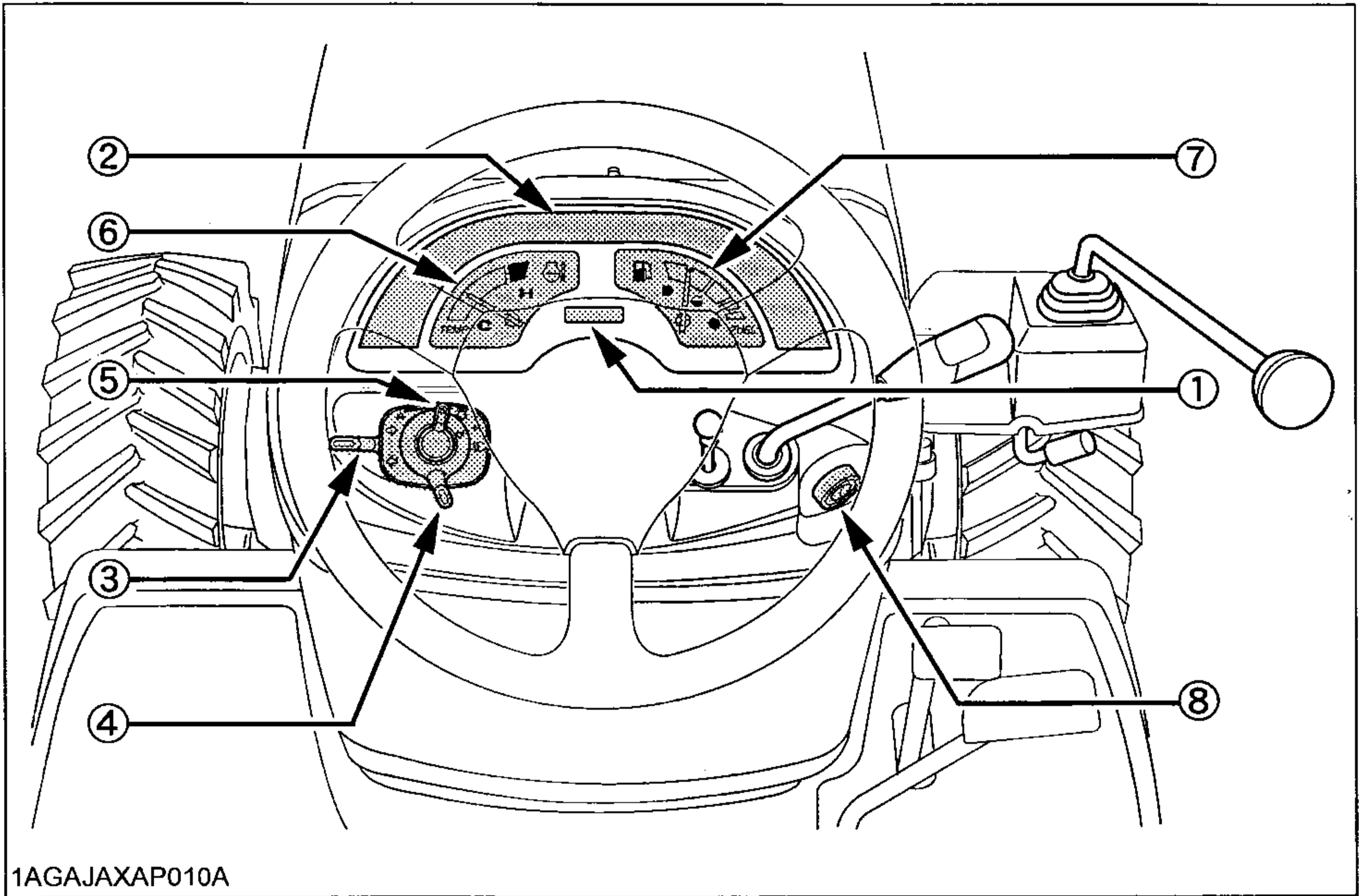

ILLUSTRATED CONTENTS

(1) Hourmeter / Tachometer.....	19
(2) Easy Checker(TM).....	9,18
(3) Turn signal light switch.....	14
(4) Head light switch.....	14
(5) Hazard light switch.....	14
(6) Coolant temperature gauge.....	18
(7) Fuel gauge.....	18
(8) Key switch.....	9

■ Foot and Hand Controls

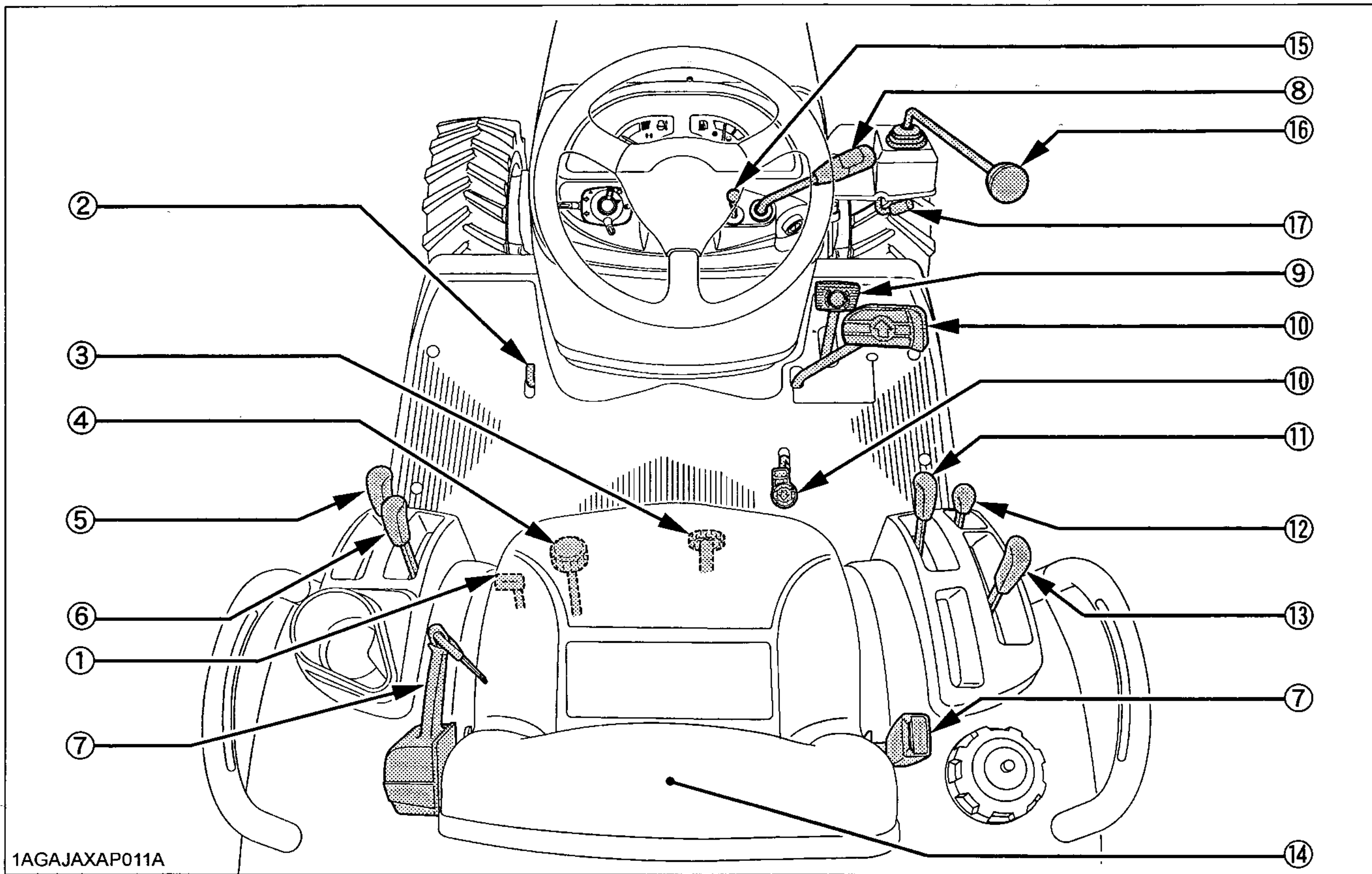

1AGAJAXAP011A

ILLUSTRATED CONTENTS

(1) Differential lock pedal.....	20
(2) Parking brake lock pedal.....	9,14,16,19
(3) 3-Point hitch lowering speed knob.....	27
(4) Cutting height control dial.....	28
(5) PTO select lever.....	22
(6) PTO clutch lever.....	9,23
(7) Seat belt.....	14
(8) Hand throttle lever.....	9,16
(9) Brake pedal.....	9,14,16,19
(10) Speed control pedal.....	9,16
(11) Hydraulic control lever.....	9,27,28
(12) Front wheel drive lever.....	15
(13) Range gear shift lever (Hi-Lo).....	9,15
(14) Operator's seat.....	13
(15) Speed set rod (BX2350).....	17
(16) Auxiliary hydraulic control lever (if equipped).....	30
(17) Lock lever (if equipped).....	9,30

PRE-OPERATION CHECK

DAILY CHECK

To prevent trouble from occurring, it is important to know the condition of the tractor well. Check it before starting.



CAUTION

To avoid personal injury:

- Be sure to check and service the tractor on a level surface with the engine shut off and the parking brake "ON" and implement lowered to the ground.

Check item

- Walk around inspection
- Check engine oil level
- Check transmission oil level
- Check coolant level
- Clean grill and radiator screen
- Check air cleaner evacuator valve
(When used in a dusty place)
- Check brake pedal
- Check indicators, gauges and meter
- Check lights
- Check wire harness
- Check seat belt and ROPS
- Refuel
(See "DAILY CHECK" in Periodic Service section)
- Care of danger, warning and caution labels
(See "DANGER, WARNING AND CAUTION LABELS"
in Safe Operation section)

OPERATING THE ENGINE

CAUTION

To avoid personal injury:

- Read "Safe Operation" in the front of this manual.
- Read the danger, warning and caution labels located on the tractor.
- To avoid the danger of exhaust fume poisoning, do not operate the engine in a closed building without proper ventilation.
- Never start engine while standing on ground. Start engine only from operator's seat.
- Make it a rule to set all shift levers to "NEUTRAL" positions and to place PTO lever in "OFF" position before starting the engine.

IMPORTANT :

- Do not use starting fluid or ether.
- To protect the battery and the starter, make sure that the starter is not continuously turned for more than 30 seconds.

STARTING THE ENGINE

1. Make sure the parking brake is set.

1. To set the parking brake;
 - (1) Depress the brake pedal.
 - (2) Latch the brake pedal on pushing and holding the parking brake lock pedal then releasing pressure on the brake pedal.
2. To release the parking brake, depress the brake pedal again.

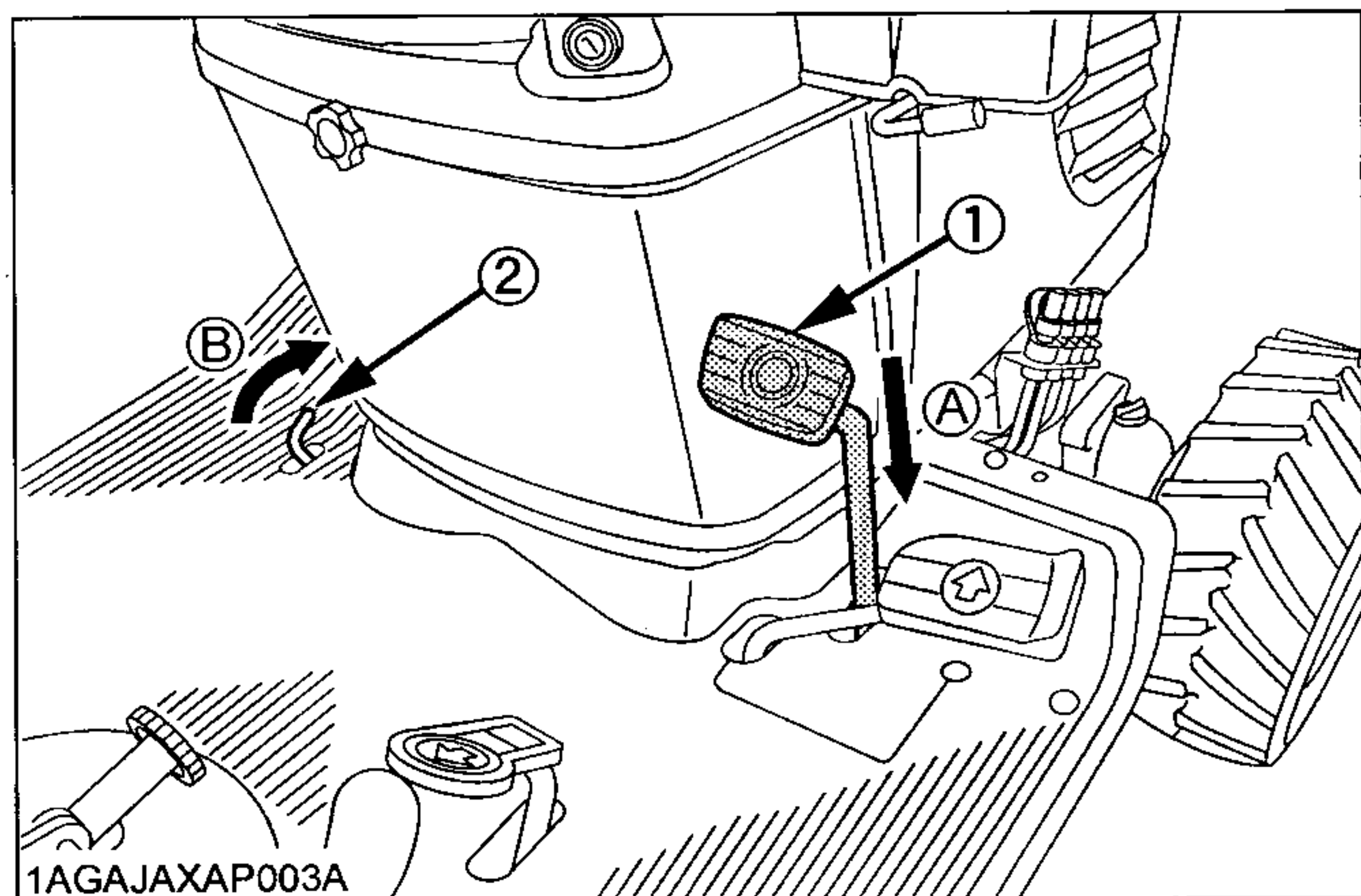

(1) Brake pedal (A) "DEPRESS"
 (2) Parking brake lock pedal (B) "PUSH FORWARD WHILE DEPRESSING (1)"

NOTE :

- It is recommended that the operator practice engaging and disengaging the parking brake on a flat surface without the engine running before operating the tractor for the first time.





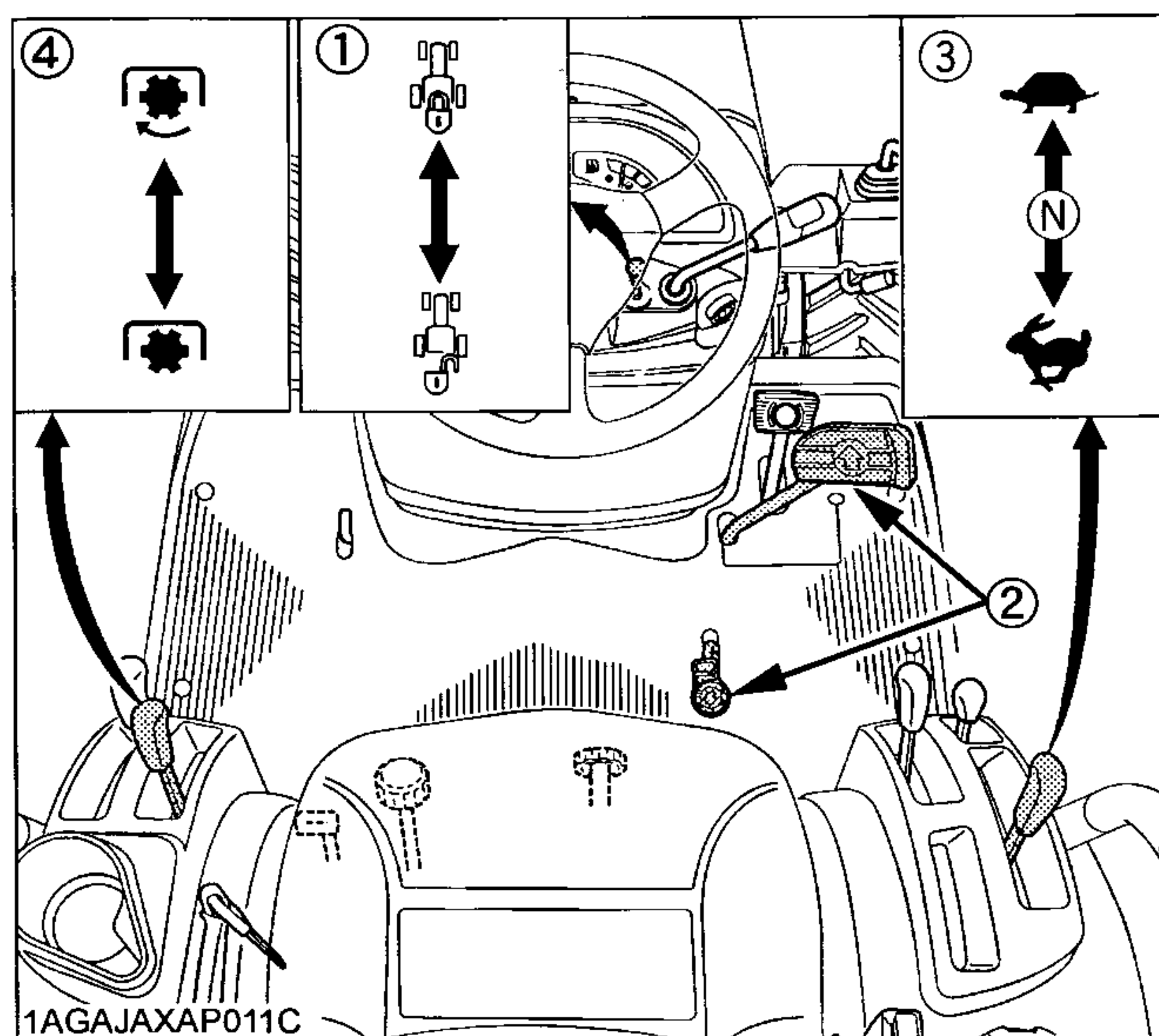

2. Place the PTO clutch lever in "OFF" position.

3. Place the speed set rod in "OFF" position.(BX2350)

Place the speed control pedal in "NEUTRAL" position.

Place the range gear shift lever (Hi-Lo) in "NEUTRAL" position.



- | | |
|------------------------------------|---|
| (1) Speed set rod (BX2350 only) |  "ON" |
| |  "OFF" |
| (2) Speed control pedal |  "Hi" |
| (3) Range gear shift lever (Hi-Lo) | (N) "NEUTRAL" |
| |  "Lo" |
| (4) PTO clutch lever |  "ON" |
| |  "OFF" |

NOTE :

- The speed control pedal automatically returns to "NEUTRAL" when the operator's foot is released from the pedal.

4. Lock the auxiliary hydraulic control lever in "NEUTRAL" position. (if equipped)

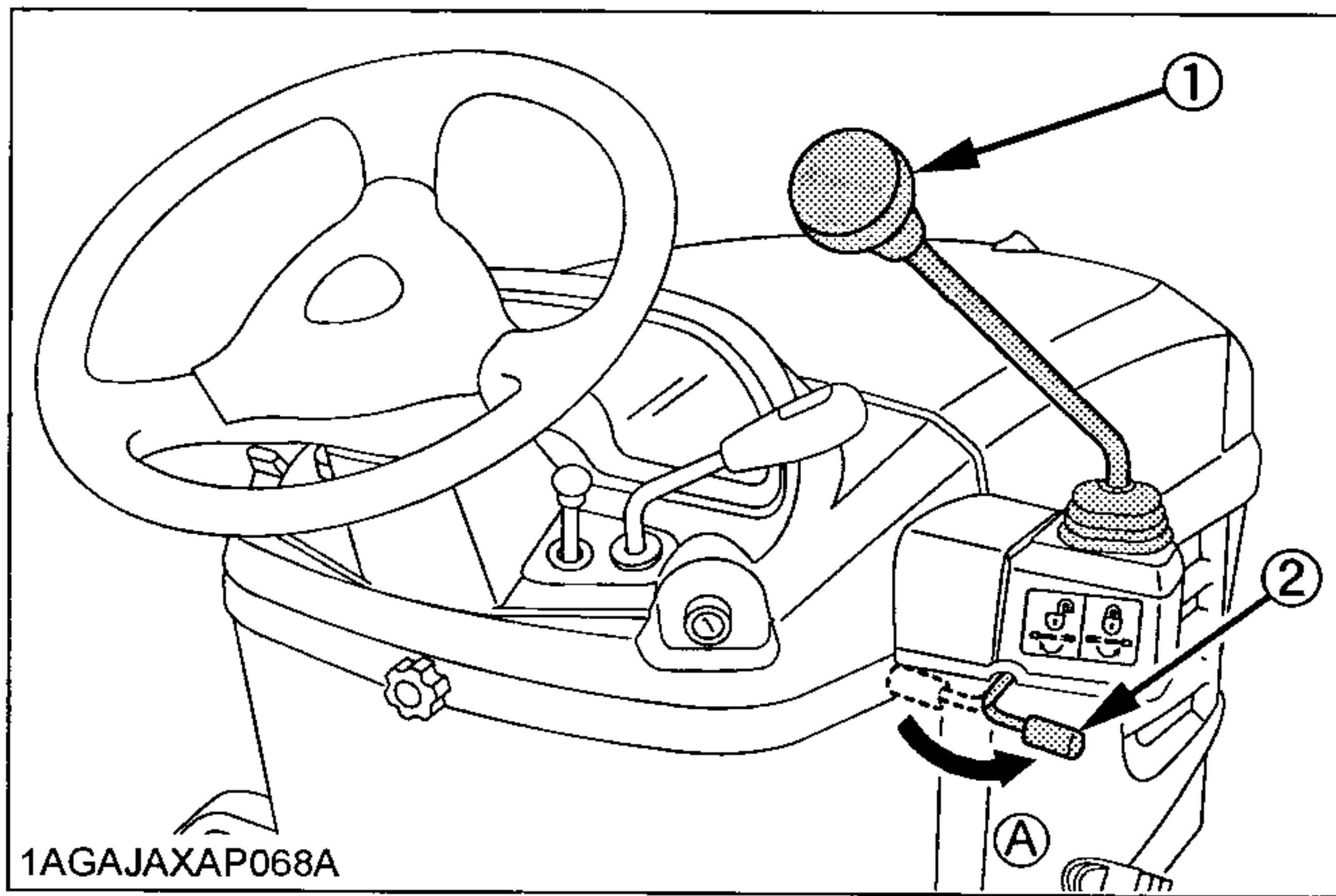

(1) Auxiliary hydraulic control lever (A) "LOCK"
(2) Lock lever

5. Move the hydraulic control lever forward. (With the implement in place.)

To lower implement, move the hydraulic control lever forward.
Check that implement is down at lowest position.

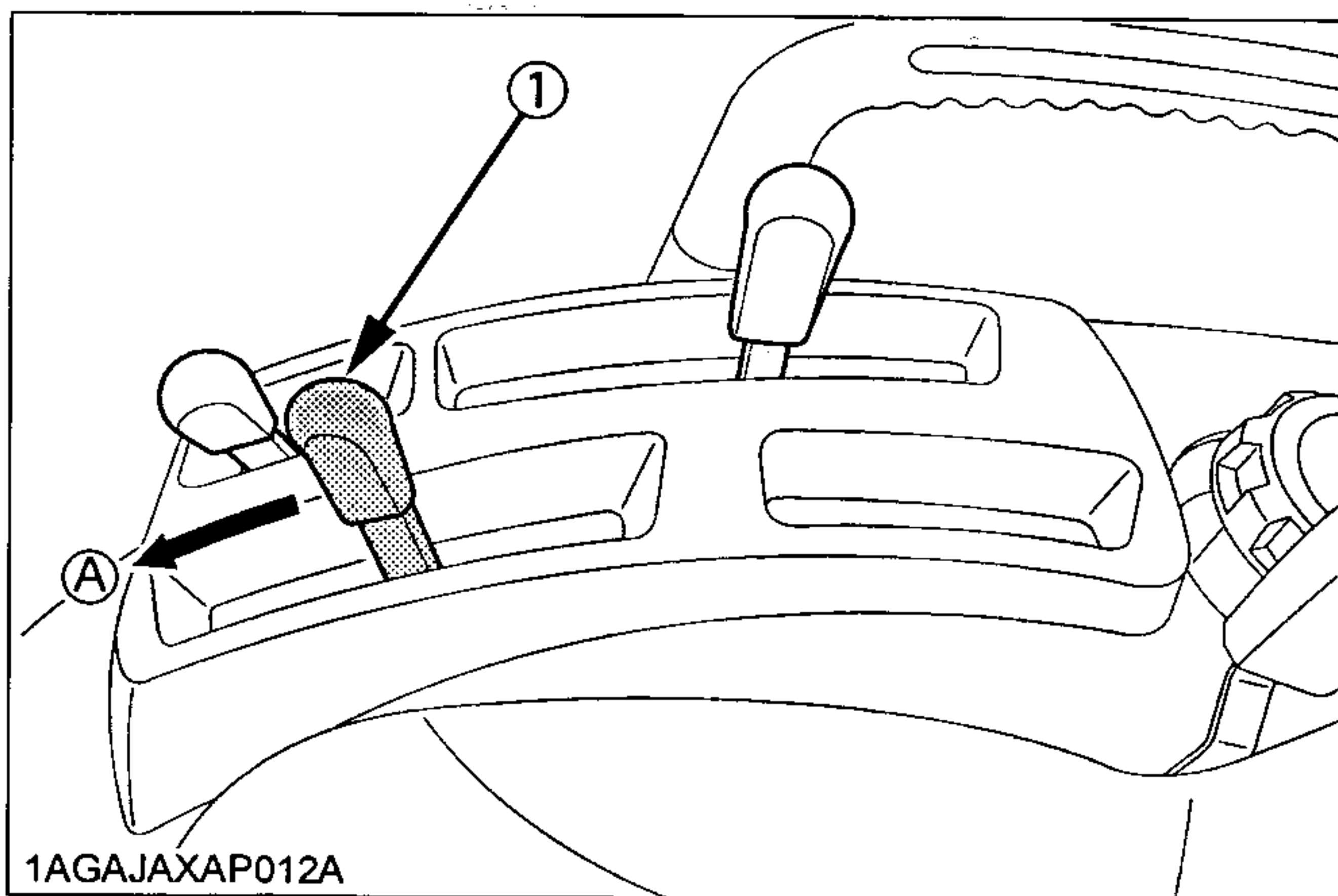

(1) Hydraulic control lever (A) "DOWN"

6. Set the throttle lever to about 1/2 way.

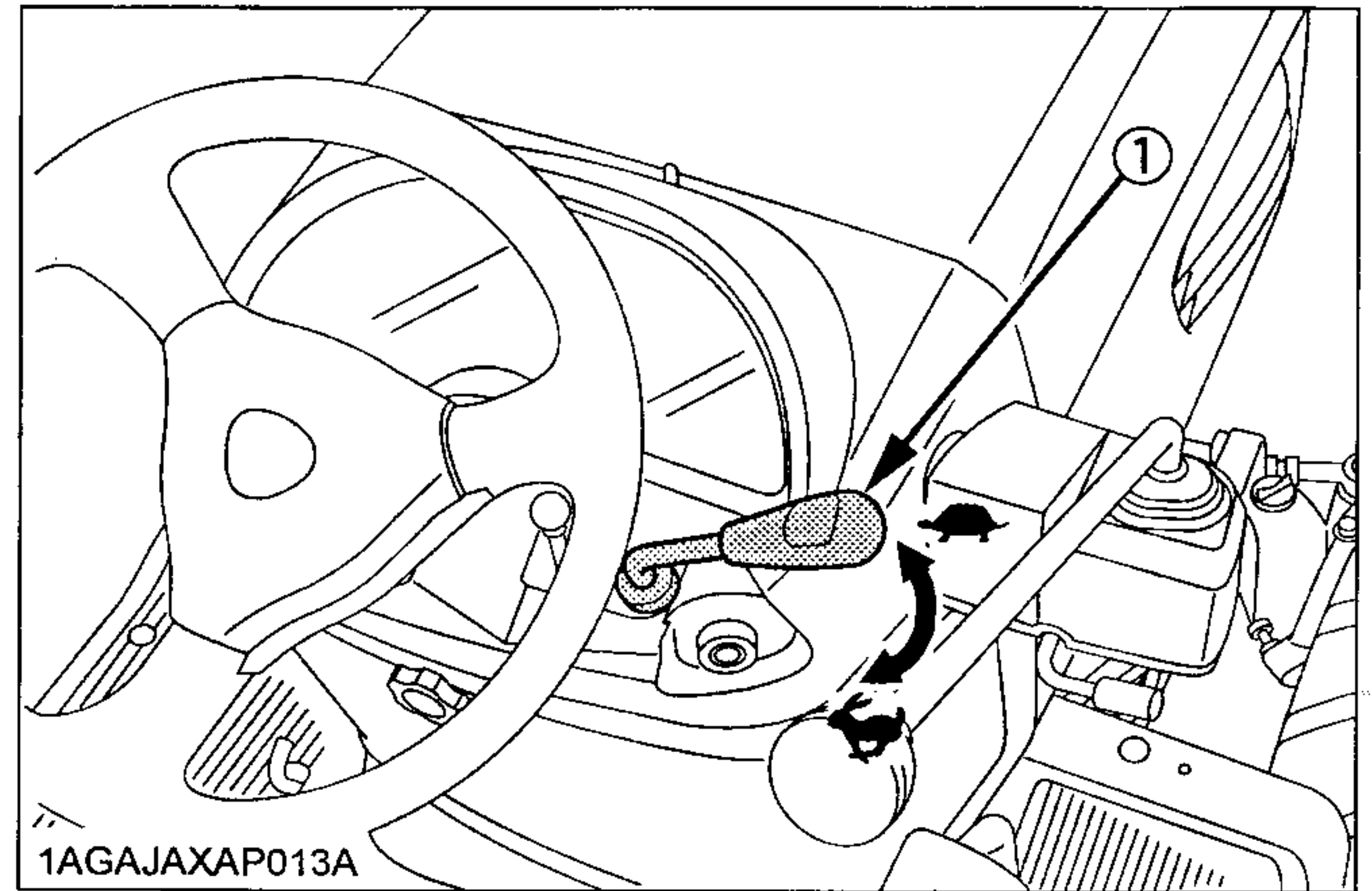

(1) Hand throttle lever
 ↗ "INCREASE"
 ↘ "DECREASE"

7. Insert the key into the key switch and turn it "ON".

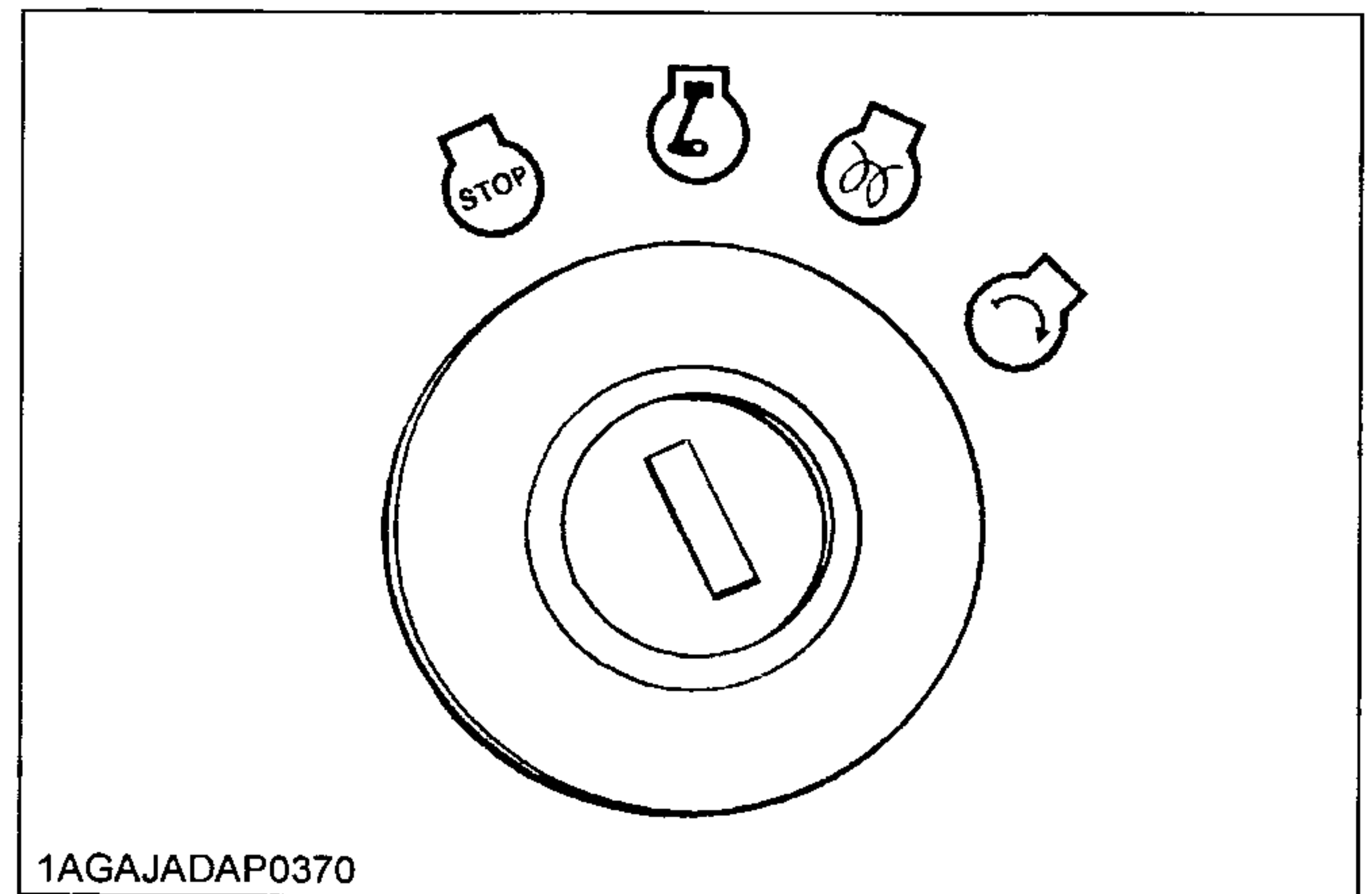

⏻ "OFF"
 ⏻ "ON"
 ⏻ "PREHEAT"
 ⏻ "START"

◆ Check Easy Checker(TM) Lamps:

- When the key is turned "ON", lamps (3) (4): only should come on. If trouble should occur at any location while the engine is running, the warning lamp corresponding to that location comes on.

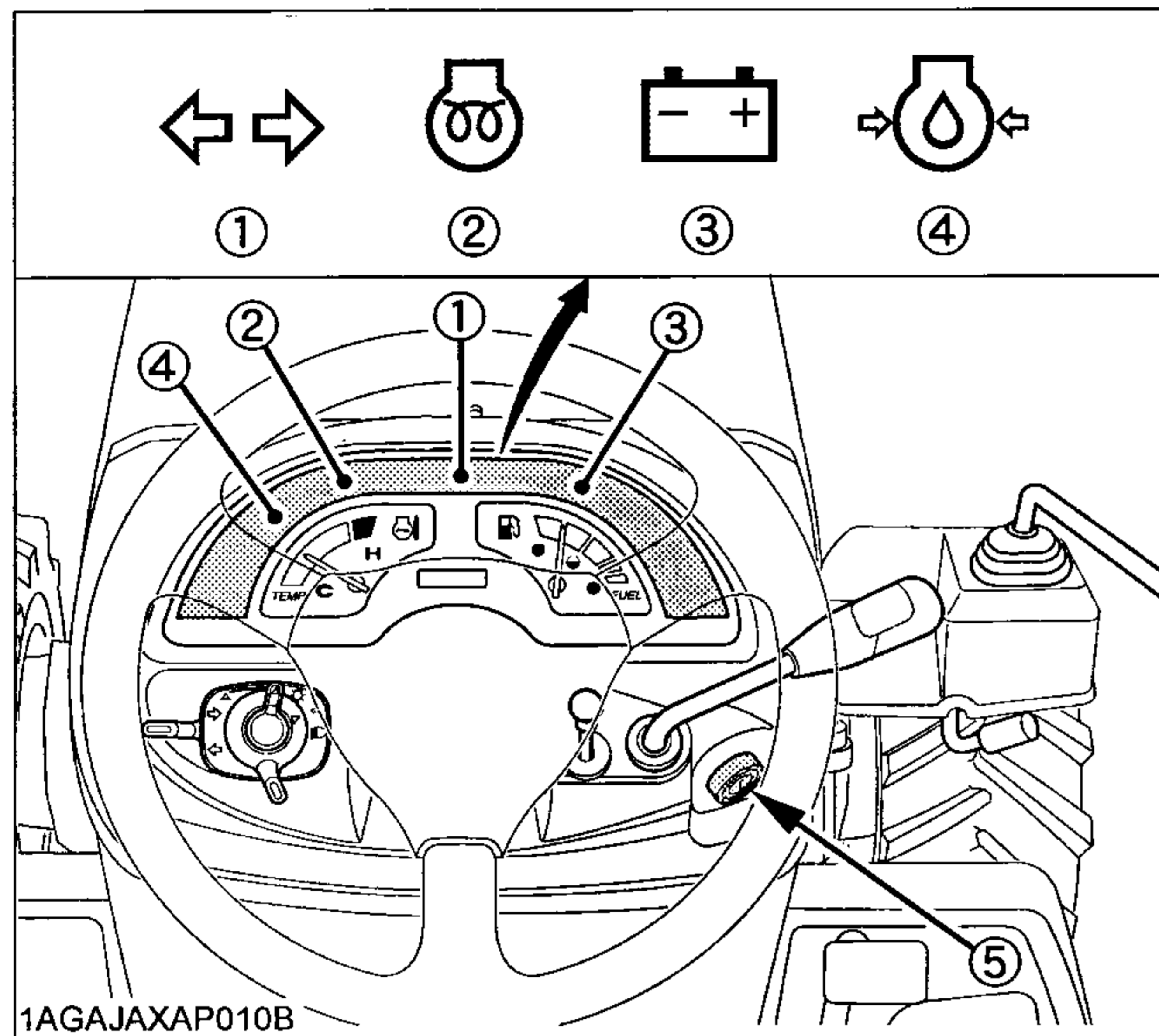

- Turn signal/Hazard light indicator
- Preheat
- Electrical charge
- Engine oil pressure
- Key switch

IMPORTANT :

- Daily checks with the Easy Checker(TM) only, are not sufficient. Never fail to conduct daily checks carefully by referring to Daily Check section. (See "DAILY CHECK" in Periodic Service Section)

8. Turn the key to "PREHEAT" position and hold it for about 2 to 3 seconds.

For the appropriate preheating time, refer to the table below:

Temperature	Preheating Time
Over 0°C (32°F)	2 to 3 sec.
0 to -5°C (32 to 23°F)	5 sec.
-5 to -15°C (23 to 5°F)	10 sec.

NOTE :

- Glow plug indicator (2) comes on while engine is being preheated.

9. Turn the key to "START" position and release when the engine starts.

IMPORTANT :

- Because of safety devices, the engine will not start except when the speed control pedal is in "NEUTRAL" position and the PTO clutch lever is in "OFF" position respectively.

■ Cold Weather Starting

When the ambient temperature is below -5°C (23°F) and the engine is very cold. If the engine fails to start after 10 seconds, turn off the key for 30 seconds. Then repeat steps 8 and 9. To protect the battery and the starter, make sure that the starter is not continuously turned for more than 30 seconds.

■ Block Heater (Option)

A block heater is available as an option from your dealer. It will assist you in starting your tractor when the ambient temperature is below -15°C (5°F).

10. Check to see that all the lamps on the Easy Checker(TM) are "OFF"

If the lamp is still "ON", immediately stop the engine and determine the cause.

STOPPING THE ENGINE

- After slowing the engine to idle, turn the key to "OFF".
- Remove the key.

NOTE :

- If key does not stop the engine, consult your local KUBOTA Dealer.

WARMING UP



CAUTION

To avoid personal injury:

- Be sure to set the parking brake during warm-up.
- Be sure to set all shift levers to "NEUTRAL" positions and to place PTO lever in "OFF" position during warm-up.

For five minutes after engine start-up, allow engine to warm up without applying any load, this is to allow oil to reach every engine part. If load should be applied to the engine without this warm-up period, trouble such as seizure, breakage or premature wear may develop.

■ Warm-up and Transmission Oil in the Low Temperature Range

Hydraulic oil serves as transmission fluid. In cold weather, the oil may be cold with increased viscosity. This can cause delayed oil circulation or abnormally low hydraulic pressure for some time after engine start-up. This in turn can result in premature wear in the hydraulic system or malfunctions such as resistance in the speed control pedal and difficulty engaging the range gear shift lever. To prevent the above, observe the following instructions: Warm up the engine at about 50% of rated rpm according to the table below:

Ambient temperature	Warm-up time requirement
Above 0°C (32°F)	At least 5 minutes
0 to -10°C (32 to 14°F)	5 to 10 minutes
-10 to -20°C (14 to -4°F)	10 to 15 minutes
Below -20°C (-4°F)	More than 15 minutes

IMPORTANT :

- Do not operate the tractor under full load condition until it is sufficiently warmed up.

JUMP STARTING



CAUTION

To avoid personal injury:

- Battery gases can explode. Keep cigarettes, sparks, and flames away from battery.
- If tractor battery is frozen, do not jump start engine.
- Do not connect other end of negative (-) jumper cable to negative (-) terminal of tractor battery.
- When carrying on the following steps 4 and 13, do not allow the positive (+) terminal of the battery to touch other parts.

When jump starting engine, follow the instructions below to safely start the engine.

1. Bring helper vehicle with a battery of the same voltage as disabled tractor within easy cable reach. "THE VEHICLES MUST NOT TOUCH".
2. Engage the parking brakes of both vehicles and put the shift levers in "NEUTRAL". Shut both engines off.
3. Put on safety goggles and rubber gloves.
4. Take the dead battery out and put it on the step.
5. Ensure the vent caps are securely in place. (if equipped)
6. Cover vent holes with damp rags. Do not allow the rag to touch the battery terminals.
7. Attach the red clamp to the positive (red, (+) or pos.) terminal of the dead battery and clamp the other end of the same cable to the positive (red, (+) or pos.) terminal of the helper battery.
8. Clamp the other cable to the negative (black, (-) or neg.) terminal of the helper battery.
9. Clamp the other end to the engine block or frame of the disabled tractor as far from the dead battery as possible.
10. Start the helper vehicle and let its engine run for a few moments. Start the disabled tractor.
11. Disconnect the jumper cables in the exact reverse order of attachment. (Steps 9, 8 and 7).
12. Remove and discard the damp rags.
13. Put the battery back and fix it.

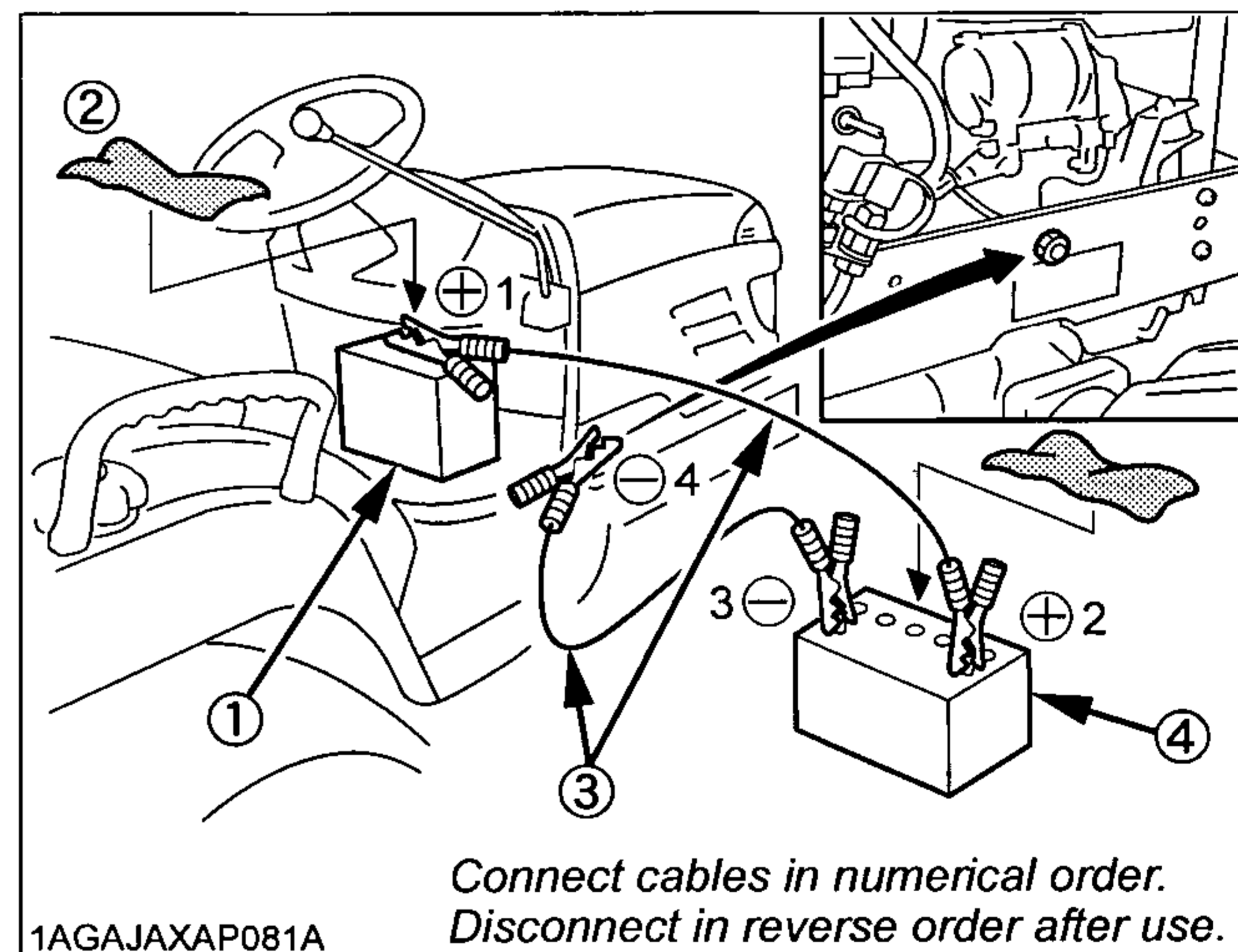

- (1) Dead battery
- (2) Lay a damp rag over the vent caps
- (3) Jumper cables
- (4) Helper battery

IMPORTANT :

- This machine has a 12volt negative (-) ground starting system.
 - Use only same voltage for jump starting.
 - Use of a higher voltage source on tractors electrical system could result in severe damage to tractors electrical system.
- Use only matching voltage source when "Jump starting" a low or dead battery condition.

OPERATING THE TRACTOR

OPERATING NEW TRACTOR

How a new tractor is handled and maintained determines the life of the tractor.

A new tractor just off the factory production line has been, of course, tested, but the various parts are not accustomed to each other, so care should be taken to operate the tractor for the first 50 hours at a slower speed and avoid excessive work or operation until the various parts become "broken-in." The manner in which the tractor is handled during the "breaking-in" period greatly affects the life of your tractor. Therefore, to obtain the maximum performance and the longest life of the tractor, it is very important to properly break-in your tractor. In handling a new tractor, the following precautions should be observed.

■ Do not Operate the Tractor at Full Speed for the First 50 Hours.

- Do not start quickly or apply the brakes suddenly.
- In winter, operate the tractor after fully warming up the engine.
- Do not run the engine at speeds faster than necessary.
- On rough roads, slow down to suitable speeds.
Do not operate the tractor at fast speed.

The above precautions are not limited only to new tractors, but to all tractors. But it should be especially observed in the case of new tractors.

■ Changing Lubricating Oil for New Tractors

The lubricating oil is especially important in the case of a new tractor. The various parts are not "broken-in" and are not accustomed to each other; small metal grit may develop during the operation of the tractor; and this may wear out or damage the parts. Therefore, care should be taken to change the lubricating oil a little earlier than would ordinarily be required.

For further details of change interval hours.
(See "MAINTENANCE" section)

STARTING

1. Adjusting the operator's position.

■ Operator's Seat



CAUTION

To avoid personal injury:

- Make adjustments to the seat only while the tractor is stopped.
- Make sure that the seat is completely secured after each adjustment.
- Do not allow any person other than the driver to ride on the tractor.

◆ Travel adjustment

Pull up the position adjust lever and slide the seat backward or forward, as required. The seat will lock in position when the lever is released.

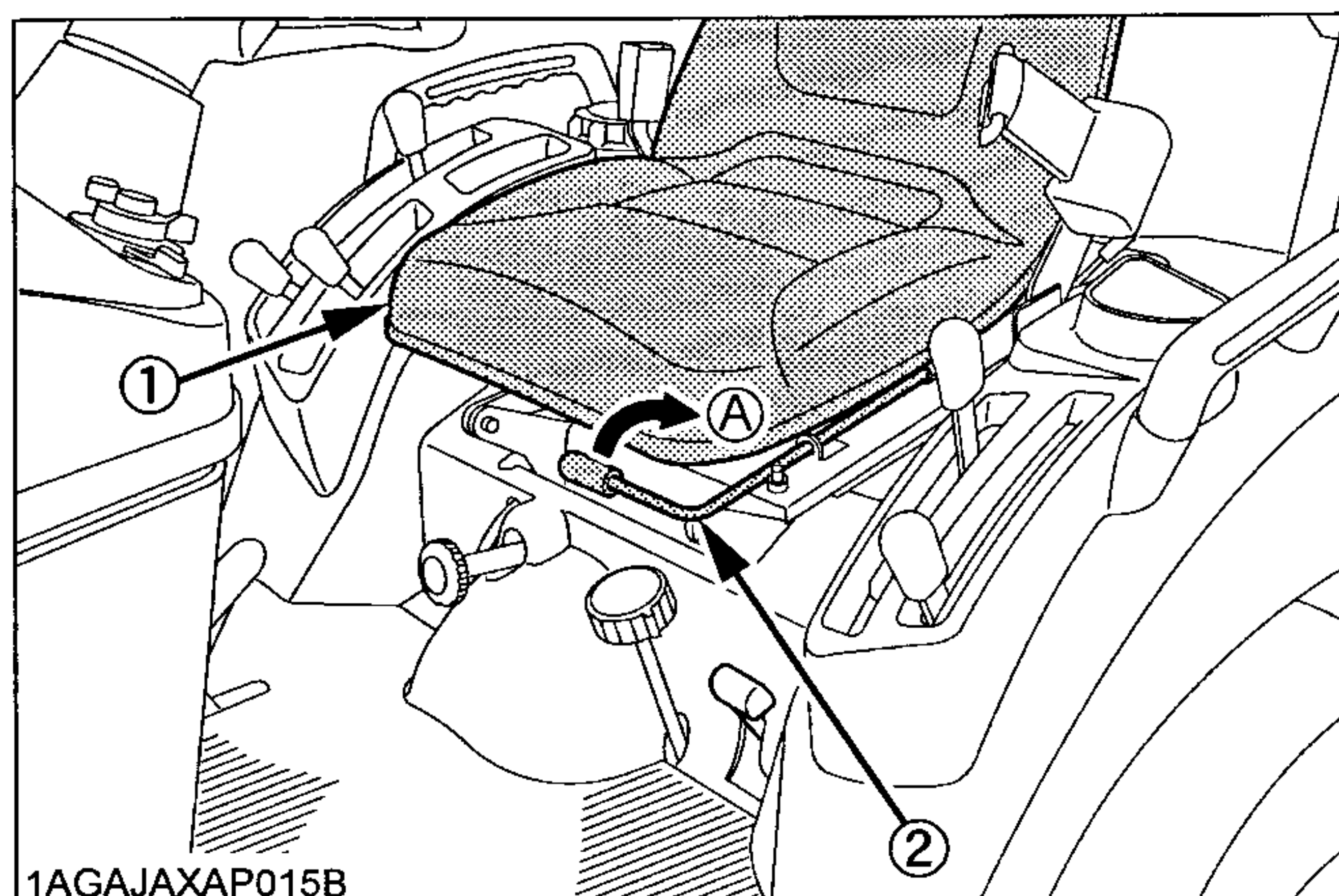

(1) Seat

(2) Position adjust lever

(A) "PULL UP"

IMPORTANT :

- After adjusting the operator's seat, be sure to check that the seat is properly locked.

■ Seat Belt

⚠ CAUTION

To avoid personal injury:

- Always use the seat belt when the ROPS is installed.
- Do not use the seat belt if the tractor is not equipped with ROPS.

Adjust the seat belt for proper fit and connect to the buckle. The seat belt is auto-locking retractable type.

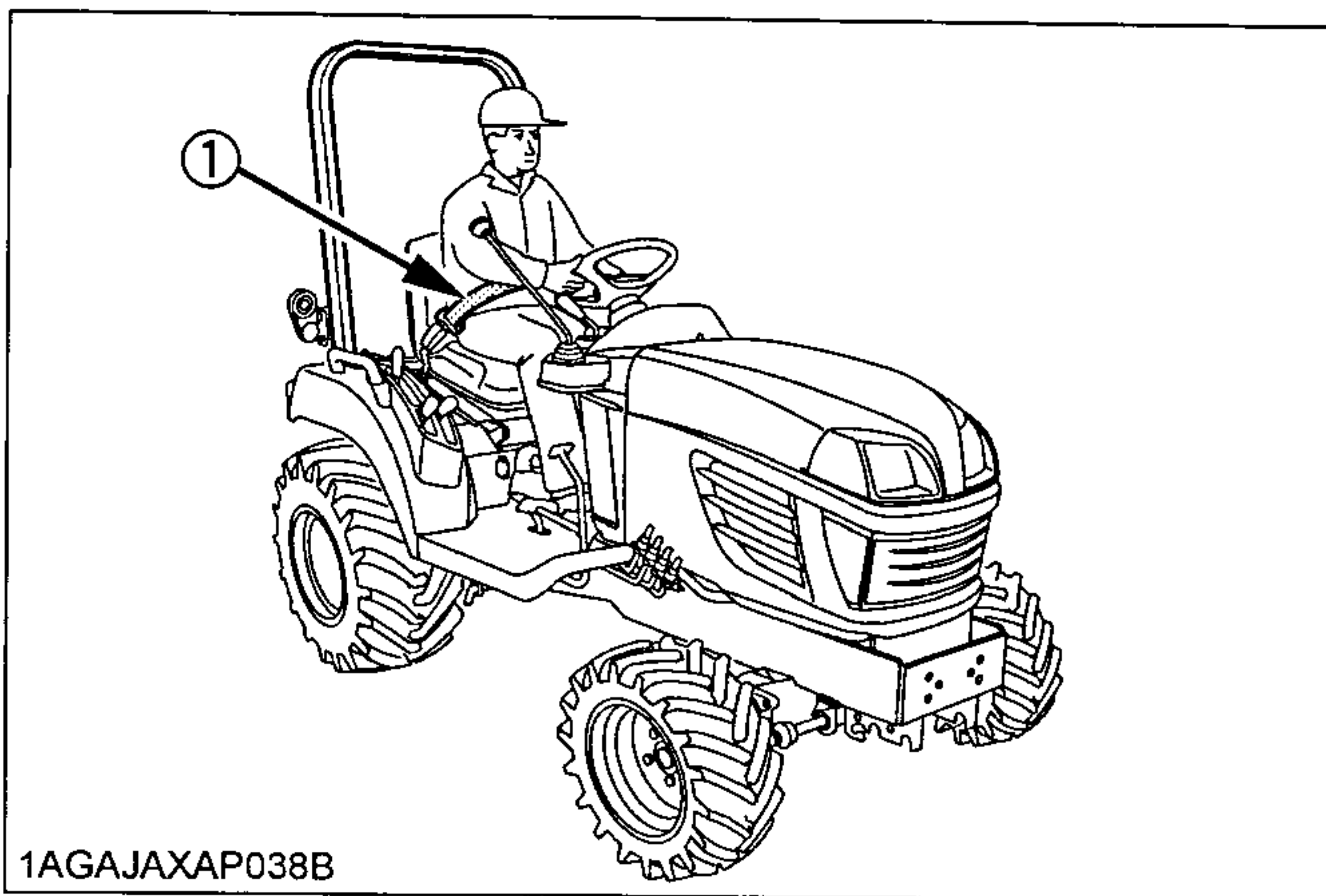

(1) Seat belt

2. Selecting Light Switch Positions.

■ Head Light Switch

- (A) Head lights "ON".
- (B) Head lights "OFF".

■ Hazard Light Switch

When hazard light switch is turned counter-clockwise, the hazard lights flash along with the indicator on the instrument panel. Turn the switch clockwise to turn off the light.

- (A) Hazard lights "ON".
- (B) Hazard lights "OFF".

■ Turn Signal Light Switch

To indicate a right turn, turn the switch clockwise.
To indicate a left turn, turn the switch counter-clockwise.
When the left or right turn signal is activated in combination with the hazard lights, the indicated turning light will flash and the other will stay on.

NOTE :

- Be sure to return switch to center position after turning.

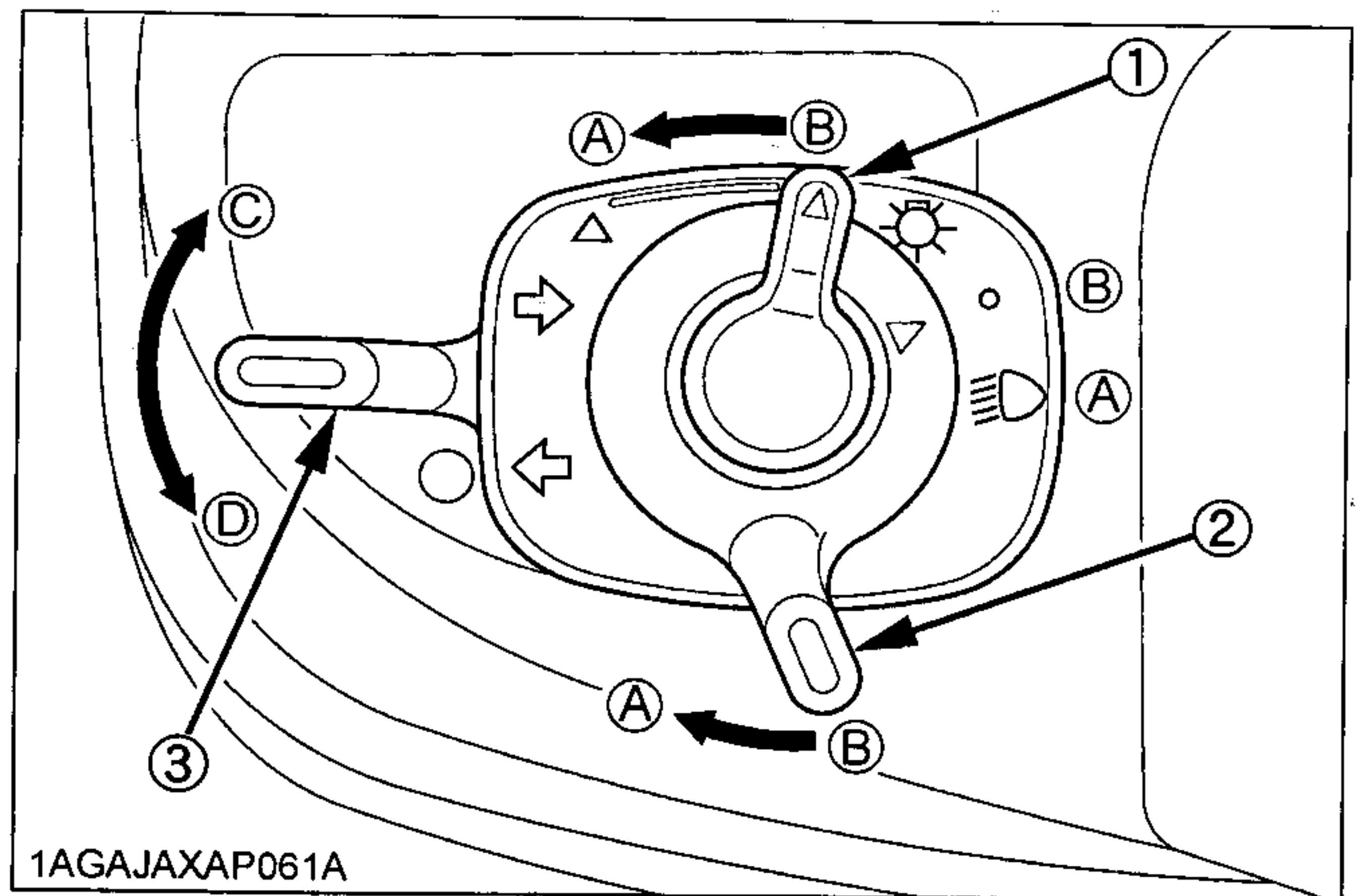

- (1) Hazard light switch
- (2) Head light switch
- (3) Turn signal light switch
- (A) "ON"
- (B) "OFF"
- (C) "RIGHT TURN"
- (D) "LEFT TURN"

3. Checking the Brake Pedal.

■ Brake Pedal

Make sure to latch the brake pedal with the parking brake lock pedal. Use both right and left feet for the procedure.

⚠ CAUTION

To avoid personal injury:

- An accident may occur if the tractor is suddenly braked, such as by heavy towed loads shifting forward or loss of control.
- The braking characteristics are different between two and four wheel drive. Be aware of the difference and use carefully.
- When driving on icy, wet or loose surfaces, make sure the tractor is correctly ballasted to avoid skidding and loss of steering control. Operate at reduced speed.

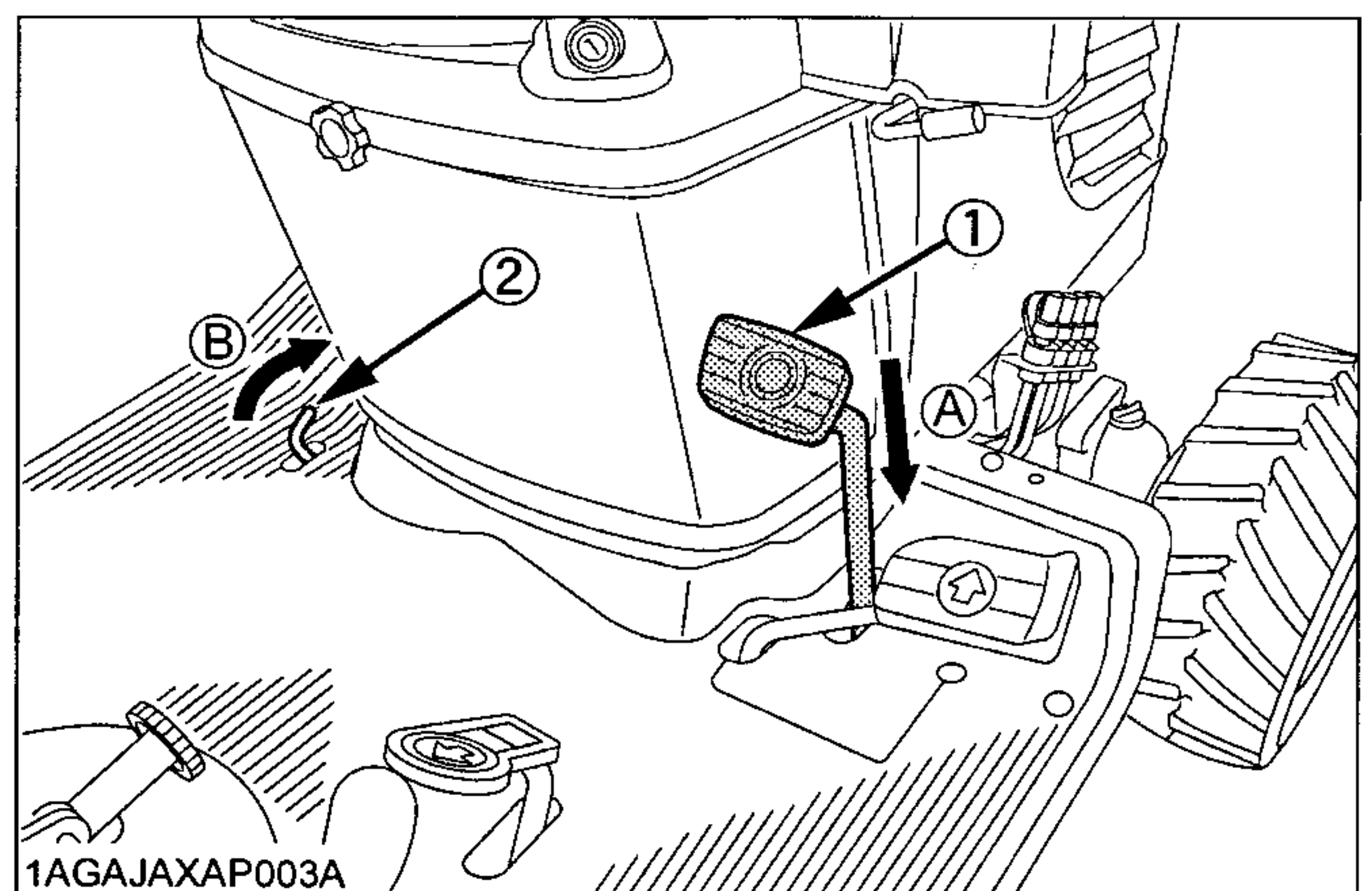

- (1) Brake pedal
- (2) Parking brake lock pedal
- (A) "DEPRESS"
- (B) "PUSH FORWARD WHILE DEPRESSING (1)"

**4. Raise the Implement.
(see "HYDRAULIC UNIT" section)**

Move the hydraulic control lever rearward.

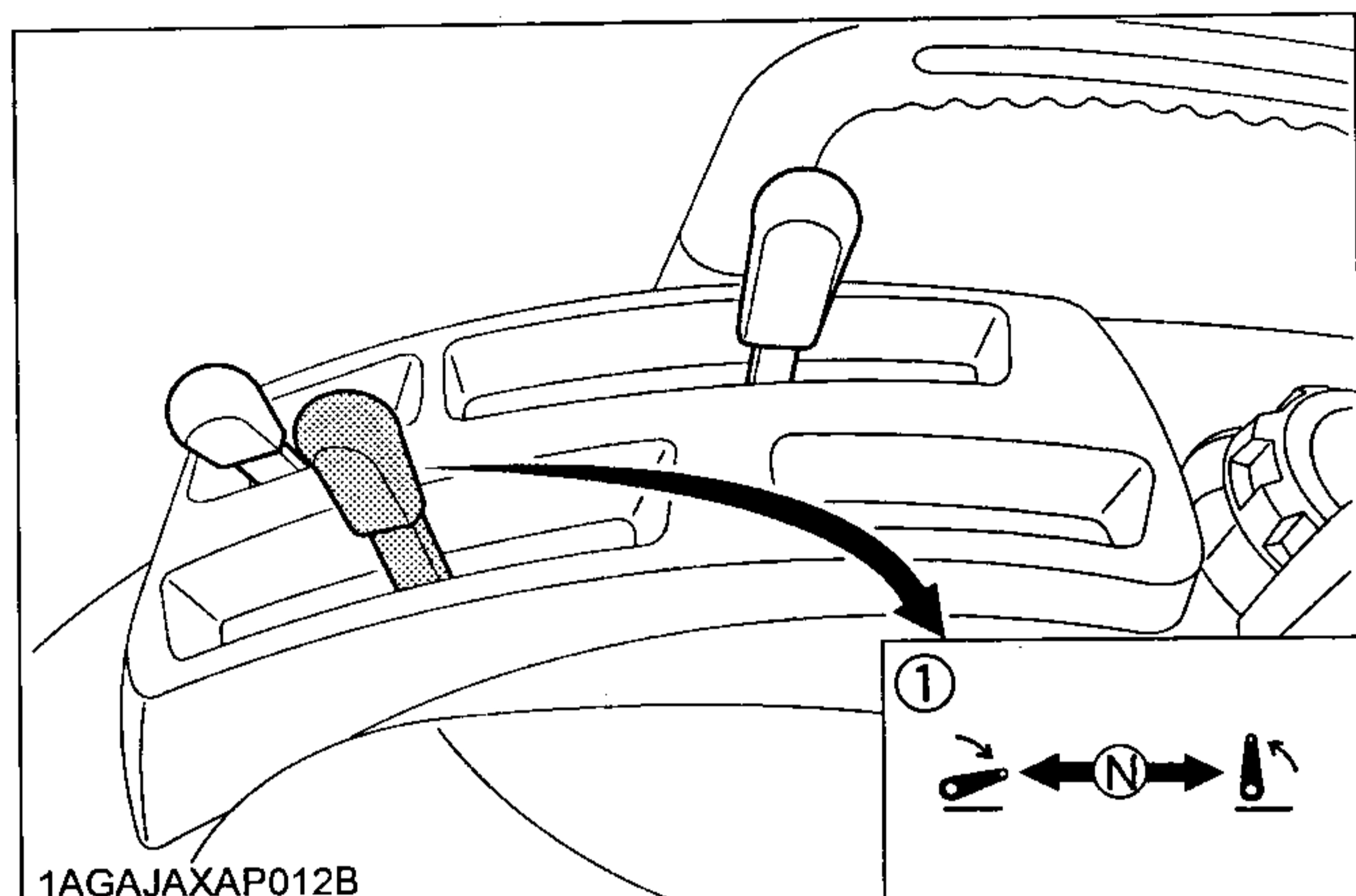

1AGAJAXAP012B
(1) Hydraulic control lever

↑ "RAISED"
(N) "NEUTRAL POSITION"
↓ "LOWERED"

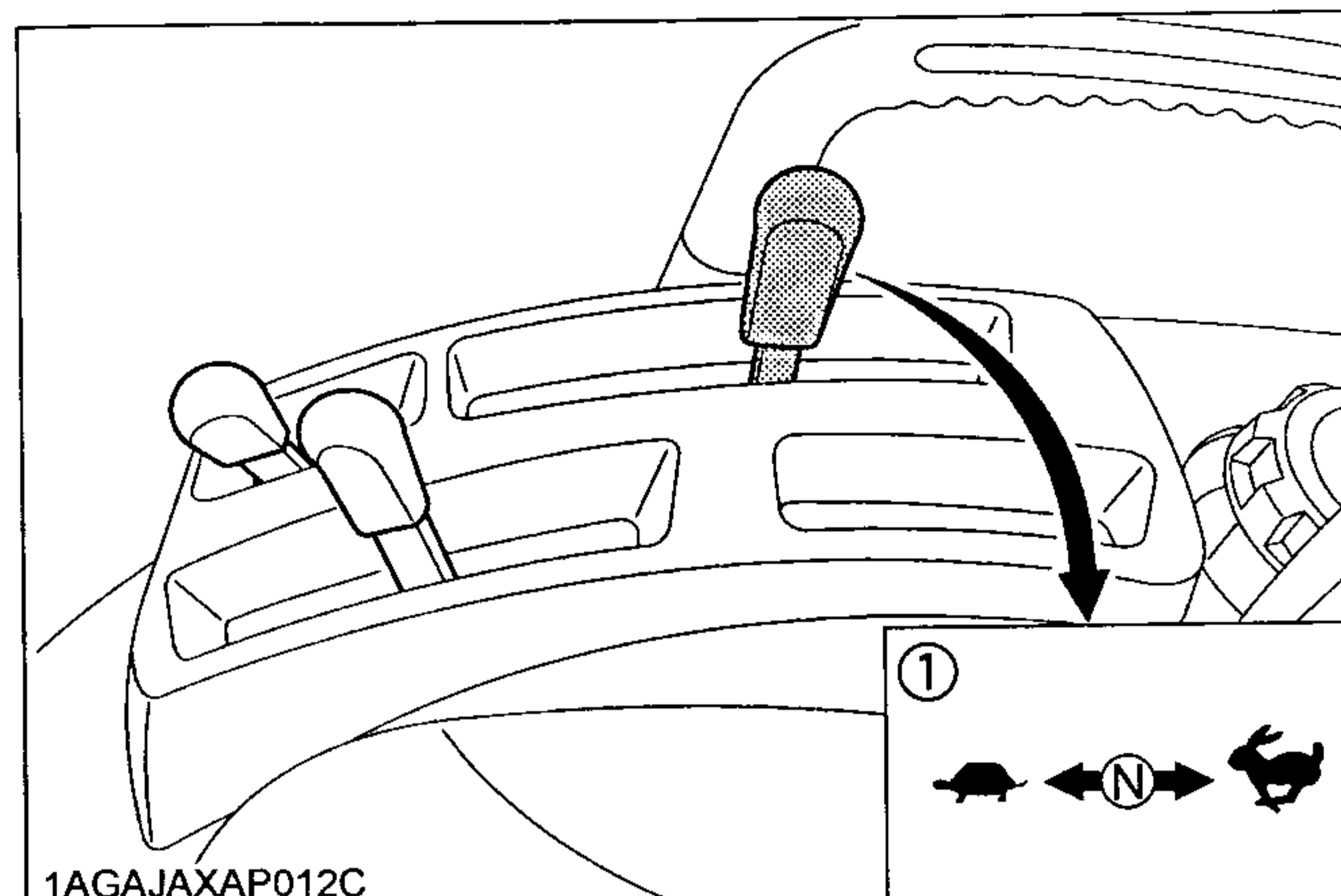

1AGAJAXAP012C

(1) Range gear shift lever
(Hi-Lo)

↑ "HIGH"
(N) "NEUTRAL POSITION"
↓ "LOW"

5. Selecting the Travel Speed.

Range Gear Shift Lever (Hi-Lo)

The range gear shift can only be shifted when tractor is completely stopped.



CAUTION

To avoid personal injury:

- Make sure the range shift lever is fully engaged into "H" or "L" position before climbing or descending a slope.

IMPORTANT :

Do not force the range gear shift lever.

- If it is difficult to shift the range shift lever into "NEUTRAL" position;
 - (1) Depress the brake pedal firmly for several seconds.
 - (2) Without reducing the brake pedal force, shift the range shift lever.
- If it is difficult to shift the range shift lever into "L" or "H" from "NEUTRAL" position;
 - (1) Slightly depress the speed control pedal to rotate the gears inside of transmission.
 - (2) Release the speed control pedal to "NEUTRAL" position.
 - (3) Shift the range shift lever.
- To avoid damage of transmission, stop tractor before shifting between ranges.

Front Wheel Drive Lever



CAUTION

To avoid personal injury:

- Do not engage the front wheel drive when traveling at road speed.
- When driving on icy, wet or loose surfaces, make sure the tractor is correctly ballasted to avoid skidding and loss of steering control. Operate at reduced speed and engage front wheel drive.
- An accident may occur if the tractor is suddenly braked, such as by heavy towed loads shifting forward or loss of control.
- The braking characteristics are different between two and four wheel drive. Be aware of the difference and use carefully.

Use the lever to engage the front wheels with the tractor stopped. Shift the lever to "ON" to engage the front wheel drive.

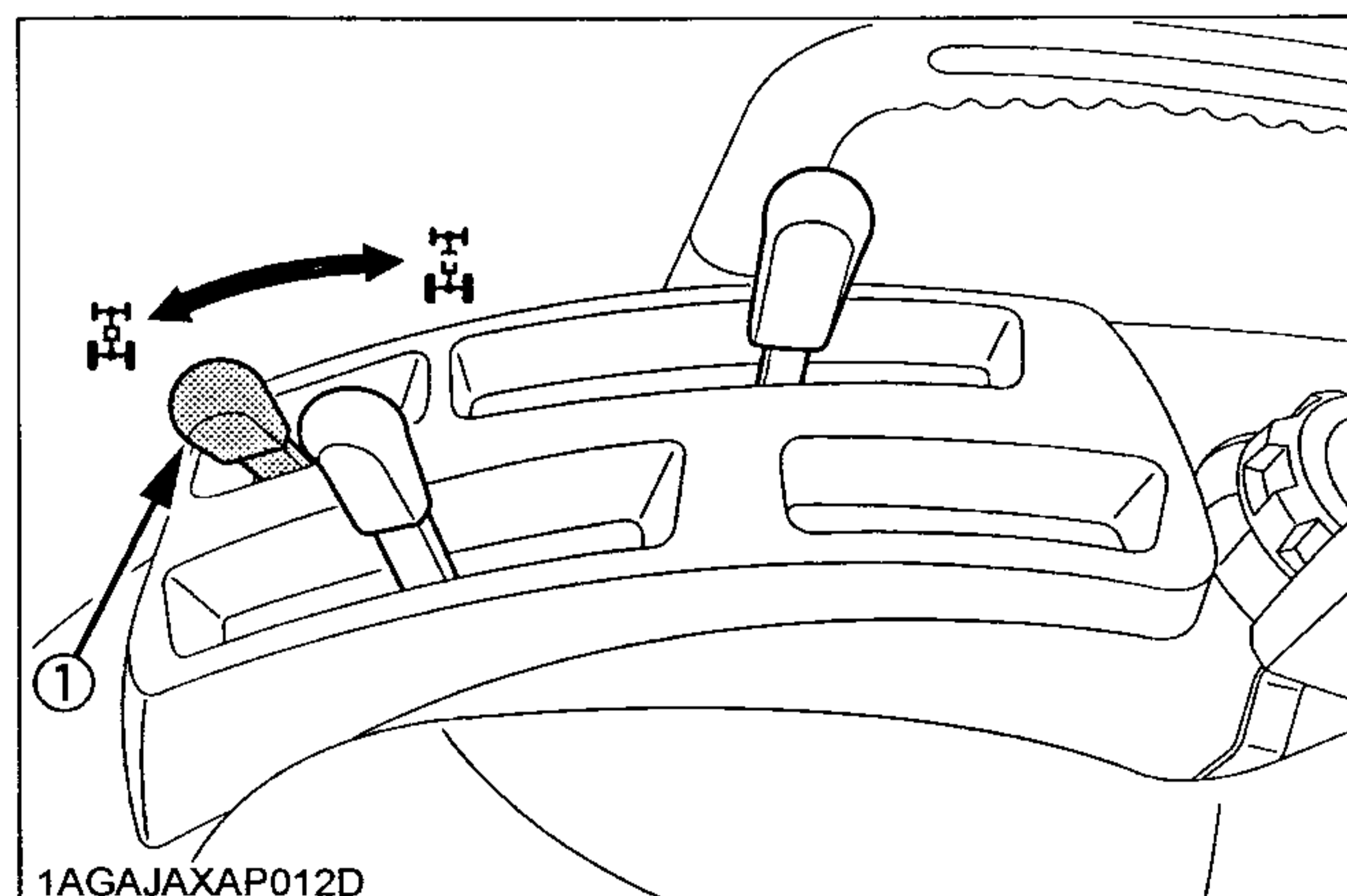

1AGAJAXAP012D

(1) Front wheel drive lever

↑ "ON"
↓ "OFF"

IMPORTANT :

- To avoid damage of transmission, when front wheel drive lever is not smoothly shifted, slightly step forward or rearward on speed control pedal.
- Tires will wear quickly if front wheel drive is engaged on paved roads.

◆ **Front wheel drive is effective for the following jobs:**

1. When greater pulling force is needed, such as working in a wet field, when pulling a trailer, or when working with a front-end loader.
2. When working in sandy soil.
3. When working on a hard soil where a rotary tiller might push the tractor forward.
4. Additional braking at reduced speed.

6. Accelerate the Engine.

■ **Hand Throttle Lever**

Pulling the throttle lever back increases engine speed, and pushing it forward decreases engine speed.

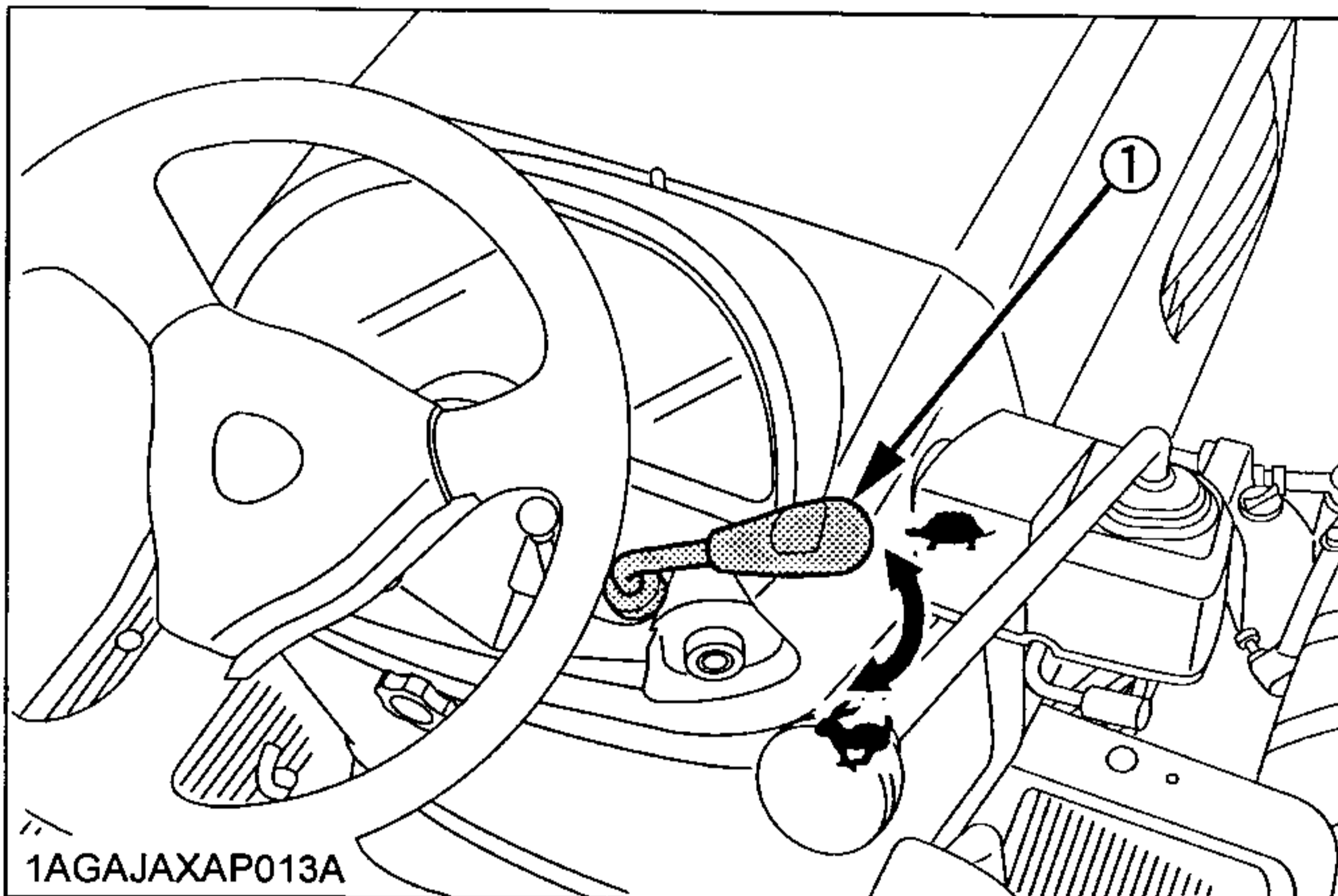

(1) Hand Throttle lever

↖ "INCREASE"
↘ "DECREASE"

7. Unlock the Parking Brake.

■ **Parking Brake Pedal**

To release the parking brake, depress the brake pedal again.

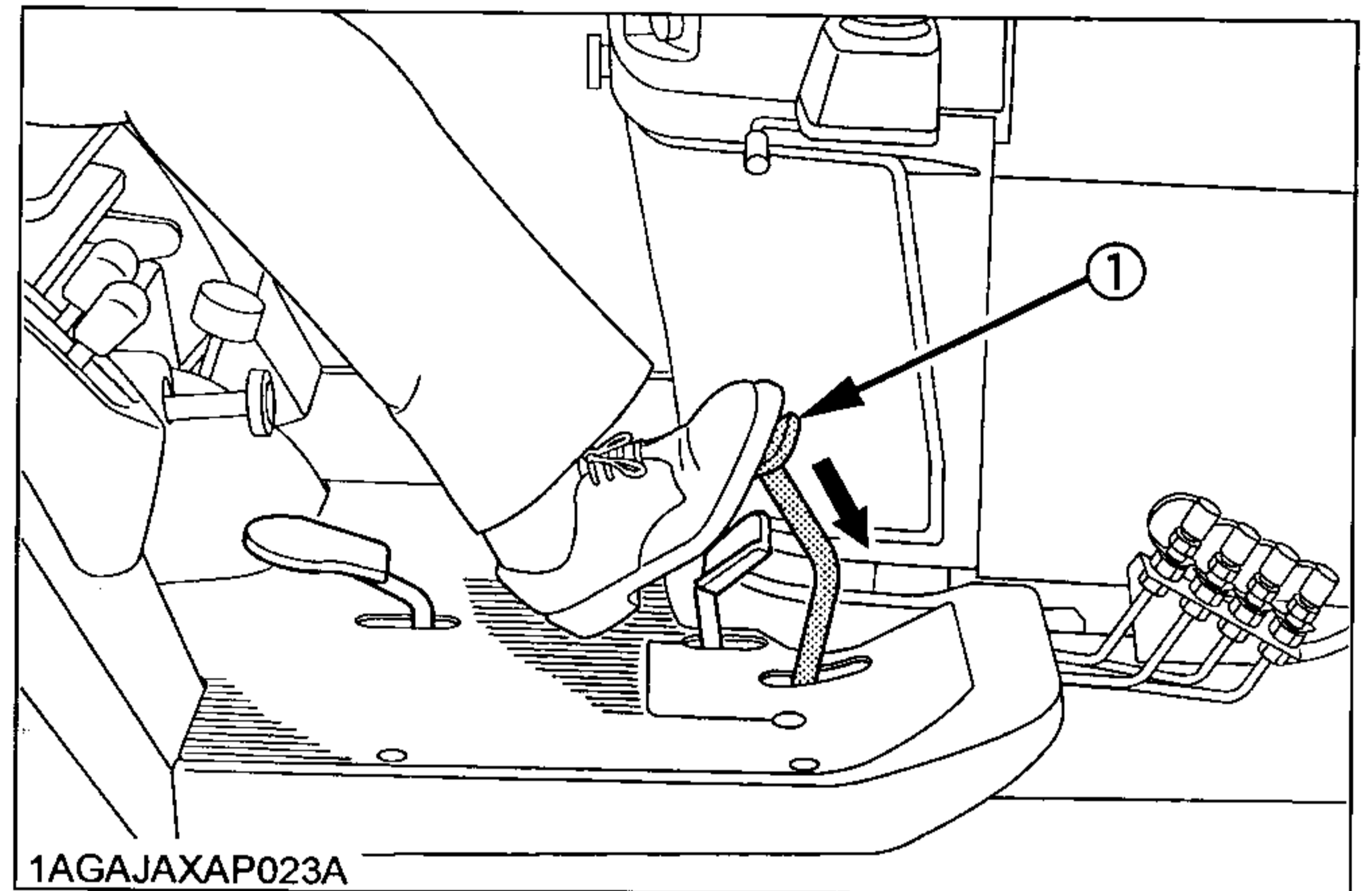

1AGA JAXAP023A

(1) Brake pedal

8. Depress the Speed Control Pedal.

■ **Speed Control Pedal**



WARNING

To avoid personal injury:

- Do not operate if tractor moves on level ground with foot off Speed Control Pedal.

Forward Pedal ⬆

Depress the forward pedal with the toe of your right foot to move forward.

Reverse Pedal ⬇

Depress the reverse pedal with the heel of your right foot to move backward.

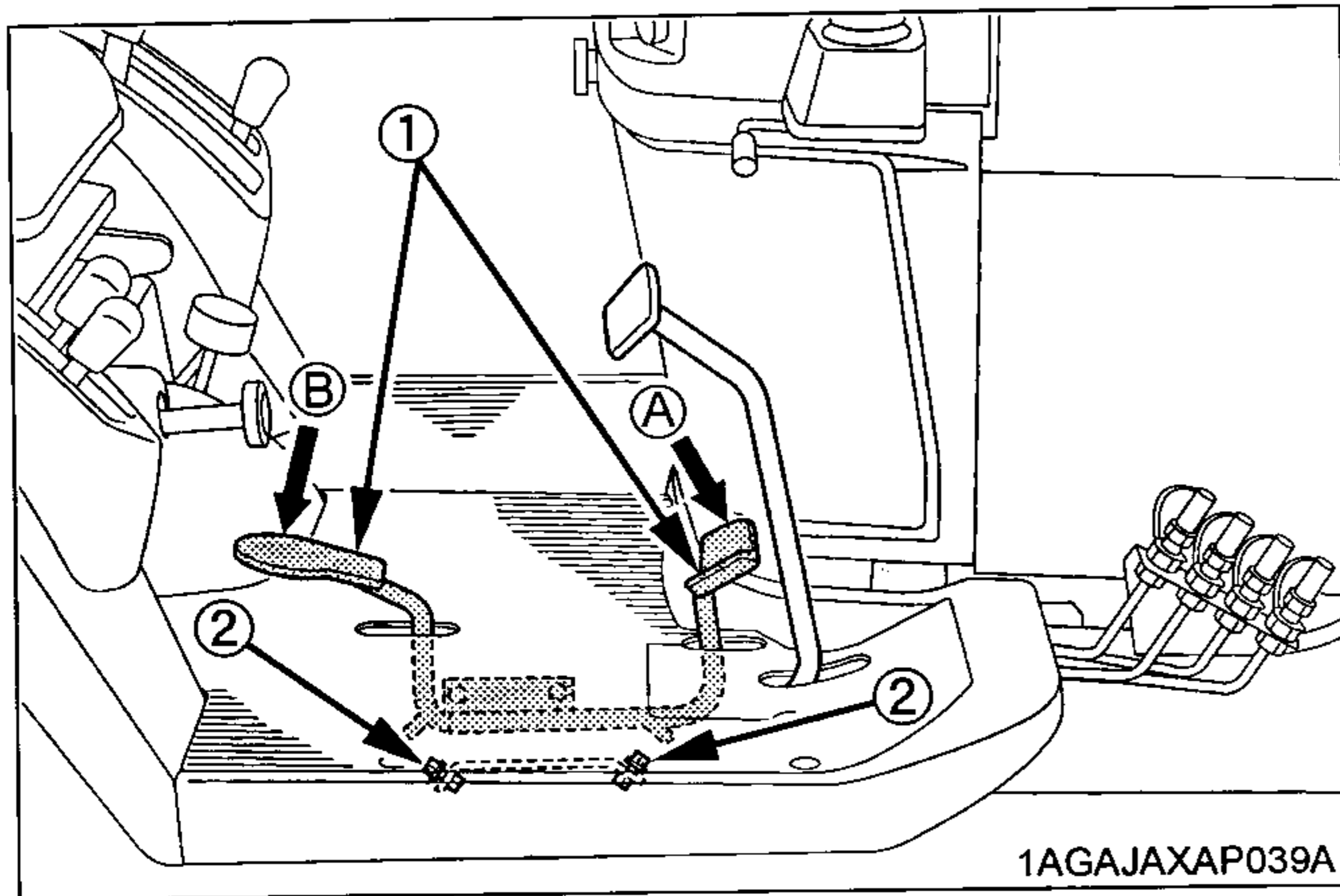

(1) Speed control pedal
(2) Stopper bolts
(A) "FORWARD"
(B) "REVERSE"

IMPORTANT :

- To prevent serious damage to the HST, do not adjust the stopper bolts.

NOTE :

- When you stand up from the seat with the speed control pedal stepped on, the engine will stop regardless of whether the machine is moving or not. This is because the tractor is equipped with Operator Presence Control system (OPC).

■ Speed Set Device (BX2350)

The Speed Set Device is designed for tractor operating efficiency and operator's comfort. This device will provide a constant forward operating speed by mechanically holding the speed control pedal at a selected position.

◆ To engage Speed Set Device

1. Accelerate speed to desired level using Speed Control Pedal.
2. Push and hold the speed set rod downward to "ON" position.
3. Release Speed Control Pedal.
4. Release the speed set rod and desired speed will be maintained.

◆ To disengage Speed Set Device

- Depress the brake pedal.

NOTE :

- If you step on the pedal on the forward acceleration side, the speed set device will disengage.
- Speed set device will not operate in reverse.

IMPORTANT :

- To prevent the damage of speed set device, do not depress the reverse pedal when the speed set device is engaged.

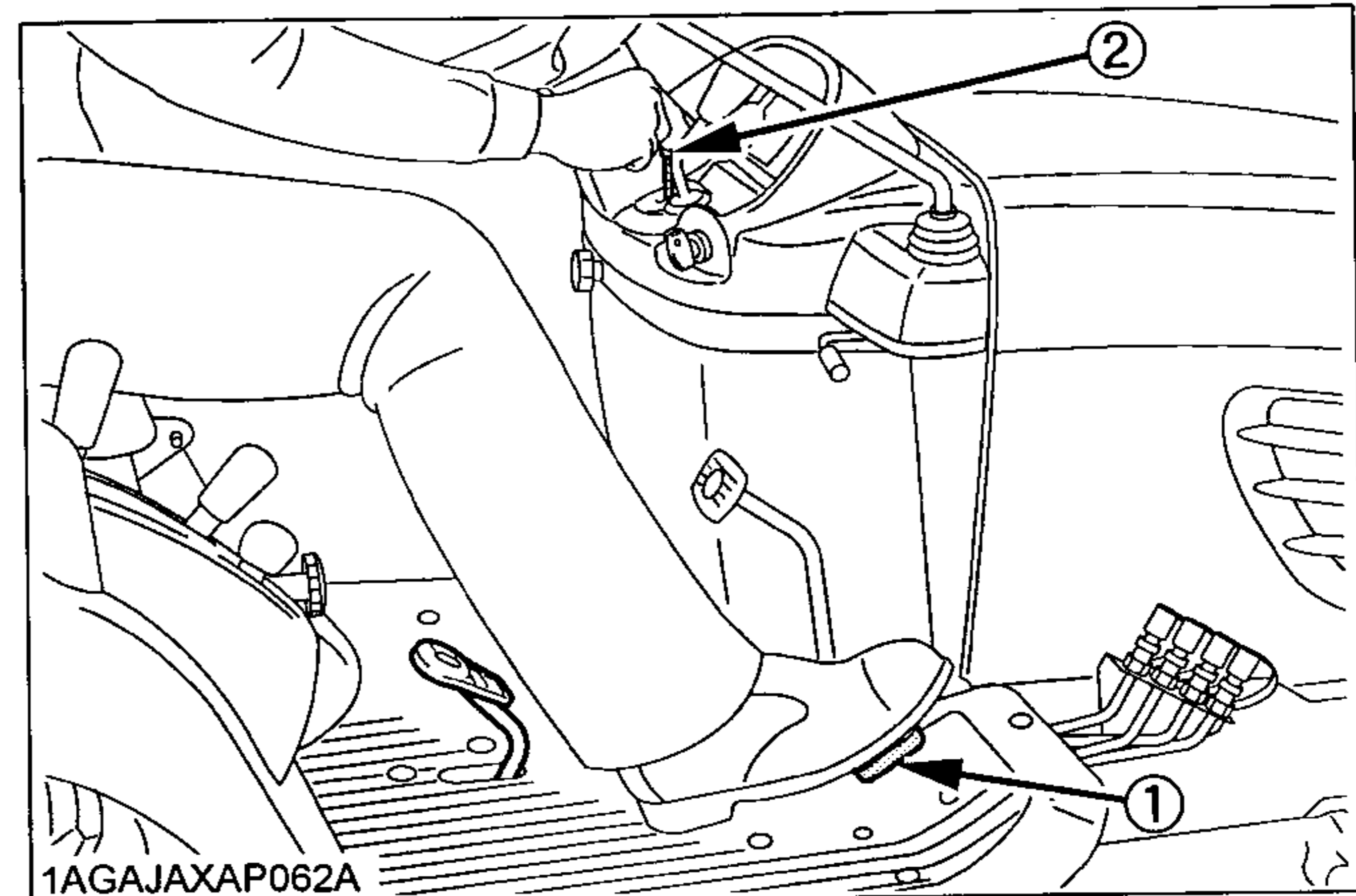

1AGAJAXAP062A

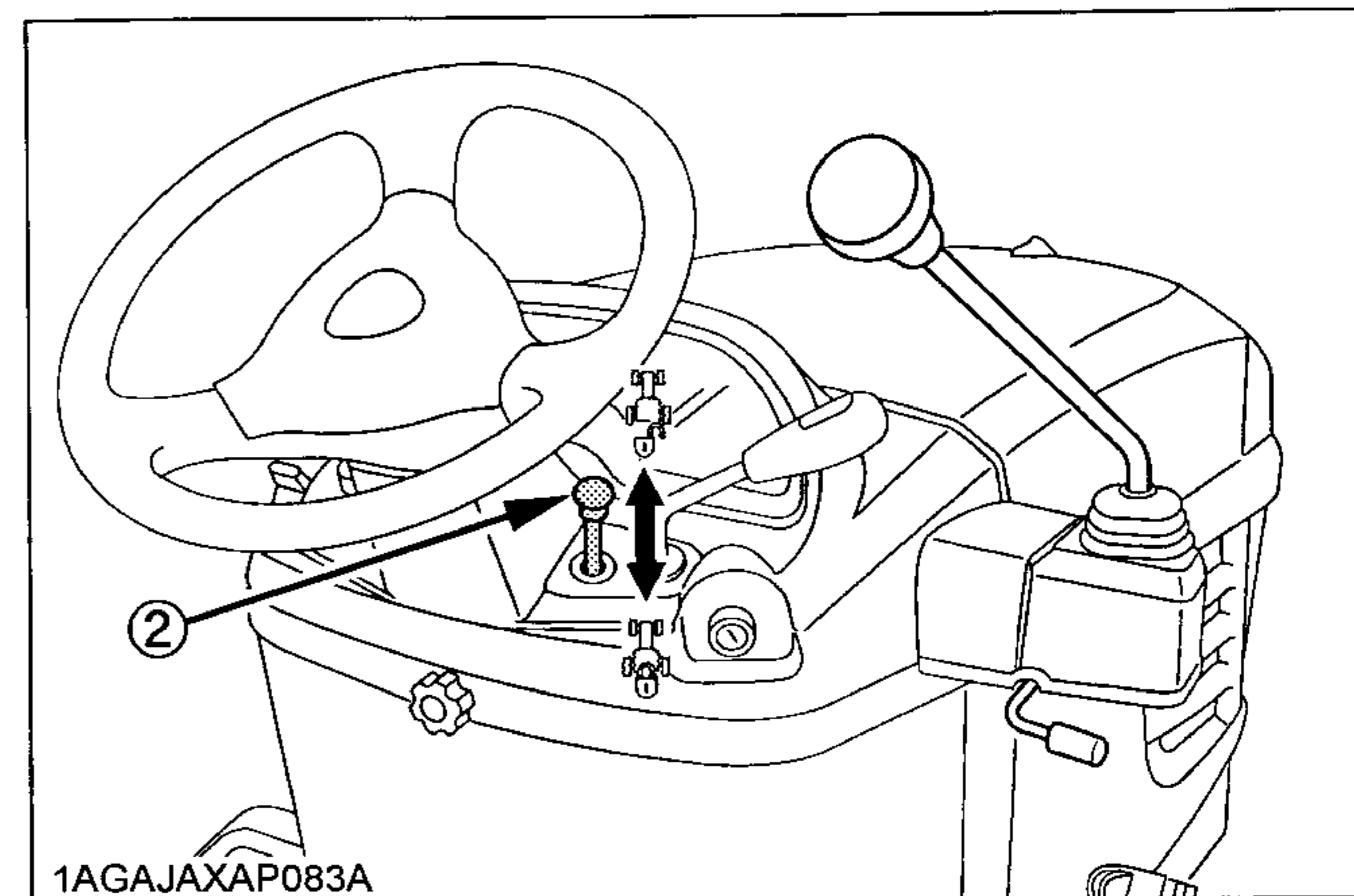

1AGAJAXAP083A

(1) Speed control pedal
(2) Speed set rod

☑ "ON"
☒ "OFF"

STOPPING

■ Stopping

1. Slow the engine down.
2. Step on the brake pedal.
3. After the tractor has stopped, disengage the PTO, lower the implement to the ground, shift the transmission to "NEUTRAL" and set the parking brake.

CHECK DURING DRIVING

■ Immediately Stop the Engine if:

- The engine suddenly slows down or accelerates,
- Unusual noises suddenly are heard,
- Exhaust fumes suddenly become very dark,

While driving, make the following checks to see that all the parts are functioning normally.

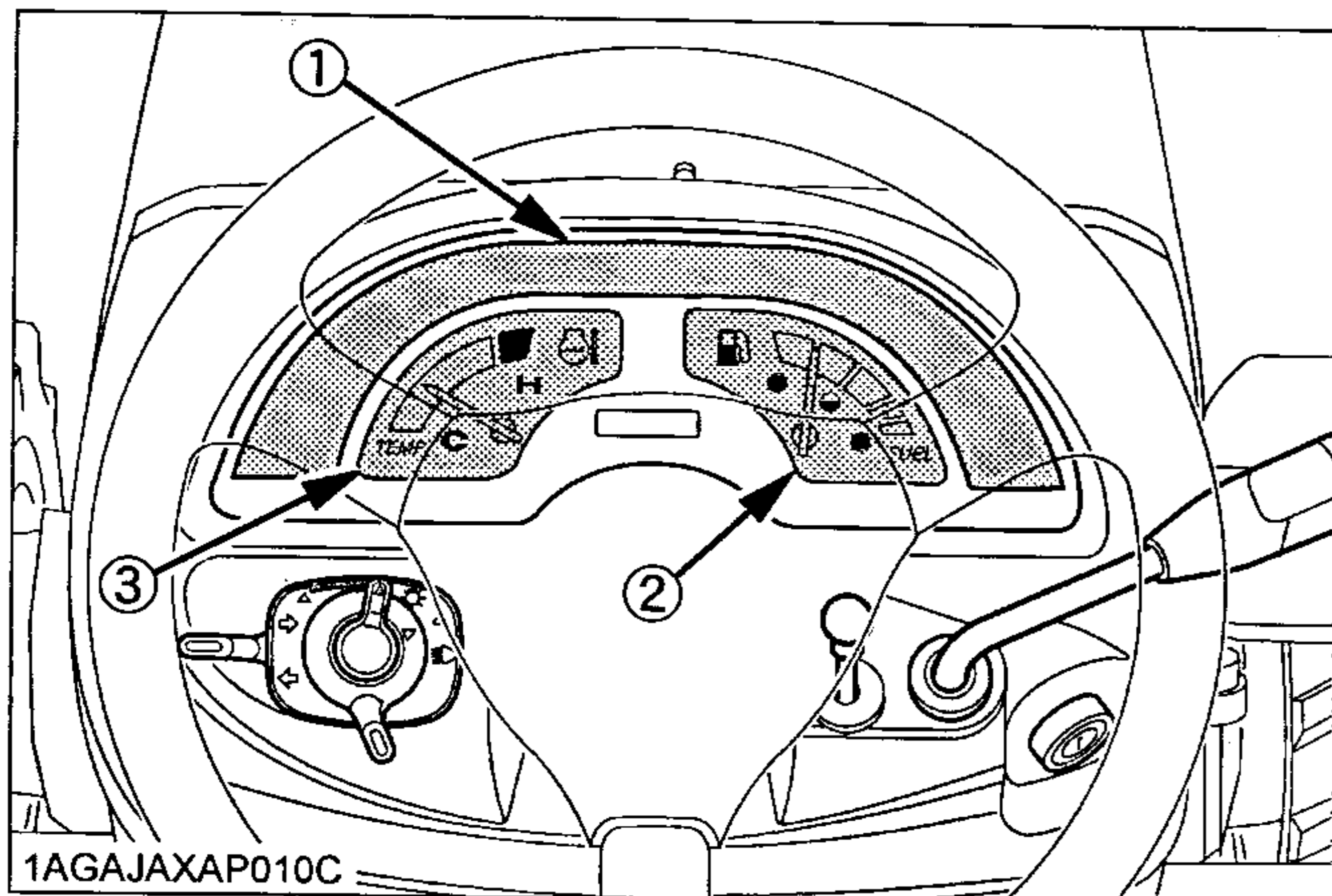

- (1) Easy checker(TM)
 (2) Fuel gauge
 (3) Coolant temperature gauge

■ Easy Checker(TM)

If the warning lamps in the Easy Checker(TM) come on during operation, immediately stop the engine, and find the cause as shown below.

Never operate the tractor while Easy Checker(TM) lamp is "ON".



Engine oil pressure

If the oil pressure in the engine goes below the prescribed level, the indicator in the Easy Checker(TM) will come on.

If this should happen during operation, and it does not go off when the engine is accelerated to more than 1000 rpm, check level of engine oil. (See "Checking Engine Oil Level" in daily check in Periodic Service section)

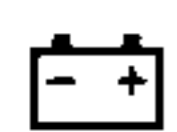

Electrical charge

If the alternator is not charging the battery, the indicator in the Easy Checker(TM) will come on. If this should happen during operation, check the electrical charging system or consult your local KUBOTA Dealer.

NOTE:

- For checking and servicing of your tractor, consult your local KUBOTA Dealer for instructions.

■ Fuel Gauge

When the key switch is "ON", the fuel gauge moves to empty once and indicates the fuel level.

It's for the check if the gauge is working.

Be careful not to empty the fuel tank. Otherwise air may enter the fuel system.

Should this happen, the system should be bled (See "Bleeding Fuel System" in "SERVICE AS REQUIRED" Section)

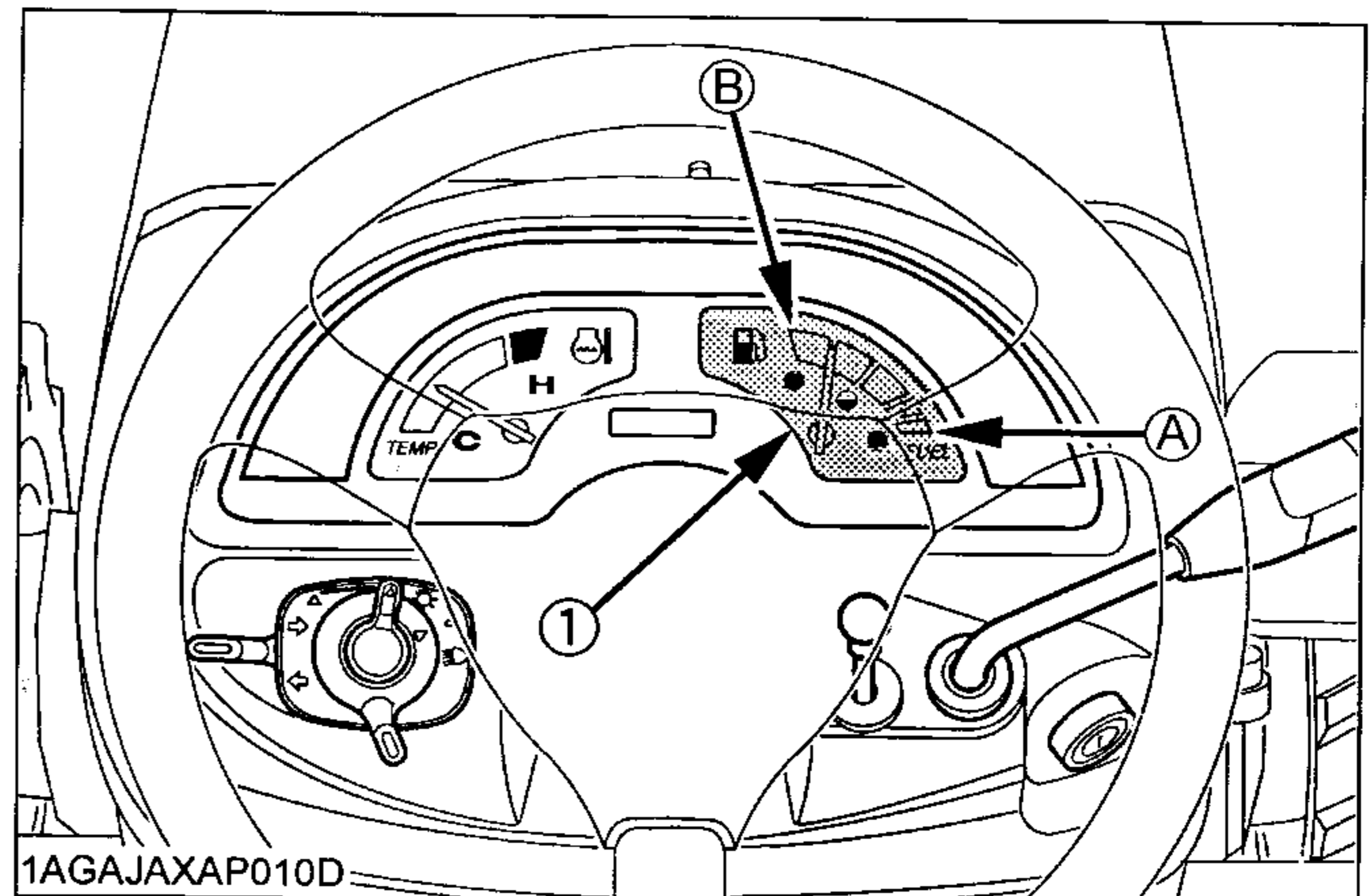

- (1) Fuel gauge
 (A) "EMPTY"
 (B) "FULL"

■ Coolant Temperature Gauge



CAUTION

To avoid personal injury:

- Do not remove radiator cap until coolant temperature is well below its boiling point. Then loosen cap slightly to the stop to relieve any pressure before removing cap completely.

If the indicator reaches red zone,

1. Place the PTO clutch lever in "OFF" (DISENGAGE) position.
2. Move the machine to the level surface, and apply the parking brake.
3. Place the throttle lever in the engine idle position, and let the engine run for a few minutes.
4. Check the Cooling System, after it has sufficient time to cool down.

Check the following items:

1. Shortage or leakage of the coolant.
2. Foreign matter on the radiator net or dust and dirt between the radiator fins.
3. Looseness of fan belt.
4. Blockage in the radiator tube.
 (See "PERIODIC SERVICE" section.)

PARKING

■ Parking



CAUTION

To avoid personal injury:

- Always set the parking brake, stop the engine and remove the key before leaving the tractor seat.

1. When parking, be sure to set the parking brake.
To set the parking brake;
 - (1) Depress the brake pedal.
 - (2) Latch the brake pedal with the parking brake lock pedal.

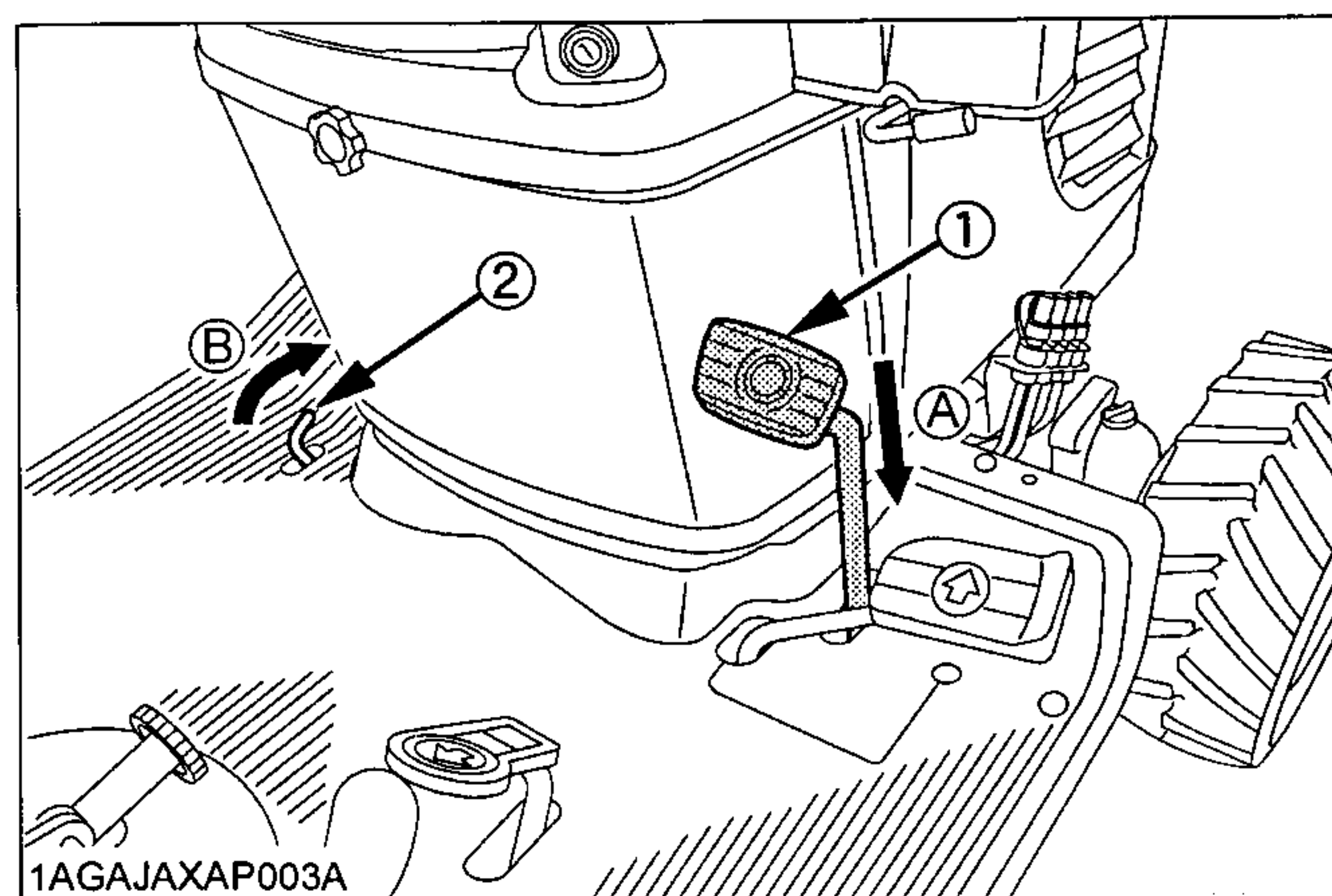

- (1) Brake pedal (A) "DEPRESS"
 (2) Parking brake lock pedal (B) "PUSH FORWARD WHILE DEPRESSING (1)"

2. Before getting off the tractor, disengage the PTO, lower all implements to the ground, place all control levers in their "NEUTRAL" positions, set the parking brake, stop the engine and remove the key.
3. If it is necessary to park on an incline, be sure to chock the wheels to prevent accidental rolling of the machine.

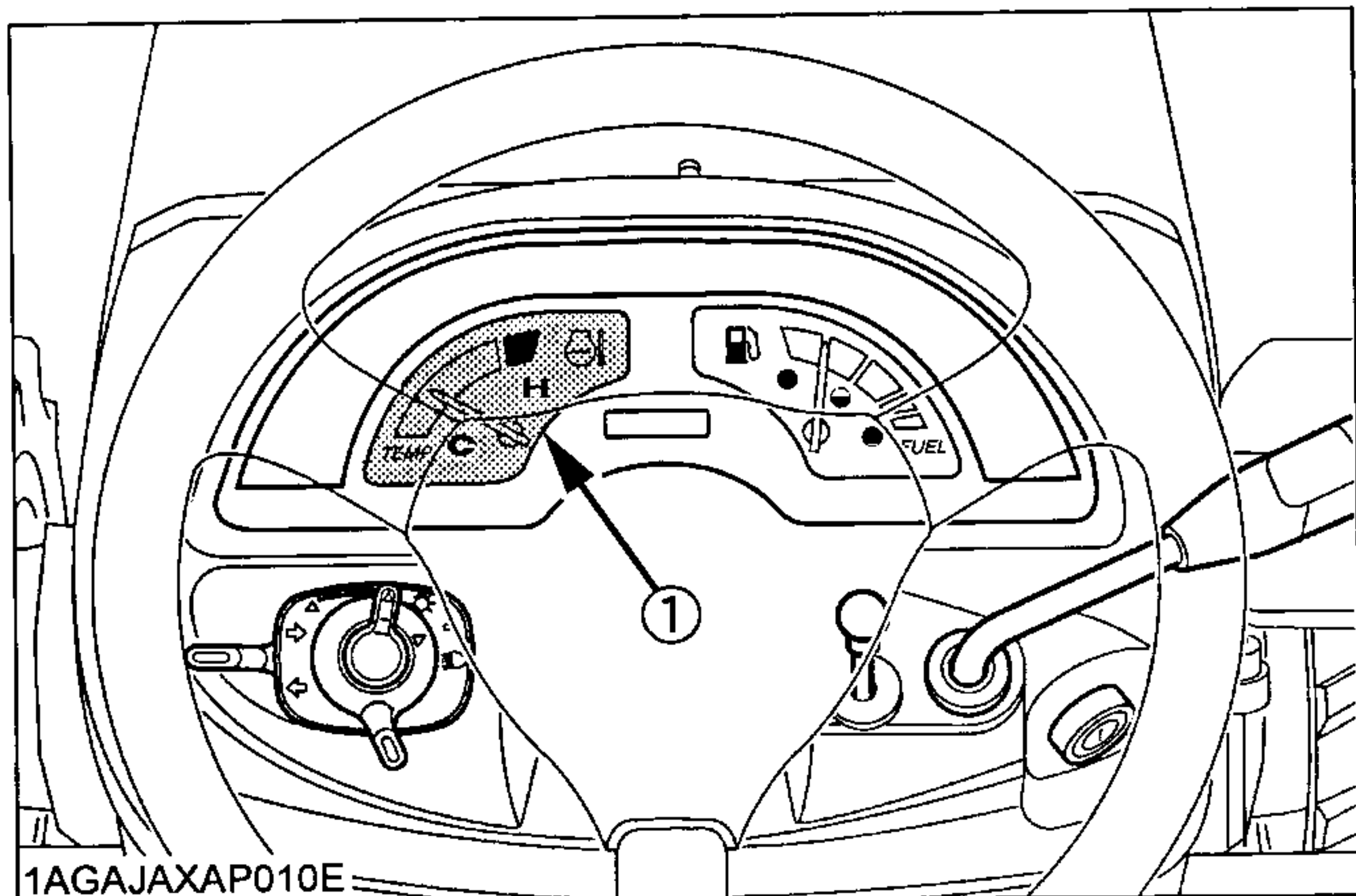

(1) Coolant temperature gauge

■ Hourmeter/Tachometer

When the key switch is "ON" and the engine is "OFF", the indicator displays an hourmeter.

The hourmeter indicates in six digits the hours the tractor has been used; the last digit indicates 1/10 of an hour.

When the key switch is "ON" and the engine is "ON", the indicator displays a tachometer.

The tachometer indicates the engine revolution per minute.

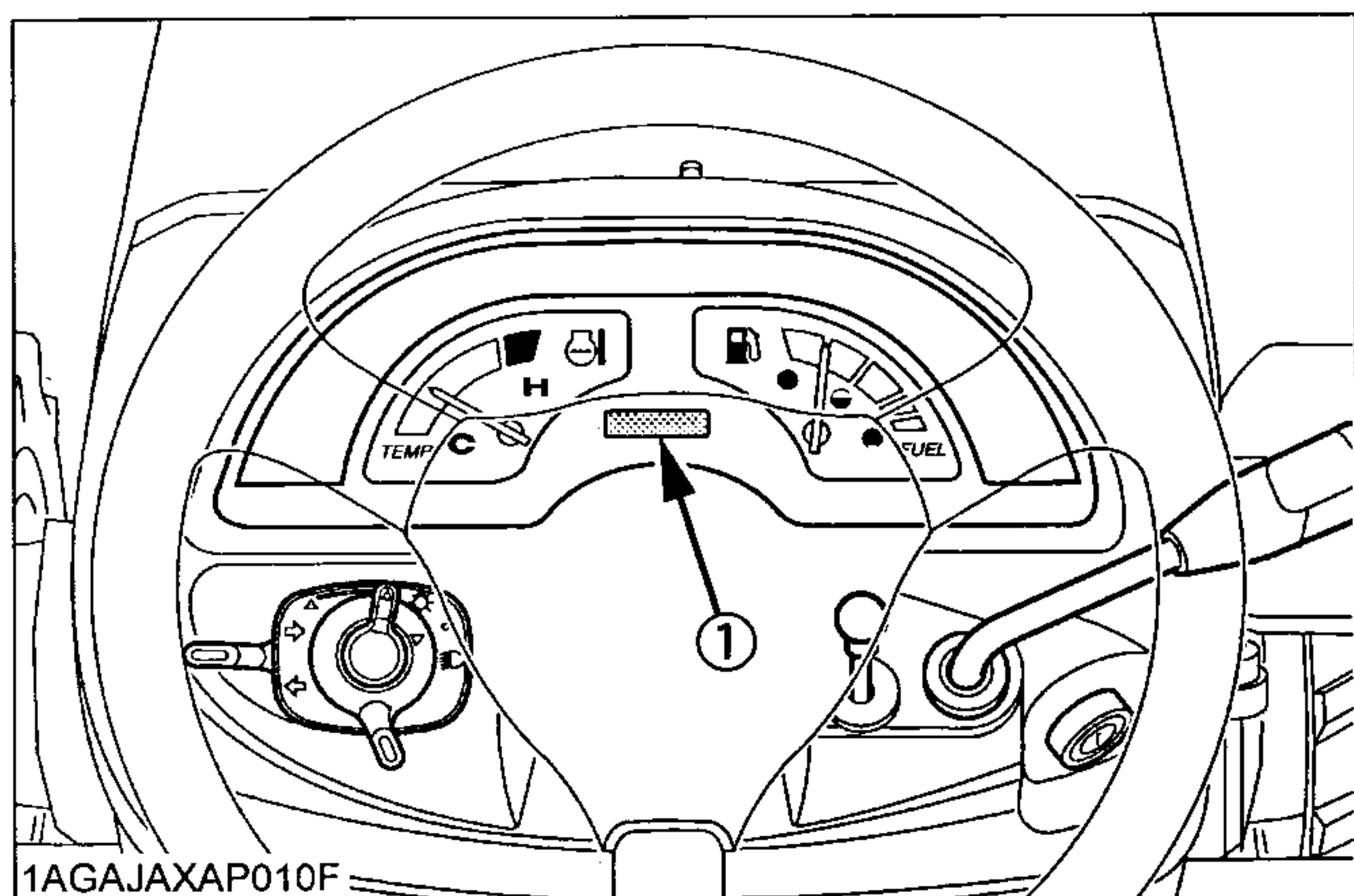

(1) Hourmeter / Tachometer

ACCESSORY

■ 12V Electric Outlet

An auxiliary light or other devices may be connected to this connector.

- ◆ Do not connect a light or other device that draws more than 120 watts to this connector, or the battery may discharge very rapidly or the outlet may fail.

IMPORTANT :

- Do not use as a cigarette lighter.
- Do not use when wet.

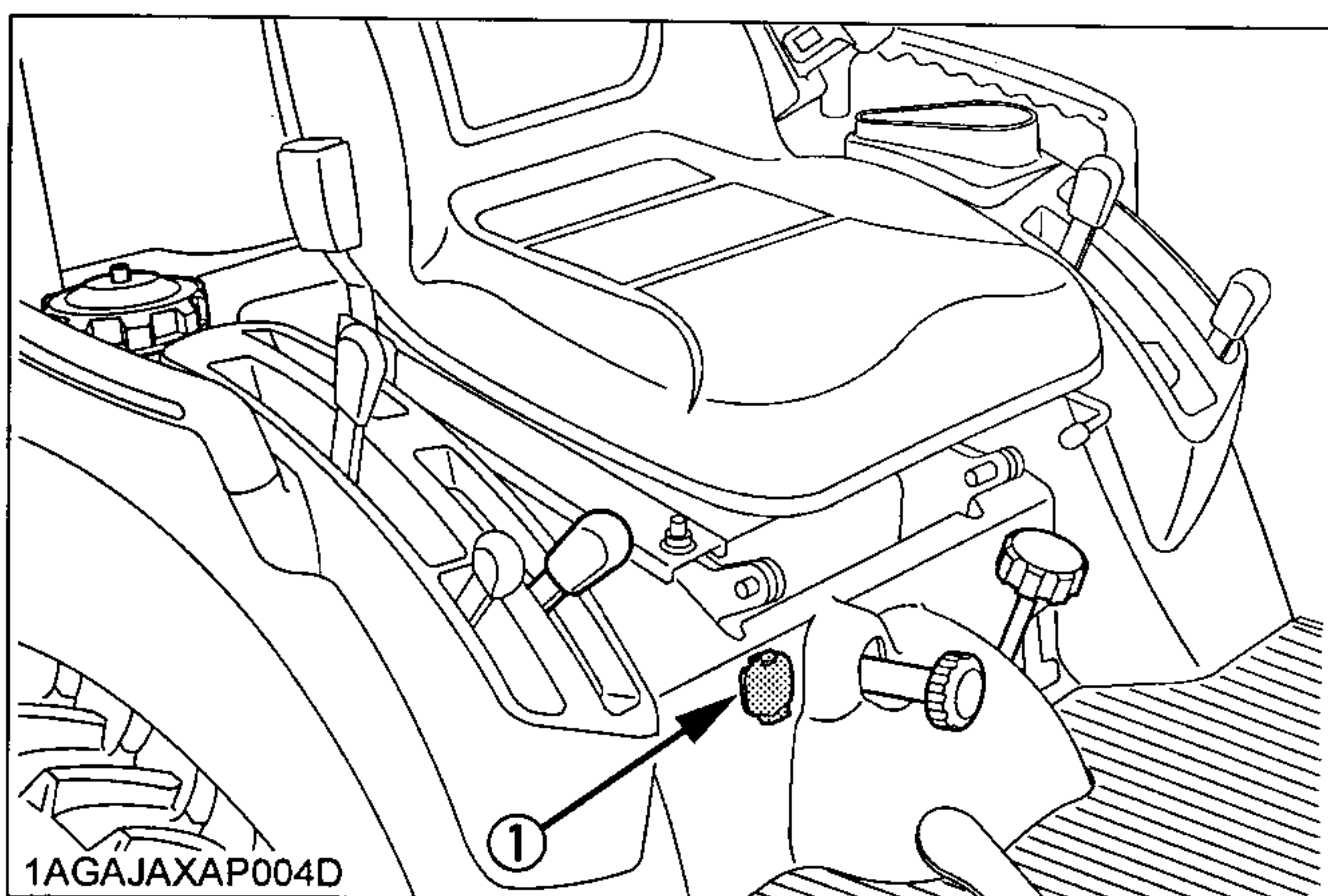

(1) 12V electric outlet

■ Operator's Manual Holder

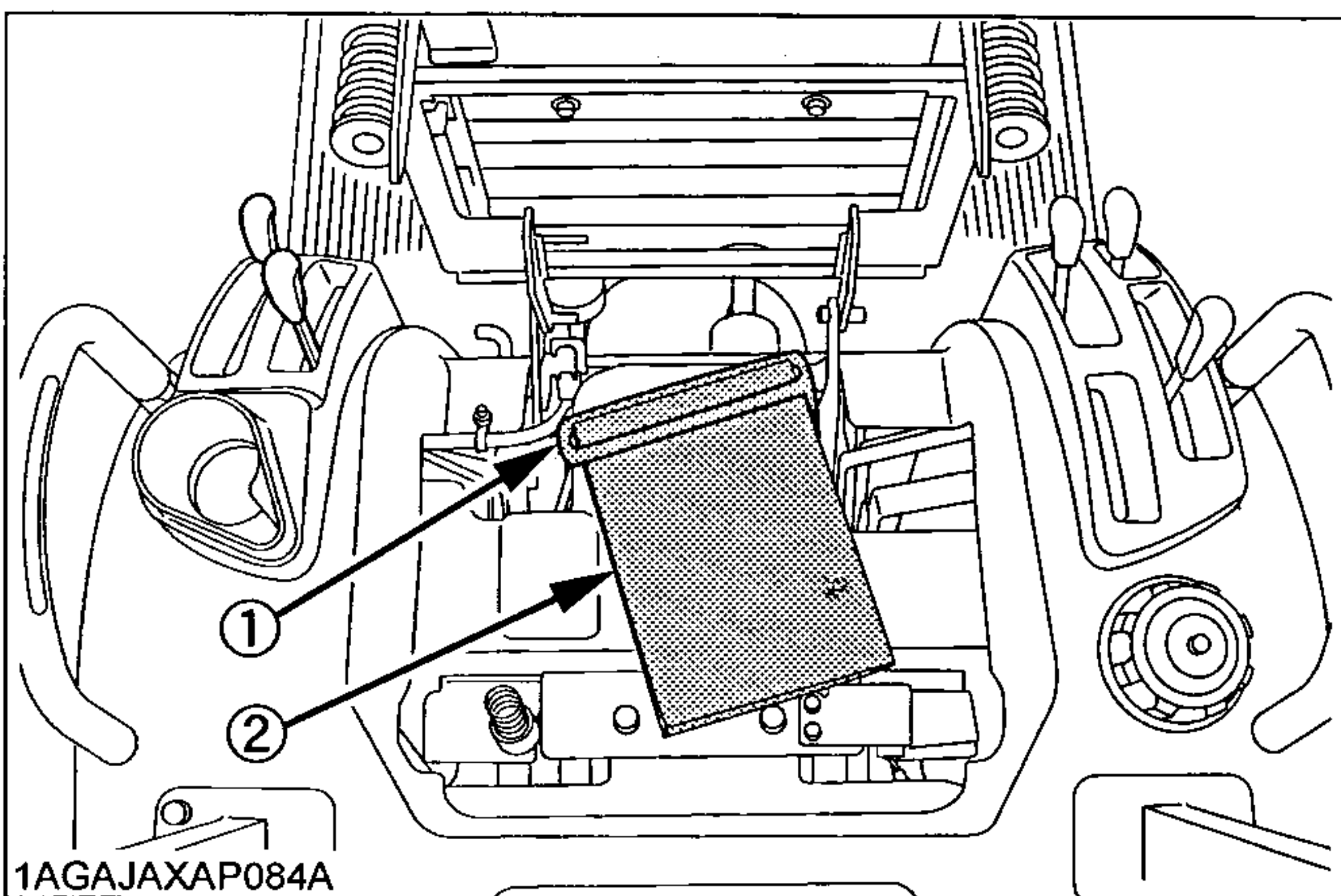

(1) Holder
(2) Bag

OPERATING TECHNIQUES

■ Differential Lock



WARNING

To avoid personal injury due to loss of steering control:

- Do not operate the tractor at high speed with differential lock engaged.
- Do not attempt to turn with the differential lock engaged.
- Be sure to release the differential lock before making a turn in field conditions.

If one of the rear wheels should slip, step on the differential lock pedal. Both wheels will then turn together, reducing slippage.

Differential lock is maintained only while the pedal is depressed.

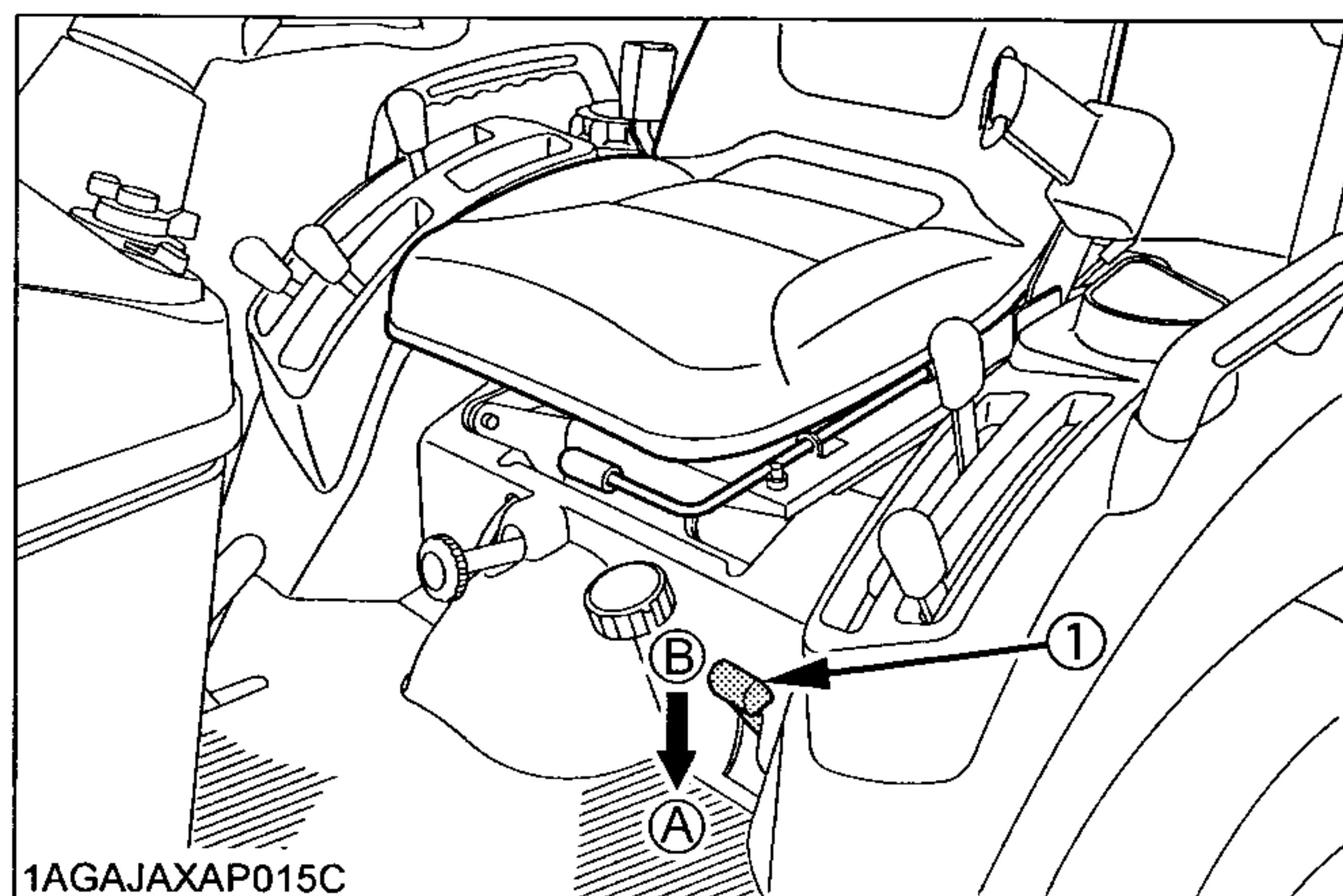

(1) Differential lock pedal
(A) Press to "ENGAGE"
(B) Release to "DISENGAGE"

IMPORTANT :

- When using the differential lock, always slow the engine down.
- To prevent damage to power train, do not engage differential lock when one wheel is spinning and the other is completely stopped.
- If the differential lock cannot be released in the above manner, alternately press speed control pedal forward and backward slightly.

■ Operating the Tractor on a Road

⚠ CAUTION

To avoid personal injury:

- When traveling on road with 3-point hitch mounted implement attached, be sure to have sufficient front weight on the tractor to maintain steering ability.

Be sure SMV emblem and warning lamps are clean and visible. If towed or rear-mounted equipment obstructs these safety devices, install SMV emblem and warning lamps on equipment.

Consult your local KUBOTA Dealer for further details.

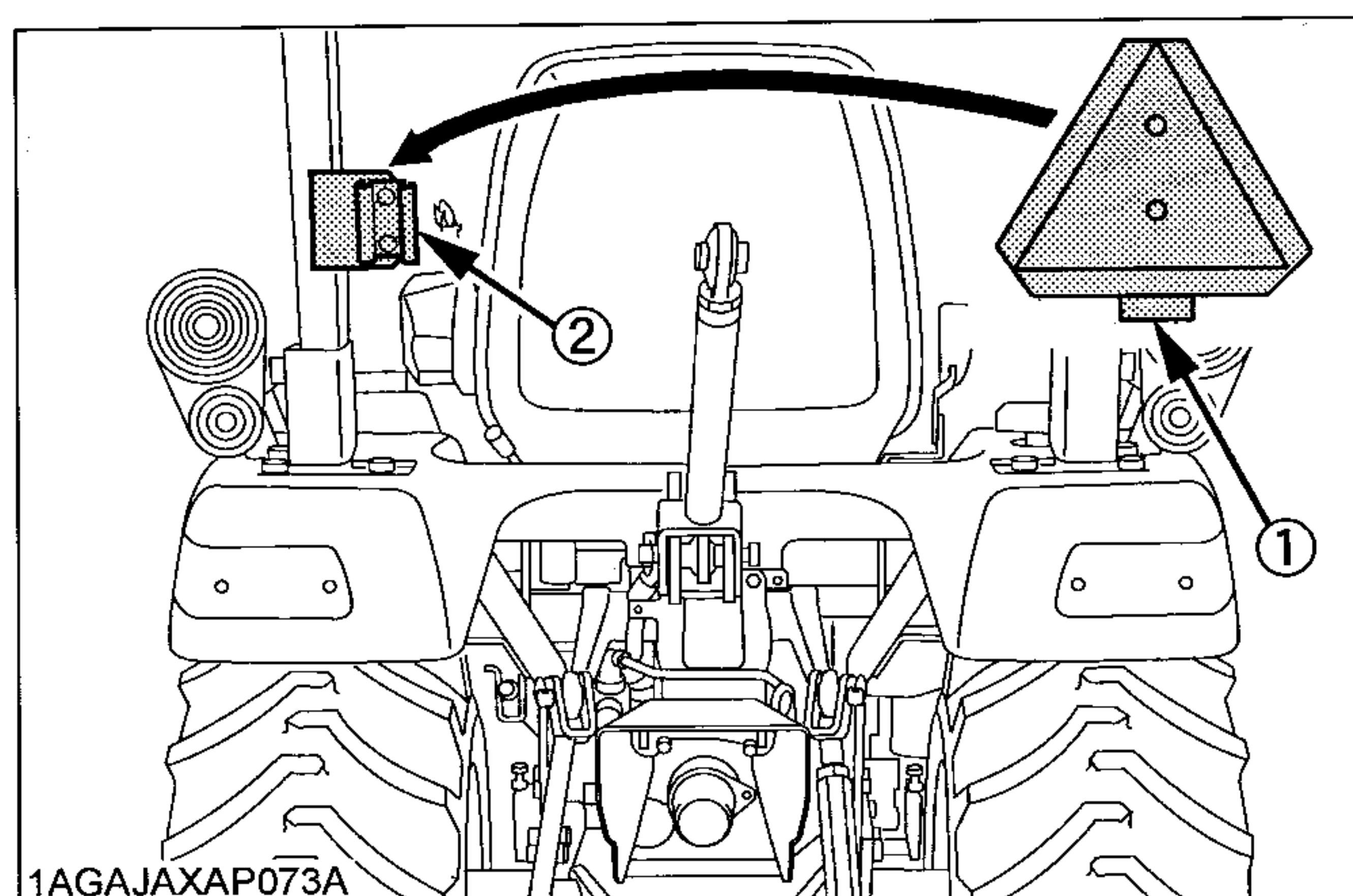

- (1) SMV emblem
(2) Bracket

■ Operating on a Slopes and Rough Terrain

⚠ CAUTION

To avoid personal injury:

- Always back up when going up a steep slope. Driving forward could cause the tractor to tip over backward. Stay off hills and slopes too steep for safe operation.
- Avoid changing gears when climbing or descending a slope.
- If operating on a slope, never disengage shift levers to "NEUTRAL". Doing so could cause machine and loss of control.
- Do not drive the tractor close to the edges of ditches or banks which may collapse under the weight of the tractor. Especially when the ground is loose or wet.

1. Slow down for slopes, rough ground, and sharp turns, especially when transporting heavy, rear mounted equipment.
2. Before descending a slope, be sure that the range lever is in the low "🐢" so that speed can be controlled without using brakes.

■ Directions for Use of Power Steering

1. Power steering is activated only while the engine is running. While the engine is stopped, the tractor functions in the same manner as tractors without power steering.
2. When the steering wheel is turned all the way to the stop, the relief valve is activated. Do not hold the steering wheel in this position for a long period of time.
3. Avoid turning the steering wheel while the tractor is stopped, or tires may wear out sooner.
4. The power steering mechanism makes the steering easier. Be careful when driving on a road at high speeds.

PTO

PTO OPERATION



WARNING

To avoid personal injury:

- Before operation, be sure to select the correct PTO lever (mid, mid/rear, rear).



CAUTION

To avoid personal injury:

- Disengage PTO, stop engine, and allow all rotating components to come to a complete stop before connecting, disconnecting, adjusting, or cleaning any PTO driven equipment.

■ PTO Select Lever

The tractor has a 540 rpm rear PTO speed and a 2500 rpm mid-PTO speed.

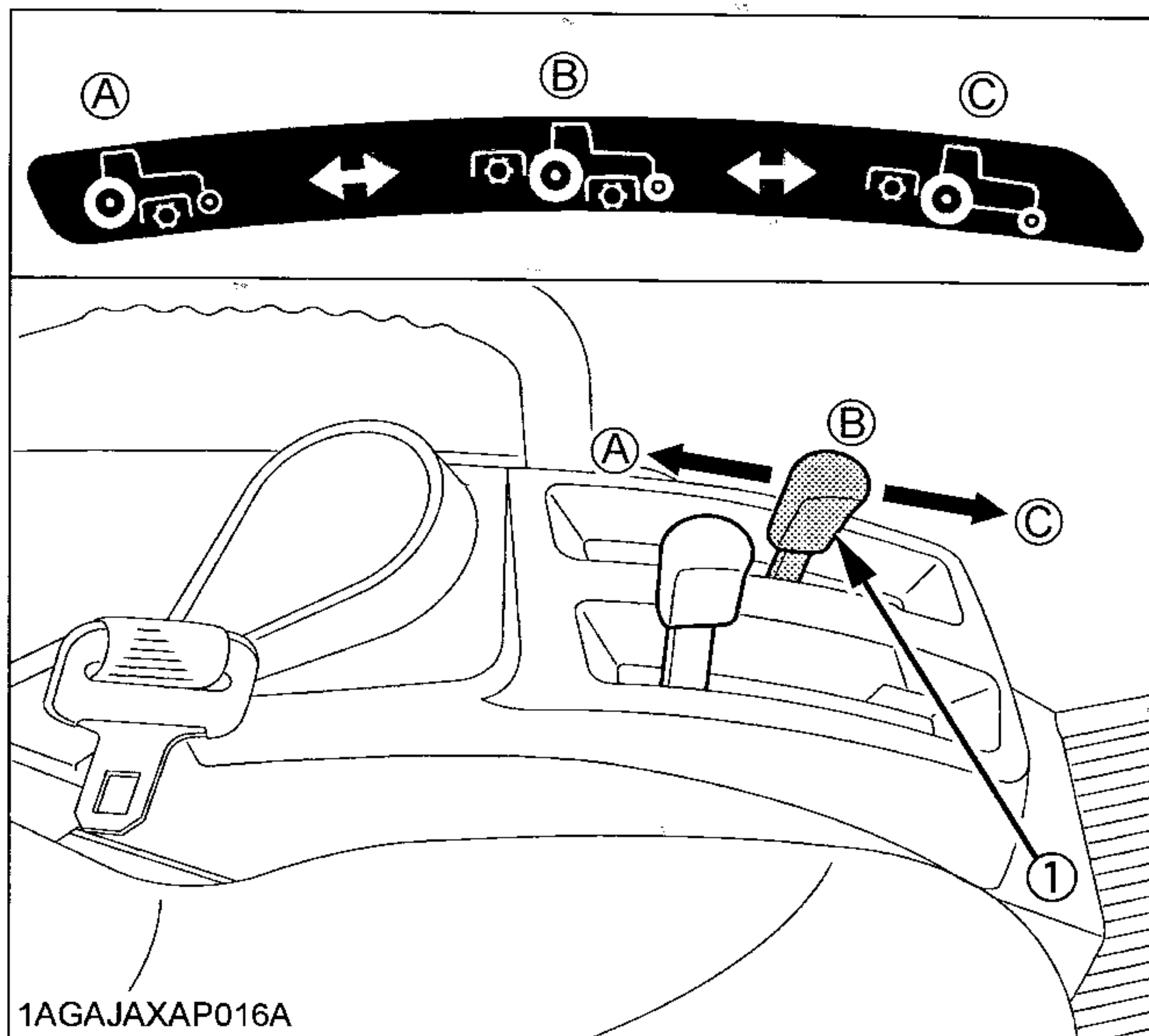

(1) PTO select lever

(A) Mid-PTO position

(B) Mid-Rear-PTO position

(C) Rear-PTO position

◆ Mid-PTO

To use Mid-PTO, shift the PTO select lever to Mid-PTO position and the PTO clutch lever to "ON" position.

◆ Mid-Rear PTO

To use mid and rear PTO at the same time, shift the PTO select lever to mid-rear PTO position and the PTO clutch lever to "ON" position.

◆ Rear PTO

To use rear PTO, shift the PTO select lever to rear PTO position and the PTO clutch lever to "ON" position.

IMPORTANT :

- To avoid shock loads to the PTO, reduce engine throttle from full to half speed by pushing up on engine throttle when engaging the PTO, then open the throttle to the recommended speed.
- To avoid damage of transmission, when PTO select lever is not smoothly shifted, slightly shift PTO clutch lever.

◆ Mid-PTO

The Mid-PTO is available for KUBOTA approved implements.

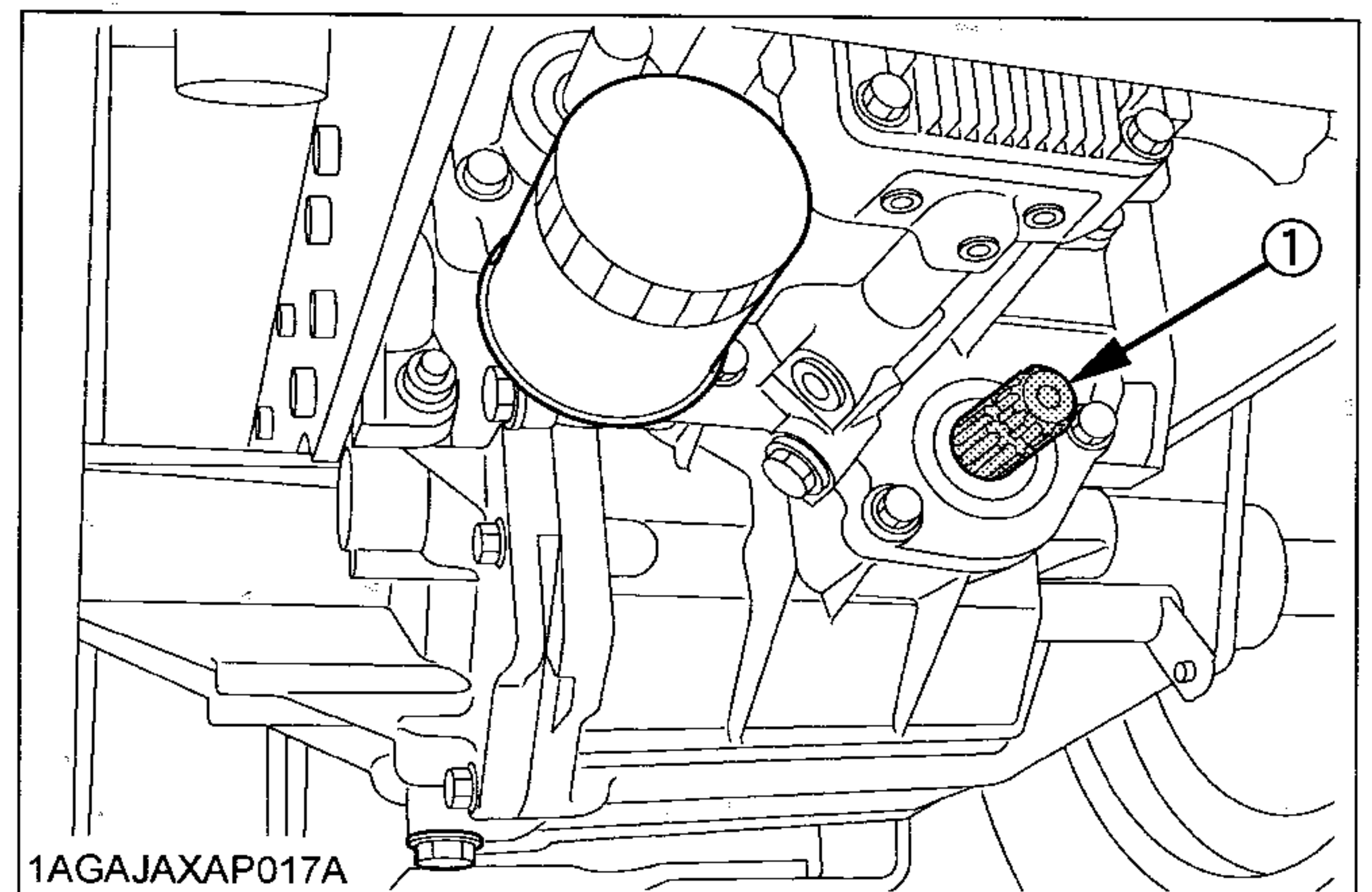

(1) Mid-PTO

■ PTO Clutch Lever

1. The PTO clutch lever engages or disengages the PTO clutch which gives the PTO independent control.
2. Shift the lever to "ON" to engage the PTO clutch. Shift the lever to "OFF" to disengage the PTO clutch.

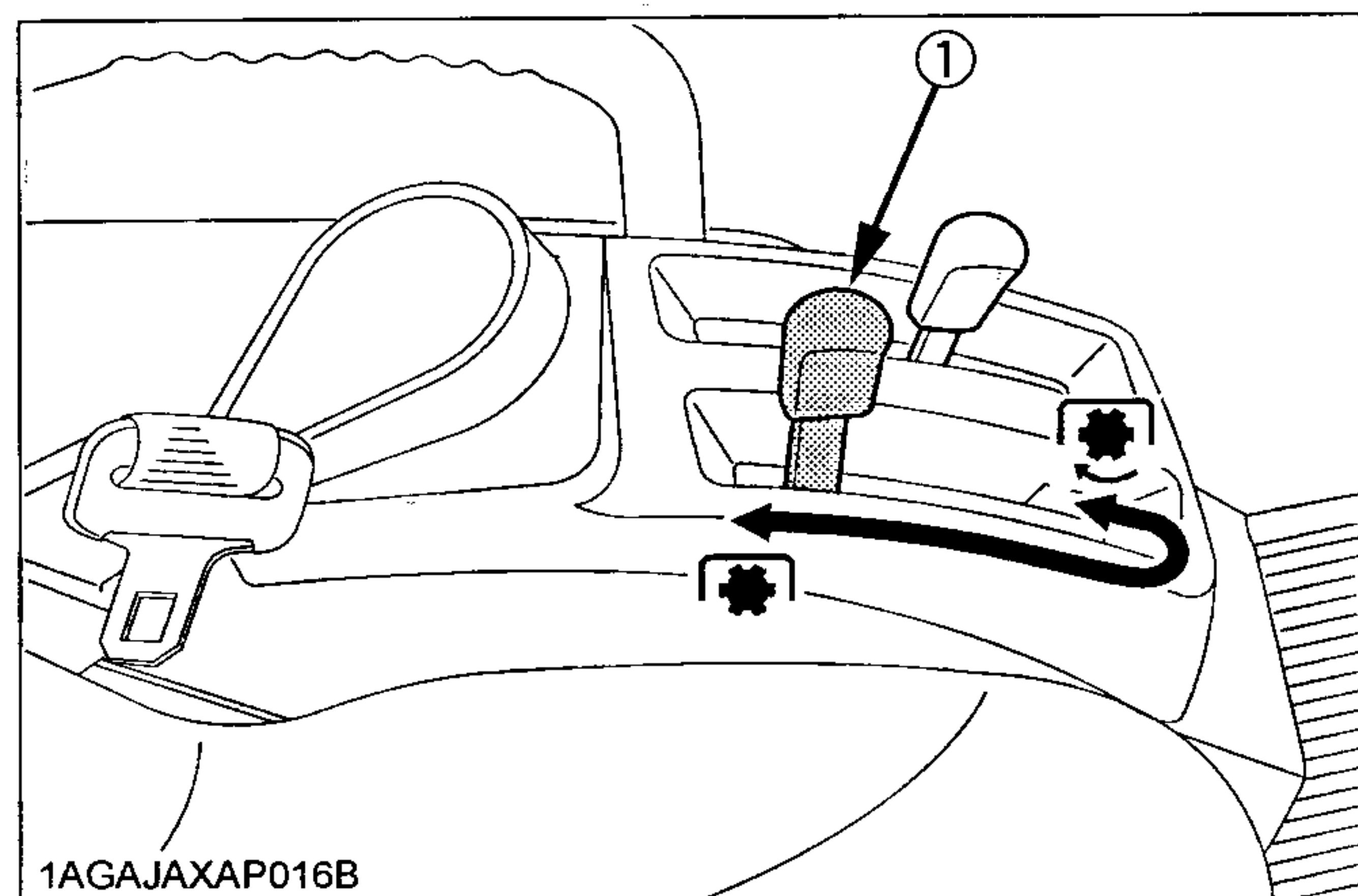

1AGA JAXAP016B

(1) PTO clutch lever

"ON" "ENGAGE"

"OFF" "DISENGAGE"

IMPORTANT :

- To avoid shock loads to the PTO, reduce engine throttle from full to half speed by pushing up on engine throttle when engaging the PTO, then re-engage the engine to full.
- To avoid damage to PTO clutch and implement, shift the PTO clutch lever slowly, when engaging the PTO clutch. Do not keep the PTO clutch lever half way.

NOTE :

- Tractor engine will not start if the PTO clutch lever is in the engaged "ON" position.
- When you stand up from the seat with the PTO clutch lever at "ON" position, the engine will stop regardless of the position of the PTO select lever. This is because the tractor is equipped with Operator Presence Control system (OPC).

■ PTO Shaft Cover and Shaft Cap

Keep the PTO shaft cover in place at all times. Replace the PTO shaft cap when the PTO is not in use. Before connecting or disconnecting a drive shaft to PTO shaft, be sure engine is "OFF" and raise up the PTO shaft cover. Afterward be sure to return the PTO shaft cover to "NORMAL POSITION".

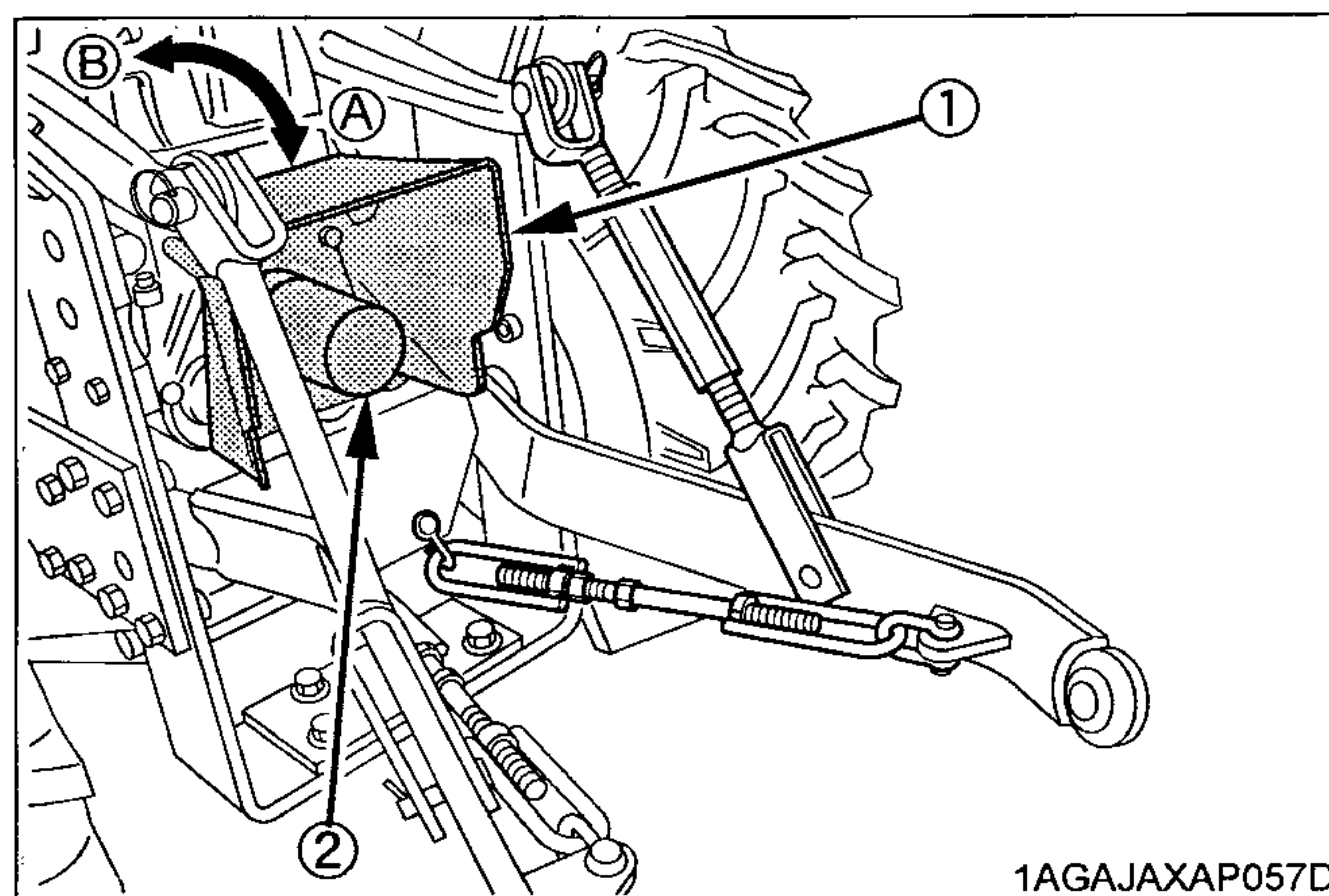

1AGA JAXAP057D

(1) PTO shaft cover

(2) PTO shaft cap

(A) "NORMAL POSITION"

(B) "RAISED POSITION"

Stationary PTO

To park the tractor and use the PTO system (for chipper or pump, for example), start the PTO system in the following steps.

1. Apply the parking brakes and place blocks at the tires.
2. Make sure all shift levers are at "NEUTRAL", and start the engine.
3. Set the PTO select lever to rear only position.
4. Dismount the seat and tilt up.
5. Move the lever behind the seat frame the arrow direction to release the seat lock, and tilt the seat forward.

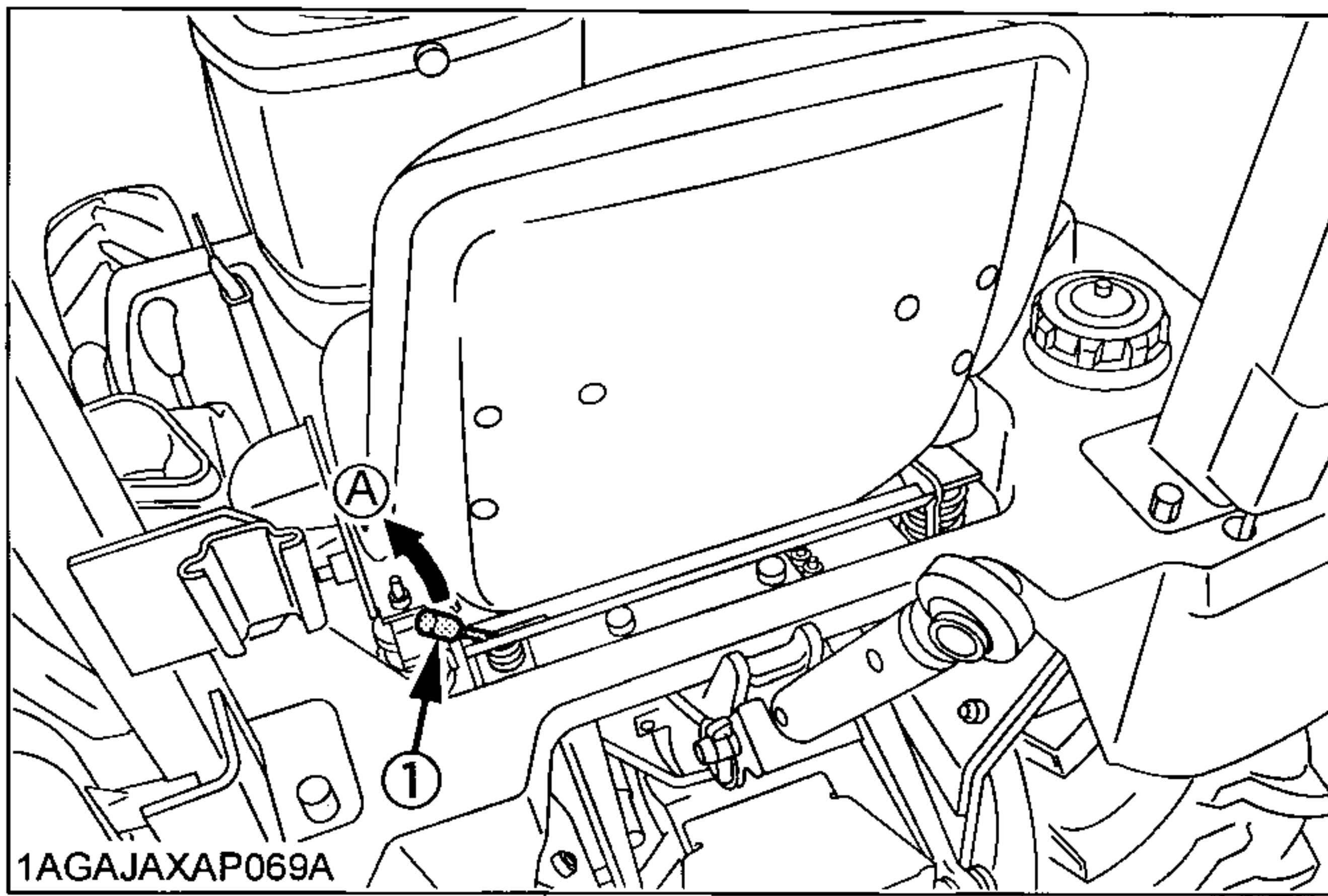

(1) Seat lock lever (A) "UNLOCK"

6. Set the PTO clutch lever to engage "ON".
7. Set the engine speed to provide recommended rear PTO speed.

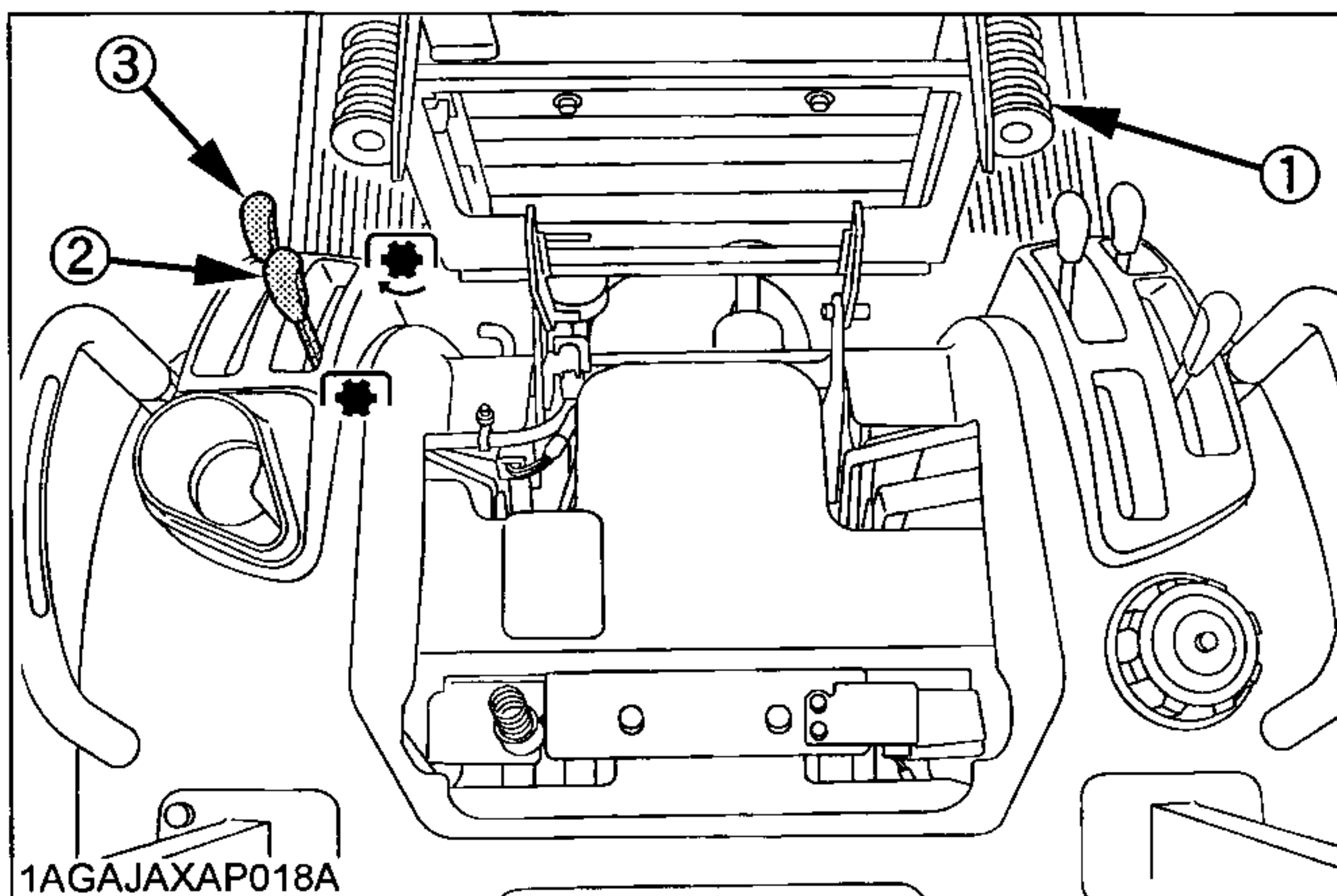

(1) Seat
 (2) PTO clutch lever
 (3) PTO select lever
 [ON symbol] "ON"
 [OFF symbol] "OFF"

NOTE :

- If the PTO clutch lever is shifted to "ON" (Engaged) position under the following condition, the engine will stop itself.
 - (1) The speed control pedal is not at "NEUTRAL" position.

- (2) The PTO select lever is not at "REAR PTO" position.
- (3) The seat is not tilted forward.

PTO Drive Shaft

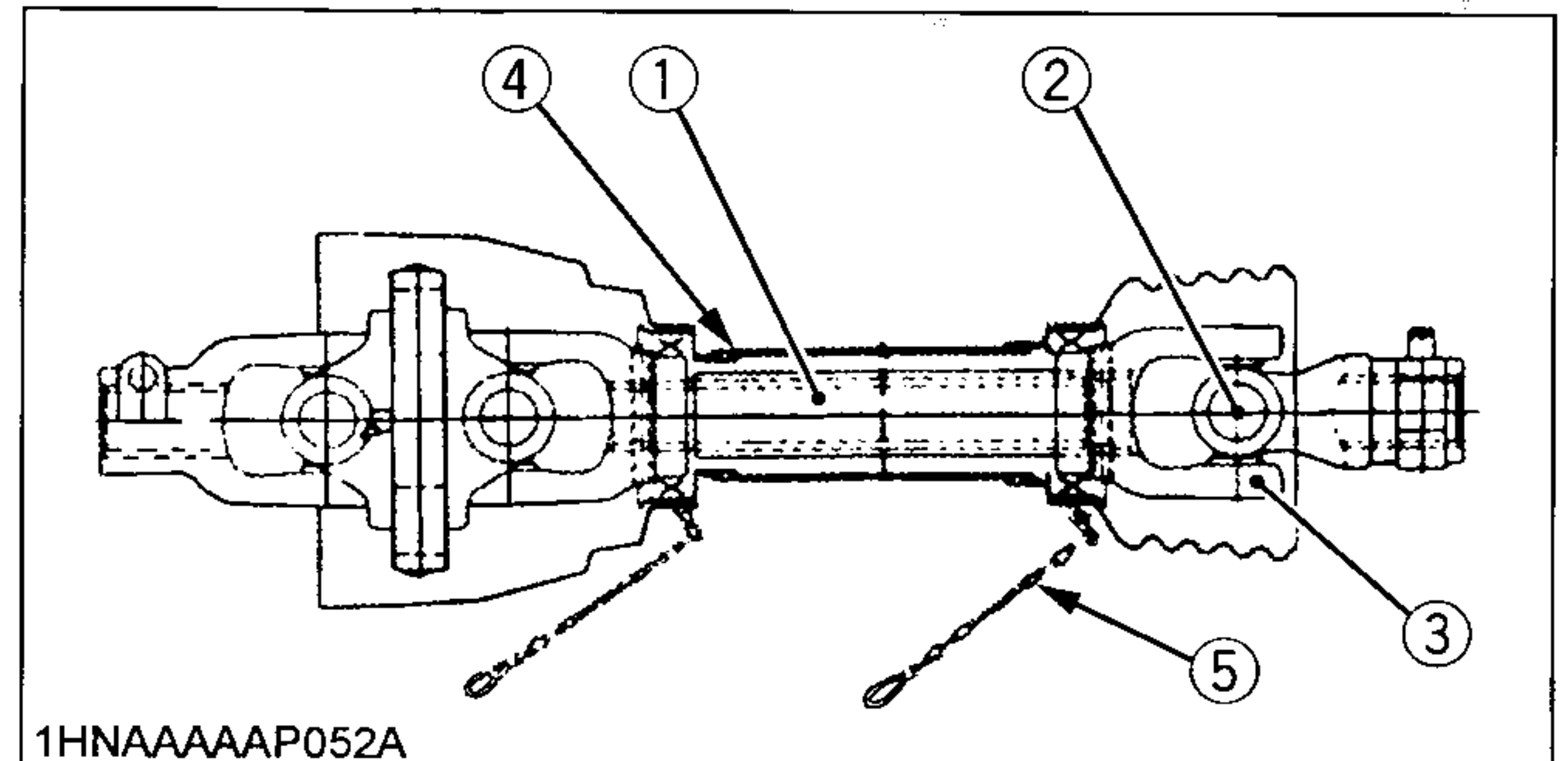

(1) Inner and outer sliding profile tubes
 (2) Journal cross assy
 (3) Fitting yoke
 (4) Safety guard (In, Out)
 (5) Chain

1. When using a PTO drive shaft, read the operator's manual of the implement before operating the implement.
 PTO drive shafts are designed for specific machines and power requirement.
2. To adjust the length of the PTO drive shaft, refer to the following instructions.
 - (1) To adjust the length, hold the half shafts next to each other in the shortest working position and mark them.
 - (2) Shorten inner and outer guard tubes equally.
 - (3) Shorten inner and outer sliding profiles tube by the same length as the guard tubes.
 - (4) Round off all sharp edges and remove burrs.
 Grease sliding profiles.

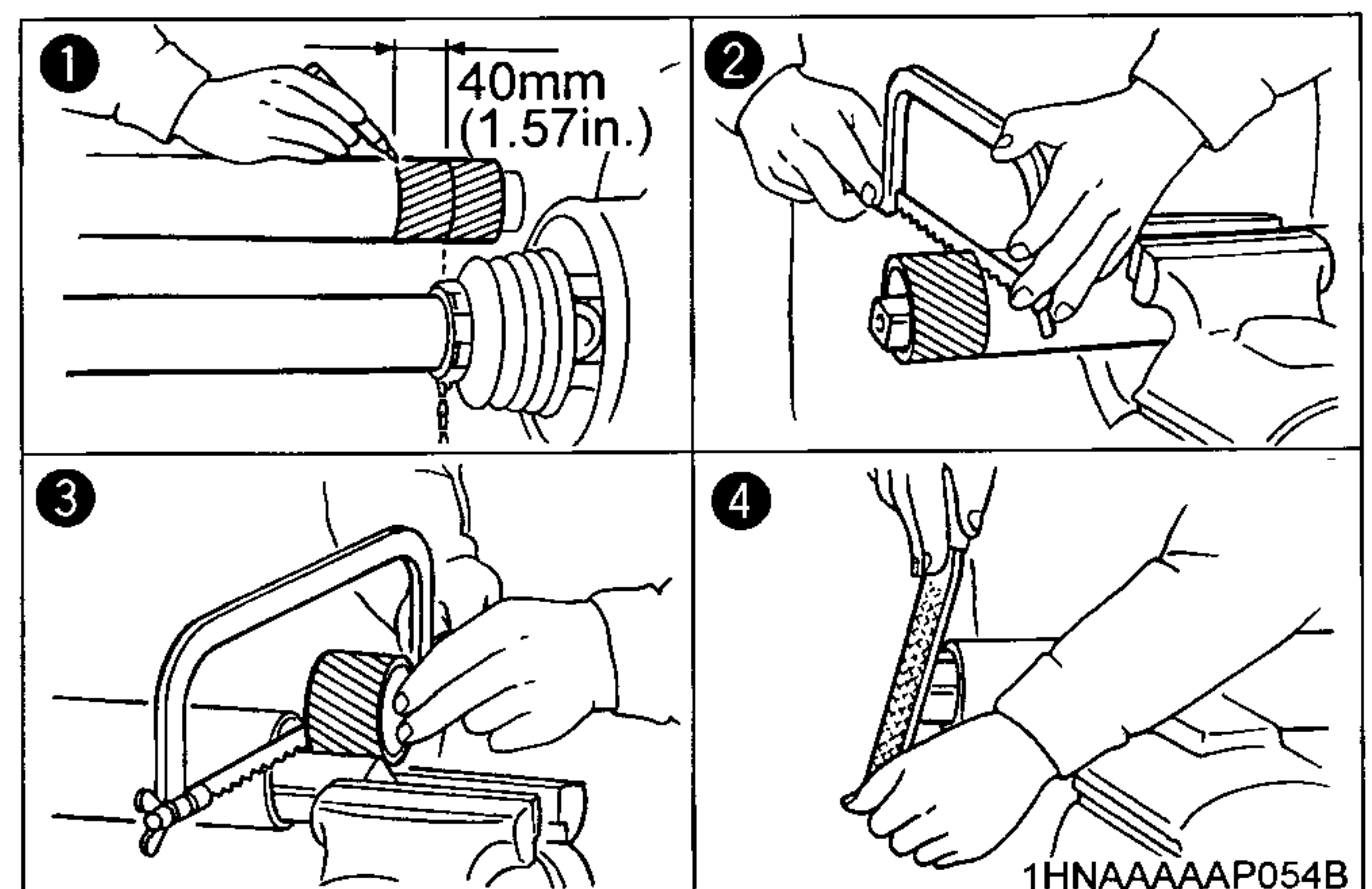

3. Ensure that the PTO drive shaft is securely connected at both ends before operating.

THREE-POINT HITCH & DRAWBAR

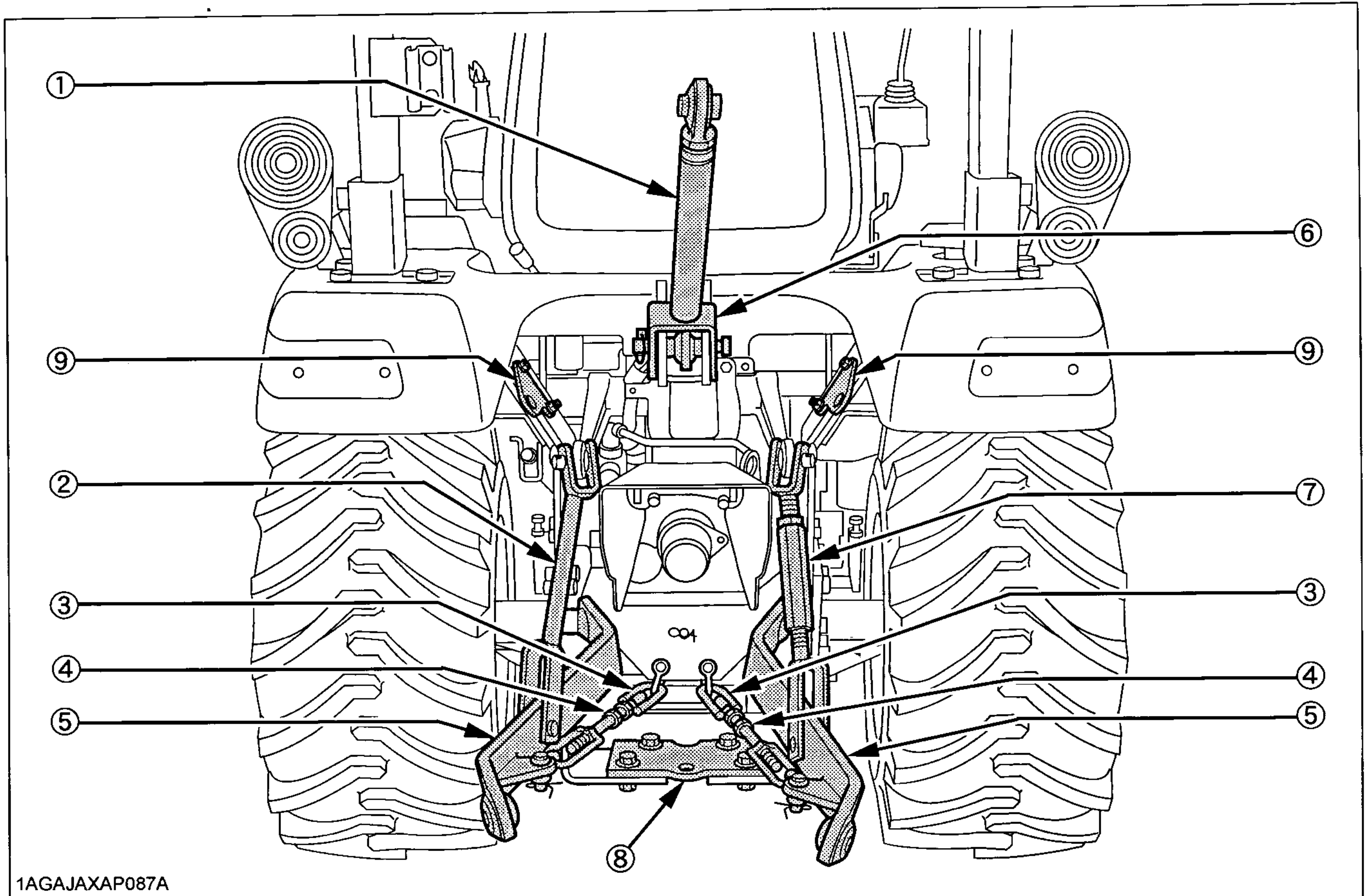

1AGAJAXAP087A

Use holder plate to hold lower link higher while mowing with mid-mount mower only over uneven terrain.

- (1) Top link
- (2) Lifting rod (Left)
- (3) Check chains
- (4) Turnbuckle
- (5) Lower link
- (6) Top link holder
- (7) Lifting rod (Right)
- (8) Drawbar
- (9) Holder plate

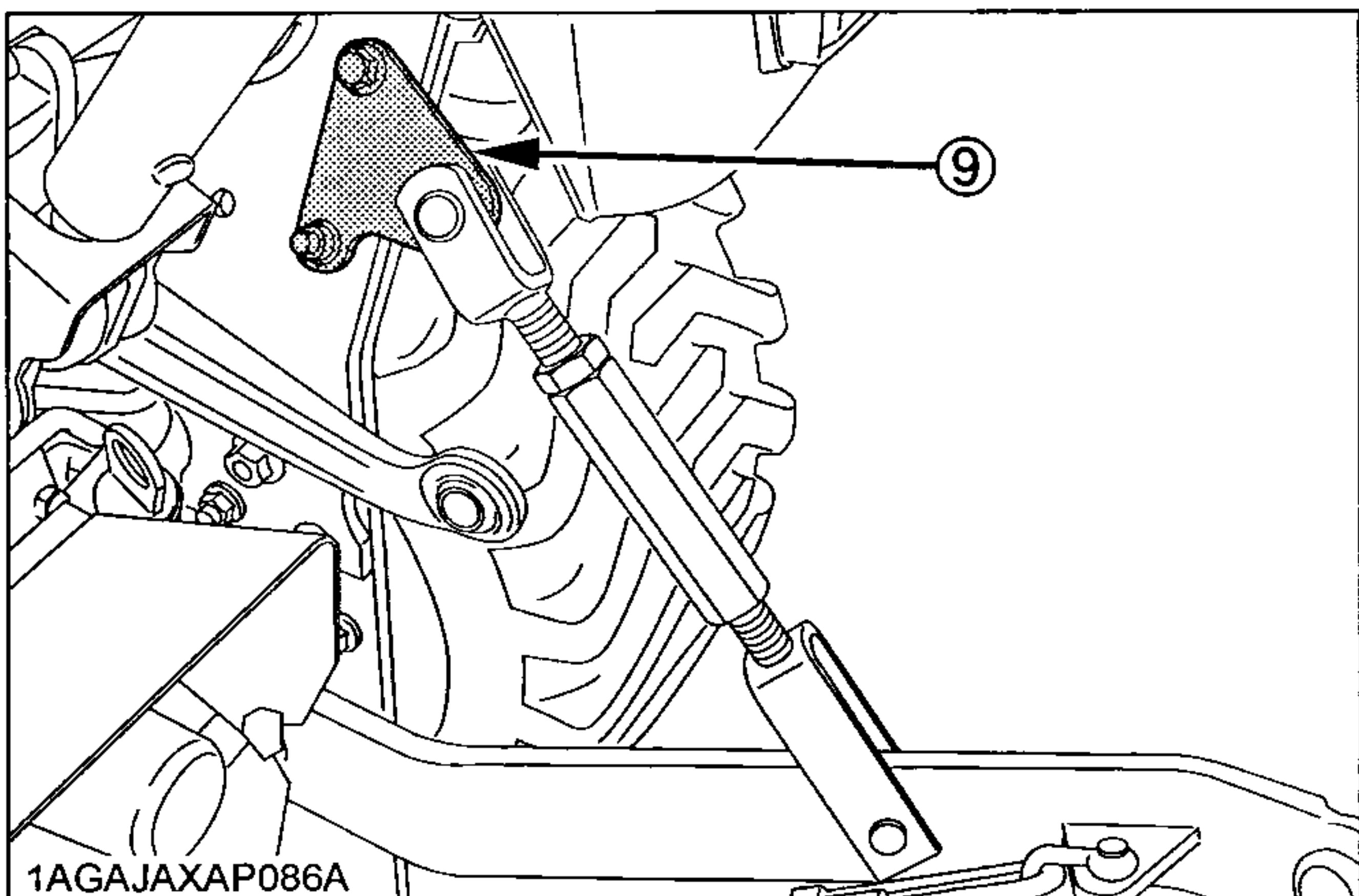

1AGAJAXAP086A

(9) Holder plate

3-POINT HITCH

■ Attaching and detaching implements

CAUTION

To avoid personal injury:

- Be sure to stop the engine and remove the key.
- Do not stand between tractor and implement unless parking brake is applied.
- Before attaching or detaching implement, locate the tractor and implement on a firm, flat and level surface.
- Whenever an implement or other attachment is connected to the tractor 3-point hitch, slowly move the 3-point hitch through the full range of operation and check for interference, binding or PTO separation before operating the machine.

■ Lifting Rod (Right)

CAUTION

To avoid personal injury from separation:

- Do not extend lift rod beyond the groove on the threaded rod. See the illustration that is on the safety label part K2581-6555-1.

Level a 3-point mounted implement from side to side by turning the adjusting turnbuckle to shorten or lengthen the adjustable lifting rod with the implement on the ground. After adjustment, tighten the lock nut securely.

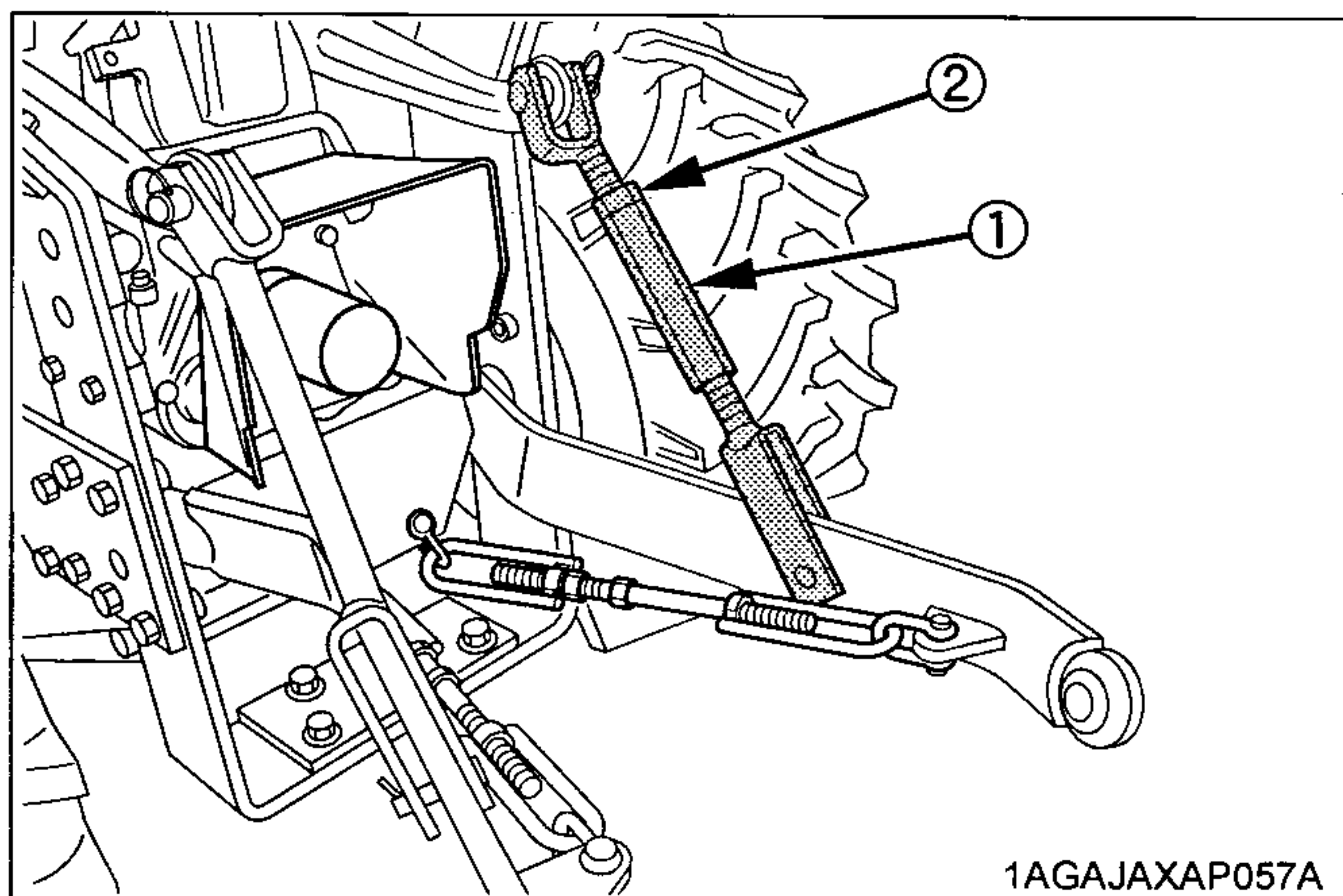

(1) Adjusting turnbuckle
(2) Lock nut

■ Top Link

1. Adjust the angle of the implement to the desired position by shortening or lengthening the top link.
2. The proper length of the top link varies according to the type of implement being used.

NOTE :

- When not using the top link, make it the shortest length and fix it to the top link holder.

■ Check Chains

Adjust the turnbuckle to control horizontal sway of the implement.

After adjustment, retighten the lock nut.

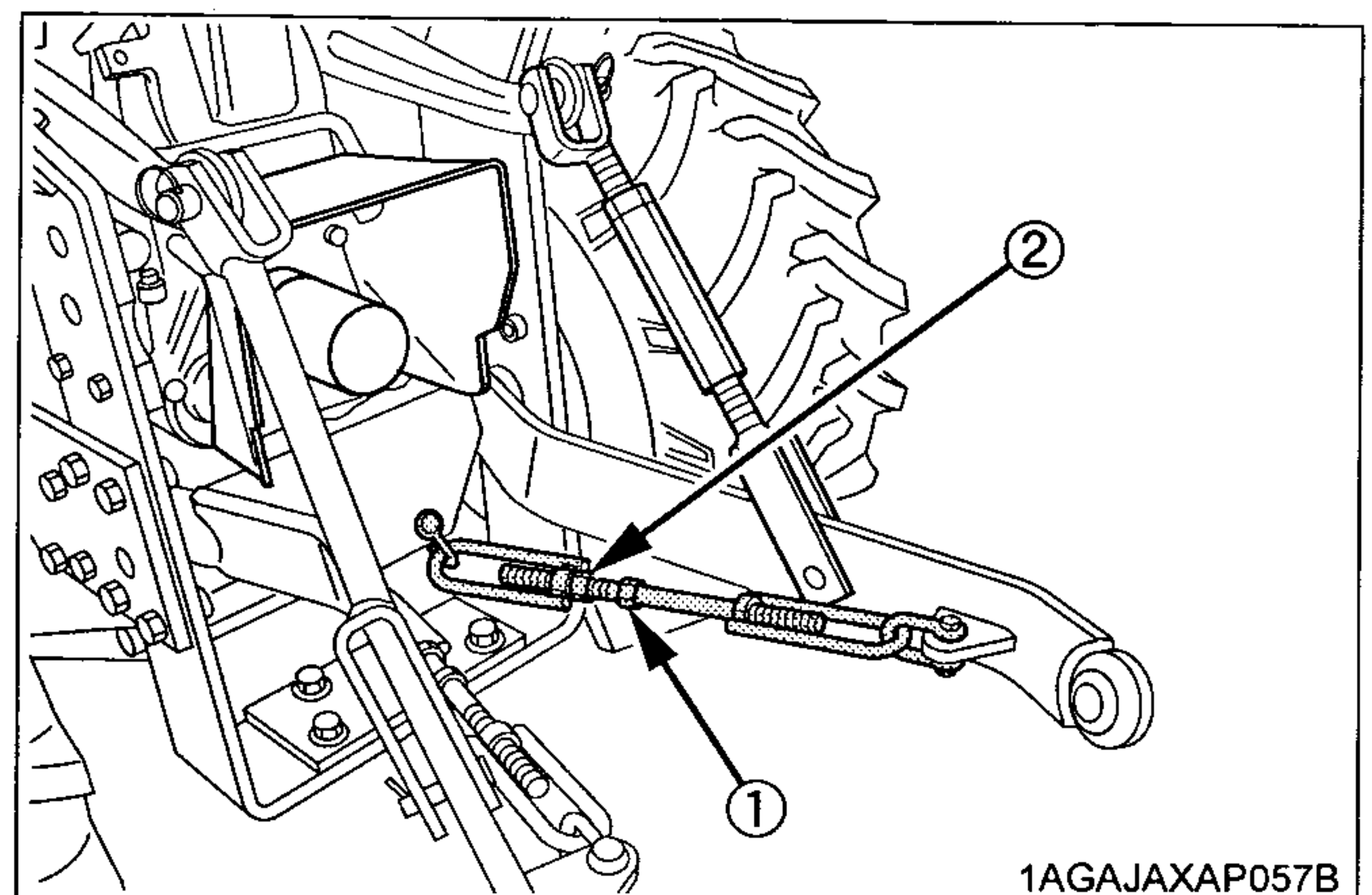

(1) Turnbuckle
(2) Lock nut

HITCH

WARNING

To avoid personal injury:

- Never pull from the top link, the rear axle or any point above the hitch. Doing so could cause the tractor to tip over rearward causing personal injury or death.

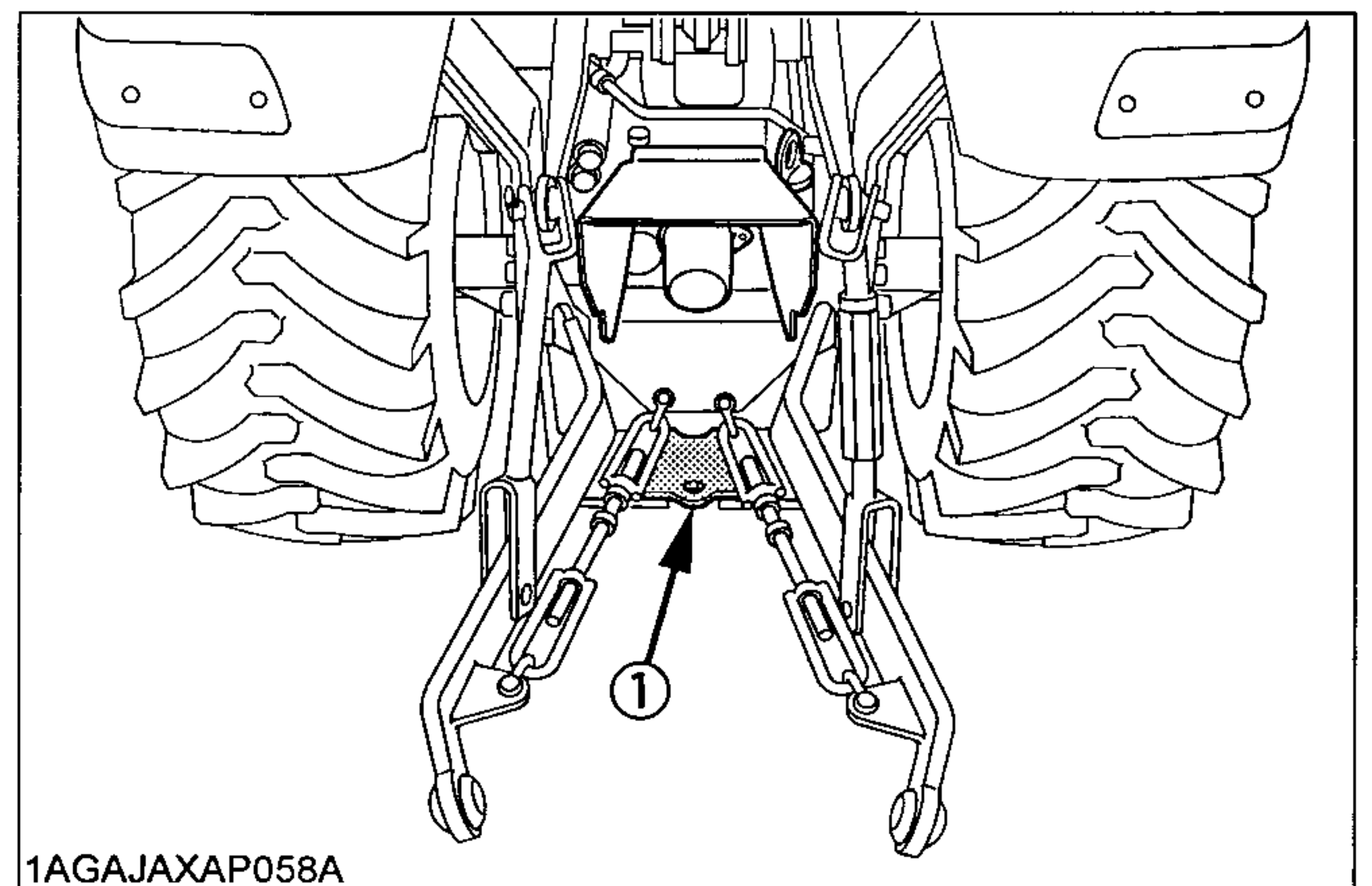

(1) Hitch

HYDRAULIC UNIT

3-POINT HITCH CONTROL SYSTEM

Hydraulic Control

Operating the hydraulic control lever actuates the hydraulic lift arm, which controls the elevation of 3-point hitch mounted implement.

To lower implement, move the hydraulic control lever forward; to raise it, move the hydraulic control lever rearward.

The positions (B) and (C) of the lever in contact with the inner stopper enables you to control the valve with ease in increments of approximately 6.4 mm (0.25 in.) at the lower link end.

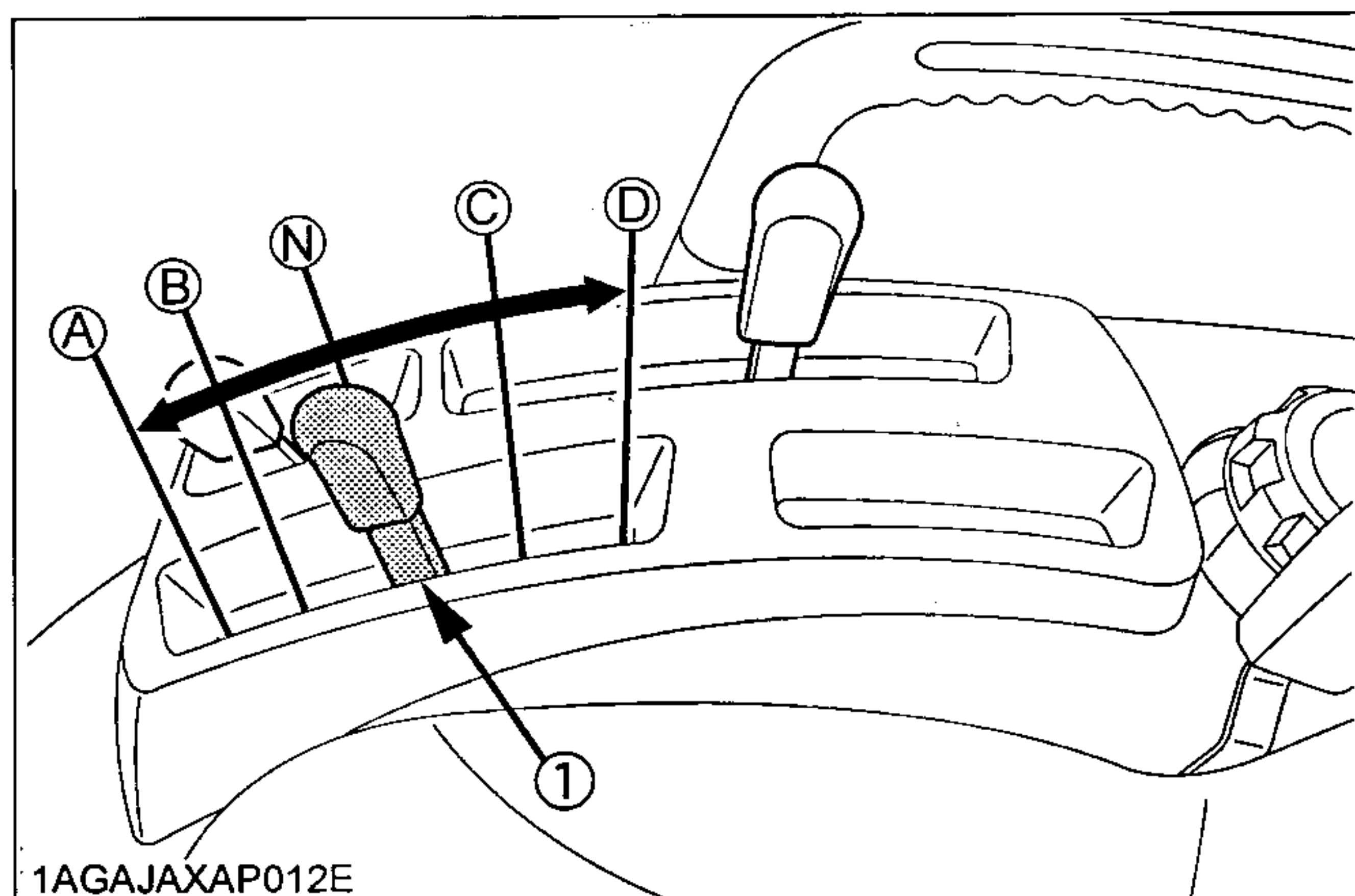

(1) Hydraulic control lever

- (A) "DOWN"
- (B) "SLOW DOWN"
- (N) "NEUTRAL"
- (C) "SLOW UP"
- (D) "UP"

IMPORTANT :

- If the 3-point hitch can not be raised by setting the hydraulic control lever to the "UP" position after long term storage or when changing the transmission oil, follow these air bleeding procedures.
 - (1) Stop the engine.
 - (2) Set the hydraulic control lever to the down position and start the engine.
 - (3) Operate the engine at low idle speed for at least 30 seconds to bleed air from the system.
- Do not operate until the engine is warmed up. If operation is attempted when the engine is still cold, the hydraulic system may be damaged.
- If noises are heard when implement is lifting after the hydraulic control lever has been activated, the hydraulic mechanism is not adjusted properly. Unless corrected the unit will be damaged. Contact your KUBOTA Dealer for adjustment.

3-point Hitch Lowering Speed



CAUTION

To avoid personal injury:

- Fast lowering speed may cause damage or injury. Lowering speed of implement should be adjusted to two or more seconds.

The lowering speed of the 3-point hitch can be controlled or locked in similar fashion to a water faucet, turn toward (A) to increase (B) to reduce and (C) firmly to the stop for lock.

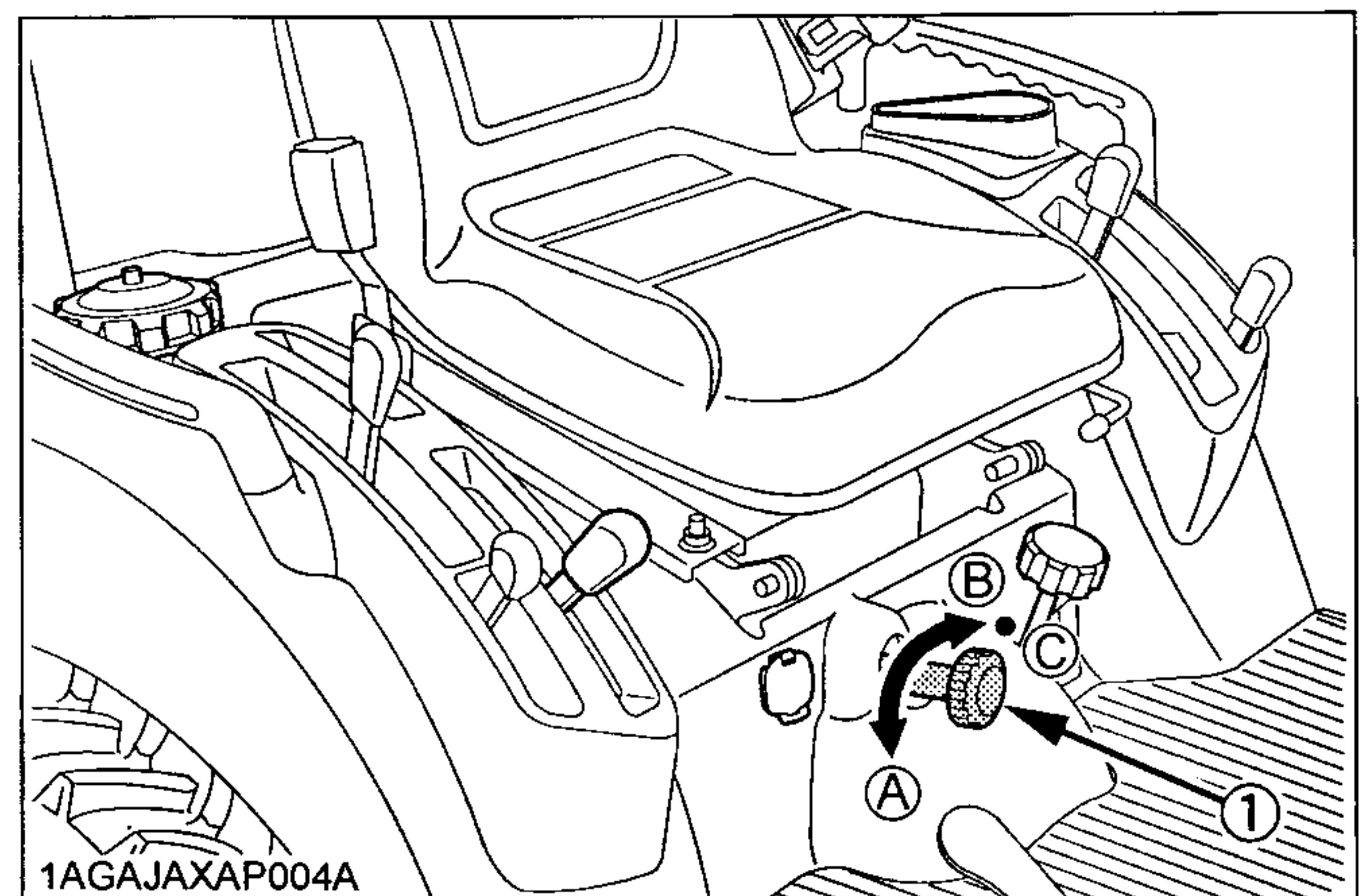

(1) 3-Point lowering speed knob (A) "FAST"
(B) "SLOW"
(C) "LOCK"

AUXILIARY HYDRAULICS

On the tractor hydraulic outlet is provided.

Hydraulic Outlet

Hydraulic outlet is useful when adding hydraulically operated equipment such as front end loader, front blade, etc.

When implement is attached

1. Remove the block cover.
2. Attach the block outlet cover. (option)
(The block outlet cover is standard part for KUBOTA Implements)
3. Route the implement inlet, outlet and return pipes as shown in the illustration.

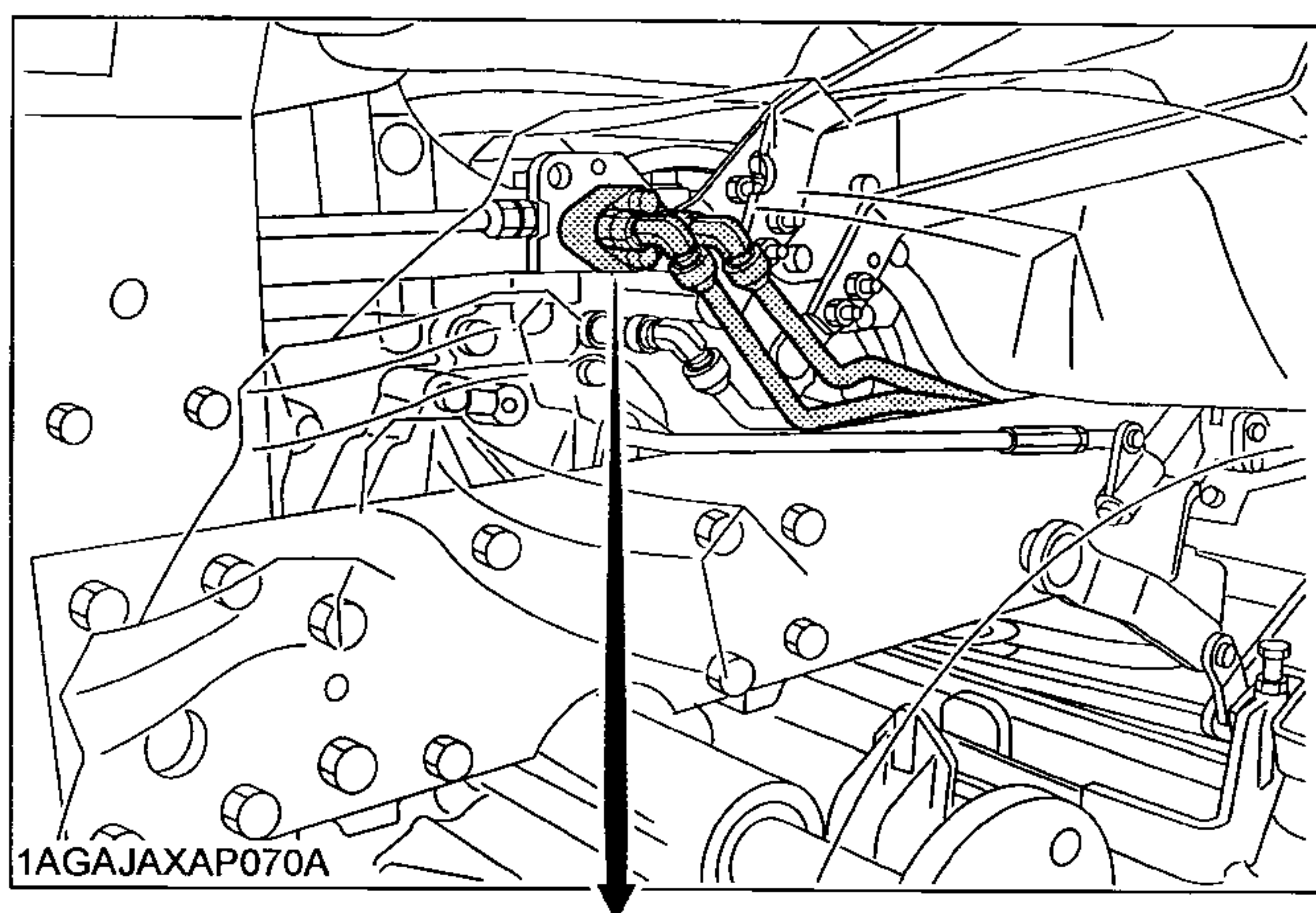

1AGA JAXAP070A

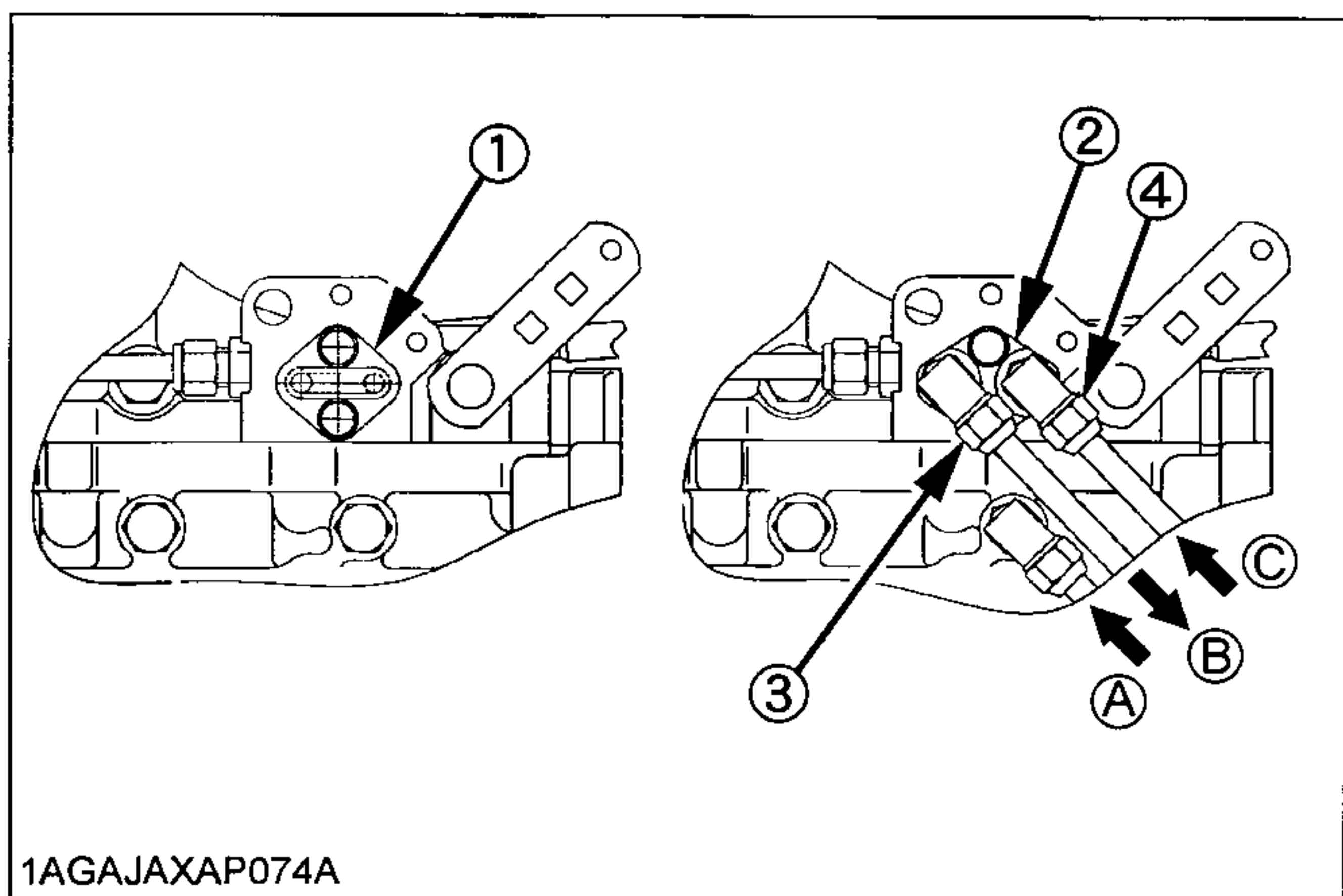

1AGA JAXAP074A

- | | |
|---------------------------------|----------------------------|
| (1) Block cover | (A) Return port |
| (2) Block outlet cover (option) | (B) To implement (outlet) |
| (3) Outlet | Max. flow |
| (4) Inlet | 14 L/min |
| | (3.7 U.S.gals./min) |
| | No relief valve in |
| | the hydraulic block. |
| | (C) From implement (inlet) |

IMPORTANT :

- For hydraulic outlet, be sure to use the control valve of the "Power beyond type" (with relief valve) and third line return to tank for the operation of hydraulic block.

MOWER LIFT LINKAGE SYSTEM

Cutting Height Control Dial

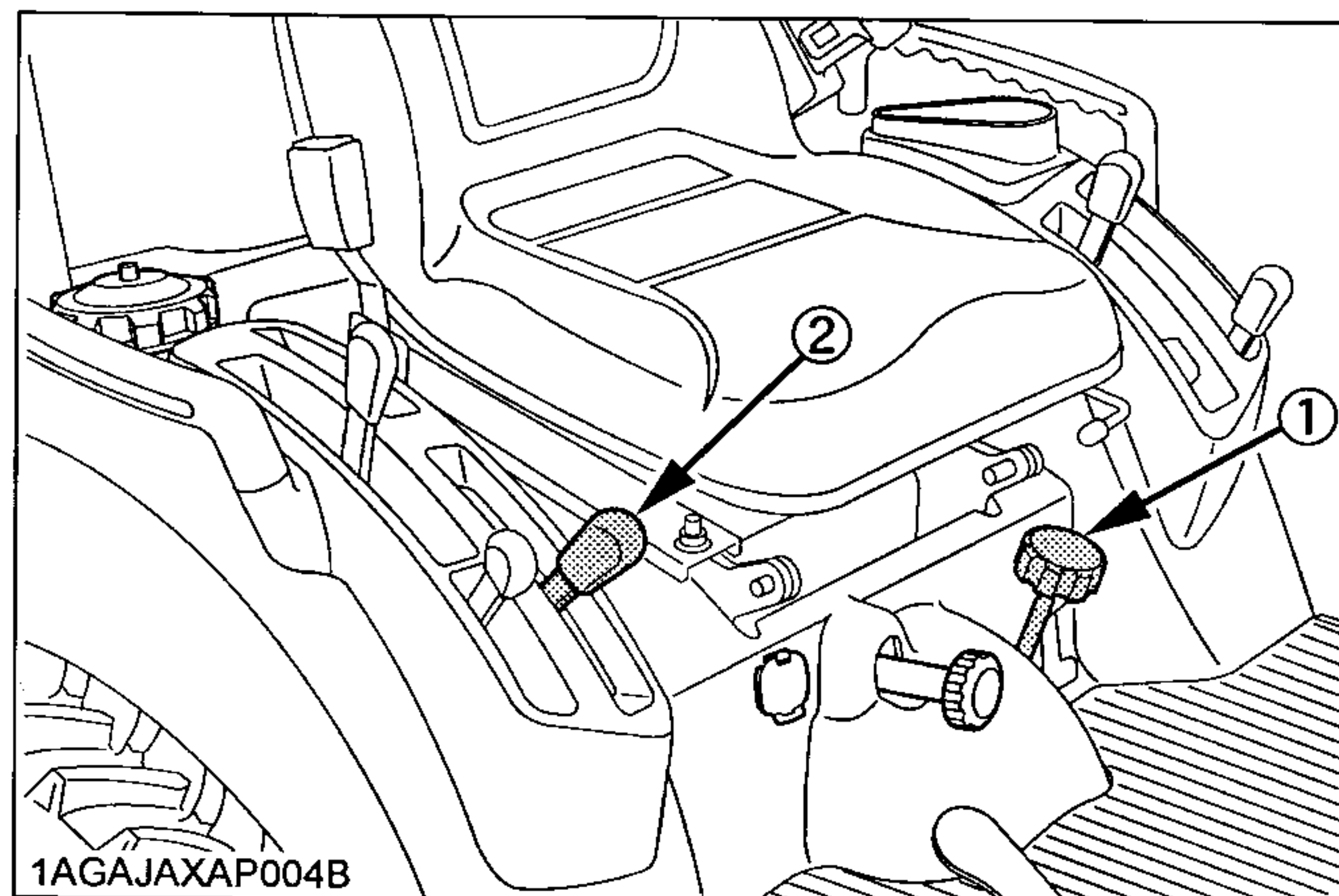

1AGA JAXAP004B

- (1) Cutting height control dial
- (2) Hydraulic control lever

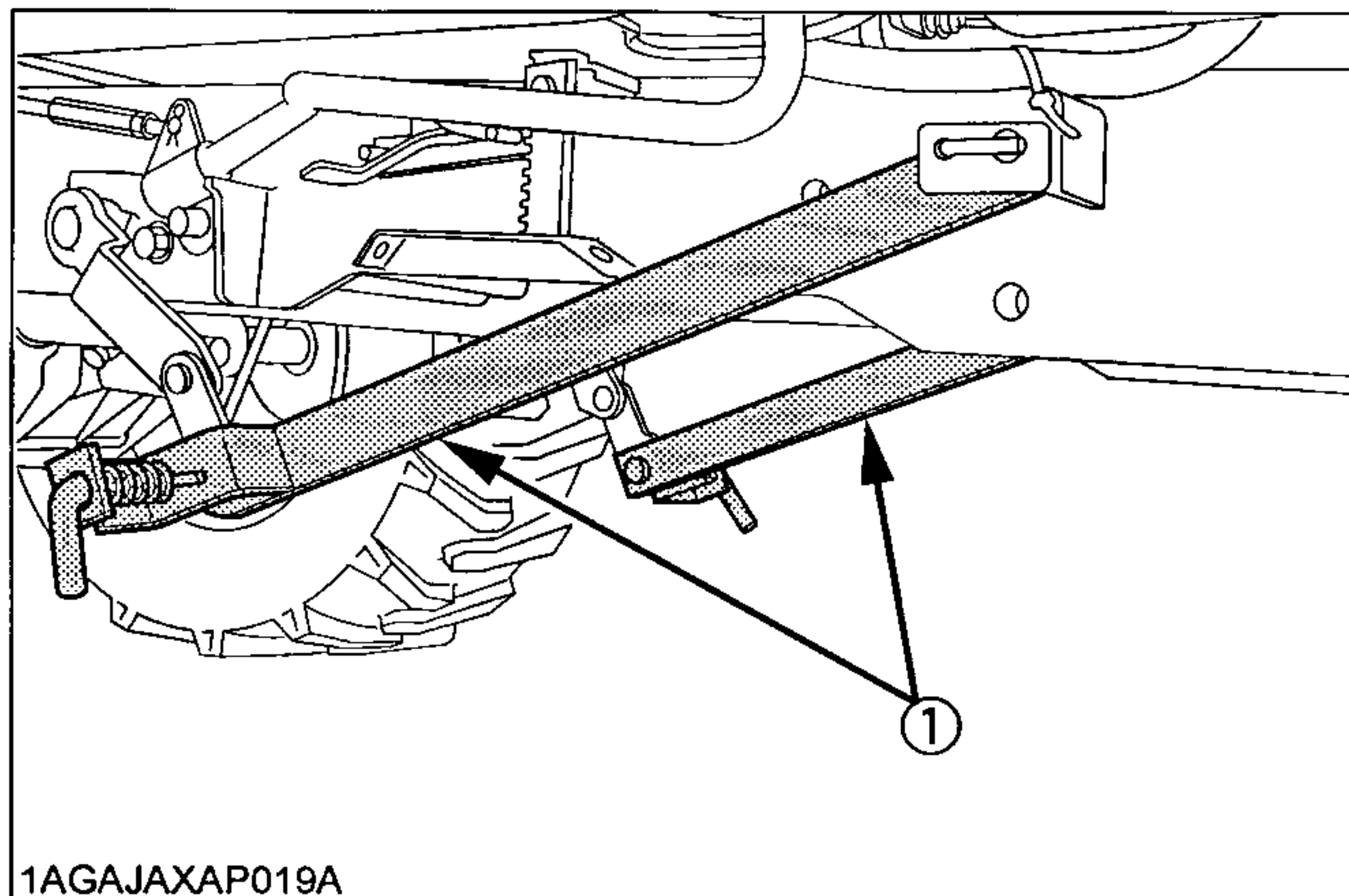

1AGA JAXAP019A

- (1) Mower rear link

When mounting the Mid-mount mower, turn the cutting height control dial to the desired height.

For further details, refer to the operator's manual of ROTARY MOWER RCK60B-23BX, RCK54P-23BX, RCK54-23BX, RCK48P-18BX, and RCK48-18BX.

IMPORTANT :

- When operating the tractor without Mid-mount mower:
1. Move the hydraulic lever rearward to raise the mower rear links to the highest position.
 2. Set the cutting height control dial to "TOP" position. Failure to do so could result in damage to the mower rear links.

If this is not done, damage of the mower rear link can result.

■Hydraulic Control Unit Use Reference Chart

In order to handle the hydraulics properly, the operator must be familiar with the following. Though this information may not be applicable to all types of implements and soil conditions, it is useful for general conditions.

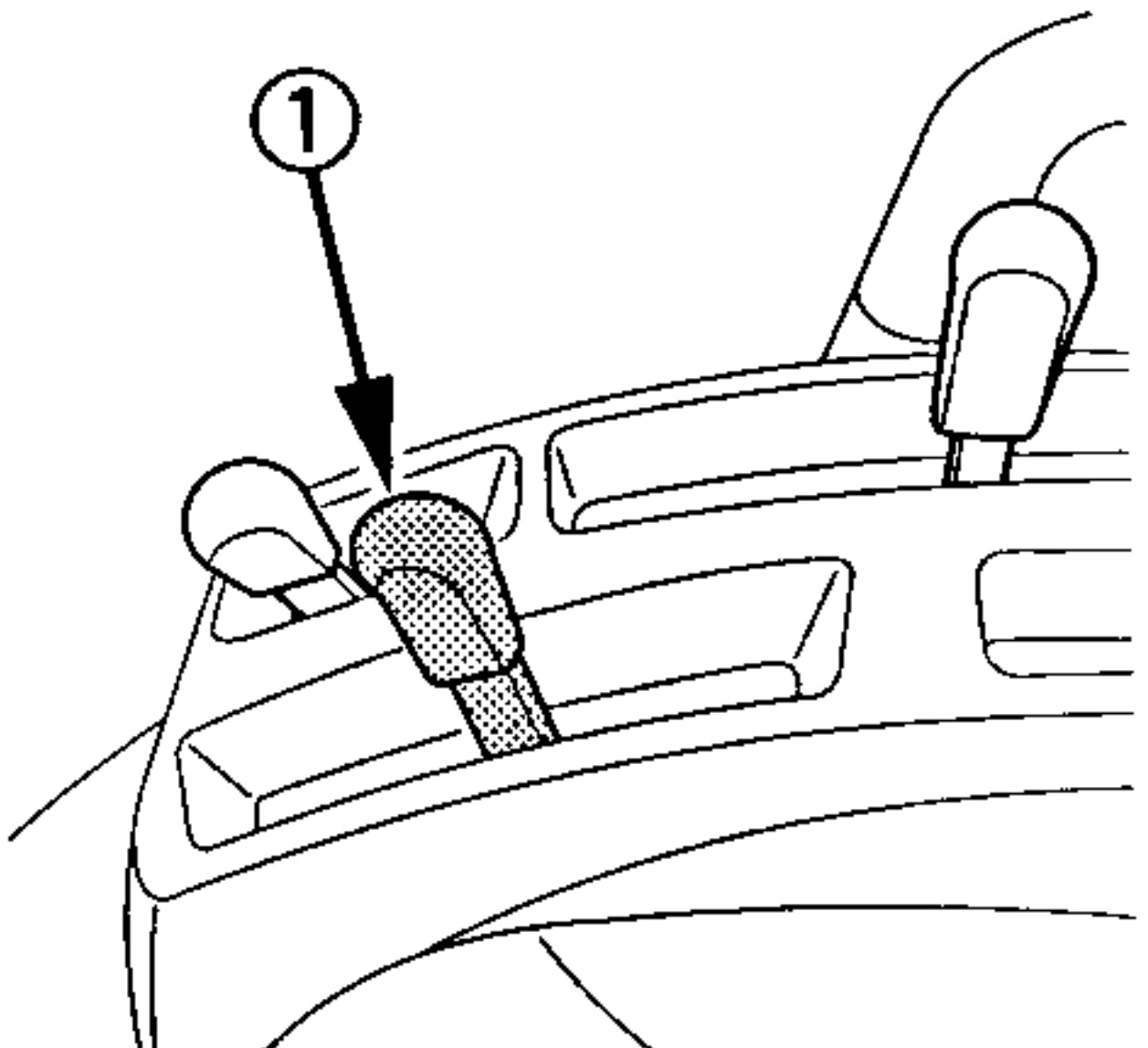
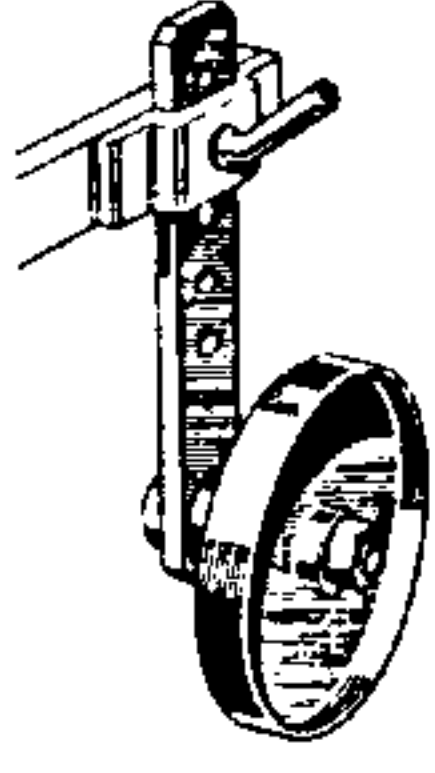
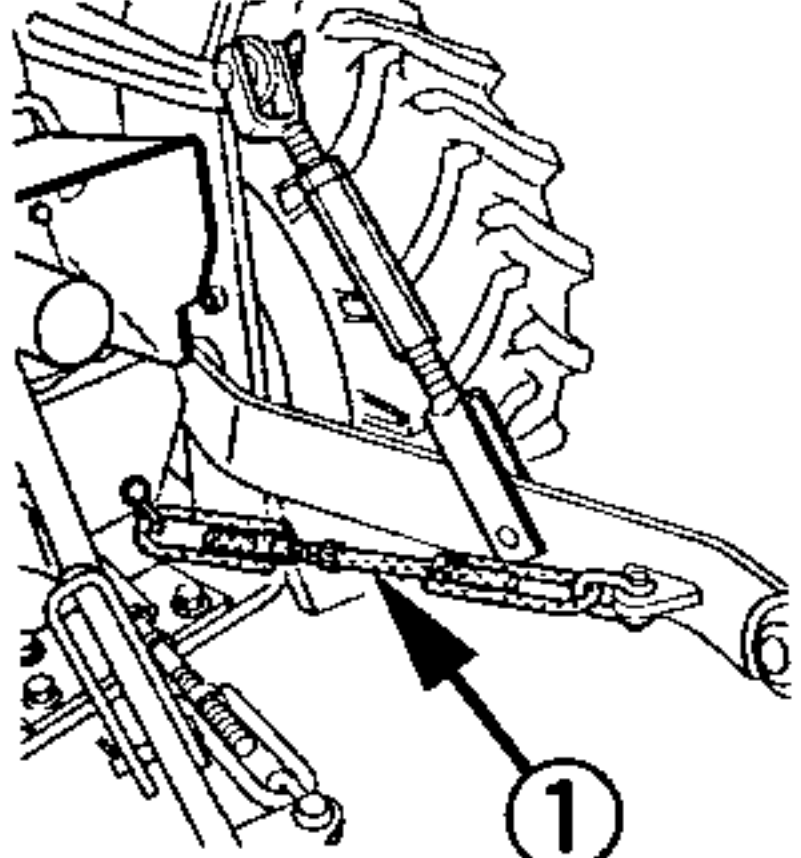
Implement	Soil condition	 1AGAJAXAP012F (1) Hydraulic control lever	 1AGAEBCAP0590 Gauge wheel	 1AGAJAXAP057C (1) Check chains	Remarks
Moldboard plow	Light soil Medium soil Heavy soil	Hydraulic control	YES/NO	Loose	Adjust the check chains so that the implement can move 5 to 6 cm (2.0 to 2.4 in.) laterally. Check chains should be tight enough to prevent excessive implement movement when implement is in raised position.
Disc plow	---				
Harrower (spike, springtooth, disc type)	---				
Sub-soiler.....	---		YES	Tighten	For implements with gauge wheels, lower the position control lever all way.
Weeder, ridger.....	---		YES/NO		
Earthmove, digger scraper, manure fork rear carrier....	---				
Mower (mid-and rear-mount type) Hayrake, tedder...	---				

AUXILIARY HYDRAULIC CONTROL VALVE (IF EQUIPPED)

CAUTION

To avoid serious personal injury:

- Escaping hydraulic fluid under pressure can have sufficient force to penetrate skin, causing serious personal injury.

Before disconnecting lines, be sure to relieve all pressure.

Before applying pressure to system, be sure all connections are tight and that lines, tubes and hoses are not damaged.

Fluid escaping from a very small hole can be almost invisible. Use a piece of cardboard or wood, rather than hands to search for suspected leaks.

If injured by escaping fluid, see a doctor at once. Serious infection or allergic reaction will develop if proper medical treatment is not administered immediately.

■ Valve Lock

CAUTION

To avoid injury from crushing:

- Do not utilize the valve lock for machine maintenance or repair.
- The valve lock is to prevent accidental actuation when implement is not in use or during transport.

The control valve is equipped with a valve lock feature. The control valve is locked in "NEUTRAL" position. The lock is not intended and will not prevent a leak down of the implement during the period of storage.

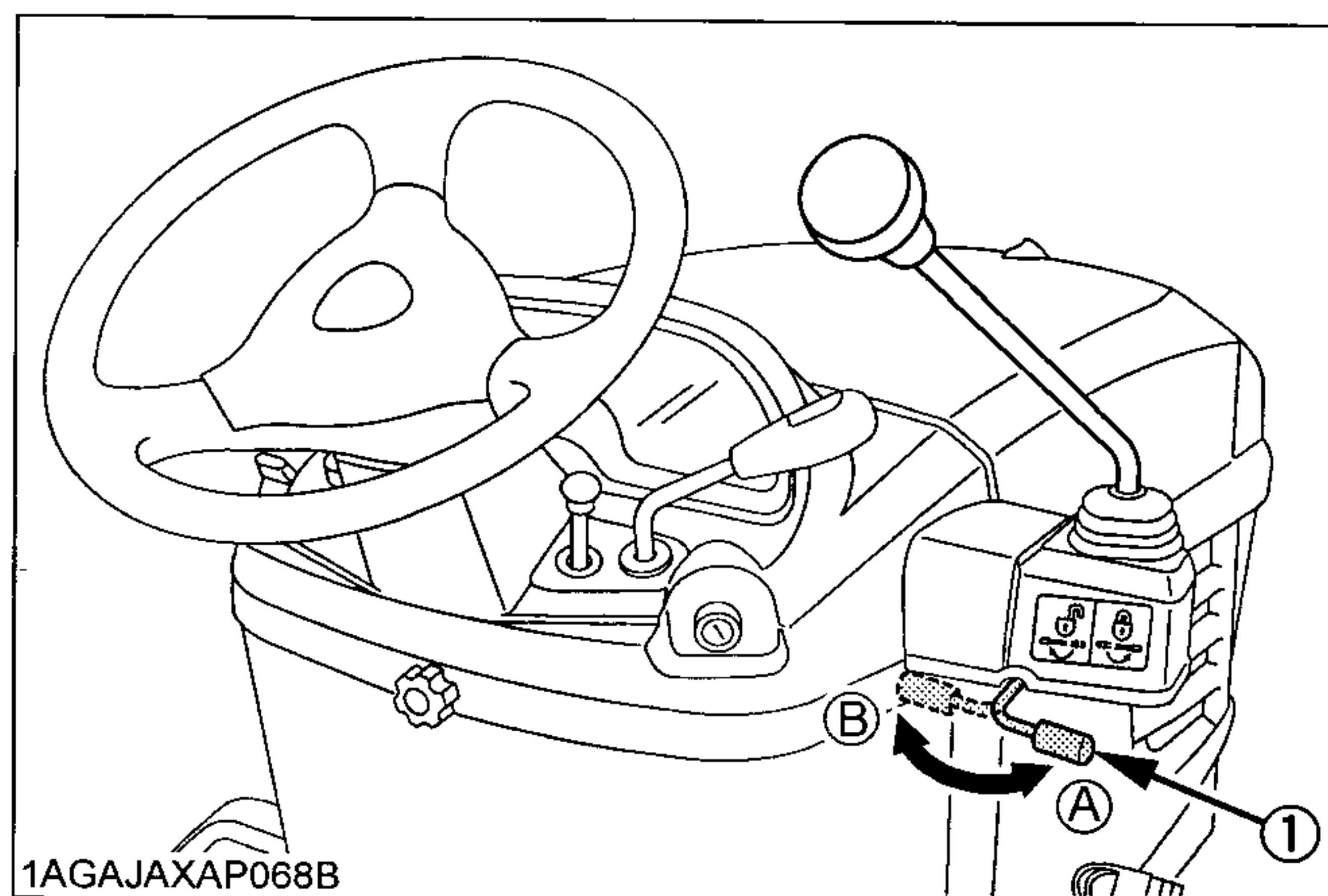

1AGAJAXAP068B

(1) Lock lever

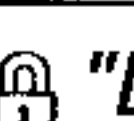
(A)  "LOCK"

(B)  "UNLOCK"

■ Auxiliary Hydraulic Ports

Auxiliary hydraulic ports are equipped with quick couplers. If you don't use the auxiliary hydraulic ports, place the protective plugs on the quick couplers ends.

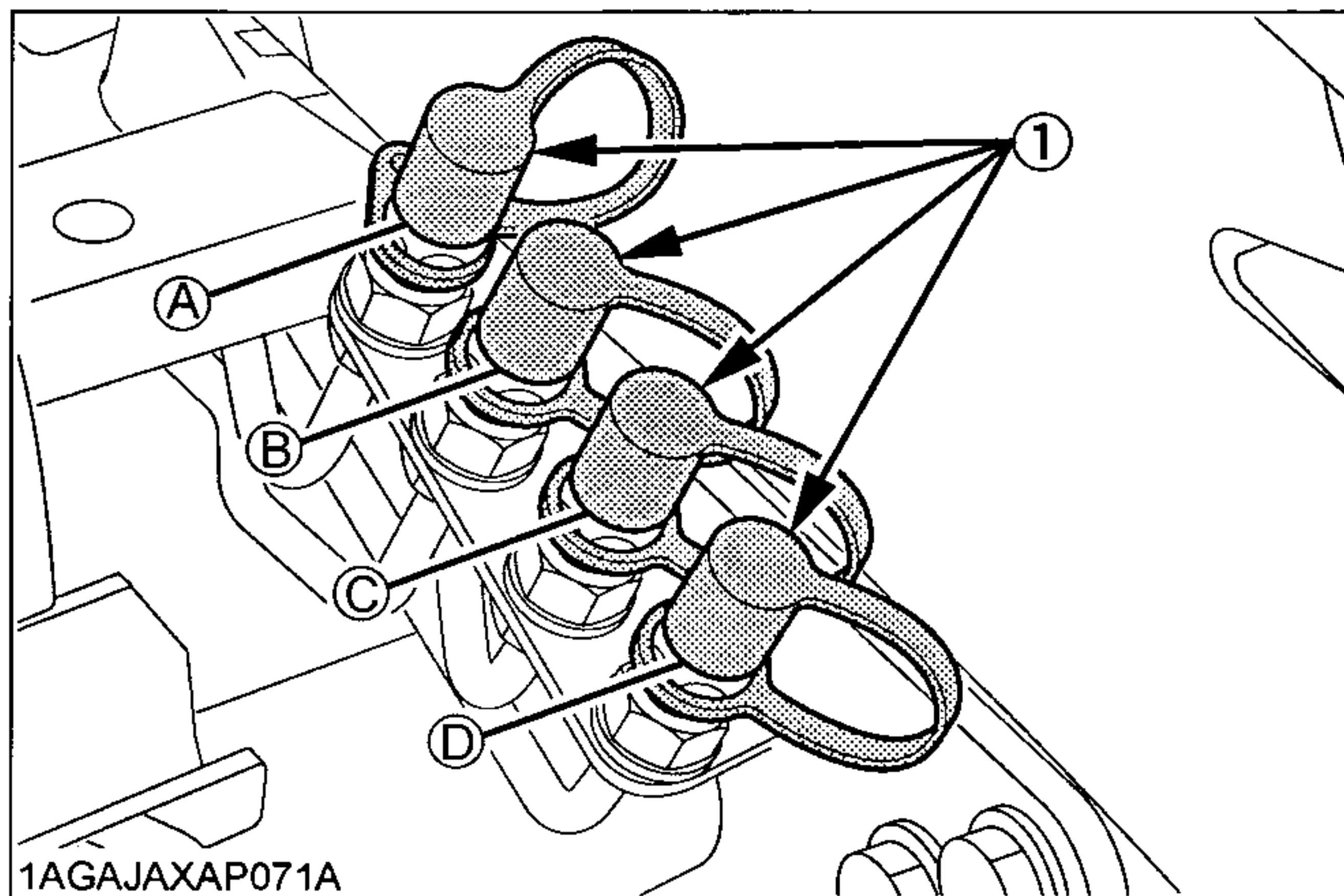

1AGAJAXAP071A

(1) Protective plugs

(A) "FORWARD" (WHITE)

(B) "RIGHT" (BLUE)

(C) "LEFT" (RED)

(D) "BACKWARD" (YELLOW)

■ Auxiliary Hydraulic Control Lever

	INLET	OUTLET
LEFT	BLUE	RED
RIGHT	RED	BLUE
FORWARD	YELLOW	WHITE
BACKWARD	WHITE	YELLOW

When the implement hydraulic couplers are connected WHITE (A) and YELLOW (D), move the auxiliary hydraulic control lever forward to divert fluid to the white line and return to the yellow line.

Move the lever backward to divert fluid to the yellow line and return to the white line.

Move the lever to the full forward, to remove pressure in the connector lines.

When the implement hydraulic couplers are connected BLUE (B) and RED (D), move the auxiliary hydraulic control lever left to divert fluid to the red line and return to the blue line.

[With the loader in place]

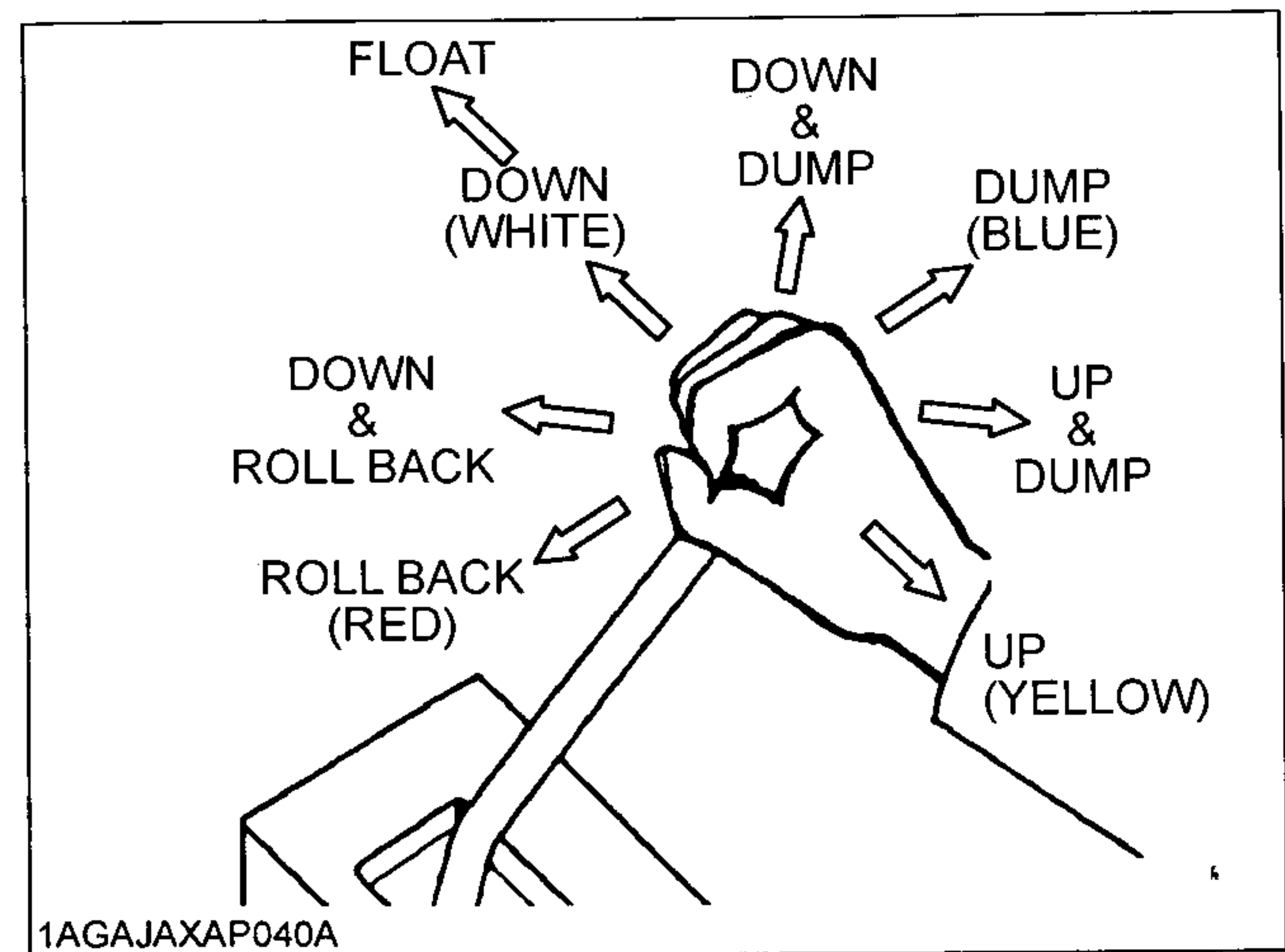

This control valve has two stage dump positions. The first "Regenerative" dump position activated by moving the lever to the right features high speed for efficient normal loader operations.

The second "Regular" dump position activated by moving the lever further to the right features increased power. This second position should be used when operating implements other than the loader with this control valve. These two positions are separated by a "Feel" position for your convenience.

TIRES, WHEELS AND BALLAST

TIRES



WARNING

To avoid personal injury:

- Do not attempt to mount a tire on a rim. This should be done by a qualified person with the proper equipment.
- Always maintain the correct tire pressure. Do not inflate tires above the recommended pressure shown in the operator's manual.

IMPORTANT :

- Do not use tires other than those approved by KUBOTA.
- When you intend to mount different size of tires from equipped ones, consult your dealer about front drive gear ratio for details.
Excessive wear of tires may occur due to improper gear ratio.

■ Inflation Pressure

Though the tire pressure is factory-set to the prescribed level, it naturally drops slowly in the course of time. Thus, check it everyday and inflate as necessary.

[BX1850]

	Tire sizes	Inflation Pressure
Rear	24x12.00-12 Turf 24x12.00-12 Bar	100kPa(1.0kgf/cm ² , 14psi) 120kPa(1.2kgf/cm ² , 17psi)
Front	16x7.50-8 Turf 16x7.50-8 Bar	120kPa(1.2kgf/cm ² , 17psi) 150kPa(1.5kgf/cm ² , 22psi)

[BX2350]

	Tire sizes	Inflation Pressure
Rear	26x12.00-12 Turf 26x12.00-12 Bar 26x12.00-12 Ind.	100kPa(1.0kgf/cm ² , 14psi) 120kPa(1.2kgf/cm ² , 17psi) 120kPa(1.2kgf/cm ² , 17psi)
Front	18x8.50-10 Turf 18x8.50-10 Bar 18x8.50-10 Ind.	120kPa(1.2kgf/cm ² , 17psi) 150kPa(1.5kgf/cm ² , 22psi) 150kPa(1.5kgf/cm ² , 22psi)

NOTE :

- Maintain the maximum pressure in front tires, if using a front loader or when equipped with a full load of front weight.

WHEEL TREAD



CAUTION

To avoid personal injury:

- Support tractor securely on stands before removing a wheel.
- Never operate tractor with a loose rim, wheel, or axle.

■ Front Wheels

Front tread can not be adjusted.

IMPORTANT :

- Do not turn front discs to obtain wider tread.

Models	BX1850	BX2350
Tire	16x7.50-8 Turf, 16x7.50-8 Bar	18x8.50-10 Turf, 18x8.50-10 Bar, 18x8.50-10 Ind.
Tread	<p style="text-align: center;">880 mm 34.6 in. 1AGA JADAP130B</p>	<p style="text-align: center;">910 mm 35.8 in. 1AGA JAXAP075A</p>

■ Rear Wheels

Rear tread width can not be adjusted.

IMPORTANT :

- Do not turn rear discs to obtain wider tread.

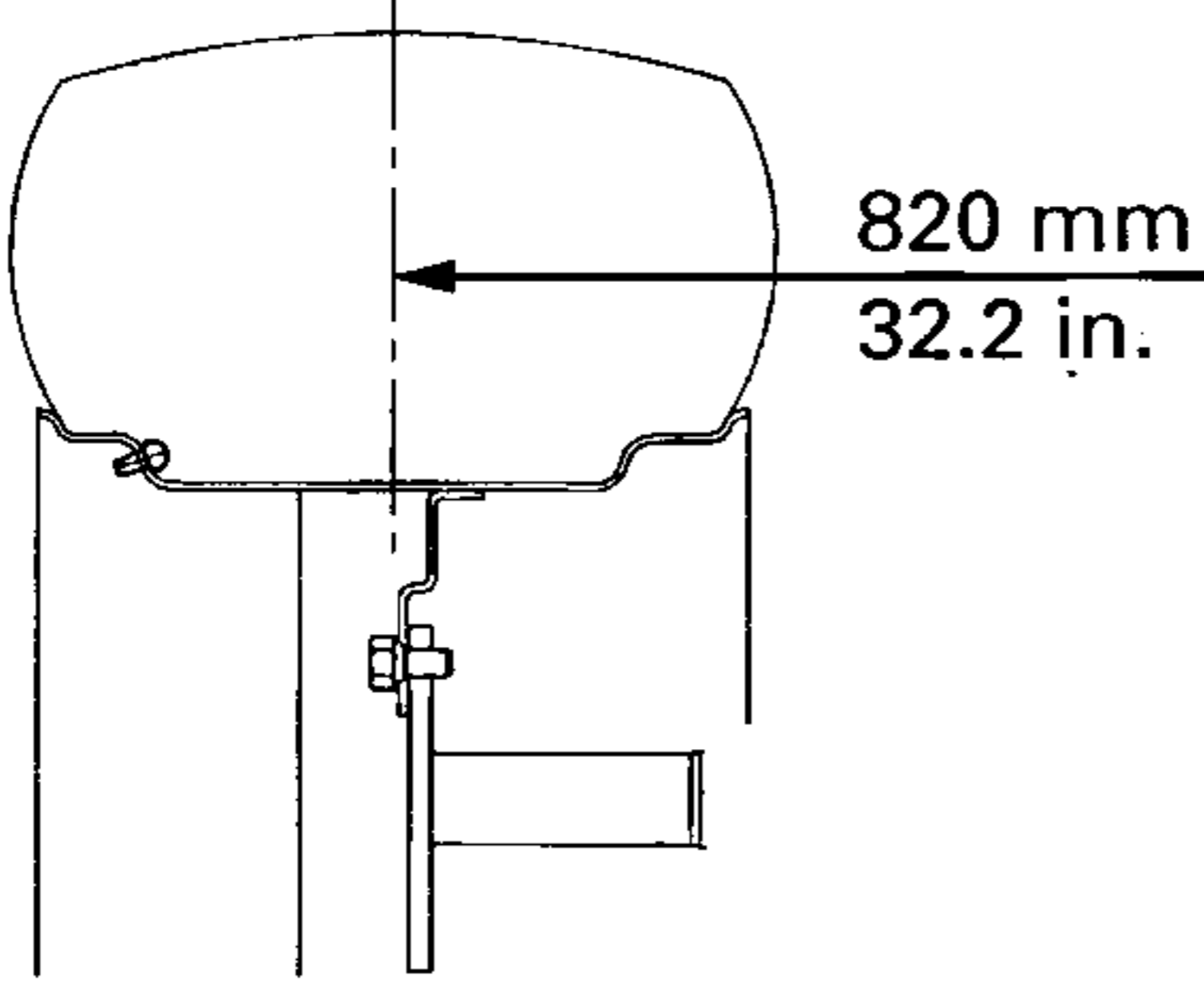
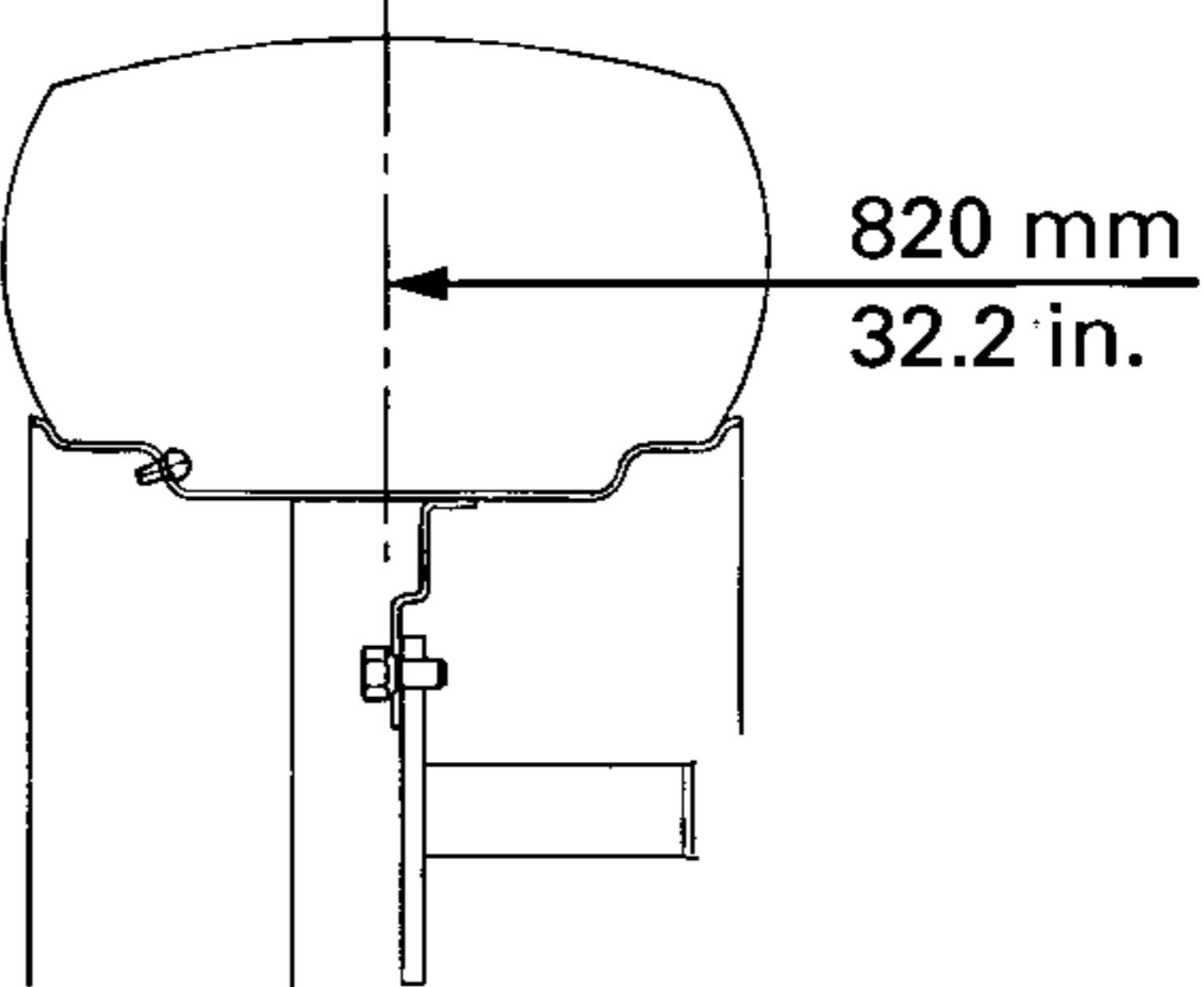
Models	BX1850	BX2350
Tire	24x12.00-12 Turf, 24x12.00-12 Bar	26x12.00-12 Turf, 26x12.00-12 Bar, 26x12.00-12 Ind.
Tread	 <p>820 mm 32.2 in.</p> <p>1HNAAAAAP064A</p>	 <p>820 mm 32.2 in.</p> <p>1HNAAAAAP065A</p>

IMPORTANT :

- Always attach tires as shown in the drawings.
- If not attached as illustrated, transmission parts may be damaged. When re-fitting or adjusting a wheel, tighten the bolts to the following torques then recheck after driving the tractor 200m (200yards), after one day (8hours) and thereafter every 50 hours (as per maintenance chart).

NOTE :

- Use the tapered bolts for wheels with beveled or tapered holes.

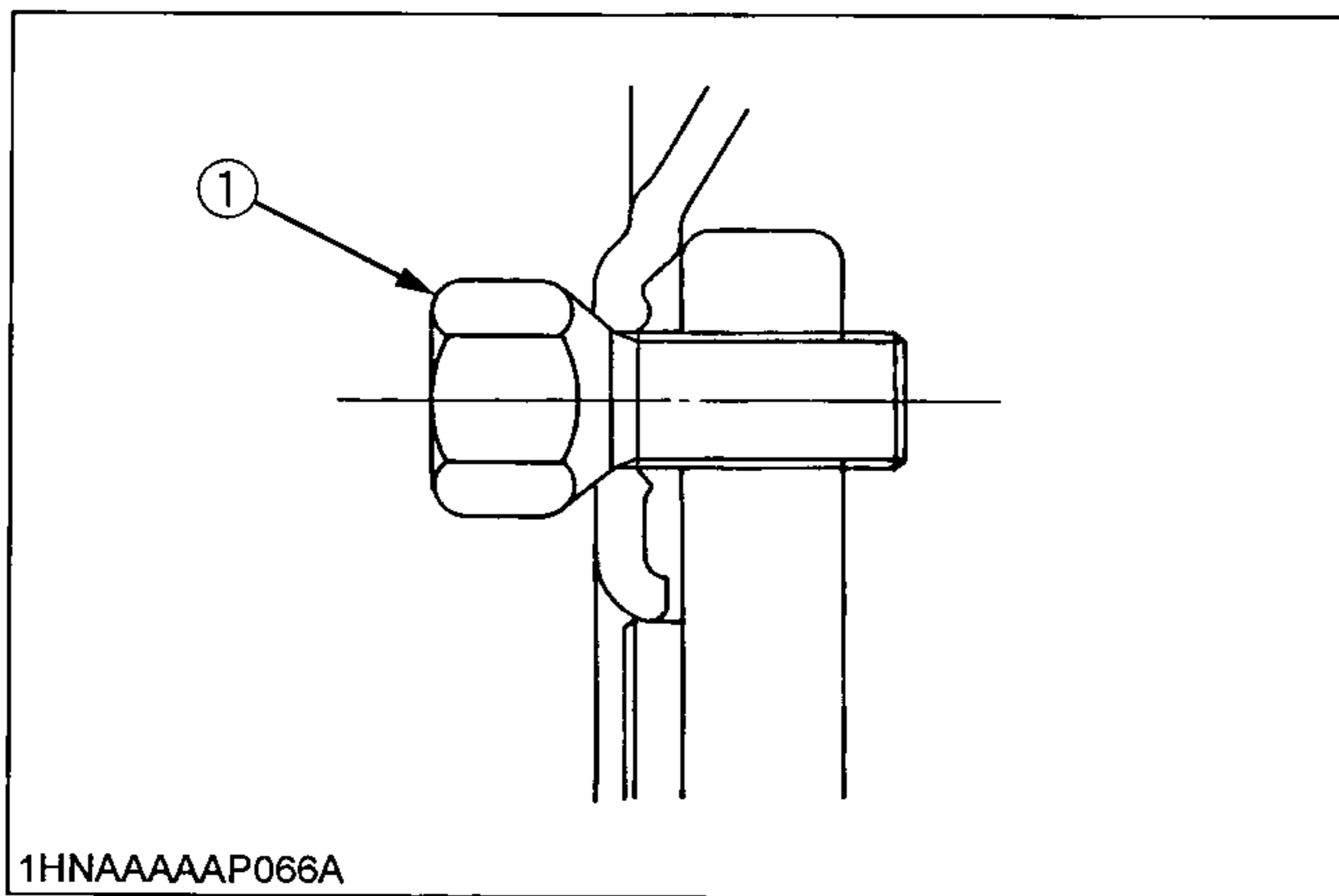

(1) Bolt

Front 149.2 to 179.0 N-m
(15.2 to 18.3 kgf-m)
(110 to 132 ft-lbs.)
Rear 108.5 to 130.2 N-m
(11.1 to 13.3 kgf-m)
(80 to 96 ft-lbs.)

BALLAST

CAUTION

To avoid personal injury:

- Additional ballast will be needed for transporting heavy implements. When the implement is raised, drive slowly over rough ground, regardless of how much ballast is used.
- Do not fill the front wheels with liquid to maintain steering control.

■ Front Ballast

Add weights if needed for stability and improve traction. Heavy pulling and heavy rear mounted implements tend to lift front wheels. Add enough ballast to maintain steering control and prevent tip over. Remove weight when no longer needed.

◆ Front End Weights (option)

The front end weights can be attached to the bumper. See your implement operator's manual for required number of weights or consult your local KUBOTA Dealer to use.

NOTE :

- Besides the weight, a front weight bracket and mounting bolt kit(s) are required for mounting the weight.

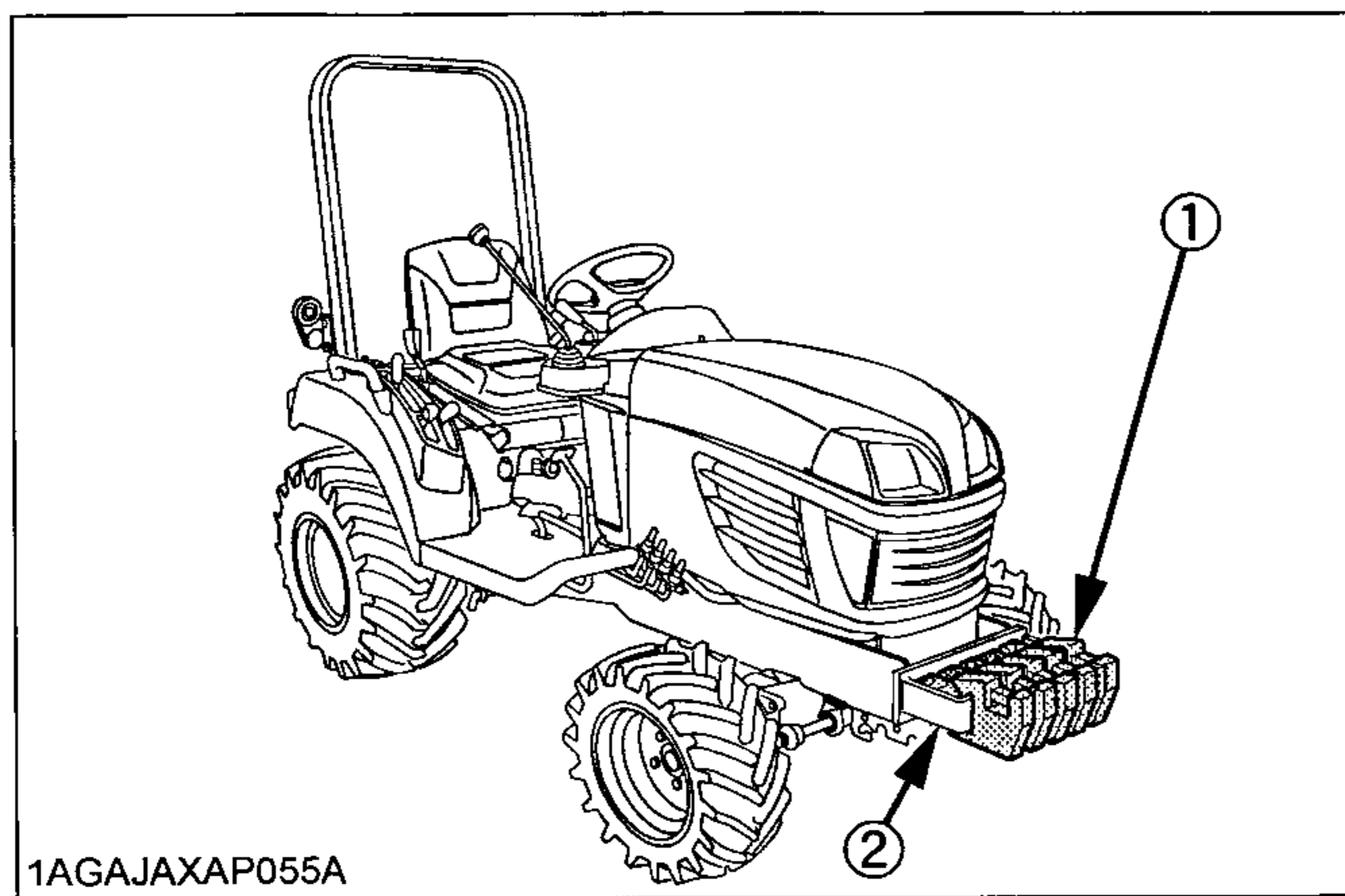

(1) Front end weights
(2) Front weight bracket (option)

IMPORTANT :

- Do not overload tires.
- Add no more weight than indicated in chart.

Maximum weight	125 kg (275 lbs.)
----------------	-------------------

■ Rear Ballast

Add weight to rear wheels if needed to improve traction or for stability. The amount of rear ballast should be matched to job and the ballast should be removed when it is not needed.

The weight should be added to the tractor in the form of liquid ballast.

◆ Liquid Ballast in Rear Tires

Water and calcium chloride solution provides safe economical ballast. Used properly, it will not damage tires, tubes or rims. The addition of calcium chloride is recommended to prevent the water from freezing. Use of this method of weighting the wheels has the full approval of the tire companies. See your tire dealer for this service. Liquid weight per tire (75 percent filled)

Tire sizes	24x12.00-12 (BX1850)	26x12.00-12 (BX2350)
Slush free at -10°C (14°F) Solid at -30°C (-22°F) [Approx. 1 kg (2 lbs.) CaCl ₂ per 4 L (1 gal) of water]	35 kg (77 lbs.)	45 kg (99 lbs.)
Slush free at -24°C (-11°F) Solid at -47°C (-52°F) [Approx. 1.5 kg (3.5 lbs.) CaCl ₂ per 4 L (1 gal) of water]	38 kg (84 lbs.)	50 kg (110 lbs.)
Slush free at -47°C (-52°F) Solid at -52°C (-62°F) [Approx. 2.25 kg (5 lbs.) CaCl ₂ per 4 L (1 gal) of water]	44 kg (97 lbs.)	56 kg (123 lbs.)

IMPORTANT :

- Do not fill tires with water or solution more than 75% of full capacity (to the level of valve stem at 12 o'clock position).

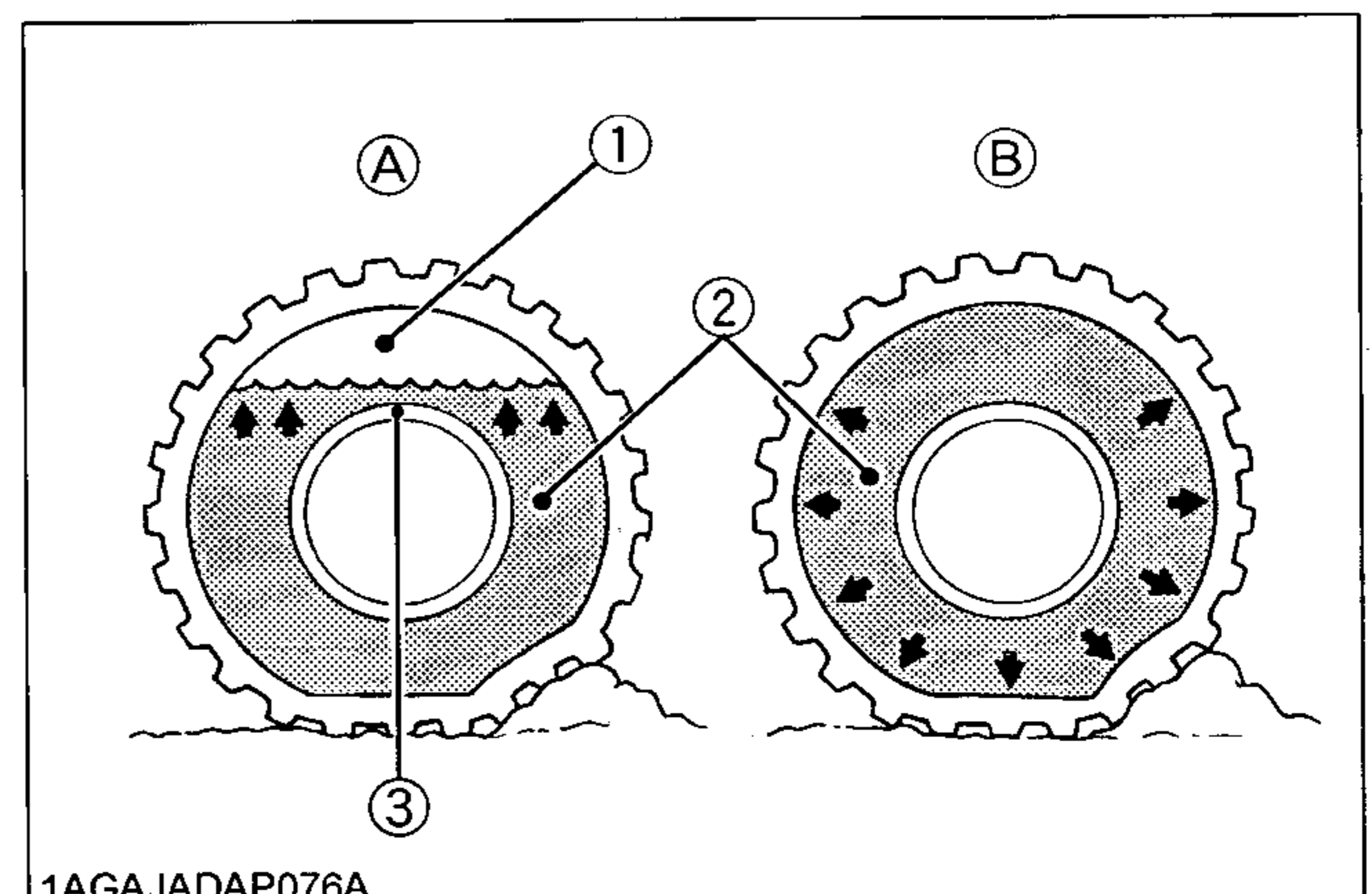

(1) Air
(2) Water
(3) Valve stem
(A) Correct : 75% Full
Air compresses like a cushion
(B) Incorrect : 100% Full
Water can not be compressed

- To avoid damage of transmission, do not use rear wheel weights and liquid ballast at the same time.

MAINTENANCE

SERVICE INTERVALS

No.	Items		Indication on hour meter									Since then	Ref. page				
			50	100	150	200	250	300	350	400	450						
1	Engine oil	Change	☉	○		○		○		○		○		every 100 Hr	47		
2	Engine oil filter	Replace	☉			○						○		every 200 Hr	50		
3	Transmission oil filter	Replace	☉							○				every 300 Hr	54		
4	Transmission fluid	Change	☉							○				every 300 Hr	53		
5	Transmission strainer	Clean								○				every 300 Hr	53		
6	Front axle case oil	Change								○				every 300 Hr	54		
7	Front axle pivot	Adjust										○		every 400 Hr	55		
8	Engine start system	Check	○	○	○	○	○	○	○	○	○	○	○	every 50 Hr	44		
9	Greasing	--	○	○	○	○	○	○	○	○	○	○	○	every 50 Hr	43		
10	Wheel bolt torque	Check	○	○	○	○	○	○	○	○	○	○	○	every 50 Hr	45		
11	Battery condition	Check		○		○		○		○		○		every 100 Hr	45	*5	
12	Air cleaner element	Clean		○		○		○		○		○		every 100 Hr	48	*1	@
		Replace												every 1 year	55	*2	
13	Fuel filter element	Check		○		○		○		○		○		every 100 Hr	48		@
		Replace												every 500 Hr	55		
14	Fan belt	Adjust		○		○		○		○		○		every 100 Hr	49		
15	HST neutral spring	Adjust		○		○		○		○		○		every 100 Hr	49		
16	Brake	Adjust		○		○		○		○		○		every 100 Hr	50		
17	Radiator hose and clamp	Check				○						○		every 200 Hr	51		
		Replace												every 2 years	57		
18	Power steering oil line	Check				○						○		every 200 Hr	52		
		Replace												every 2 years	57		
19	Fuel line	Check		○		○		○		○		○		every 100 Hr	48		@
		Replace												every 2 years	57		
20	Intake air line	Check				○						○		every 200 Hr	51		@
		Replace												every 2 years	57	*4	
21	Toe-in	Adjust				○						○		every 200 Hr	52		
22	Engine valve clearance	Adjust												every 800 Hr	55	*4	
23	Fuel injection nozzle Injection pressure	Check												every 1500 Hr	55	*4	@
24	Injection pump	Check												every 3000 Hr	55	*4	@
25	Cooling system	Flush												every 2 years	55		
26	Coolant	Change												every 2 years	55		
27	Fuel system	Bleed												Service as required	57		
28	Fuse	Replace													58		
29	Light bulb	Replace													58		

No.	Items		Indication on hour meter					Since then	Ref. page		
			500	550	600	650	700				
1	Engine oil	Change	○		○		○	every 100 Hr	47		
2	Engine oil filter	Replace			○			every 200 Hr	50		
3	Transmission oil filter	Replace			○			every 300 Hr	54		
4	Transmission fluid	Change			○			every 300 Hr	53		
5	Transmission strainer	Clean			○			every 300 Hr	53		
6	Front axle case oil	Change			○			every 300 Hr	54		
7	Front axle pivot	Adjust						every 400 Hr	55		
8	Engine start system	Check	○	○	○	○	○	every 50 Hr	44		
9	Greasing	--	○	○	○	○	○	every 50 Hr	43		
10	Wheel bolt torque	Check	○	○	○	○	○	every 50 Hr	45		
11	Battery condition	Check	○		○		○	every 100 Hr	45	*5	
12	Air cleaner element	Clean	○		○		○	every 100 Hr	48	*1	@
		Replace						every 1 year	55	*2	
13	Fuel filter element	Check	○		○		○	every 100 Hr	48		@
		Replace	○					every 500 Hr	55		
14	Fan belt	Adjust	○		○		○	every 100 Hr	49		
15	HST neutral spring	Adjust	○		○		○	every 100 Hr	49		
16	Brake	Adjust	○		○		○	every 100 Hr	50		
17	Radiator hose and clamp	Check			○			every 200 Hr	51		
		Replace						every 2 years	57		
18	Power steering oil line	Check			○			every 200 Hr	52		
		Replace						every 2 years	57		
19	Fuel line	Check	○		○		○	every 100 Hr	48		@
		Replace						every 2 years	57		
20	Intake air line	Check			○			every 200 Hr	51		@
		Replace						every 2 years	57	*4	
21	Toe-in	Adjust			○			every 200 Hr	52		
22	Engine valve clearance	Adjust						every 800 Hr	55	*4	
23	Fuel injection nozzle Injection pressure	Check						every 1500 Hr	55	*4	@
24	Injection pump	Check						every 3000 Hr	55	*4	@
25	Cooling system	Flush						every 2 years	55		
26	Coolant	Change						every 2 years	55		
27	Fuel system	Bleed						Service as required	57		
28	Fuse	Replace							58		
29	Light bulb	Replace							58		

IMPORTANT :

● The jobs indicated by ⊙ must be done after the first 50 hours of operation.

*1 Air cleaner should be cleaned more often in dusty conditions than in normal conditions.

*2 Every year or every 6 times of cleaning.

*3 Replace only if necessary.

*4 Consult your local KUBOTA Dealer for this service.

*5 When the battery is used for less than 100 hours per year, check the battery condition by reading the indicator annually.

● The items listed above (@ marked) are registered as emission related critical parts by KUBOTA in the U.S.EPA nonroad emission regulation. As the engine owner, you are responsible for the performance of the required maintenance on the engine according to the above instruction.

Please see Warranty Statement in detail.

LUBRICANTS

No.	Locations	Capacities		Lubricants	
		BX1850	BX2350		
1	Fuel	25 L (6.6 U.S.gals.)		No. 2-D diesel fuel No. 1-D diesel fuel if temperature is below -10 °C (14 °F)	
2	Coolant (with recovery tank)	2.9 L (3.06 U.S.qts.)	3.1 L (3.3 U.S.qts.)	Fresh clean water with anti-freeze	
3	Engine crankcase	2.9 L (3.06 U.S.qts.)	3.1 L (3.3 U.S.qts.)	• Engine oil : API Service Classification CD, CE or CF	
				Above 25 °C (77 °F)	SAE30, SAE10W-30 or 10W-40
				0 to 25 °C (32 to 77 °F)	SAE20, SAE10W-30 or 10W-40
				Below 0 °C (32 °F)	SAE10W, SAE10W-30 or 10W-40
4	Transmission case	11.6 L (3.1 U.S.gals.)		• KUBOTA SUPER UDT fluid*	
5	Front axle case	2.3 L (2.4 U.S.qts.)	4.7 L (5.0 U.S.qts.)	• KUBOTA SUPER UDT fluid* or SAE 80 - SAE90 gear oil	
6	Greasing	No. of greasing points		Capacity	Type of grease
	Battery terminal	2		moderate amount	Multipurpose Grease NLGI-2 OR NLGI-1 (GC-LB)
	Speed control pedal	1		until grease overflow	

NOTE: *KUBOTA SUPER UDT --- KUBOTA original transmission hydraulic fluid

NOTE :

- Engine oil:
Oil used in the engine should have an American Petroleum Institute (API) service classification and Proper SAE Engine Oil according to the ambient temperatures as shown above.
- With the emission control now in effect, the CF-4 and CG-4 lubricating oils have been developed for use of a low-sulfur fuel on on-road vehicle engines. When an off-road vehicle engine runs on a high-sulfur fuel, it is advisable to employ the CF, CD or CE lubricating oil with a high total base number. **If the CF-4 or CG-4 lubricating oil is used with a high-sulfur fuel, change the lubricating oil at shorter intervals.**
- Lubricating oil recommended when a low-sulfur fuel is employed.

○: Recommendable X: Not Recommendable

Lubricating oil class	Fuel		Remark
	Low-sulfur	High-sulfur	
CF	○	○	TBN ≥ 10
CF-4	○	X	
CG-4	○	X	

- Transmission oil:
The oil used to lubricate the transmission is also used as hydraulic fluid. To insure proper operation of the hydraulic system and complete lubrication of the transmission, it is important that a multi-grade transmission fluid be used in this system. We recommend the use of **KUBOTA SUPER UDT fluid** for optimum protection and performance. (Consult your local KUBOTA Dealer for further detail.)
Do not mix different brands together.
- Indicated capacity of water and oil are manufacturer's estimate.

PERIODIC SERVICE



CAUTION

To avoid personal injury:

- Do not work under any hydraulically supported devices. They can settle, suddenly leak down, or be accidentally lowered. If necessary to work under tractor or any machine elements for servicing or adjustment, securely support them with stands or suitable blocking beforehand.

HOW TO OPEN THE HOOD



CAUTION

To avoid personal injury from contact with moving parts;

- Never open the hood or engine side cover while the engine is running.
- Do not touch muffler or exhaust pipes while they are hot;
Severe burns could result.

■ Hood

To open the hood, rotate the knob to release the latch and open the hood.

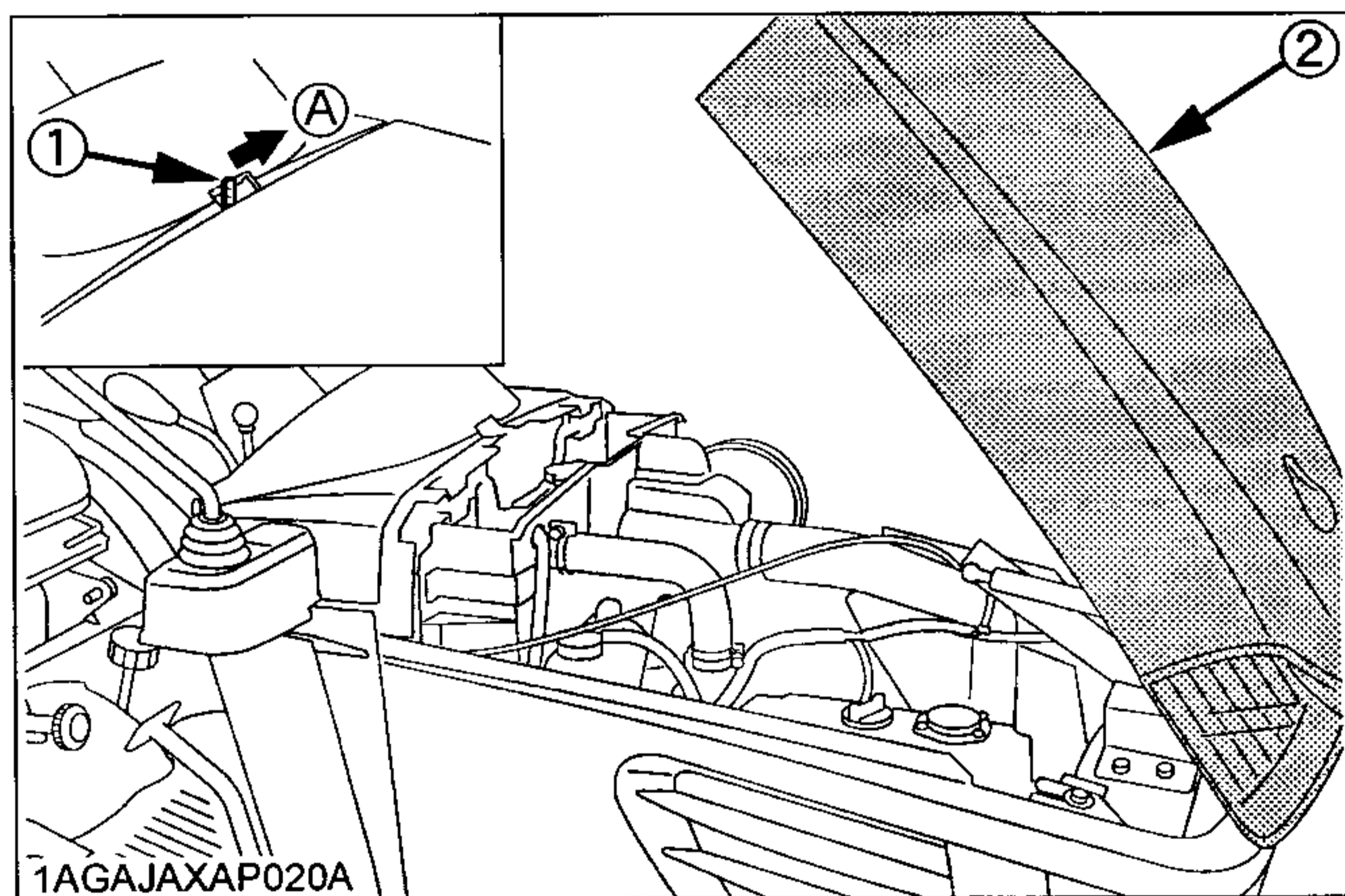

(1) Knob
(2) Hood

(A) "ROTATE"

■ Engine Cover

To remove the engine cover, loosen the knob bolts. Close the hood half way and fix the band to the hood. Then, hold the hood with the band, and pull forward as shown in following figure.

In the above procedure, be careful not to hit the engine cover against the head lights.

It is not necessary to detach the engine cover for daily check.

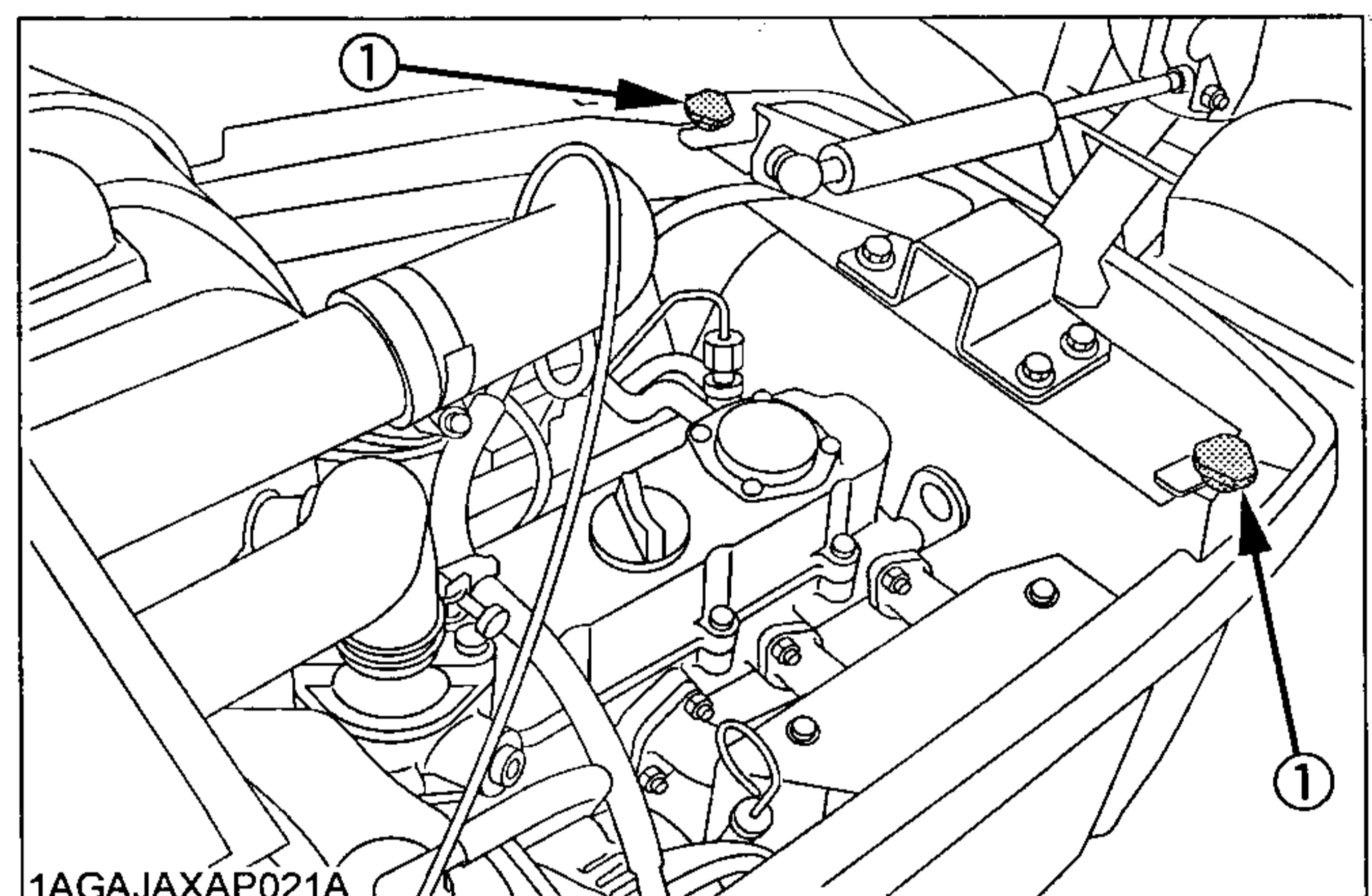

(1) Knob bolts

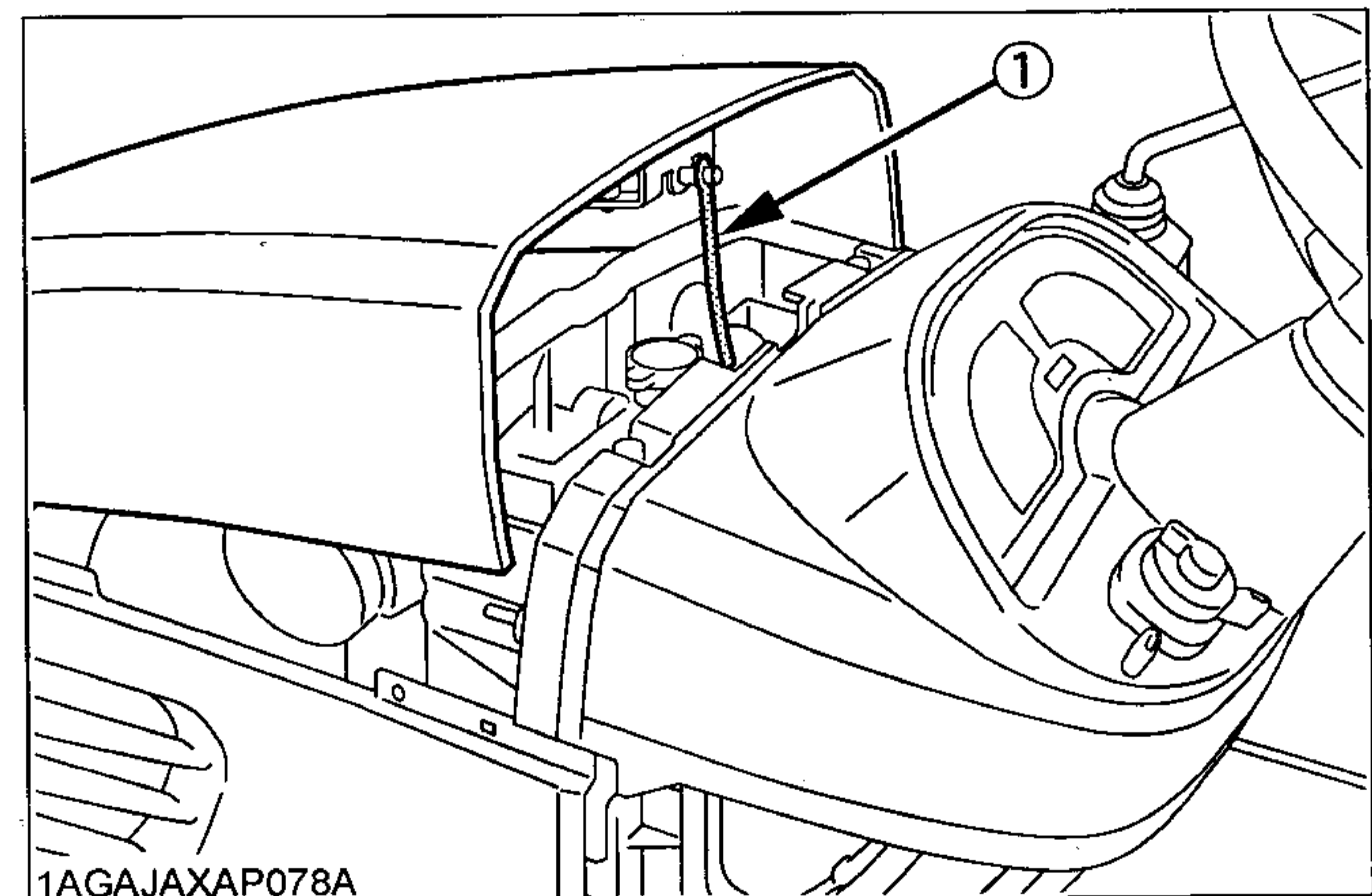

(1) Band

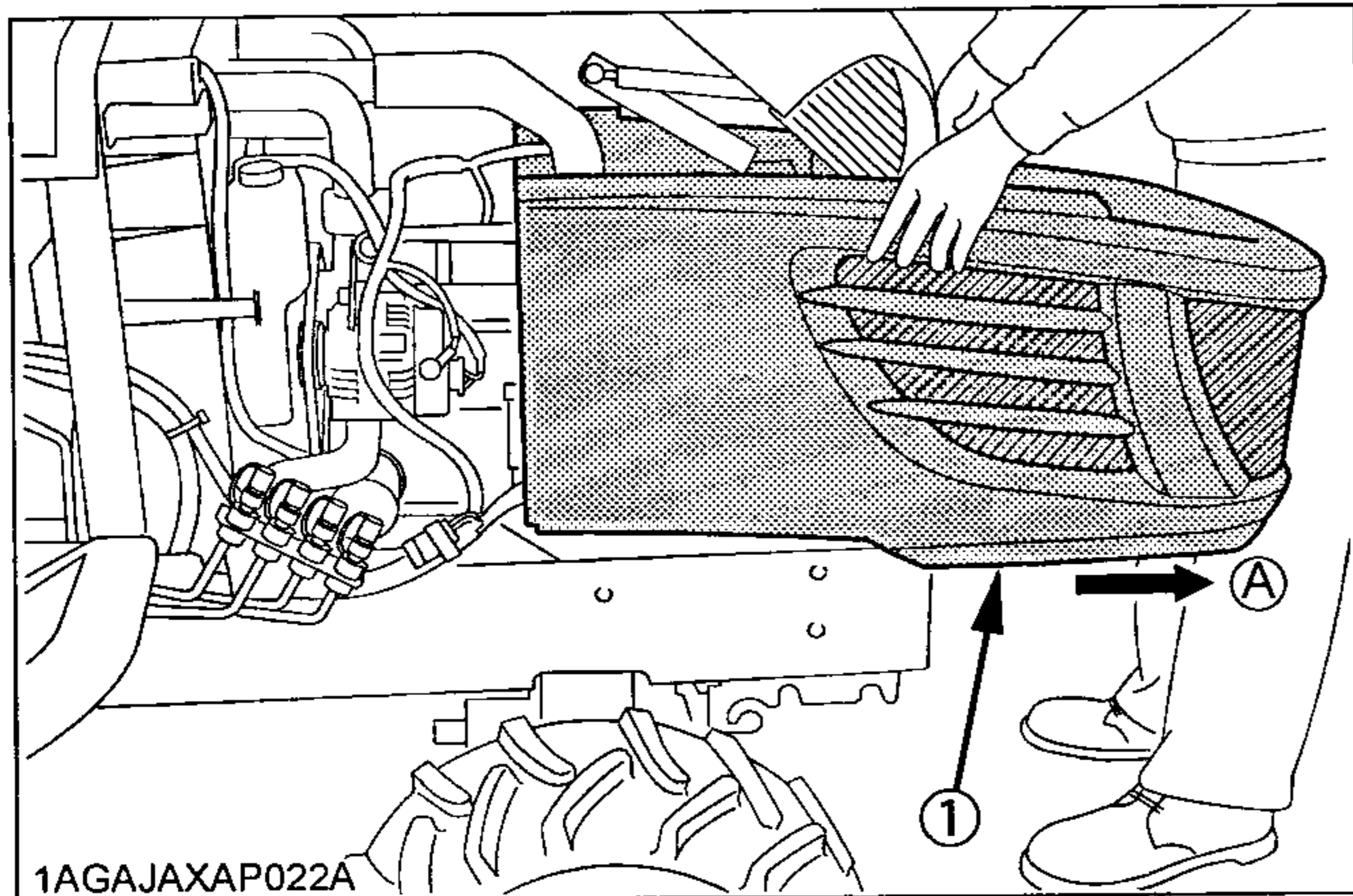

1AGAJAXAP022A

(1) Engine cover

(A) "PULL"

NOTE :

- When reinstall the engine cover, tighten the knob bolts.

DAILY CHECK

For your own safety and maximum service life of the machine, make a thorough daily inspection before operating the machine to start the engine.



CAUTION

To avoid personal injury:

- Be sure to check and service the tractor on a level surface with the engine shut off and the parking brake "ON" and implement lowered to the ground.

■ Walk Around Inspection

Look around and under the tractor for such items as loose bolts, trash build-up, oil or coolant leaks, broken or worn parts.

■ Checking and Refueling



CAUTION

To avoid personal injury:

- Do not smoke while refueling.
- Be sure to stop the engine and remove the key before refueling.

To avoid allergic skin reaction:

- Wash hands immediately after contact with diesel fuel.

1. Turn the key switch to "ON", check the amount of fuel by fuel gauge.
2. Fill fuel tank when fuel gauge shows 1/4 or less fuel in tank.
3. Use grade No.2-Diesel fuel at temperatures above -10 °C (14 °F).
Use grade No.1-Diesel fuel at temperatures below -10 °C (14 °F).

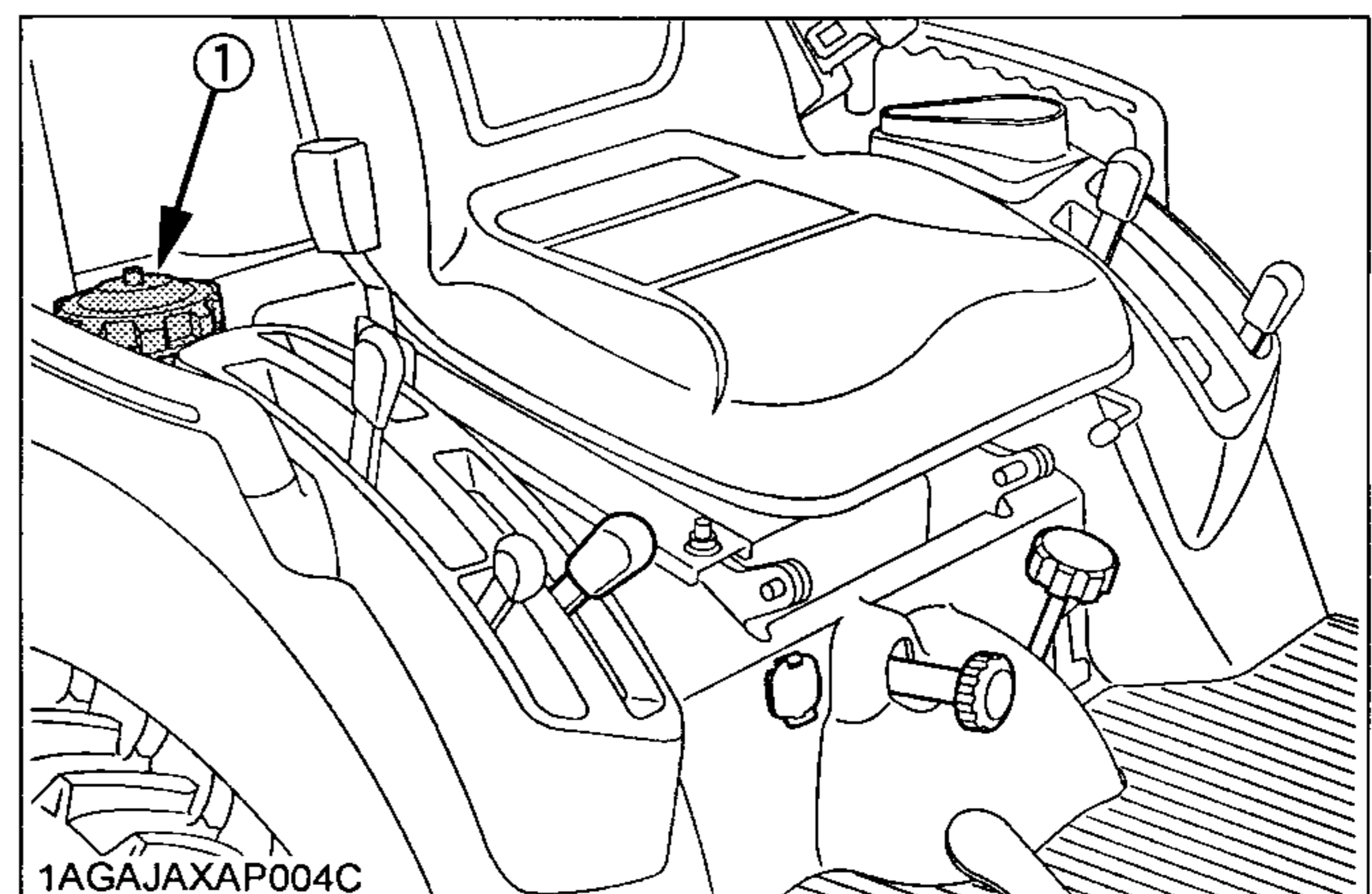

1AGAJAXAP004C

(1) Fuel tank cap

Fuel tank capacity	25L (6.6 U.S.gals.)
--------------------	---------------------

IMPORTANT :

- Do not permit dirt or trash to get into the fuel system.
- Be careful not to let the fuel tank become empty, otherwise air will enter the fuel system, necessitating bleeding before next engine start.
- Be careful not to spill during refueling. If should spill, wipe it off at once, or it may cause a fire.
- To prevent condensation (water) accumulation in the fuel tank, fill the tank before parking overnight.

NOTE :

- No.2-D is a distillate fuel of lower volatility for engines in industrial and heavy mobile service. (SAE J313 JUN87)
- Grade of Diesel Fuel Oil According to ASTM D975

Flash Point, °C (°F)	Water and Sediment, volume %	Carbon Residue on, 10 percent Residuuum, %	Ash, weight %
Min	Max	Max	Max
52 (125)	0.05	0.35	0.01

Distillation Temperatures, °C (°F) 90% Point		Viscosity Kinematic cSt or mm ² /s at 40 °C		Viscosity Saybolt, SUS at 100 °F		Sulfur weight %	Copper Strip Corrosion	Cetane Number
Min	Max	Min	Max	Min	Max	Max	Max	Min
282 (540)	338 (640)	1.9	4.1	32.6	40.1	0.50	No.3	40

Checking Engine Oil Level



CAUTION

To avoid personal injury:

- Be sure to stop the engine before checking the oil level.

1. Park the machine on a flat surface.
2. Check engine oil before starting the engine or 5 minutes or more after the engine has stopped.
3. To check the oil level, draw out the dipstick, wipe it clean, replace it, and draw it out again. Check to see that the oil level lies between the two notches. If the level is too low, add new oil to the prescribed level at the oil inlet.

(See "LUBRICANTS" in Maintenance section)

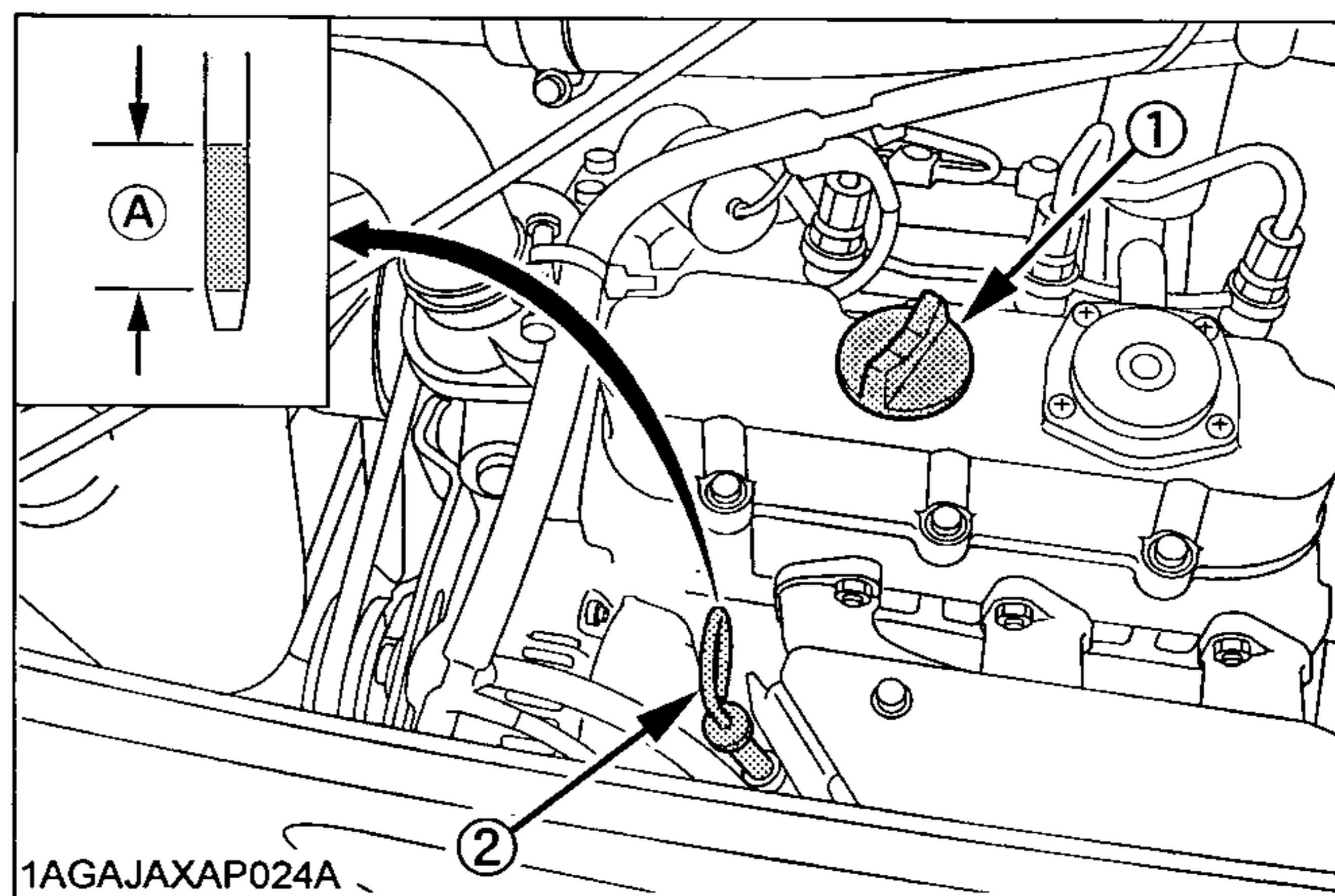

(1) Oil inlet (A) Oil level is acceptable within this range.
(2) Dipstick

IMPORTANT :

- When using an oil of different maker or viscosity from the previous one, remove all of the old oil and oil filter. Never mix two different types of oil.
- If oil level is low, do not run engine.

■ Checking Transmission Fluid Level

1. Park the machine on a flat surface, lower the implement and shut off engine.
2. To check the oil level, draw out the dipstick, wipe it clean, replace it, and draw it out again. Check to see that the oil level lies between the two notches. If the level is too low, add new oil to the prescribed level at the oil inlet.
(See "LUBRICANTS" in Maintenance section)

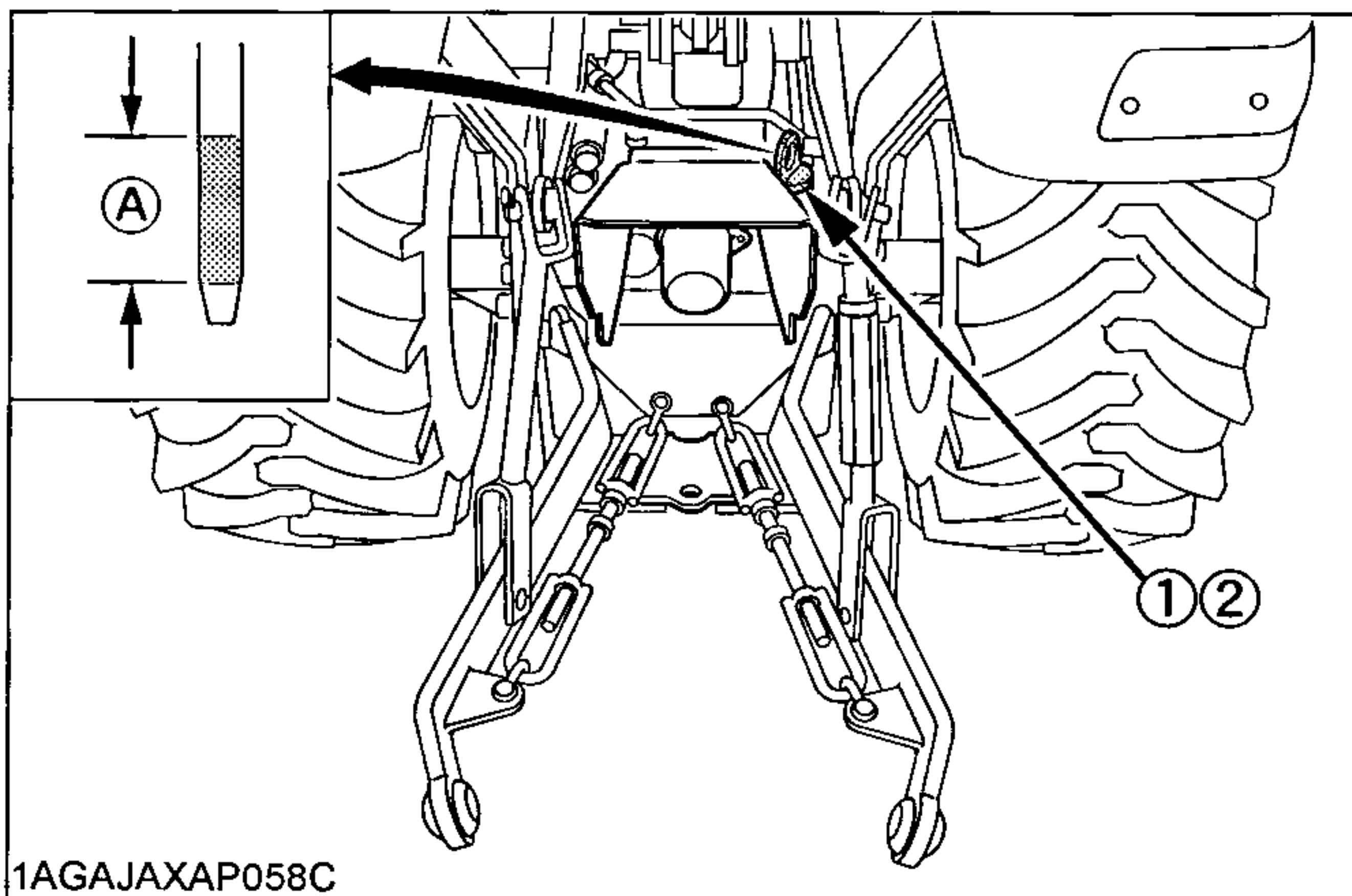

(1) Oil inlet (A) Oil level is acceptable within this range.
(2) Dipstick

IMPORTANT :

- If oil level is low, do not run engine.

■ Checking Coolant Level



CAUTION

To avoid personal injury:

- Be sure to stop the engine and remove the key before checking coolant level.
- Do not remove the radiator cap while coolant is hot. When cool, slowly rotate cap to the first stop and allow sufficient time for excess pressure to escape before removing cap completely.

1. Check to see that the coolant level is between the "H" and "L" marks of recovery tank.
2. When the coolant level drops due to evaporation, add water only. In case of leakage, add antifreeze and water in the specified mixing ratio up to the "H" level.
(See "Flush Cooling System and Changing Coolant" in every 2 years maintenance)

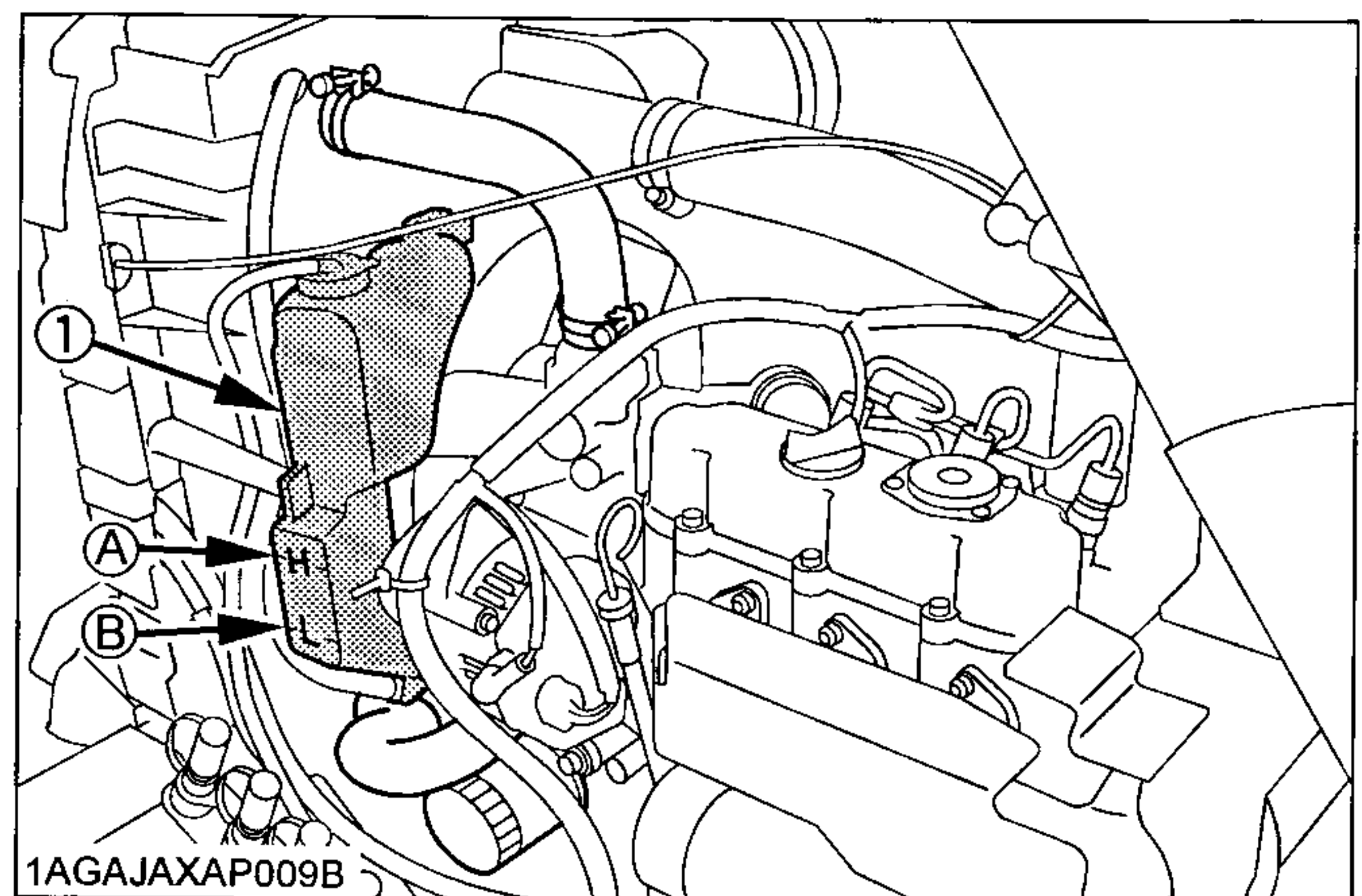

(1) Recovery tank (A) "H"
(B) "L"

IMPORTANT :

- If the radiator cap has to be removed, follow the caution above and securely retighten the cap.
- Use clean, fresh water and anti-freeze to fill the radiator.
- If water should leak, consult your local KUBOTA Dealer.

■ Cleaning Panel and Radiator Screen

CAUTION

To avoid personal injury:

- Be sure to stop the engine and remove the key before removing the screen.

1. Check panel screen to be sure they are clean from debris.
2. Detach the radiator screen, and then remove all the foreign material.

NOTE :

- If the dust or chaff is accumulated in the battery compartment, open the panel and clean completely.

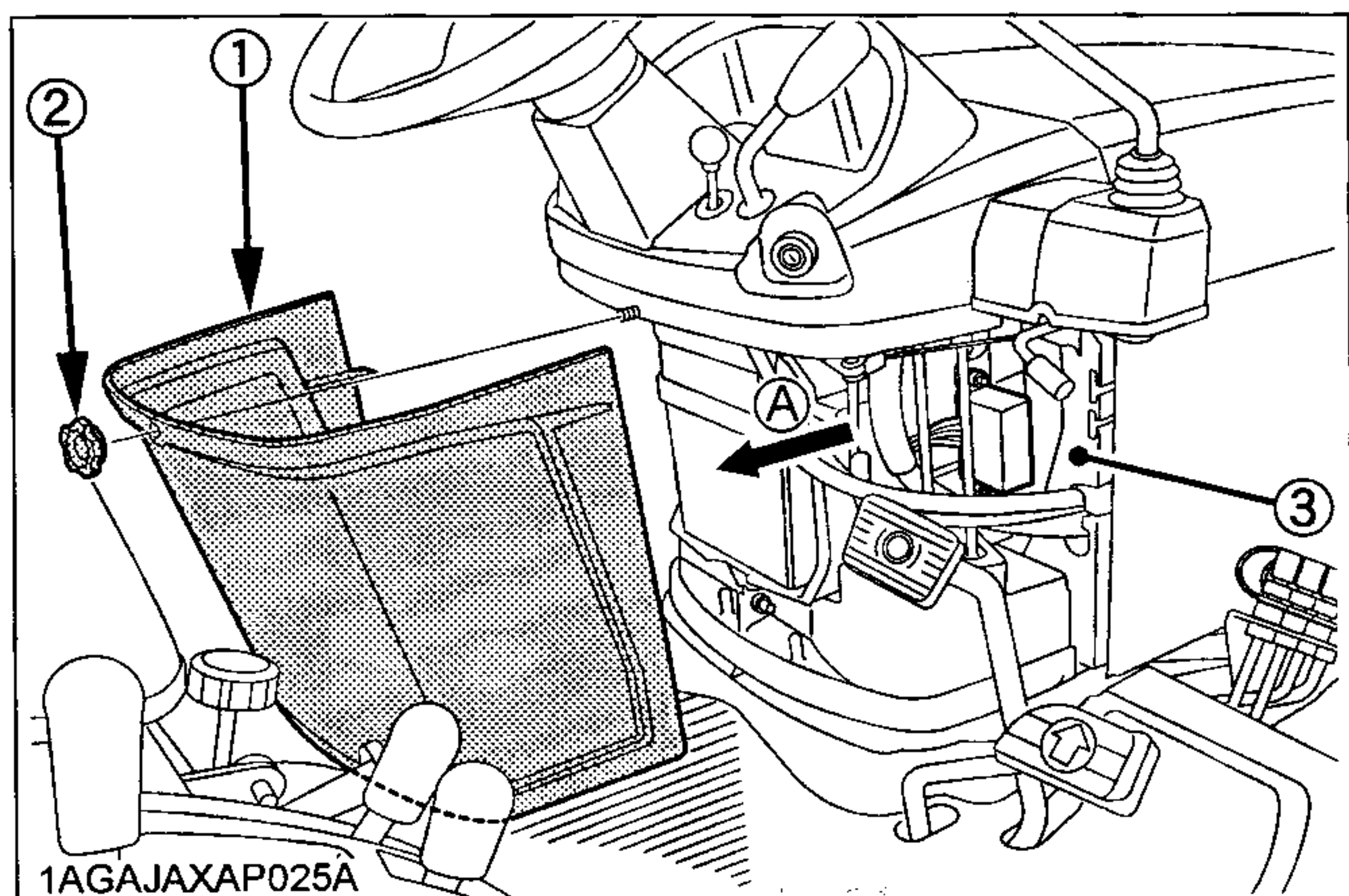

- (1) Panel
(2) Knob
(3) Center pillar

(A) "DETACH"

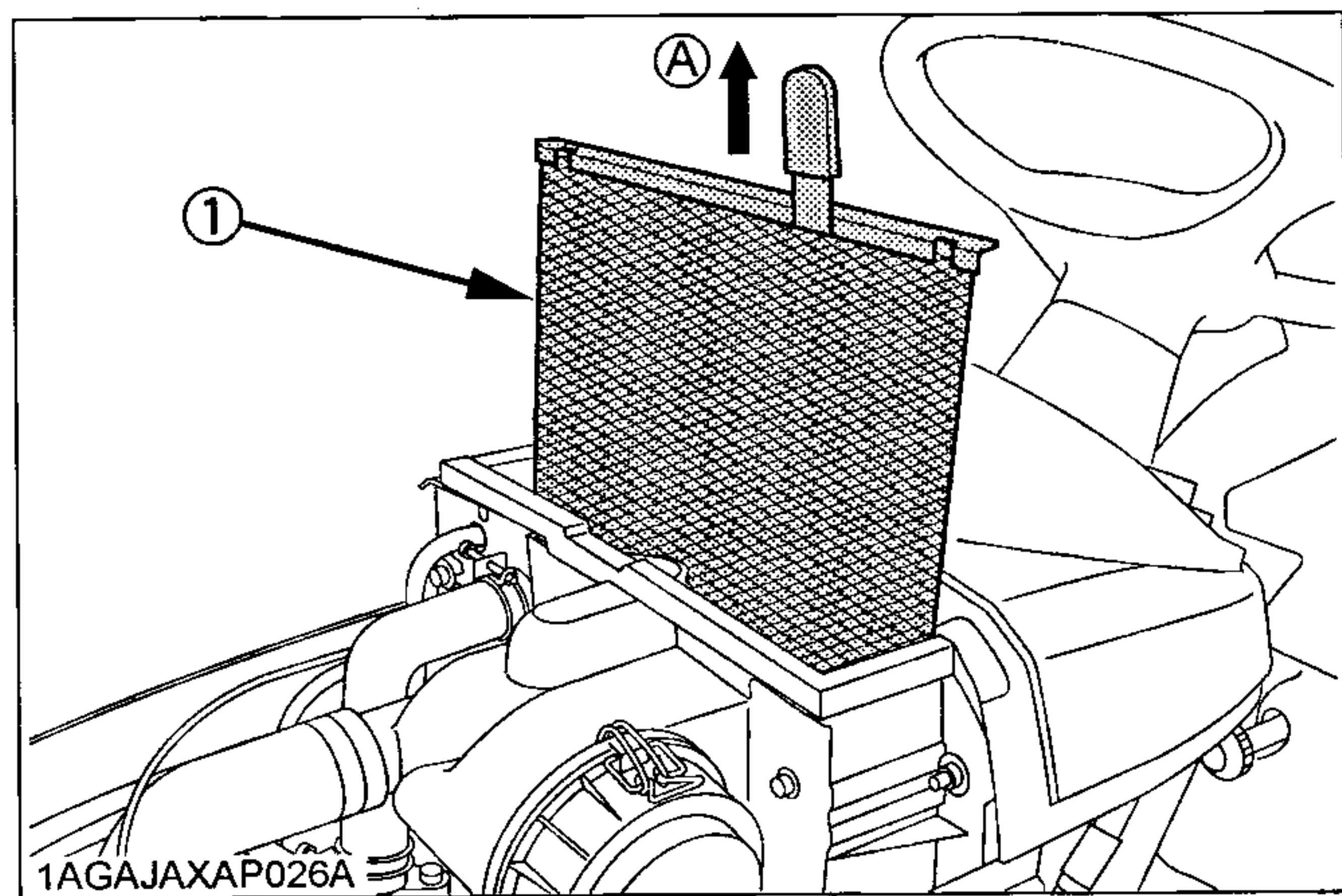

- (1) Radiator screen

(A) "DETACH"

IMPORTANT :

- Panel and radiator screen must be clean from debris to prevent engine from overheating and to allow good air intake for air cleaner.
- Be sure to reinstall the panel on the pillar completely to prevent the invasion of dust.
- Be sure to stop the engine to avoid personal injury and to allow good air intake for air cleaner.

■ Checking Brake Pedal

1. Inspect the brake pedals for free travel, and smooth operation.
2. Adjust if incorrect measurement is found:
(See "Adjusting Brake Pedal" in every 100 hours maintenance.)

■ Checking Gauges, Meter and Easy Checker(TM)

1. Inspect the instrument panel for broken gauge(s), meter(s) and Easy Checker(TM) lamps.
2. Replace if broken.

■ Checking Head Light, Hazard Light etc.

1. Inspect the lights for broken bulbs and lenses.
2. Replace if broken.

■ Checking Seat Belt and ROPS

1. Always check condition of seat belt and ROPS attaching hardware before operating tractor.
2. Replace if damaged.

■ Checking and Cleaning of Electrical Wiring and Battery Cables



CAUTION

To avoid personal injury:

- A loosened terminal or connector, or damaged wire may affect the performance of electrical components or cause short circuits. Leakage of electricity could result in a fire hazard, a dead battery or damage to electrical components.
- Replace damaged wires or connections promptly.
- If a fuse blows soon after replacement, **DO NOT USE A LARGER THAN RECOMMENDED FUSE OR BYPASS THE FUSE SYSTEM.**
- Many wiring connections are protected by waterproof plugs, plug and unplug these connections carefully and make sure they are sealed correctly after assembly.
- Accumulation of dust, chaff or spilled fuel deposits around the battery, electrical wiring, engine or exhaust system are a fire hazard. **CLEAN THESE AREAS BEFORE STARTING WORK.**

To avoid premature electrical malfunctions **DO NOT APPLY** high pressure water directly to battery, wiring, connectors, electrical components or instrument panel.

Inspect the following Regularly:

1. Check wiring for chafed or cracked insulation.
2. Check wiring harness clamps. Replace if necessary.
3. Check connectors and terminals for looseness, contamination or overheated (discolored) connections.
4. Check instrument panel for correct operation of switches and gauges.

Consult your Kubota Dealer regarding maintenance, diagnosis and repair.

EVERY 50 HOURS

■ Lubricating Grease Fittings

Apply a small amount of multipurpose grease to the following points every 50 hours:

If you operated the machine in extremely wet and muddy conditions, lubricate grease fittings more often.

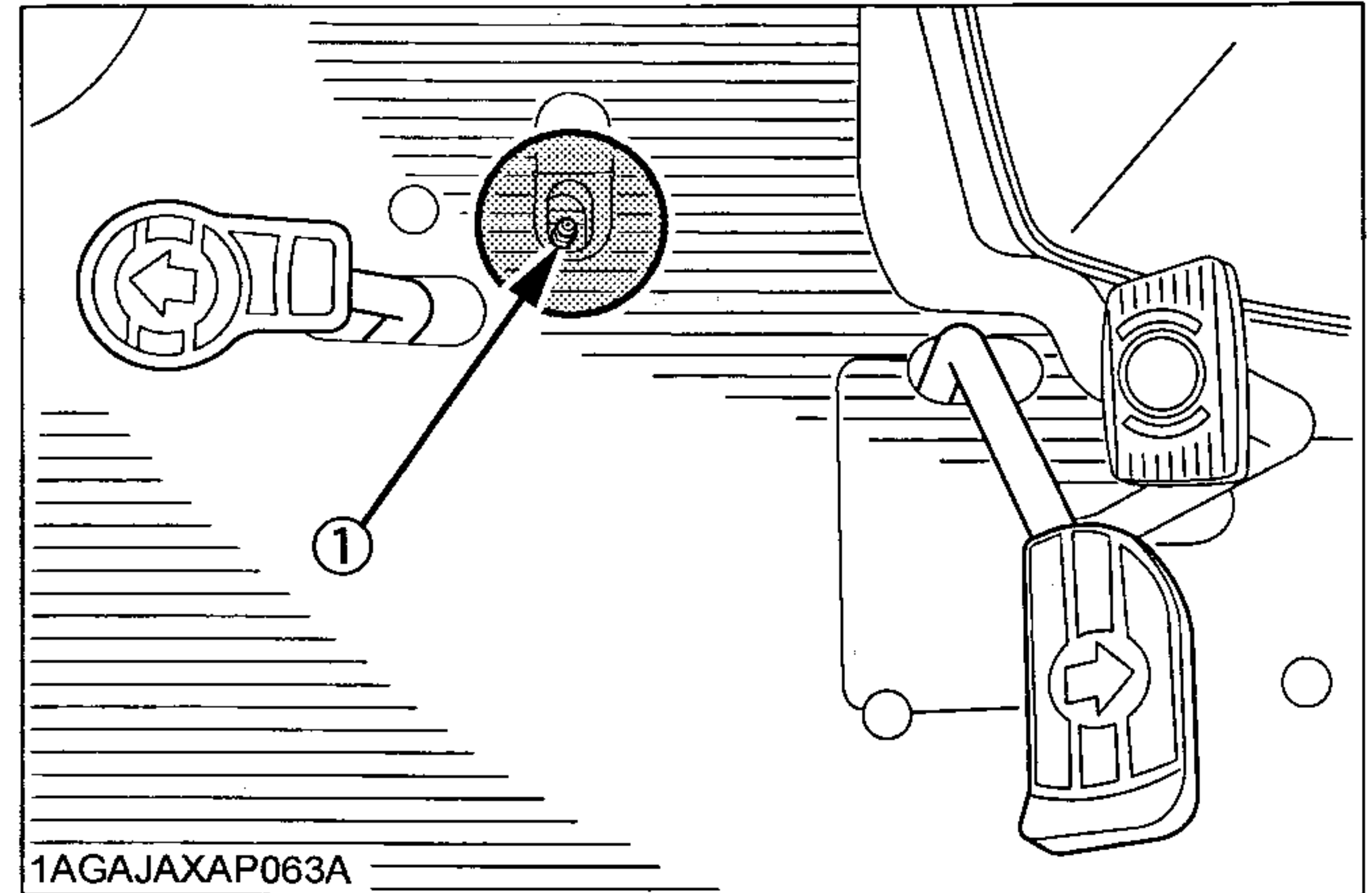

1AGAJAXAP063A

(1) Grease fitting (Speed control pedal)

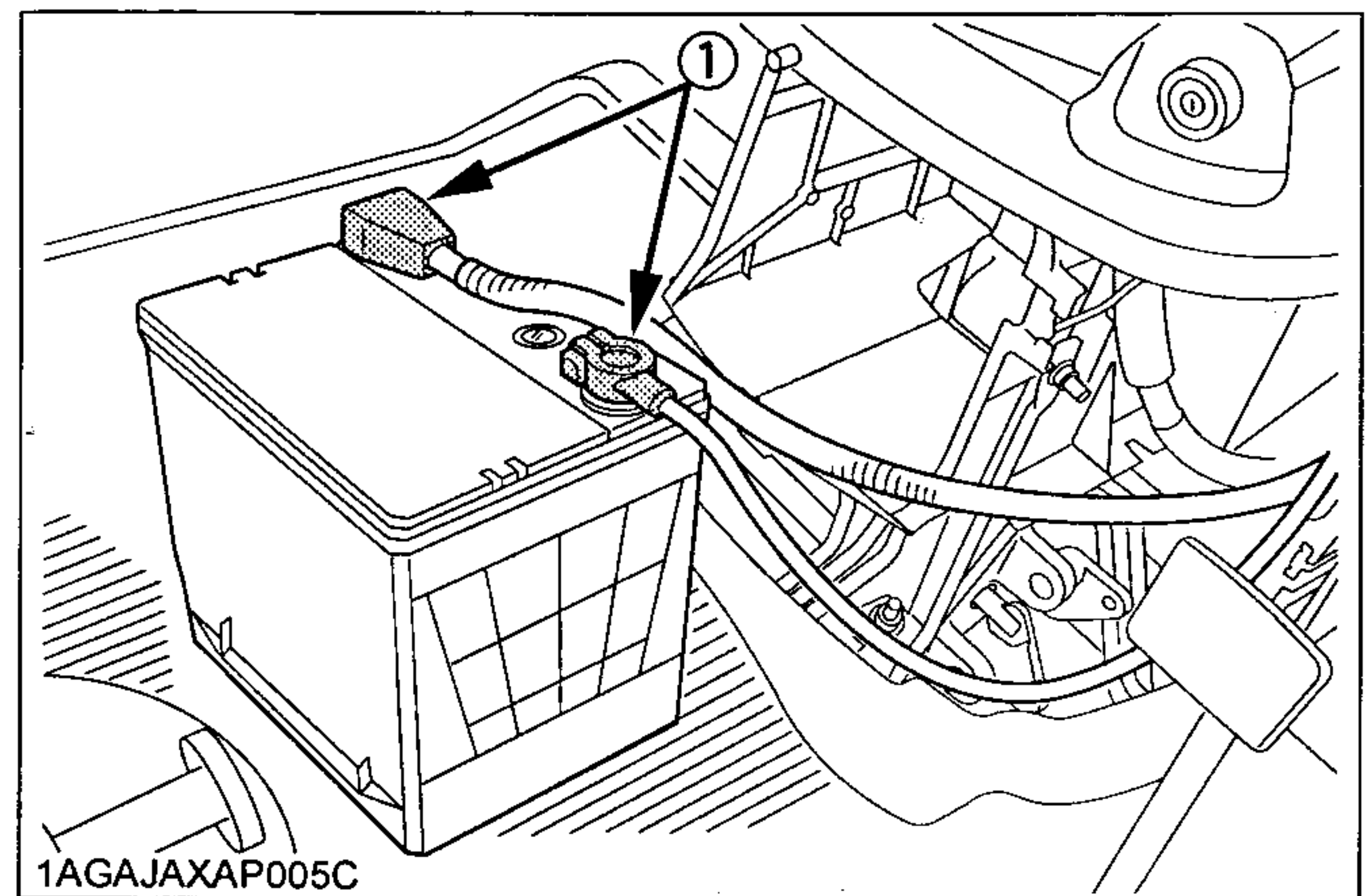

1AGAJAXAP005C

(1) Battery terminals

■ Checking Engine Start System



CAUTION

To avoid personal injury:

- Do not allow anyone near the tractor while testing.
- If the tractor does not pass the test do not operate the tractor.

◆ Preparation before testing.

1. Sit on operator's seat.
2. Set the parking brake and stop the engine.
3. Shift the range gear shift lever to "NEUTRAL" position.
4. Check the speed control pedal "NEUTRAL" position.
5. Shift the PTO clutch lever to "OFF" position.

◆ Test 1: Switch for the speed control pedal

1. Shift the range gear shift lever to "NEUTRAL" position.
2. Depress the speed control pedal.
3. Turn the key to "START" position.
4. The engine must not crank.
5. If it cranks, consult your local KUBOTA Dealer for this service.

◆ Test 2: Switch for the PTO clutch lever

1. Shift the range gear shift lever to "NEUTRAL" position.
2. Check the speed control pedal "NEUTRAL" position.
3. Shift the PTO clutch lever to "ON" position.
4. Turn the key to "START" position.
5. The engine must not crank.
6. If it cranks, consult your local KUBOTA Dealer for this service.

◆ Test 3: Switches for the operator's seat and the speed control pedal

1. Sit on the operator's seat.
2. Shift the range gear shift lever to "NEUTRAL" position.
3. Start the engine.
4. Depress the speed control pedal.
5. Stand up. (Do not get off the machine.)
6. The engine must shut off after approximately 1 second.
7. If it does not stop, consult your local KUBOTA Dealer for this service.

◆ Test 4 : Switches for the operator's seat and the PTO clutch lever.

1. Sit on the operator's seat.
2. Start the engine.
3. Engage the PTO clutch lever.
4. Stand up. (Do not get off the machine.)
5. The engine must shut off after approximately 1 second.
6. If it does not stop, consult your local KUBOTA Dealer for this service.

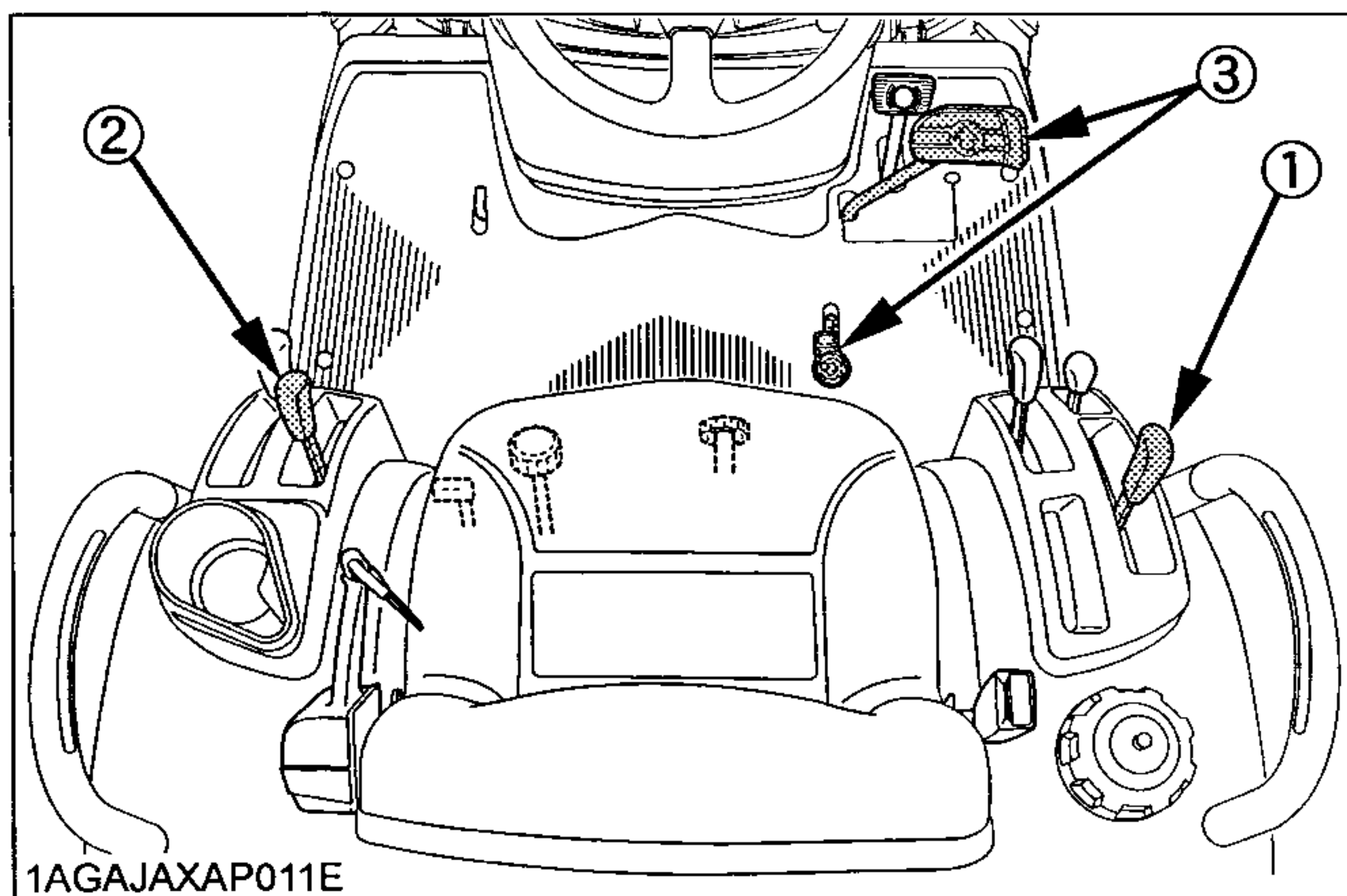

- (1) Range gear shift lever (Hi-Lo)
 (2) PTO clutch control lever
 (3) Speed control pedal

■ Checking Wheel Bolt Torque

CAUTION

To avoid personal injury:

- Never operate tractor with a loose rim, wheel, or axle.
- Any time bolts are loosened, retighten to specified torque.
- Check all bolts frequently and keep them tight.

Check wheel bolts regularly especially when new. If they are loose, tighten them as follows.

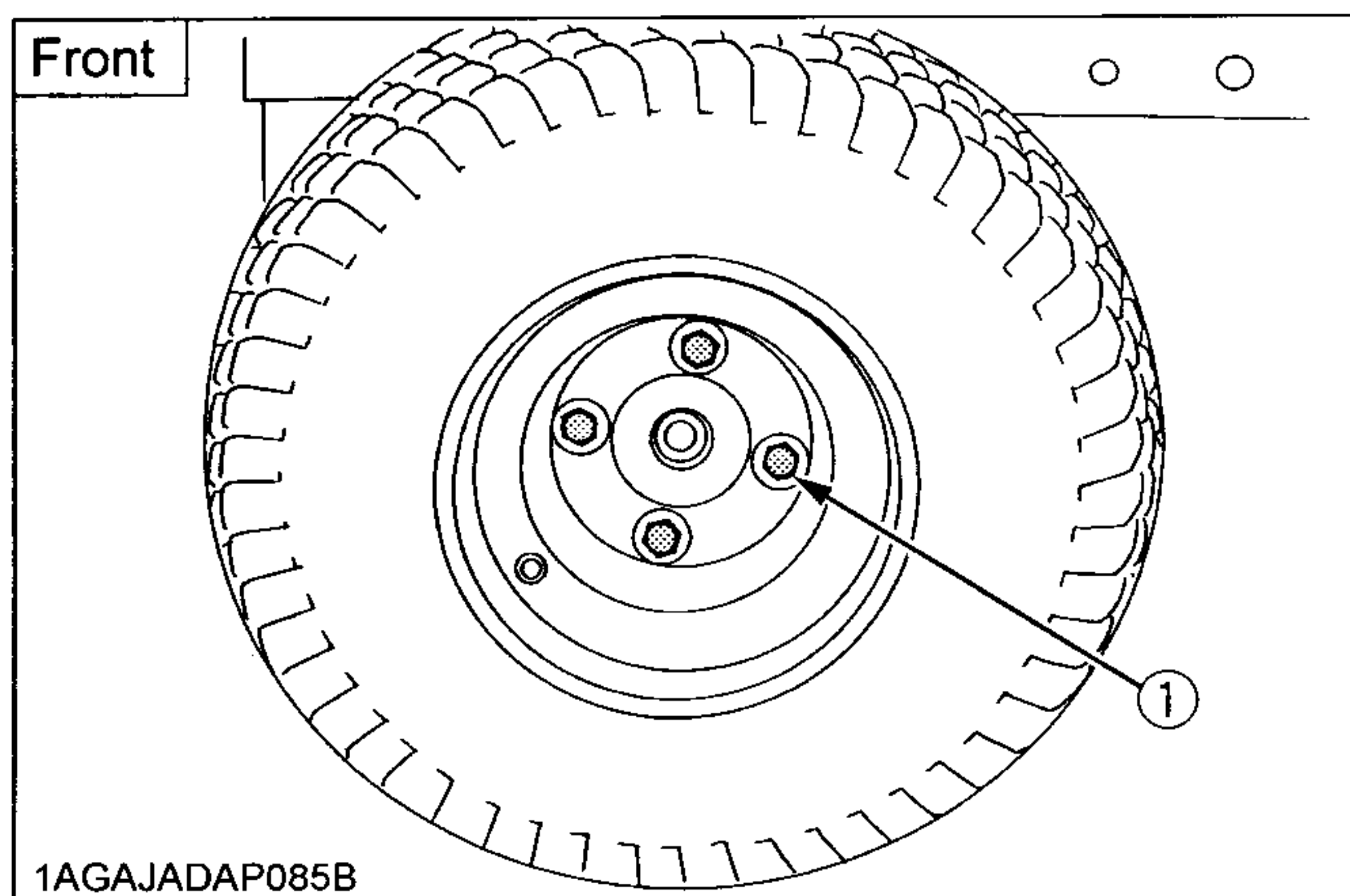

(1) 149.2 to 179.0 N-m (15.2 to 18.3 kgf-m, 110 to 132 ft-lbs.)

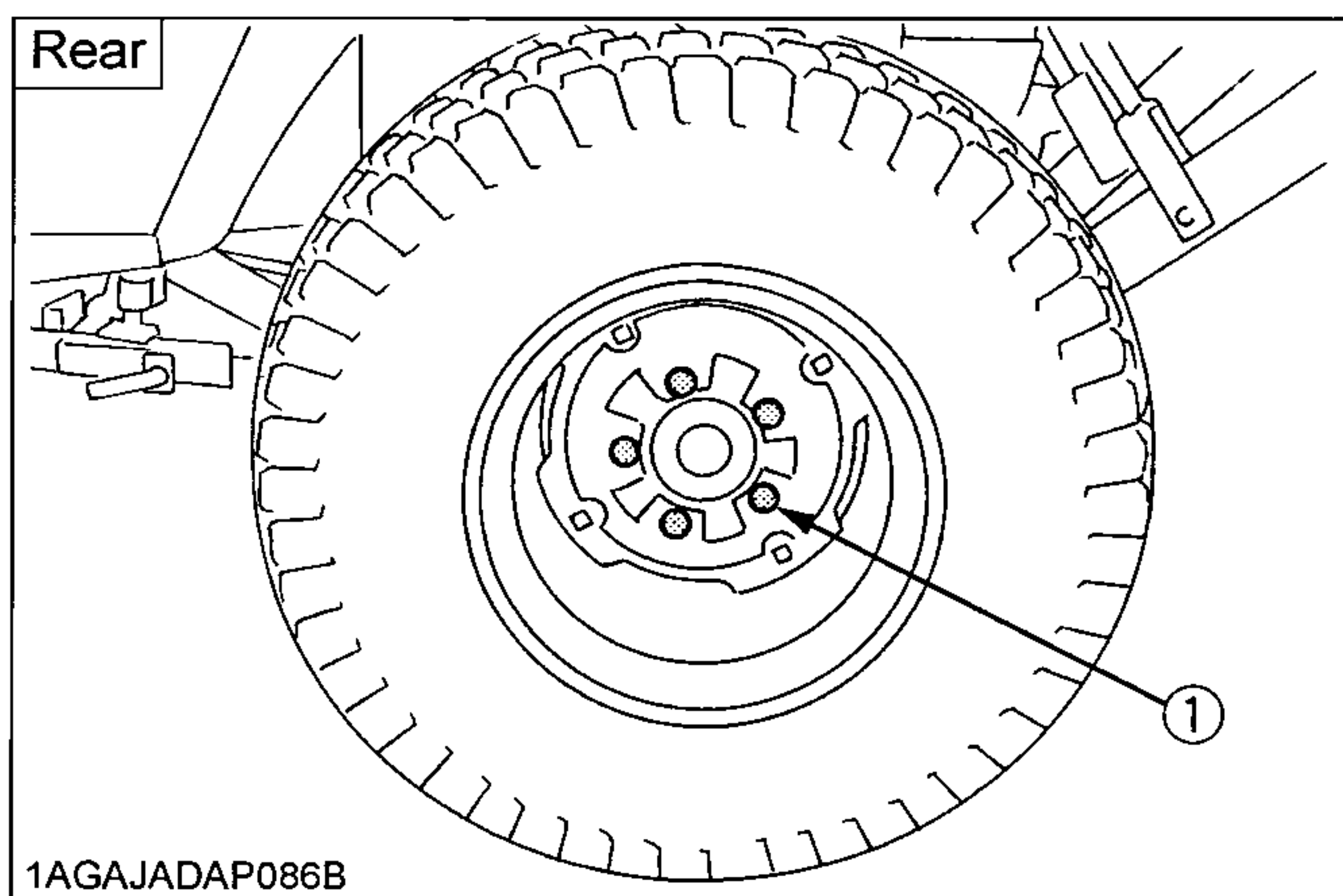

(1) 108.5 to 130.2 N-m (11.1 to 13.3 kgf-m, 80 to 96 ft-lbs.)

EVERY 100 HOURS

■ Battery

DANGER

To avoid the possibility of battery explosion:

For the refillable type battery, follow the instructions below.

- Do not use or charge the refillable type battery if the fluid level is below the LOWER (lower limit level) mark. Otherwise, the battery component parts may prematurely deteriorate, which may shorten the battery's service life or cause an explosion. Check the fluid level regularly and add distilled water as required so that the fluid level is between the UPPER and LOWER levels.

CAUTION

To avoid personal injury:

- Never remove the vent caps while the engine is running.
- Keep electrolyte away from eyes, hands and clothes. If you are spattered with it, wash it away completely with water immediately and get medical attention.
- Wear eye protection and rubber gloves when working around the battery.

Mishandling the battery shortens the service life and adds to maintenance costs.

The original battery is maintenance free, but needs some servicing.

If the battery is weak, the engine will be difficult to start and the lights will be dim. It is important to check the battery periodically.

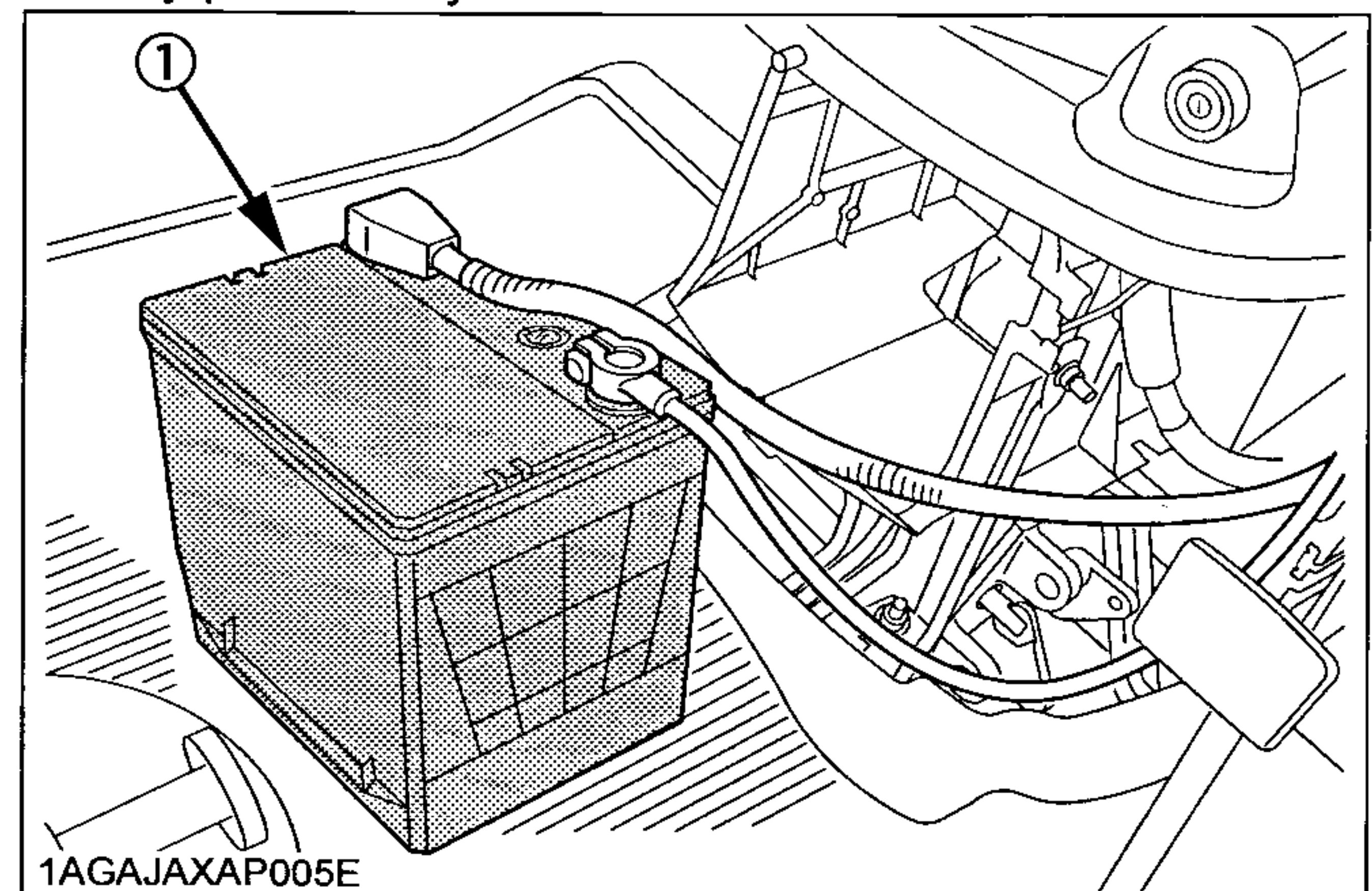

(1) Battery

◆ Battery Charging

CAUTION

To avoid personal injury:

- When the battery is being activated, hydrogen and oxygen gases in the battery are extremely explosive. Keep open sparks and flames away from the battery at all times, especially when charging the battery.
- When charging the battery, ensure the vent caps are securely in place. (if equipped)
- When disconnecting the cable from the battery, start with the negative terminal first.
- When connecting the cable to the battery, start with the positive terminal first.
- Never check battery charge by placing a metal object across the posts.
Use a voltmeter or hydrometer.
(For accessible maintainable type batteries with removable vent caps.)

1. Make sure each electrolyte level is to the bottom of vent wells, if necessary add distilled water in a well-ventilated area.

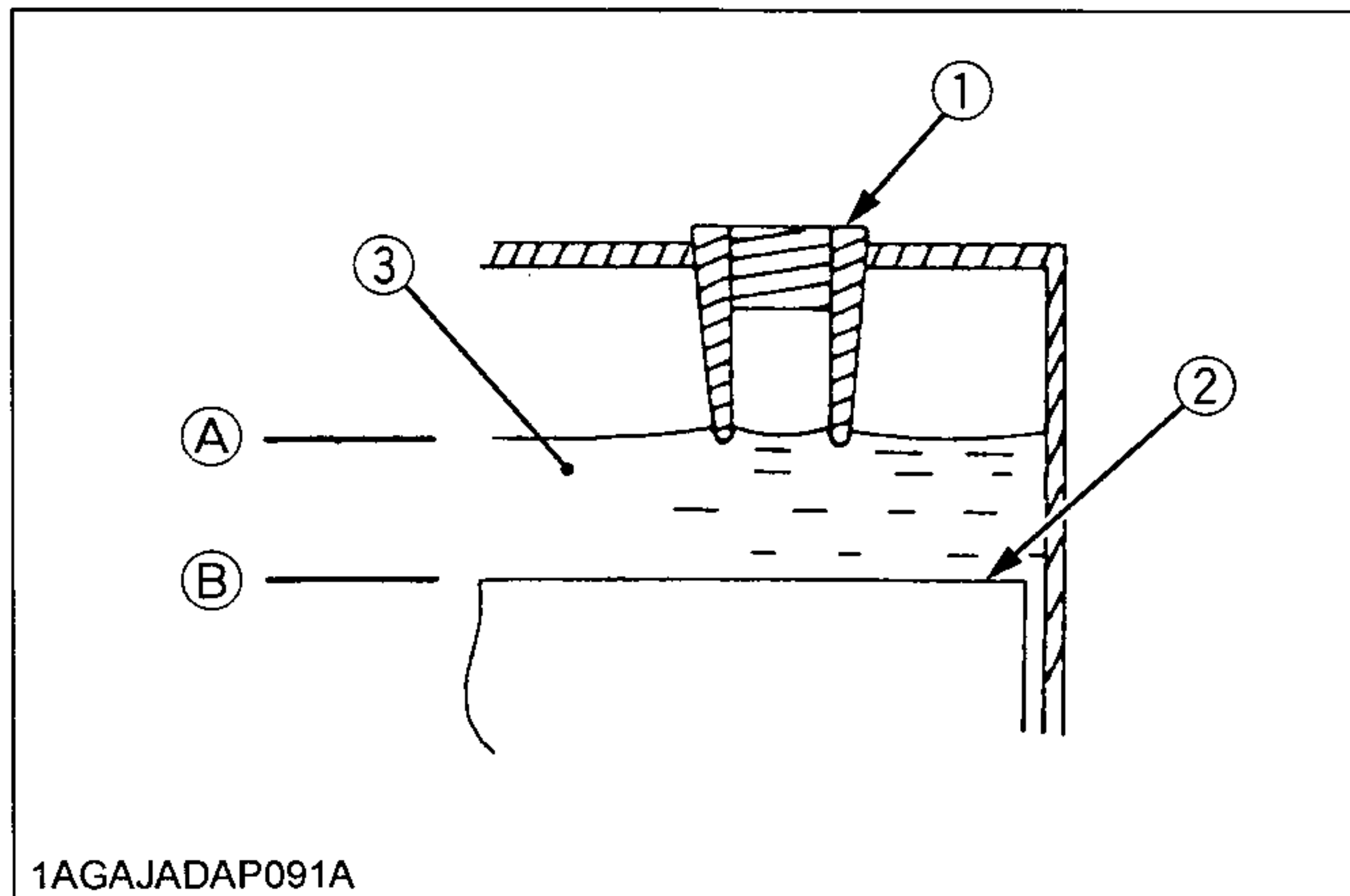

1AGAJADAP091A

- (1) Vent well
- (2) Separator
- (3) Electrolyte
- (A) Highest level
- (B) Lowest level

2. The water in the electrolyte evaporates during recharging. Liquid shortage damages the battery. Excessive liquid spills over and damages the tractor body.
3. To slow charge the battery, connect the battery positive terminal to the charger positive terminal and the negative to the negative, then recharge in the standard fashion.
4. A boost charge is only for emergencies. It will partially charge the battery at a high rate and in a short time. When using a boost-charged battery, it is necessary to recharge the battery as early as possible. Failure to do this will shorten the battery's service life.
5. When the specific gravity of electrolyte is between 1.27 and 1.29 the charging is completed.
6. When exchanging an old battery for a new one, use battery of equal specification shown in Table 1.

Table 1

Tractor Type	Battery Type	Volts (V)	Reserve Capacity (min)	Cold cranking Amps
BX1850	26/26R	12	62	435
BX2350	526RA	12	80	535

◆ Battery for storage

1. When storing the tractor for a long period, remove the battery from tractor, adjust the electrolyte to the proper level and store in a dry place out of direct sunlight.
2. The battery self-discharges while it is stored. Recharge it once every three months in hot seasons and once every six months in cold seasons.
3. (For non-accessible maintenance-free type batteries.) Maintenance-free, non-accessible batteries are designed to eliminate the need to add water. Yet the volume of electrolyte above plates may eventually become depleted due to abnormal conditions such as high heat or improper regulator setting. Use a voltmeter to check the state of charge. (See reference chart below to determine if charging is necessary.)

Battery voltage	Reference state of charge
12.6	100%(Full charge)
12.4	75%
12.2	50%
12.0	25%
11.8	0%

■ Changing Engine Oil

CAUTION

To avoid personal injury:

- Be sure to stop the engine and remove the key before changing the oil.
- Allow engine to cool down sufficiently, oil can be hot and can burn.

1. To drain the used oil, remove the drain plug at the bottom of the engine and drain the oil completely into the oil pan.
All the used oil can be drained out easily when the engine is still warm.
2. After draining reinstall the drain plug.
3. Fill with the new oil up to the upper notch on the dipstick.
(See "LUBRICANTS" in Maintenance section)
4. Properly dispose of used oil.

Oil capacity with filter	BX1850	2.9 L (3.06 U.S.qts.)
	BX2350	3.1 L (3.3 U.S.qts.)

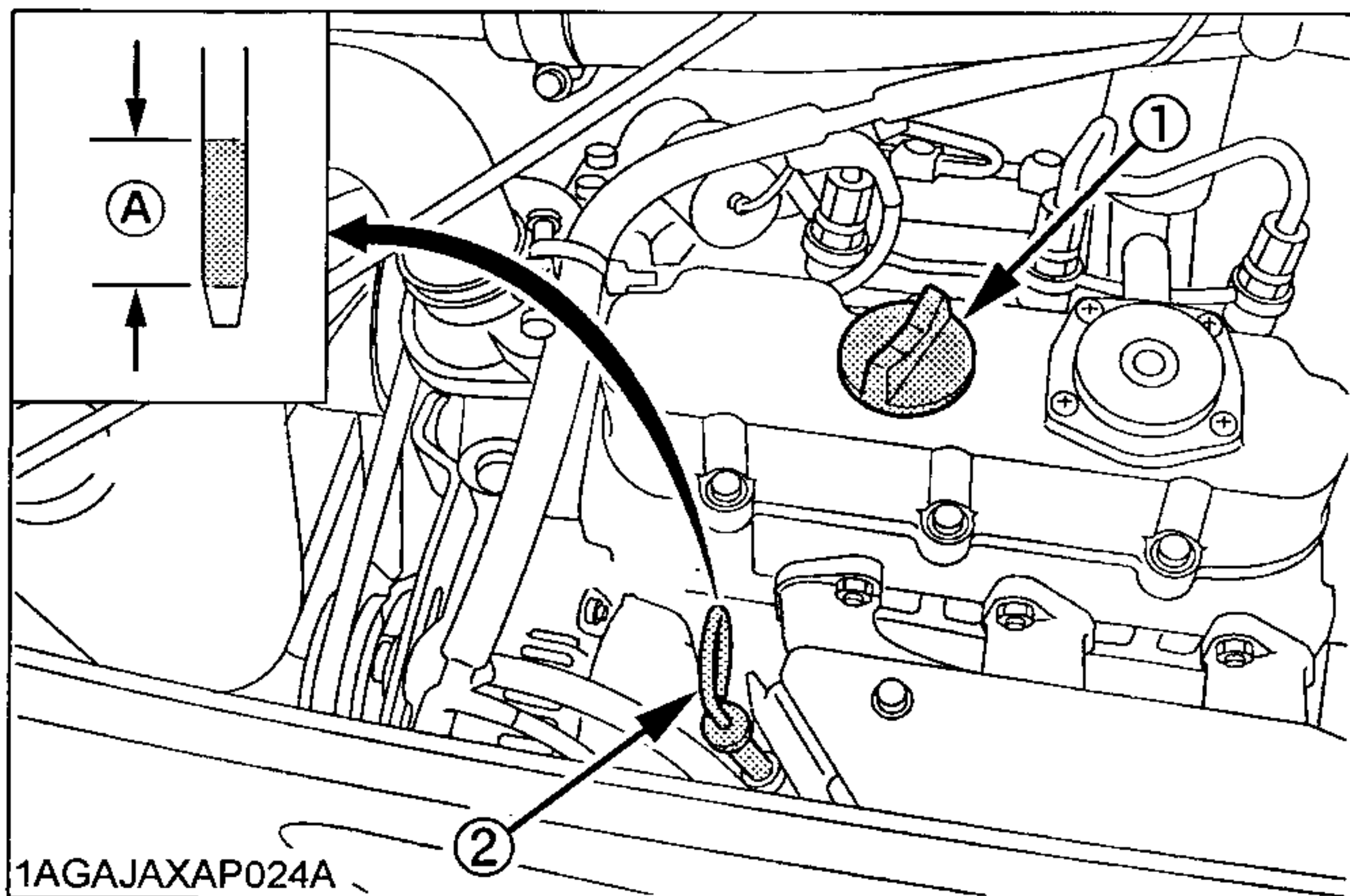

(1) Oil inlet (A) Oil level is acceptable within this range
(2) Dipstick

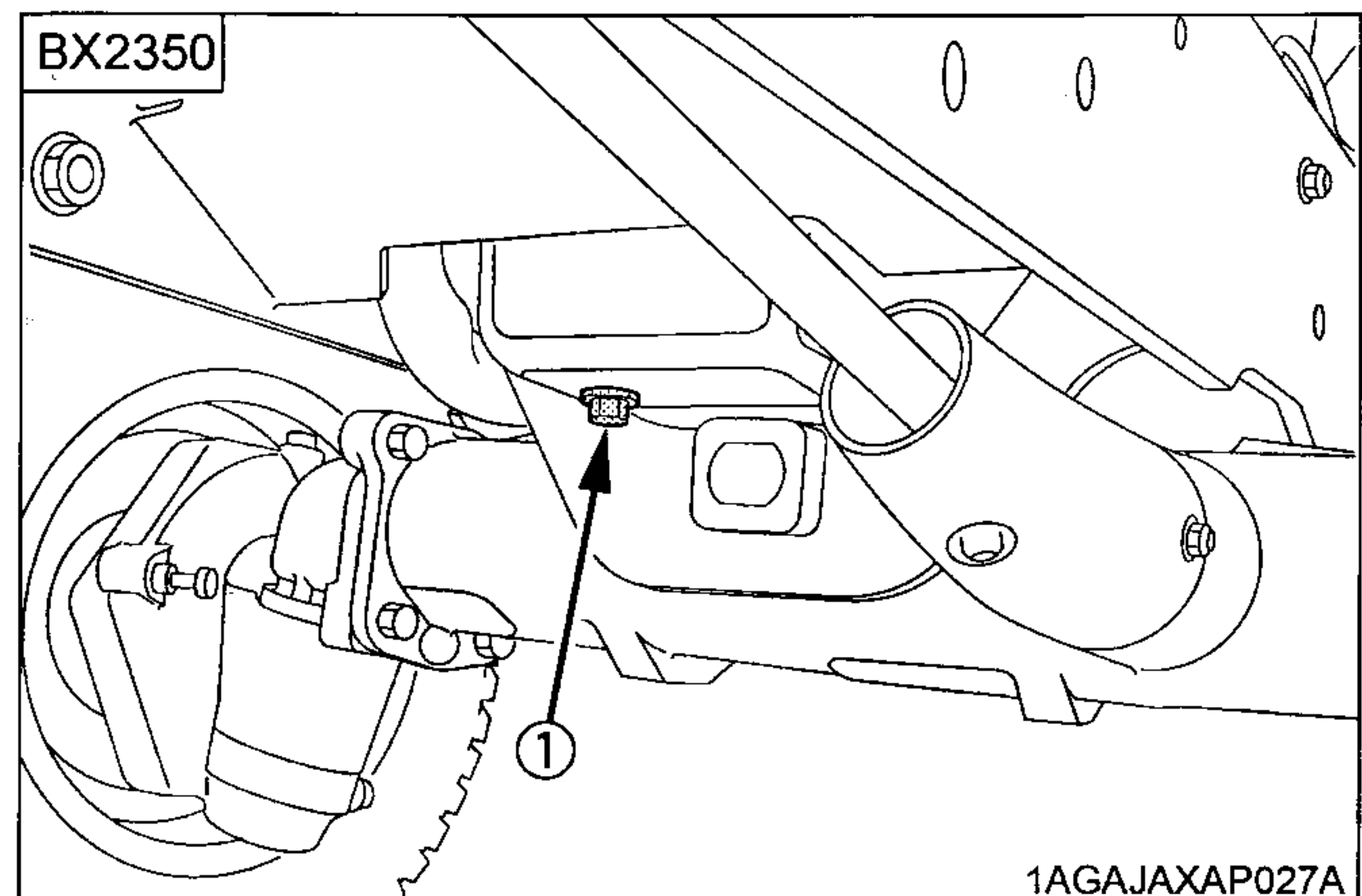
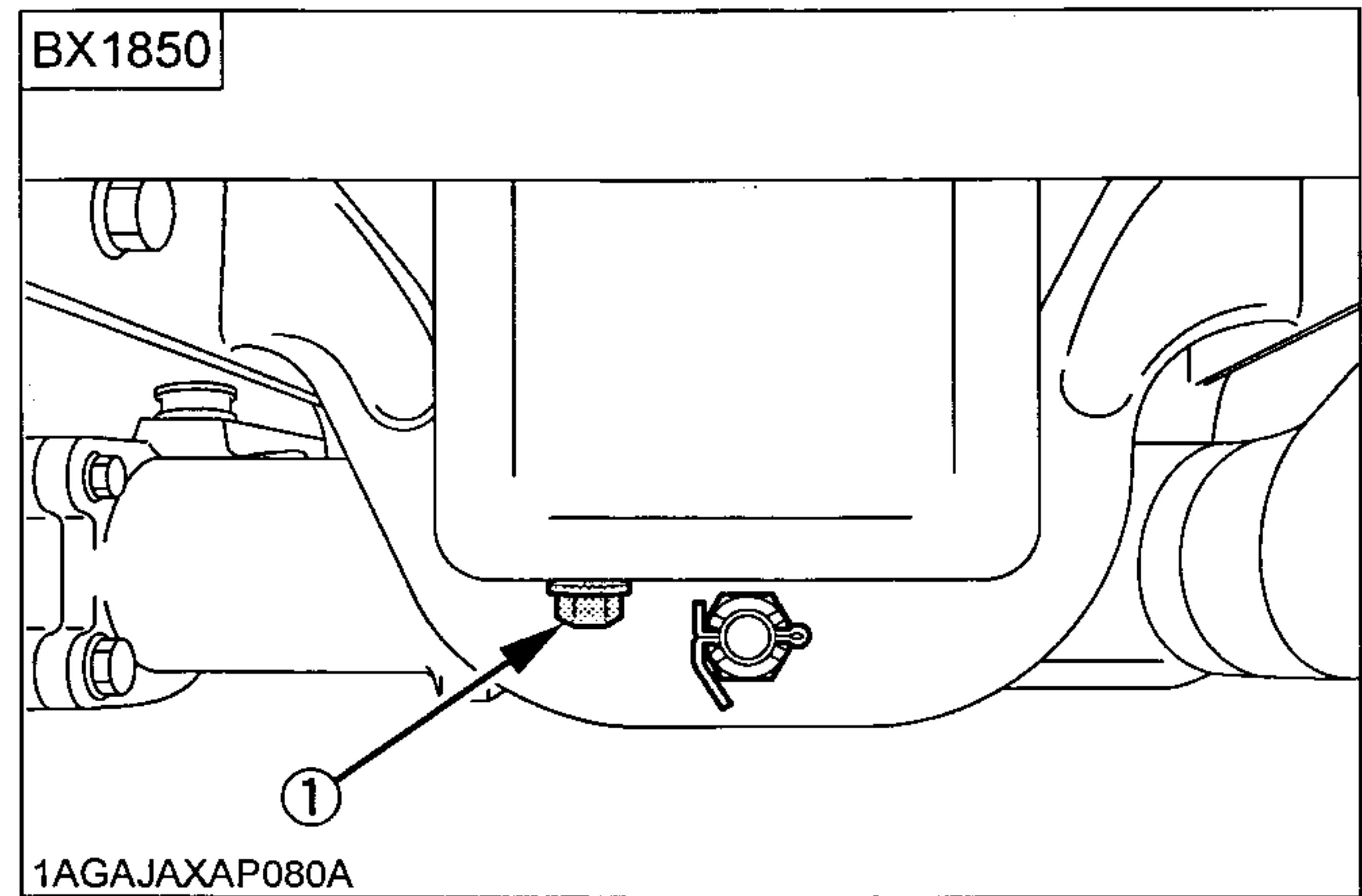

(1) Drain plug

■ Cleaning Air Cleaner Element



CAUTION

To avoid personal injury:

- Be sure to stop the engine and remove the key before cleaning air cleaner element.

1. Remove the air cleaner cover and the element.
 - (1) Undo the hook.
 - (2) Turn the cover clockwise and detach it.
2. Clean the element:
 - (1) When dry dust adheres to the element, blow compressed air from the inside, turning the element. Pressure of compressed air must be under 205kPa (2.1kgf/cm², 30psi).
 - (2) When carbon or oil adheres to the element, soak the element in detergent for 15 minutes then wash it several times in water, rinse with clean water and dry it naturally. After element is fully dried, inspect inside of the element with a light and check if it is damaged or not. (referring to the instructions on the label attached to the case.)
3. Replace air cleaner element:

Once yearly or after every sixth cleaning, whichever comes first.

NOTE :

- Checked to see if the evacuator valve is blocked with dust.

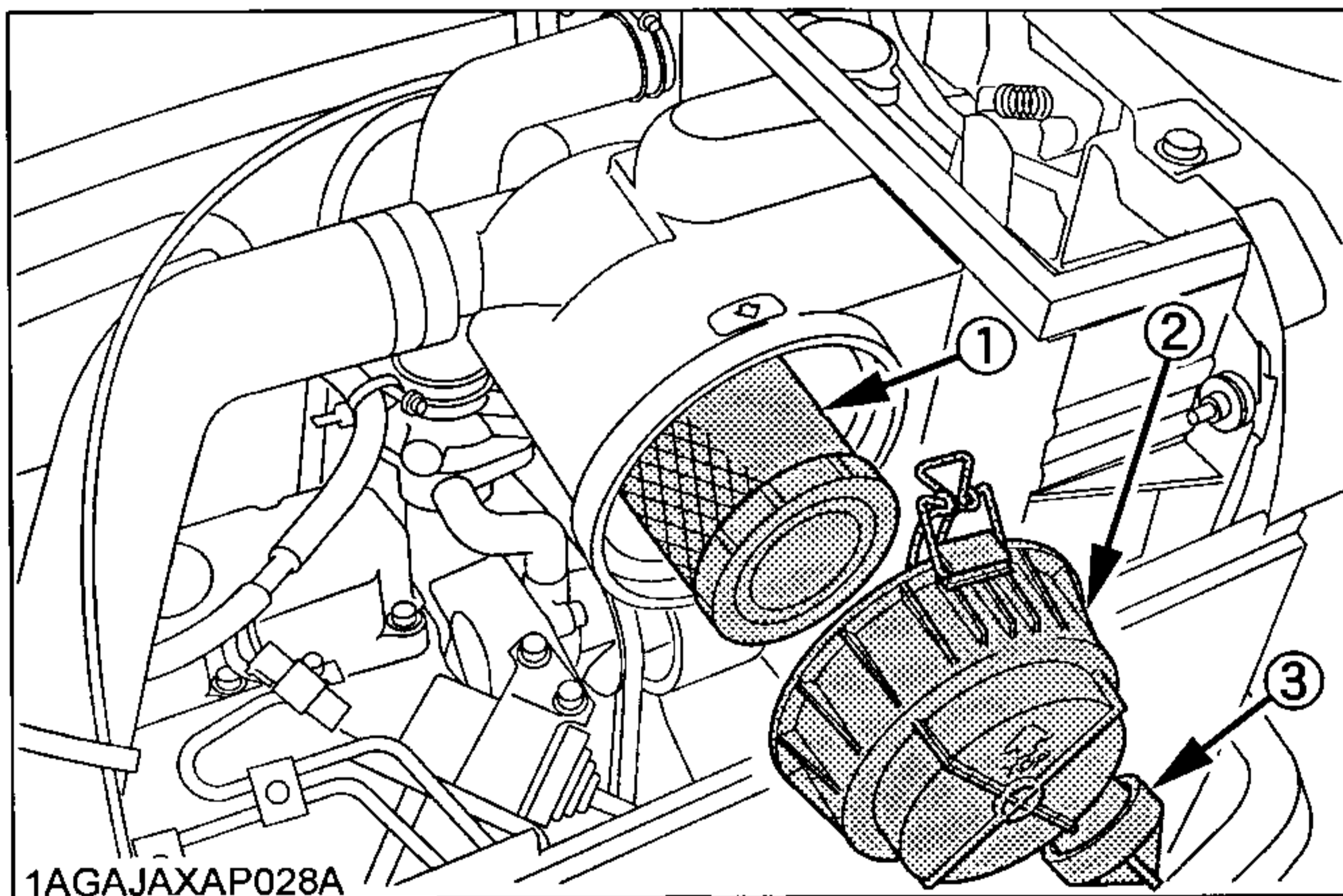

- 1AGA JAXAP028A
- (1) Element
 - (2) Cover
 - (3) Evacuator valve

IMPORTANT :

- The air cleaner uses a dry element, never apply oil.
- Do not run the engine with filter element removed.
- Align the arrow marks when reinstalling the cover. If the cover is improperly fitted, dust passes by the baffle and directly adheres to the element.

◆ Evacuator Valve

Open the evacuator valve once a week under ordinary conditions - or daily when used in a dusty place - to get rid of large particles of dust and dirt.

■ Checking Fuel Lines and Fuel Filter



CAUTION

To avoid personal injury:

- Stop the engine and remove the key before checking fuel lines and fuel filter.
- Check the fuel lines periodically. The fuel lines are subject to wear and aging. Fuel may leak out onto the running engine, causing a fire.

The fuel line connections should be checked annually or every 100 service hours, whichever occurs first.

1. The fuel line is made of rubber and ages regardless of service period.
2. After inspection, if the fuel line and clamps are found damaged or deteriorated, replace them.
3. Check fuel filter, if it is clogged by debris or contaminated by water, replace it.

IMPORTANT :

- When the fuel line is disconnected for maintenance or repair, plug both ends of the fuel line with a clean plug of suitable size to prevent dust and dirt from entering. Particular care must be taken not to admit dust and dirt into the fuel system. Entrance of dust and dirt causes malfunction of the fuel pump.

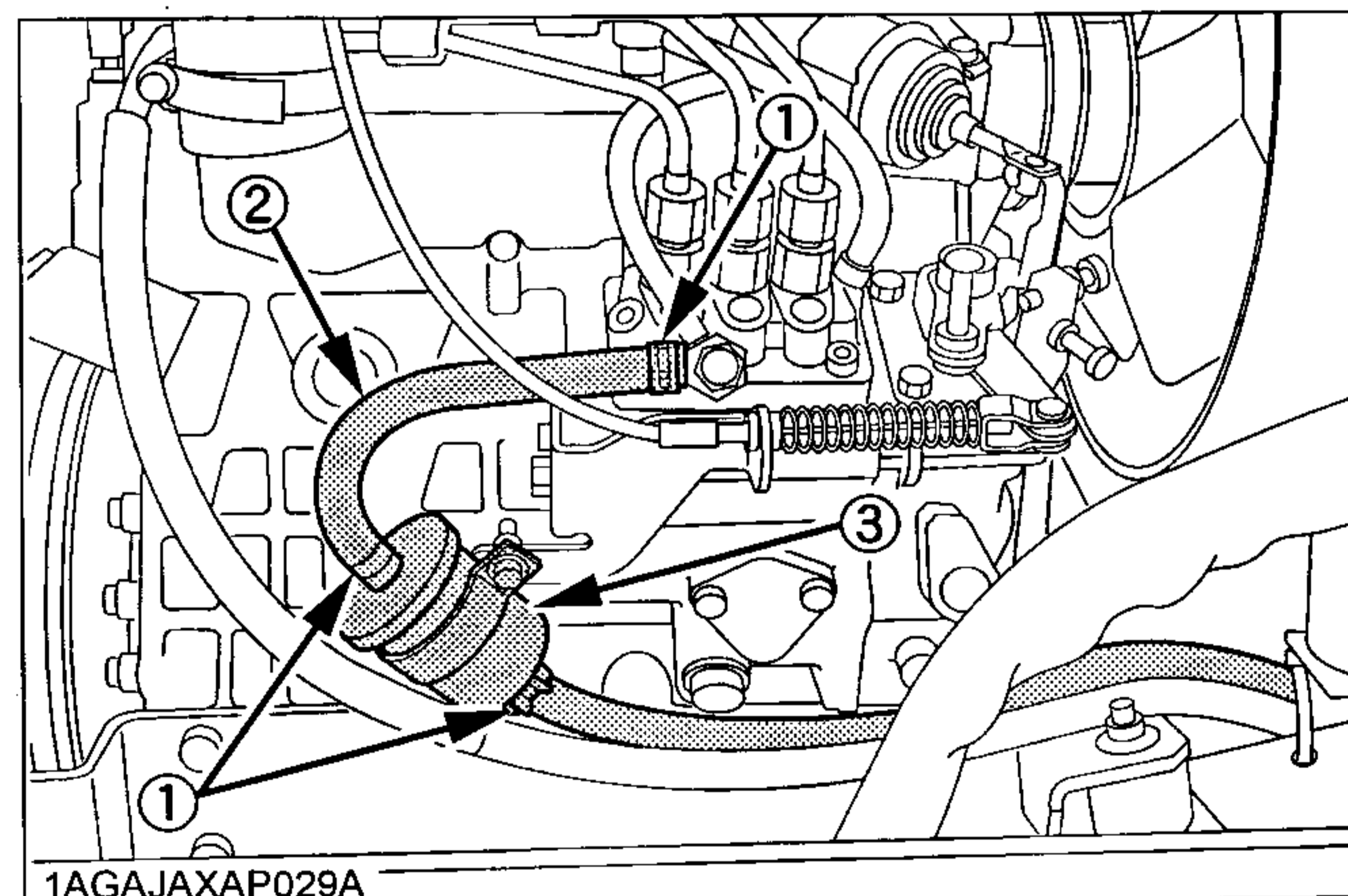

- 1AGA JAXAP029A
- (1) Pipe clamps
 - (2) Fuel line
 - (3) Fuel filter

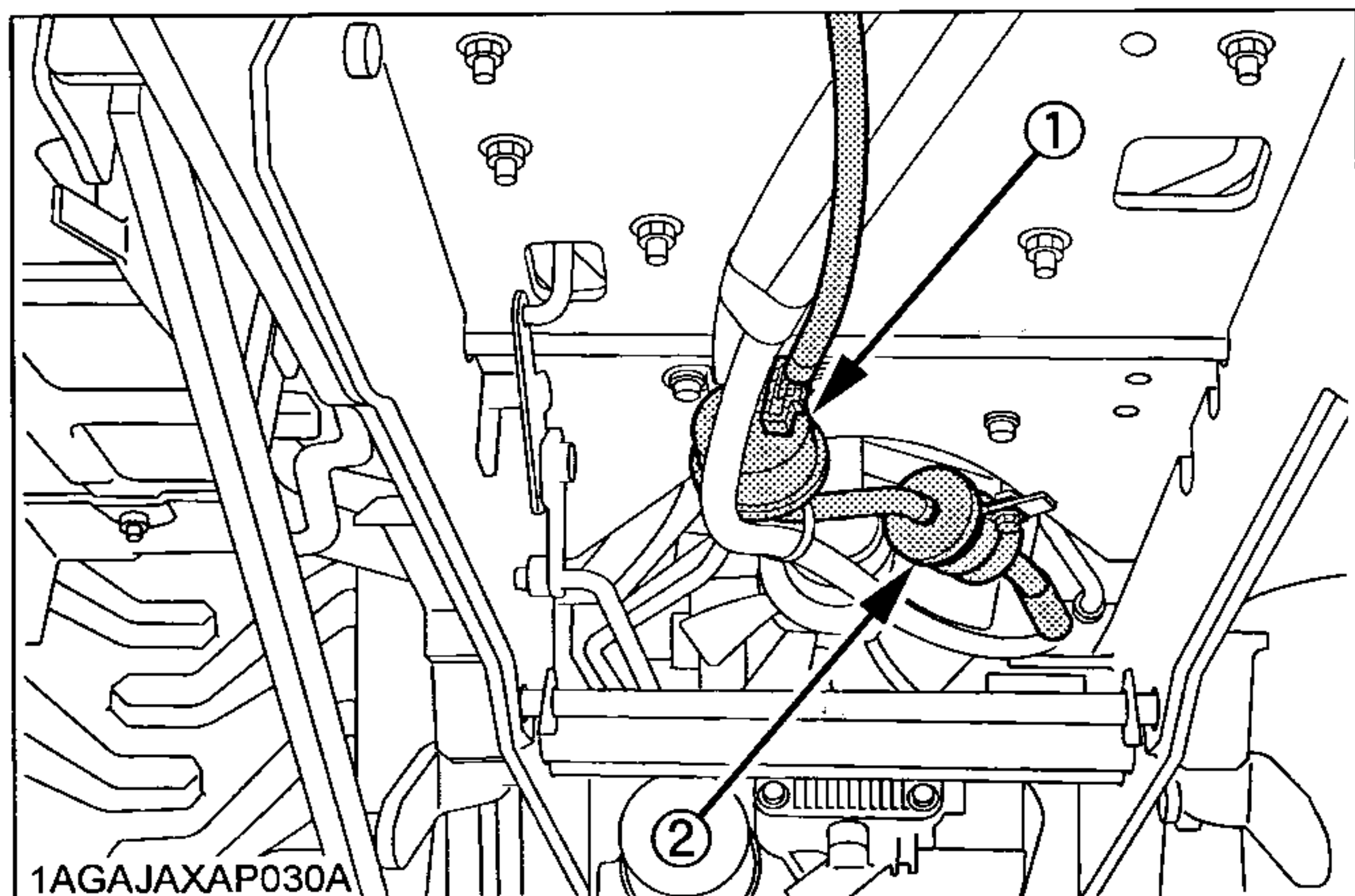

- (1) Fuel pump
- (2) Fuel filter

NOTE :

- If the fuel line is removed, be sure to properly bleed the fuel system.
(See "Bleeding Fuel System" in service as required)

■ Adjusting Fan Belt Tension

! CAUTION

To avoid personal injury:

- Be sure to stop the engine and remove the key before checking belt tension.

Proper fan belt tension	A deflection of between 7 to 9 mm (0.28 to 0.35 in.) when the belt is pressed in the middle of the span.
-------------------------	--

1. Stop the engine and remove the key.
2. Apply moderate thumb pressure to belt between pulleys.
3. If tension is incorrect, loosen the alternator mounting bolts and, using a lever placed between the alternator and the engine block, pull the alternator out until the deflection of the belt falls within acceptable limits.
4. Replace fan belt if it is damaged.

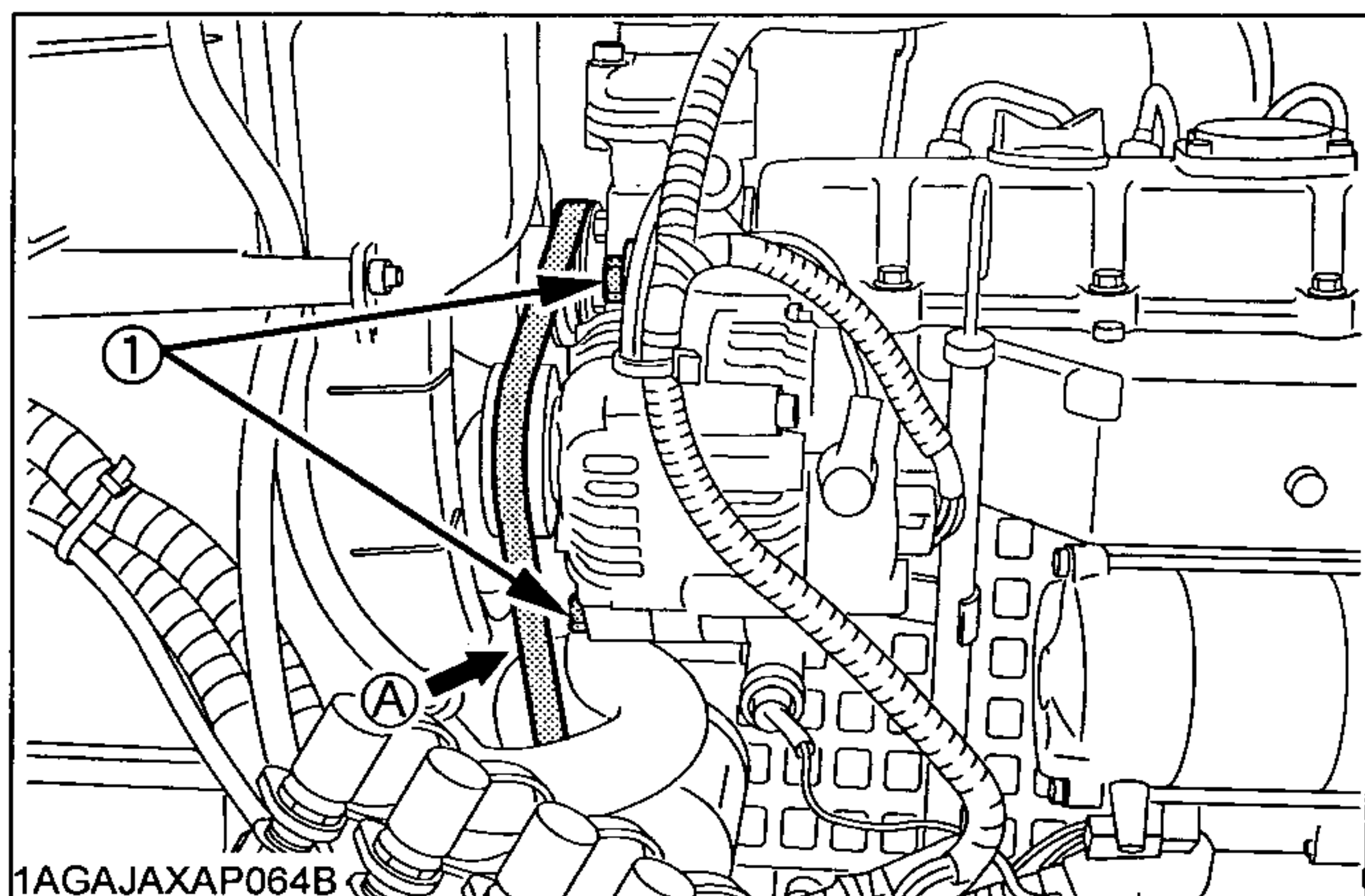

- (1) Bolt
- (A) Check the belt tension

■ Adjusting HST Neutral Spring (for Speed Control Pedal)

! WARNING

To avoid personal injury:

- Do not operate if tractor moves on level ground with foot off speed control pedal.
- If tractor moves on level ground with foot off the pedal, or, if the pedal is too slow in returning to "NEUTRAL" position when removing the foot from the pedal, consult your local KUBOTA Dealer.

The HST neutral spring located under the front right side of the fender can adjust returning speed of speed control pedal.

Consult your local KUBOTA Dealer for service.

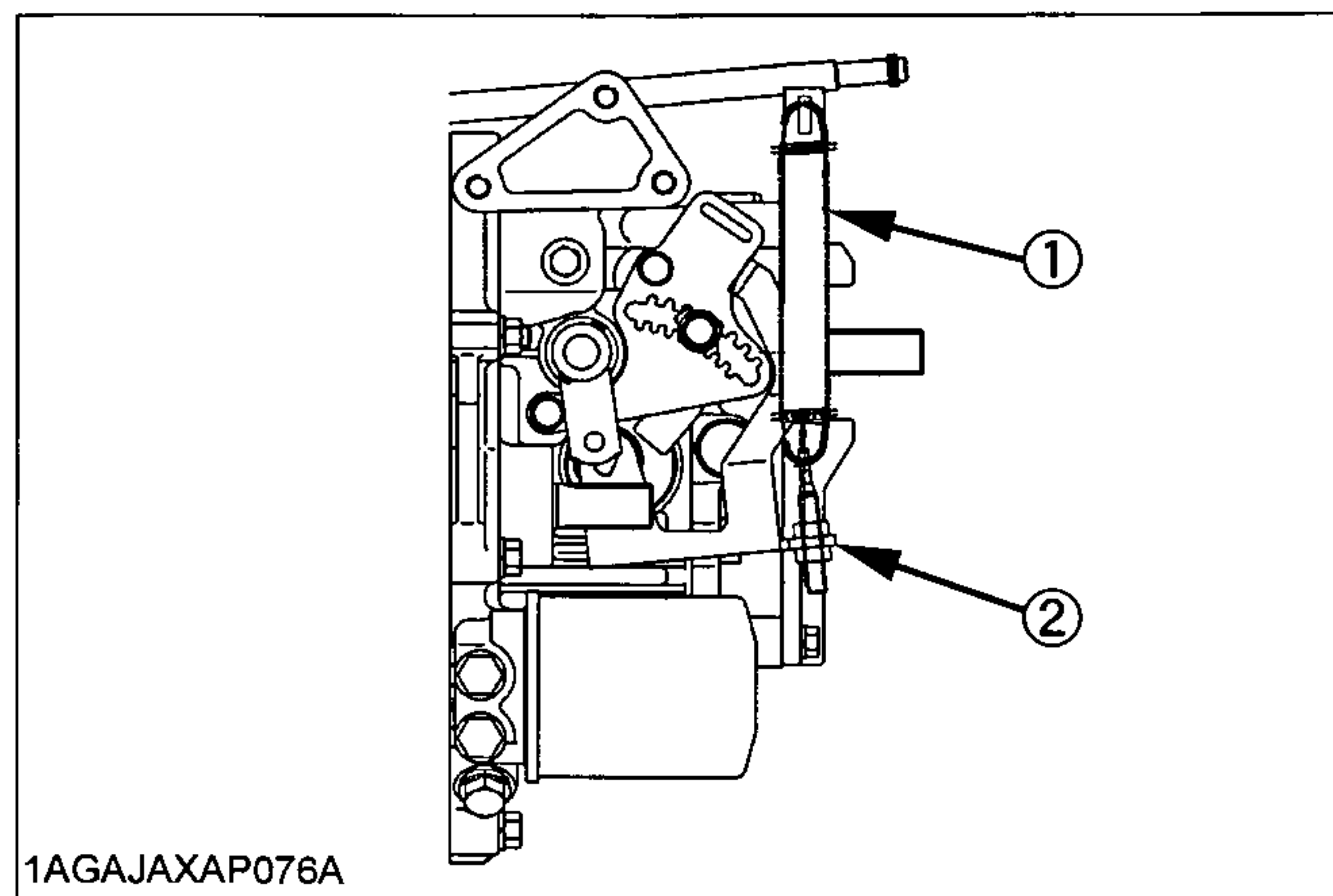

- (1) HST neutral spring
- (2) Adjusting nut

■ Adjusting Brake Pedal



CAUTION

To avoid personal injury:

- Stop the engine, remove the key, lower the implement to the ground, and chock the wheels before checking brake pedal.
- Even if the brake pedal free travel is within the limitation, adjust the brake pedal following the procedure below.
- If you are not able to adjust, consult your local KUBOTA Dealer.

Proper brake pedal free travel	25 to 35 mm (1.0 to 1.4 in.) on the pedal
--------------------------------	---

1. Release the parking brake.
2. Loosen the lock nut and turn the turnbuckle to adjust the rod length so that the brake pedal free travel is 10 mm (0.4 in.)
3. Extend the turnbuckle one additional turn.
4. Retighten the lock nut.
5. Depress the brake pedal several times and make sure the brake pedal free travel is from 25 to 35 mm (1.0 to 1.4 in.)

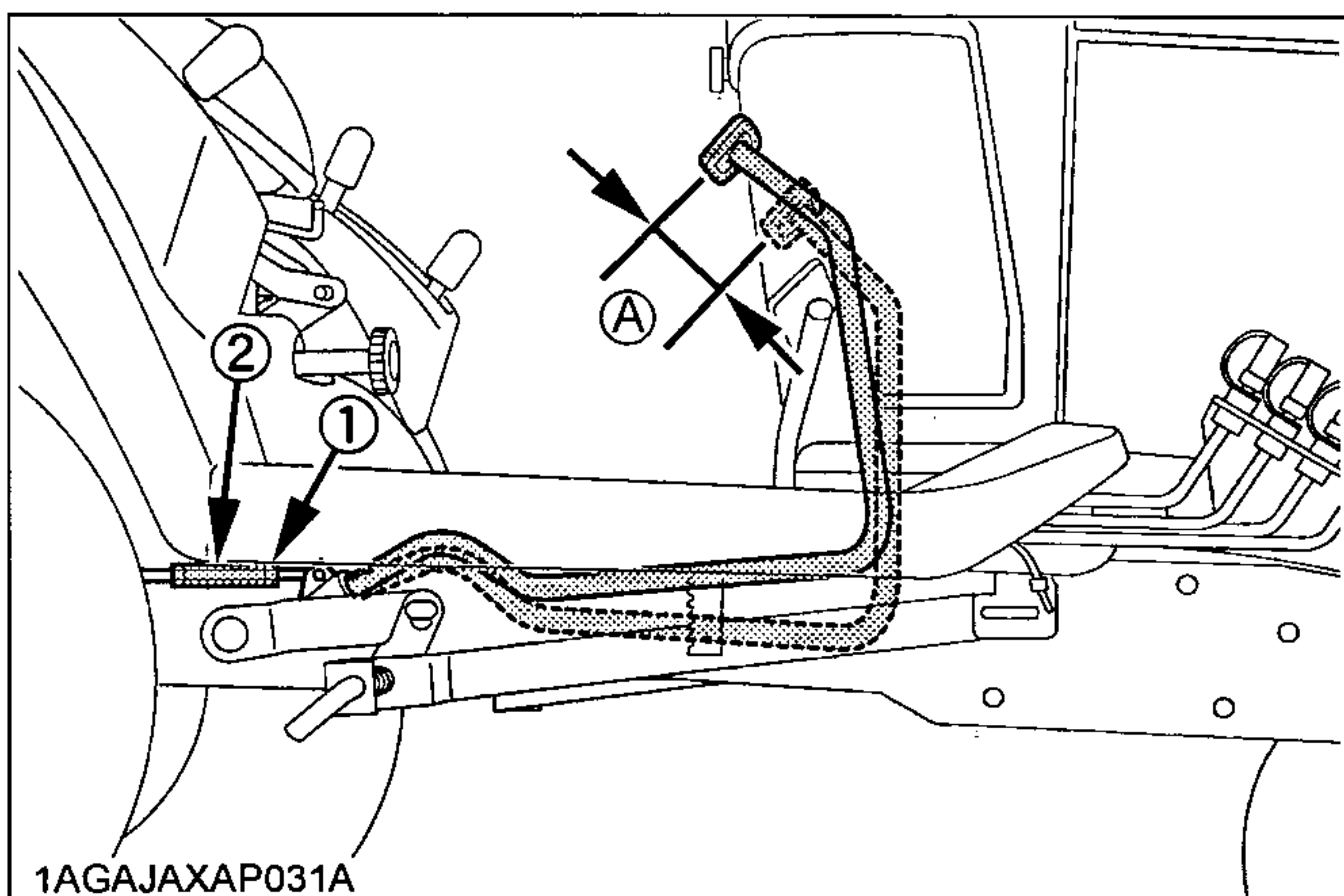

(1) Lock nut
(2) Turnbuckle

(A) Free travel

EVERY 200 HOURS

■ Replacing Engine Oil Filter



CAUTION

To avoid personal injury:

- Be sure to stop the engine before changing the oil filter cartridge.
 - Allow engine to cool down sufficiently, oil can be hot and can burn.
1. Remove the oil filter.
 2. Put a film of clean engine oil on the rubber seal of the new filter.
 3. Tighten the filter quickly until it contacts the mounting surface.
Tighten filter by hand an additional 1/2 turn only.
 4. After the new filter has been replaced, the engine oil normally decreases a little. Make sure that the engine oil does not leak through the seal and be sure to check the oil level on the dipstick. Then, replenish the engine oil up to the prescribed level.
 5. Properly dispose of used oil.

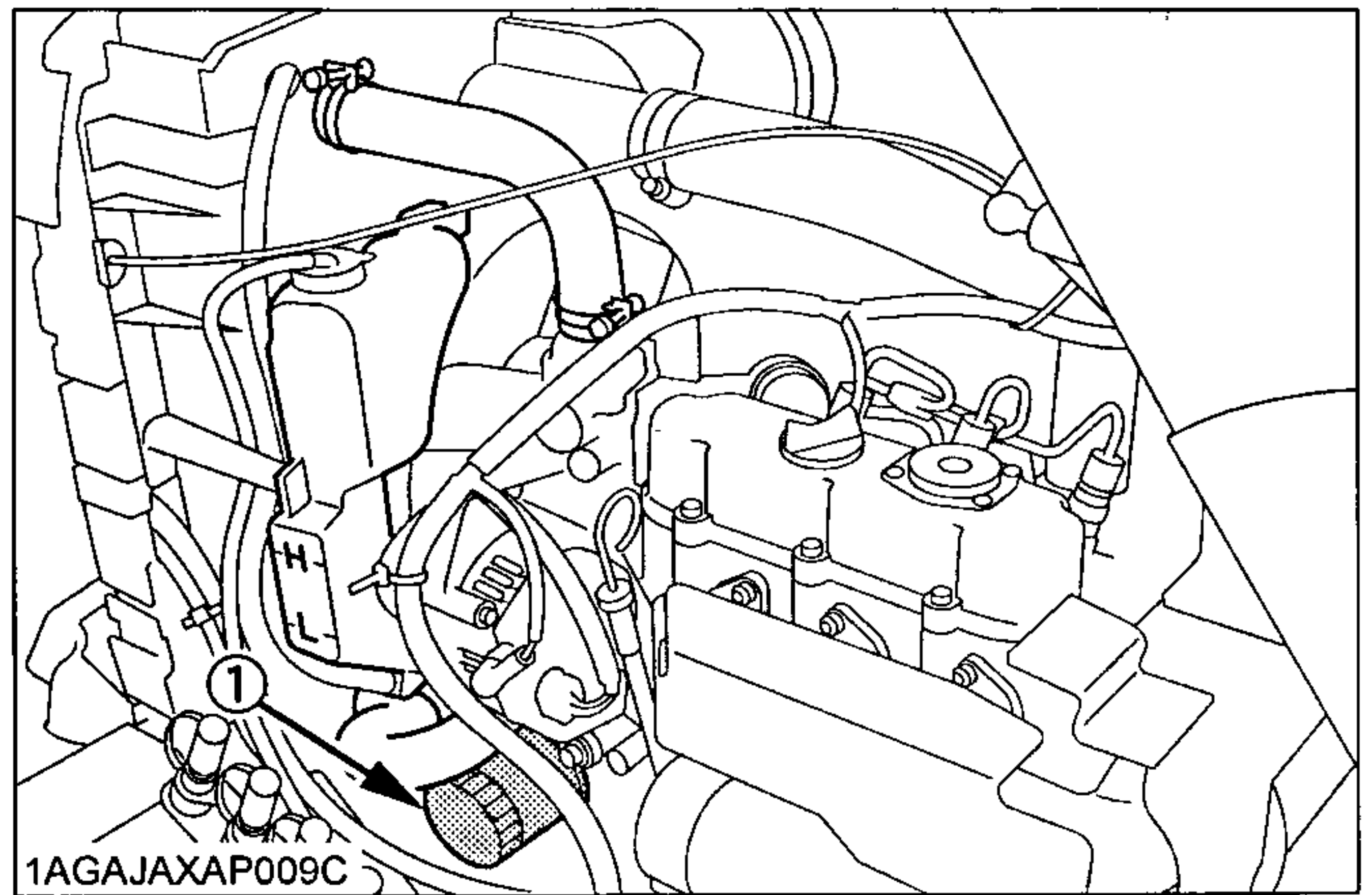

(1) Engine oil filter

IMPORTANT :

- To prevent serious damage to the engine, use only a KUBOTA genuine filter.

■ Checking Radiator Hoses and Clamps



CAUTION

To avoid personal injury:

- Be sure to stop the engine and remove the key before checking radiator hose and clamps.

Check to see if radiator hoses are properly secured every 200 hours of operation or six months, whichever comes first.

1. If hose clamps are loose or water leaks, tighten clamps securely.
2. Replace hoses and tighten hose clamps securely, if radiator hoses are swollen, hardened or cracked.
3. Properly dispose of used coolant.

Replace hoses and hose clamps every 2 years or earlier if checked and found that hoses are swollen, hardened or cracked.

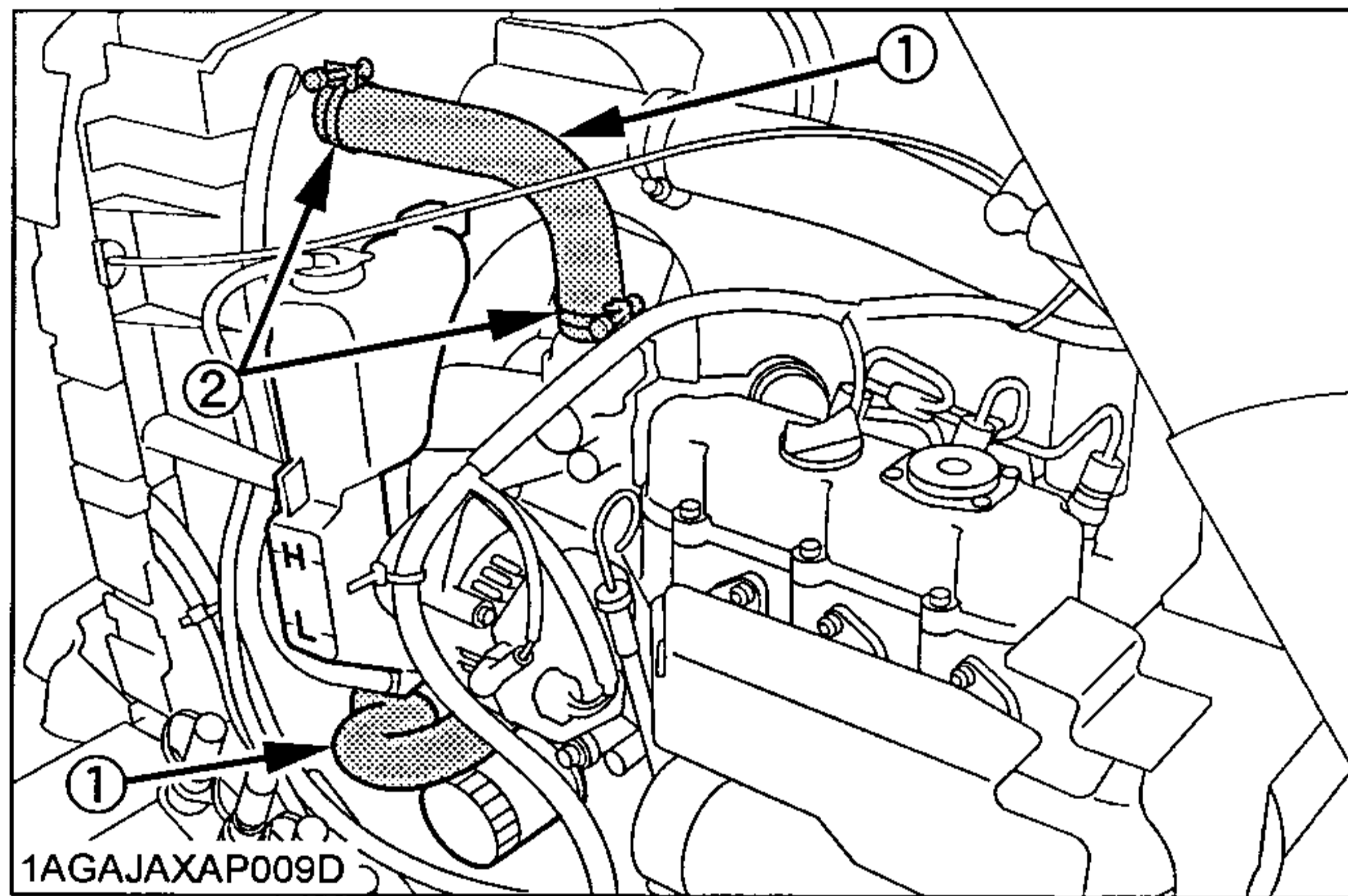

- (1) Radiator hoses (2 pcs)
(2) Hose clamps (4 pcs)

◆ Precaution at Overheating

Take the following actions in the event the coolant temperature be nearly or more than the boiling point, what is called "Overheating"

1. Stop the machine operation in a safe place and keep the engine unloaded idling.
2. Don't stop the engine suddenly, but stop it after about 5 minutes of unloaded idling.
3. Keep yourself well away from the machine for further 10 minutes or while the steam blown out.
4. Checking that there is no danger such as burn, get rid of the causes of overheating according to the manual, see "Troubleshooting" section, and then, start again the engine.

■ Checking Intake Air Line

1. Check to see that hose and hose clamps are tight and not damaged.
2. If hose and clamps are found worn or damaged, replace or repair them at once.

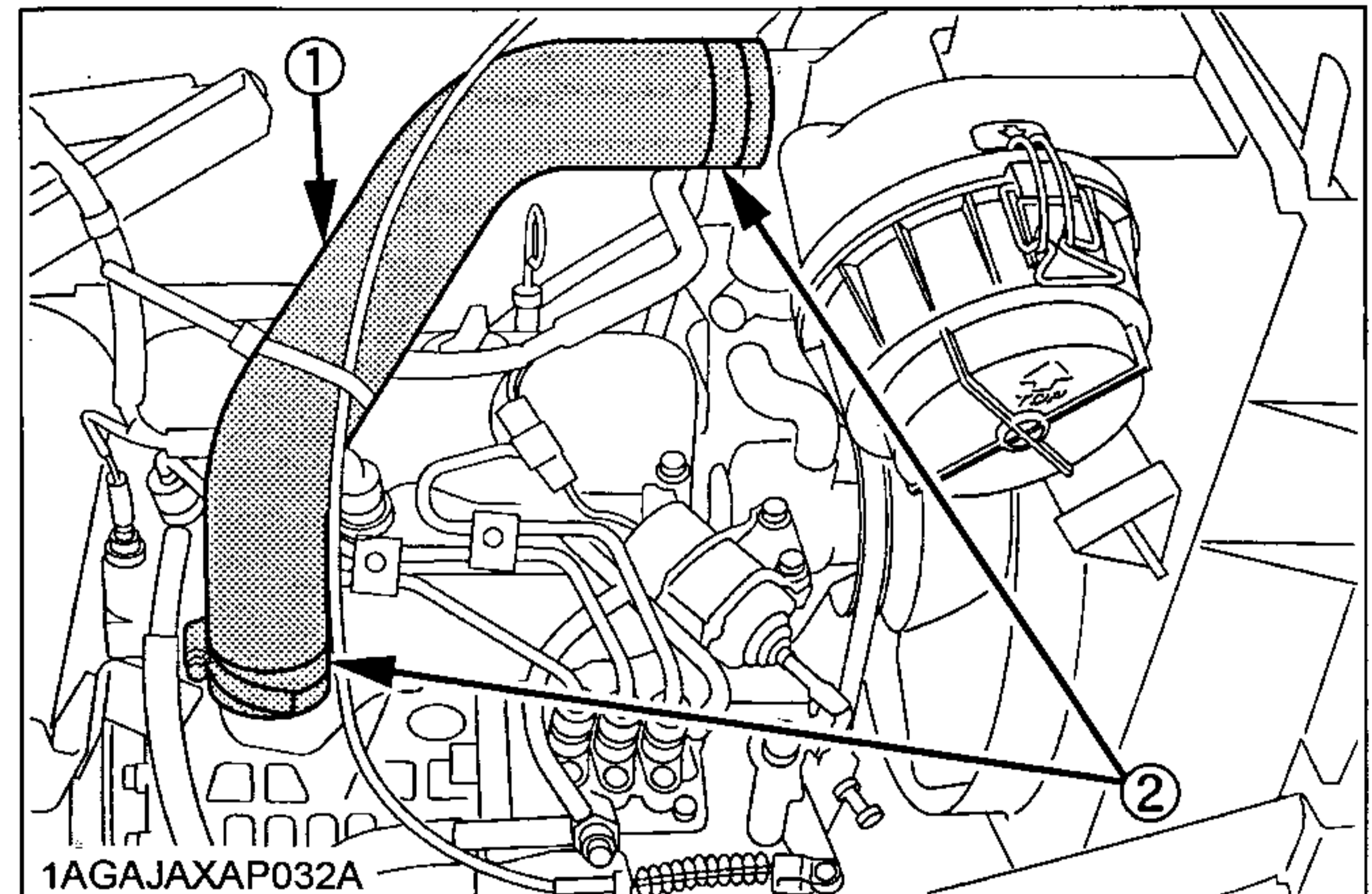

- (1) Hose
(2) Hose clamps

■ Adjusting Toe-in

1. Park tractor on a firm, flat and level place.
2. Turn steering wheel so front wheels are in the straight ahead position.
3. Lower the implement to the ground, lock the parking brake, stop the engine and remove the key.
4. Measure distance between tire beads at front of tire, hub height.
5. Measure distance between tire beads at rear of tire, hub height.
6. Front distance should be 0 to 5 mm (0 to 0.2 in.) less than rear distance. If not, adjust tie rod length.

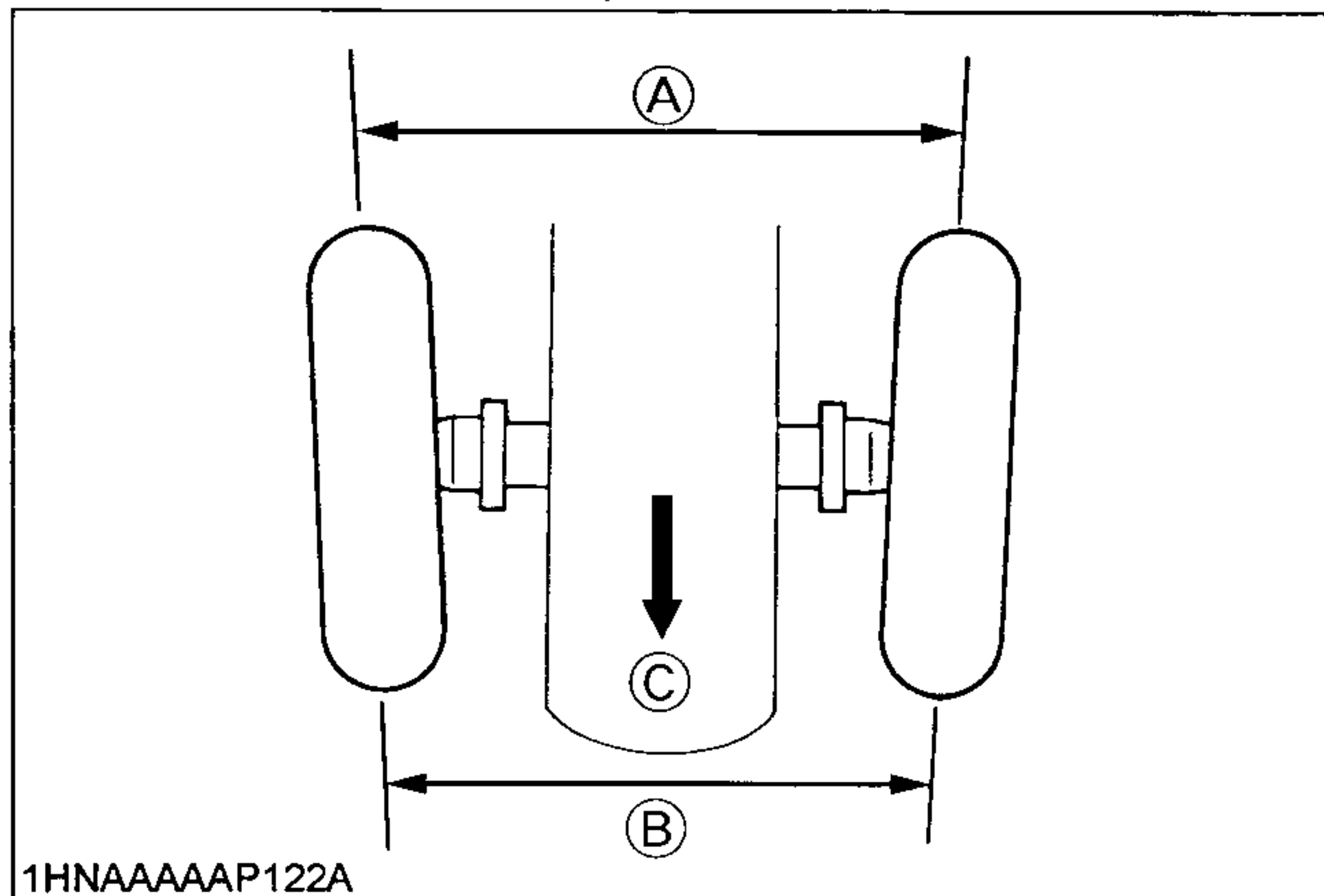

(A) Wheel - to - wheel distance at rear
 (B) Wheel - to - wheel distance at front
 (C) "FRONT"

◆ Adjusting procedure

1. Loosen the lock nut and turn the tie rod to adjust the rod length until the proper toe-in measurement is obtained.
2. Retighten the lock nut.

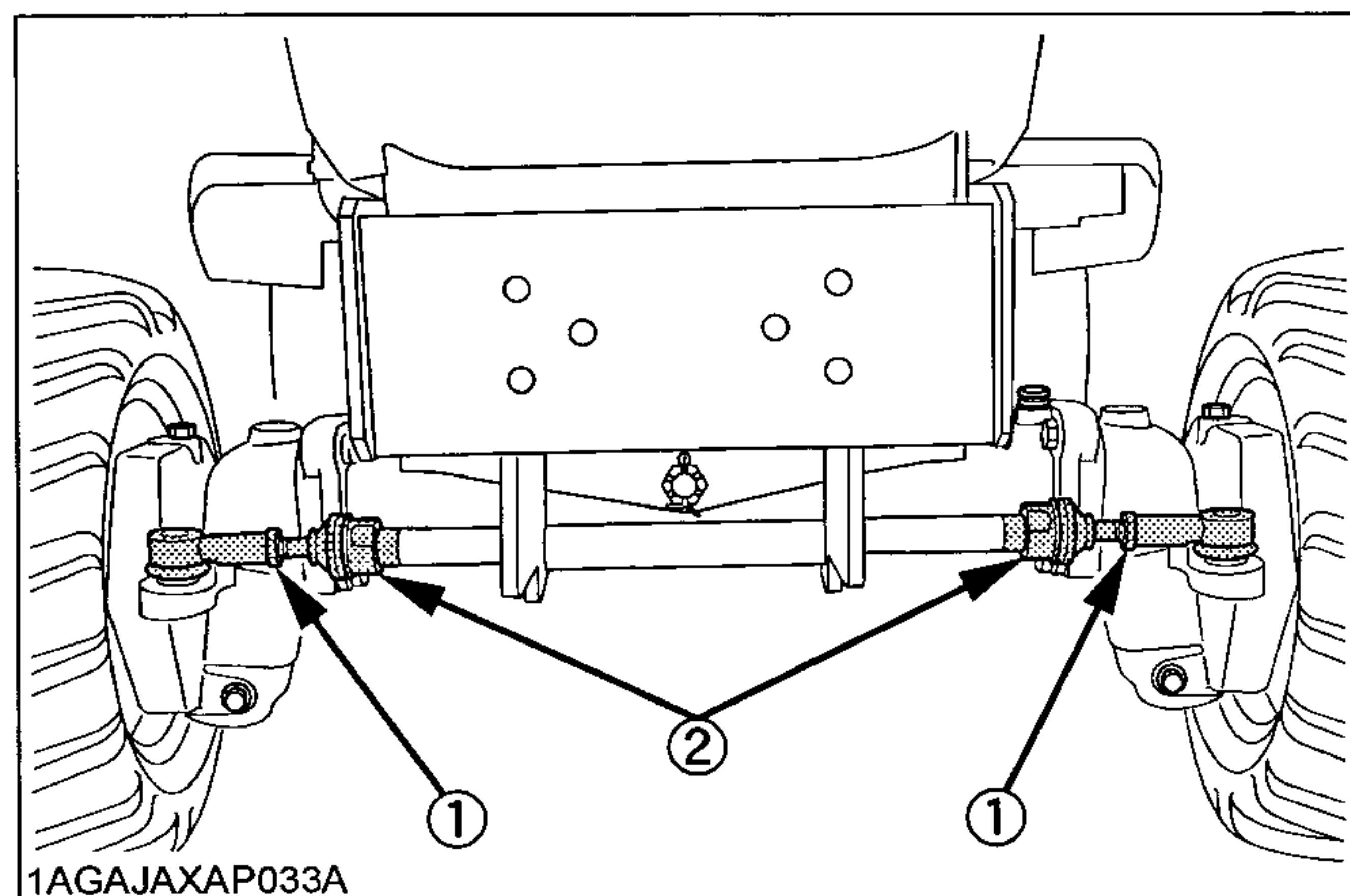

(1) Lock nuts
 (2) Tie-rod

■ Checking Power Steering Line



CAUTION

To avoid personal injury:

- Be sure to stop the engine and remove the key before checking power steering line.

1. Check to see that all lines are tight and not damaged.
2. If hoses are found to be worn or damaged, replace or repair them at once.

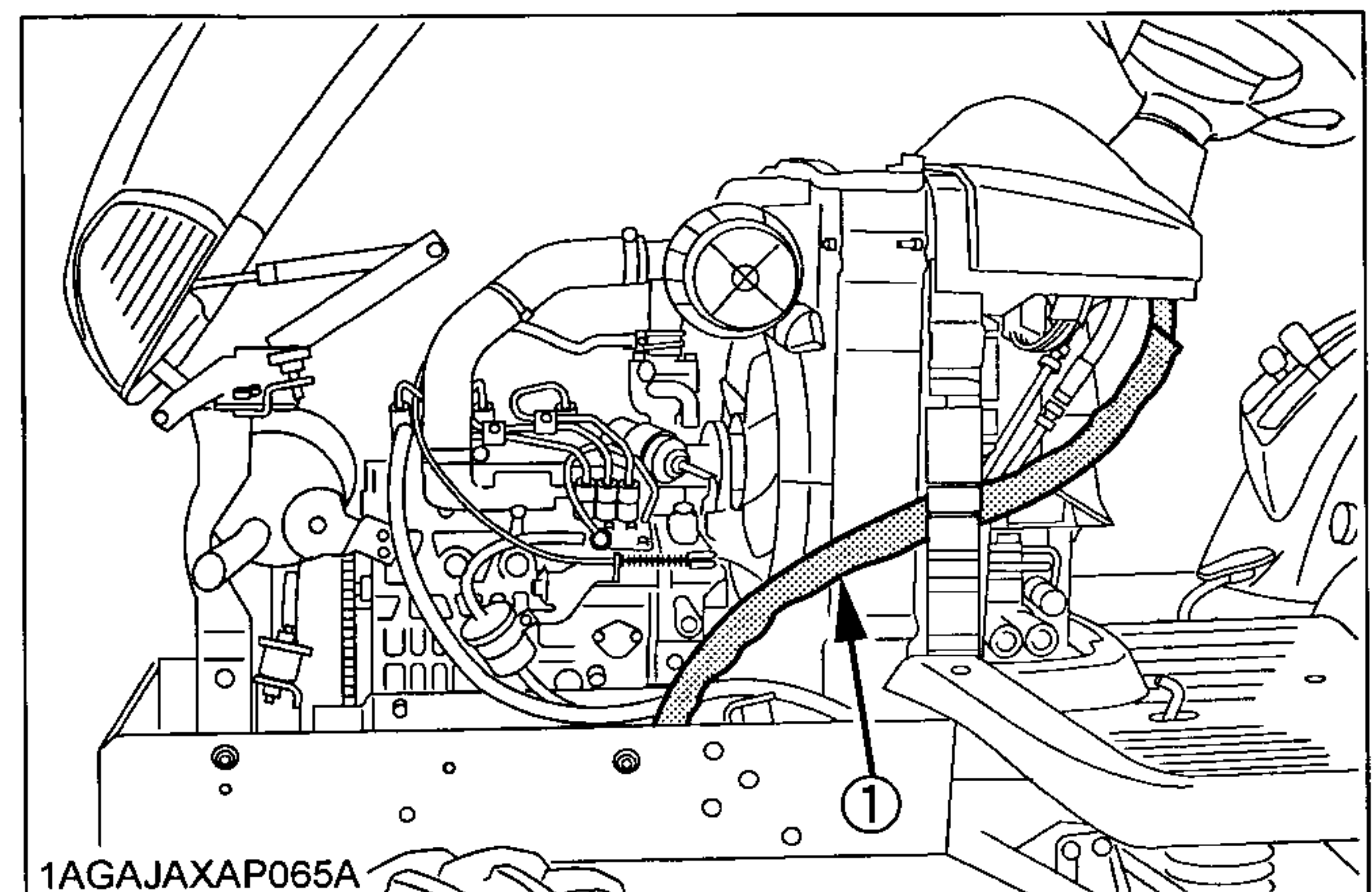
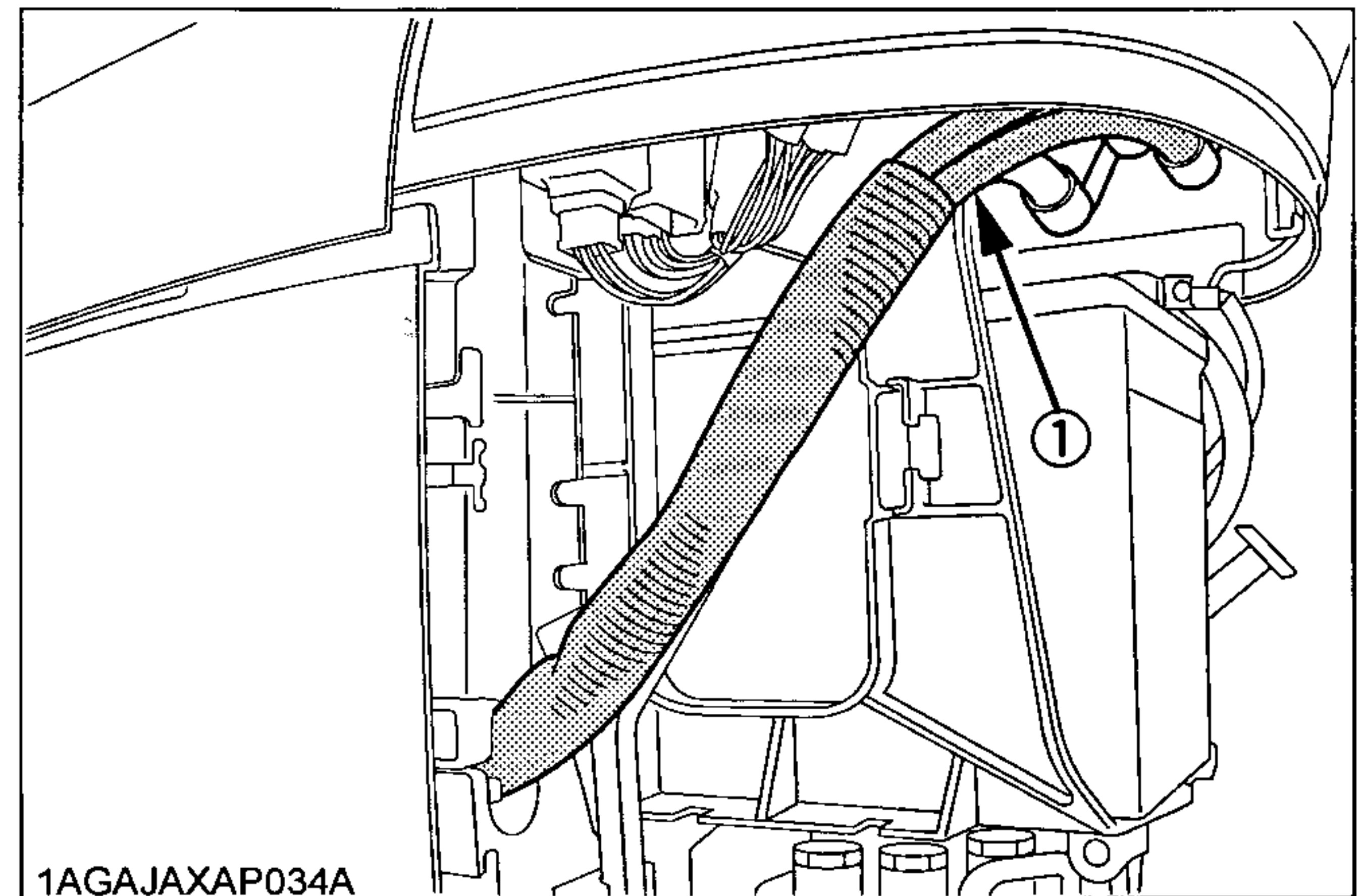

(1) Power steering pressure hoses

EVERY 300 HOURS

■ Changing Transmission Fluid

CAUTION

To avoid personal injury:

- Allow engine to cool down sufficiently, oil can be hot and can burn.

1. To drain the used oil, remove the drain plug at the bottom of the transmission case and drain the oil completely into the oil pan.
2. After draining reinstall the drain plug. Clean the transmission strainer. Fill with new KUBOTA SUPER UDT fluid up to the upper notch on the dipstick. (See "LUBRICANTS" and "DAILY CHECK" in Maintenance Section) After running the engine for a few minutes, stop it and check the oil level again, add oil to prescribed level. Properly dispose of used oil.

Oil capacity	11.6 L (3.1 U.S.gals.)
--------------	------------------------

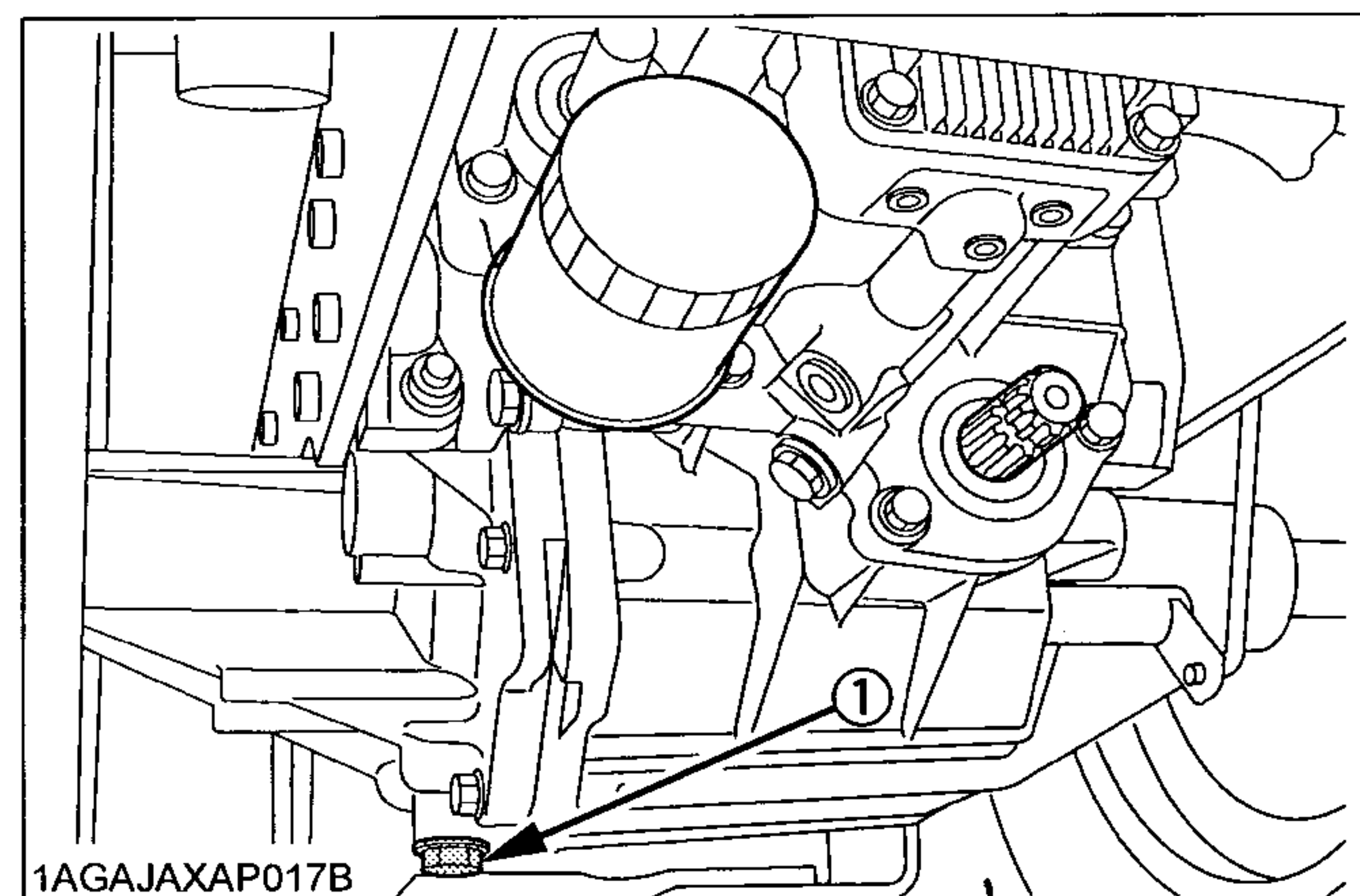

(1) Drain plug

27 mm OR 1 1/8"

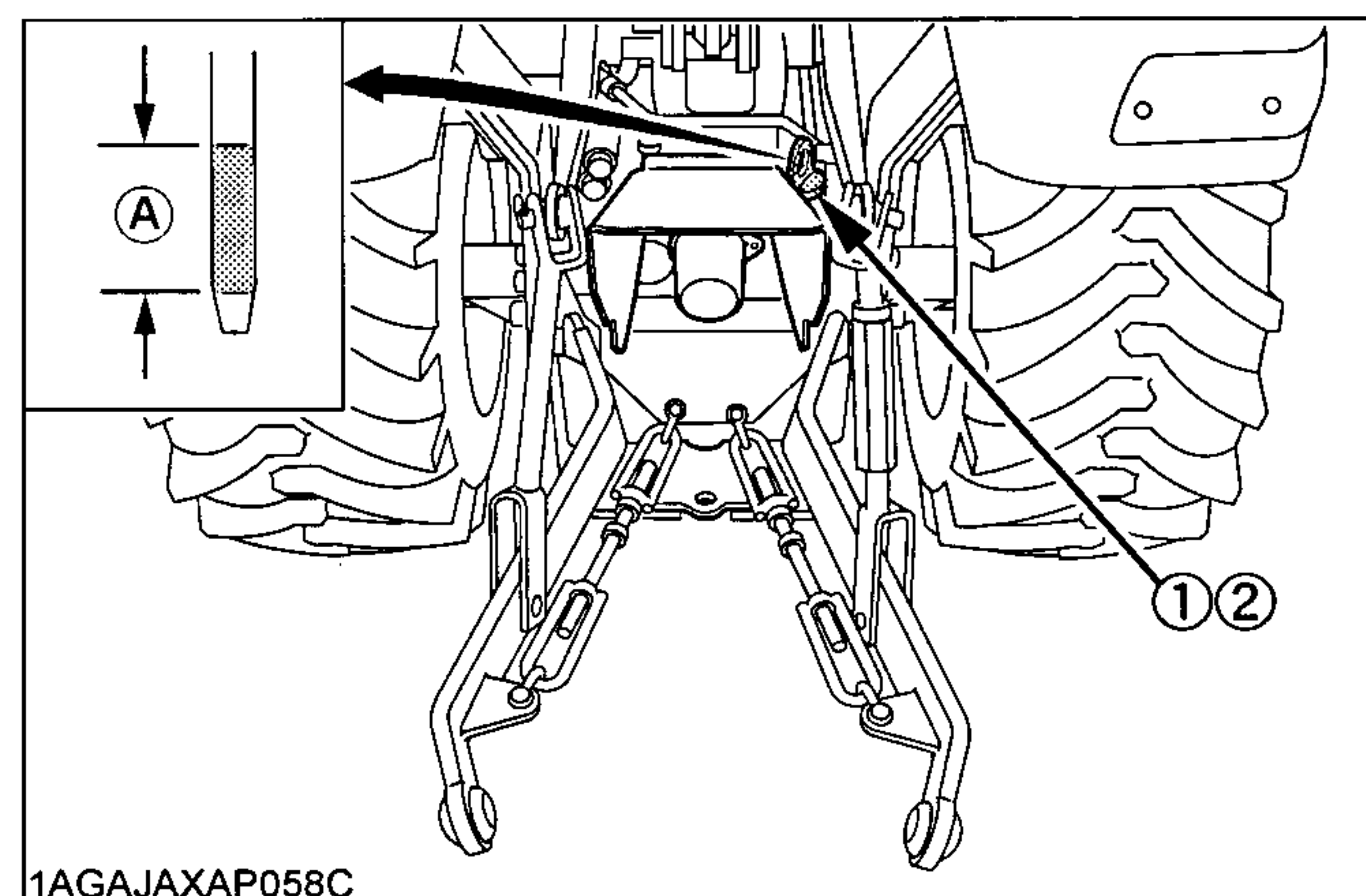

(1) Oil inlet
(2) Dipstick

(A) Oil level is acceptable within this range.

IMPORTANT :

- Do not operate the tractor immediately after changing the transmission fluid.
Run the engine at medium speed for a few minutes to prevent damage to the transmission.

■ Cleaning Transmission Strainer

When changing the transmission fluid, disassemble and rinse the strainer with nonflammable solvent to completely clean off filings.

When reassembling be careful not to damage the parts.

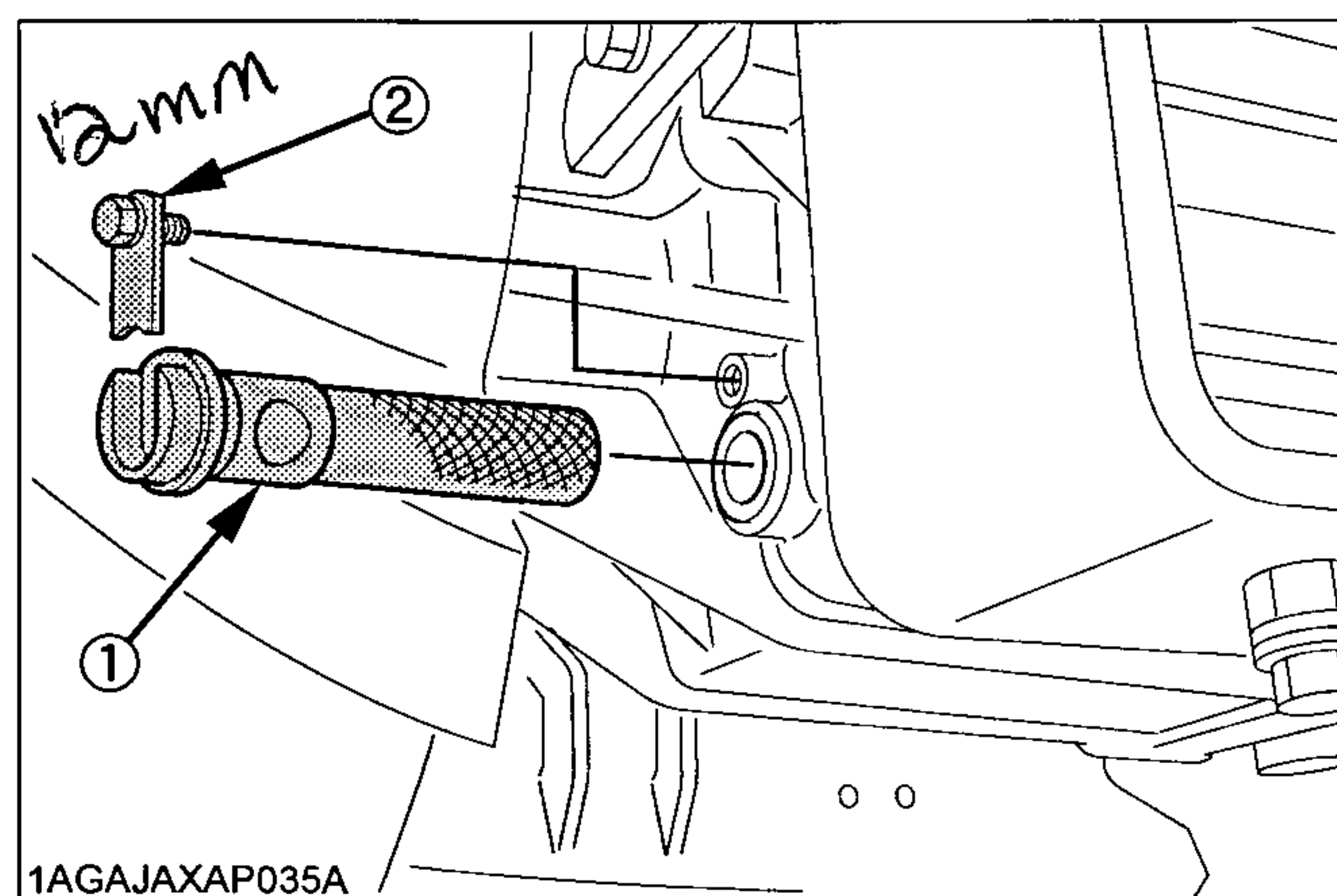
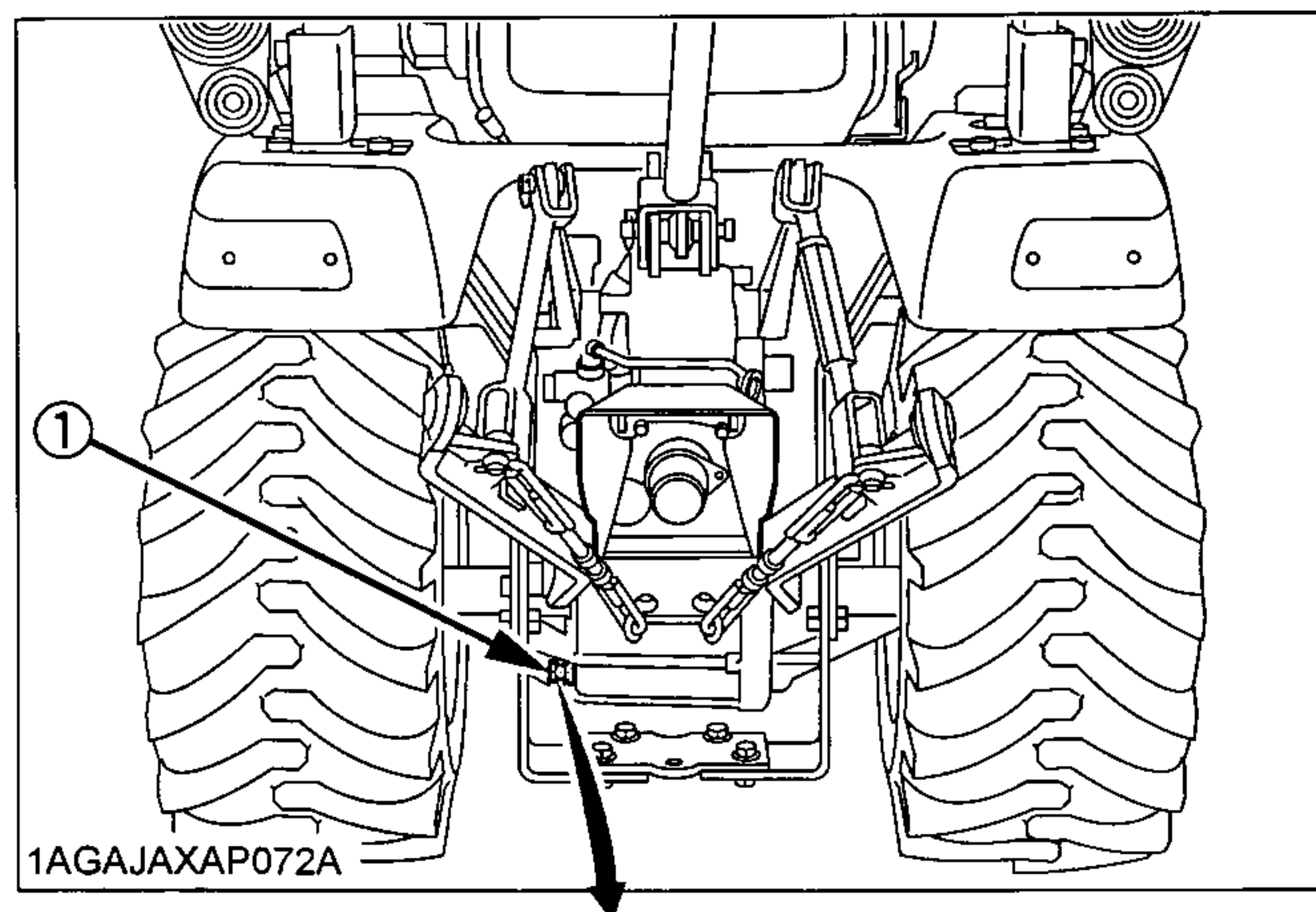

(1) Strainer
(2) Filter plate

NOTE :

- Since the fine filings in the oil can damage the precision component parts of the hydraulic system, the end of the suction line is provided with an oil strainer.

■ Replacing Transmission Oil Filter



CAUTION

To avoid personal injury:

- Allow engine to cool down sufficiently, oil can be hot and can burn.

1. Remove the oil filter.
2. Put a film of clean transmission oil on rubber seal of new filter.
3. Tighten the filter quickly until it contacts the mounting surface.
Tighten filter by hand an additional 1/2 turn only.
4. After the new filter has been replaced, the transmission fluid level will decrease a little. Make sure that the transmission fluid does not leak through the seal, and check the fluid level.
Top off if necessary.
5. Properly dispose of used oil.

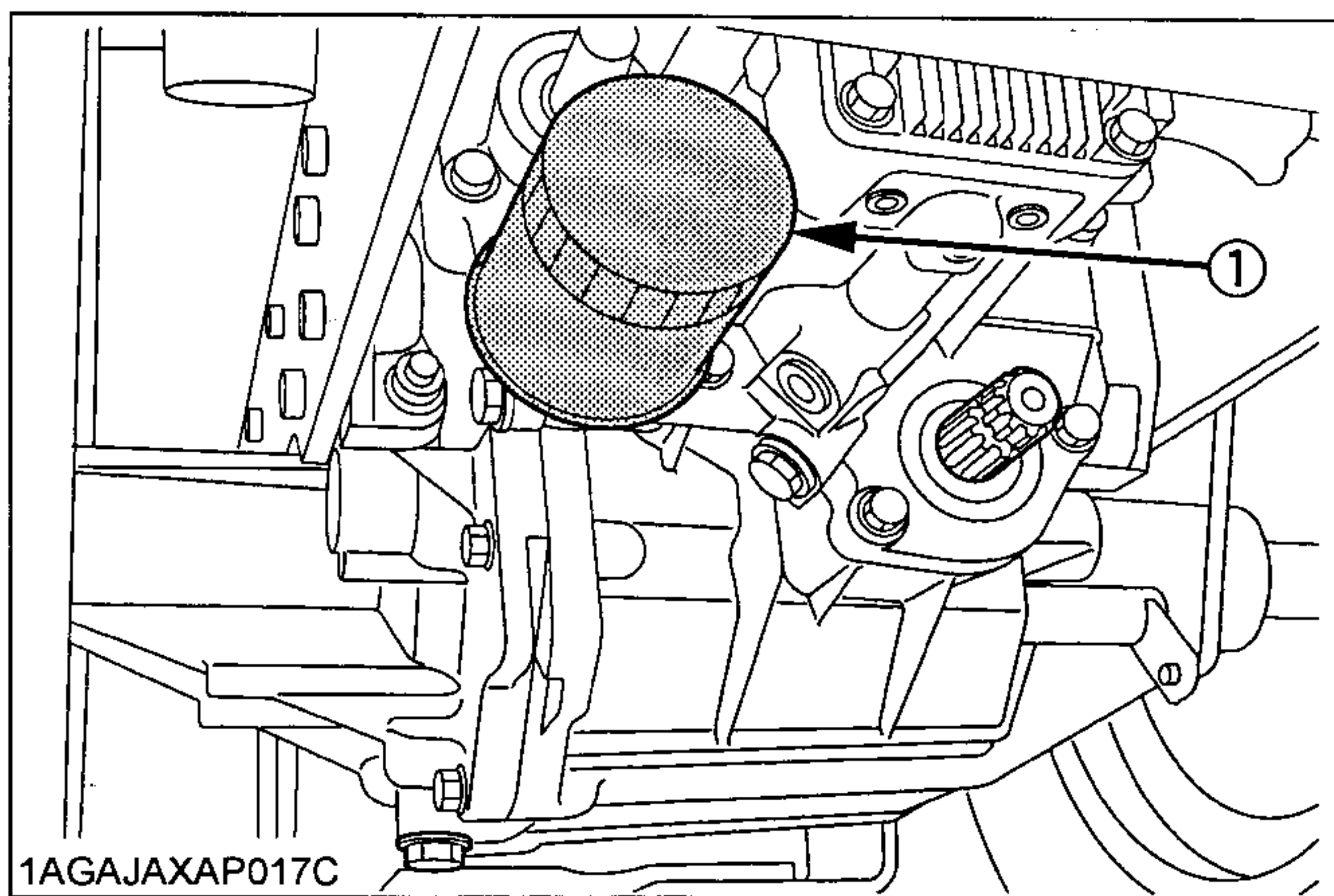

(1) Filter

IMPORTANT :

- To prevent serious damage to the hydraulic system, use only a KUBOTA genuine filter.

■ Changing Front Axle Case Oil

1. Park the machine on a firm, flat and level surface.
2. To drain the used oil, remove the right and left drain plugs and oil gauge at the front axle case and drain the oil completely into the oil pan.
3. After draining, reinstall the drain plugs.
4. Remove the right and left breather plugs.
5. Fill with new oil up to the upper notch on the dipstick.
(See "LUBRICANTS" in Maintenance Section)

IMPORTANT :

- After ten minutes, check the oil level again; add oil to prescribed level.
6. After filling, reinstall the oil gauge and breather plugs.

Oil capacity	BX1850	2.3 L (2.4 U.S.qts.)
	BX2350	4.7 L (5.0 U.S.qts.)

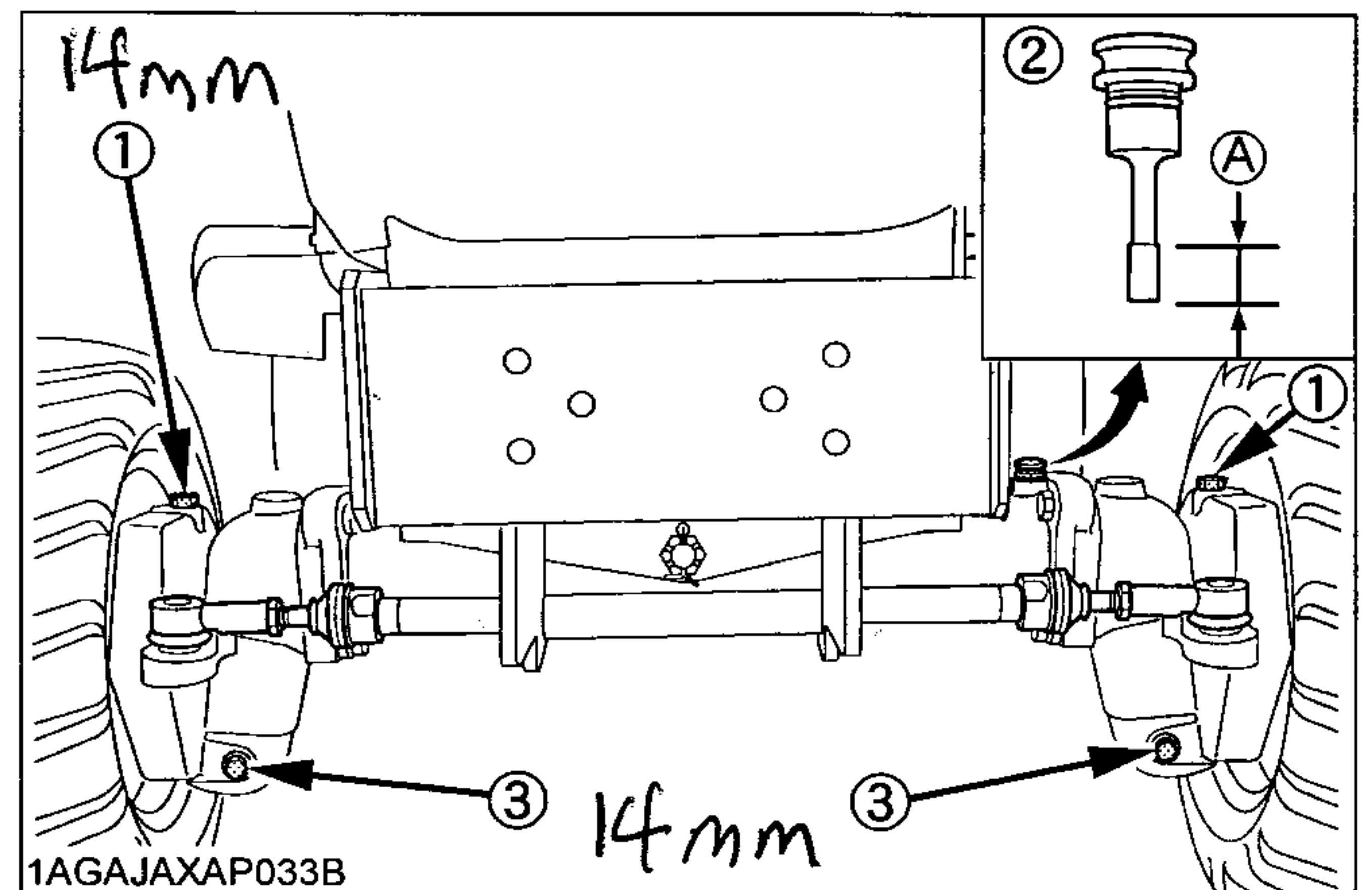

- (1) Breather plug
- (2) Oil gauge with dipstick
- (3) Drain plug

(A) Oil level is acceptable within this range

EVERY 400 HOURS

■ Adjusting Front Axle Pivot

If the front axle pivot pin adjustment is not correct, front wheel vibration can occur causing vibration in the steering wheel.

◆ Adjusting procedure

Remove the split pin, tighten the adjusting nut (tightening torque 20 N-m, 2.0 kgf-m, 15 lbs.-ft), then make sure that one of the nut slots aligns with the split pin hole, tighten the nut slightly if necessary to align. Replace the split pin.

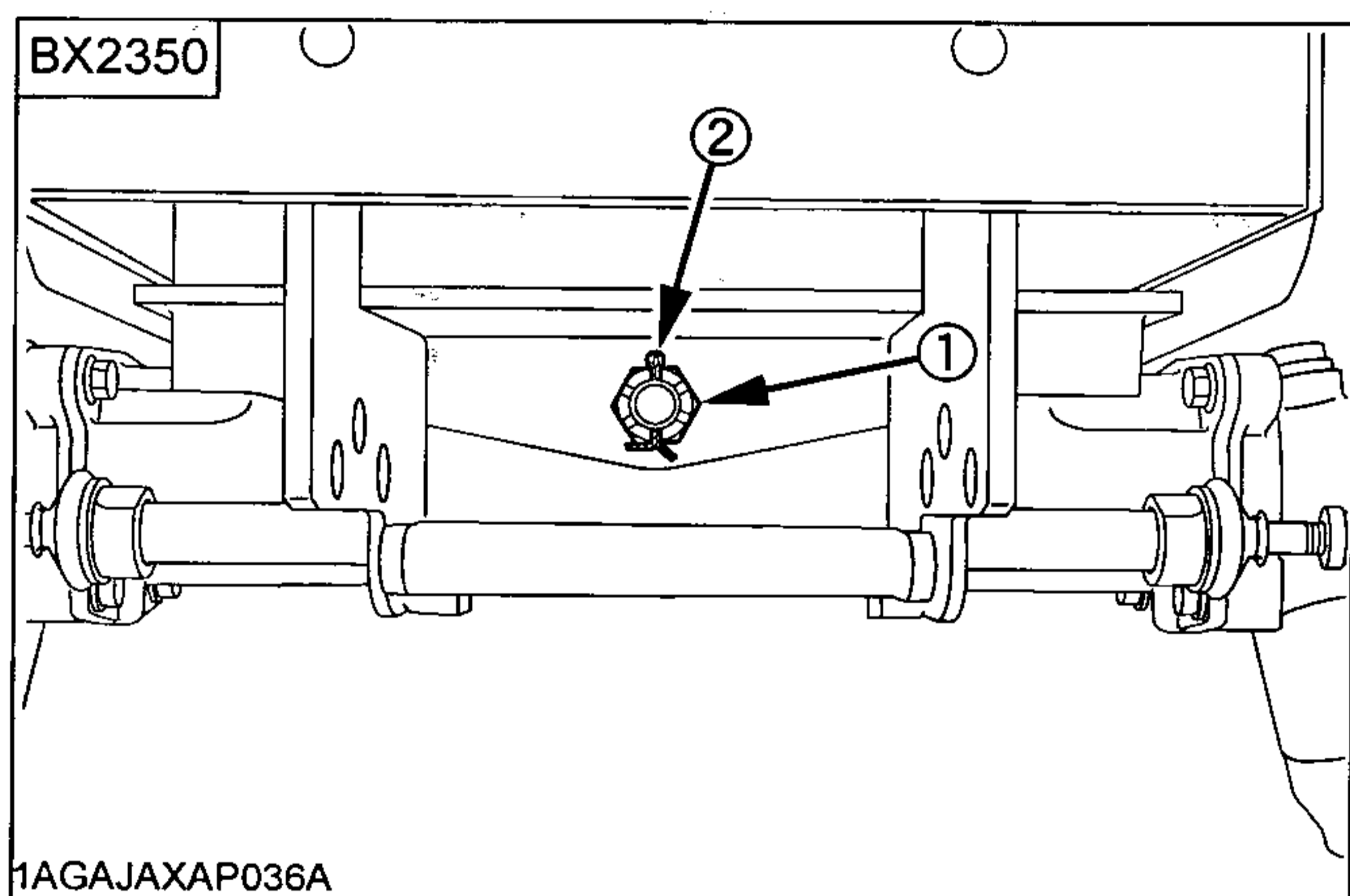
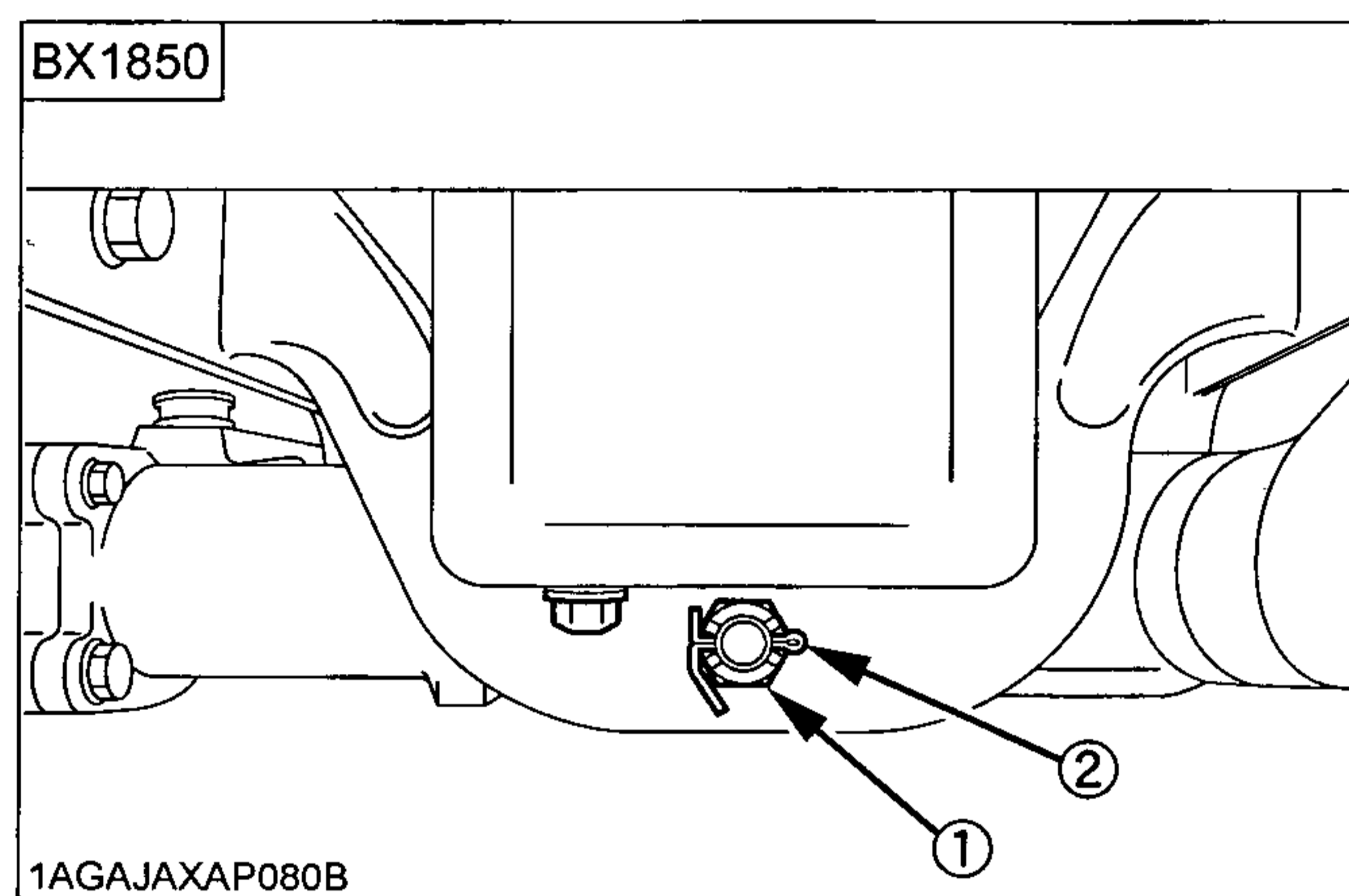

(1) Adjusting nut
(2) Split pin

EVERY 500 HOURS

■ Replacing Fuel Filter Element

Consult your local KUBOTA Dealer for this service.

EVERY 800 HOURS

■ Adjusting Engine Valve Clearance

Consult your local KUBOTA Dealer for this service.

EVERY 1500 HOURS

■ Checking Fuel Injection Nozzle Injection Pressure

Consult your local KUBOTA Dealer for this service.

EVERY 3000 HOURS

■ Checking Injection Pump

Consult your local KUBOTA Dealer for this service.

EVERY 1 YEAR

■ Replacing Air Cleaner Element

(See "Cleaning Air Cleaner Element" in every 100 hours maintenance)

EVERY 2 YEARS

■ Flush Cooling System and Changing Coolant



CAUTION

To avoid personal injury:

- Do not remove radiator cap while coolant is hot. When cool, slowly rotate cap to the first stop and allow sufficient time for excess pressure to escape before removing the cap completely.

1. Stop the engine and let cool down.
2. To drain the coolant, remove the radiator hose and the radiator cap. The radiator cap must be removed to completely drain the coolant.
3. After all coolant is drained, install the hose securely.
4. Fill with clean water and cooling system cleaner.
5. Follow directions of the cleaner instruction.
6. After flushing, fill with clean water and anti-freeze until the coolant level is just below the port.
7. Fill with clean water and anti-freeze up to the upper line of recovery tank.
8. Install the radiator cap securely.
9. Start and operate the engine for a few minutes.
10. Stop the engine. Check coolant level and add coolant if necessary.

Coolant capacity (with recovery tank)	BX1850	2.9 L (3.06 U.S.qts.)
	BX2350	3.1 L (3.3 U.S.qts.)

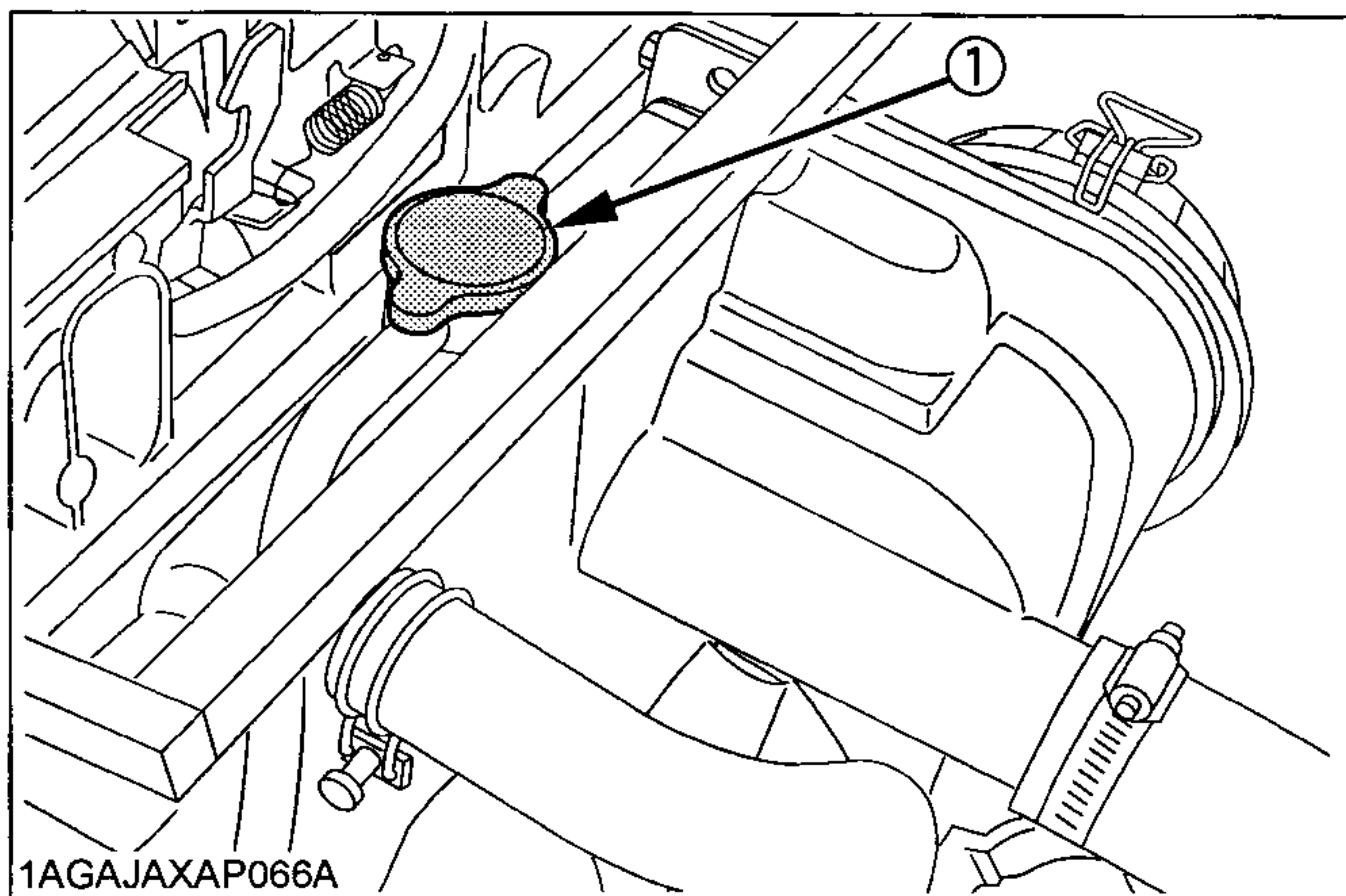

(1) Radiator cap

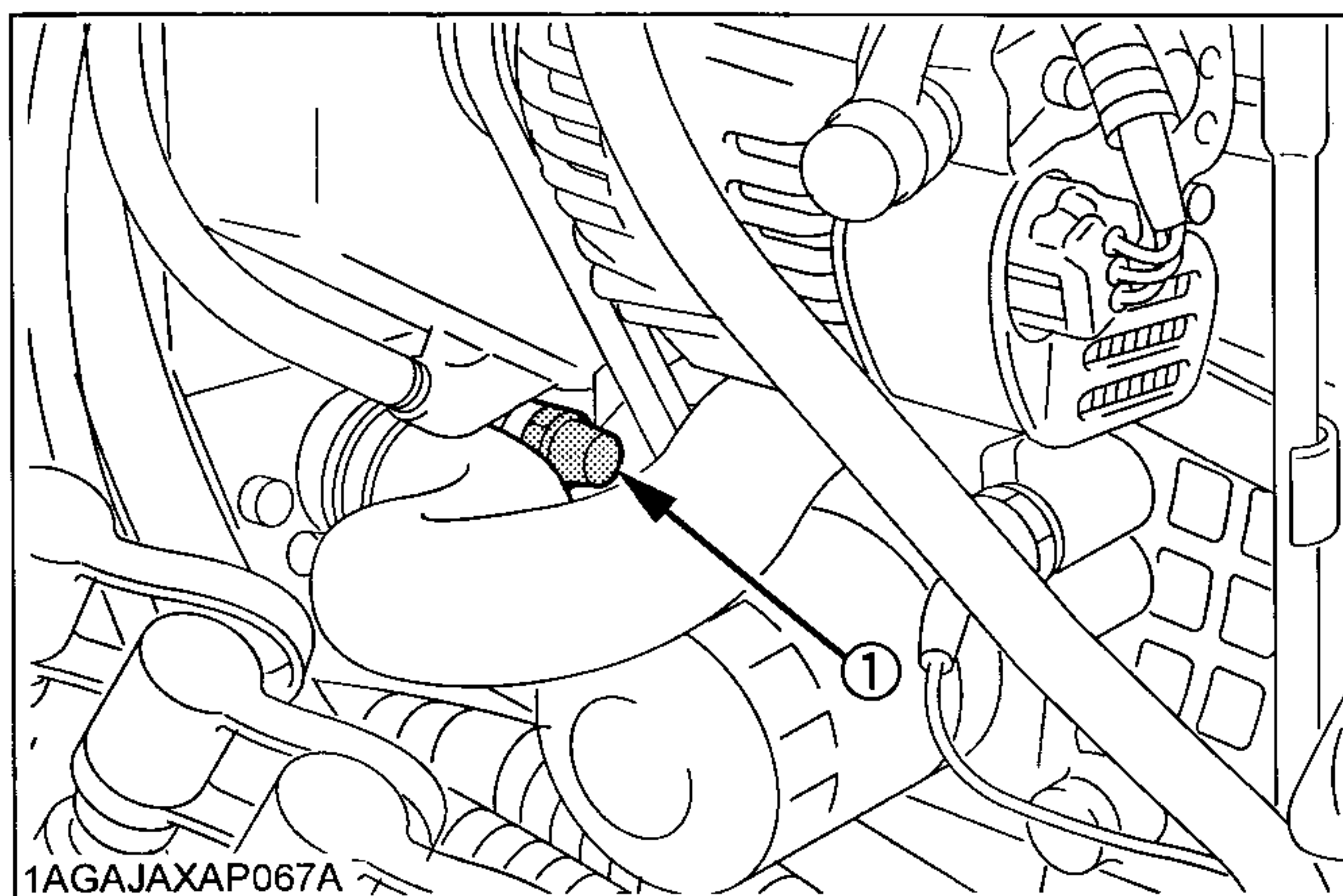

(1) Drain plug

IMPORTANT :

- Do not start engine without coolant.
- Use clean, fresh water and anti-freeze to fill the radiator.
- When the anti-freeze is mixed with water, the anti-freeze mixing ratio must be less than 50%.
- Securely tighten radiator cap. If the cap is loose or improperly fitted, water may leak out and the engine could overheat.

■ Anti-Freeze



CAUTION

To avoid personal injury:

- When using antifreeze, put on some protection such as rubber gloves (Antifreeze contains poison.).
- If should drink antifreeze, throw up at once and take medical attention.
- When antifreeze comes in contact with the skin or clothing, wash it off immediately.
- Do not mix different types of Antifreeze. The mixture can produce chemical reaction causing harmful substances.
- Antifreeze is extremely flammable and explosive under certain conditions. Keep fire and children away from antifreeze.
- When draining fluids from the engine, place some container underneath the engine body.
- Do not pour waste onto the grounds, down a drain, or into any water source.
- Also, observe the relevant environmental protection regulations when disposing of antifreeze.

If it freezes, coolant can damage the cylinders and radiator. If the ambient temperature falls below 0°C (32°F) or before a long-term storage, let out cooling water completely, or mix fresh water with long-life coolant and fill the radiator and reserve tank with the mixture.

1. Long-life coolant (hereafter LLC) comes in several types. Use ethylene glycol (EG) type for this engine.
2. Before employing LLC-mixed cooling water, fill the radiator with fresh water and empty it again. Repeat this procedure 2 or 3 times to clean up the inside.
3. Mixing the LLC
Put the LLC in cooling water in the percentage (%) for a target temperature. When mixing, stir it up well, and then fill into the radiator.
4. The procedure for the mixing of water and antifreeze differs according to the make of the antifreeze and the ambient temperature. Refer to SAE J1034 standard, more specifically also to SAE J814c.

IMPORTANT :

- When the antifreeze is mixed with water, the antifreeze mixing ratio must be less than 50%.

Vol % Anti-freeze	Freezing Point		Boiling Point*	
	°C	°F	°C	°F
40	-24	-12	106	222
50	-37	-34	108	226

* At 1.013×10^5 Pa (760mmHg) pressure (atmospheric). A higher boiling point is obtained by using a radiator pressure cap which permits the development of pressure within the cooling system.

5. Adding the LLC
 - (1) Add only water if the mixture reduces in amount by evaporation.
 - (2) If there is a mixture leak, add the LLC of the same manufacturer and type in the same mixture percentage.
 - * Never add any long-life coolant of different manufacturer. (Different brands may have different additive components, and the engine may fail to perform as specified.)
6. When the LLC is mixed, do not employ any radiator cleaning agent. The LLC contains anticorrosive agent. If mixed with the cleaning agent, sludge may build up, adversely affecting the engine parts.
7. Kubota's genuine long-life coolant has a service life of 2 years. Be sure to change the coolant every 2 years.

NOTE :

- The above data represent industry standards that necessitate a minimum glycol content in the concentrated antifreeze.
- When the coolant level drops due to evaporation, add water only to keep the antifreeze mixing ratio less than 50%. In case of leakage, add antifreeze and water in the specified mixing ratio before filling in to the radiator.

■ Replacing Radiator Hose (Water pipes)

Replace the hoses and clamps.
(See "Checking Radiator Hose and Clamp" in every 200 hours maintenance)

■ Replacing Power Steering Hose

Consult your local KUBOTA Dealer for this service.

■ Replacing Fuel Lines

Consult your local KUBOTA Dealer for this service.

■ Replacing Intake Air Line

Consult your local KUBOTA Dealer for this service.

SERVICE AS REQUIRED

■ Bleeding Fuel System

Air must be removed:

1. When the fuel filter or lines are removed.
2. When the tank is completely empty.
3. After the tractor has not been used for a long period of time.

◆ Bleeding procedure is as follows:

1. Fill the fuel tank with fuel.

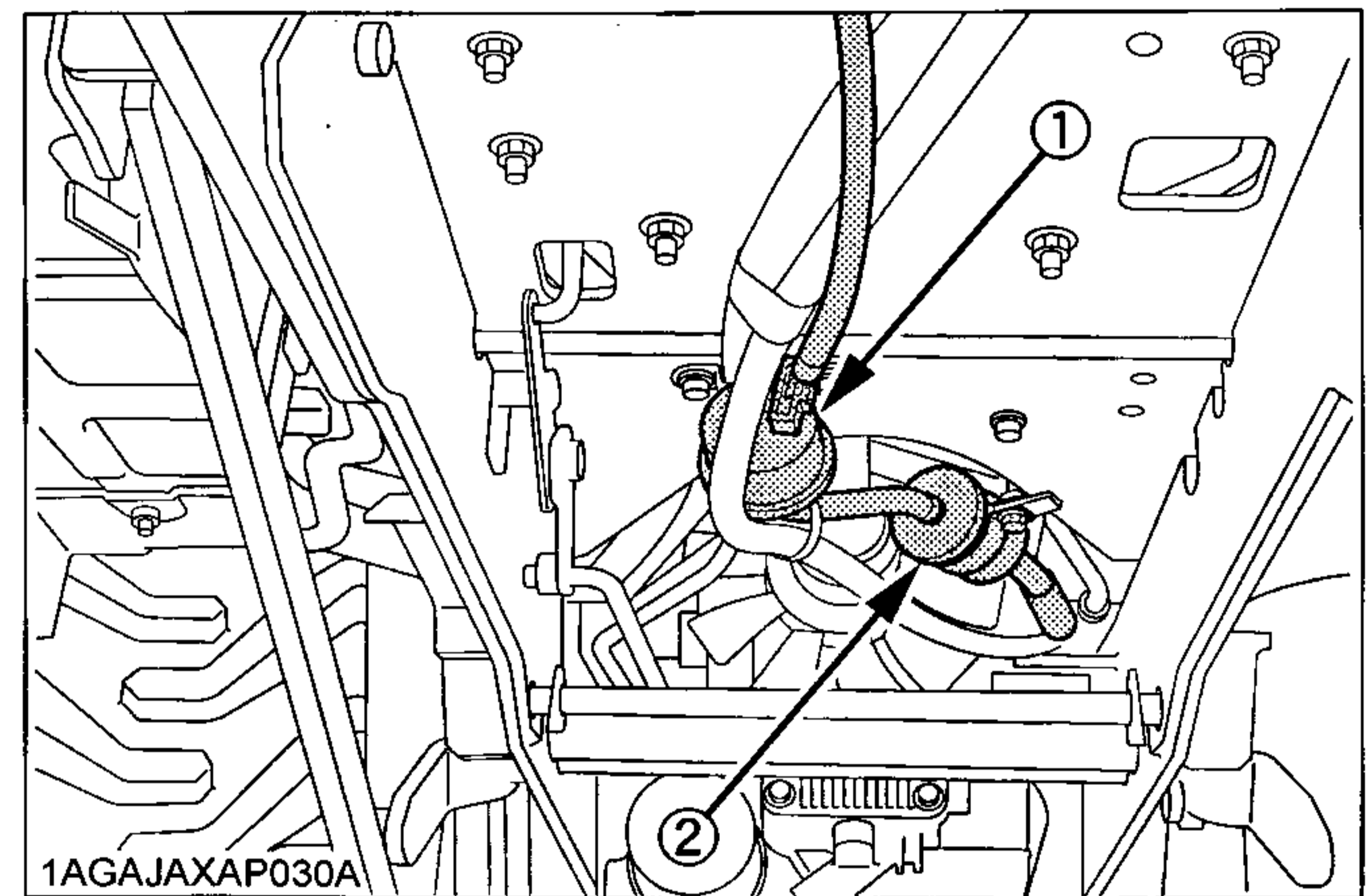

(1) Fuel pump
(2) Fuel filter

2. Turn the key switch to "ON" position for about 30 seconds. Doing so allows fuel pump to work and pump air out of the fuel system.
3. Start the engine and run for about 30 seconds, and then stop the engine.

■ Replacing Fuse

The tractor electrical system is protected from potential damage by fuses.

A blown fuse indicates that there is an overload or short somewhere in the electrical system.

If any of the fuses should blow, replace with a new one of the same capacity.

IMPORTANT :

- Before replacing a blown fuse, determine why the fuse blew and make any necessary repairs. Failure to follow this procedure may result in serious damage to the tractor electrical system. Refer to the troubleshooting section of this manual or your local KUBOTA Dealer for specific information dealing with electrical problems.

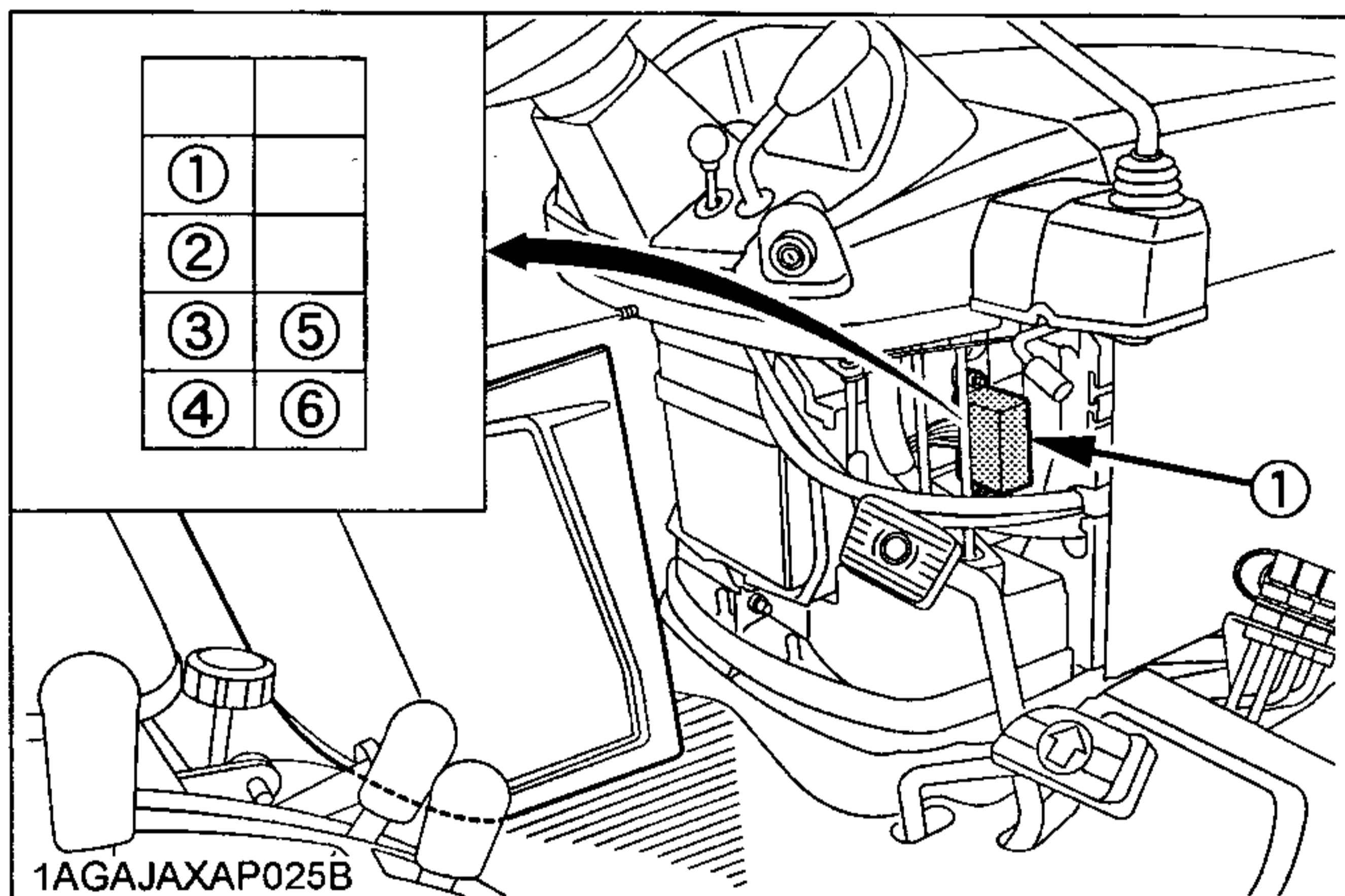

(1) Fuse box

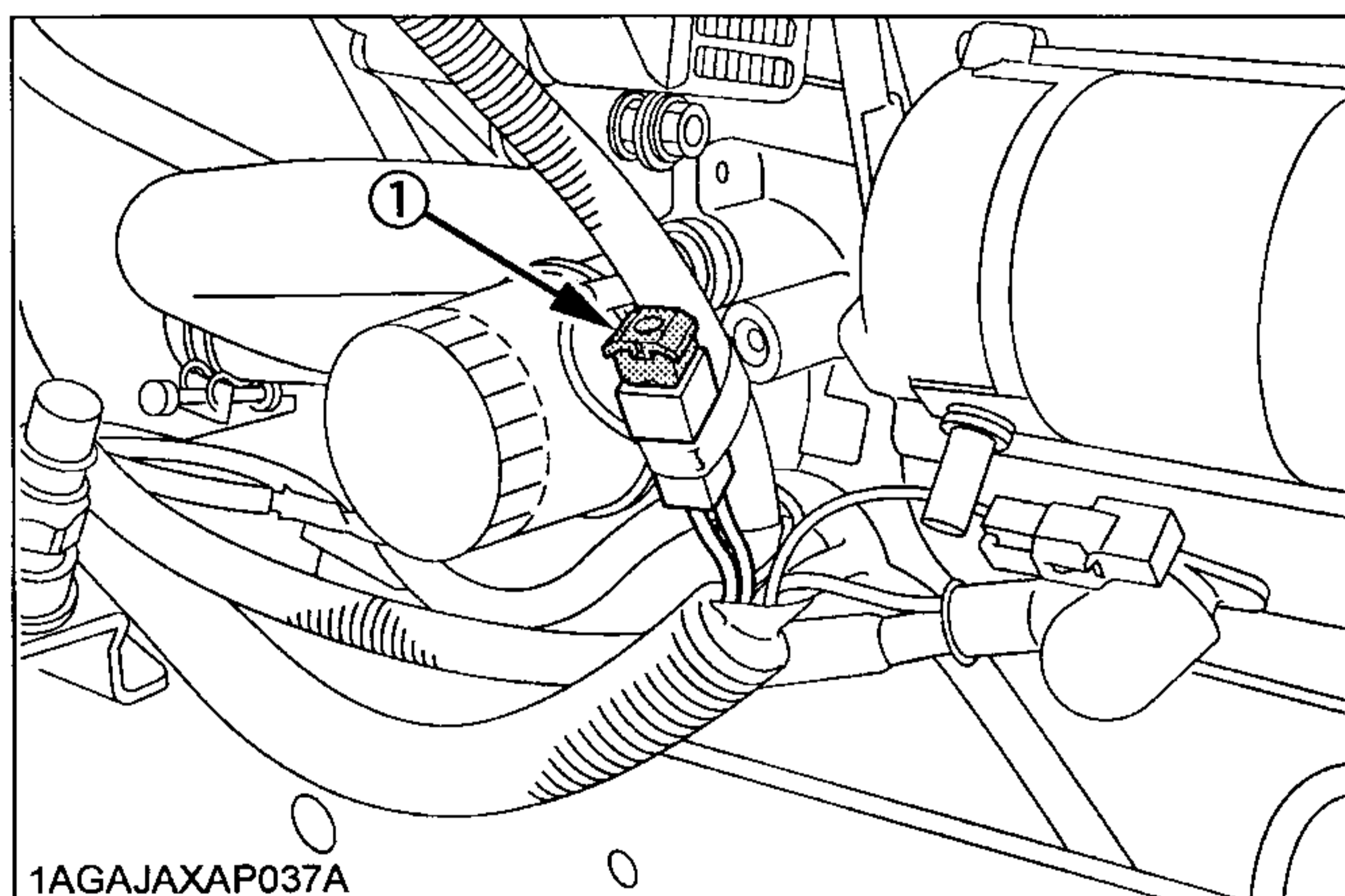

(1) Slow blow fuse

◆ Protected circuit

[Fuse box]

FUSE No.	CAPACITY (A)	Protected circuit
(1)	15	SOLENOID
(2)	15	HAZARD
(3)	15	ACC
(4)	20	WORKING LIGHT
(5)	10	DC OUTLET
(6)	10	TIMER RELAY

CAPACITY (A)	Protected circuit
Slow blow Fuse (50A)	Check circuit against wrong battery connection

■ Replacing Light Bulb

1. Head lights.
Take the bulb out of the light body and replace with a new one.
2. Other lights
Detach the lens and replace the bulb.

Light	Capacity
Headlights	37.5W
Tail light	12.8W
Hazard light	23W

STORAGE



CAUTION

To avoid personal injury:

- Do not clean the machine while the engine is running.
- To avoid the danger of exhaust fume poisoning, do not operate the engine in a closed building without proper ventilation.
- When storing, remove the key from the key switch to avoid unauthorized persons from operating the tractor and getting injured.

TRACTOR STORAGE

If you intend to store your tractor for an extended period of time, follow the procedures outlined below. These procedures will insure that the tractor is ready to operate with minimum preparation when it is removed from storage.

1. Check the bolts and nuts for looseness, and tighten if necessary.
2. Apply grease to tractor areas where bare metal will rust also to pivot areas.
3. Detach the weights from the tractor body.
4. Inflate the tires to a pressure a little higher than usual.
5. Change the engine oil and run the engine to circulate oil throughout the engine block and internal moving parts for about five minutes.
6. With all implements lowered to the ground, coat any exposed hydraulic cylinder piston rods with grease.
7. Remove the battery from the tractor. Store the battery following the battery storage procedures.
(See "Battery condition" in every 100 hours in periodic service section.)
8. Keep the tractor in a dry place where the tractor is sheltered from the elements. Cover the tractor.
9. Store the tractor indoors in a dry area that is protected from sunlight and excessive heat. If the tractor must be stored outdoors, cover it with a waterproof tarpaulin. Jack the tractor up and place blocks under the front and rear axles so that all four tires are off the ground. Keep the tires out of direct sunlight and extreme heat.

IMPORTANT :

- When washing the tractor, be sure to stop the engine. Allow sufficient time for the engine to cool before washing.
- Cover the tractor after the muffler and the engine have cooled down.

REMOVING THE TRACTOR FROM STORAGE

1. Check the tire air pressure and inflate the tires if they are low.
2. Jack the tractor up and remove the support blocks from under the front and rear axles.
3. Install the battery. Before installing the battery, be sure it is fully charged.
4. Check the fan belt tension.
5. Check all fluid levels (engine oil, transmission/hydraulic oil, engine coolant and any attached implements).
6. Start the engine. Observe all gauges. If all gauges are functioning properly and reading normal, move the tractor outside. Once outside, park the tractor and let the engine idle for at least five minutes. Shut the engine off and walk around tractor and make a visual inspection looking for evidence of oil or water leaks.
7. With the engine fully warmed up, release the parking brake and test the brakes for proper adjustment as you move forward. Adjust the brakes as necessary.

TROUBLESHOOTING

ENGINE TROUBLESHOOTING

If something is wrong with the engine, refer to the table below for the cause and its corrective measure.

Trouble		Cause	Countermeasure
Engine is difficult to start or won't start.		<ul style="list-style-type: none"> No fuel flow. 	<ul style="list-style-type: none"> Check the fuel tank and the fuel filter. Replace filter if necessary.
		<ul style="list-style-type: none"> Air or water is in the fuel system. 	<ul style="list-style-type: none"> Check to see if the fuel line coupler bolt and nut are tight. Bleed the fuel system. (See "Bleeding Fuel System" in "SERVICE AS REQUIRED" Section.) Remove water from the system and replace the fuel filter.
		<ul style="list-style-type: none"> In winter, oil viscosity increases, and engine revolution is slow. 	<ul style="list-style-type: none"> Use oils of different viscosities, depending on ambient temperatures. Use engine block heater. (Option)
		<ul style="list-style-type: none"> Battery becomes weak and the engine does not turn over quick enough. 	<ul style="list-style-type: none"> Clean battery cables and terminals. Charge the battery. In cold weather, always remove the battery from the engine, charge and store it indoors. Install it on the tractor only when the tractor is going to be used.
Insufficient engine power.		<ul style="list-style-type: none"> Insufficient or dirty fuel. The air cleaner is clogged. 	<ul style="list-style-type: none"> Check the fuel system. Clean or replace the element.
Engine stops suddenly.		<ul style="list-style-type: none"> Insufficient fuel. 	<ul style="list-style-type: none"> Refuel. Bleed the fuel system if necessary.
Exhaust fumes are colored.	Black	<ul style="list-style-type: none"> Fuel quality is poor. Too much oil. The air cleaner is clogged. 	<ul style="list-style-type: none"> Change the fuel and fuel filter. Check the proper amount of oil. Clean or replace the element.
	Blue white	<ul style="list-style-type: none"> The inside of exhaust muffler is dumped with fuel. Injection nozzle trouble. Fuel quality is poor. 	<ul style="list-style-type: none"> Heat the muffler by applying load to the engine. Check the injection nozzle. Change the fuel and fuel filter.
Engine overheats.		<ul style="list-style-type: none"> Engine overloaded. 	<ul style="list-style-type: none"> Shift to lower gear or reduce load.
		<ul style="list-style-type: none"> Low coolant level. 	<ul style="list-style-type: none"> Fill cooling system to the correct level; check radiator and hoses for loose connections or leaks.
		<ul style="list-style-type: none"> Loose or defective fan belt. 	<ul style="list-style-type: none"> Adjust or replace fan belt.
		<ul style="list-style-type: none"> Dirty radiator core or grille screens. 	<ul style="list-style-type: none"> Remove all trash.
		<ul style="list-style-type: none"> Coolant flow route corroded. 	<ul style="list-style-type: none"> Flush cooling system.

If you have any questions, contact your local KUBOTA Dealer.

OPTIONS

Consult your local KUBOTA Dealer for further detail.

- 16 x 7.5-8 Bar Tire [BX1850]
- 24 x 12.0-12 Bar Tire [BX1850]
- 18 x 8.5-10 Bar Tire [BX2350]
- 26 x 12.0-12 Bar Tire [BX2350]
- 18 x 8.5-10 Ind. Tire [BX2350]
- 26 x 12.0-12 Ind. Tire [BX2350]
- Grille guard
- Engine Block heater
 - For facilitating starting and reducing warm up period in cold weather.
- Rear Work Light
 - High visibility for night work
- Front end weights
 - For front ballast
- Rear wheel weight
- Sunshade for ROPS
- Dual-Double Acting Remote Valve
- Ballast Box
- Male Quick Hitch
- Mid PTO Driveline
 - Chute Rotator
 - Chute Deflector
 - Sweeper

KUBOTA Corporation is . . .

Since its inception in 1890, KUBOTA Corporation has grown to rank as one of the major firms in Japan.

To achieve this status, the company has through the years diversified the range of its products and services to a remarkable extent. Nineteen plants and 16,000 employees produce over 1,000 different items, large and small.

All these products and all the services which accompany them, however, are unified by one central commitment. KUBOTA makes products which, taken on a national scale, are basic necessities. Products which are indispensable. Products which are intended to help individuals and nations fulfill the potential inherent in their environment. KUBOTA is the Basic Necessities Giant.

This potential includes water supply, food from the soil and from the sea, industrial development, architecture and construction, and transportation.

Thousands of people depend on KUBOTA's know-how, technology, experience and customer service. You too can depend on KUBOTA.

Kubota

- U.S.A. : **KUBOTA TRACTOR CORPORATION**
3401 Del Amo Blvd., Torrance, CA 90503, U.S.A.
Telephone : (310)370-3370
- Western Division : 1175 S. Guild Av., Lodi, CA 95240
Telephone : (209)334-9910
- Central Division : 14855 FAA Blvd., Fort Worth, TX 76155
Telephone : (817)571-0900
- Northern Division : 6300 at One Kubota Way, Groveport, OH 43125
Telephone : (614)835-1100
- Southeast Division : 1025 Northbrook Parkway, Suwanee, GA 30024
Telephone : (770)995-8855
- Canada : **KUBOTA CANADA LTD.**
5900 14th Avenue, Markham, Ontario, L3S 4K4, Canada
Telephone : (905)294-7477
- Delta Distribution Center : 7979 82nd St, Delta B.C. V4G 1L7
Telephone : (604)940-6061
- Drummondville Distribution Center : 5705 Place Kubota, Drummondville, Québec, J2B 6B4
Telephone : (819)478-7151
- France : **KUBOTA EUROPE S.A.S**
19-25, Rue Jules Vercurysse, Z.I. BP88, 95101 Argenteuil Cedex, France
Telephone : (33)1-3426-3434
- Italy : **KUBOTA EUROPE S.A.S Italy Branch**
Via Grandi, 29 20068 Peschiera Borrome (MI) Italy
Telephone : (39)02-51650377
- Germany : **KUBOTA (DEUTSCHLAND) GmbH**
Senefelder Str. 3-5 63110 Rodgau / Nieder-Roden, Germany
Telephone : (49)6106-873-0
- U.K. : **KUBOTA (U.K.) LTD.**
Dormer Road, Thame, Oxfordshire, OX9 3UN, U.K.
Telephone : (44)1844-214500
- Spain : **KUBOTA ESPAÑA S.A.**
Ctra, Del Barrio de la Fortuna s/n Cuatro Vientos 28044 Madrid, Spain
Telephone : (34)91-508-6442
- Australia : **KUBOTA TRACTOR AUSTRALIA PTY LTD.**
100 Keilor Park Drive, Tullamarine, Victoria 3043 Australia
Telephone : (61)-3-9279-2000
- Malaysia : **SIME KUBOTA SDN. BHD.**
No.3 Jalan Sepadu 25/123 Taman Perindustrian Axis,
Seksyen 25, 40400 Shah Alam, Selangor Darul Ehsan Malaysia
Telephone : (60)3-736-1388
- Philippines : **KUBOTA AGRO-INDUSTRIAL MACHINERY PHILIPPINES, INC.**
155 Panay Avenue, South Triangle Homes, 1103 Quezon City, Philippines
Telephone : (63)2-9201071
- Taiwan : **SHIN TAIWAN AGRICULTURAL MACHINERY CO., LTD.**
16, Fengping 2nd Rd, Taliiao Shiang Kaohsiung 83107, Taiwan R.O.C.
Telephone : (886)7-702-2333
- Indonesia : **P.T. KUBOTA INDONESIA**
JALAN. Setyabudi 279, Semarang, Indonesia
Telephone : (62)-24-7472849
- Thailand : **THE SIAM KUBOTA INDUSTRY CO., LTD.**
101/19-24 Navanakorn, Tambol Klongneung, Amphur Klongluang, Pathumtani 12120, Thailand
Telephone : (66)2-529-0363

KUBOTA Corporation

Code No. K2581-7121-2

B
X
1
8
5
0
·
B
X
2
3
5
0
0

A