

OPERATORS MANUAL

F2000

ABBREVIATIONS LIST

Abbreviations	Definitions
4WD	Four Wheel Drive
API	American Petroleum Institute
ASAE	American Society of Agricultural Engineers, USA
ASTM	American Society for Testing and Materials, USA
DT	Dual Traction (4WD)
HST	Hydrostatic Transmission
PT	Permanent Type (=Ethylene glycol anti-freeze)
PTO	Power Take Off
ROPS	Roll-Over Protective Structures
rpm	Revolutions Per Minute
r/s	Revolutions Per Second
SAE	Society of Automotive Engineers, USA
SPT	Semi-Permanent Type
UDT	KUBOTA UDT fluid (Transmission-hydraulic fluid)



SAFETY FIRST

This symbol, the industry's "Safety Alert Symbol", is used throughout this manual and on labels on the front mower itself to warn of the possibility of personal injury. Read these instructions carefully. It is essential that you read the instructions and safety regulations before you attempt to assemble or use this unit.

FOREWORD

You are now the proud owner of a KUBOTA F2000 FRONT MOWER.

This front mower is a product of Kubota quality engineering and manufacturing. It is produced under a rigid quality control system using the finest materials, and will provide long, satisfactory service. To obtain the best use of your front mower, please read this manual carefully. It will help you become familiar with the operation of the front mower and contains useful information about the front mower's maintenance. It is Kubota's policy to utilize every advance in our research as quickly as possible. The immediate use of new techniques in the manufacture of products may cause some small parts of this manual to become outdated.

Kubota distributors and dealers will have the most up-to-date information. Please do not hesitate to consult with them.

CONTENTS

 Safe Operation	1
1. Servicing of Front Mower	5
2. Specifications	6
2.1 Specification table	6
3. Operating New Front Mower	7
4. Instrument Panel and Controls	8
4.1 Switches	8
4.2 Controls	11
5. Lift Link and Hydraulic control	15
6. Wheels, Tires and Ballast	17
6.1 Wheel adjustment	17
6.2 Tires	18
6.3 Ballast	18
6.4 Toe-in	18
7. Operation	19
7.1 Operating the Engine	19
7.2 Operating the Front Mower	20
7.3 Check During Driving	22
8. Maintenance	23
8.1 Daily Check	23
8.2 Lubricants	23
8.3 Maintenance Check List	24
9. Check and Maintenance	25
9.1 Fuel	25
9.2 Engine Oil	26
9.3 Transmission Fluid	27
9.4 Changing Rear Axle Differential Case Oil	29
9.5 Changing Rear Axle Gear Case Oil (Right and Left)	29
9.6 Oiling and Greasing Points before Starting	29
9.7 Radiator	30
9.8 Air Cleaner	32
9.9 Cleaning Air Filter Element	32
9.10 Battery	32
9.11 Fuse	34
10. Adjustments	35
10.1 Fan Drive Belt	35
10.2 Clutch	35
10.3 Brake	35
11. Troubleshooting	36
11.1 Engine Troubleshooting	36
11.2 Front Mower Troubleshooting	37
11.3 Battery Troubleshooting	38
12. Long-Term Storage	39
13. Lubricant specifications	40
14. Wiring Diagram	41
Index	42



SAFE OPERATION

Careful operation is your best insurance against an accident. Read this section carefully before operating the front mower. All operators, whether experienced or not, should read this and other related manuals before operating the mower or any attachment on it. It is the owner's legal obligation to instruct all operators in safe operation.

1. BEFORE OPERATING THE FRONT MOWER

- (1) Know your equipment and its limitations. Read this entire manual before attempting to start and operate the front mower.
- (2) Pay special attention to the warning, caution and danger labels on the front mower itself. It is the owner's legal obligation to keep these labels clean and to replace any that are missing, illegible, or damaged.
- (3) Kubota recommends the use of a ROPS (Roll Over Protective Structure) and seat belt in almost all applications. This combination will reduce the risk of serious injury or death should the front mower tip over. Never modify or repair a ROPS. Welding, bending, drilling or cutting any portion of the ROPS will weaken the ROPS structure. A damaged ROPS structure must be replaced, not repaired or revised. If any structural member is damaged, replace the entire structure at your local Kubota dealer.

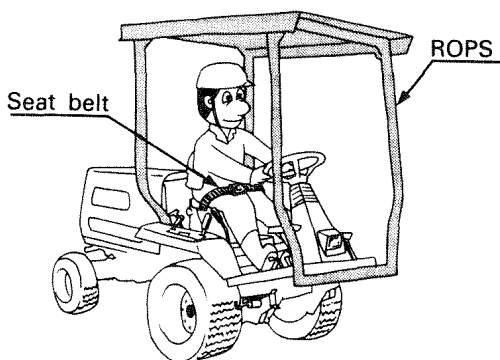

G-2627

- (4) Always use the seat belt if the front mower has a ROPS. Never fasten the seat belt without a ROPS. Check the seat belt daily and replace if frayed or damaged.
- (5) Do not operate the front mower or any attachments while under the influence of alcohol, medication, controlled substances or when fatigued.
- (6) Carefully check the immediate area before operating the front mower or any attachments on it. Check for overhead clearance that may interfere with the ROPS. Do not allow any bystanders around or near front mower during operation.
- (7) Before allowing other people to use your front mower, explain how to operate and have them read this manual before operation.

- (8) Never wear loose, torn, or bulky clothing around front mower. The clothing may catch on moving parts or controls. Wear and use any additional safety items such as hard hat, safety boots or shoes, eye and hearing protection, gloves, etc. As appropriate or required.
- (9) Do not allow passengers, children or non-qualified operators on the front mower at any time. The operator must remain in the front mower seat throughout operation.
- (10) Check brakes, clutch, and other mechanical parts for correct adjustment and wear. Replace worn or damaged parts promptly. Check the tightness of all nuts and bolts regularly. (For further details, see MAINTENANCE AND ADJUSTMENTS section.)
- (11) Keep your front mower clean. Accumulations of dirt, grease, and trash can contribute to fires and lead to personal injury.

2. OPERATING THE FRONT MOWER

- (1) Always sit in the operator's seat when starting engine or operating levers or controls.
- (2) Before starting the engine make sure that all levers are in neutral, the parking brake is engaged, and the clutch and Power Take Off are both disengaged. Fasten the seat belt if the front mower has a ROPS.
- (3) Do not start engine by shorting across starter terminals. The front mower may start in gear and move if normal starting circuitry is bypassed.
- (4) Do not operate or idle engine in a non-ventilated area. Carbon monoxide gas is colorless, odorless, and deadly.
- (5) Keep all shields and guards in place. Replace any that are damaged or missing.
- (6) To avoid tipover, slow down when turning, on uneven terrain, or before stopping.
- (7) Do not operate near ditches, holes, embankments, or other terrain which may collapse under the front mower weight. The risk of front mower tipover increases when the ground is loose or wet.
- (8) To avoid tipover, operate up and down slopes, not across. Avoid sudden starts and stops on slopes. Slow down, and use extra caution when changing directions on a slope.
Park the front mower on a firm, level surface.
- (9) Watch where you are going at all times. Watch for and avoid obstacles. Be alert at curbs, near trees, and other obstructions and hidden hazards.

- (10) When working in cooperation with other operators, always let others know what you are doing ahead of time.
- (11) Never try to mount or dismount a moving front mower.
- (12) Do not operate the front mower with bare feet. Keep hands, feet, and clothing away from power-driven parts.
- (13) To avoid tipover when turning, do not apply one brake at high speeds. Lock the two brake pedals together to help insure straightline stops.
- (14) Do not attempt to turn the front mower with the differential locked.
- (15) Do not drive front mower on streets or highways. Watch for traffic when you cross roads or operate near roads.
- (16) Use extra caution when backing up the front mower.
- (17) Do not cross gravel roads with the PTO engaged.

3. STOPPING THE FRONT MOWER

- (1) Before dismounting, disengage the PTO, lower the attachment, place all control levers in their neutral positions, apply parking brake, turn off the engine, and remove the key switch.
- (2) Make sure the front mower has come to a complete stop before dismounting.

4. USING THE PTO

- (1) Before installing or using PTO-driven equipment, read the manufacturer's manual and review the safety labels attached to the equipment.
- (2) Wait until all moving components have completely stopped before connecting, disconnecting, adjusting, cleaning, or servicing any PTO-driven equipment.
- (3) Do not use the PTO with unauthorized attachments. The front mower has two PTO speeds, the first speed (1,100rpm) is for a Kubota Snow Blower Attachment and the 2nd speed (2,500rpm) is for a Kubota Mower Deck Attachment.

5. USING THE LIFT LINK

- (1) Use lift link only with authorized attachments designed for lift link usage.
- (2) When using a lift link mounted attachment, be sure to install the adequate counter ballast weight specified in the attachment's manual.

6. SERVICING THE FRONT MOWER

- (1) Before servicing, park the front mower on a firm, level surface and apply the parking brake. Remove the ignition key to prevent accidental start-up.
- (2) Attach mower 2 point lock link before servicing the mower deck.
- (3) Allow the front mower time to cool before touching the engine, muffler, radiator, etc.
- (4) Always stop the engine before refueling. Avoid spills and overfilling.

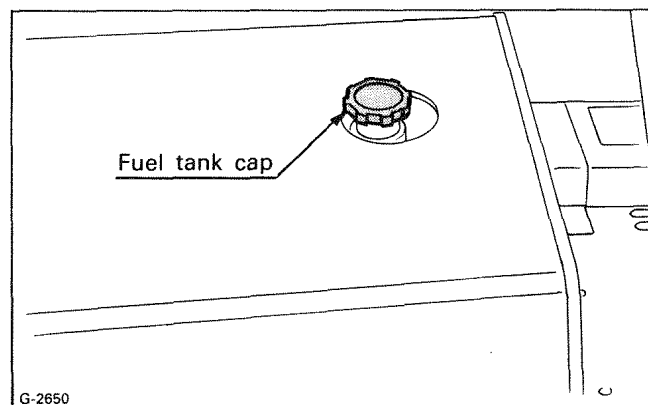

- (5) Do not smoke when working around battery or when refueling. Keep all sparks and flames away from battery and fuel tank. A battery, especially when charging, will give off hydrogen and oxygen gases which can explode and cause serious personal injury.
- (6) Before "jumping" a dead battery, read and follow all the instructions. (See page 3)
- (7) Keep first aid kit and fire extinguisher handy at all times.
- (8) Do not remove the radiator cap while coolant is hot. When cool, slowly rotate cap to the first stop and allow sufficient time for excess pressure to escape before removing the cap completely.
- (9) Disconnect the battery's ground cable before working on or near electric components.
- (10) To avoid sparks from an accidental short circuit, always disconnect the battery's ground cable (-) first and re-connect it last.

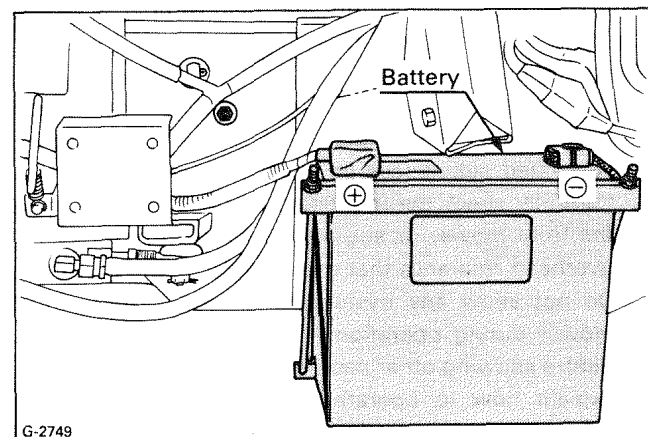

- (11) Do not attempt to mount a tire on a rim unless qualified to do so and all proper safety precautions are followed.
- (12) Provide adequate support when changing wheels or the wheel tread width.
- (13) Make sure that wheel bolts have been tightened to the specified torque.
- (14) Escaping hydraulic fluid under pressure has sufficient force to penetrate into skin, causing serious personal injury. Before disconnecting hydraulic lines, be sure to release all residual pressure. Before applying pressure to the hydraulic system, make sure that all connections are tight and that all lines, pipes, and hoses are free of damage.

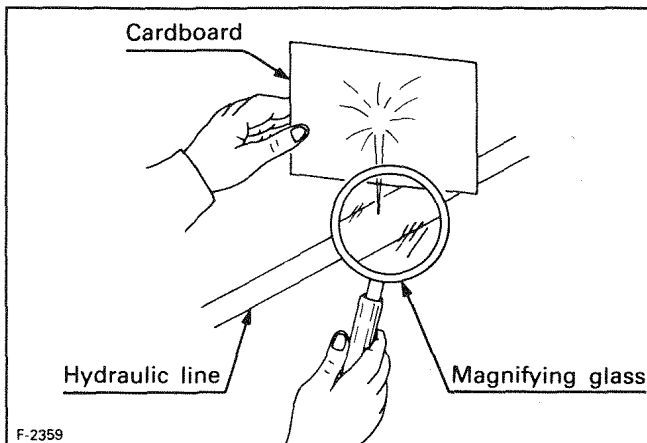

Fluid escaping from pinholes may be invisible. Use a piece of cardboard or wood to search for suspected leaks: do not use hands. Use safety goggles or other eye protection. If injured by escaping fluid, see a medical doctor at once.

Serious infection or reaction may result if proper medical treatment is not administered immediately.

7. JUMP STARTING INSTRUCTIONS AND PRECAUTIONS

If ice is present or the battery is cracked, DO NOT ATTEMPT TO "JUMP START" vehicle.

- (1) Bring helper vehicle with a battery of the same voltage as disabled front mower within easy cable reach. "THE VEHICLES MUST NOT TOUCH".
- (2) Engage the parking brakes of both vehicles and put the shift levers in neutral. Turn both key switches off.
- (3) Put on safety goggles and rubber gloves.
- (4) Remove the vent caps from both batteries.
- (5) Cover vent holes with damp rags. Do not allow the rag to touch the battery terminals.
- (6) Attach the red clamp to the positive (red, ⊕ or pos.) terminal of the dead battery and clamp the other end of the same cable to the positive (red, ⊕ or pos.) terminal of the helper battery.
- (7) Clamp the other cable to the negative (black, ⊖ or neg.) terminal of the helper battery.
- (8) Clamp the other end to the engine block or frame of the disabled front mower as far from the dead battery as possible.
- (9) Start the helper vehicle and let its engine run for a few moments. Start the disabled front mower.
- (10) Disconnect the jumper cables in the exact reverse order of attachment. (Steps 8,7 and 6).
- (11) Remove and discard the damp rags. Reinstall the vent caps.

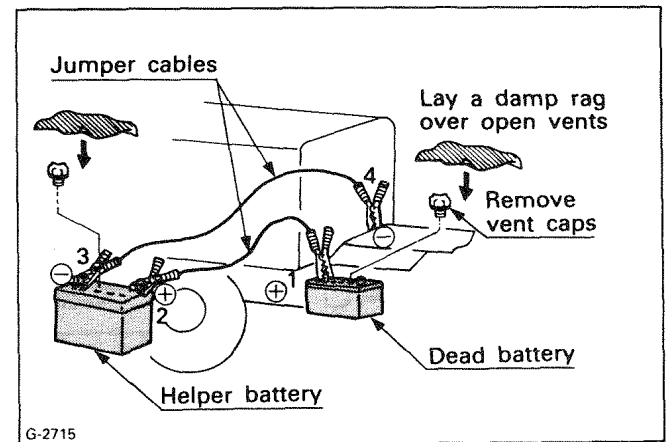

Connect cables in numerical order.
Disconnect in reverse order after use.

8. FRONT MOWER SAFETY LABELS

① Part No. 66041—4713—3

⚠ CAUTION

TO AVOID PERSONAL INJURY:

1. Read Operator's Manual.
2. Know location and function of all controls.
3. Keep safety devices (guards, shields, and switches) in place and working.
4. Remove objects that could be thrown by blade.
5. Before starting engine, make certain PTO is OFF and everyone is at a safe distance from machine.
6. Never permit passengers on tractor.
7. Always look behind machine before backing.
8. Do not operate where machine could tip or slip.
9. If machine stops going uphill, stop blade and back slowly down.
10. Be sure blade and engine are stopped before placing hands or feet near blade.
11. Before dismounting, turn off Front PTO, lower implement, shift into neutral, set parking brake, stop engine and remove the key.
12. This tractor is not for street or highway use.

② Part No. 67061—4724—1

⚠ WARNING

Do not start engine with speed set lever or speed control pedal engaged.

③ Part No. 35820—9863—1

⚠ WARNING

AVOID POSSIBLE INJURY OR DEATH FROM A MACHINE RUNAWAY:

1. Do not start engine by shorting across starter terminals. Machine may start in gear and move if normal starting circuitry is bypassed.
2. Start engine only from operator's seat with transmission and PTO in neutral.
NEVER start engine while standing on ground.

④ Part No. 35260—2978—1

⚠ CAUTION

TO AVOID PERSONAL INJURY:

1. Roll-Over Protective Structure (ROPS) with a seat belt is recommended by KUBOTA in most applications. Check operator's manual and discuss with your local dealer.
2. Always use seat belt when the tractor is equipped with Roll-Over Protective Structure (ROPS). Never use seat belt when the tractor is not equipped with ROPS.

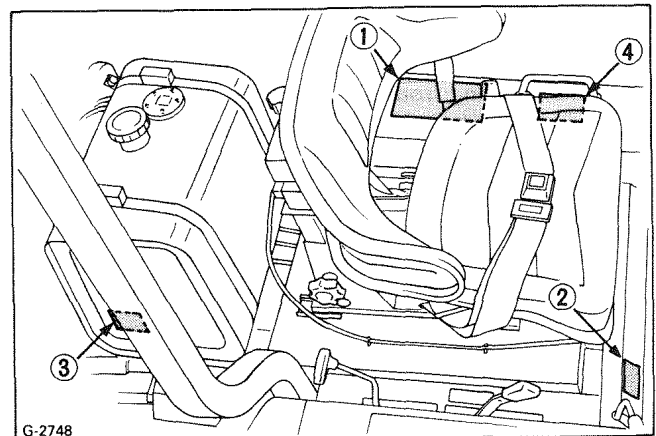

CARE OF SAFETY LABELS

- (1) Keep safety labels clean and free from obstructing material.
- (2) Clean safety labels with soap and water, dry with a soft cloth.
- (3) Replace damaged or missing safety labels with new labels from your Kubota dealer.
- (4) If a component with safety label(s) affixed is replaced with a new part, make sure new safety label(s) is(are) attached in the same location(s) as the replaced components.
- (5) Mount new safety labels by applying on a clean, dry surface and pressing any bubbles to outside edge.

1. SERVICING OF FRONT MOWER

Your dealer is interested in your new front mower and has the desire to help you get the most value from it. After reading this manual thoroughly, you will find that you can do some of the regular maintenance yourself.

However, when in need of parts or major service, be sure to see your KUBOTA dealer.

For service, contact the KUBOTA Dealership from which you purchased your front mower or your local authorized KUBOTA dealer.

When in need of parts, be prepared to give your dealer both the front mower and engine product identification numbers. The front mower product identification number is located on the transmission housing on the left-hand side of the front mower. The engine product identification number is located on the engine crankcase, left side. Locate the product identification numbers now and record them in the space provided.

KUBOTA F2000

Front Mower Product Identification No. _____

Engine Product Identification No. _____

Date of Purchase _____

(To be filled in by purchaser)

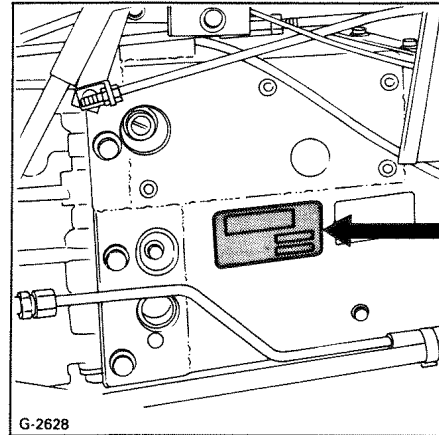

Front mower
product
identification
number

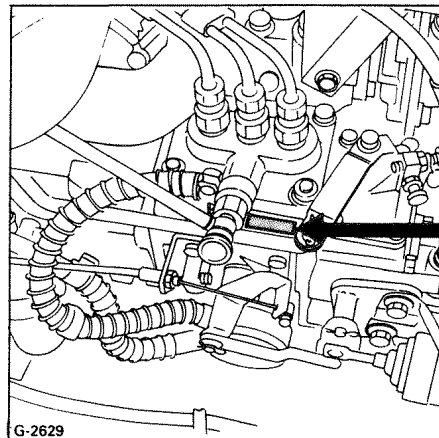

Engine
product
identification
number

2. SPECIFICATIONS

2.1 SPECIFICATION TABLE

Model		F2000	
Engine gross power (SAE)		20 HP (14.9 kW)* ¹	
Engine	Model	D950—FM	
	Type	Vertical, water-cooled, 4-cycle diesel	
	No. of cylinders	3	
	Bore and stroke	3.0 in X 2.8 in (75 mm X 70 mm)	
	Total displacement	56.6 cu.in. (927 cm ³)	
	Rated revolution	2600 rpm (43.3 r/s)	
	Fuel	Diesel fuel No. 2—D [No.1 diesel fuel, if temperature is below -10°C (15°F)]	
	Starter	Electric starter with battery, glow plug, 12V, 0.8 kW	
	Lubrication	Forced lubrication by trochoidal pump	
	Cooling	Water with pressurized radiator	
	Battery	12V (65 Ah)	
	Capacities	Fuel tank	9.0 U.S.gals. (34 ℓ)
Engine crankcase		3.3 U.S.qts. (3.1 ℓ)	
Engine coolant		3.9 U.S.qts. (3.7 ℓ)	
Transmission case		13.4 U.S.qts. (12.7 ℓ)	
Rear axle diff. case		1.6 U.S.qts. (1.5 ℓ)	
Rear axle gear case		0.5 U.S.qts. (0.5 ℓ)	
Tires	Front	23X10.50—12 (4PR) Turf	
	Rear	16X6.50—8 (4PR) Turf	
Traveling speeds	Forward	Low	4.6 mph (7.4 km/h) * ²
		High	9.5 mph (15.2 km/h) * ²
	Reverse	Low	2.8 mph (4.4 km/h) * ²
		High	5.6 mph (9.0 km/h) * ²
Dimensions	Overall length	86.2 in (2190 mm)	
	Overall width	44.9 in (1140 mm)	
	Overall height	49.6 in (1260 mm)	
	Wheelbase	48.6 in (1235 mm)	
	Min. ground clearance	6.9 in (175 mm)	
	Treads	Front	34.4 in (875 mm) • 36.8 in (935 mm)
	Rear	34.3 in (870 mm)	
Weight	1380 lbs (625 kg) (W/O mower deck)		
PTO shaft	Transmission case front		
Front PTO	Kubota 10 tooth Involute spline 2 speeds (1130 and 2550 rpm at 2600 engine rpm) (18.9 and 42.5 r/s at 43.3 engine r/s)		
Clutch	Dry single		
Steering	Power, hydrostatic		
Transmission	Main-hydrostatic transmission, High-Low gear shift (2 forward, 2 reverse)		
Min. turning radius	LH 1.7 feet (0.53 m) W/O brake		
Brake	Internal expanding type, right and left independent with interlocking device		
Differential	Bevel gear		

Note: *1 Manufacturer's estimate

*2 at 2600 engine rpm (43.3 engine r/s)

(Specifications and design subject to change without notice)

3. OPERATING NEW FRONT MOWER

The handling and maintenance of a new front mower determines the length of its service.

A new front mower just off the factory production line is carefully assembled and tested, however, extra care should be taken to operate the front mower at a slower speed for the first 100 hours. Avoid excessive loads until the various parts are well "broken-in." In order to obtain the maximum performance and the longest life of the front mower, it is very important to break-in your front mower correctly. When operating a new front mower, the following precautions should be observed.

■ Do not Operate the Front Mower at Full Speed for the First 100 Hours.

- Do not start quickly or apply the brakes suddenly.
- In winter, operate the front mower only after fully warming up the engine.
- Do not run the engine at speeds faster than necessary.
- On rough roads, slow down to suitable speeds. Do not operate the front mower at excessive speeds.

■ Changing Lubricating Oil for New Front Mowers

Lubricating oil is especially important for a new front mower. The engine parts are not "broken-in" and small metal particles may develop during operation causing engine parts to wear out or become damaged. Care should be taken to change the lubricating oil earlier than would ordinarily be required in an older machine.

For further details of oil change intervals, see check list. (See page 24)

■ Engine Break-in

After the first 35 hours of operation, change the engine oil and filter. (See page 27)

■ Machine Break-in

After the first 50 hours of operation, change the transmission fluid and the oil filter cartridge and clean the transmission strainer. (See page 27,28)

■ Read "Safe Operation"

Read the "Safe Operation" before attempting to start or operate the front mower. (See page 1~4)

4. INSTRUMENT PANEL AND CONTROLS

4.1 SWITCHES

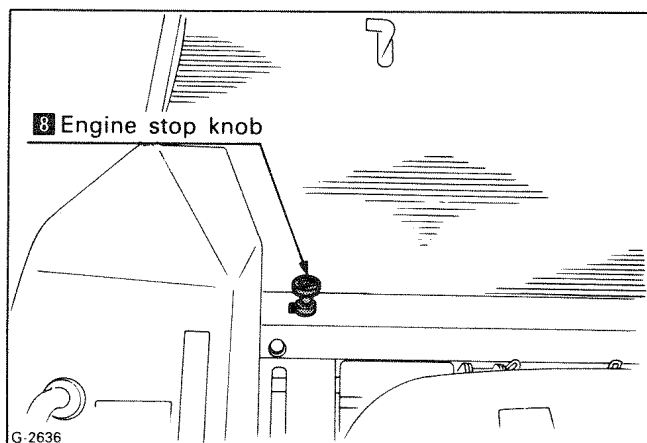
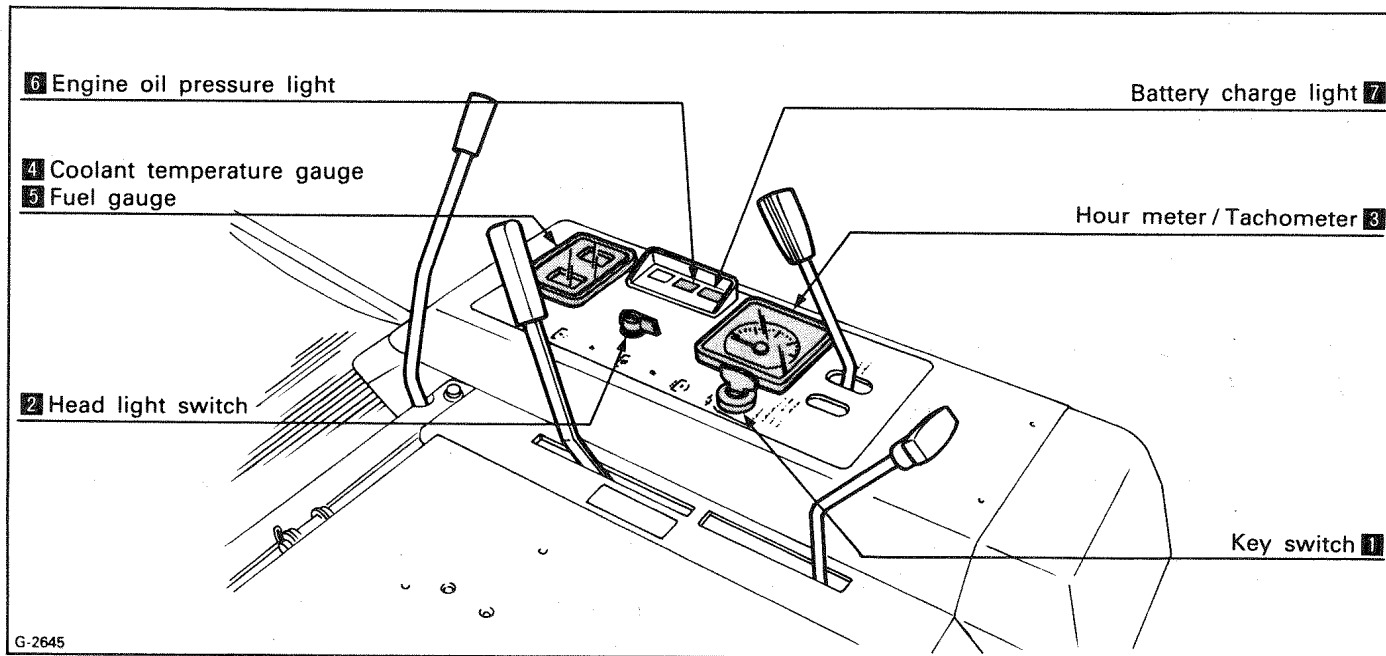

1 Key Switch



- ★ OFF.....The position in which the key can be inserted into or removed from the key switch. The engine stops the moment the key is turned to this position.
- ⚡ ON.....The engine keeps running.
- 🔥 Preheat.....The combustion chamber is heated.
- 🔧 Start.....Depress the clutch pedal fully and turn the key switch to this position to start the engine.

[IMPORTANT]

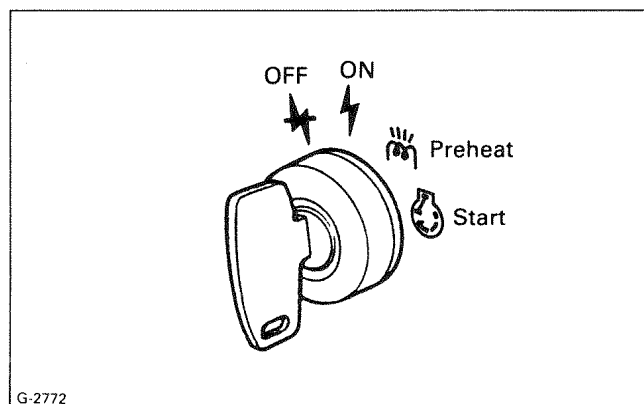
- The engine will not start if the clutch is not engaged.



2 Head Light Switch

-  Head lights ON, high beam.
-  Head lights dimmed, low beam.
-  Head lights OFF

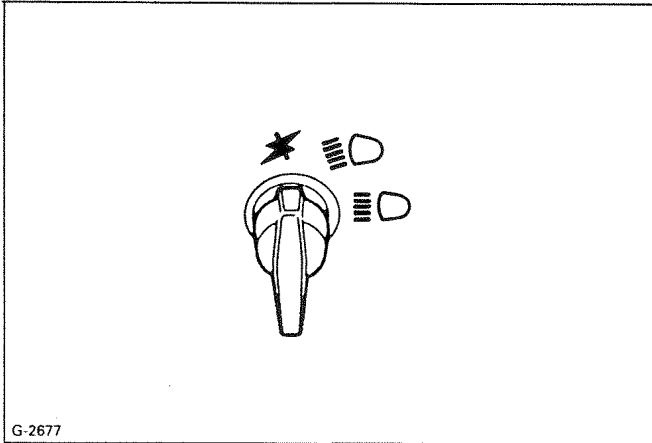

3 Hour Meter/Tachometer

This meter gives readings for engine speed and the hours the front mower has been operated.

- (1) The indicator shows the engine speed.
- (2) The hour meter indicates in five digits the number of hours the front mower has been operated; the last digit indicates 1/10 of an hour.

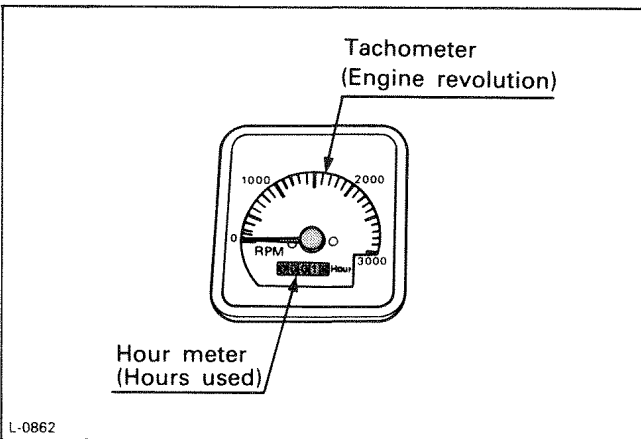

4 Coolant Temperature Gauge

- (1) With the key switch "ON", this gauge indicates the temperature of the coolant. "C" for "cold" and "H" for "hot".
- (2) If the indicator reaches the "H" setting (red zone), coolant is overheated. Stop the engine and check the coolant by referring to "Coolant". (See page 30)

5 Fuel Gauge

- The fuel gauge indicates the fuel level.

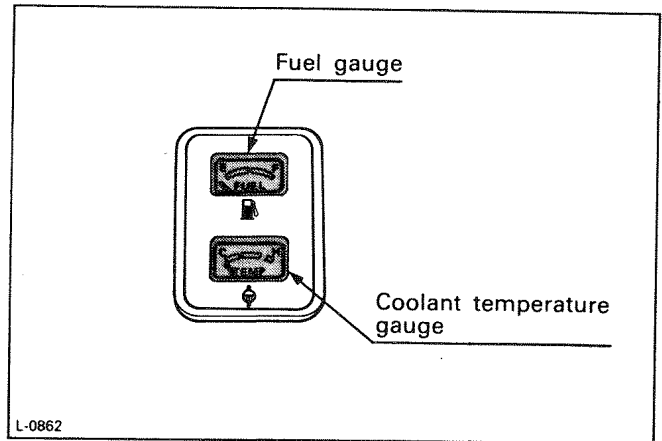

6 Engine Oil Pressure Light

The engine oil light indicates low engine oil pressure when the light is on, and proper engine oil pressure when the light is off.

The light goes on when the key switch is turned on. It goes off when the engine starts and engine oil begins to circulate normally. If the light stays on even after the engine starts, stop the engine immediately, and check the cause of the trouble.

7 Battery Charge Light

The battery charge light will illuminate when the key switch is "ON", and should dim as engine starts. If the light continues to illuminate after idling, the battery is being discharged indicating the electrical system should be checked.

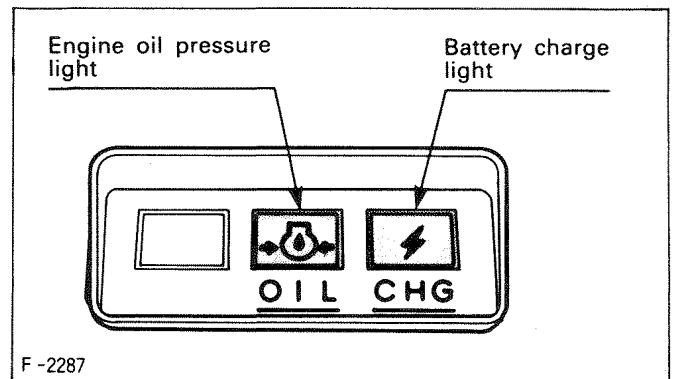

8 Engine Stop Knob

The engine stops when the key switch is turned off. If the engine does not stop, pull engine stop knob back and hold until the engine stops.

After the engine has stopped, be sure to push the stop knob in, or the engine will not start the next time.

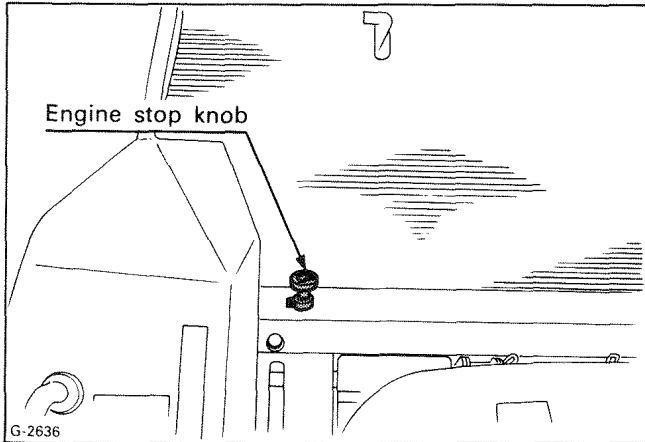

4.2 CONTROLS

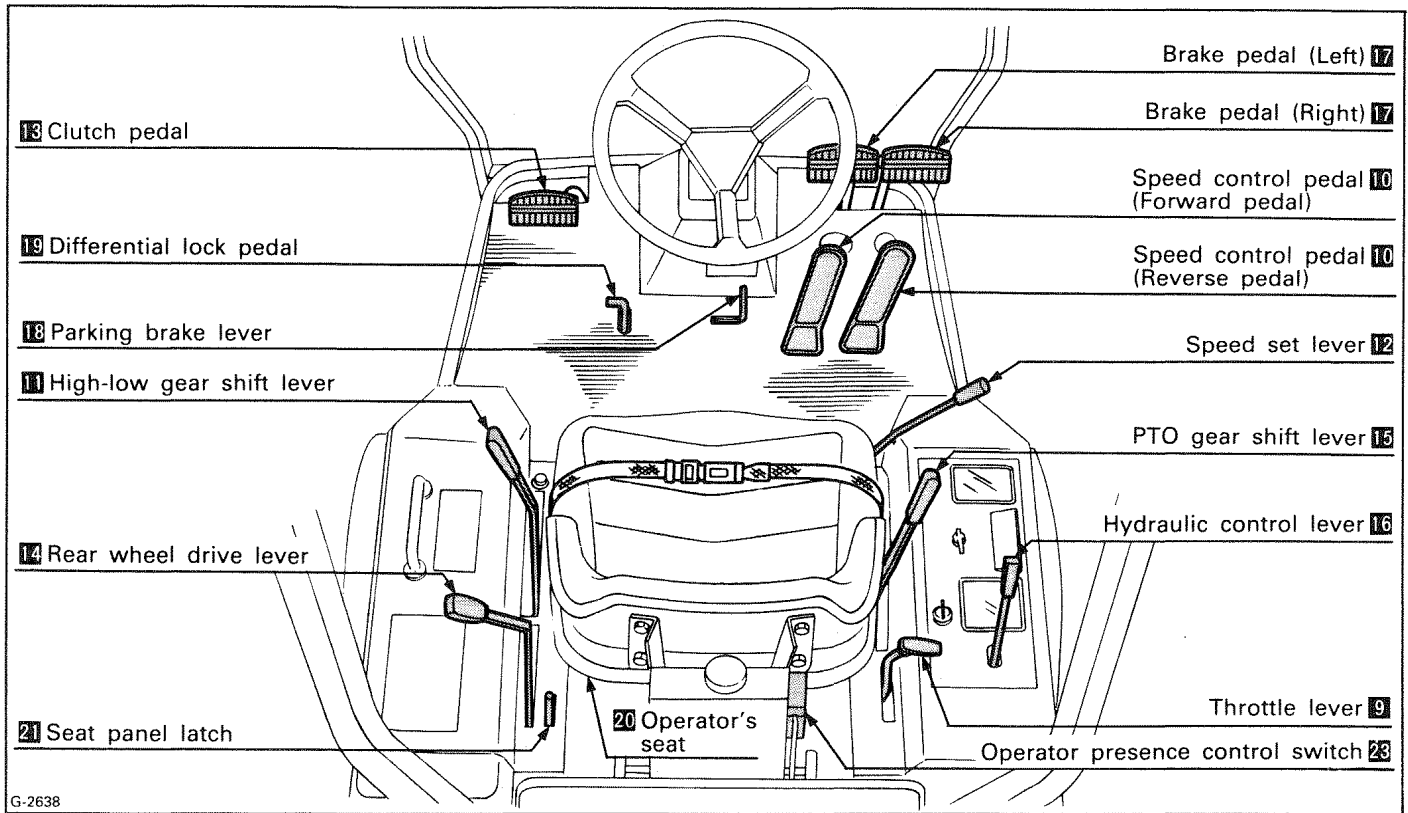

G-2638

9 Throttle Lever

Pulling the throttle lever rearward decreases engine speed, while pushing it forward increases engine speed.

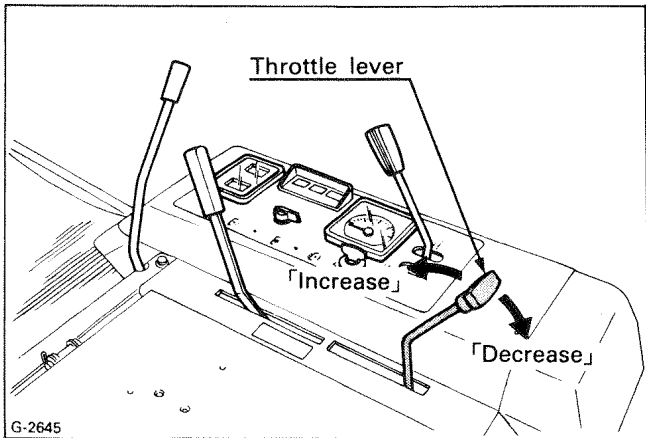

G-2645

10 Speed Control Pedal

● Forward Pedal

Depress the forward pedal (Left) with the toe of your right foot to move forward.

● Reverse Pedal

Depress the reverse pedal (Right) with the toe of your right foot to move backward. Speed Set Lever must be disengaged before depressing reverse pedal.

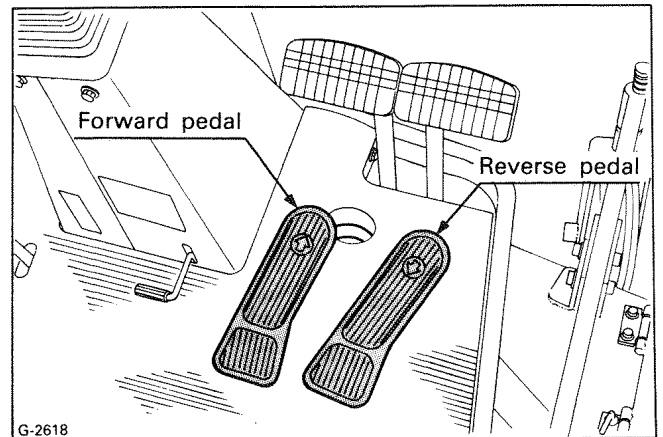

G-2618

11 High-Low Gear Shift Lever

High-low gear shift lever moves in the form of an "I" in 3 stages, "Low", "Neutral" and "High".

By using the speed control pedal and high-low gear shift lever, additional speeds can be obtained.

[IMPORTANT]

- To shift high-low gear shift lever, disengage the speed set lever and stop the front mower before attempting to proceed with speed change.

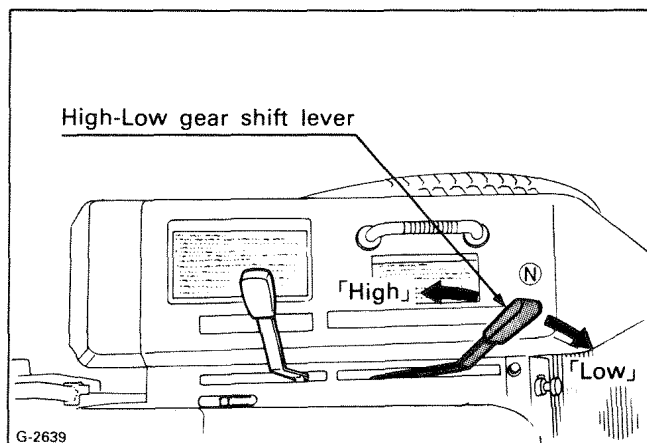

12 Speed Set Lever

CAUTION:



- Pull the speed set lever completely to the rear before starting the engine.

The Speed Set Lever is designed for efficiency and comfort when operating the front mower. This lever provides a constant forward operating speed by mechanically holding the speed control pedal at the selected position.

The Speed Set Lever can not be set at high speed range.

- To Engage Speed Set Lever:
 1. Accelerate speed to desired level using Speed Control Pedal, and move lever forward.
 2. Release Speed Control Pedal and desired speed will be maintained.
- To Disengage Speed Set Lever: move lever rearward.

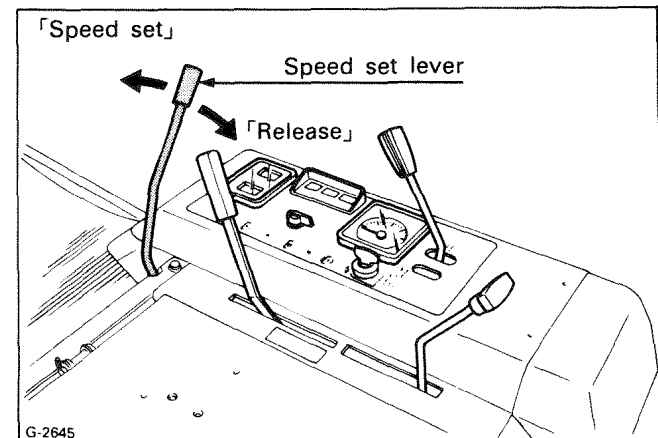

13 Clutch Pedal

The clutch is disengaged when the clutch pedal is fully pressed down.

[IMPORTANT]

- (1) The clutch pedal must be engaged slowly, but disengaged quickly or premature wear will result.
- (2) Never operate the front mower with your foot resting on the clutch pedal. This will also cause premature clutch wear.

14 Rear Wheel Drive Lever

Use the rear wheel drive when a greater traction is required. Move the lever rearward to engage the rear wheel drive.

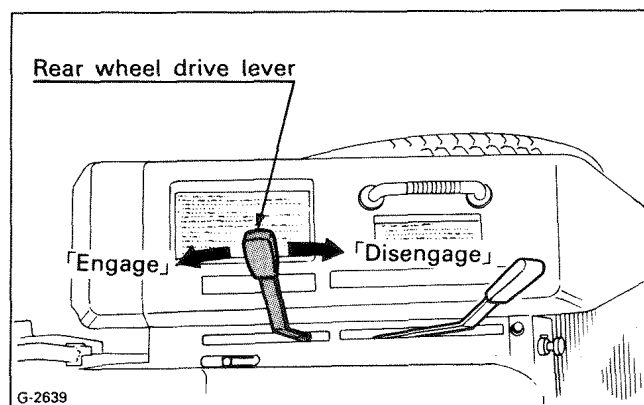

[IMPORTANT]

- (1) Depress the clutch pedal and stop the front mower before engaging the rear wheel drive lever.
- (2) If the rear wheel drive lever is difficult to disengage, turn the steering wheel in either direction, the lever will disengage easily.

15 PTO Gear Shift Lever

CAUTION:



- (1) Use only authorized attachments with the PTO speed specified for the individual attachment.
- (2) It is extremely dangerous to run an attachment at high speed (2500rpm) that is designed to be operated at the lower PTO speed (1100rpm).
- (3) The gear shift lever moves in the form of an "I" in 3 stages; "Low (1100rpm)"-forward, "Neutral"-center, "High (2500rpm)"-rearward.

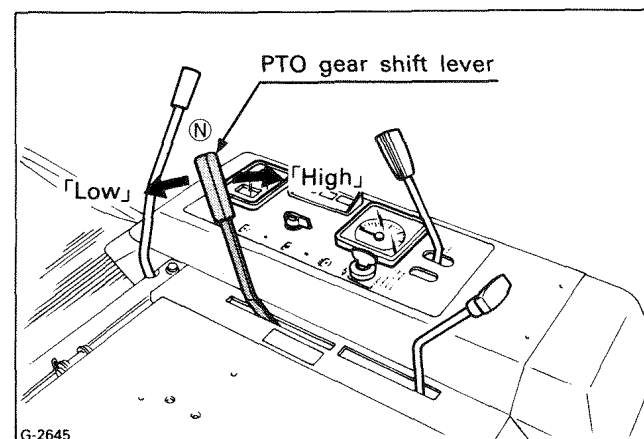

16 Hydraulic Control Lever (Lift Link)

To lower attachment, push the lever forward. To raise it, pull the lever backward. To float attachment, push the lever all way forward (detention). To release the hydraulic lever, pull it back.

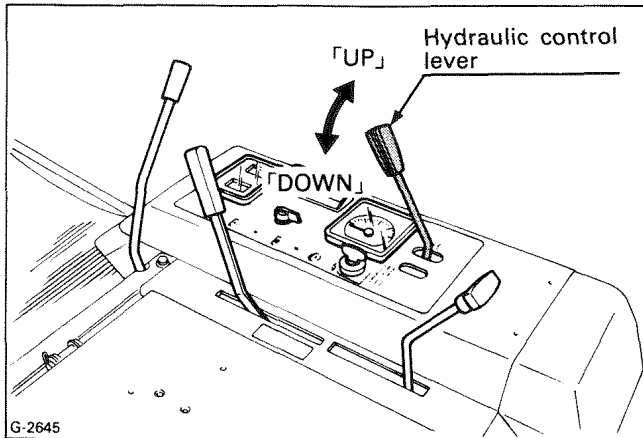

17 Brake Pedals (Right and Left)



WARNING:

- Applying only one front wheel brake at high speeds could cause the front mower to swerve or tipover.

- (1) Before operating the front mower, be sure to interlock the right and left pedals as illustrated below.
- (2) Use individual brakes to assist in making sharp turns at slow speeds (Field Operation Only). When making slow turns, disengage the brake pedal lock and depress only one brake pedal.

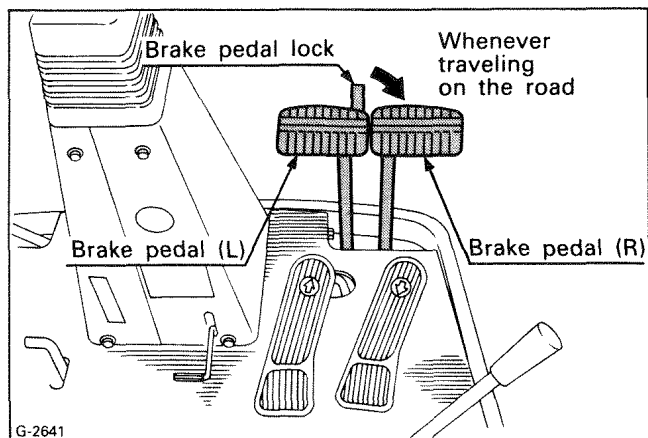

18 Parking Brake Lever

- (1) To apply the parking brake:
 - Lock the brake pedals together.
 - Depress the brake pedals.
 - Latch the brake pedals with the parking brake lever.
- (2) To release the parking brake: Depress the brake pedals again.

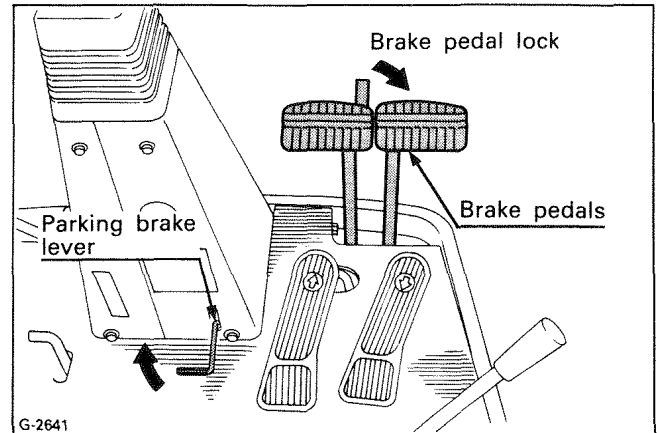

19 Differential Lock Pedal

If one of the front wheels should slip, step on the differential lock pedal. Both wheels will then turn together, reducing slippage.

The differential lock is applied only when the pedal is depressed.

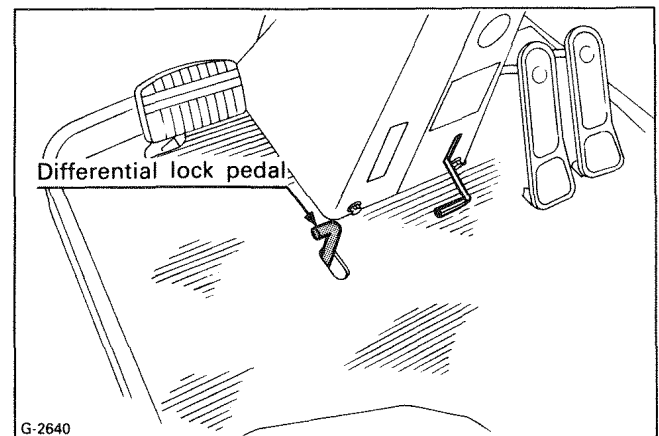

[IMPORTANT]

- If the differential lock will not release when the pedal is released, alternately step lightly on the brake pedals.



WARNING:

- It is dangerous to attempt to turn the front mower in either direction with the differential lock engaged. Release the lock before making such a turn.

20 Operator's Seat

The operator's seat position can be adjusted forward and backward by loosening the four knobs on the seat panel.

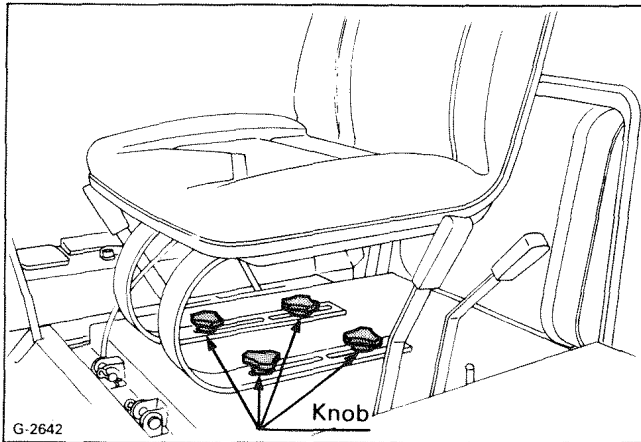

20 Operator's Seat (Deluxe type)

- (1) The operator's seat position can be adjusted forward and backward by pulling the seat adjusting lever to the right. Height adjustment is possible by loosening the height adjusting knob.

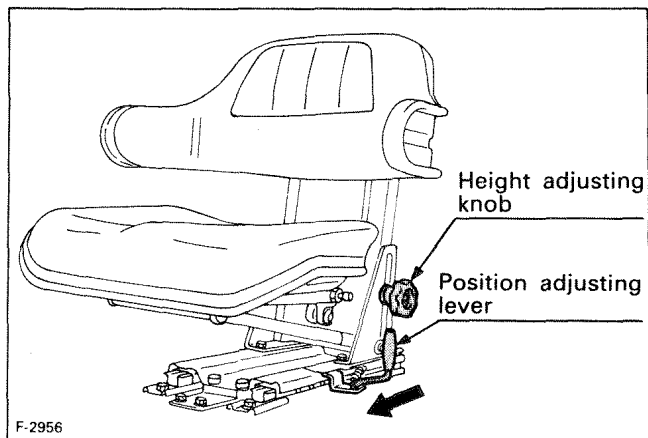

- (2) Turn the knob at the back of the seat to adjust seat cushioning tension. For standard cushioning tension, turn the knob until the two white arrow marks align with each other when operator is seated.

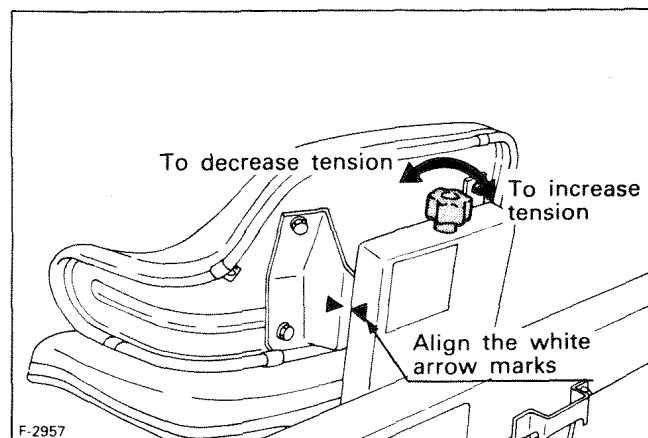

[IMPORTANT]

- After adjusting the operator's seat forward and backward, be sure to check that the seat is properly locked.

21 Seat Panel

To open the seat panel, push the latch on the left of the seat panel rearward, and lift the seat.

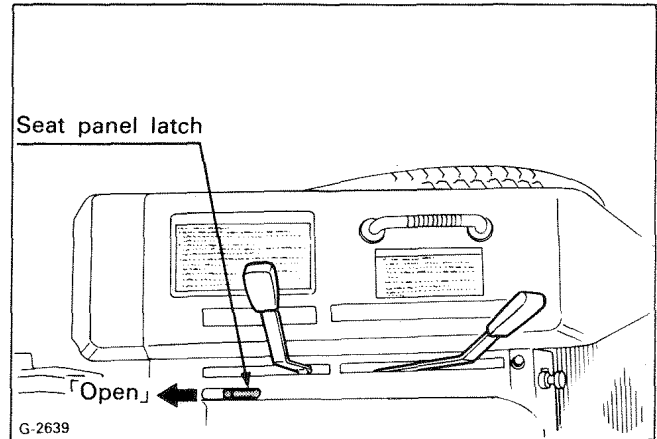

22 Hood

To open the hood, remove the latches located on both sides and lift the hood to the rear.

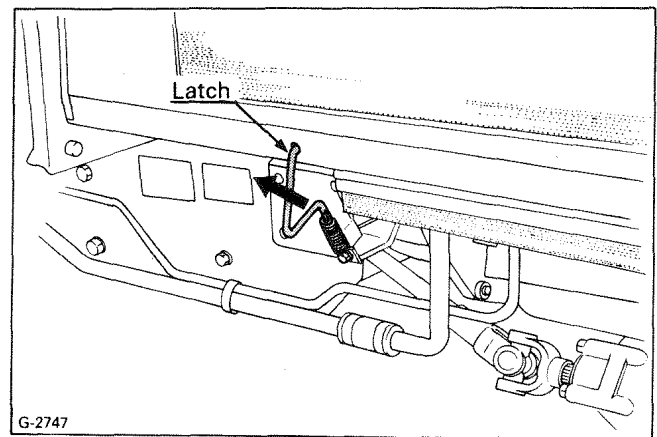

23 Operator Presence Control Switch

The operator seat is equipped with a operator presence control switch which automatically shuts off the engine if operator leaves the seat while PTO is engaged.

[IMPORTANT]

- If operator presence control switch is not working correctly repair at your Kubota dealer before operating the front mower.

5. LIFT LINK AND HYDRAULIC CONTROL

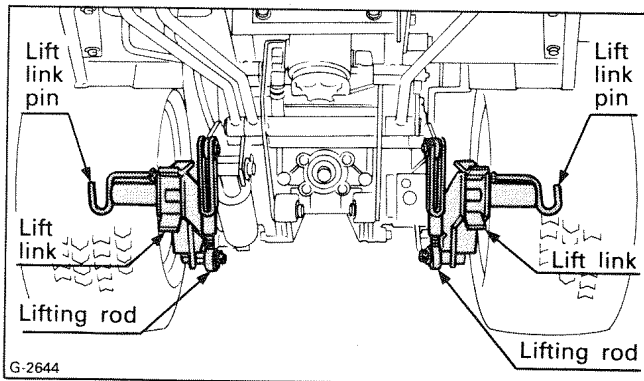

■ Lift Link

To install an attachment to the Lift Link.

- (1) Pull out the lift link pins and hold them with latches on both lift links.
- (2) Install the lift arms of attachment to the lift links and push the lift arms backward.
- (3) The spring loaded lift link pins are released automatically, so the lift arms and the lift link are connected together.

To remove an attachment from the Lift Link.

- (1) Pull out the lift link pins.
- (2) Pull out the lift arms of attachment from the lift links.

■ Lifting Rod

- (1) Level an attachment from side to side by turning the lifting rod to shorten or lengthen.
- (2) Adjust the lifting rod length so the lift link could be raised to the maximum height.

■ Implement Lowering Speed Control

- (1) Loosen the locknut of the set screw under the right fender.
- (2) Adjust down speed of implement by turning the set screw of the control valve. The lowering speed depends on weight of implement and operating speed. Adjust the set screw clockwise for faster lowering speed, counterclockwise for slower lowering speed.
- (3) Tighten the lock nut securely.

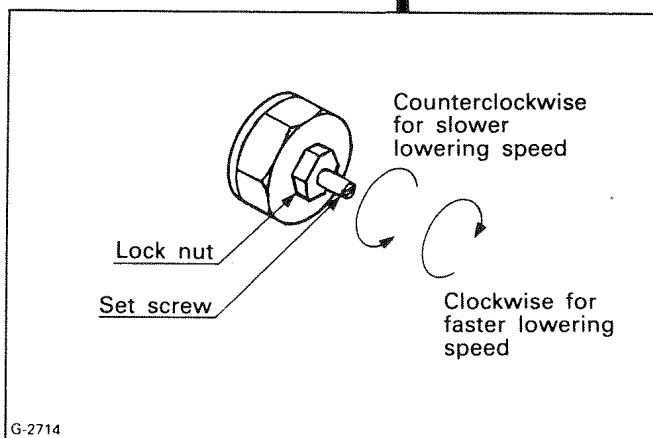
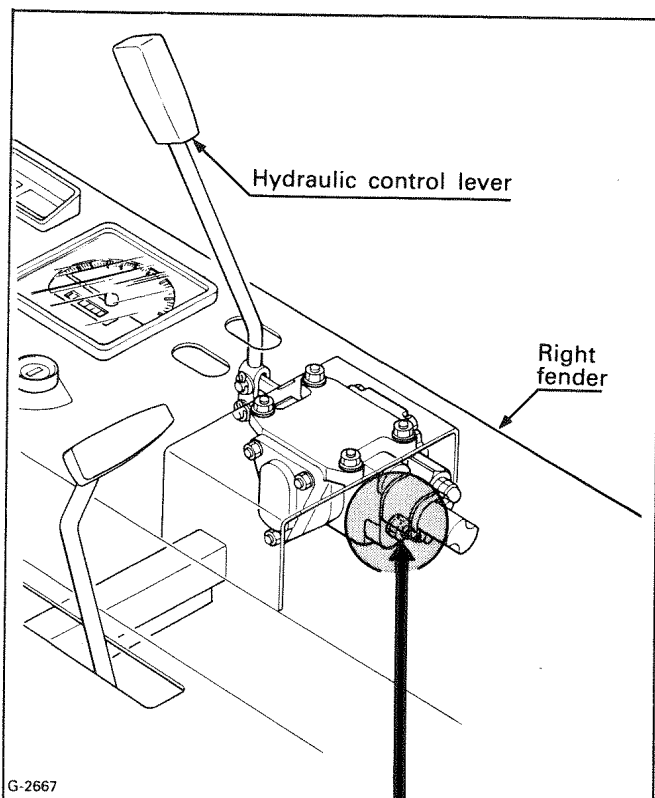

6. WHEELS, TIRES AND BALLAST

[IMPORTANT]

- Follow the same checking procedure when front mower is first used.

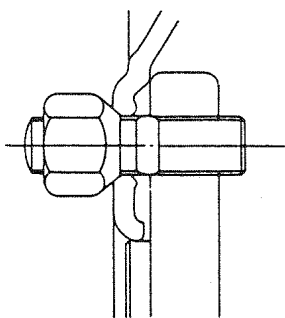
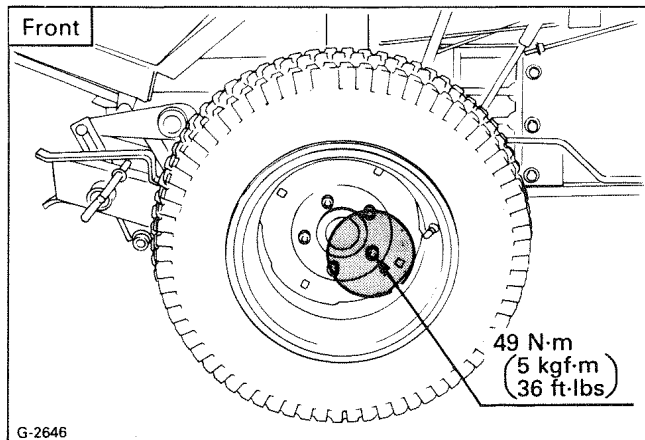

Wheels with beveled or tapered holes:
Use the tapered side of lug nut.

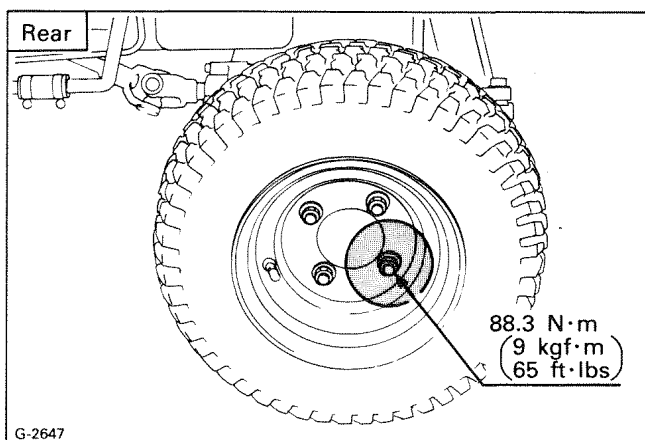

6.1 WHEEL ADJUSTMENT

■ Front Wheels (Drive Wheels)

Front tread width can be adjusted as shown with the standard equipped tires.

To change the front tread:

- (1) Jack up the front tires, and secure with stands.
- (2) Follow the illustrations below to get the desired tread width.

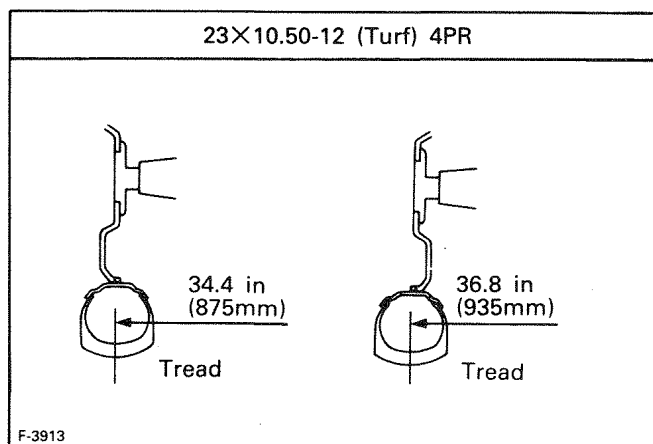

■ Rear Wheels (Steering Wheels)

Rear tread width is not adjustable.

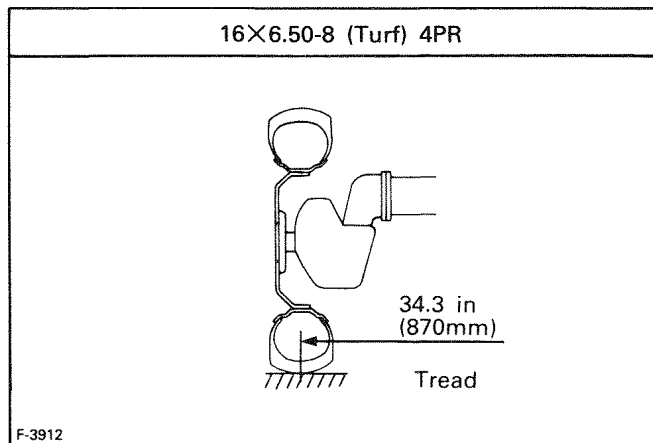

CAUTION:

Never operate front mower with a loose rim, wheel, or axle.

- (1) Whenever bolts are loosened, retighten to specified torque.
- (2) Check all bolts frequently and keep them tightened.

6.2 TIRES

The tire pressure is factory-set to the correct level, however, tire pressure will drop slowly in the course of time. Check tire pressure daily and inflate as necessary.

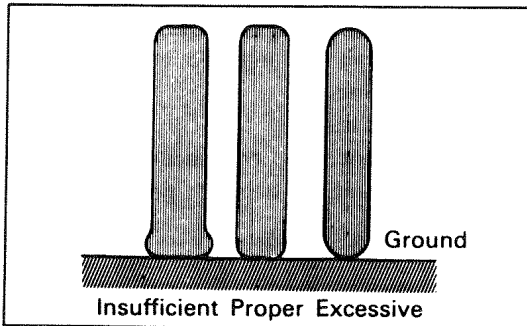

CAUTION:

- Do not attempt to mount a tire unless qualified. Use proper equipment.



WARNING:

- Never exceed the tire pressure shown below (maximum limit) when attempting to seat a bead. If beads have not been seated by the time the pressure reaches maximum limit, deflate the assembly, reposition the tire on the rim, relubricate, and reinflate. After seating the bead, adjust inflation pressure as recommended in the inflation pressure chart.

■ Inflation Pressure Chart

Rear	16×6.50—8, 4PR	200kPa (2.0kgf/cm ² ;28psi)
Front	23×10.50—12, 4PR	140kPa (1.4kgf/cm ² ;20psi)

6.3 BALLAST

■ Rear end Ballast

Add weight to rear end if needed for stability. Heavy front mounted attachments tend to lift rear wheels. Add enough ballast to maintain steering control and prevent tipover. The Attachment's Manual shows how much rear weight is required for your application. Rear weights are available from your Kubota Dealer.



CAUTION:

- Additional ballast will be needed for operating heavy attachments. When the attachment is raised, drive slowly over rough ground, regardless of how much ballast is used.

6.4 TOE-IN

Toe-in equals distances (A)(B)-(C)(D): or 0 to 0.3 in. (0 to 8mm).

To adjust toe-in loosen the lock nut and adjust the length of the tie rod until the proper toe-in measurement is obtained. Retighten the lock nut.

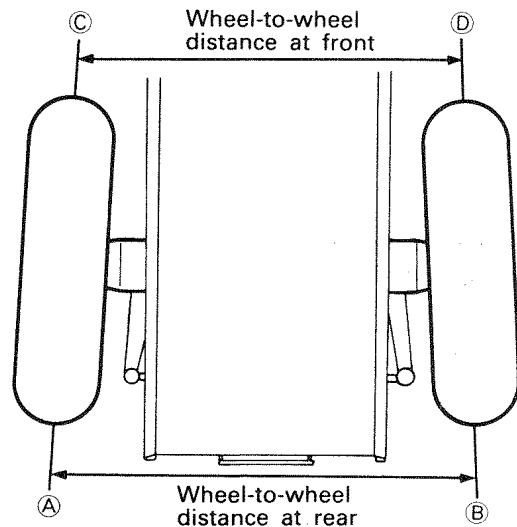

G-2648

7. OPERATION

■ Pre-Start Checks

Prior to starting the engine, do pre-start checks according to the Maintenance Check List. (See page 24)



CAUTION:

- (1) Read "Safe Operation" in the front of this manual.
- (2) Read all warning, caution, and danger labels located on the front mower.

7.1 OPERATING THE ENGINE



CAUTION:

- (1) To avoid the danger of exhaust fume poisoning, do not operate the engine in a closed building without proper ventilation.
- (2) Pull the speed set lever completely to the rear and to set high-low gear shift lever and PTO gear shift lever to the "neutral" position before starting the engine.

■ Starting

[IMPORTANT]

- When starting the engine after a lengthy storage (more than 3 months), pull the engine stop knob first, then engage the starter for about ten seconds to allow oil to lubricate all engine parts.
- (1) Sit in the operator's seat. If the front mower is equipped with a ROPS, fasten the seat belt.
 - (2) Apply the parking brake.
 - (3) Pull speed set lever completely to the rear and place high-low gear shift lever and PTO speed gear shift lever in the "neutral" position.
 - (4) Place the hydraulic control lever in the "down" position.
 - (5) Push in the engine stop knob.
 - (6) Insert the key into the key switch and turn one notch.
 - (7) Make sure that the engine oil pressure light is on.
 - (8) Depress the clutch pedal fully, turn the key switch right, and hold it for about 5 seconds. (at the preheat position)

For the appropriate preheating time, refer to the table below:

Temperature	Preheating Time
Over 0°C (32°F)	5 sec.
0 to -5°C (32 to 23°F)	10 sec.

- (9) Turn the key switch to the start position and the starter will turn and the engine will start.
- (10) Make sure that the engine oil pressure light has gone off. If the light is still on, stop the engine immediately and check the lubrication system.
- (11) Warm the engine by running it at a medium speed.

[IMPORTANT]

- (1) Do not turn the key switch to start position while the engine is running.
- (2) When the temperature is below 0°C (32°F), place the main gear shift lever in the neutral position and keep the engine at medium speed to warm the engine and transmission lubricant at least 10 minutes.
If the front mower is operated before the lubricant of engine and transmission is warm enough, the front mower life will be shortened.
- (3) Don't operate the front mower under full load conditions until it is sufficiently warmed up.
- (4) Do not use starting fluid.
- (5) When the ambient temperature is less than -15°C (5°F), remove the battery from the front mower and store it somewhere warm until needed.

■ Stopping the Engine

- (1) After idling the engine, turn the key switch to "OFF". The engine stops when the key is turned to "OFF". If the engine does not stop, pull the engine stop knob and hold it until the engine comes to complete stop.
- (2) Remove the key switch.

■ Warm-Up

Allow the engine to warm for 5 minutes without applying a load will allow oil to lubricate the engine parts. If a load is applied to the engine without this warm-up period, seizure or breakage may develop.

[IMPORTANT]

- When the accelerator lever is in the idling condition, idling rpm will decrease within 3 to 5 minutes after start of engine. This is normal and indicates that the operation of the solenoid, which increases the idling rpm, has stopped.



CAUTION:

- Be sure to apply the parking brake during engine warm-up.

■ Warming the Engine in Low Temperatures

Hydraulic oil serves as transmission oil and power steering fluid. Cold weather will cause increased fluid viscosity which may slow oil circulation or cause abnormally low hydraulic pressure after engine start-up. This can damage the hydraulic system and power steering. To prevent the above, warm the engine according to the table below:

Ambient temperature	Warm-up time requirement
Above 0°C (32°F)	At least 10 minutes
0 to -10°C (32 to 14°F)	10 to 20 minutes
-10 to -20°C (14 to -4°F)	20 to 30 minutes
Below -20°C (-4°F)	More than 30 minutes

[IMPORTANT]

- (1) Do not operate unless the engine is well warmed. If operation is attempted while the engine is still cold, the hydraulic mechanism will not function properly and its service life will be shortened.
- (2) If noises are heard after the hydraulic control lever has been activated and the implement is lifting, the hydraulic mechanism is not adjusted properly. Unless corrected, the unit will be damaged. Contact your Kobota dealer for adjustment.

■ Block Heater (If equipped)

A block heater is available, as an option, from your dealer. It will assist you when starting your front mower if the ambient temperature is below 0°C (32°F).

7.2 OPERATING THE FRONT MOWER

■ Starting

- (1) Check to see that the right and left brake pedals are properly connected.
- (2) Raise the attachment.

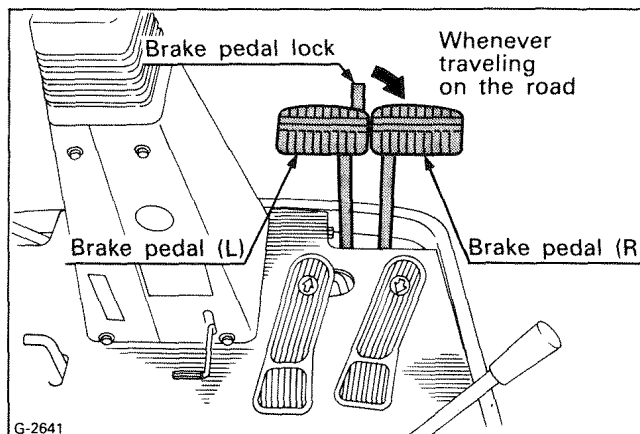

- (3) Depress the clutch pedal, and shift the high-low gear shift lever to the desired speed and slowly release the clutch.
- (4) Accelerate the engine to a proper level to prevent engine stall.
- (5) Unlock the parking brake.
- (6) Depress the forward pedal (left) with the toe of your right foot to move forward.
Depress the reverse pedal (right) with the toe of your right foot to move backward.

[IMPORTANT]

- (1) Be sure to release the parking brake before moving the front mower.
- (2) Change transmission speed only after depressing the clutch pedal completely.
- (3) Avoid slipping the clutch to prolong the service life of clutch, paying attention to the following points:
 - Do not slip the clutch when changing speed.
 - Select proper gear and engine speeds depending on the type of job.
 - Do not operate the front mower with your foot resting on the clutch pedal.

**CAUTION:**

- (1) Sudden release of the clutch may cause the front mower to lunge unexpectedly.
- (2) To help assure straight line stops when driving at transport speeds, lock the brake pedals together. Uneven braking at road speeds could cause the front mower to tipover.
- (3) Do not allow any person other than the driver to ride on the front mower.
- (4) Do not drive the front mower close to the edges of ditches or banks which may collapse under the weight of the front mower, especially when the ground is loose or wet.
- (5) Operate the front mower up and down slopes, not across. Avoid sudden starts and stops on slopes. Extra caution is required when changing directions on a slope, always slow down.
- (6) When descending a slope, never disengage the clutch or shift levers to neutral. This will cause a loss of front mower control.
- (7) Installation of a Roll-Over Protective Structure (ROPS) with a seat belt is recommended by Kubota in most applications. Refer to the Safety Section.
- (8) Do not apply the differential lock while traveling at road speeds. Doing so could cause the front mower to swerve out of control.

■ Stopping

- (1) Slow the engine down.
- (2) Step on the clutch and brake pedal.
- (3) After the front mower has stopped, shift the transmission to neutral, release the clutch pedal, and pull the parking brake lever to apply the parking brake.
- (4) Lower the attachment.

**CAUTION:**

- Always apply the parking brake, shut the engine off and remove the key before dismounting.

■ Parking

- (1) When parking, be sure to apply the parking brake.
- (2) If it is necessary to park on an incline, be sure to chock the wheels to prevent accidental rolling of the machine.

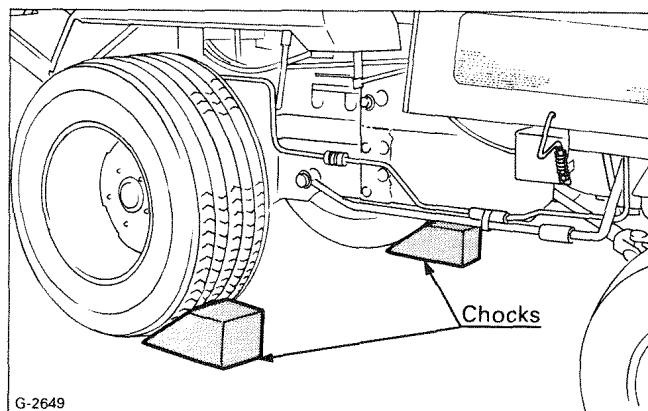

- (3) Before getting off the front mower, stop the engine, remove the key and lower the attachment to the ground.

■ Power Steering

- (1) Power steering is activated only while the engine is running. Slow engine speeds will make the steering wheel a little difficult to handle. While the engine is stopped, the front mower will function in the same manner as manual steering machines.
- (2) When the steering wheel is turned all the way to the stop, the relief valve is activated. Do not hold the steering wheel in this position for long periods.
- (3) Avoid turning the steering wheel while the front mower is stopped, and/or operating at slow engine speeds, or excessive wear on the tires and rims will occur.
- (4) The power steering mechanism makes the steering wheel very easy to handle. Be careful when driving at high speeds.

■ Differential Lock

Though useful when operated properly, the differential lock can be very dangerous if misused, and may result in damage to the machine. Use the differential lock only in the following cases:

- (1) If one wheel is caught in mud and the front mower cannot go forward.
- (2) If the wheels slip in slippery places.



CAUTION:

- (1) **When using the differential lock, always slow the engine down.**
- (2) **The differential lock automatically releases when the pedal is released. If this does not happen, lightly step on the brake pedals alternately, or turn the steering wheel slightly.**
- (3) **Always disengage the differential lock before turning the front mower.**
- (4) **Do not engage differential lock while one wheel is spinning and the other is completely stopped. This may cause the front mower to lunge unexpectedly.**

7.3 CHECK DURING DRIVING

While driving, check the following to ensure that all the parts are functioning correctly.

■ Coolant



CAUTION:

- **Do not remove radiator filler cap until coolant temperature is well below its boiling point. Then rotate cap slightly to the stop to relieve any excess pressure before removing cap completely.**

If the temperature of the coolant rises above 100°C (212°F), stop the engine immediately, and determine the cause. Check the following;

- (1) Shortage or leakage of the coolant.
- (2) Foreign matter on the radiator net or dust and dirt between the radiator fins.
- (3) Loose fan drive belt.
- (4) Blockage in the radiator tube.

■ Engine Oil Pressure Light

The pressure light signals to the operator that the engine oil pressure is low. If the light should illuminate during operation, stop the engine immediately and check:

- (1) The level of the engine oil. (See page 26)
- (2) The conditions of the lubricating system.

■ Battery Charge Light

The charge light signals to the operator that alternator is not charging the battery.

If the light illuminates during operation, immediately stop the engine and check for:

- (1) Wiring failure.
- (2) Connection failure of alternator and regulator.
- (3) Alternator drive belt failure.

■ Fuel

Do not allow the fuel tank to empty completely.

Doing so will allow air to enter into the fuel system. If this happens, the fuel system must be bled. (See page 25)

■ Exhaust Fumes

- (1) Exhaust fumes are colorless, odorless and deadly gases.
- (2) If the exhaust turns dark often while driving, this probably indicates an overload on the engine. This will result in excessive wear to the engine, drivetrain, and tires. Operate in a lower gear or decrease the load placed on front mower.

■ Immediately Stop the Engine if:

- (1) The engine suddenly slows down or accelerates.
- (2) Unusual noises suddenly develop.
- (3) Exhaust suddenly becomes very dark.
- (4) The oil pressure warning light goes on during operation.

[NOTE]

- For checking and servicing of your front mower, contact your nearest Kubota dealer for instructions.

8. MAINTENANCE

8.1 DAILY CHECK

To prevent trouble from occurring, it is important to perform the following checks before starting.



CAUTION:

- Be sure to check and service the front mower on a flat area with the engine shut off, the parking brake set and the key removed.

- (1) Check areas where previous trouble was experienced.
- (2) While walking around the front mower:
 - 1) Check the tire pressure, and check for wear and damage. (See page 18)
 - 2) Check for oil and water leaks.
 - 3) Check the engine oil level.
(See page 26)
 - 4) Check the amount of transmission fluid.
(See page 27)
 - 5) Check fuel level. (See page 25)

- 6) Check coolant level. (See page 30)
- 7) Check for dust in the air cleaner dust cup.
(See page 32)
- 8) Check the front mower body for damage and check the torque of all bolts and nuts.
- (3) While sitting in the operator's seat:
 - 1) Check the speed control pedal, brake pedals and clutch pedal. (See page 35)
 - 2) Check the parking brake.
 - 3) Check the steering wheel.
- (4) Turning the key switch on:
 - 1) Check the performance of the warning.
 - 2) Check headlights, clean if necessary.
- (5) Starting the engine:
 - 1) Check the color of the exhaust fumes.

8.2 LUBRICANTS

To prevent serious damage to hydraulic systems, use only genuine KUBOTA fluid or its equivalent.

Place	Capacity	Lubricants
Engine crankcase	3.3 U.S.qts. (3.1 ℓ)	<ul style="list-style-type: none"> ● Engine oil: API Service CC or CD Below 0° (32°F) SAE10W or 10W-30 0 to 25°C (32 to 77°F) SAE20 or 10W-30 Above 25°C (77°F) SAE30 or 10W-30
Transmission	13.4 U.S.qts. (12.7 ℓ)	(See page 40)
Rear axle differential case	1.6 U.S.qts. (1.5 ℓ)	<ul style="list-style-type: none"> ● Gear oil SAE80 or SAE90
Rear axle gear case (R & L)	0.5 U.S.qts. (0.5 ℓ)	<ul style="list-style-type: none"> ● Gear oil SAE80 or SAE90
Brake pedal shaft Lift link arm shaft Clutch release hub Seat adjuster (Deluxe Seat)	Moderate amount	<ul style="list-style-type: none"> ● SAE multi-purpose type grease

8.3 MAINTENANCE CHECK LIST

Frequency of Checks	Check Points	Reference Pages
Initial operation (initial 60 hours)	During this period, pay special attention to the following. (1) After the initial 35 hours of use, change the engine oil. (2) After the initial 50 hours of use, change the transmission fluid and oil filter cartridge and clean the transmission strainer. (3) Quick starts or sudden braking should be avoided.	27 to 28
Every 75 hours	Change engine oil.	27
Every 100 hours	Lubricate the following points. Brake pedal shaft, Lift link arm shaft, Clutch release hub.	29
	Check the following points to be connected securely. Hydraulic inlet pipe clamps, Fuel line clamps.	25
	Clean air cleaner element.	32
	Clean fuel filter.	26
	Check battery electrolyte level.	32 to 33
	Check fuel line.	25
	Check fan drive belt tension.	35
	Check clutch play.	35
	Check brake play.	35
	Check steering wheel play.	—
Every 150 hours	Change engine oil filter cartridge.	27
	Check radiator hose.	30
Every 200 hours	Change transmission oil filter cartridges.	28
Every 300 hours	Change transmission fluid. Transmission case, rear axle differential case, front axle gear case (right and left). ● Clean transmission strainer.	27 to 29
Every 400 hours	Change fuel filter.	26
Every 500 hours	Flush radiator.	30 to 31
Every one to two months	Recharge battery if necessary.	32 to 33
Every 3 months	Change scale inhibitor and coolant.	30
Every year or every 6 times of cleaning	Change air cleaner element.	32
Every year	Change anti-freeze and coolant.	30 to 31
Every 2 years	Change battery, if necessary.	—
	Change radiator hose and clamps, if necessary.	30
	Change fuel line and clamps, if necessary.	25
	Change hydraulic hoses and clamps, if necessary.	—

9. CHECK AND MAINTENANCE

9.1 FUEL

■ Checking and Refueling



WARNING:

- Stop the engine before adding fuel. Keep all sparks and flames away.

- (1) Check the fuel level. The fuel level should not fall below the lower limit.

Fuel tank capacity	9.0 U.S.gals. (34 liters)
--------------------	---------------------------

- (2) Use diesel fuel No.2-D.
- (3) Use No.1 diesel fuel, if temperature is below -10°C (15°F).

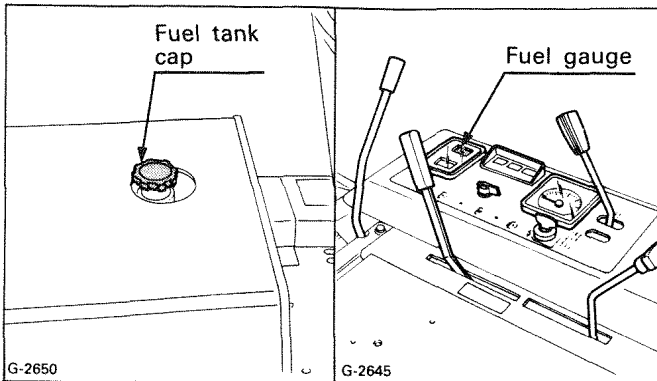

[IMPORTANT]

- (1) Always use a strainer when refueling to prevent dirt from entering fuel system.
- (2) If the fuel tank empties completely, air is admitted to the fuel system. It then becomes necessary to bleed the fuel system before the engine will start.

■ Fuel Line Bleeding

Air must be removed:

- (1) When the fuel filter or lines are removed.
- (2) When the tank becomes completely empty.
- (3) After the front mower has not been used for long periods.

Use the following procedure for bleeding the fuel system:



CAUTION:

- Do not bleed the fuel system when the engine is hot.

- (1) Fill up fuel tank with fuel.
- (2) Open the fuel cock.

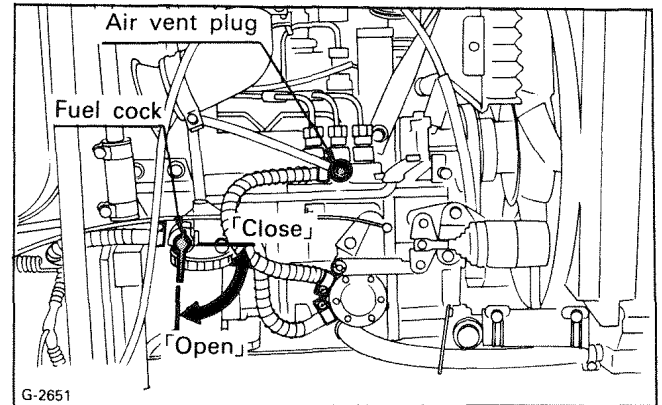

- (3) Open the air vent plug.
- (4) Start the engine and operate it for approx.1 minute and then stop the engine.
- (5) Close the air vent plug.



CAUTION:

- Be sure to close the air vent plug on the fuel injection pump and the fuel filter cock except when air is vented, or premature starting may take place.

■ Checking Fuel Line



CAUTION:

- (1) Stop the engine when attempting to check or change as prescribed below.
- (2) Check the fuel line periodically.
An old or worn line may leak fuel on the engine, and cause a fire.

Check the fuel line connections every 100 service hours or every 6 months, whichever occurs first.

- (1) If the clamp is loose, apply a slight coat of lubricant onto the threads and retighten securely.

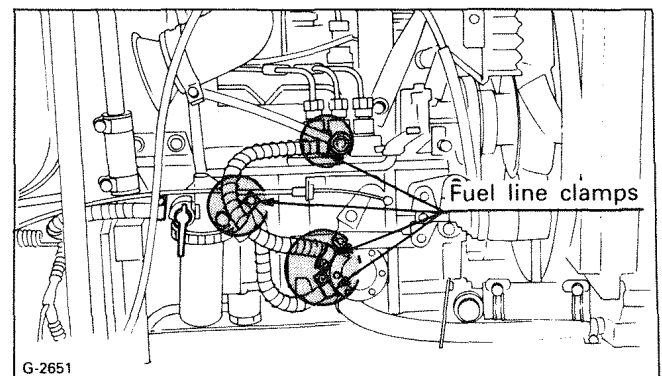

- (2) The fuel line is made of rubber and will age. Change the fuel line together with the clamp whenever worn and tighten securely.
- (3) After the fuel line and clamp have been changed, bleed the fuel system.

[IMPORTANT]

- (1) When the fuel line is disconnected, close both ends of the fuel line with a piece of clean cloth to prevent dust and dirt from entering the fuel system.
- (2) Extra care must be taken to prevent dust and dirt from entering the fuel pump.

■ Cleaning the Fuel Filter Bowl

When operation reaches approximately 100 hours, clean the fuel filter.

This should not be done in the field, but in a clean place in order to prevent dust from entering the fuel system.

- (1) Open the hood. (See page 14)
- (2) Close the fuel cock.

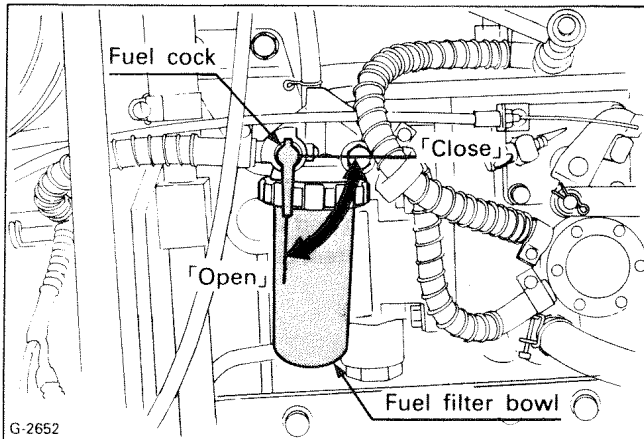

- (3) Unscrew and remove the screw ring, and rinse the inside with kerosene.
- (4) Take out the element and dip in the kerosene to rinse.

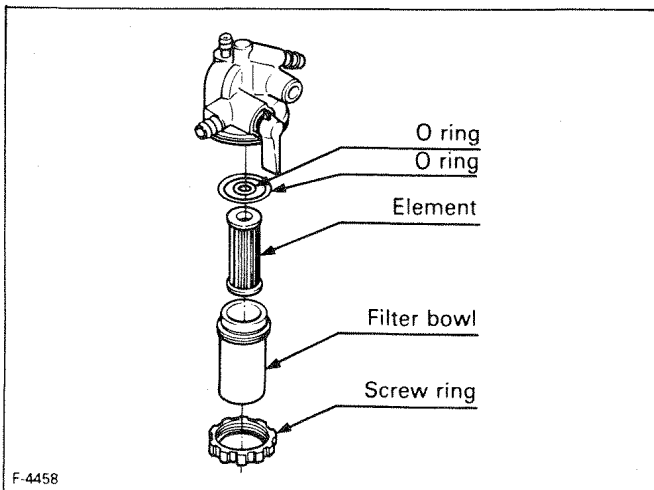

- (5) After cleaning, reassemble the fuel filter, being careful to keep dust and dirt out of filter.
- (6) Bleed the injection pump.

[IMPORTANT]

- If dust and dirt enter the fuel, the fuel pump and injection nozzles are subject to quick wear. To prevent this, be sure to clean the fuel filter bowl periodically.

9.2 ENGINE OIL

■ Oil Level Check and Refilling

(See page 23,40)

- (1) Check engine oil before starting the engine or 5 minutes after the engine has stopped.
- (2) To check the oil level, remove the dipstick, wipe it clean, replace it, and remove again. Check to see if the oil level is between the two notches.
- (3) If the level is below the lower notch, add new oil to the recommended level.

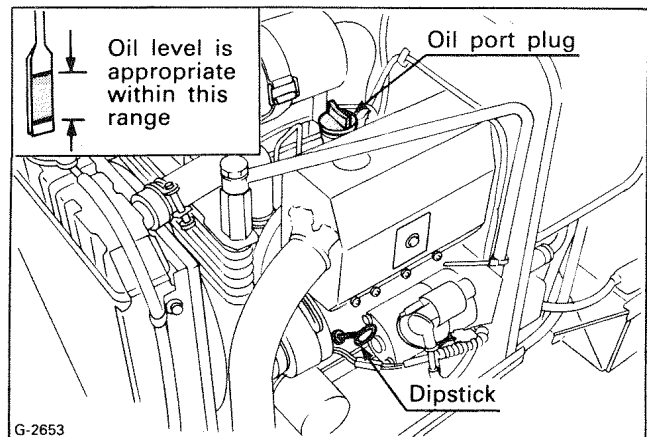

- (4) When using an oil of different manufacturer or viscosity from the previous one, remove all of the old oil. Never mix two different types of oil.
- (5) Use the proper SAE Engine Oil according to the air temperature.
Refer to 8.2 "LUBRICANTS"

■ Engine Oil Change



CAUTION:

- Before changing the oil, be sure to stop the engine.

- (1) To change the used oil, remove the drain plug at the bottom of the engine and drain the oil completely. All the used oil can be drained out easily while the engine is still warm.

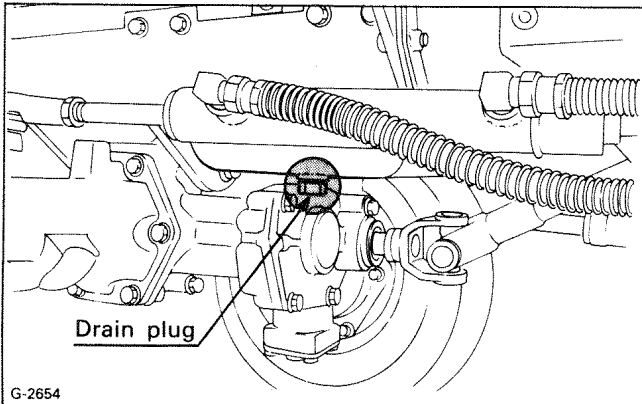

- (2) Reinstall the drain plug.
- (3) Fill new oil up to the upper notch on the dipstick.

■ Engine Oil Filter Cartridge Change



CAUTION:

- Be sure to stop the engine before changing the oil filter cartridge.

- (1) The oil filter cartridge must be changed every 150 service hours.
- (2) To prevent the oil leakage to the side cover (panching metal) put the oil pan or a rag under the oil filter cartridge before changing it.
- (3) Apply a light coat of oil onto the cartridge gasket.
- (4) To install the new cartridge, screw it in by hand. Overtightening may cause deformation of rubber gasket.
- (5) After the new cartridge has been replaced, the engine oil normally decreases a little. Check for leaks, and refill if necessary.

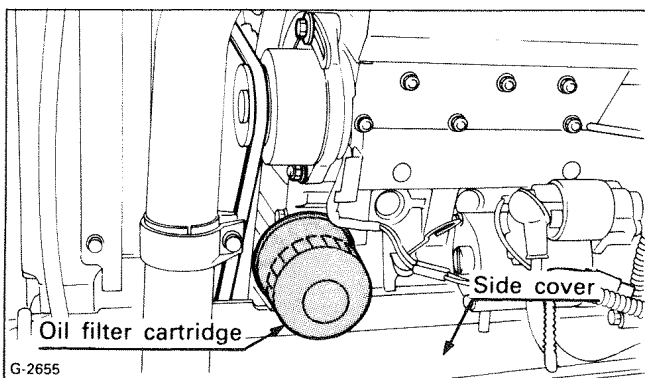

[IMPORTANT]

- To prevent serious damage to the engine, the replacement element must be of high quality. Use only a genuine KUBOTA filter.

9.3 TRANSMISSION FLUID



CAUTION:

- Be sure to stop the engine before checking and changing the transmission fluid.

■ Transmission Fluid Check and Replenishment

To check the oil level, remove the dipstick, wipe it clean, replace it, and remove it again. Check to see that the oil level is between the two notches.

If low, replenish through the port.

Use multi-grade transmission fluid. (See page 40)

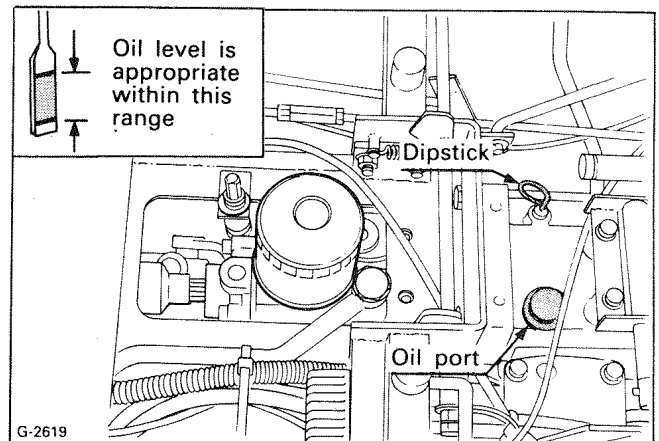

■ Transmission Fluid Change

The fluid in the transmission case is also used for the hydraulic system.

To drain the transmission case, place oil pan underneath the transmission case and remove the drain plug at the bottom of the transmission case.

After draining, disassemble and clean the transmission strainer. After reassembling, fill with new multi-grade transmission fluid.

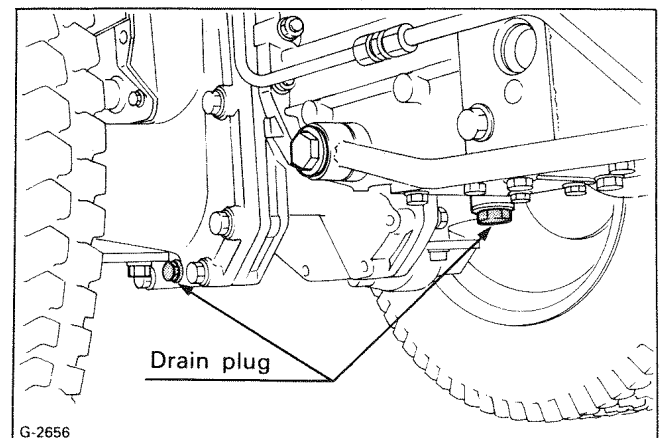

[IMPORTANT]

- Never operate the front mower immediately after changing the transmission fluid and cleaning the transmission strainer. Keep the engine at medium speed for a few minutes to prevent the damage to the transmission.

■ Transmission Oil Filter Cartridge Change (HST filter cartridge, Return filter cartridge)

**CAUTION:**

- Be sure to stop the engine before changing the oil filters.

- (1) The oil filter cartridge must be changed every 200 service hours.
- (2) Open the seat panel.
- (3) Remove the oil filter cartridge by using a filter wrench.
- (4) Tighten the screw (A) lightly, using a screwdriver (HST filter only).
- (5) Apply a light coat of oil onto the cartridge gasket.
- (6) To install the new cartridge, screw in by hand. Overtightening may cause deformation of rubber gasket.
- (7) After the new cartridge has been replaced, the transmission fluid level will normally decrease slightly. Make sure that the transmission fluid does not leak through the seal. Recheck the fluid level.

[IMPORTANT]

- (1) To prevent serious damage to the hydraulic system, the replacement filter must be a highly efficient, 10 micrometer filter. Use only a genuine KUBOTA filter or its equivalent.
- (2) When using the auxiliary hydraulics, replace the transmission oil filter cartridge after initial 50 service hours.

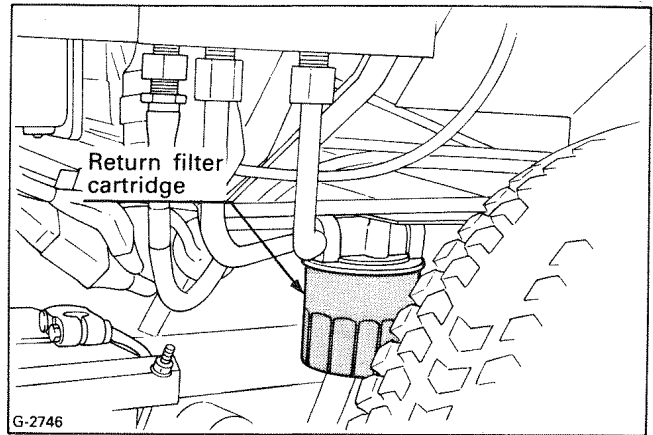
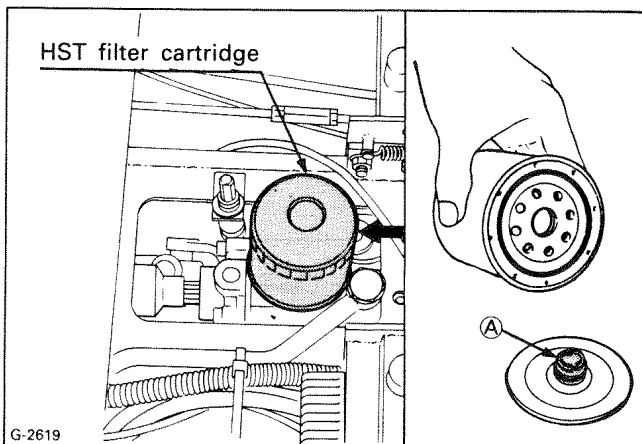

■ Cleaning Transmission Strainers

Since fine fillings in the oil could impair the component parts of the hydraulic system that are precision built to withstand high pressure, the suction line has an oil strainer. When changing the transmission fluid, disassemble and rinse the strainer with kerosene to completely clean off fillings. When reassembling, be careful not to damage the parts.

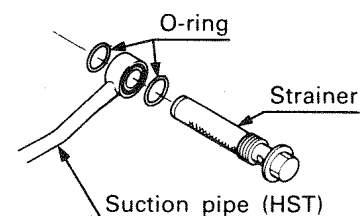
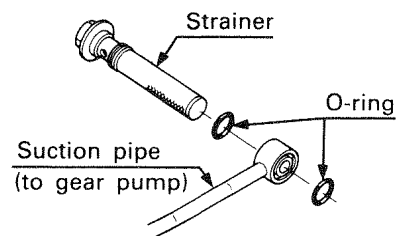
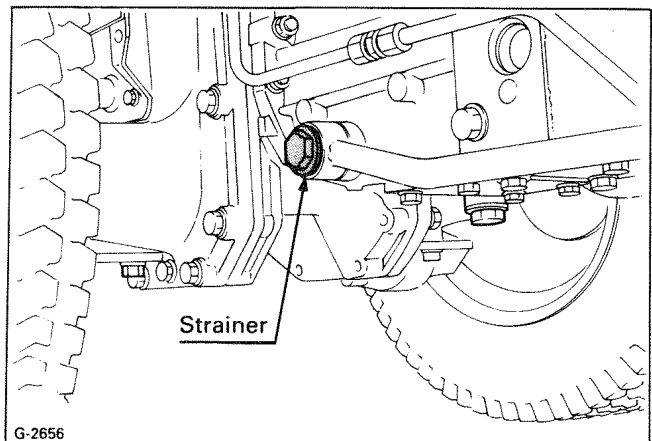

G-2773

9.4 CHANGING REAR AXLE DIFFERENTIAL CASE OIL (See page 40)

Remove the drain and filling port plug. After draining, replace the drain plug and fill with new oil.

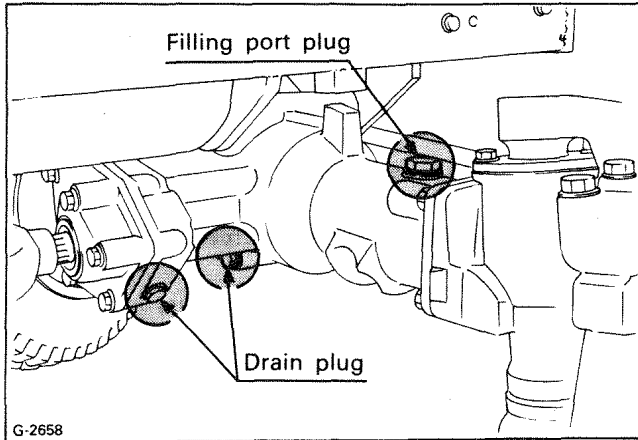

9.5 CHANGING REAR AXLE GEAR CASE OIL (RIGHT AND LEFT)(See page 40)

Remove the drain and filling port plugs with hex head wrench to drain the used oil. After draining, replace the drain plug and fill with new oil.

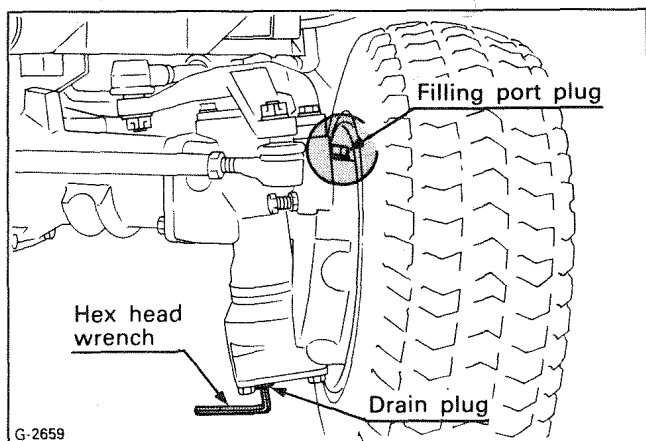

9.6 OILING AND GREASING POINTS BEFORE STARTING

Oil or grease the following points before starting.

■ **Brake Pedal Shaft · Lift Link Arm Shaft**
Grease brake pedal shaft, and the lift link arm shaft.

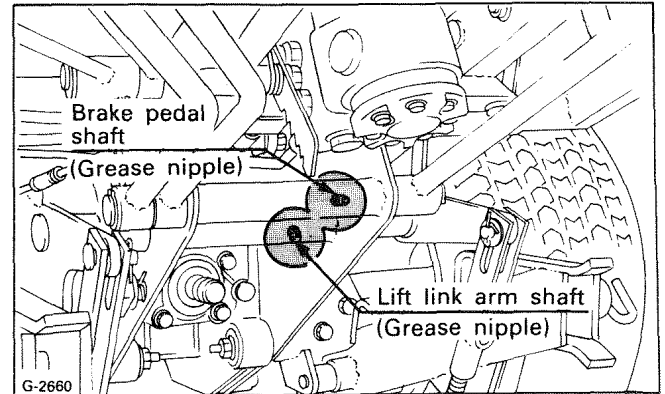

■ **Clutch Release Hub**

Lubricate the clutch release hub (throwout bearing) sparingly. Too much grease will adversely effect the clutch performance.

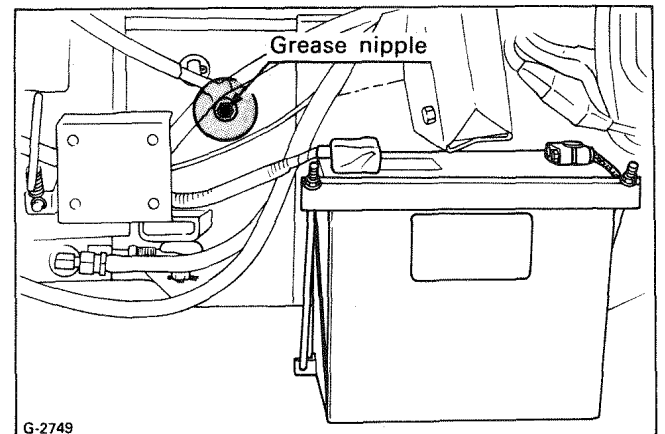

■ **Seat Adjuster (Deluxe type)**

Apply the grease on the surface of the sliding guide.

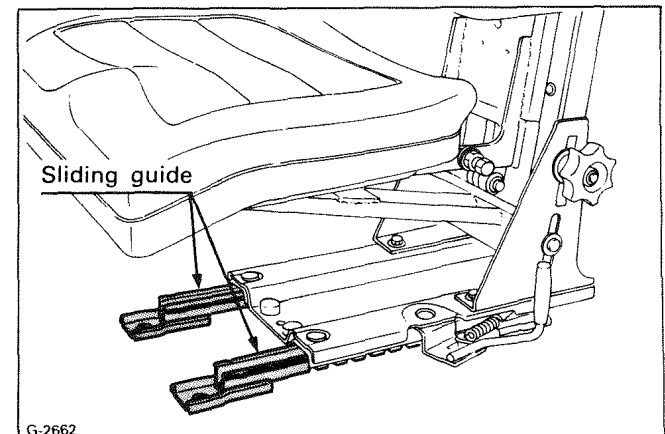

9.7 RADIATOR



CAUTION:

- Do not remove radiator filler cap until coolant temperature is well below its boiling point. Then rotate cap slightly to the stop to relieve any excess pressure before removing cap completely.

■ Checking, Replenishing and Changing Coolant

- (1) Remove the radiator pressure cap and check to see that the coolant level is just below the fill port. If low, add clean water and anti-freeze.

Coolant capacity	3.9 U.S.qts. (3.7 liters)
------------------	---------------------------

[IMPORTANT]

- (1) Use clean, fresh water and anti-freeze to fill the radiator.
- (2) Tighten the radiator cap securely.

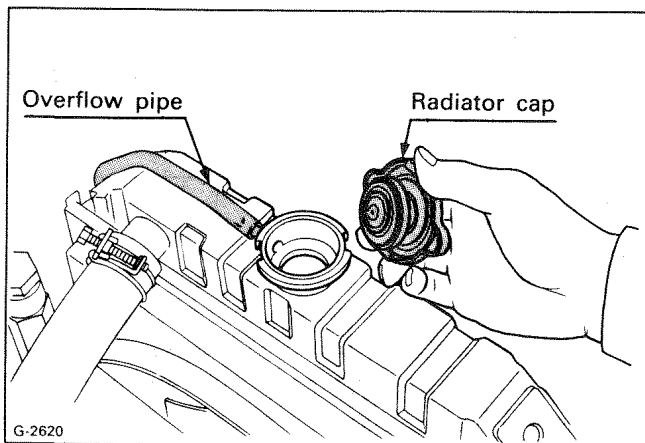

- (3) To drain the used coolant, open the radiator drain cock and remove radiator cap.

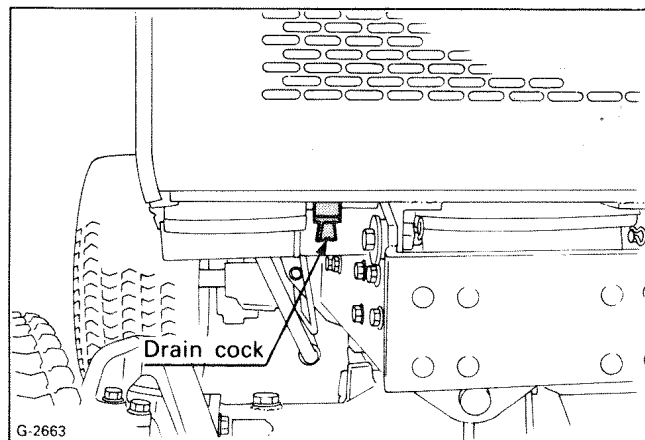

- (4) Be sure to close the radiator cap securely. If the cap loose or improperly closed, water may leak out and the engine could overheat.

- (5) Radiator should be filled with 50/50 solution of anti-freeze and water at all times or as recommended by the anti-freeze manufacturer. The anti-freeze contains a corrosion inhibitor and will allow a higher operating temperature in the radiator.
- (6) Do not use an anti-freeze and scale inhibitor at the same time.

■ Checking Radiator Hose

Checking radiator hose clamp tightness is recommended at every 150 service hours or every 6 months, whichever occurs first.

- (1) If the clamp is loose, apply a small amount of oil and retighten securely.
- (2) The radiator hose is made of rubber and tends to deteriorate with age. Check hoses and clamps every 150 hours and replace if damaged or aged.

■ Kubota Scale Inhibitor No.11

- (1) The Kubota Scale Inhibitor No.11 or its equivalent prevents scale formation in the coolant for three months. Scale build-up sharply reduces cooling efficiency and can occur in either hard or soft water.
- (2) The coolant should be completely changed every three months when using a scale inhibitor.

■ Water Leakage Remedy

- (1) A small water leak can be eliminated with the Kubota Radiator Cement No.40 or equivalent.
- (2) If water leakage should become excessive, consult your local dealer.

■ Cooling System Cleaning

- (1) The water cooling system should be cleaned on the following occasions:
 - Every 500 service hours
 - When adding an anti-freeze solution.
 - When changing from water containing anti-freeze to pure water.
- (2) When cleaning the water cooling system, Kubota Scale Inhibitor No.20, or its equivalent, is recommended to remove scale build-up.

■ Anti-Freeze

If the cooling water freezes, the engine cylinder and radiator may crack. In cold weather, before the temperature drops below 0°C (32°F), add a proper amount of anti-freeze to the front mower coolant system.

- (1) There are two types of anti-freeze solutions, permanent type (PT), and semi-permanent type (SPT). Kubota recommends using the permanent type.
- (2) When anti-freeze is used for the first time, drain and flush the cooling system completely.
- (3) The radiator should be filled with 50 percent solution of anti-freeze and water as recommended by the anti-freeze manufacturer. Most anti-freeze contains a corrosion inhibitor and allow a higher operating temperature in the radiator.
- (4) Mix the anti-freeze and the water first, then pour the solution into the radiator.
- (5) When the coolant mixed with anti-freeze decreases due to evaporation, replenish with water only. If leaking is cause of depletion, add water and anti-freeze mixture in the same mix ratio as the original solution.
- (6) Anti-freeze solutions absorb moisture, therefore be sure to close the container securely after use.
- (7) Anti-freeze and water should be changed every year.
- (8) Do not use an anti-freeze and a scale inhibitor at the same time. This may cause sludge to form which may damage the engine parts.

■ Checking and Cleaning Radiator and Oil Cooler

Daily or every 5 hours of operation, check to be sure the radiator net, radiator core, and oil cooler core.

Dirt or chaff to the radiator net, radiator core, oil cooler net or oil cooler core will decrease cooling performance.

- (1) To clean, turn the hook of radiator net, and take out the net and remove all foreign material.

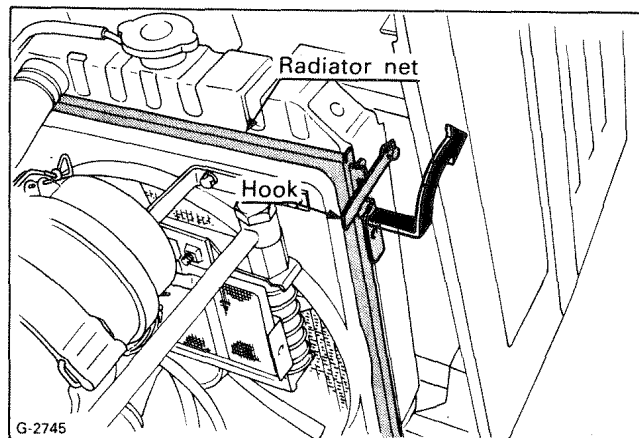

To clean, detach the oil cooler net and remove all the foreign materials from them.

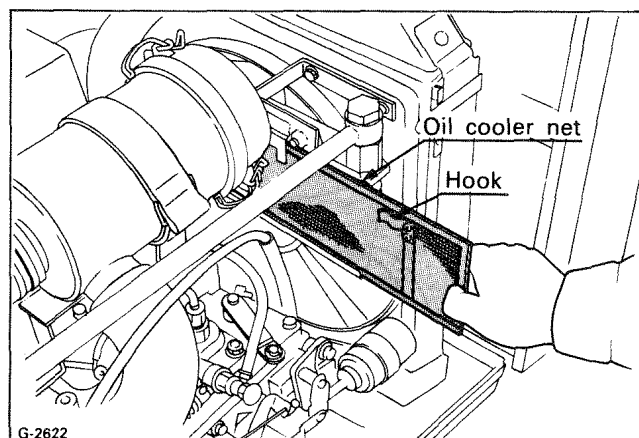

- (2) Remove the dust and dirt from between the fins and the tube.
- (3) Tighten the fan drive belt as necessary. (See page 35)
- (4) If scale forms in the radiator, clean with KUBOTA scale inhibitor or equivalent.

9.8 AIR CLEANER

- (1) The air cleaner uses a dry element, never apply oil.
- (2) Do not let dust build up to more than the half level in the dust cup. Detach the dust cup and clean out the dust once a week under normal conditions, everyday in dusty working conditions.
- (3) Do not touch the filter element except in cases where cleaning is required.
- (4) When cleaning this element, refer to the instructions below.
- (5) If the element is saturated with carbon or oil, replace the filter.
Remove the air cleaner rubber band, and the dust cup.

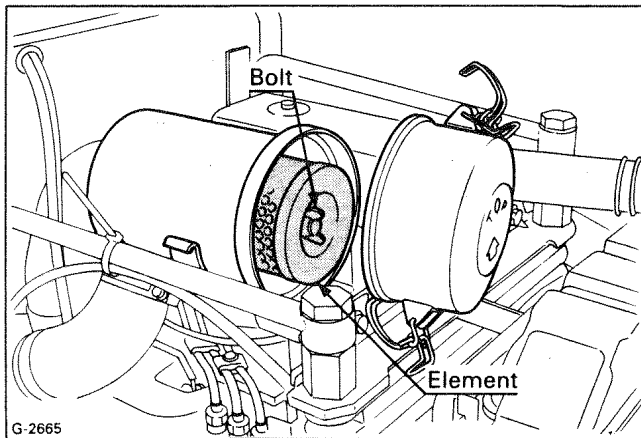
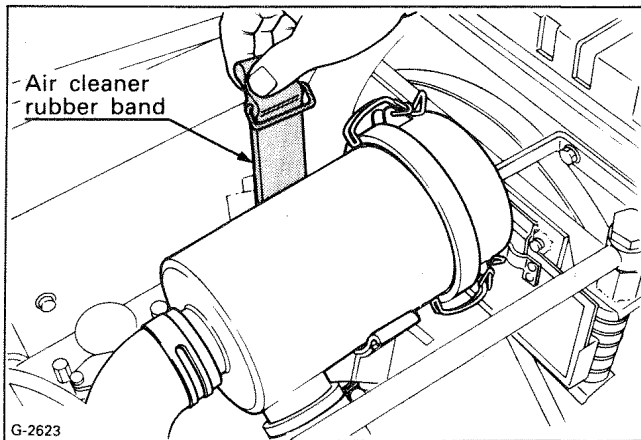

- (6) When cleaning the air filter element, handle with care (do not strike against hard surfaces), and reinstall the element correctly.
Damage to the element may cause serious problems in the engine.
- (7) Change the element once yearly or after every sixth washing, whichever comes first.

[IMPORTANT]

- (1) Be sure to refit the dust cup with the arrow ↑ (on the rear) upright. If the dust cup is improperly fitted, dust will pass by the dust cup and adheres directly to the element.
- (2) Do not run the engine with filter elements removed.

9.9 CLEANING AIR FILTER ELEMENT

- (1) To clean the element, use clean dry compressed air on the inside of the element.
Air pressure at the nozzle must not exceed 205 kPa (2.1 kgf/cm²; 30 psi).
Maintain reasonable distance between the nozzle and the filter.
- (2) To wash the elements, use KUBOTA Filter Cleaner, Donaldson ND-1500 Filter Cleaner, or its equivalent, which is especially effective on oily and soot-laden filters.
Follow instructions that are supplied with the filter cleaner.

9.10 BATTERY



CAUTION:

- Never remove the battery caps while the engine is running.
Keep electrolyte away from eyes, hands, and clothes. If you are splattered with it, flush with water immediately.

Mishandling the battery will shorten its service life and add to maintenance costs.

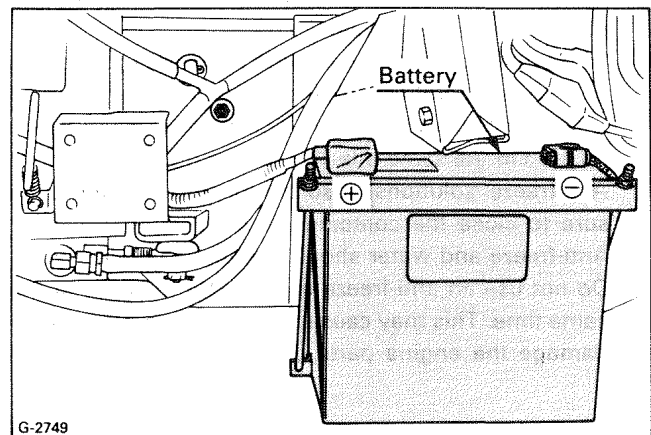

CAUTION:

- A battery, especially when charging, will give off hydrogen and oxygen gases which are very explosive. Keep open sparks and flames away from the battery at all times.

- (1) If the battery is weak, the engine will be difficult to start. It is important to check the battery daily and recharge before trouble occurs.
- (2) Be sure to maintain the correct level of electrolyte solution in the battery. Low electrolyte levels will damage the battery, while excessive electrolyte can spill over and damage the front mower body. If low, add distilled water.

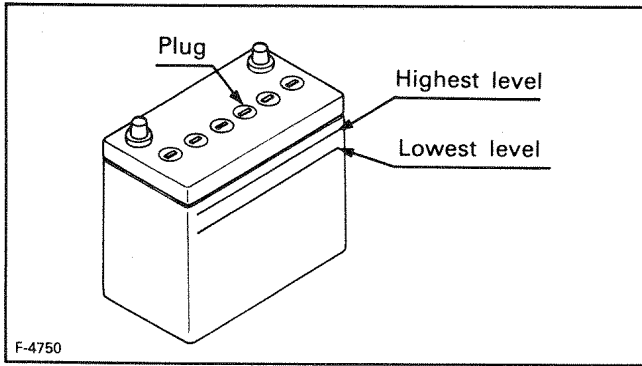

- (3) To slow charge the battery, connect the battery positive terminal to the charger positive terminal and the negative to the negative, then recharge in the standard fashion.
- (4) Perform boost charging only in emergencies. It will partially charge the battery at a high rate and in a short time. When using a boost-charged battery, it is necessary to recharge the battery as early as possible. Failure to do this will shorten the battery's service life.



CAUTION:

- To avoid accidental short circuit, be sure to attach the positive cable to the positive terminal before the ground cable is attached to the negative terminal.

[IMPORTANT]

- If the front mower is to be operated for a short time without a battery, do not, under any circumstances, interrupt the circuit by switching off the key switch before stopping the engine by means of fuel shut-off knob. Use additional current (lights) while engine is running. Insulate terminal of battery cable before starting by means of slave battery. Damage to alternator and regulator may result if these directions are not adhered to.

■ Directions for Storage

- (1) When storing the front mower for long periods of time, remove the battery from the front mower, adjust the electrolyte to the proper level and store in a cool, dry place.
- (2) The Maintenance Free Battery self discharges very slowly. But if it becomes weak, charge once every two month in hot seasons and once every four month in cold seasons.

[NOTE]

- Charge the battery if the specific gravity becomes under 1.240.

■ Maintenance Free Type Battery Charging

- (1) Connect positive terminal (+) of battery, with positive terminal of D.C. charging unit, and negative terminal (-) with negative terminal.
- (2) Charge it until the specific gravity becomes 1.280.
- (3) Batteries are preferably charged by the current shown below.

TYPE	Volts (V)	Number of plate per cell	Capacity at 20 H.R (A.H)	Volume of Electrolyte (ℓ)	Normal Charging Rate (A)
65D23R -MF	12	13	65	3.4	6.5

[IMPORTANT]

- (1) The vent plugs do not require removing if the liquid level is normal.
- (2) Charging rate must be under 10 (A).

9.11 FUSE

The front mower electrical system is protected from potential damage by fuses. There are a total of four fuses in the front mower electrical system. Three of the fuses are located in a fuse box under the seat. The fourth fuse is an in-line fuse. Refer to the illustrations and chart below for the location of the fuses and fuse amperage.

Inoperative electrical components may indicate that a fuse has been blown. A blown fuse indicates that there is an overload or short somewhere in the electrical system.

[IMPORTANT]

- Before replacing a blown fuse, determine why the fuse blew and make any necessary repairs. Failure to follow this procedure may result in serious damage to the front mower electrical system. Refer to the troubleshooting section of this manual or your Kubota dealer for specific information dealing with electrical problems.

If any of them should blow, replace with a new one of the same capacity.

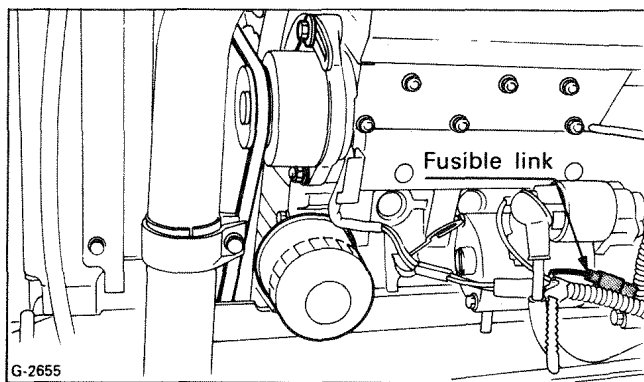

Check circuit against wrong battery connection.

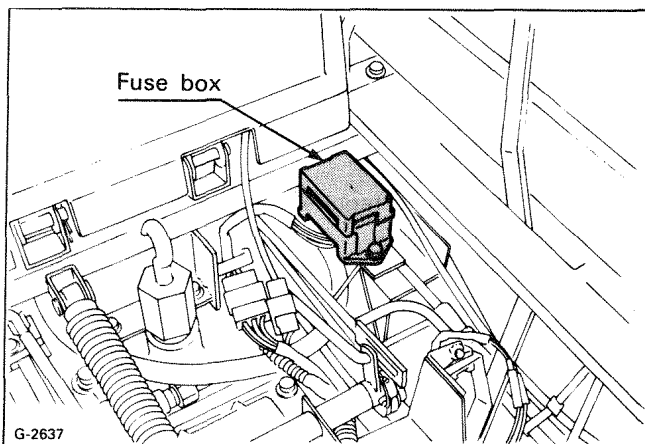

USE SPECIFIED FUSES ONLY.	HEAD LIGHT	10A
	REGULATOR CONTROL BOX INDICATOR	10A
	KEY STOP	15A

10. ADJUSTMENTS



CAUTION:

- When making adjustments, park the front mower on flat ground and apply the parking brake.

10.1 FAN DRIVE BELT

If the fan drive belt becomes loose, the engine may overheat.

Check the belt tension as shown below.

To adjust, loosen the adjusting bolt and tighten the tension bolt to lengthen the belt. After adjustment, tighten the adjusting bolt securely.

The belt should deflect approximately 0.4 in (10mm) when the center of the belt is depressed with a finger pressure of 98N (10kgf, 22lbs.).

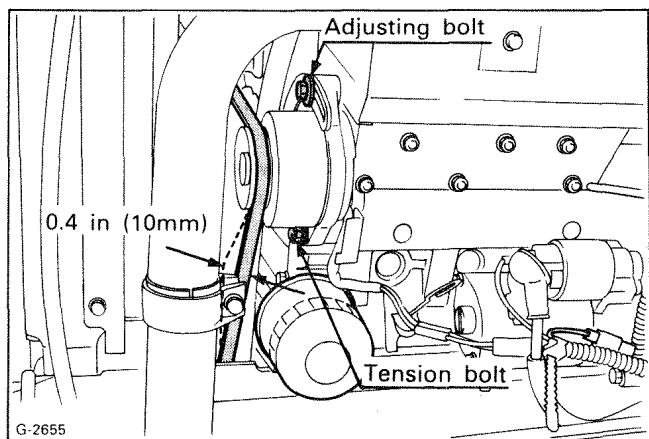

10.2 CLUTCH

Clutch free travel ranges from 0.8 to 1.2 in (20 to 30 mm). If the clutch becomes difficult to disengage or clutch pedal free travel decreases, adjust the length of the clutch rod after removing the pin. When the clutch is difficult to disengage, shorten the rod. When the clutch free travel is limited, extend the rod.

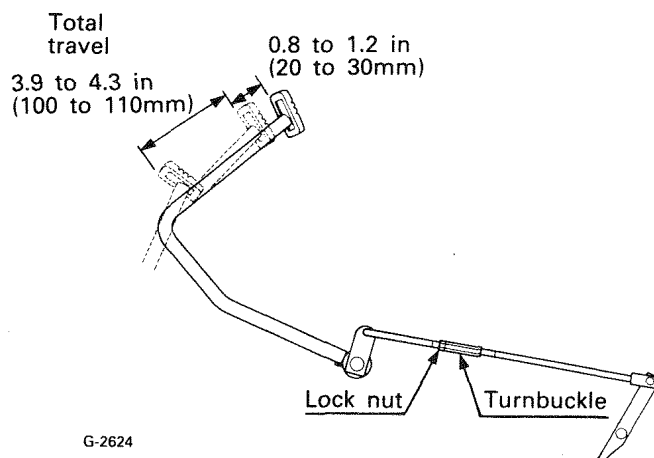

10.3 BRAKE

If brake pedal free travel becomes too great or travel varies between the right and left pedals, loosen the turnbuckle lock nut and turn the turnbuckle in the desired direction until the proper pedal free travel and balance is achieved. Right and left pedal free travel ranges from 0.4 to 0.8 in (10 to 20 mm). After adjustment, interlock the right and left brake pedals and tighten the lock nut securely.

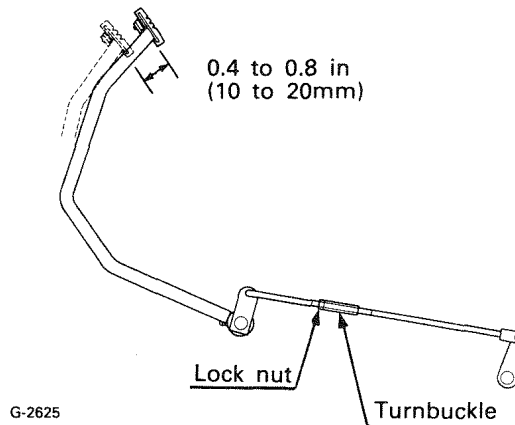

11. TROUBLESHOOTING

11.1 ENGINE TROUBLESHOOTING

■ When the engine is difficult to start

Causes	Remedy
Fuel is thick and doesn't flow	<ul style="list-style-type: none"> * Check the fuel tank and fuel filter. * Remove water, dirt and other impurities * As all fuel oil will be filtered by the filter, replace the filter if contaminated by water and dirt. * Check if fuel type is correct for cold weather. * See your KUBOTA dealer.
Air or water mixed in fuel system	<ul style="list-style-type: none"> * If air is in the fuel filter or injection lines, the fuel pump will not work properly. To obtain proper fuel injection pressure, check carefully for loosened fuel lines, cap nut, etc. * Loosen air vent screws on top of fuel filter and fuel injection pump to eliminate all the air in the fuel system.
Thick carbon deposits on orifice of injection nozzle.	<ul style="list-style-type: none"> * This is caused when water or dirt is mixed in the fuel. Clean the nozzle injection piece. Do not damage the orifice. * Check to see if nozzle is working properly. If not, install a new nozzle.
Valve clearance is incorrect	<ul style="list-style-type: none"> * Adjust valve clearance. See your KUBOTA dealer.
Leaking valves	<ul style="list-style-type: none"> * Grind valves.
Fuel injection timing is incorrect	<ul style="list-style-type: none"> * Adjust injection timing. See your KUBOTA dealer.
Engine oil becomes thick in cold weather and engine cranks slow.	<ul style="list-style-type: none"> * Change grade of oil according to the weather(temperature).
Low compression	<ul style="list-style-type: none"> * Bad valve or excessive wear of rings, pistons, and liners cause insufficient compression. Replace with new parts.
Battery is discharged and the engine will not crank.	<ul style="list-style-type: none"> * Charge battery. * Use decompression device. * In winter, always remove battery from front mower, charge fully and keep indoors. Install in front mower at time of use.

■ When power is insufficient

Causes	Remedy
Air cleaner is dirty or Fuel filter is dirty	<ul style="list-style-type: none"> * Clean the element every 100-200 hours of operation.
Carbon around orifice of nozzle piece	<ul style="list-style-type: none"> * Clean orifice and needle valve, being very carefully not to damage the nozzle orifice. * Check nozzle. If defective, replace with new parts.
Compression is insufficient. Leaking valves	<ul style="list-style-type: none"> * Bad valves and excessive wear of rings, pistons, and liners cause insufficient compression. Replace with new parts. * Grind valves.
Fuel is insufficient	<ul style="list-style-type: none"> * Check fuel system.
Overheating of moving parts	<ul style="list-style-type: none"> * Check lube oil system. * Check to see if lube oil filter is working properly. * Filter screens or elements deposited with impurities could cause poor lubrication. Clean screens. * Check to see if bearing clearances are within factory specs. * Check engine timing.
Valves not adjusted properly	<ul style="list-style-type: none"> * Adjust to proper valve clearance. See your KUBOTA dealer.
Fuel injection pressure is incorrect	<ul style="list-style-type: none"> * Adjust to proper pressure. See your KUBOTA dealer.

■ When color of exhaust is dark

See your KUBOTA dealer.

■ When engine suddenly stops

Causes	Remedy
Leak of fuel	* Check the fuel tank and refill if necessary. * Also check the fuel system for air or leaks
Bad nozzle	* If necessary, replace with a new nozzle.
Moving parts are overheated due to shortage of lube oil or improper lubrication	* Check amount of engine oil with dipstick. * Check lubricating oil system. * Check to see if element inside the lubricating oil filter (2) has become old and clogged. If necessary, replace with new element. * Check to see if the engine bearing clearances are within factory specs.

[IMPORTANT]

- When the engine has suddenly stopped, decompress the engine by the decompression knob and turn the engine lightly by pulling on the fan belt. If the engine turns easily without abnormalities, the cause of the trouble is usually lack of fuel or bad nozzle.

■ When engine must be stopped immediately

Causes	Remedy
Speed suddenly decreases or increases	* Check the adjustments and timing of injection and the fuel system.
Unusual sound is heard suddenly.	* Check all moving parts carefully.
Color of exhaust suddenly turns dark	* Check the fuel injection system, especially the fuel injection nozzle.
Bearing parts are overheated	* Check the lubricating system.
Oil light lights up during operation	* Check lubricating system. * Check to see if the engine bearing clearances are within factory specs. * Check the function of the regulating valve inside the oil filter. * Check pressure switch * Check filter base gasket

11.2 FRONT MOWER TROUBLE-SHOOTING

■ When Lift link does not move

Causes	Remedy
Transmission strainer is clogged	* Clean the strainer.
Lift link does not lower	* Check the hydraulic control valve.

■ Front mower operation is not smooth

Causes	Remedy
Hydrostatic transmission fluid is insufficient.	* Replenish oil.
Filter is clogged	* Replace the filter.
Strainer is clogged	* Clean the strainer.

■ Front mower does not move while engine is running

Causes	Remedy
High-low gear shift lever is at neutral.	* Check the high-low gear shift lever.
Parking brake is on.	* Release the parking brake.
Transmission fluid is insufficient.	* Replenish oil

■ Front mower moves when speed control pedal is not depressed. (Engine is operated.)

Causes	Remedy
Hydrostatic control linkage is not correctly adjusted.	* Ask your dealer for hydrostatic control linkage adjustment or pressure adjustment.

11.3 BATTERY TROUBLESHOOTING

Condition of Battery	Causes	Remedy	Precaution
Starter does not turn	Key is not "ON". Battery discharged.	Turn key "ON" Charge for long period by slow charging method until specific gravity of 1.26 is reached.	Do not overuse the battery and charge fully. Do not discharge. (Refrain from overdischarging)
	Charging of battery neglected.	Charge battery 1.26 at 68°F (20°C)	Check alternator rectifier.
	Defective alternator rectifier.	Repair alternator and replace defective rectifier. Charge battery completely.	Keep terminals clean, tighten well and apply grease to prevent corrosion.
	Dirty or corroded terminal contacts bad brushes, armature or field.	Clean terminal and tighten well. Replace.	
	Defective battery.	Replace battery.	
When starting, starter does not function, and lights dim quickly.	Battery not charged sufficiently.	Charge battery for long period by slow charging method.	Battery must be serviced properly before initial use.
Low electrolyte level.	Battery used with low electrolyte level.	Add distilled water and charge battery	Make routine checks of electrolyte
	Not serviced properly overcharged.	Charge for long period.	Do not overuse the battery and completely discharge.
	Defective alternator rectifier. Defective terminal contacts causing sulphation of electrodes.	Check alternator and rectifier and charge for long period by slow charging method.	Make routine checks of terminals, to make sure they are clean and tight.
Battery cannot be charged.	The current of the alternator during operation is too high causing plates to drop, warp or short circuit.	Decrease the charging current of alternator. Exchange defective battery.	Check charging current of alternator.
	Defective battery.	Obtain replacement battery.	
Corrosion of terminals.	Not serviced properly.	Clean corrosion from terminals and tighten well.	Keep terminals clean and well tightened. Apply grease to prevent corrosion.
Electrolyte decreases rapidly	Overcharging.	Check charging out put.	
	Battery cracked.	Replace battery	Secure battery to front mower so it will not move.

12. LONG-TERM STORAGE



CAUTION:

- (1) When storing, remove the key from the key switch to avoid unauthorized persons from operating the front mower and getting injured.
- (2) To avoid the danger of exhaust fume poisoning, do not operate the engine in a closed building without proper ventilation.

When the front mower will not be operated for longer than two or three months, clean the front mower and perform the following before storage.

- (1) Repair any parts as needed.
- (2) Check nuts and bolts, tighten as necessary.
- (3) Apply grease or engine oil to the parts most likely to rust.
- (4) Remove any ballast weight.
- (5) Inflate the tires to a little above the recommended pressure levels.
- (6) Change the engine oil and run the engine for five minutes so that the oil circulates throughout the entire system.
- (7) Stop the engine by fully pulling the engine stop knob.
- (8) Drain the radiator. Flush and refill with new coolant.
- (9) Lock the clutch pedal with the latch.

If the front mower is stored for a long period with the clutch left engaged, the clutch disc may rust, rendering it inoperative.

- (10) Lower the implement to the ground.
- (11) Remove the battery from the front mower, recharge it, adjust the electrolyte to the proper level, and store in a cool, dry place.
- (12) The battery discharges over time even while in storage. Recharge it once a month in hot seasons and once every two months in cold seasons.
- (13) Store the front mower in a dry and sheltered area. Cover the front mower with a tarpaulin.
- (14) To avoid the rust of power steering cylinder. Turn the steering wheel from lock to lock once a month.

[IMPORTANT]

- When cleaning the front mower, stop the engine. If you must clean the front mower with the engine running, care should be taken not to allow water to enter the air cleaner. Engine trouble may occur if water enters the engine.

13. LUBRICANT SPECIFICATIONS

■ Engine Oil

Oil used in the engine should have an American Petroleum Institute (API) / SAE Classification of service CC or CD. The chart below shows the correct weight oil to be used at various temperature conditions:

ENGINE OIL VISCOSITY CHART

Below 0°C (32°F)	SAE 10W or 10W-30
0°~25°C (32°~77°F)	SAE 20 or 10W-30
Above 25°C (77°F)	SAE 30 or 10W-30

■ Others

Grease fittings	Multipurpose type grease
Rear Wheel Drive Unit	SAE 80 or 90 weight gear oil

■ Transmission Oil

The oil used to lubricate the transmission is also used as hydraulic fluid. To insure proper operation of the hydraulic system and complete lubrication of the transmission, it is important that a multi-grade transmission fluid be used in this system. The following are recommended oils, by brand name, that may be used in the transmission hydraulic system.

Maker	Brand Name
Exxon	Torque-Fluid 56
Shell	Donax TD, TM
Union	Hydraulic / Tractor Fluid
Mobil	Mobil Fluid 423,350

KUBOTA LUBRICANTS

THE BEST CHOICE SINCE BUYING YOUR KUBOTA

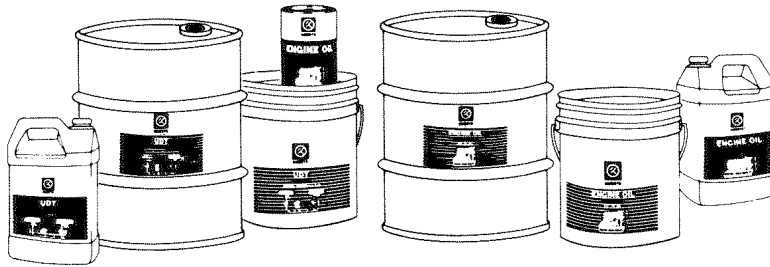

When you think of Kubota diesel tractors, you think of quality, performance and service. Now you can also think of Kubota lubricants.

Now, Kubota offers a lubricant line to use with all the Kubota tractors from 10 to 85 PTO horsepower. The Kubota lubricant line consists of a 15W-40 or 10W-30 engine oil and a universal transdrdraulic fluid called "UDT." A variety of sizes are available to meet your small and larger needs, in 1 quart, 2 gallon, 5 gallon and 55 gallon containers.

Next time you need to pour it on, pour it in with Kubota lubricants.

Kubota lubricants, tractor tough quality.



KUBOTA[®]
Nothing like it on earth.[™]

14. WIRING DIAGRAM

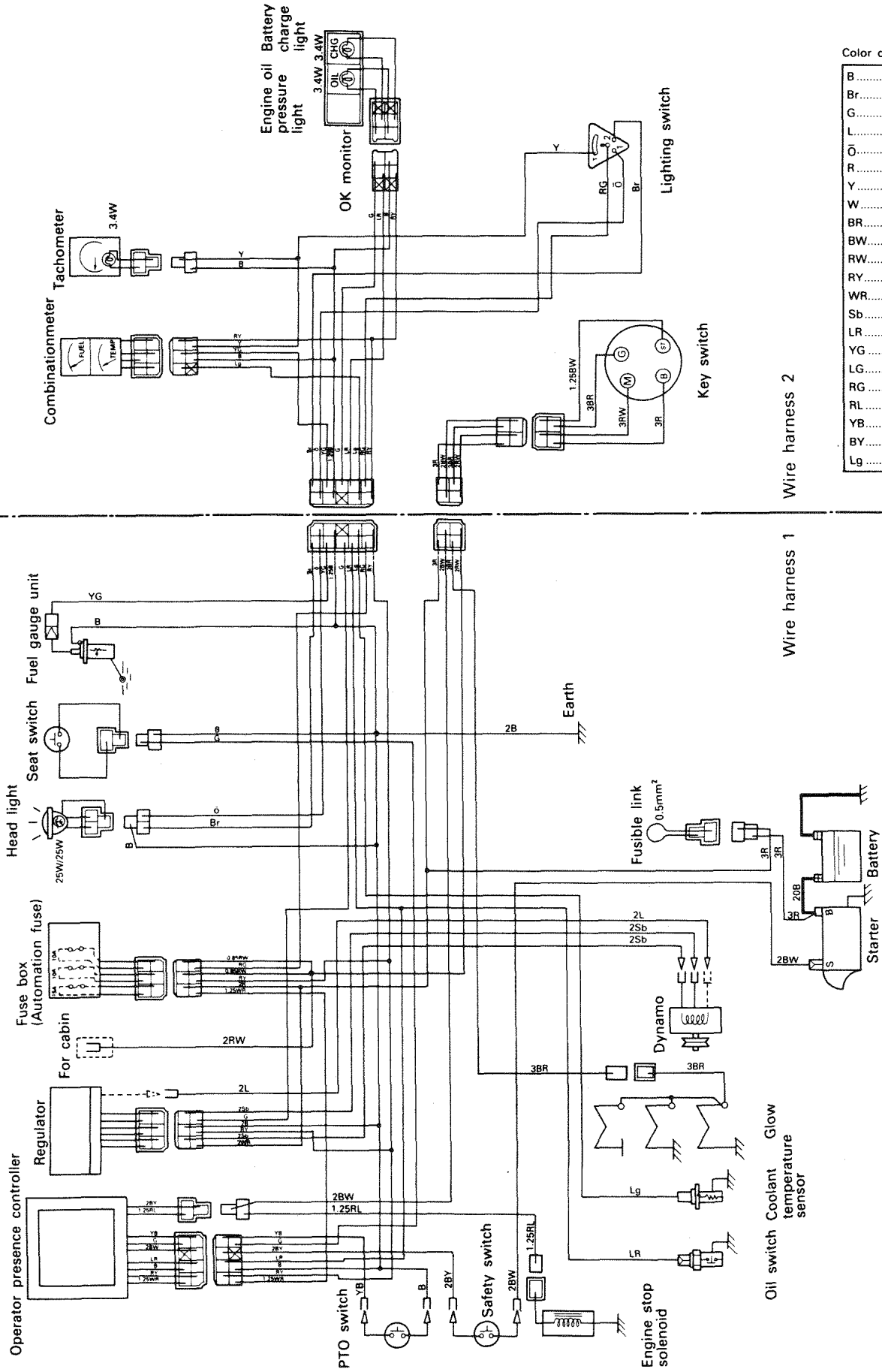

Color of Wire Harness

B	Black
Br	Brown
G	Green
L	Blue
O	Orange
R	Red
Y	Yellow
W	White
BR	Black/Red
BW	Black/White
RW	Red/White
RY	Red/Yellow
WR	White/Red
Sb	Sky blue
LR	Blue/Red
YG	Yellow/Green
LG	Blue/Green
RG	Red/Green
RL	Red/Blue
YB	Yellow/Black
BY	Black/Yellow
Lg	Light green

Wire harness 2

Wire harness 1

INDEX

A

- Air cleaner 32
- Anti-freeze 31

B

- Ballast 18
- Battery 32
- Battery charge light 9,22
- Battery troubleshooting 38
- Bleeding, fuel line 25
- Brake adjustment 35
- Brake pedals 13
- Brake pedal shaft, greasing 29

C

- Charging, maintenance free type battery 33
- Clutch adjustment 35
- Clutch pedal 12
- Clutch release hub, greasing 29
- Controls 11
- Coolant 22,30
- Coolant temperature gauge 9
- Cooling system cleaning 31

D

- Daily check 23
- Differential lock pedal 13
- Differential lock 22
- Directions for use of power steering 21

E

- Engine oil 26
- Engine oil filter cartridge, change 27
- Engine oil pressure light 9,22
- Engine stop knob 10
- Engine troubleshooting 36
- Exhaust fumes 22

F

- Fan drive belt 35
- Fuel 22,25
- Fuel filter bowl, cleaning 26
- Fuel gauge 9
- Fuse 34

H

- Head light switch 9
- High-low gear shift lever 12
- Hood 14
- Hour meter 9
- Hydraulic control lever 13

I

- Instrument panel and controls 8

K

- Key switch 8

L

- Lift height set screw 15
- Lift link 15
- Lift link arm shaft, greasing 29
- Lifting rod 15
- Long-term storage 39
- Lubricants 23
- Lubricant specifications 40

M

- Maintenance check list 24

O

- Operating the engine 19
- Operating new front mower 7
- Operator presence control switch 14
- Operator's seat 14

P

- Parking 21
- Parking brake lever 13
- PTO gear shift lever 12
- Product identification number 5

R

- Radiator 30
- Rear wheel drive lever 12
- Rear axle differential case oil, changing 29
- Rear axle gear case oil, changing 29

S

- Safe operation 1
- Safety 1-4
- Safety labels 4
- Seat adjuster, greasing 29
- Servicing of front mower 5
- Specifications 6
- Speed control pedal 11
- Speed set lever 12
- Starting 19
- Stopping 19,21
- Switches 8

T

- Tachometer 9
- Throttle lever 11
- Tires 18
- Toe-in 18
- Trouble shooting 36
- Transmission fluid 27
- Transmission strainer 28
- Tread 17

W

- Warm up 20
- Wheel adjustment 17
- Wiring diagram 41

Kubota, Ltd. is . . . Since its inception in 1890, Kubota, Ltd. has grown to rank as one of the major firms in Japan. To achieve this status, the company has through the years diversified the range of its products and services to a remarkable extent, until today, 19 plants and 19,000 employees produce over 1,000 different items, large and small. All of these products and all of the services that accompany them, however, are unified by one central commitment. Kubota makes products which, taken on a national scale, are basic necessities. Products which are indispensable, products intended to help individuals and nations fulfill the potential inherent in their environment. Kubota is the Basic Necessities Giant. This potential includes water supply, food from the soil and from the sea, industrial development, architecture and construction, transportation. Thousands of people depend on Kubota's know-how, technology, experience and customer service. You too can depend on Kubota.

**Kubota Makes all Kinds
of Agricultural
Machinery for Seeding
to Harvesting.**

- Radiator-Cooled Diesel Engines
- Air-Cooled Gasoline Engines
- Power Tillers ● Farm Tractors ● Power Sprayers
- Power Mist Blower & Dusters ● Brush Cutters
- Dairy Machines ● Sprinklers ● Rain Guns ● Pumps
- Others

7661762110