

# Foreword

You are now the proud owner of KUBOTA L245-L245DT. This tractor is a product of Kubota quality engineering and manufacturing. It is made of the finest materials, to exact specifications, and under rigid production methods. It will give you long, satisfactory service. To obtain the best use of your tractor, please read this manual carefully. It will help you become familiar with the operation of the tractor, it contains many helpful hints about tractor maintenance. It is Kubota's policy to utilize as quickly as possible every advance in our research. The immediate use of new techniques in the manufacture of products may cause some small parts of this manual to be outdated. Kubota agents and dealers will have the most up-to-date information.

Please do not hesitate to consult with them.

**LIMITED  
ONE YEAR OR SIX HUNDRED HOUR  
WARRANTY**

All Kubota brand tractors and implements distributed by Kubota Tractor Corporation (KTC), a California corporation with offices at 300 West Carob Street, Compton, California, 90220, shall carry the following warranty:

**(a) Products Covered**

KTC Warrants to be free from defects in material and workmanship all parts and structural components (except as noted below) of all Products manufactured by Kubota, or manufactured for KTC, provided such Products are put to normal and proper use and receive the maintenance service as specified by Kubota in the owners manual.

**(b) Duration**

- (1) Tractors: This warranty shall be in effect (for purchasers other than those in the rental business) for One Year from the date of delivery or until the Product has been operated for Six Hundred Hours, which ever comes first. For purchasers in the business of renting Kubota Products to third party users, this warranty shall be in effect for Six Months or Six Hundred Hours of operation, which ever comes first.
- (2) Implements: This warranty shall be in effect for six months from date of delivery. For purchasers in the business of renting Kubota Products to third party users, this warranty shall be in effect for ninety days.

**(c) Replacement Parts Warranty**

KTC parts which are furnished and installed under this warranty are themselves within the coverage of this warranty for the duration of the original one year warranty period or for ninety days after installation, which ever period shall expire last.

**(d) Exclusions**

This warranty excludes the following components or parts of Products as modified:

- (1) Battery: The Battery is warranted for a period of three months under proper maintenance from the date of delivery. After the expiration of such three month warranty period, the customer shall pay only a pro-rata portion of the cost of the replacement or repair of a battery occurring within twelve months from the date of purchase. The pro-rata portion of the cost that the customer shall pay, shall be in the proportion to the total cost as the number of months elapsed since the date of his purchase from the dealer is to twelve months.
- (2) Light bulbs, preheater plugs, indicator and resistance coil, cleaner elements, lubricating and hydraulic oil, and cleaning of fuel line.

**(e) Products Not Covered**

- (1) This warranty does not extend to used Products. The terms apply only to new and unused Products purchased from all authorized Kubota dealers.
- (2) This warranty does not apply to Products which have been subjected to alteration, modification, neglect, unauthorized repair, or misuse in any way.

WARRANTY  
ONE YEAR OR SIX HUNDRED HOURS  
WHATEVER COMES FIRST

All Kubota brand tractors and implements manufactured by Kubota Tractor Corporation (KTC), a California corporation with its principal office at 100 West Carob Street, Compton, California, 90220, shall carry the following warranty:

**(a) Products Covered**

KTC Warrants to be free from defects in material and workmanship all parts and structural components (except as noted below) of all Products manufactured by Kubota, or manufactured for KTC, provided such Products are put to normal and proper use and receive the maintenance service as specified by Kubota in the owners manual.

**(b) Duration**

- (1) Tractors: This warranty shall be in effect (for purchasers other than those in the rental business) for One Year from the date of delivery or until the Product has been operated for Six Hundred Hours, which ever comes first. For purchasers in the business of renting Kubota Products to third party users, this warranty shall be in effect for Six Months or Six Hundred Hours of operation, which ever comes first.
- (2) Implements: This warranty shall be in effect for six months from date of delivery. For purchasers in the business of renting Kubota Products to third party users, this warranty shall be in effect for ninety days.

**(c) Replacement Parts Warranty**

KTC parts which are furnished and installed under this warranty are themselves within the coverage of this warranty for the duration of the original one year warranty period or for ninety days after installation, which ever period shall expire last.

**(d) Exclusions**

This warranty excludes the following components or parts of Products as modified:

- (1) Battery: The Battery is warranted for a period of three months under proper maintenance from the date of delivery. After the expiration of such three month warranty period, the customer shall pay only a pro-rata portion of the cost of the replacement or repair of a battery occurring within twelve months from the date of purchase. The pro-rata portion of the cost that the customer shall pay, shall be in the proportion to the total cost as the number of months elapsed since the date of his purchase from the dealer is to twelve months.
- (2) Light bulbs, preheater plugs, indicator and resistance coil, cleaner elements, lubricating and hydraulic oil, and cleaning of fuel line.

**(e) Products Not Covered**

- (1) This warranty does not extend to used Products. The terms apply only to new and unused Products purchased from all authorized Kubota dealers.
- (2) This warranty does not apply to Products which have been subjected to alteration, modification, neglect, unauthorized repair, or misuse in any way.

**(f) Remedies for Breach**

In the event of a defect in the material or workmanship of a Product, KTC will replace or repair, without charge for parts or labor, any part or parts which have become defective under normal and proper use accompanied by proper maintenance as specified by Kubota. The purchaser will be responsible for any and all costs of transporting the Product to an authorized Kubota dealership.

**(g) Limitation on Implied Warranty**

All warranties implied by law, including warranties of merchantability or fitness for a particular use, are limited in duration to the duration of the express warranty on the Products, as expressed in Paragraph (b).

**(h) Limitation on Consequential Damages**

In no event shall any purchaser or user be entitled to recover under this warranty for incidental or consequential damages, including, but not limited to, loss of crops, inconvenience, rental or replacement equipment, loss of profits, or other commercial loss.

**(i) Procedure to Obtain Performance**

In the event of a defect in the material or workmanship, a purchaser entitled to enforce the terms of this warranty should take the following steps:

- (1) Notify the Kubota dealer who sold the Product in question or other Kubota dealer if the original dealer is not convenient or available.
- (2) Transport the Product to the dealer's business location. If the dealer contacted is not the original dealer of the Product, accompany the Product with such proof of purchase date as available.

If the Product is still under this warranty and the defect is covered by the terms of this warranty, the dealer will assume responsibility for performance under this warranty.

**(j) Legal Rights of Purchaser**

This warranty gives specific legal remedies, and the purchaser may also have other legal rights which vary from state to state.

**(k) Authority of Dealers**

KTC dealers are not authorized to modify, extend, limit the terms of this warranty. KTC will not assume responsibility for any other warranty terms stated by any person in connection with the sale of the Products.



# For Safe Operation

Please read these safety tips. Improper use of the tractor and its equipment can result in injury. To reduce this possibility, pay complete attention to the job at hand, and observing the following precautions. If you can prevent an accident, your time will have been spent well.

1. When starting engine, depress clutch pedal, where safety start switch is installed, by your left foot while sitting in the tractor seat properly.
2. Never attempt depressing of clutch pedal by hand or foot without sitting on the seat.
3. Depressing of clutch pedal and turning of starter switch must be done by one person from operator's seat.
4. For travelling on roads, be sure to have both the brakes interlocked. Applying only one brake will result in sudden turning, which may tip the tractor over.
5. Reduce speed when turning or applying individual brakes.  
Do not attempt to turn too sharply or at too fast a speed when using the individual brakes.
6. Keep all shields and guards in place.
7. This vehicle is not for street or highway use.
8. Keep other people and pets a safe distance away from the tractor.
9. Do not stand near machine while in motion.
10. Keep hands, feet and clothing away from power driven parts.
11. Always wear relatively tight and belted clothing when operating the tractor.  
Loose jackets, shirts, sleeves or other loose clothing should not be permitted because of the danger of catching them in moving parts or controls.
12. Never allow passengers to ride or board the tractor at any time.
13. Do not allow children to operate machine, or adults without proper instruction.
14. Always drive slowly over rough ground.  
Drive at speeds slow enough to insure your safety.
15. Confirm what is behind you before backing the tractor.
16. Keep alert for holes, ditches or other terrain irregularities.
17. Operate the tractor at the safe speed.
18. Take care when operating the tractor on hillsides and curves to prevent tipping.  
It is dangerous to travel down a slope by just depressing the brake pedals while disengaging the clutch.
19. Do not start or stop suddenly when going up or down hills.
20. Before operating an implement with this tractor, read the operation and safety suggestions in the operator's manual carefully.
21. Clear work area of object which might be picked up and thrown.
22. Repair any damage before restarting and operating the equipment.
23. When using a mower or other attachment, stop and inspect for damage after striking a foreign object.
24. Refuel your tractor only with the engine turned off.
25. Never smoke while refueling.
26. Fill the tank out of doors and wipe up spilled fuel. Replace the cap securely.
27. Do not operate the engine where ventilation is poor as noxious exhaust gas is easy to collect. While running the engine, protect workers and animals from exhaust gas.
28. Always turn off the key switch when working on the electrical system or when making adjustments to the engine or mounted attachments.
29. Before dismounting from the tractor:
  - \* Shift the transmission to neutral.
  - \* Set the parking brake.
  - \* Disengage the PTO clutch.
  - \* Stop the engine.
  - \* Remove the key switch.
30. Always use the seat belt only when the roll bar is installed. Never use the seat belt if roll bar is removed from the tractor.

# CONTENTS

1. Servicing of Tractor . . . . .	1
2. Specifications . . . . .	2
3. Handling New Tractor . . . . .	3
4. Instrument Panel and Controls . . . . .	4
4-1 Instrument Panel . . . . .	4
4-2 Controls . . . . .	6
5. Operation . . . . .	9
5-1 Prestarting Inspection . . . . .	9
5-2 Starting the Engine . . . . .	10
5-3 Stopping the Engine . . . . .	11
5-4 Operating the Tractor . . . . .	11
5-5 Stopping the Tractor . . . . .	11
5-6 Parking . . . . .	11
5-7 Turning . . . . .	12
5-8 Check While Operating . . . . .	12
5-9 Operating on Public Roads . . . . .	12
5-10 Operating on Slopes . . . . .	12
5-11 Handling the Tractor on the Farm . . . . .	13
5-12 Use of the Differential Lock . . . . .	13
6. Hydraulic System . . . . .	14
7. Three-Point Hitch . . . . .	16
8. Storage . . . . .	17
9. Maintenance and Checks . . . . .	18
9-1 Engine Lubrication . . . . .	18
9-2 Air Cleaner . . . . .	20
9-3 Radiator . . . . .	20
9-4 Battery . . . . .	22
9-5 Diagnosis of Engine Trouble . . . . .	25
9-6 Transmission Lubrication . . . . .	26
9-7 Adjusting Clutch . . . . .	27
9-8 Check Tire Pressure . . . . .	27
10. Change of Wheel Treads . . . . .	28
10-1 Change Front Wheel Tread . . . . .	28
10-2 Change Rear Wheel Tread . . . . .	29
11. Wiring Diagram . . . . .	30
12. Maintenance Check List . . . . .	31

# 1 Servicing of Tractor

Your dealer is interested in your new tractor and has the desire to help you get the most value from it. After reading this manual thoroughly, you will find that you can do many of the regular service jobs quickly and easily.

However, when in need of parts or major service, be sure to see your KUBOTA dealer.

When in need of parts, be prepared to give your dealer both the tractor and engine serial numbers.

The tractor serial number is located on the transmission housing on the right-hand side of the tractor. The engine serial number is located on the engine crankcase, right side.

Locate the serial numbers now and record them in the space provided.

## KUBOTA TRACTOR

Tractor Serial No. L 245 - 10257

Engine Serial No. \_\_\_\_\_

Date of Purchase 7/6/77

(To be filled in by purchaser)

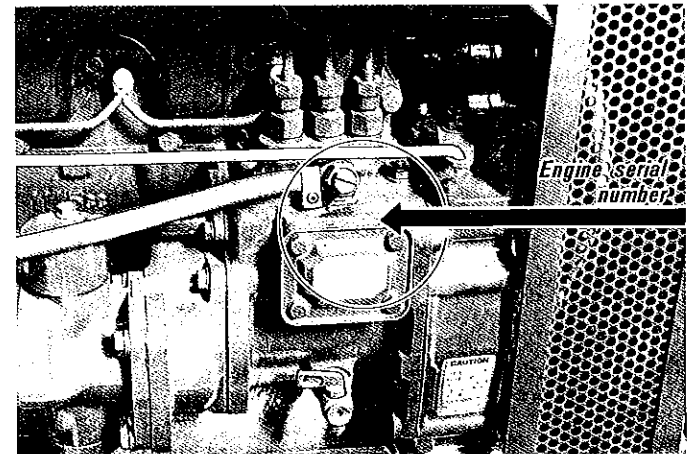
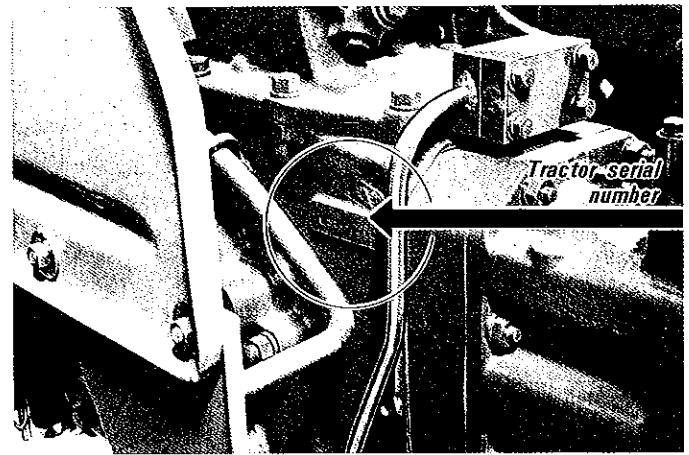
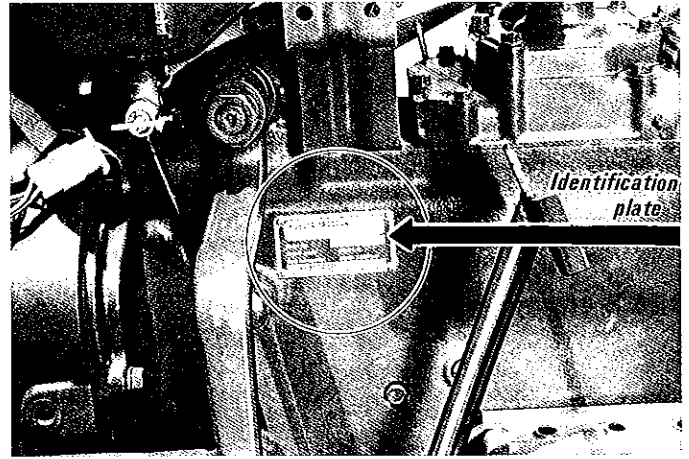

# 2 Specifications

Howe ACTION 03 682-9272-

## ■ Engine

Model	KUBOTA DH1101-A
Type	Vertical, water cooled 4 cycle diesel engine
Number of cylinders	3
Bore & Stroke	3" x 3-15/64" (76 x 82mm)
Total displacement	68.3 Cu. in. (1115cm <sup>3</sup> )
Horse power	Bare 25 HP (18.7 KW)
Rated rpm (r/s)	2800 rpm
Starting system	Electric starter with battery, glow plug and decompression device
Lubricating	Forced lubrication by trochoidal pump
Cooling	With pressurized radiator

## ■ Capacities

	L245	L245DT
Fuel tank	5.8 Gallons (22ℓ)	
Cooling system	7.0 Quarts (6.6ℓ)	
Engine crankcase	5.2 Quarts (4.9ℓ)	
Steering box	0.3 Quarts (0.3ℓ)	
Transmission	23 Qts. (22ℓ)	24 Qts. (23ℓ)
Front axle diff. case (right, left)	—	1.1 Qts. (1.1ℓ)
Front axle gear case (right, left)	—	0.8 Qts. (0.8ℓ)

## ■ Lubricants

Engine crankcase	Engine oil DS (CD) Above 77°F (25°C) / SAE 30 Between 32°~77°F (0°~25°C) / SAE 20 Below 32°F (0°C) / SAE 10W, 10W-30
Transmission	Gear oil SAE 80
Steering box	Gear oil SAE 80
Front axle case	Gear oil SAE 90

## ■ Dimensions & Tires

	L245F	L245T	L245DT
Over-all length	101-3/8 in (2575 mm)	99-1/4 in (2520 mm)	101-3/8 in (2575 mm)
Over-all width	51-5/8 in (1310 mm)	58-1/2 in (1485 mm)	51-5/8 in (1310 mm)
Over-all height	53-3/4 in (1365 mm)	51-3/4 in (1315 mm)	78 in (1980 mm)
Min. ground clearance	13-5/8 in (345 mm)	11-5/8 in (295 mm)	12 in (305 mm)
Wheel base	63 in (1600 mm)	63 in (1600 mm)	59-7/8 in (1520 mm)
Thread front	37-3/4 in (960 mm)	41-7/8 in (1045 mm)	39-3/4 in (1010 mm)
rear	~51-5/8 in ~1310 mm 41-1/8 in (1045 mm) ~55-3/8 in ~1405 mm)	44-1/2 in (1130 mm)	41-1/8 in (1045 mm) ~55-3/8 in ~1405 mm)
Weight (with 3 point-hitch)	1825 lbs. (830 kgf; 8.1KN)	1770 lbs. (805 kgf; 7.9KN)	2000 lbs. (910 kgf; 8.9KN)
Tire front	FSR 5.00-15 4PR	AGP 20x8.00-10 4PR	FSLW 7-16 4PR
rear	FSLW 11.2/10-24 4PR	AGS 13.6-16 4PR	FSLW 11.2/10-24 4PR

(Specifications and design subject to change without notice.)

■ Clutch	Dry single plate
■ Steering	Ball screw type
■ Transmission	Gear shift type (8 Forward, 2 Reverse)
■ Brake	Single right and left independent with wet disk.
■ PTO system	SAE 1-3/8" Clockwise from rear 3 speeds at engine 2430 rpm (with over running clutch) 1st 540 rpm 2nd 702 rpm 3rd 1007 rpm
■ Fuel	No. 2 diesel fuel

## ■ Travel Speeds

at rated engine r.p.m. with 11.2/10-24 tires.

Forward 1st	0.82 mph ( 1.31 km/h)
2nd	1.06 mph ( 1.71 km/h)
3rd	1.52 mph ( 2.45 km/h)
4th	2.64 mph ( 4.25 km/h)
5th	3.49 mph ( 5.62 km/h)
6th	4.54 mph ( 7.30 km/h)
7th	6.51 mph (10.48 km/h)
8th	12.09 mph (19.46 km/h)
Reverse 1st	1.39 mph ( 2.23 km/h)
2nd	5.93 mph ( 9.55 km/h)

# 3 Handling New Tractor

How a new tractor is handled and maintained determines the life of the tractor.

A new tractor just off the factory production line has been, of course, well fitted and tested, but the various parts cannot be said to be accustomed to specially severe type of work, so care should be taken to operate the tractor for the first 100 hours at slower speed and avoid excessive work or operation until the various parts become well "broken in".

The manner in which the tractor is handled while new greatly affects the life of your tractor. Therefore, to obtain the maximum performance and the longest life of the tractor, it is very important in the handling of the new tractor.

In handling a new tractor, the following precautions should be well observed.

■ **Do not operate the tractor at full speed for the first 100 hours.**

- \* Do not start quickly nor apply the brakes suddenly.
- \* In winter, run the tractor after fully warming up the engine.
- \* Do not run at speeds faster than necessary.
- \* On bad roads, slow down to suitable speeds. Do not operate the tractor at fast speed.

The above precautions are not limited only to new tractors, but to all tractors. But it should be especially observed in case of new tractors.

■ **Supply and exchange of lubricating oils**

The lubricating oil is specially important in the case of a new tractor because as the various parts are not "broken in" and are not accustomed to each other, small metal grit may develop during the operation of the tractor; and this may wear out or damage the parts. Therefore, care should be taken to exchange the lubricating oil a little earlier than would ordinarily be required.

For further details of exchange interval hours, see check list.

■ **Read "For Safe Operation" to assure Safe Operation.**

Please read "For Safe Operation."

The precautions are suggested to help prevent accidents.



# 4 Instrument Panel and Controls

## 4.1 INSTRUMENT PANEL

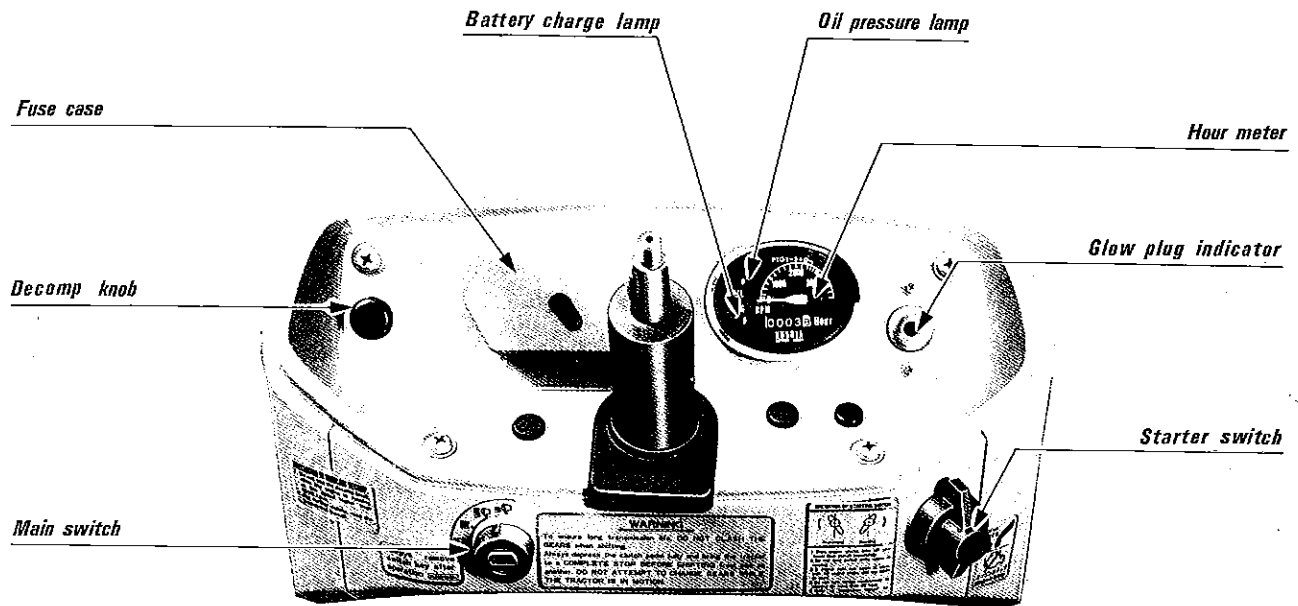

### ■ Main Switch

The main switch is separate from the starting switch. By turning the main switch one stage clockwise, the electric circuit starts functioning.

When turned to the second stage, the head-light is turned on. When turned further to the third stage, the head-light would be dimmed and the angle of the light would be lowered. When the tractor is not to be used, do not leave the key inserted, but always remove the key and carry it with you.

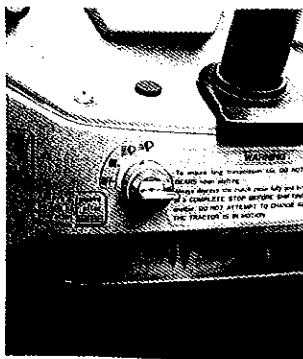

- OFF..... Electric circuit is open.
- ON ..... Electric circuit is closed.
- ☞..... Head lights "ON".
- ☞..... Head lights dimmed.

### ■ Starter Switch

When the starter switch is turned to the right, the engine will catch. When released, the switch will return to its neutral position.

When the starter switch is turned to the left, the pre-heating coil will activate, and the combustion chamber will be pre-heated.

When released, the switch will return to its former position.

### [Attention]

Because of the safety device, the engine may not be started except when the clutch is disengaged.

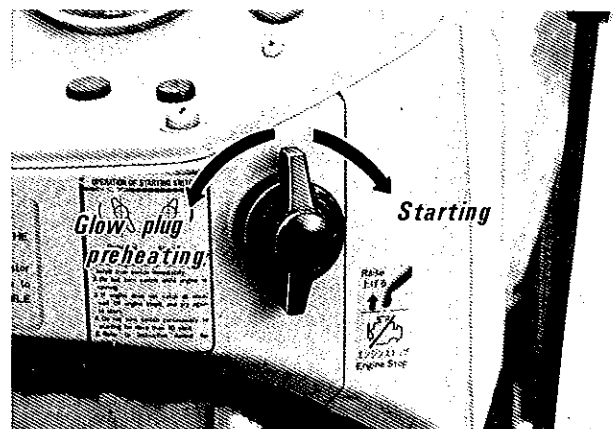

### ■ Glow Plug Indicator (Pre-heating Indicator)

When the starter switch is turned to the left, the glow plug indicator becomes red. This shows the condition of pre-heating in the combustion chamber.

### ■ Decompression Knob

If the battery becomes weak and it is difficult to turn the starter (or when it is difficult to start in cold weather), pull the decompression knob to release the compression of the engine.

Then it should be easy to start the engine.

### ■ Oil Pressure Lamp

This lamp is for the purpose of indicating whether the pressure of the engine oil being sent to the various parts is normal or not. When the main switch is turned, the lamp lights up. When the starting switch is turned, the engine starts and when the oil starts to circulate under normal pressure, the light will go off.

### ■ Battery Charge Lamp

The battery charge lamp serves to indicate whether the charging of the battery is conducted properly or not. The lamp is on while the battery is discharging. So, it lights up when the main switch is turned on but it goes off as soon as the engine is cranked up and starts charging the battery.

### ■ Hourmeter

\*Hourmeter

This meter shows the number of hours the tractor has been used with the engine RPM at 2800 rpm. When the last figure on white background is multiplied by six, it will show the time in minutes.

For example: 0170 (1) ----- 170 hours and 6 minutes used.

\*RPM speed

This indicates the revolution per minute of the engine.

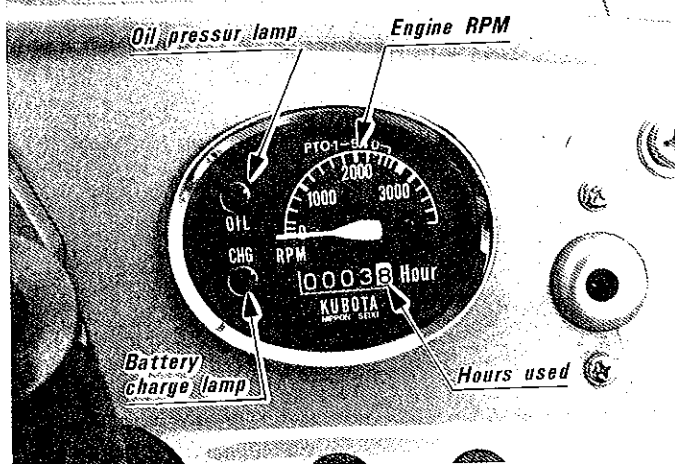

### ■ Fuse Case

There are 5 ampere and 10 ampere fuses in the fuse box to safeguard the electric circuit. There are also spare fuses:

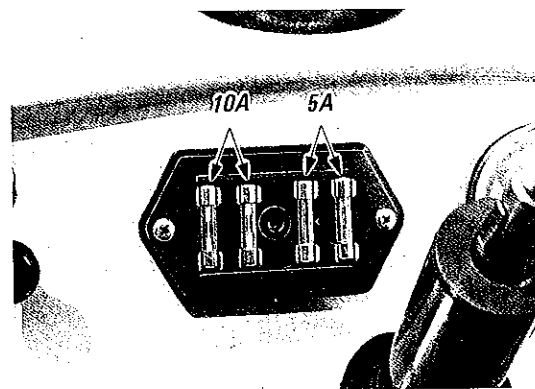

## 4.2 CONTROLS

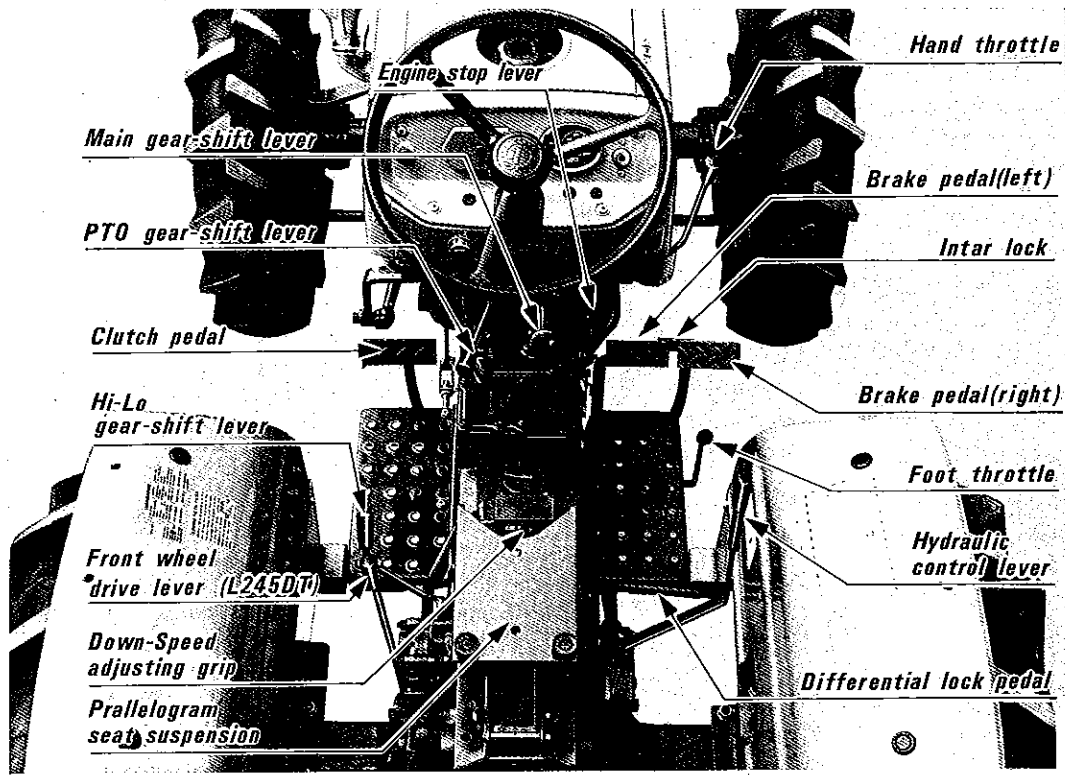

### ■ Main Gear Shift Lever & Hi-Lo Gear Shift Lever

The main gear shift lever pattern is in the form of an "H". The hi-lo gear shift lever moves two stages, "high" and "low". By combination and use of the main gear shift lever and the hi-lo gear shift lever, it is possible to obtain four speeds forward in "high" range and four speeds forward in "low" range, or a total of eight speeds forward; and two speeds reverse, high and low.

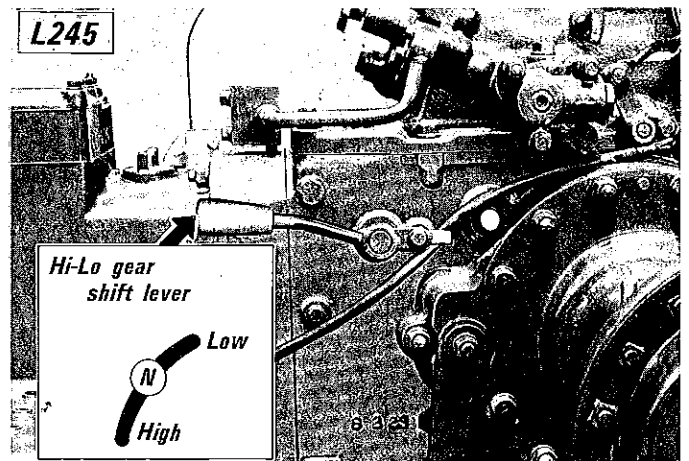
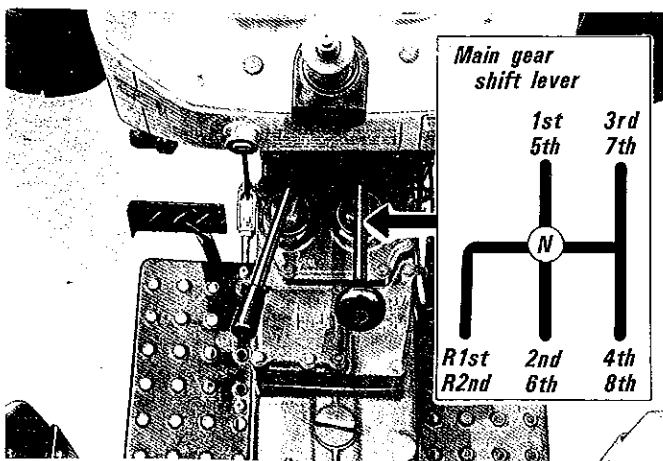

### [CAUTION]

To change speed, press the clutch pedal completely down and stop the tractor before attempting to proceed with speed change.

### ■ Front Wheel Drive Lever (L245DT)

Pull the front wheel drive lever back to engage the front wheel drive mechanism.

During ordinary farming work, keep the lever forward to leave the mechanism disengaged. The front wheel drive mechanism is very effective on the following jobs.

- (1) On slopes and in wet fields, or when connected to the Trailer or the Front-End-Loader where great traction is required.
- (2) On sandy land.
- (3) To prevent the tractor being thrust forward during rotary tilling hard soil.
- (4) Entering a job location or going over a high bank.

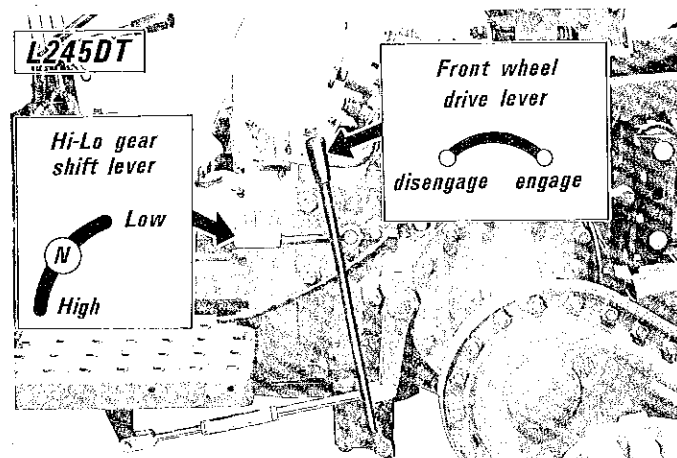

### ■ PTO Gear Shift Lever

Three PTO speeds can be obtained by shifting the PTO speed lever from the operator's seat.

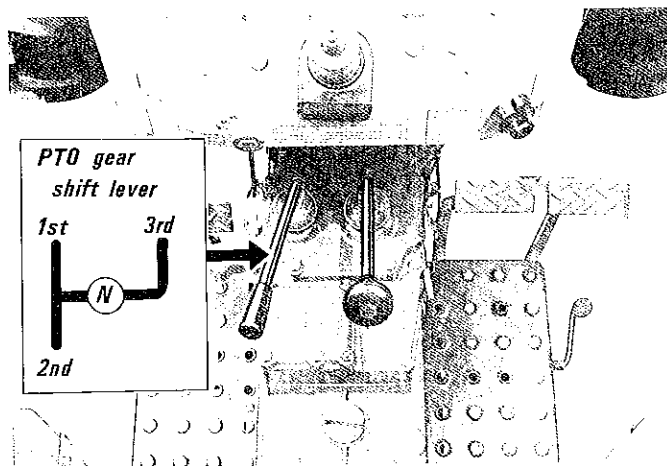

### ■ Hand Throttle

When the throttle is pulled, the speed of the engine is increased. When pushed forward, the speed is decreased.

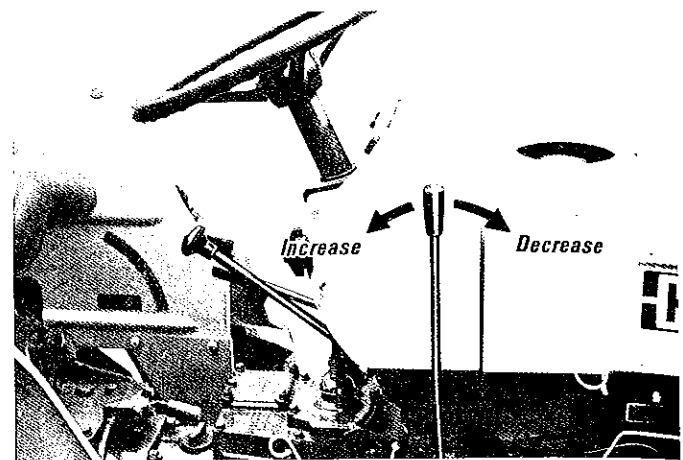

### ■ Foot Throttle

The foot throttle is interlocked with the hand throttle. Therefore, if the hand throttle is pushed forward fully, it would be possible to regulate the speed of the engine freely just by the amount the foot throttle is depressed. If the hand throttle is pushed up only half-way, even if the foot is released from the foot throttle, the speed of the engine would be decreased only to the position of the hand throttle.

### ■ Clutch Pedal

When the clutch pedal is fully depressed the clutch is disengaged. Shift the main gear shift lever to the desired speed and gradually release the clutch pedal, then the clutch would become engaged. The clutch should be disengaged by stepping on the pedal quickly, and engaged by slowly releasing the foot from the pedal so as not to damage the clutch plate.

### ■ Brake Pedal

The right and left brakes are independent of each other so there are two brake pedals. When operating the tractor on roads, always be sure to interlock the left and the right brake pedals. Do not forget to observe this precaution, otherwise, stepping on only one brake while operating on roads would cause unforeseen accidents.

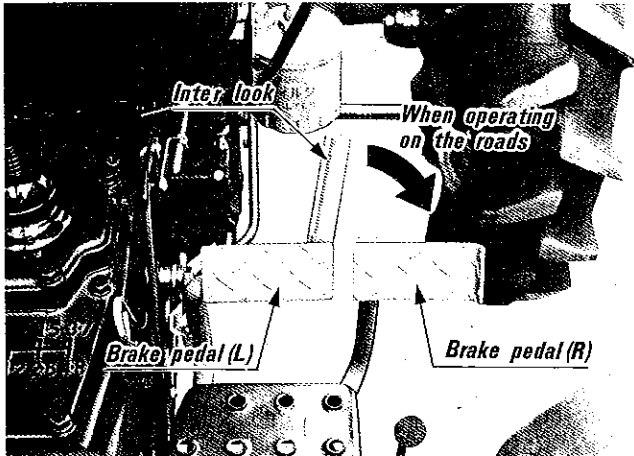

### ■ Parking Brake Lever

Interlock the left and the right brake pedals, step on the brake pedals, and pull the parking brake lever, which will hook the parking brake latch into the groove. This will keep the wheels locked, then remove the foot from the brake pedal.

### ■ Engine Stop Lever

When the throttle is pushed fully forward and the foot removed from the foot accelerator, the engine will continue to turn at slow speed. If the engine stop lever is pulled, the engine will stop.

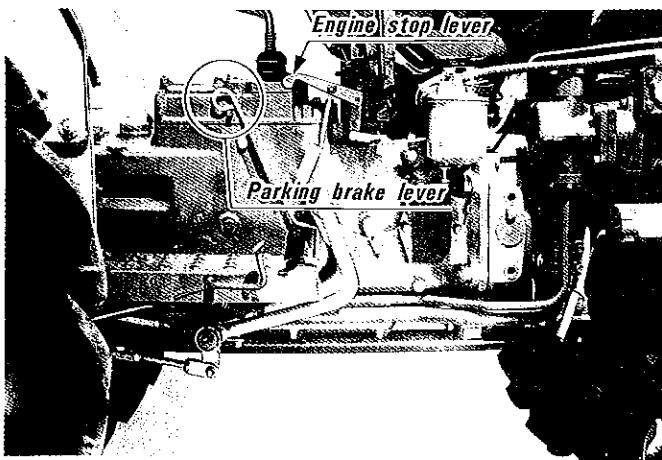

### ■ Differential Lock Pedal

The differential lock pedal is used when one of the rear wheels slips. When the pedal is depressed, the differential is locked. When released, the differential is released.

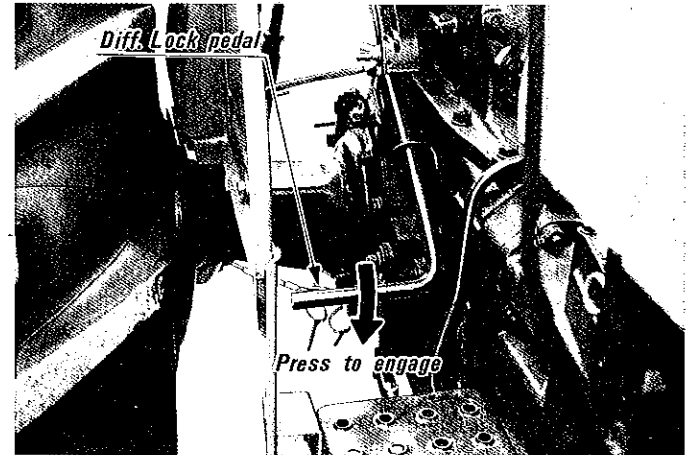

### ■ Seat & Parallelogram Seat Suspension

The seat has been especially designed so that it can be adjusted three stages, forward or backward, to fit the physique of the operator.

Furthermore, the seat can be tipped forward so that there would be no fear of the seat getting wet in the rain.

The parallelogram seat suspension must be comfortable and make your work fatigueless.

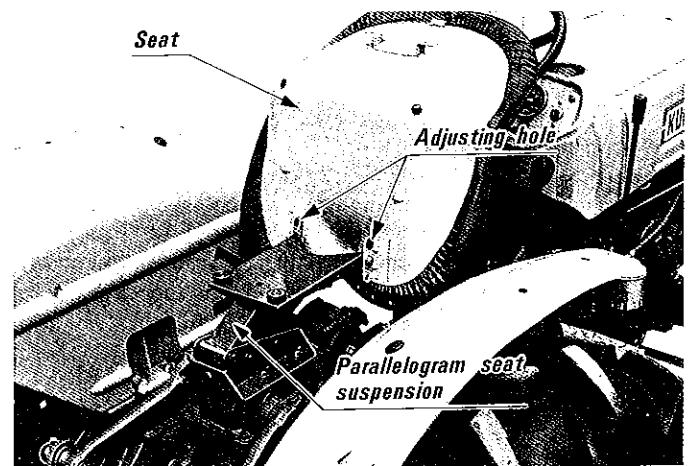

# 5 Operation

Your KUBOTA TRACTOR was designed and engineered for dependable performance during long service life. Follow the suggestions in this section of the Operator's Manual to help you obtain all the performance that was designed and built in your tractor.

As you become familiar with the operation of your new tractor, you will find it a flexible and reliable machine, designed and built with regular maintenance, will ensure maximum tractor life, economical operation and excellent performance.

## 5.1 PRESTARTING INSPECTION

Before starting the engine each day, perform the following checks and services:

- \* Do not start the engine in a closed storehouse, garage or room. Exhaust gas is poisonous. Be sure to open the doors and windows before starting.
- \* Check fuel supply.  
Use No.2 diesel fuel only.

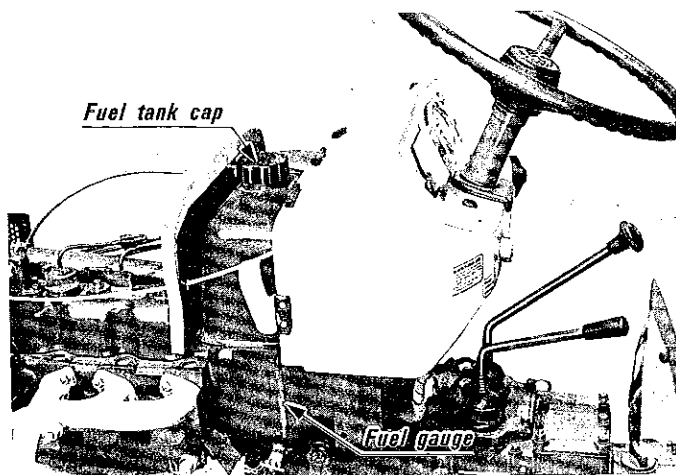

Fill the fuel tank before it becomes empty. If a diesel system is allowed to run out of fuel, it will become necessary to air-bleed the system after filling the fuel tank.

- \* Check oil level in the engine crankcase and correct, if necessary.

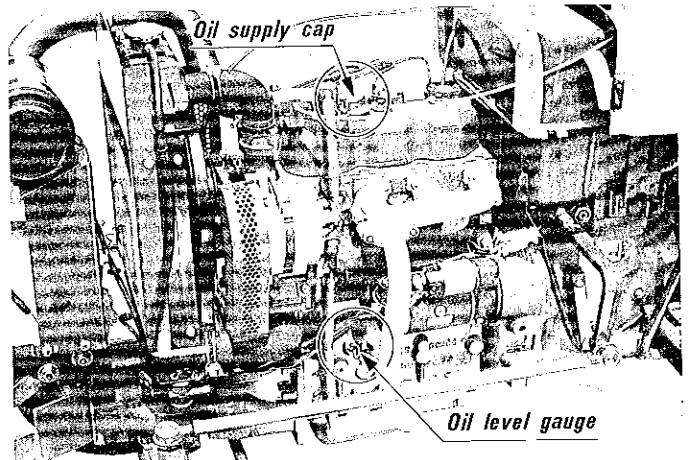

- \* Check the radiator coolant level and correct, if necessary. If operating in freezing temperatures, add anti-freeze. Proper level is indicated in figure below.

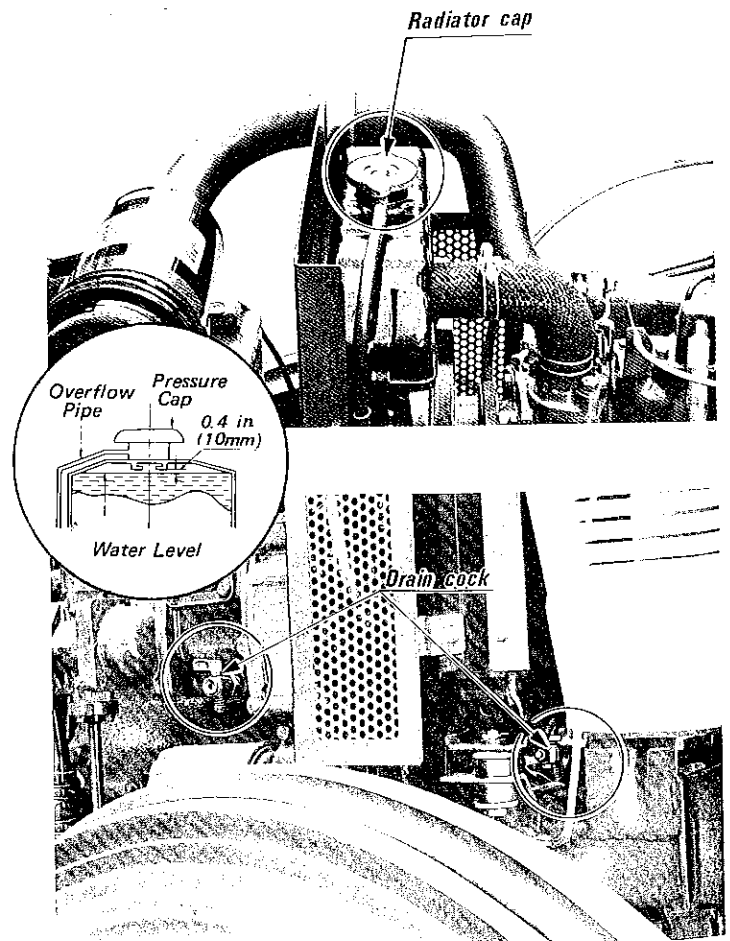

- \* Be sure air cleaner is free of obstructions and excessive dirt.  
Clean as instructed on "Maintenance and Checks".

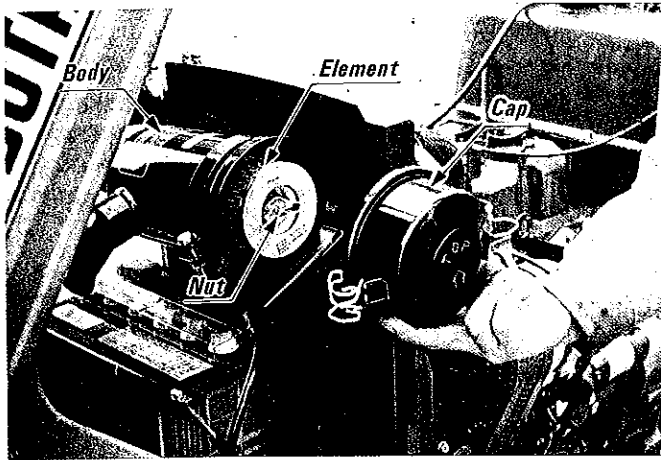

- Are all the grease nipples filled with sufficient chassis grease?

The front axle, tie rod, brake and clutch pedals, etc. are provided with grease nipples. (For the detailed points, refer to the "Lubrication Chart".)

For filling, wipe the nipple clean so that no dirt and dust may enter the grease.

- Check inflation pressure in tires.

Also inspect if the tires are not too worn or otherwise damaged.

- Check the brakes

If the brake should function only on one side when both the right and the left brake pedals are depressed, adjust the length of the brake rod of the inactive brake using the turn-buckle in the rod.

- Check the lights

Do they light up? Are they clean?

## 5.2 STARTING THE ENGINE

After all checks are completed, check once more to see nothing has been forgotten.

- a. Firmly lock the parking brake.
- b. Place the main gear shift lever and PTO gear shift lever in Neutral.
- c. Place hydraulic control lever in lowest position.
- d. Pull the hand throttle or push down the foot throttle a little.

- When the engine is warm

- (1) Depress the clutch pedal fully.

### [Note]

This is a safety feature. The engine will not start unless the pedal is depressed.

- (2) Turn the starter switch clockwise to start engine.

### [CAUTIONS]

- \* If the starter switch is turned to the right and the engine does not catch within about 10 seconds, wait about 30 seconds and repeat the above procedures. If the switch is used for over 30 seconds or is continuously used without any rest, it will cause starter damage.
- \* Important, it should be added that the starter switch should not be switched on when the engine is running.
- \* Use of the decompression knob for starting should be only when the battery seems to be discharged and starting is difficult.
- \* Never at any time use the decompression device to shut down the engine except in case of run away engine.
- \* If the oil pressure lamp or the battery charge lamp does not go off after the engine starts and runs at a specified speed, there is something wrong with the lubricating system or the battery charging system.
- \* Always allow engine to warm up before applying a load.

- Starting in cold weather

Perform procedure 1 for starting when the engine is warm as explained above and then.

- (3) Turn the starter switch counterclockwise for about 40 seconds or about 60 seconds in severe cold weather. (After about 10 seconds the glow plug indicator will glow)
- (4) Turn the starter switch clockwise to start engine.

- When the battery is weak or starting in extremely cold weather

Proceed in order 1 to 3, then,

- (5) Pull the decompression knob to release compression.
- (6) Turn the starter switch clockwise.
- (7) After 3—5 seconds, when the engine has gained momentum.
- (8) Release decompression knob.

## 5.3 STOPPING THE ENGINE

Reduce engine r.p.m. and apply even foot pressure on both brake pedals. Depress the clutch pedal and place main gear shift lever and PTO gear shift lever in Neutral. Lower equipment. Allow engine to idle for a short time before turning it off.

Stopping a hot engine at high speed may cause internal engine damage.

Set parking brake by pulling the rod. Pull the engine stop lever and turn main switch key counterclockwise to the "OFF" position to open electric circuit.

### [IMPORTANT]

Remove the key each time you leave the tractor. Then you are certain the ignition and lights are off. Also, it prevents unauthorized operators from starting the tractor.

### [CAUTIONS]

- \* After operating the tractor or engine, never touch the heat shield or muffler until it has had sufficient time to cool.
- \* Do not pull the decompression knob while the engine is running fast.

## 5.4 OPERATING THE TRACTOR

### ■ Pre-operation Inspection

Before starting, make a routine inspection of the tractor as outlined in the maintenance check-list.

Always allow engine to warm up before applying load.

### ■ Selecting travel speed

Depress clutch pedal, and shift the main gear shift lever and the hi-lo gear shift lever to the desired speed.

### ■ Release parking brake

Depress brake pedals all the way, and the parking brake releases.

### ■ Adjusting throttle position

Always operate power-driven equipment such as rotary mower, snow thrower, rotary tiller, etc., at full engine rpm unless otherwise specified in the equipment operator's manual.

Use gear shift lever to select a safe travel speed.

Proper travel speed will depend first on the type of equipment used on the tractor and second, on field, garden or yard conditions.

- Refer to your equipment operator's manual for more specific travel speed and PTO speed information.

### [CAUTIONS]

- \* Once the tractor has started to move, be sure to remove your foot from the clutch pedal.
- \* When descending steep slopes, engage the gear and descend with the clutch engaged.
- \* Always be sure to interlock two brake pedals when operating the tractor on roads.

## 5.5 STOPPING THE TRACTOR

- (1) Reduce engine speed by pushing throttle forward removing your foot from the foot throttle.
- (2) Disengage PTO and Main shift gears by moving levers neutral.
- (3) Lower attachment to ground.
- (4) Stop engine and remove switch key.

## 5.6 PARKING

- (1) After the tractor stops, check to interlock the right and the left brake pedals.
- (2) Set the parking brake by pulling the rod and depress pedals until it is set.
- (3) Return the main gear shift lever and the 'hi-lo' gear shift lever to neutral.

### [CAUTIONS]

Be sure to use the parking brake when parking on a slope for safety.

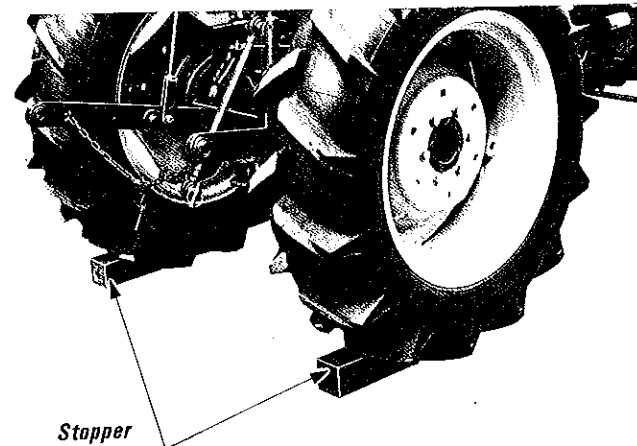



## 5.7 TURNING

When turning on curves, be sure to reduce the speed, then turn the steering wheel.

### [CAUTIONS]

The individual rear wheel braking on this tractor permits tighter turns and increased traction under slippery conditions. Sudden application of one brake at higher speed or while making fast turns could cause the tractor to tip over.

## 5.8 CHECK WHILE OPERATING

While operating the tractor, pay attention to see if the tractor is operating in the normal condition.

If you have see some troubles, stop the tractor and engine. Then check for trouble.

### ■ Temperature

When you hear the whistle mounted on the radiator, it is necessary to make following checks.

- (1) Check the level of the water in the radiator. If low, refill. Also check to see if there is any leakage.

### [CAUTION]

\* For details concerning supply of water to the radiator, read section on the radiator on Page 9.

- (2) Check to see if dirt, dust, etc. are not stuck to the radiator grill and the radiator fin and tubes. If necessary, clean well.
- (3) Check the fan belt to see if it is loosened. If loosened, tighten as explained in the section "Tension of the fan belt".
- (4) Check to see if furs have formed in the radiator piping. If necessary, clean.

### ■ Battery Charge Lamp

When the battery is discharging, the lamp lights up.

If the lamp should light up, stop the engine and make following checks.

- \* Wiring failure.
- \* Connector failure of Dynamo and Regulator.

### ■ Oil pressure lamp

The oil lamp is extinguished while the engine is running. For a while after the engine is stopped until the pressure in the lubricating system drops, the oil lamp will remain extinguished. If the lamp should light up during operation, it indicates lack of oil or trouble in the lubricating system. (The oil lamp is lighted up at a pressure under 21.3psi) (1.5kgf/cm<sup>2</sup>: 0.17MPa). However, there is no trouble if the lamp should light up when the engine is running at slow speed.

### ■ Fuel Tank

Always consider the amount of work to be done so that the fuel tank would not become empty. If the fuel tank should become empty, air would enter the fuel system.

### ■ Color of exhaust gas

When the tractor is used within the limits of the rated output, the exhaust gas will be colorless. If used at outputs over the rated output, exhaust gas may become a little colored, but the output will not drop. But if the tractor should be operated with continuous dark exhaust gas, it may become the cause of trouble, so check the working condition and operate the tractor so that it will not be overloaded.

## 5.9 OPERATING ON PUBLIC ROADS

- (1) Make sure the left and right brake pedals are interlocked before attempting to operate on public roads.
- (2) Do not rest your foot on the clutch pedal while operating on public roads.
- (3) On public roads, only the driver is allowed to ride on the tractor.
- (4) Pay close attention to the condition of the roadside (shoulders) on public roads. There have been cases of roadside collapse due to the weight of the tractor. Special caution must be taken on rainy days.
- (5) Be sure to reduce engine speed, or, if necessary, change to "low" speed range when turning the tractor on sharp curves.
- (6) Use engine to brake when descending steep slopes.
- (7) While operating on public roads, obey all safety regulations and allow automobiles travelling faster to pass. Do not block the road.

## 5.10 OPERATION ON SLOPES

### ■ Engine braking

When the tractor is on a downhill slope, push the throttle forward and remove the foot from the foot throttle. Then the engine speed will drop, which will brake the tractor. When traveling the tractor down on a slope, never depress the clutch pedal but use the engine brake to travel down. If necessary to further reduce the tractor speed, depress the brake pedal lightly.

### [CAUTIONS]

It is dangerous to travel down a slope by just depressing the brake pedals while disengaging the clutch.

## 5.11 HANDLING THE TRACTOR ON THE FARM

### ■ Operation on Farm Roads

- (1) Stop operation of any attached farming implement while driving on farm roads.
- (2) The front wheels of the tractor tend to lift when farm implements are attached to the rear of the tractor.
- (3) When it is necessary to attach a large-sized or extra-heavy implement to the rear of the tractor, contact your dealer for selection of an appropriate counterweight for the front and slow down.
- (4) While driving the tractor on farm roads, keep in mind safe driving practices.

### [Note]

For maximum safety always pay close attention to the balance between the front and rear wheels of the tractor.

### ■ Operation in the Field

- (1) For field work, disconnect the brake pedal interlock so that the right and left brakes can be engaged separately.
- (2) Be careful not to force sudden loads while operating and implement from the power-take-off since such loads tend to shorten engine life. Always lower implements slowly.
- (3) While pulling or towing, be sure to use the hitch. Do not use the top-link fixing plate since this may cause the tractor to tip over.

## 5.12 USE OF THE DIFFERENTIAL LOCK

### When to use the Differential Lock

- (1) Engage the differential lock if driving wheel slips on one side and no traction is obtained when descending or climbing in the field.
- (2) Engage differential lock when driving wheel is caught in mud and cannot provide sufficient traction.
- (3) If traction difficulties are encountered while plowing, engage the differential lock.

### [PRECAUTIONS]

- (1) Always reduce engine speed when engaging the differential lock.
- (2) Never turn the tractor when differential lock is engaged. It is dangerous and can also cause damage to tractor mechanism.
- (3) By releasing the lock pedal, the differential lock is automatically disengaged. If the differential lock does not disengage easily, push the right or left brake pedals lightly in a moment.

# 6 Hydraulic System

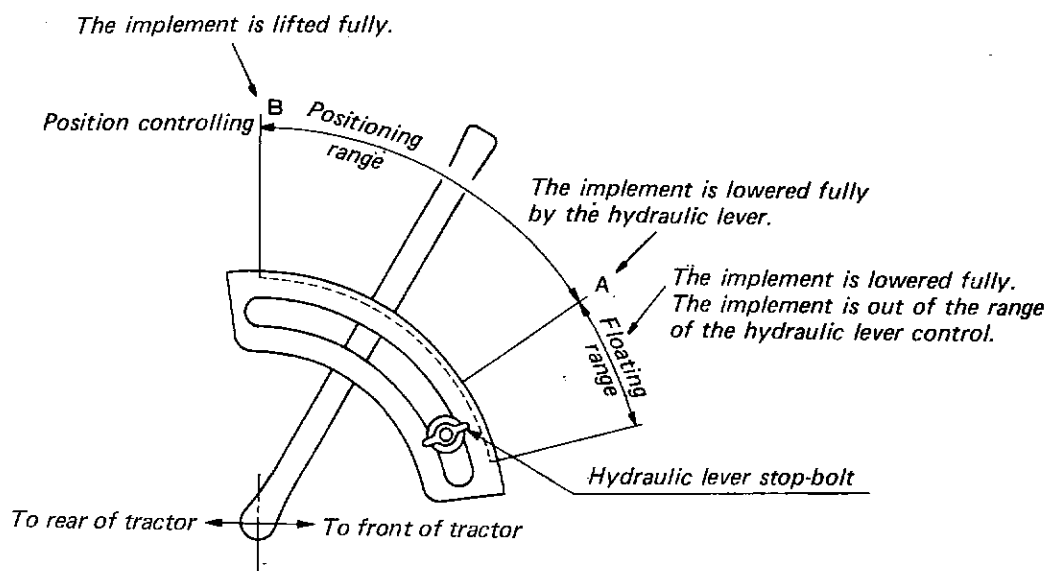

	Position of hydraulic lever	Position of implement
Position controlling Positioning range	Toward A	Lowered
	Toward B	Raised
Floating range	Below A	Implement lowered but out of control range

## Hydraulic System

- Implements such as rotary mower, rear mounted equipments are raised and lowered hydraulically with the hydraulic control levers.  
To lower equipment, push the lever forward, to raise equipment, pull the lever back.
- The system has an position control device. Set the stopper to the position you desire raising height of implement, thereafter raise the lever, then implement stops.

### [PRECAUTIONS]

- Do not operate until the engine is well warmed up. If operation is attempted while the engine is still cold, the hydraulic mechanism will not fully function and its service life will be shortened.
- If noises are heard when the implement is lifting after the hydraulic control lever has been thrown, the hydraulic mechanism is not adjusted properly. Unless corrected the unit will be damaged. Contact your Kubota dealer for adjustment.

## Position Control Notes

- The position of the implement can be adjusted freely with the oil pressure control lever when the position of the implement is within a certain range.
- The implement is lowered fully when the lever is moved to the floating range.

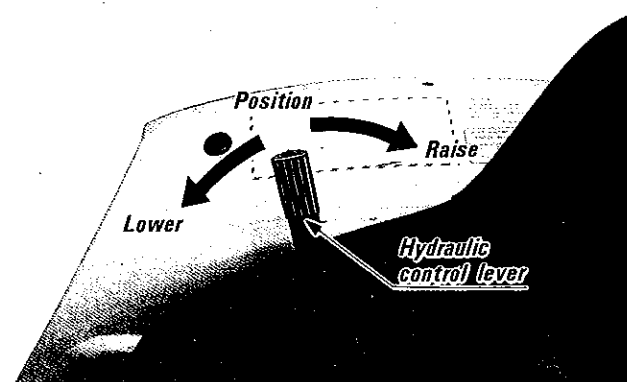

### ■ Adjustment of Lever Stopper

- (1) Prior to operation, adjust the position of the hydraulic lever by fixing the stopper at the point when the implement is positioned at the desired elevation.
- (2) While operating the tractor, the desired position of the implement can then be obtained by simply moving the hydraulic lever to the point where it will be stopped by the stop bolt.
- (3) When it is necessary to lift or lower the implement to one of its extreme positions, push the lever inward and adjust it to its desired position.

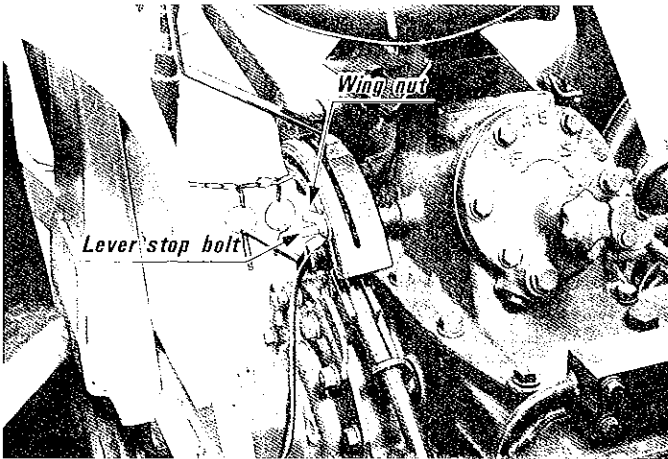

### ■ Adjustment of down speed

Adjust down speed of implement by turning the grip under the seat.

It depends on weight of implement and operating speed.

Adjust grips clockwise for down slow, counter clockwise for down fast.



### ■ Safety Precautions during Implement Adjustment

- (1) Stop the engine completely and lock the hydraulic system when changing rotary tiller blades, fixing bolts or removal of weeds or straw or other maintenance or checks.
- (2) When locking the hydraulic mechanism do not tighten the screw excessively.

# 7 Three-Point Hitch

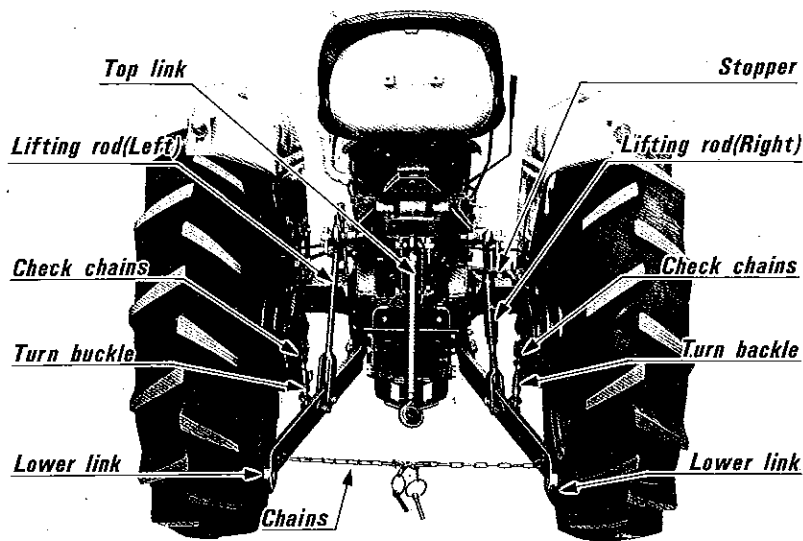

### ■ Adjustment of Top Link

- (1) Adjust the angle of the implement to the desired position by moving the top link.
- (2) The fixing position of the top-hitch varies according to the type of implement being used.

### ■ Adjustment of Lifting Rod

- (1) Adjust the position of the implement evenly by moving the lifting rod lever.
- (2) After the adjustment is completed, secure with the stopper.
- (3) Correct positioning of the lifting rod to the lower link is shown below. Positioning varies according to the type of implement being used.

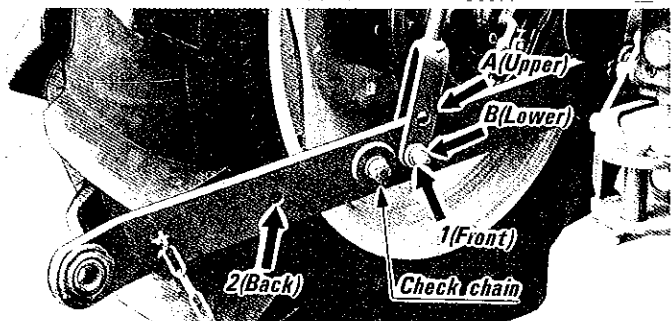
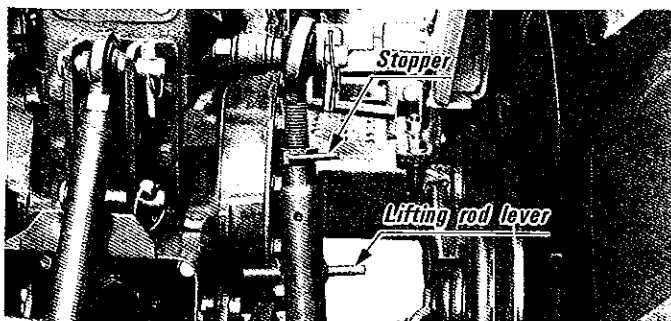

Lifting rod hole	Lower link hole	Implement
B	1	FS1020, FS1270 Rotary tiller
A or B	1	Three-point hitch implement

### ■ Adjustment of Check Chains

Adjust the turn-buckle to control horizontal vibration of the farming implement.

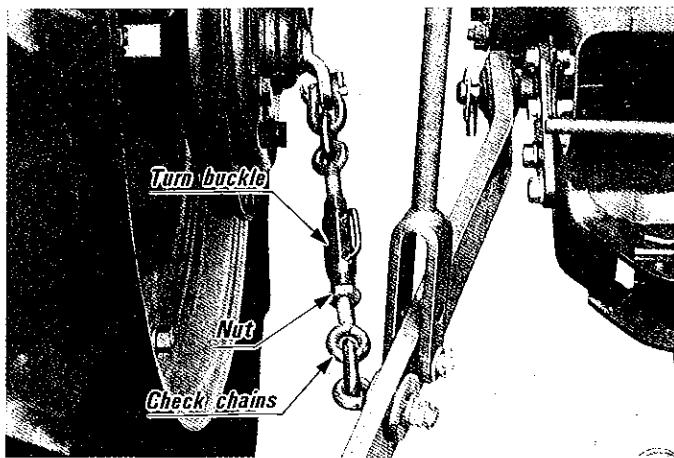

Type of implement	Chain adjustment
Plow, furrower, sub-soiler, cultivator, ditcher	Loosen until the implement can be moved 1/5 inch (5~6cm) horizontally.
Rotary, mower, hay rake, tedder, ridger	Tighten

# 8 Storage

When the tractor is not to be used for more than 2 or 3 months, clean the outside of the tractor well and take the following procedures for storage.

- \* Drain out the water from the radiator  
Open the drain cocks on the right side of the engine and the bottom of the radiator and remove the radiator cap to drain out all the water. Leave the drain cocks open. Hang a sign saying "NO WATER" on the radiator cap.  
During severe cold weather when air temperature falls below 32°F (0°C), freezing point, there are fears of the engine being damaged by freezing, so be sure to drain out all the water.
- \* Be sure to stop the engine by pulling the engine stopping lever.  
If the engine was stopped by pulling the decompression knob to release compression, and left as it is, it might become difficult to start the engine next time, or may become the cause of other troubles.
- \* Drain out the dirty engine oil. If necessary, exchange the oil filter with new one. Then, wipe the inside of the crankcase clean. Fill new oil and run the engine for about five minutes so that the new oil would penetrate to the various parts.
- \* If the air cleaner should be extremely dirty, clean it.
- \* To decrease the weight on the tires, and to protect the tires from moisture of the ground, set blocks underneath the axle, or put wooden boards underneath the tires. The inflation pressure in the tires should be a little more than the specific pressure.
- \* Grease or engine oil should be applied to the parts which are apt to become corroded.
- \* Check the bolts and the nuts of the various parts for loosening and tighten if loose.
- \* Remove the additional weights if mounted.
- \* The wooden spacer among the accessories should be set to the clutch pedal so that the clutch would be completely disengaged.
- \* Lower the implement to the ground. Do not leave it hanging.
- \* Select dry places where things would not become wet with rain for the storage. Keep the tractor covered with canvas sheets.
- \* Remove the battery from the tractor, recharge and adjust the amount of the electrolyte to the proper amount. Keep the battery in dry and shady places.

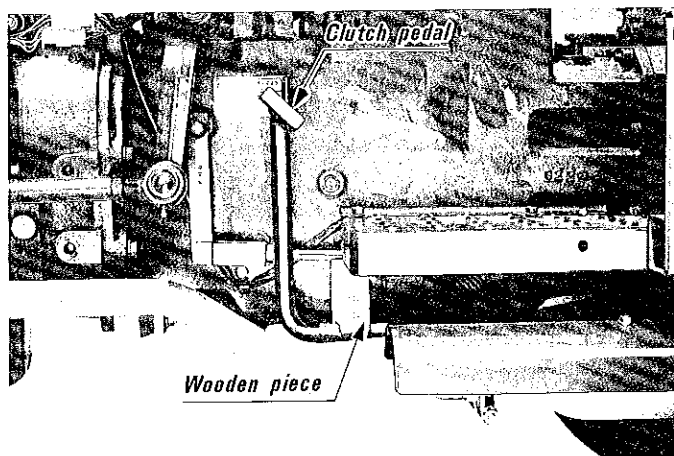

# 9 Maintenance and Checks

For periodic service, refer to "LUBRICATION AND PERIODIC SERVICE CHART" added to this manual.

## 9.1 ENGINE LUBRICATION

### ■ Crankcase lubrication

After the first 35 hours of operation of a new tractor and each 75 hours thereafter, exchange oil.

Oil used in the engine should have an American Petroleum Institute (API)/SAE classification of Service DS (CD).

It is easier to exchange oil while the engine is warm.

Depending on prevailing air temperature, use oil of viscosity shown in the following chart.

Air Temperature	Oil Viscosity
Above 77°F (25°C)	SAE 30
Between 32° ~ 77°F (0° ~ 25°C)	SAE 20
Below 32°F (0°C)	SAE 10W, 10W-30

When the oil has to be changed to that of a different brand or of a different viscosity, the inside of the crank case should be washed and cleaned in the manner explained below and filled with new engine oil, even if the number of hours the present engine oil has been used, does not reach the hours stated above.

- (1) Rinse off the dirt and other foreign matters on the screen in diesel fuel or kerosene. Wipe off the metal grit clinging to the magnet on the tip of the oil filter.
- (2) Fix the oil filter into the crank case. The screw should be screwed in the full length of the thread.
- (3) Pour in new engine oil until it rises to the upper notch of the oil level gage.

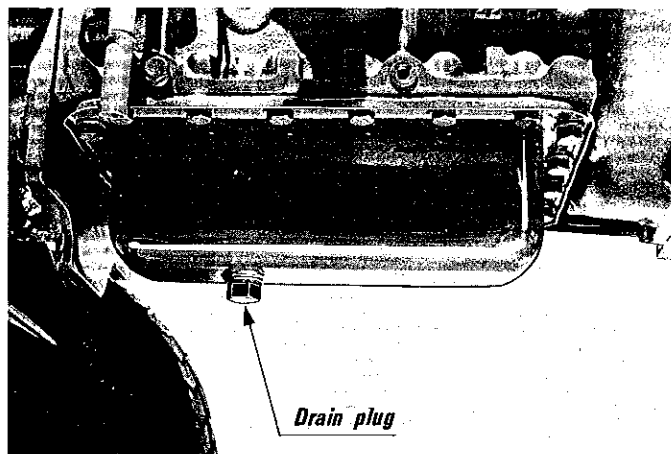
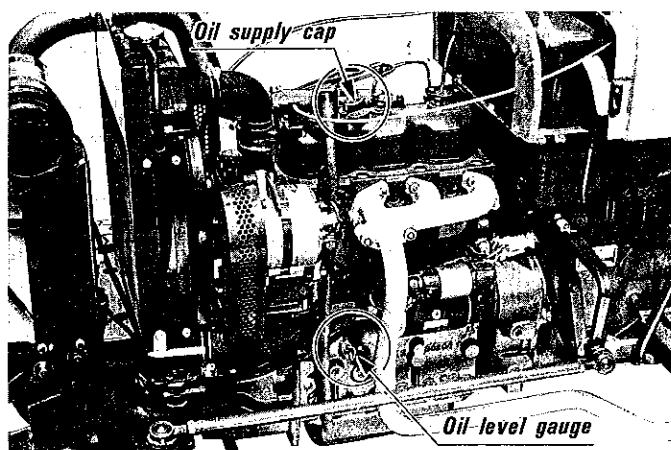

- \* When the engine oil is specially dirty.  
Clean the oil filter (2). Be careful at the time of disassembly so as not to damage the relief valve, regulating valve, etc. Wash well and reassemble correctly as before.  
After reassembly and starting of the engine, the oil level will drop by the amount of the oil which enters the oil filter (2). Therefore, start the engine once so that oil will penetrate to the various parts and check to see if there is nothing abnormal in the oil pressure. (The oil lamp will go off.) Then stop the engine and supply engine oil which is short. Then restart for operation.

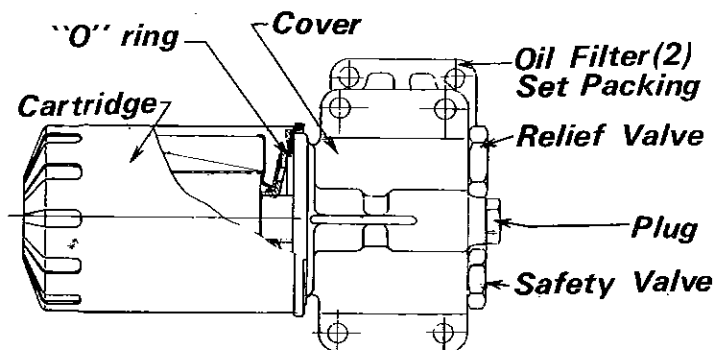
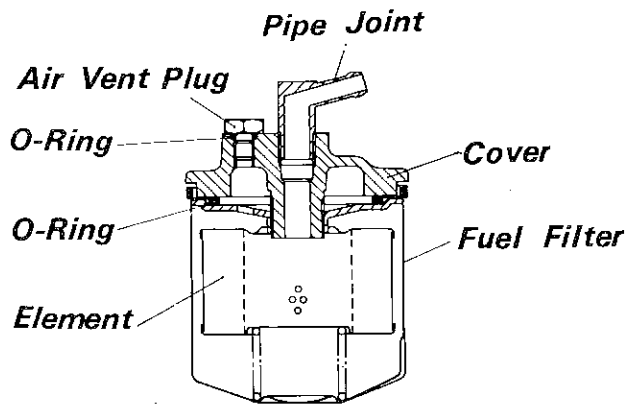
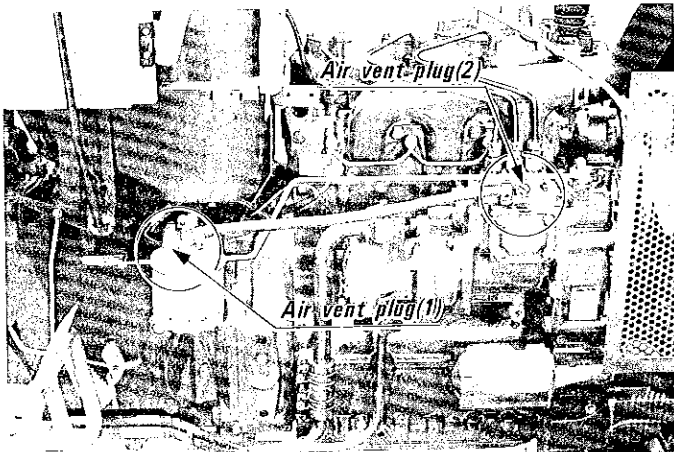

Diagram of structure of Oil Filter (2)

### ■ Fuel Tank

\* Air venting in the fuel system is as follows.

- (1) Fill the fuel tank with fuel and open the fuel cock.  
(Use only No.2 diesel fuel.) (5.8 Gallons: 22ℓ)
- (2) Loosen the air vent plug (1) of the fuel filter two or three turns using a wrench.
- (3) When there are no more air bubbles in the fuel which flows out, tighten as before.
- (4) Loosen the air vent plug (2) of the injection pump and vent air in the same way.



**Structure of Fuel Filter**

When the air venting is finished, fuel which do not contain air bubbles will be filtered by the fuel filter and sent to the fuel injection pump. Fill the fuel tank before it becomes empty. If a diesel system is allowed to run out of fuel, it will become necessary to air-bleed the system after filling the fuel tank.

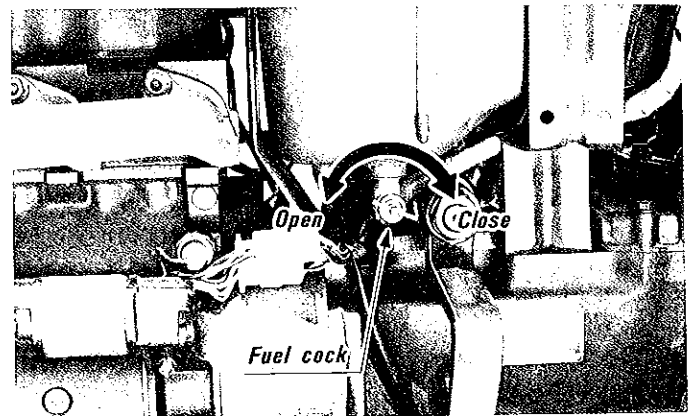
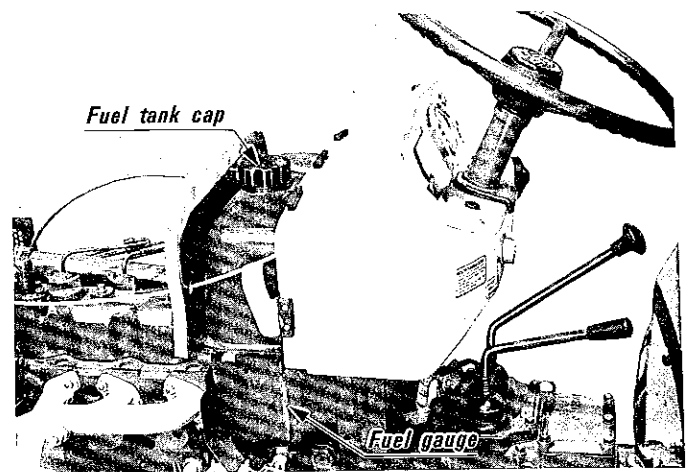

### ■ Checking Fuel Pipes

Check that fuel pipe clamps are sufficiently tightened after every 150 hours of operation, or every 6 months, whichever comes first.

- (1) If pipe clamps are loosened, apply oil and retighten to desired tolerance.
- (2) The fuel pipe is made from rubber and will require periodic replacement.  
Change at least once every two years. When changing pipe also replace clamps.
- (3) Air-bleed the system after changing.



## 9.2 AIR CLEANER

1. This air cleaner of dry element type, therefore oil is not needed.
2. Empty dust cup.  
Dust level should not be allowed to build up to more than half from bottom in dust cup baffle.  
Remove foreign material such as leaves from around the filter and tighten wing bolt if necessary.
3. Install the dust cup to the air cleaner so as the mark on the cover of the cup points upward.
4. Clean the element every 100 hours of operation. Direct dry, clean air up and down pleats on the clean air side of the filter.

### [CAUTION]

\* Air pressure at the nozzle must not exceed 100psi (7kgf/cm<sup>2</sup>: 0.69MPa). Maintain reasonable distance between the nozzle and the filter.

To wash the filter use KUBOTA Filter of Donaldson ND-1500 Filter Cleaner which is especially effective on oily and soot-laden filters.

To use: Dissolve KUBOTA Filter Cleaner in a concentrated solution of cold water. When granules are thoroughly mixed. Add water to make a solution equivalent to 2 oz. KUBOTA Filter Cleaner for each 1 gallon of water. (15gf KUBOTA Filter Cleaner for each 1 Quart (1ℓ) of water.) Allow element to soak 15 minutes. Then agitate element to dislodge loosened dust—rinse in clear water—allow element to dry.

5. Filter should be replaced after 6 cleanings or annually.

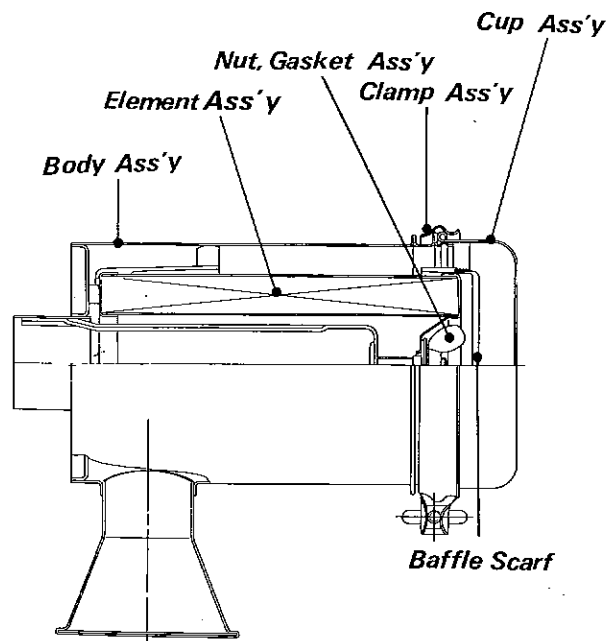

Structure of Air Cleaner

### [CAUTIONS]

Never run engine with filter element removed.

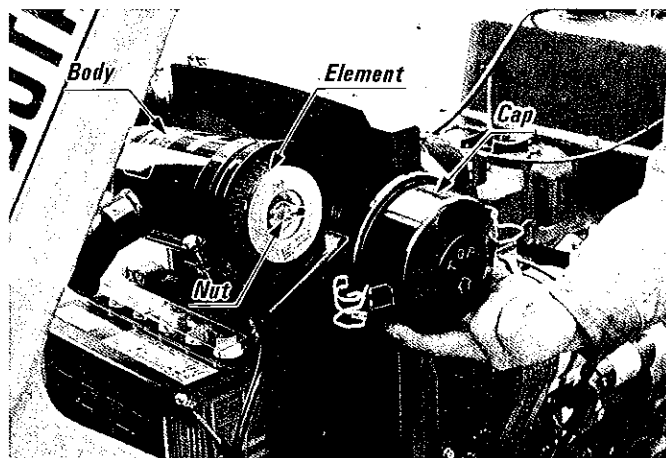

## 9.3 RADIATOR

The radiator has been constructed rigidly but if handling is mistaken, the radiator may be damaged and the engine may be damaged because of it. If the radiator is filled with clean water before start of work, it would be ample for one day's work. (Make it a habit to check the water level every day before start of work.)

### ■ The pressurized Radiator Cap

- (1) Be sure to close the radiator cap securely.  
The radiator cap completely seals in the water.  
If the cap is loose or not properly sealed, the water would spill out and soon cause a shortage of water.
- (2) Do not open the radiator cap while the engine is running under heavy load or immediately after the engine has been stopped. If the cap should be opened in such cases, hot water would gush out and cause scalding. Make it a habit to wait for about 10 minutes before opening the cap.
- (3) When draining water from the radiator, open the water drain cocks (at the bottom of the radiator and the side of the cylinder frame) and at the same time remove the radiator cap. If the drain cocks are opened with the radiator cap closed, only a part of the water would be discharged and it would be impossible to drain out the water cooling system completely.

#### ■ Clean the radiator net

When the tractor is used in wet fields, grass seeds may get caught, or mud may splash onto the radiator net. Also when used at night, insects may become caught on the net. In such cases remove the net and clean it well.

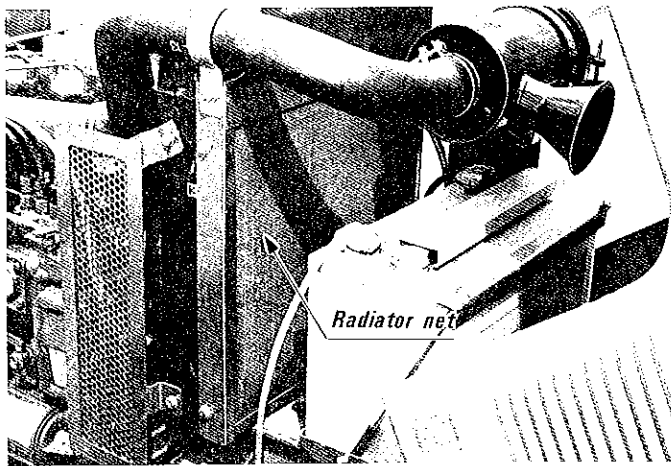

#### ■ Radiator Cement

As the radiator is of sturdy and rugged construction, there is practically no fear of water leakage, but if there should be water leakage, it can be easily stopped by using Kubota Radiator Cement.

However, if the leakage should be severe, consult the dealer in your district.

#### ■ Radiator Fur Inhibitor

If furs form in the water cooling system, the efficiency of the radiator would be greatly decreased. Furs form, of course, when hard water used, but it would also form if tap water is used. Therefore, use Kubota Fur Inhibitor No.11 in the water to clean furs. It would be effective for one month, so change the water once a month.

#### ■ Use of anti-Freeze

When the water freezes, there are fears that the cylinder and the radiator would be damaged. In winter, when the temperature drops below 32°F (0°C), drain out the water after the tractor has been used, or use anti-freeze. There are two types of anti-freeze, permanent type (PT type) and semi-permanent type (SPT type). In the Kubota engine, always be sure to use the permanent type (PT type).

##### (1) Washing of the cooling system

When the anti-freeze is to be used for the first time, pour clean water into the radiator and then drain. Repeat 2 or 3 times so as to clean the inside of the radiator.

##### (2) The mixture of the anti-freeze varies with the temperature, so please be very careful of the ratio to be used. Also, the mixture varies a little depending upon the manufacturer. Therefore, ask the store for the instructions as to the amount and the method of use. The effective

capacity of the water in the radiator is 7.0 Quarts (6.6ℓ).

- (3) Pouring anti-freeze well with the water. If the anti-freeze is to be used by pouring in without mixing, run the engine after pouring in the anti-freeze, so as to mix it well with the water.
- (4) Addition of anti-freeze  
If the cooling water decreased because of evaporation, just add water. If water has decreased because of leakage, make a mixture of water and anti-freeze in the same proportion as initially made and then add to the radiator.
- (5) Anti-freeze will absorb moisture, so be sure to keep the container well-covered after use.
- (6) Since anti-freeze contains anti-corrosive chemicals, it is not necessary to use Kubota Radiator Cleaning Agent No.11 when anti-freeze is used.

#### ■ Temperature

Checks when the water temperature is over 212°F (100°C)

- (1) Check to see if dirt, dust, etc. are caught in the radiator net or the radiator tube and fin.
- (2) Check to see if the fan belt has not become loosened and is taut.
- (3) Check to see if furs have formed in the pipes of the radiator.
- (4) Check to see if the thermostat is working properly. Remove the thermostat and dip it into hot water, and then check to see if it opens at the temperature marked on the thermostat. If the thermostat does not work properly, replace with new one.

#### ■ Cleaning the Radiator

Clean the water cooling system of the engine after every 500 hours of operation. Also, clean the inside of the radiator when mixing anti-freeze or when changing from water mixed with anti-freeze to only water.

#### ■ Checking Radiator Hose

Check that radiator hose clamps are sufficiently tightened after every 150 hours of operation, or every 6 months, whichever comes first.

- (1) If hose clamps are loose, apply oil and retighten to desired tolerance.
- (2) The radiator hose is made from rubber and will require periodic replacement. Change at least once every two years. When changing hose also replace clamps.

Parts	Code No.
Hose 1	15221-72851
Hose 4	15321-72941
Clamp	15108-72873

- (3) If radiator hose or clamps break during operation, boiling water may escape and cause injury. Be sure to check these items regularly and replace them at once if they appear damaged or worn.

## 9.4 BATTERY

### ■ Battery

Check battery once a month, making sure each electrolyte level is to the bottom of the filling tube.

If necessary, add distilled water.

Check it more often during hot weather.

### [CAUTION]

- \* Always check electrolyte level after charging battery. If necessary, add distilled water to maintain proper level.
- \* Check battery terminals to be sure they are clean and free from corrosion. Keeping the battery clean will give prolonged service. Remove corrosion from the terminals periodically and coat terminals with grease.

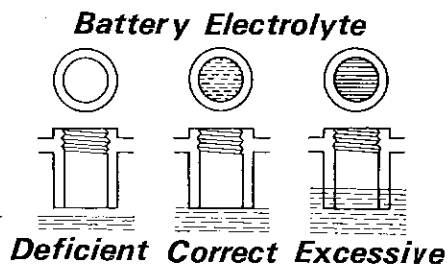

- \* Maintain the battery at full charge during the winter months to prevent freezing. When water is added during freezing weather, run the engine at least an hour to make sure water and electrolyte have mixed thoroughly.

### [CAUTION]

Protect against fire and explosion.  
During refueling never touch battery.

- \* This battery is a dry-charged type. Your dealer will fill electrolyte and charge for use for the first time.

For periodical maintenance, take care of the battery because the life of it would greatly depend on you.

- (1) When the battery becomes discharged, it would become difficult to start the engine and the lights would become dim. It would be too late if the battery should be discharged to such a condition. The battery should be charged before it becomes completely discharged.

- (2) In the battery, the water in the electrolyte would become evaporated or the electrolyte would decrease during the charging procedure.

When there is a shortage of the electrolyte, the battery would be damaged. If the electrolyte should be excessive, it would spill and damage the tractor.

- (3) Check to see if the electrode plate separator is exposed or not. If there should be a lack of electrolyte, be sure to add distilled water.
- (4) When charging the battery, connect the (+) of the battery to the (+) of the charger; and the (-) of the battery to the (-) of the charger and charge in the ordinary way.

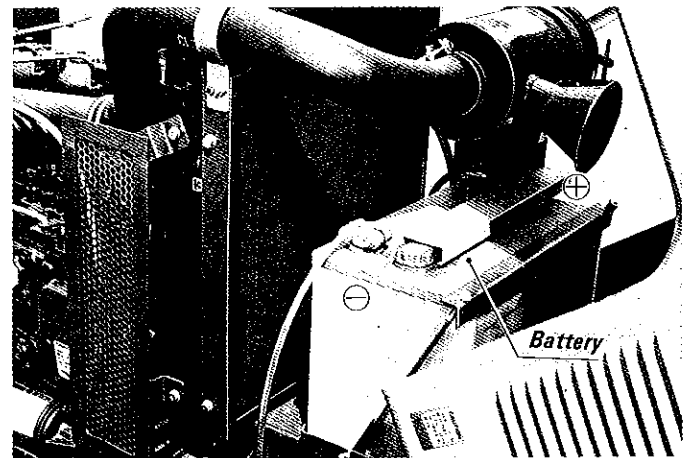

- (5) Rapid charging method is the way of charging the battery in a very short time with a large current when the battery is in the discharged condition. This method should be used only in cases of emergencies. It should be added here that if the engine should be started in this way, after the tractor work is finished and as soon as possible, the battery should be correctly charged in the manner explained in the instruction manual for the battery. If the battery is not charged in the correct way, the life of the battery would be extremely shortened:

### \* For long time storage

- (i) When the tractor is to be stored for a long period of time, remove the battery from the tractor, fill the electrolyte to the correct level and keep stored in a shady, dry place.
- (ii) The battery will discharge, even during storage, so charge the battery once a month during the summer and once in two months during the winter.

### ■ The First Operating Instruction for Battery

- (1) Screw off vent plugs and discard temporary sealing cardboards and tapes. The sealing cardboards and tapes should not be refitted after the batteries are filled with electrolyte.
- (2) Fill each cell with electrolyte having a specific gravity given in Table 1 up to a height of 3/8" (10mm) above upper edge of separators.

Table 1

	AIR TEMPERATURES	
	TEMPERATE Ordinarily below 90°F (32°C)	TROPICAL Frequently above 90°F (32°C)
sp.gr. of Electrolyte for Filling	1.260	1.240
sp.gr. of Electrolyte when fully charged	1.260 to 1.275	1.240 to 1.255

- (3) After standing 2 or 3 hours correct the electrolyte to former level.
- (4) Connect positive terminal (+) of battery, with positive terminal of D.C. charging unit, and negative terminal (-) with negative terminal.
- (5) Batteries are preferably charged by current showed in Table 2. Keep vent plugs removed during charging.

Table 2

TYPE	Volts (V)	Number of plate per cell	Capacity at 20 H.R (A.H)	Volume of Electrolyte (ℓ)	Normal Charging Rate (A)
N70Z	12	13	65	4.3	6.2

- (6) Check temperature of electrolyte, if they would reach 105°F (40°C) lower rate. When temperature too high, reduce charging rate and charge for a proportionately longer period.
- (7) This battery are then ready for use, it is preferable, however to give a freshing charge for several times showed in Table 3.

Table 3

Period of storage from manufactured (months)	freshing charge (times)
0 - 6	about 5 hours
6 - 12	10
over 12	30

- A battery is fully charged when the cell are all gassing freely and the specific gravity ceases to rise for three consecutive readings taken at an hour intervals. Specific gravity shall then be adjusted to showed in Table 1.
- (8) Check electrolyte level two hours after charging is finished and correct it if necessary by adding distilled water.

### ■ Operating Instruction

- (1) Battery must be fixed tightly in case or holder.
- (2) The battery should be secured and the connecting cables properly fitted and sufficiently long to prevent pulling the terminals on battery.
- (3) Keep vent plugs tight on the vent holes.
- (4) Keep battery and surrounding parts, particularly, the tops of the cells clean and dry.
- (5) Keep the terminals and the cables free from corrosion being coated with pure vaseling or grease.
- (6) The level of electrolyte should always be kept between the level lines.  
(At hard rubber container should be kept to a height 3/8" (10mm) above upper edge of separator.)  
Add approved water (preferably distilled water) regurally to each cell until this level will be reached. Never add acid.
- (7) Recharge battery periodically after 4 weeks when operation in irregular or battery is taken out of service, but only until all cells gas evenly and freely.  
Make sure to prevent overcharging.
- (8) Battery should be charged once each month when is service.

## ■ Trouble shooting

Condition of Battery	Probable Cause of Trouble	Measures	Precaution
Starter does not function	Battery over-used until light becomes dim	Charge for long period by ordinary charging method until specific gravity of 1.26 is reached.	Do not overuse the battery and charge before fully discharged. (Refrain from overdischarging)
	Charging of battery neglected		
	Defective Alternator rectifier.	Repair Alternator and replace defective rectifier. Charge battery well.	Check Alternator rectifier.
	Dirty or corroded terminal contacts Bad brushes, armature or field	Wash terminal with hot water and tighten well. Replace	Keep terminals clean, tighten well and grease to prevent corrosion.
	Life of battery expired	Replace battery	
From beginning, starter does not function, and lights become dim quickly.	Battery not charged well	Charge battery for long period by ordinary charging method.	Battery must be serviced properly before initial use.
Low electrolyte level.	Battery used with shortage of electrolyte.	Add distilled water and charge battery	Make routine checks of electrolyte
	Battery over-used. Moreover, charging was neglected. (Refrain from over-discharging.)	Charge for a long period.	Do not overuse the battery and fully discharge.
	Defective Alternator rectifier. Defective terminal contacts causing sulphation of electrodes.	Check Alternator and rectifier and charge for long period by ordinary charging method.	Make routine checks of terminals, to make sure they are clean and tight.
Battery cannot be charged.	The current of the Alternator during operation is too high causing plates to drop, warp or short-circuit.	Decrease the charging current of Alternator. Exchange defective battery.	Check charging current of Alternator.
	Life of battery expired.	Exchange battery.	
Corrosion of terminals severe and terminals heated.		Clean scale from terminals and tighten well.	Keep terminals clean and well tightened. Apply grease to prevent corrosion.
	Current of the Alternator during operation is too large.	Adjust charging current of Alternator.	Check charging current of Alternator.
Electrolyte decrease rapidly	Over heating due to over charging.	Check charging out put.	
	Storage battery cracked or has small holes.	Replace battery	Secure battery to tractor so it would not move.

## 9.5 DIAGNOSIS OF ENGINE TROUBLE

### ■ When engine is difficult to start

Cause	Countermeasures
Fuel is thick and doesn't flow	<ul style="list-style-type: none"> <li>* Check the fuel oil tank and fuel oil filter.</li> <li>* Remove water, dirt and other impurities</li> <li>* As all fuel oil will be filtered by the filter, if there should be water or other foreign matters on the filter, clean with kerosene.</li> </ul>
Air or water mixed in fuel system	<ul style="list-style-type: none"> <li>* If air is in the fuel filter or injection lines, the fuel pump will not work properly. To attain proper fuel injection pressure, check carefully for loosened fuel line coupling, loose cap nut, etc.</li> <li>* Loosen air vent screws atop fuel filter and fuel injection pump to eliminate all the air in the fuel-oil system.</li> </ul>
Thick carbon deposits on orifice of injection nozzle.	<ul style="list-style-type: none"> <li>* This is caused when water or dirt is mixed in the fuel. Clean the nozzle injection piece, being careful not to damage the orifice.</li> <li>* Check to see if nozzle is working properly or not. If not, install a new nozzle.</li> </ul>
Valve clearance is wrong	<ul style="list-style-type: none"> <li>* Adjust valve clearance to 0.007–0.009 in. (0.18–0.22 mm) when the engine is cold.</li> </ul>
Leaking valves	<ul style="list-style-type: none"> <li>* Grind valve.</li> </ul>
Fuel injection timing is wrong	<ul style="list-style-type: none"> <li>* Adjust injection timing.</li> <li>* The injection timing is 25° before top dead-center.</li> </ul>
Engine oil becomes thick in cold weather and engine cranks slow.	<ul style="list-style-type: none"> <li>* Change grade of oil according to the weather (temperature).</li> </ul>
Low compression	<ul style="list-style-type: none"> <li>* Bad valve or excessive wear of rings, pistons and liners cause insufficient compression. Replace with new parts.</li> </ul>
Battery is discharged and the engine will not crank.	<ul style="list-style-type: none"> <li>* Charge battery.</li> <li>* Use decompression device.</li> <li>* In winter, always remove battery from tractor, charge fully and keep indoors. Install in tractor at time of use.</li> </ul>

### ■ When output is insufficient

Cause	Countermeasures
Carbon struck around orifice of nozzle piece	<ul style="list-style-type: none"> <li>* Clean orifice and needle valve, being very careful not to damage the nozzle orifice.</li> <li>* Check nozzle to see if good. If not, replace with new parts.</li> </ul>
Compression is insufficient. Leaking valves	<ul style="list-style-type: none"> <li>* Bad valve and excessive wear of rings, pistons and liners cause insufficient compression. Replace with new parts.</li> <li>* Grind valves.</li> </ul>
Fuel is insufficient	<ul style="list-style-type: none"> <li>* Check fuel system.</li> </ul>
Overheating of moving parts	<ul style="list-style-type: none"> <li>* Check lube oil system.</li> <li>* Check to see if lube oil filter is working properly.</li> <li>* Filter screens or elements deposited with impurities would cause poor lubrication. Clean screens.</li> <li>* Check to see if bearing clearance are within factory specs.</li> <li>* Check engine timing</li> <li>* Adjust timing 25° before top dead center.</li> </ul>
Valves out of adjustment	<ul style="list-style-type: none"> <li>* Adjust to proper valve clearance of 0.007–0.009 in. (0.18–0.22 mm) with engine cold.</li> </ul>
Air cleaner is dirty	<ul style="list-style-type: none"> <li>* Clean the element every 100-200 hours of operation.</li> </ul>
Fuel injection pressure is wrong	<ul style="list-style-type: none"> <li>* Adjust to proper pressure of 2000 psi (140 kg/cm<sup>2</sup>; 13.7 MPa)</li> </ul>
Injection pump wear	<ul style="list-style-type: none"> <li>* Do not use poor quality fuel for it will cause wear of the pump. Only use No.2 diesel fuel.</li> <li>* Check the fuel injection pump element and delivery valve assembly and replace as necessary.</li> </ul>

### ■ When engine suddenly stops

Cause	Countermeasures
Leak of fuel	<ul style="list-style-type: none"> <li>* Check the fuel tank and refill it necessary.</li> <li>* Also check the fuel system for air or leaks</li> </ul>

## 9.5 DIAGNOSIS OF ENGINE TROUBLE

### ■ When engine is difficult to start

Cause	Countermeasures
Fuel is thick and doesn't flow	<ul style="list-style-type: none"> <li>* Check the fuel oil tank and fuel oil filter.</li> <li>* Remove water, dirt and other impurities</li> <li>* As all fuel oil will be filtered by the filter, if there should be water or other foreign matters on the filter, clean with kerosene.</li> </ul>
Air or water mixed in fuel system	<ul style="list-style-type: none"> <li>* If air is in the fuel filter or injection lines, the fuel pump will not work properly. To attain proper fuel injection pressure, check carefully for loosened fuel line coupling, loose cap nut, etc.</li> <li>* Loosen air vent screws atop fuel filter and fuel injection pump to eliminate all the air in the fuel oil system.</li> </ul>
Thick carbon deposits on orifice of injection nozzle.	<ul style="list-style-type: none"> <li>* This is caused when water or dirt is mixed in the fuel. Clean the nozzle injection piece, being careful not to damage the orifice.</li> <li>* Check to see if nozzle is working properly or not. If not, install a new nozzle.</li> </ul>
Valve clearance is wrong	<ul style="list-style-type: none"> <li>* Adjust valve clearance to 0.007–0.009 in. (0.18–0.22 mm) when the engine is cold.</li> </ul>
Leaking valves	<ul style="list-style-type: none"> <li>* Grind valve.</li> </ul>
Fuel injection timing is wrong	<ul style="list-style-type: none"> <li>* Adjust injection timing.</li> <li>* The injection timing is 25° before top dead-center.</li> </ul>
Engine oil becomes thick in cold weather and engine cranks slow.	<ul style="list-style-type: none"> <li>* Change grade of oil according to the weather (temperature).</li> </ul>
Low compression	<ul style="list-style-type: none"> <li>* Bad valve or excessive wear of rings, pistons and liners cause insufficient compression. Replace with new parts.</li> </ul>
Battery is discharged and the engine will not crank.	<ul style="list-style-type: none"> <li>* Charge battery.</li> <li>* Use decompression device.</li> <li>* In winter, always remove battery from tractor, charge fully and keep indoors. Install in tractor at time of use.</li> </ul>

### ■ When output is insufficient

Cause	Countermeasures
Carbon struck around orifice of nozzle piece	<ul style="list-style-type: none"> <li>* Clean orifice and needle valve, being very careful not to damage the nozzle orifice.</li> <li>* Check nozzle to see if good. If not, replace with new parts.</li> </ul>
Compression is insufficient. Leaking valves	<ul style="list-style-type: none"> <li>* Bad valve and excessive wear of rings, pistons and liners cause insufficient compression. Replace with new parts.</li> <li>* Grind valves.</li> </ul>
Fuel is insufficient	<ul style="list-style-type: none"> <li>* Check fuel system.</li> </ul>
Overheating of moving parts	<ul style="list-style-type: none"> <li>* Check lube oil system.</li> <li>* Check to see if lube oil filter is working properly.</li> <li>* Filter screens or elements deposited with impurities would cause poor lubrication. Clean screens.</li> <li>* Check to see if bearing clearances are within factory specs.</li> <li>* Check engine timing</li> <li>* Adjust timing 25° before top dead center.</li> </ul>
Valves out of adjustment	<ul style="list-style-type: none"> <li>* Adjust to proper valve clearance of 0.007–0.009 in. (0.18–0.22 mm) with engine cold.</li> </ul>
Air cleaner is dirty	<ul style="list-style-type: none"> <li>* Clean the element every 100-200 hours of operation.</li> </ul>
Fuel injection pressure is wrong	<ul style="list-style-type: none"> <li>* Adjust to proper pressure of 2000 psi (140 kg/cm<sup>2</sup>; 13.7 MPa)</li> </ul>
Injection pump wear	<ul style="list-style-type: none"> <li>* Do not use poor quality fuel for it will cause wear of the pump. Only use No.2 diesel fuel.</li> <li>* Check the fuel injection pump element and delivery valve assembly and replace as necessary.</li> </ul>

■ When engine suddenly stops

Cause	Countermeasures
Leak of fuel	<ul style="list-style-type: none"> <li>* Check the fuel tank and refill it necessary.</li> <li>* Also check the fuel system for air or leaks</li> </ul>

## 9.6 TRANSMISSION LUBRICATION

After the first 50 hours of operation of a new tractor and 300 hours thereafter, exchange oil.

Oil used in the transmission case should have an SAE classification of SAE 80 in all season.

It is easier to exchange oil while the engine is warm.

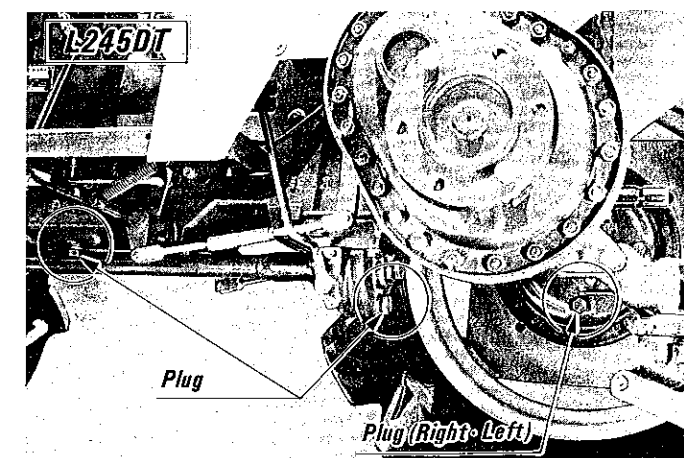
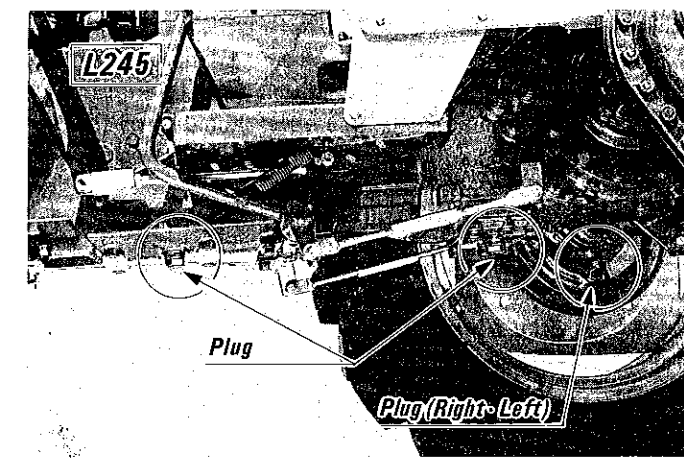
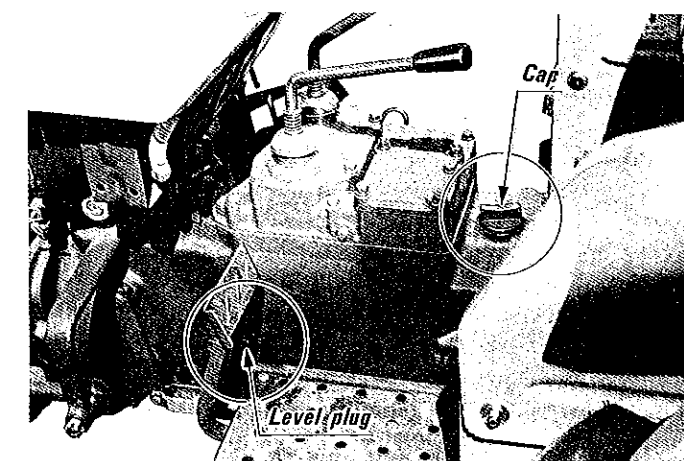

Bad nozzle	<ul style="list-style-type: none"> <li>* If necessary, replace with a new nozzle.</li> </ul>
Moving parts are overheated due to shortage of lube oil or improper lubrication	<ul style="list-style-type: none"> <li>* Check amount of engine oil with oil level gage.</li> <li>* Check lubricating oil system.</li> <li>* Check to see if element inside the lubricating oil filter (2) has become old and clogged. If necessary, replace with new element.</li> <li>* Check to see if the engine bearing clearances is within factory specs.</li> </ul>

### [CAUTION]

When the engine has suddenly stopped, decompress the engine by the decomp and turn the engine lightly by pulling on the fan belt. If the engine turns easily without abnormalities, the cause of the trouble is usually lack of fuel or bad nozzle.

### ■ When color of exhaust is specially bad

Cause	Countermeasures
Fuel governing device bad	<ul style="list-style-type: none"> <li>* Contact dealer for repairs</li> </ul>
Fuel is of extremely poor quality	<ul style="list-style-type: none"> <li>* Select good quality fuel oil. No.2 diesel only.</li> </ul>
Nozzle is bad	<ul style="list-style-type: none"> <li>* If necessary replace with new nozzle.</li> </ul>
Combustion is incomplete	<ul style="list-style-type: none"> <li>* Cause is poor atomization, improper injection timing, etc. because of trouble in injection system or in poor valve adjustment, or compression leakage, poor compression, etc. Check for the cause.</li> </ul>

### ■ When engine must be stopped immediately

Cause	Countermeasures
Speed suddenly decreases or increases	<ul style="list-style-type: none"> <li>* Check the adjustments and timing of injection and the fuel system.</li> </ul>
Unusual sound is heard suddenly.	<ul style="list-style-type: none"> <li>* Check all moving parts carefully.</li> </ul>
Color of exhaust suddenly turns dark	<ul style="list-style-type: none"> <li>* Check the fuel injection system, especially the fuel injection nozzle.</li> </ul>
Bearing parts are overheated	<ul style="list-style-type: none"> <li>* Check the lubricating system.</li> </ul>
Oil lamp lights up during operation	<ul style="list-style-type: none"> <li>* Check lubricating system.</li> <li>* Check to see if the engine bearing clearances is within factory specs.</li> <li>* Check the function of the regulating valve inside of oil filter (2).</li> <li>* Check pressure switch</li> <li>* Check filter base gasket</li> </ul>

# 10 Change of Wheel Treads

When working the fields where plants are in rows, it is necessary to change the wheel tread so that the tires would not pass over the plants. It is also necessary to widen wheel tread to decrease danger when working on slopes or hills, or when doing trailer work, etc.

## 10.1 CHANGE FRONT WHEEL TREAD

It is possible to change the front tread 4 stages from 37-3/4 in. to 51-5/8 in. (990mm to 1,310 mm).

- (1) Loosen nut (2) of clamp (1) on the outer pipe of tie-rod, and remove bolt (3)
- (2) Lift the front part of the tractor with a jack. loosen nut (4) and remove bolt (5), four bolts. Then it is possible to separate the front axle (left) (right), and (center).
- (3) Insert bolt (5) into the hole of the desired width and tighten with nut (4). Insert bolt (3) into the inner pipe of the tie-rod and tighten.
- (4) Select the boltholes for the front axle (side), and (center) according to the diagram.

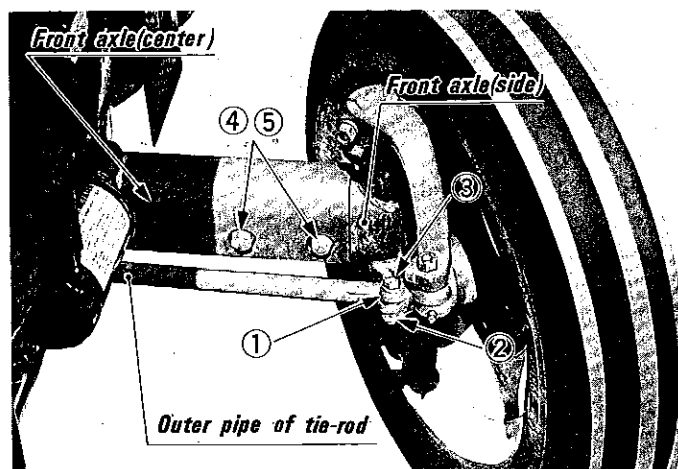

### [IMPORTANT]

- \* The front wheel tread of L245DT cannot be adjusted.
- \* Always attach tires as shown in the following drawing. Be careful to attach properly.

L245FP Front Wheel Tread Chart

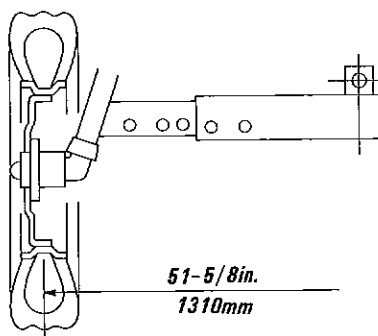
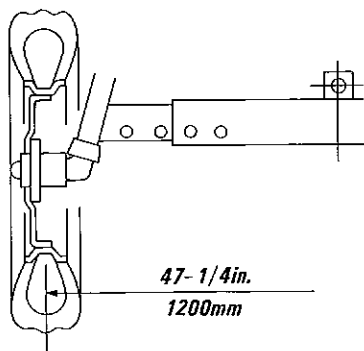
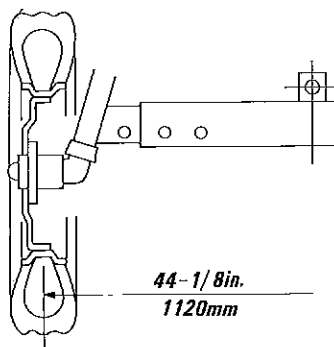
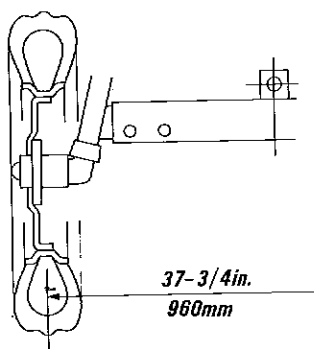

L245TP Wheel Setting

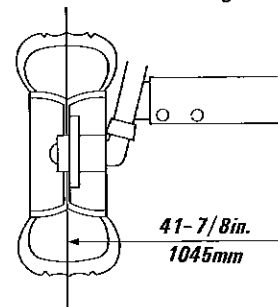

L245DTP Wheel Setting

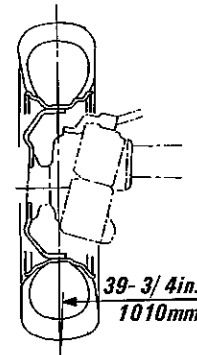



## 9.7 ADJUSTING CLUTCH

### \* Adjustment of Clutch Pedal Free Travel:

Free travel of the clutch pedal is governed by the clearance of release thrust ball bearing to the release levers. This clearance is set to 0.098 to 0.12 in (2.5 to 3 mm) when the tractor leaves the factory, but this changes with use. It is general that at the beginning of use it increases but then turns to smaller with use. If the pedal should be used with no clearance here it will result in the seizure of release bearing or the wear of facing. Therefore, be sure to check and adjust at each periodical maintenance service.

### To Adjust:

- (1) Open the clutch access window which is located on the right hand forward of the clutch housing.
- (2) Insert a 0.098 to 0.12 in (2.5 to 3.0 mm) thickness gauge between the release thrust ball bearing and the release levers. Adjust the clearance by the length of the clutch rod.
  - \* Lengthen the rod when the clearance is wider.
  - \* Shorten the rod when the clearance is narrower.
- (3) Depress the clutch pedal, and check and make certain that the free travel at the tip of the pedal is 1 to 1-3/8 in (25 to 35 mm).
- (4) With the clutch pedal depressed to the lowest point, confirm that there is adequate gap between the clutch rod and safety starter switch.

### [CAUTION]

Adjustment of the clutch pedal free travel should be performed as explained above and should not be judged by sight alone.

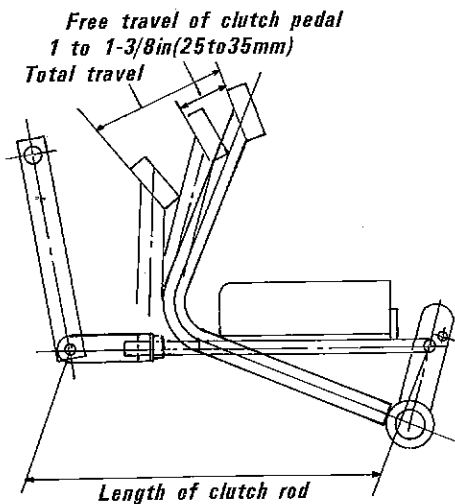

## 9.8 CHECK TIRE PRESSURE

Model	Tires	Inflation Pressure
Rear	F	11.2/10-24 R-1 14 psi (1.0 kgf/cm <sup>2</sup> ; 0.1 MPa)
	T	13.6-16 R-3 14 psi (1.0 kgf/cm <sup>2</sup> ; 0.1 MPa)
	DT	11.2/10-24 R-1 14 psi (1.0 kgf/cm <sup>2</sup> ; 0.1 MPa)
Front	F	5.00-15 32 psi (2.2 kgf/cm <sup>2</sup> ; 0.22 MPa)
	T	20x8.00-10 24 psi (1.7 kgf/cm <sup>2</sup> ; 0.17 MPa)
	DT	7-16 26 psi (1.8 kgf/cm <sup>2</sup> ; 0.18 MPa)

The air pressure in the tires whether too much or too little would affect the life of the tire. Make routine checks of the air pressure in the tires so that the air would be of suitable pressure.

The range of the rear wheel tire pressure is as of above but it would be possible to get better performance from the tractor if the tire pressure is on the lower side of above pressure when working in fields, and on the higher side when travelling on roads.

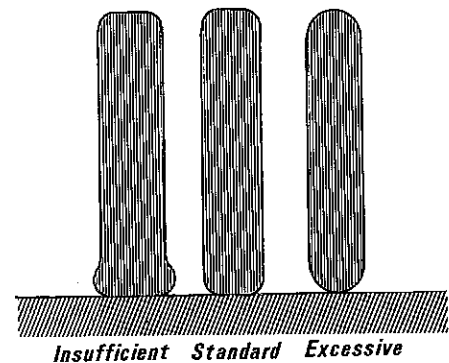



# 11 Wiring Diagram

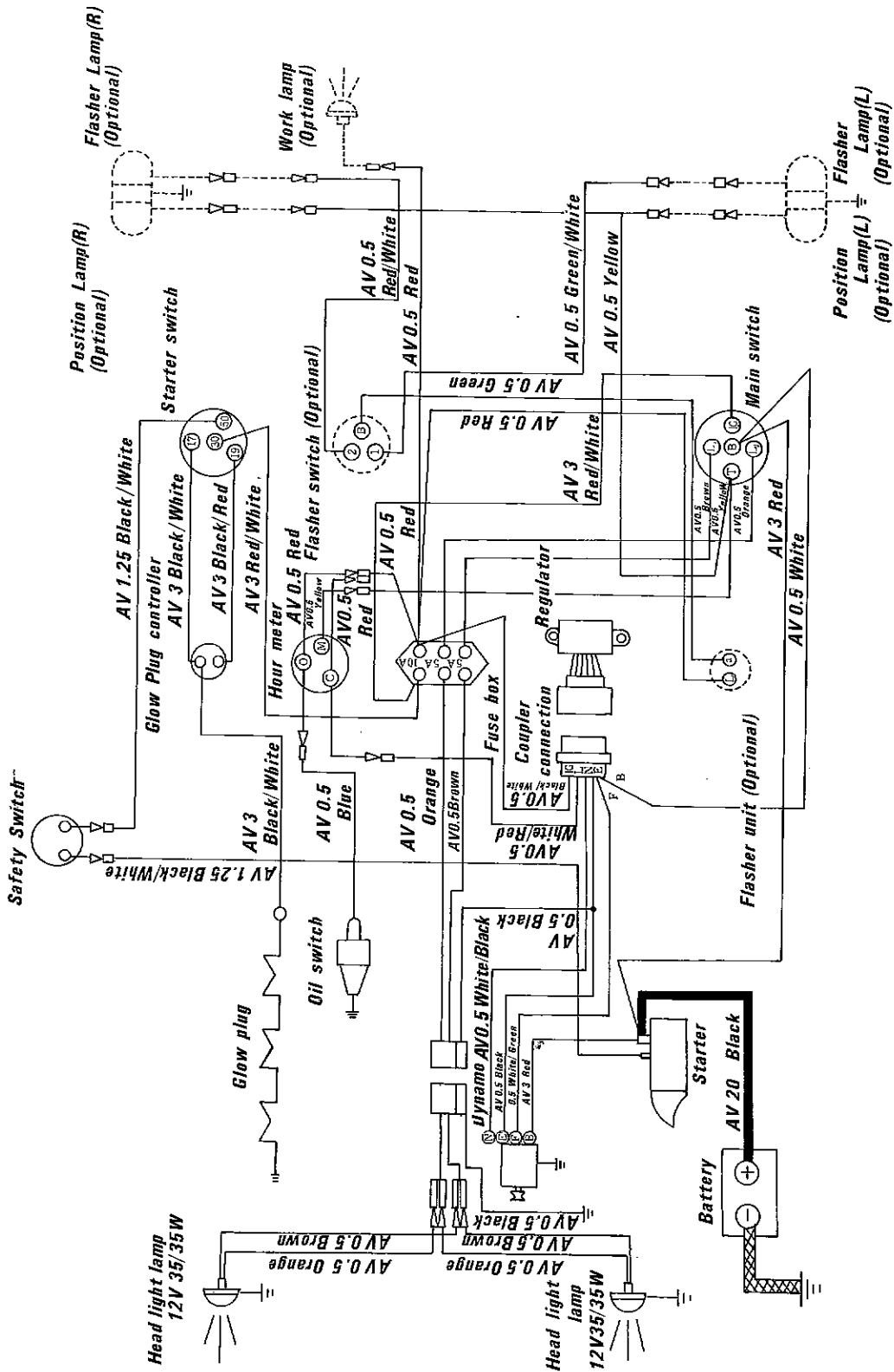

# 11 Wiring Diagram

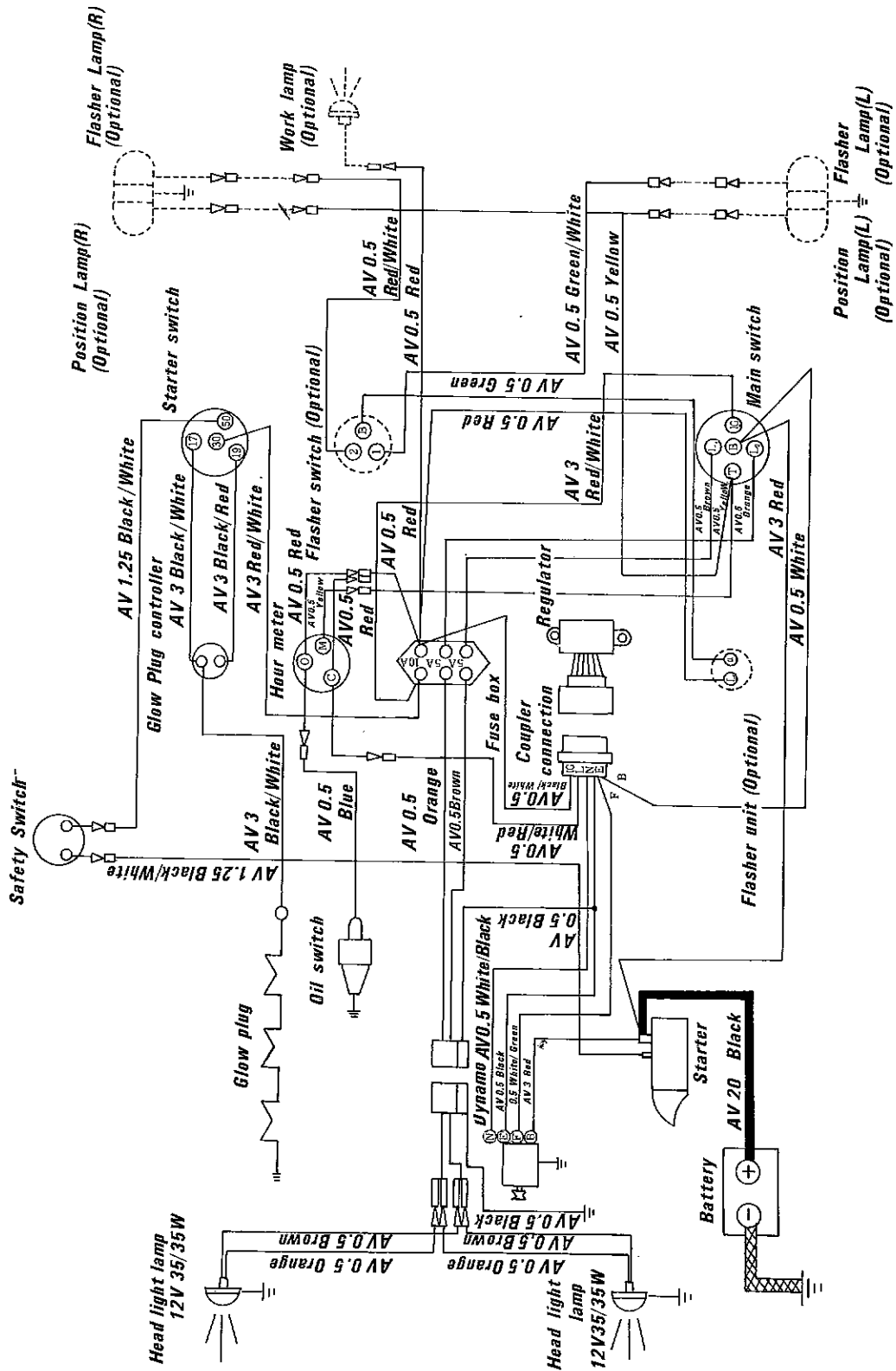

# 12 Maintenance Check List

[Note] Make sure to stop engine completely prior to checking and adjustment.

## Maintenance Check List

(for details please refer to the attached check list.)

Frequency of check	Checks	Notes																				
Initial operation (first 60 hours)	<p>During this period, pay careful attention to the following:</p> <ol style="list-style-type: none"> <li>1) After the first 35 hours of use, change the engine oil and clean the oil filter of the hydraulic mechanism.</li> <li>2) After the first 50 hours of use, change the transmission oil.</li> <li>3) Sudden starting or sudden braking should be avoided.</li> <li>4) When the outside temperature is low, allow the engine to warm-up prior to operation.</li> <li>5) Unusually fast driving must be avoided.</li> <li>6) Reduce speed on slopes or during bad road conditions.</li> </ol>																					
Daily checks (check every-time prior to use)	<ol style="list-style-type: none"> <li>1) Check completely all abnormalities found during previous operation.</li> <li>2) Go around the tractor and check the following points:               <ol style="list-style-type: none"> <li>1. Air pressure, wear and general condition of tires</li> <li>2. Oil or water leakage</li> <li>3. Amount of engine oil and degree of contamination</li> <li>4. Amount of transmission oil and degree of contamination</li> <li>5. Amount of fuel and coolant</li> <li>6. Condition of dust cup in air cleaner</li> <li>7. Tractor body for damage, loosened bolts and nuts</li> <li>8. Condition of lamps</li> <li>9. Dirt or damage of the number plate</li> </ol> </li> <li>3) While in the driver's seat check the following:               <ol style="list-style-type: none"> <li>10. Operation of brake pedals and clutch pedals</li> <li>11. Operation of parking brake.</li> <li>12. Operation of steering wheel</li> <li>13. Dirt on lamps and operation of lamps</li> <li>14. Operation of all meters and gauges.</li> <li>15. Color of exhaust gas</li> <li>16. Operation of wipers (optional)</li> </ol> </li> </ol>	<table border="1"> <tbody> <tr> <td rowspan="3">Rear</td> <td>F</td> <td>11.2/10-24 R-1</td> <td>14 psi (1.0 kgf/cm<sup>2</sup>; 0.1 MPa)</td> </tr> <tr> <td>T</td> <td>13.6-16 R-3</td> <td>14 psi (1.0 kgf/cm<sup>2</sup>; 0.1 MPa)</td> </tr> <tr> <td>DT</td> <td>11.2/10-24 R-1</td> <td>14 psi (1.0 kgf/cm<sup>2</sup>; 0.1 MPa)</td> </tr> <tr> <td rowspan="3">Front</td> <td>F</td> <td>5.00-15</td> <td>32 psi (2.2 kgf/cm<sup>2</sup>; 0.22 MPa)</td> </tr> <tr> <td>T</td> <td>20x8.00-10</td> <td>24 psi (1.7 kgf/cm<sup>2</sup>; 0.17 MPa)</td> </tr> <tr> <td>DT</td> <td>7-16</td> <td>26 psi (1.8 kgf/cm<sup>2</sup>; 0.18 MPa)</td> </tr> </tbody> </table> <p>The oil level must be between the two marks on the dipstick. The oil level must be to the top line on the dipstick. Stop the engine while adding oil. Do not add oil near an open flame.</p>	Rear	F	11.2/10-24 R-1	14 psi (1.0 kgf/cm <sup>2</sup> ; 0.1 MPa)	T	13.6-16 R-3	14 psi (1.0 kgf/cm <sup>2</sup> ; 0.1 MPa)	DT	11.2/10-24 R-1	14 psi (1.0 kgf/cm <sup>2</sup> ; 0.1 MPa)	Front	F	5.00-15	32 psi (2.2 kgf/cm <sup>2</sup> ; 0.22 MPa)	T	20x8.00-10	24 psi (1.7 kgf/cm <sup>2</sup> ; 0.17 MPa)	DT	7-16	26 psi (1.8 kgf/cm <sup>2</sup> ; 0.18 MPa)
Rear	F	11.2/10-24 R-1		14 psi (1.0 kgf/cm <sup>2</sup> ; 0.1 MPa)																		
	T	13.6-16 R-3		14 psi (1.0 kgf/cm <sup>2</sup> ; 0.1 MPa)																		
	DT	11.2/10-24 R-1	14 psi (1.0 kgf/cm <sup>2</sup> ; 0.1 MPa)																			
Front	F	5.00-15	32 psi (2.2 kgf/cm <sup>2</sup> ; 0.22 MPa)																			
	T	20x8.00-10	24 psi (1.7 kgf/cm <sup>2</sup> ; 0.17 MPa)																			
	DT	7-16	26 psi (1.8 kgf/cm <sup>2</sup> ; 0.18 MPa)																			
Every 50 hours	<ol style="list-style-type: none"> <li>1) Lubrication               <ol style="list-style-type: none"> <li>1. Front axle (in the center)</li> <li>2. Front axle (on right and left sides)</li> <li>3. Connection of clutch and brake pedals (three points)</li> <li>4. Right side of lifting rod (two points)</li> <li>5. Drag link end (two points)</li> <li>6. Tie rod end (two points)</li> <li>7. Knuckle pin (on right and left sides) L245DT)</li> <li>8. Center-pin (L245DT)</li> <li>9. Front wheel drive lever (L245DT)</li> </ol> </li> <li>2) Check to make sure fixing screws of oil pressure pipe and fuel pipe are tight.</li> </ol>	Apply a small amount of chassis grease.																				
Every 75 hours	<ol style="list-style-type: none"> <li>1) Change engine oil.</li> </ol>	Amount of oil: 5.2 Quarts (4.9ℓ)																				

Frequency of check	Checks	Notes
Every 100 hours	<ol style="list-style-type: none"> <li>1) Cleaning of air cleaner element</li> <li>2) Amount of battery electrolyte fluid.</li> <li>3) Toe-in check</li> </ol>	<p>Wash away old oil with pure Element detergent.</p> <p>The difference between the front and rearmost ends of wheels should be between 1/16–5/16 in. (2–8mm)</p>
Every 150 hours	<ol style="list-style-type: none"> <li>1) Check that the radiator hose is fastened securely.</li> <li>2) Check oil level of steering gear box.</li> <li>3) Change oil filter element (2).</li> <li>4) Check fuel pipe, radiator pipe, oil pressure pipe</li> </ol>	<p>The oil level should reach just below the supply hole. 0.3 Quarts (0.3ℓ) (Gear oil SAE 80)</p> <p>Insert a new element after washing inside of filter with light oil.</p>
Every 200 hours	<ol style="list-style-type: none"> <li>1) Check that the clutch pedal works properly and has sufficient play.</li> <li>2) Check that the brake pedals work properly and have sufficient play.</li> <li>3) Check that fan belt tension is proper.</li> <li>4) Check that the steering wheel works properly.</li> <li>5) Clean oil pressure filter.</li> <li>6) Check front wheel shaft supporters so that no vibration occurs during operation.</li> </ol>	<p>1–1-3/8 in. (25–35mm)</p> <p>1–1-3/8 in. (25–35mm)</p> <p>Adjust fan belt so that it has about 9/32 in. (7mm) play in tension.</p> <p>13/16–2 in. (20–50mm) at outer circumference.</p> <p>Wash with kerosene or light oil.</p>
Every 300	<ol style="list-style-type: none"> <li>1) Clean fuel tank.</li> <li>2) Change transmission oil.</li> <li>3) Apply grease to clutch release hub.</li> <li>4) Check that bearing, cylinder head and pump connections are tight.</li> <li>5) Apply grease to the front wheel hubs (right and left sides, two points each) (L245)</li> <li>6) Change front diff-gear case oil (right and left) (L245DT)</li> <li>7) Change front wheel shaft oil (right and left) (L245DT)</li> </ol>	<p>23.2 Qts. (22ℓ) (Gear oil SAE 80)</p> <p>24.3 Qts. (23ℓ) (L185DT) (Gear oil SAE 80)</p> <p>Apply small amount of bearing grease (two pumps of manual grease gun)</p> <p>Apply a small amount of bearing grease.</p> <p>1.6 oz (45 gf) of bearing grease.</p> <p>1.2 Qts. (1.1ℓ) (Gear oil SAE 90)</p> <p>0.8 Qts. (0.8ℓ) (Gear oil SAE 90)</p>
Every 400 hours	<ol style="list-style-type: none"> <li>1) Change fuel filter.</li> </ol>	<ol style="list-style-type: none"> <li>1. Tighten cock of fuel filter and then replace filter.</li> <li>2. Dampen gasket with fuel and hand tighten.</li> <li>3. Make sure all air is bled from fuel line after installation of new filter.</li> </ol>
Every 500 hours	<ol style="list-style-type: none"> <li>1) Clean engine cooling system</li> </ol>	
After one year's use (every 6 cleaning)	<ol style="list-style-type: none"> <li>1) Change air cleaner element.</li> </ol>	
After two year's use	<ol style="list-style-type: none"> <li>1) Change fuel pipe, water pipe and connector of oil pressure pipe.</li> </ol>	