

STK# 6945

OPERATOR'S MANUAL

KUBOTA TRACTOR

MODELS L2900 • L3300
L3600 • L4200



P-7636

MOD# Ser#

33C0D 50671

Eng. D1703-A 2. 37

READ AND SAVE THIS MANUAL

Kubota

ABBREVIATION LIST

Abbreviations	Definitions
2WD	Two Wheel Drive
4WD	Four Wheel Drive
API	American Petroleum Institute
ASAE	American Society of Agricultural Engineers, USA
ASTM	American Society for Testing and Materials, USA
DIN	Deutsches Institut für Normung, GERMANY
DT	Dual Traction [4WD]
fpm	Feet Per Minute
GST	Glide Shift Transmission
Hi-Lo	High Speed-Low Speed
HST	Hydrostatic Transmission
m/s	Meters Per Second
PTO	Power Take Off
RH/LH	Right-hand and left-hand sides are determined by facing in the direction of forward travel
ROPS	Roll-Over Protective Structures
rpm	Revolutions Per Minute
r/s	Revolutions Per Second
SAE	Society of Automotive Engineers, USA
SMV	Slow Moving Vehicle

UNIVERSAL SYMBOLS

As a guide to the operation of your tractor, various universal symbols have been utilized on the instruments and controls. The symbols are shown below with an indication of their meaning.

	Safety Alert Symbol		Remote Cylinder-Retract
	Diesel Fuel		Remote Cylinder-Extend
	Fuel-Level		Steering Wheel-Tilt Control
	Engine-Rotational Speed		Hazard Warning Lights
	Hourmeter/Elapsed Operating Hours		Headlight-Low Beam
	Engine Coolant-Temperature		Headlight-High Beam
	Diesel Preheat/Glow Plugs(Low Temperature Start Aid)		Four-Wheel Drive-On
	Parking Brake		Four-Wheel Drive-Off
	Engine Intake/Combustion Air-Filter		Fast
	Battery Charging Condition		Slow
	Engine Oil-Pressure		Creep
	Turn Signal		Read Operator's Manual
	Engine-Stop		Tractor-Forward Movement-Overhead View of Machine
	Engine Shut-Off Control		Tractor-Rearward Movement-Overhead View of Machine
	Engine-Run		Engine Speed Control
	Starter Control		
	Power Take-Off Clutch Control-Off Position		
	Power Take-Off Clutch Control-On Position		
	Differential Lock		
	Position Control-Raised Position		
	Position Control-Lowered Position		
	Draft Control-Shallow Position		
	Draft Control-Deep Position		
	3-Point Lowering Speed Control		

FOREWORD

You are now the proud owner of a KUBOTA Tractor. This tractor is a product of KUBOTA quality engineering and manufacturing. It is made of fine materials and under a rigid quality control system. It will give you long, satisfactory service. To obtain the best use of your tractor, please read this manual carefully. It will help you become familiar with the operation of the tractor and contains many helpful hints about tractor maintenance. It is KUBOTA's policy to utilize as quickly as possible every advance in our research. The immediate use of new techniques in the manufacture of products may cause some small parts of this manual to be outdated. KUBOTA distributors and dealers will have the most up-to-date information. Please do not hesitate to consult with them.



SAFETY FIRST

This symbol, the industry's "Safety Alert Symbol", is used throughout this manual and on labels on the machine itself to warn of the possibility of personal injury. Read these instructions carefully. It is essential that you read the instructions and safety regulations before you attempt to assemble or use this unit.



DANGER : Indicates an imminently hazardous situation which, if not avoided, will result in death or serious injury.



WARNING : Indicates a potentially hazardous situation which, if not avoided, could result in death or serious injury.



CAUTION: Indicates a potentially hazardous situation which, if not avoided, may result in minor or moderate injury.

IMPORTANT : Indicates that equipment or property damage could result if instructions are not followed.

NOTE : Gives helpful information.

CONTENTS

▲ SAFE OPERATION 1

SERVICING OF TRACTOR7

SPECIFICATIONS8

SPECIFICATION TABLE[GST Type]8

SPECIFICATION TABLE

[Manual Transmission type]9

TRAVELING SPEEDS 10

IMPLEMENT LIMITATIONS 11

Operation Section

INSTRUMENT PANEL AND CONTROLS .. 13

PRE-OPERATION CHECK 15

DAILY CHECK 15

OPERATING THE ENGINE 16

STARTING THE ENGINE 16

COLD WEATHER STARTING 19

STOPPING THE ENGINE 19

WARMING UP20

JUMP STARTING20

OPERATING THE TRACTOR21

OPERATING NEW TRACTOR21

STARTING21

STOPPING28

CHECK DURING DRIVING29

PARKING30

OPERATING TECHNIQUES30

PTO32

PTO OPERATION32

THREE-POINT HITCH & DRAWBAR34

3-POINT HITCH35

DRAWBAR36

HYDRAULIC UNIT37

3-POINT HITCH CONTROL SYSTEM37

REMOTE HYDRAULIC

CONTROL SYSTEM (if equipped)40

TIRES, WHEELS AND BALLAST42

TIRES42

WHEEL ADJUSTMENT42

BALLAST46

Maintenance Section

MAINTENANCE49

SERVICE INTERVALS49

LUBRICANTS50

PERIODIC SERVICE51

HOW TO OPEN THE HOOD51

DAILY CHECK51

EVERY 50 HOURS54

EVERY 100 HOURS58

EVERY 200 HOURS61

EVERY 400 HOURS63

EVERY 800 HOURS65

EVERY 1 YEAR65

EVERY 2 YEARS65

SERVICE AS REQUIRED66

STORAGE69

TRACTOR STORAGE69

REMOVING THE TRACTOR

FROM STORAGE69

TROUBLESHOOTING70

ENGINE TROUBLESHOOTING70

OPTIONS71



SAFE OPERATION

Careful operation is your best insurance against an accident.

Read and understand this section carefully before operating the tractor.

All operators, no matter how much experience they may have had, should read this and other related manuals before operating the tractor or any implement attached to it. It is the owner's obligation to instruct all operators in safe operation.

1. BEFORE OPERATING THE TRACTOR

- (1) Know your equipment and its limitations. Read this entire manual before attempting to start and operate the tractor.
- (2) Pay special attention to the danger, warning and caution labels on the tractor itself.
- (3) KUBOTA recommends the use of a Roll Over Protective Structures (ROPS) and seat belt in almost all applications. This combination will reduce the risk of serious injury or death, should the tractor be upset.

If the ROPS is loosened or removed for any reason, make sure that all parts are reinstalled correctly before operating the tractor.

Never modify or repair a ROPS because welding, bending, drilling, grinding, or cutting any portion may weaken the structure.

A damaged ROPS structure must be replaced, not repaired or revised. If any structural member of the ROPS is damaged, replace the entire structure at your local KUBOTA dealer.

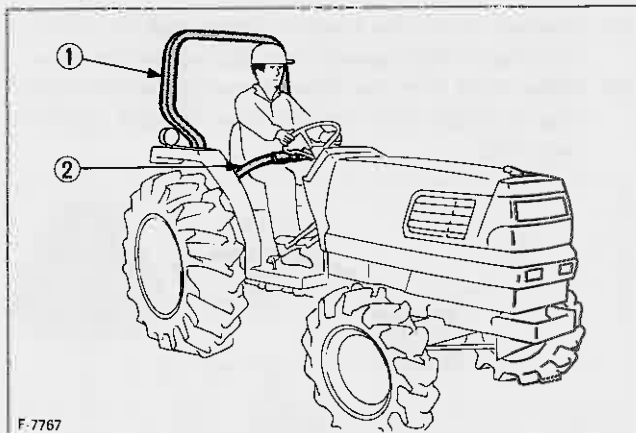

- ① ROPS
- ② Seat belt

- (4) Always use the seat belt if the tractor has a ROPS. Do not use it if there is no ROPS. Check the seat belt regularly and replace if frayed or damaged.
- (5) Do not operate tractor or any implement attached to it while under the influence of alcohol, medication, or other substances or while fatigued.

- (6) Carefully check the vicinity before operating tractor or any implement attached to it. Check for overhead clearance which may interfere with a ROPS. Do not allow any bystanders around or near tractor during operation.
- (7) Before allowing other people to use your tractor, explain how to operate and have them read this manual before operation.
- (8) Never wear loose, torn, or bulky clothing around tractor. It may catch on moving parts or controls, leading to the risk of accident. Use additional safety items, e.g. hard hat, safety boots or shoes, eye and hearing protection, gloves, etc. as appropriate or required.
- (9) Do not allow passengers to ride on any part of the tractor at anytime. The operator must remain in the tractor seat throughout operation.
- (10) Check brakes, clutch, and other mechanical parts for improper adjustment and wear. Replace worn or damaged parts promptly. Check the tightness of all nuts and bolts regularly. (For further details, see Maintenance section.)
- (11) Keep your tractor clean. Dirt, grease, and trash accumulations contribute to fires and lead to personal injury.
- (12) Use only implements meeting the specifications listed under IMPLEMENT LIMITATIONS in this manual and use only implements approved by KUBOTA.
- (13) Use proper weights to front or rear of tractor to reduce the risk of upsets. When using the front loader, put the implement or ballast on 3-point hitch to improve stability. Follow the safe operating procedures specified in the attached manual to the equipment.
- (14) The narrower the tread, the greater the risk of a tractor upset. For maximum stability, adjust the wheels to the widest practical tread width. (See "TIRES, WHEELS AND BALLAST" Section)

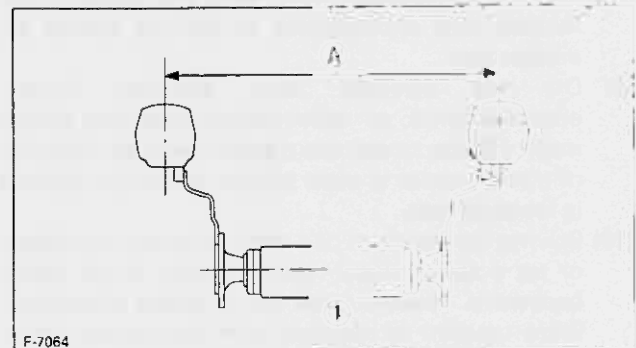

- ① Rear wheels Ⓐ Tread Width

- (15) Do not modify the tractor if special applications may be unsafe.

2. OPERATING THE TRACTOR

- (1) Never start engine or operate levers from anywhere other than the seat.
- (2) Before, starting the engine, make sure that all levers (including auxiliary control levers) are in their neutral positions, that the parking brake is engaged, and that both the clutch and the Power Take-Off (PTO) are disengaged. Fasten the seat belt if the tractor has a ROPS.
- (3) Do not start engine by shorting across starter terminals or bypassing the safety start switch. Machine may start in gear and move if normal starting circuitry is bypassed.
- (4) Pull only from the drawbar. Never hitch to axle housing or any other point except drawbar; such arrangements only increase the risk of serious personal injury or death due to a tractor upset.

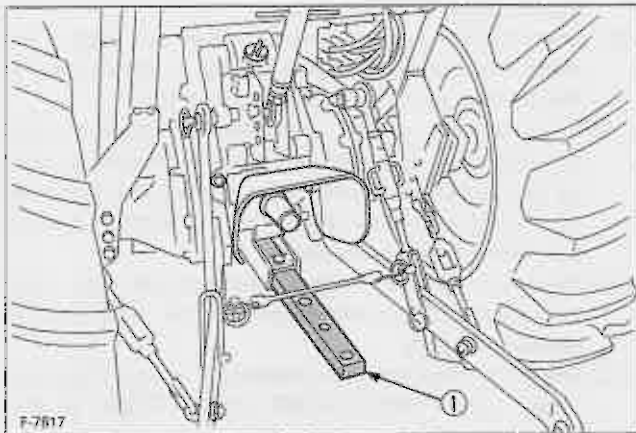

① Drawbar

- (5) Do not operate or idle engine in a non-ventilated area. Carbon monoxide gas is colorless, odorless, and deadly.
- (6) Keep all shields and guards in place. Replace any that are missing or damaged.
- (7) Avoid sudden starts. To avoid upsets, slow down when turning, **on uneven terrain**, and before stopping.
- (8) The tractor cannot turn with the differential locked and attempting to do so could be dangerous.
- (9) Do not operate near ditches, holes, embankments, or other terrain features which may collapse under the tractor's weight. The risk of tractor upset is even higher when the ground is loose or wet.
- (10) Driving forward out of a ditch or mired condition or up a steep slope risks a tractor to be upset backward. Always back out of these situations. Extra caution is required with four-wheel drive models because their higher traction can give the operator false confidence in the tractor's ability to climb slopes.

- (11) To avoid upsets, always back up steep slopes. Stay off hills and slopes too steep for safe operation.
- (12) Watch where you are going at all times. Watch for and avoid obstacles. Be alert at row ends, near trees, and other obstructions.
- (13) When working in groups, always let the others know what you are going to do before you do it.
- (14) Never "freewheel". Disengaging the clutch or shifting into neutral while descending a slope could lead to a loss of control.
- (15) Never try to get on or off a moving tractor.

3. DRIVING THE TRACTOR ON THE ROAD

- (1) Lock the two brake pedals together to help assure straight-line stops. Uneven braking at road speeds could cause the tractor to tip over.

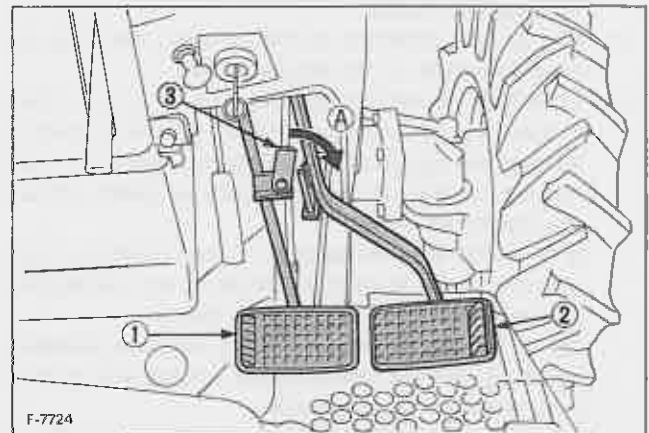

① Brake pedal (LH) A Whenever travelling on the road
 ② Brake pedal (RH)
 ③ Brake pedal lock

- (2) Always slow the tractor down before turning. Turning at high speed may tip the tractor over.
- (3) Make sure that the Slow Moving Vehicle (SMV) sign is clean and visible. Use hazard lights as required.

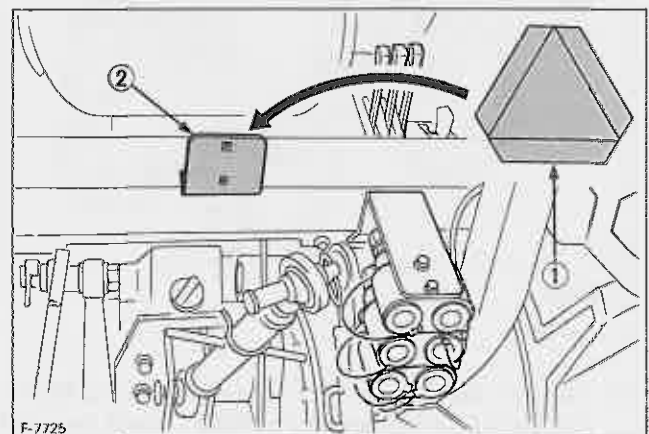

① SMV emblem
 ② Bracket

- (4) Observe all local traffic and safety regulations.
- (5) Turn the headlights on. Dim them when meeting another vehicle.
- (6) Drive at speeds that allow you to maintain control at all times.
- (7) Do not apply the differential lock while traveling at road speeds. The tractor may run out of control.
- (8) Avoid sudden motions of the steering wheel as they can lead to a dangerous loss of stability. The risk is especially great when the tractor is traveling at road speeds.
- (9) Do not operate an implement while the tractor is on the road. Lock the 3-point hitch in the raised position.
- (10) When towing other equipment, use a safety chain and place an SMV emblem on it as well.

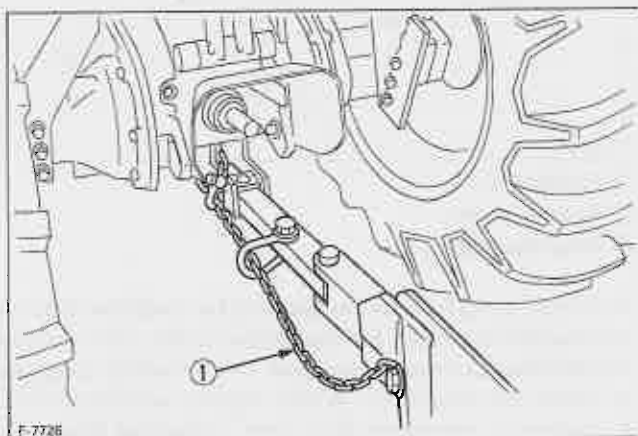

① Safety chain

4. PARKING THE TRACTOR

- (1) Disengage the PTO, lower all implements, place all control levers in their neutral positions, set the parking brake, stop the engine, and remove the key.
- (2) Make sure that the tractor has come to a complete stop before dismounting.

5. OPERATING THE PTO

- (1) Wait until all moving components have completely stopped before getting off the tractor, connecting, disconnecting, adjusting, cleaning, or servicing any PTO driven equipment.
- (2) Keep the PTO shaft cover in place at all times. Replace the PTO shaft cap when the shaft is not in use.

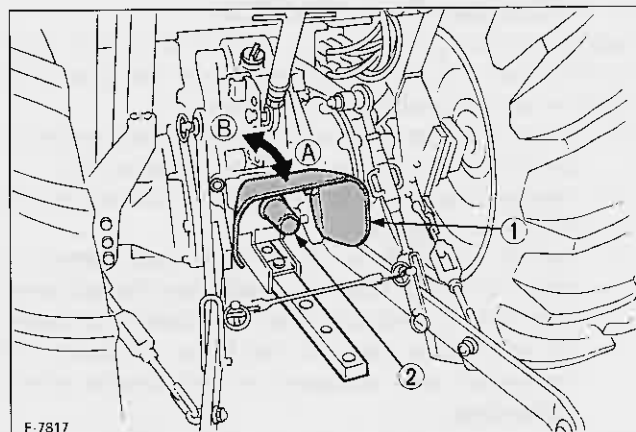

① PTO shaft cover A "NORMAL POSITION"
② PTO shaft cap B "RAISED POSITION"

- (3) Before installing or using PTO driven equipment, read the manufacturer's manual and review the safety labels attached to the equipment.
- (4) When operating stationary PTO driven equipment, always apply the tractor parking brake and place chocks behind and in front of the rear wheels. Stay clear of all rotating parts.

6. USING 3-POINT HITCH

- (1) Use the 3-point hitch only with equipment designed for 3-point hitch usage.
- (2) When using a 3-point hitch mounted implement, be sure to install the proper counterbalance weight on the front of the tractor.
- (3) When transporting on the road, set the implement lowering control in the "LOCK" position to hold the implement in the raised position.

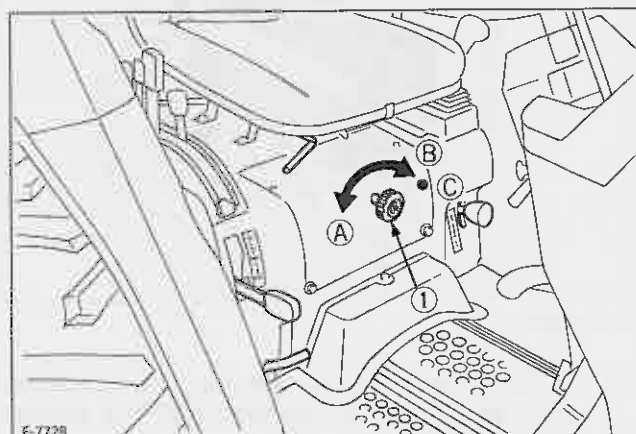

① 3-point hitch lowering speed knob A "FAST"
B "SLOW"
C "LOCK"

7. SERVICING THE TRACTOR

Before servicing the tractor, park it on a firm level surface, set the parking brake, place the gear shift lever in neutral and stop the engine.

- (1) Allow the tractor time to cool off before working on or near the engine, muffler, radiator, etc.
- (2) Always stop the engine before refueling. Avoid spills and overfilling.
- (3) Do not smoke when working around battery or when refueling. Keep all sparks and flames away from battery and fuel tank. The battery presents an explosive hazard because it gives off hydrogen and oxygen ••• especially when recharging.
- (4) Before "jump starting" a dead battery, read and follow all of the instructions. (See "JUMP STARTING" in Operating the Engine Section)
- (5) Keep first aid kit and fire extinguisher handy at all times.
- (6) Do not remove radiator cap while coolant is hot. When cool, slowly rotate cap to the first stop and allow sufficient time for excess pressure to escape before removing the cap completely. If the tractor has a coolant recovery tank, add coolant there instead of to the radiator.
- (7) Disconnect the battery's ground cable before working on or near electric components.
- (8) To avoid sparks from an accidental short circuit, always disconnect the battery's ground cable ⊖ first and connect it last.

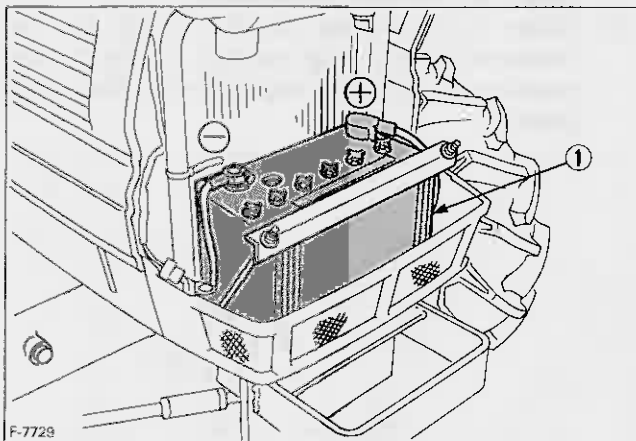

① Battery

- (9) Do not attempt to mount a tire. This should be done by a qualified person with the proper equipment.
- (10) Securely support the tractor when changing wheels or the wheel tread width.
- (11) Make sure that wheel bolts have been tightened to the specified torque.

- (12) Escaping hydraulic fluid under pressure has sufficient force to penetrate skin, causing serious personal injury. Before disconnecting hydraulic lines, be sure to release all residual pressure. Before applying pressure to the hydraulic system, make sure that all connections are tight and that all lines, pipes, and hoses are free of damage.

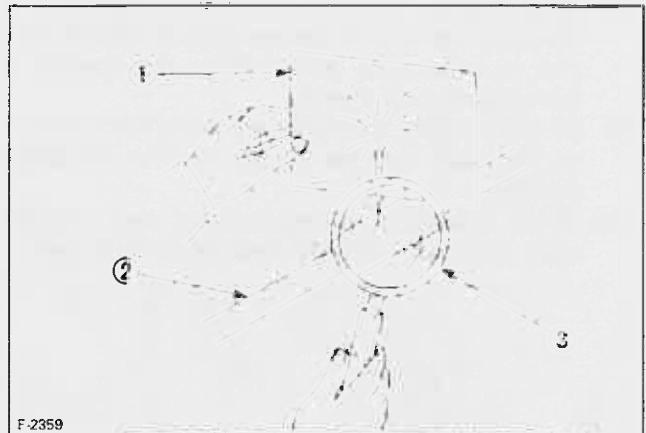

- ① Cardboard
- ② Hydraulic line
- ③ Magnifying glass

Fluid escaping from pinholes may be invisible. Do not use hands to search for suspected leaks; Use a piece of cardboard or wood, instead. Use of safety goggles or other eye protection is also highly recommended. If injured by escaping fluid, see a medical doctor at once. This fluid can produce gangrene or severe allergic reaction.

8. DANGER, WARNING AND CAUTION LABELS

① Part No. TA040-4965-2

	⚠ DANGER TA040-49652 ①
	<p>TO AVOID POSSIBLE INJURY OR DEATH FROM A MACHINE RUNAWAY.</p> <ol style="list-style-type: none"> 1. Do not start engine by shorting across starter terminals or bypassing the safety start switch. Machine may start in gear and move if normal starting circuitry is bypassed. 2. Start engine only from operator's seat with transmission and PTO OFF. Never start engine while standing on the ground.

② Part No. TA040-4932-2

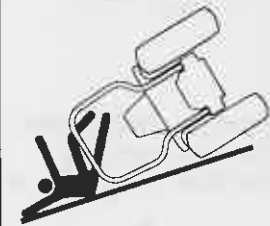
	⚠ WARNING TA040-49322 ②
	<p>TO AVOID PERSONAL INJURY OR DEATH FROM ROLL-OVER:</p> <ol style="list-style-type: none"> 1. Kubota recommends the use of a Roll-Over Protective Structures (ROPS) and seat belt in almost all applications. 2. Remove the ROPS only when it substantially interferes with operation or itself presents a safety risk. (Examples include work in orchards and vineyards.) ALWAYS REINSTALL IT BEFORE USING THE TRACTOR IN OTHER APPLICATIONS. 3. Never use just the seat belt or just the ROPS. They must be used together. For further details, consult your Operator's Manual or your local dealer.

③ Part No. TA040-4933-2



	⚠ WARNING TA040-49332 ③
	<p>BEFORE DISMOUNTING TRACTOR:</p> <ol style="list-style-type: none"> 1. PARK ON LEVEL GROUND WHENEVER POSSIBLE. If parking on a gradient, position tractor at right angles to the slope. 2. ALWAYS SET PARKING BRAKE. Leaving transmission in gear with the engine stopped will not prevent tractor from rolling. 3. LOWER ALL IMPLEMENTS TO THE GROUND. Failure to comply to this warning may allow the wheels to slip, and could cause injury or death. 4. LOCK SHUTTLE SHIFT LEVER IN NEUTRAL POSITION AND STOP THE ENGINE.

④ Part No. TA040-4959-2

	⚠ WARNING TA040-49592 ④
	<p>TO AVOID PERSONAL INJURY:</p> <ol style="list-style-type: none"> 1. Keep PTO shield in place at all times. 2. Before using PTO, set drawbar at 14 in. (356 mm) from drawbar pin hole to the end of PTO shaft. 3. Do not operate the PTO at speeds faster than the speed recommended by the implement manufacturer.

⑤ Part No. TA040-4956-1

Diesel fuel only No fire

	
TA040-49561	

⑥ Part No. TA040-4934-1
[with mid-PTO]

⚠ WARNING
<p>TO AVOID PERSONAL INJURY:</p> <p>Do not operate rear-PTO driven implements and mid-PTO driven implements at the same time.</p> <p style="text-align: right;">TA040-49341 ⑥</p>

⑦ Part No. TA040-4935-1

⚠ WARNING
<p>TO AVOID PERSONAL INJURY:</p> <ol style="list-style-type: none"> 1. Attach pulled or towed loads to the drawbar only. 2. Use the 3-point hitch only with equipment designed for 3-point hitch usage. <p style="text-align: right;">TA040-49351 ⑦</p>

⑧ Part No. 35080-6528-2

⚠ CAUTION
<p>Pull the engine stop knob back and hold it until the engine stops in case of emergency.</p> <p style="text-align: right;">35080-65282 ⑧</p>

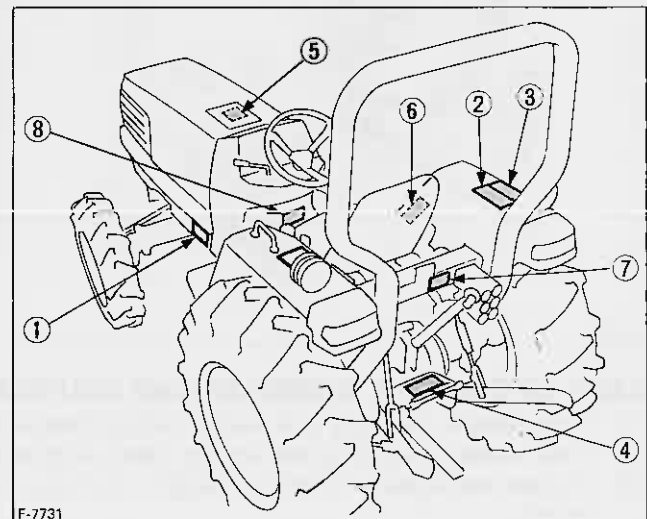

⑨ Part No. 35260-3491-3

CAUTION 35260-34913⑨

TO AVOID PERSONAL INJURY:

1. Read and understand the operator's manual before operation.
2. Before starting the engine, make sure that everyone is at a safe distance from the tractor and that the PTO is OFF.
3. Do not allow passengers on the tractor at any time.
4. Before allowing other people to use the tractor, have them read the operator's manual.
5. Check the tightness of all nuts and bolts regularly.
6. Keep all shields in place and stay away from all moving parts.
7. Lock the two brake pedals together before driving on the road.
8. Slow down for turns, or rough roads, or when applying individual brakes.
9. On public roads use SMV emblem and hazard lights, if required by local traffic and safety regulations.
10. Pull only from the drawbar.
11. Before dismounting, lower the implement, set the parking brake, stop the engine and remove the key.

⑪ Part No. TA040-4957-1
Stay clear of engine fan and fanbelt.

⑩ Part No. TA040-3015-1

<p>DANGER EXPLOSIVE GASES Cigarettes, flames or sparks could cause battery to explode. Always shield eyes and face from battery. Do not charge or use booster cables or adjust post connections without proper instruction and training. KEEP VENT CAPS TIGHT AND LEVEL.</p>	<p>POISON CAUSES SEVERE BURNS Contains sulfuric acid. Avoid contact with skin, eyes or clothing. In event of accident flush with water and call a physician immediately. KEEP OUT OF REACH OF CHILDREN <small>A34</small></p>
--	---

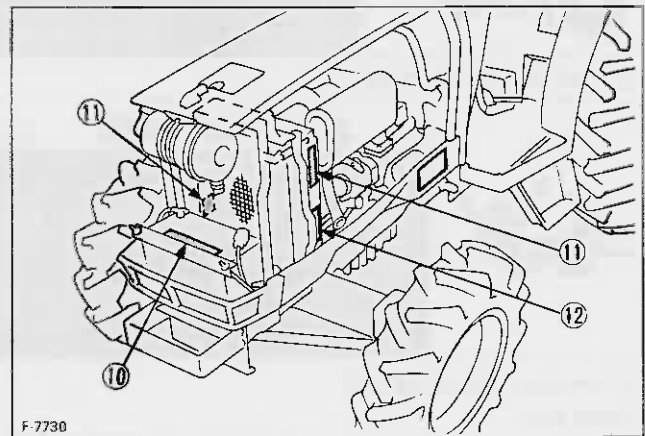
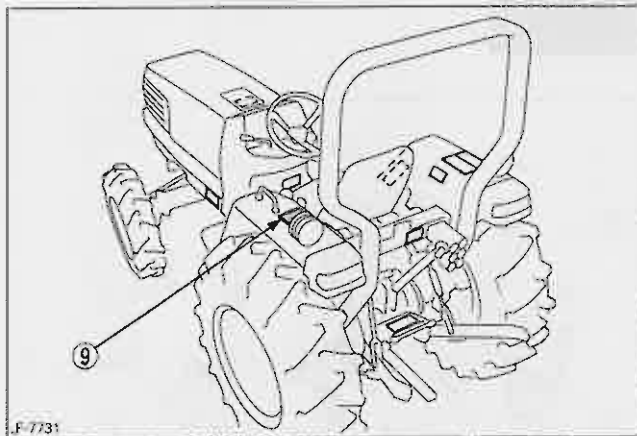
⑫ Part No. TA040-4958-1
Do not touch hot surface like muffler, etc.**CARE OF DANGER, WARNING AND CAUTION LABELS**

- (1) Keep danger, warning and caution labels clean and free from obstructing material.
- (2) Clean danger, warning and caution labels with soap and water, dry with a soft cloth.
- (3) Replace damaged or missing danger, warning and caution labels with new labels from your local KUBOTA dealer.
- (4) If a component with danger, warning and caution label (s) affixed is replaced with new part, make sure new label (s) is (are) attached in the same location (s) as the replaced component.
- (5) Mount new danger, warning and caution labels by applying on a clean dry surface and pressing any bubbles to outside edge.

SERVICING OF TRACTOR

Your dealer is interested in your new tractor and has the desire to help you get the most value from it. After reading this manual thoroughly, you will find that you can do some of the regular maintenance yourself. However, when in need of parts or major service, be sure to see your KUBOTA dealer.

For service, contact the KUBOTA Dealership from which you purchased your tractor or your local KUBOTA dealer.

When in need of parts, be prepared to give your dealer both the tractor and engine serial numbers. Locate the serial numbers now and record them in the space provided.

	Type	Serial No.
Tractor	<u>3300D</u>	<u>5067</u>
Engine	<u>1703-A</u>	
Date of Purchase	_____	
Name of Dealer	_____	
	(To be filled in by purchaser)	
	<u>Eng. 1703-A2-37</u>	

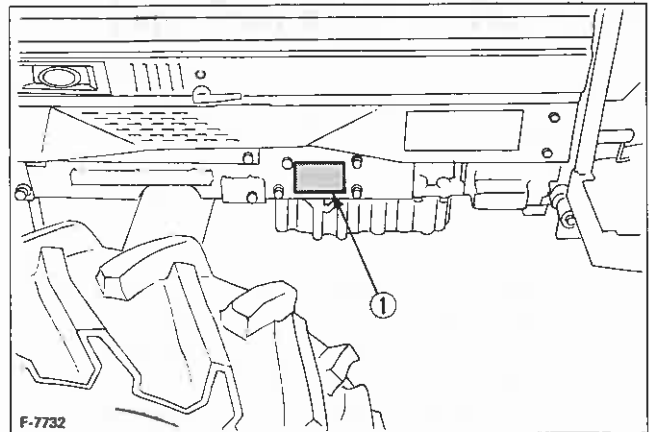

① Tractor identification plate

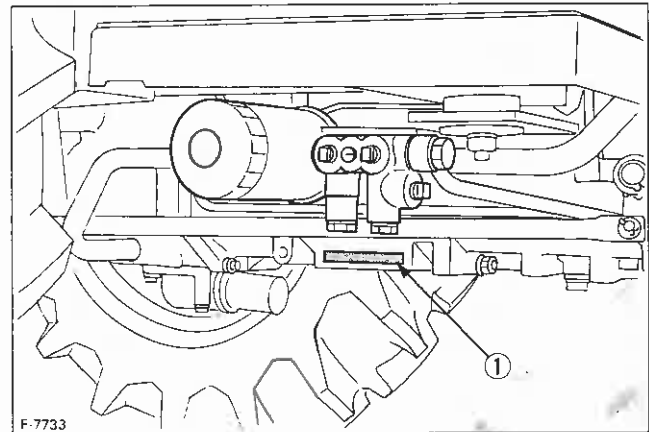

① Tractor serial number

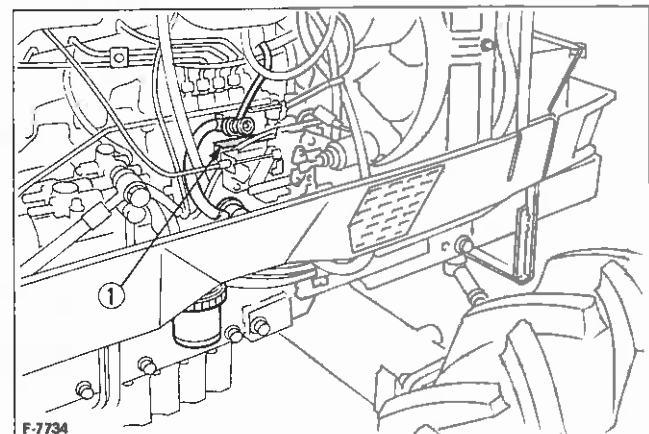

① Engine serial number

SPECIFICATIONS

SPECIFICATION TABLE (GST Type)

Model		L2900GST		L3300GST		L3600GST		L4200GST					
		4WD		4WD		4WD		2WD	4WD				
PTO power		kW (HP)		18.7 (25.0)*		20.9 (28.0)*		23.1 (31.0)*		27.6 (37.0)*			
Maker		KUBOTA											
Model		D1503-L-A		D1703-A		V1903-A		V2203-A					
Type		Indirect Injection Vertical, water-cooled, 4-cycle diesel											
Number of cylinders		3					4						
Bore and stroke		mm (in.)		83×92.4 (3.3×3.6)		87×92.4 (3.4×3.6)		80×92.4 (3.1×3.6)		87×92.4 (3.4×3.6)			
Total displacement		cm ³ (cu. in.)		1499 (91.5)		1647 (100.5)		1857 (113.3)		2197 (134.1)			
Engine gross power		kW (HP)		23.9 (32.1)*		26.2 (35.1)*		28.7 (38.5)*		33.8 (45.3)*			
Rated revolution		r/s (rpm)		45.0 (2700)				43.3 (2600)					
Maximum torque		kgf·m (ft·lb)		9.8 (70.9)		10.8 (77.9)		12.3 (88.7)		14.2 (102.9)			
Battery		12V, RC:123 min, CCA:490A					12V, RC:137 min, CCA:447A						
Fuel		Diesel fuel No.1 [below -10°C (14°F)] Diesel fuel No.2 [above -10°C (14°F)]											
Fuel tank		ℓ (U.S. gals.)		35.0 (9.2)									
Engine crankcase (with filter)		ℓ (U.S. qts.)		3.5 (3.7)				6.0 (6.3)					
Engine coolant		ℓ (U.S. qts.)		7.0 (7.4)				7.5 (7.9)					
Transmission case		ℓ (U.S. gals.)		39.0 (10.3)									
Overall length (without 3p)		mm (in.)		2820 (111.0)		2850 (112.2)		3000 (118.1)		3020 (118.9)			
Overall width (min. tread)		mm (in.)		1325 (52.2)		1355 (53.3)		1425 (56.1)		1585 (62.4)			
Overall height (with ROPS)		mm (in.)		2090 (82.3)		2130 (83.9)		2120 (83.5)		2145 (84.4)			
Overall height (Top of steering wheel)		mm (in.)		1515 (59.6)		1530 (60.2)		1525 (60.0)		1535 (60.4)			
Wheel base		mm (in.)		1670 (65.7)				1805 (71.1)		1810 (71.3) 1805 (71.1)			
Min. ground clearance		mm (in.)		325 (12.8)		350 (13.8)		335 (13.2)		370 (14.6)			
Tread		Front		mm (in.)				1105 (43.5)		1155 (45.5)			
		Rear		mm (in.)				1080 (42.5), 1180 (46.4)		1145 (45.1), 1245 (49.0), 1345 (53.0), 1445 (56.9)			
Weight (with ROPS)		kg (lbs.)		1235 (2720)		1260 (2775)		1345 (2965)		1375 (3030) 1380 (3040)			
Clutch		Dry type single stage											
Tires		Front		7.2-16				8.3-16		6.00-16 8.3-16			
		Rear		11.2-24		12.4-24		13.6-24		14.9-24			
Steering		Hydrostatic power steering											
Transmission		Glide shift transmission (8 forward and 8 reverse speeds)											
Brake		Wet disk type											
Min. turning radius (with brake)		m (feet)		2.5 (8.2)				2.6 (8.5)		2.5 (8.2) 2.6 (8.5)			
Hydraulic control system		Position control											
Pump capacity		ℓ/min (gals/min)		26.4 (7.0)				29.5 (7.8)					
Three point hitch		SAE Category I											
Max. lift force		At lift points		kg (lbs.)								1300 (2870)	
		24in. behind lift points		kg (lbs.)				1000 (2200)				1050 (2310)	
System pressure		kgf/cm ² (psi.)		175 (2490)									
Rear PTO		SAE 1-3/8, 6 splines (with overrunning clutch)											
MID-PTO (if equipped)		Revolution		1 speed: 9.0 r/s (540rpm)/ engine 44.5 r/s (2670rpm)				1 speed: 9.0 r/s (540rpm)/ engine 40.8 r/s (2447rpm)					
		Revolution		1 speed: 33.3 r/s (2000rpm)/ engine 43.7 r/s (2623rpm)				1 speed: 33.3 r/s (2000rpm)/ engine 40.1 r/s (2404rpm)					

NOTE: * Manufacturer's estimate The company reserves the right to change the specifications without notice.







SPECIFICATION TABLE (Manual Transmission Type)

Model	L2900		L3300		L3600		L4200				
	2WD	4WD	2WD	4WD	2WD	4WD	2WD	4WD			
PTO power	kW (HP)		18.7 (25.0)*		20.9 (28.0)*		23.1 (31.0)*		27.6 (37.0)*		
Maker	KUBOTA										
Model	D1503-L-A		D1703-A		V1903-A		V2203-A				
Type	Indirect Injection Vertical, water-cooled, 4-cycle diesel										
Number of cylinders	3				4						
Bore and stroke	mm (in.)		83×92.4 (3.3×3.6)		87×92.4 (3.4×3.6)		80×92.4 (3.1×3.6)		87×92.4 (3.4×3.6)		
Total displacement	cm ³ (cu. in.)		1499 (91.5)		1647 (100.5)		1857 (113.3)		2197 (134.1)		
Engine gross power	kW (HP)		23.9 (32.1)*		26.2 (35.1)*		28.7 (38.5)*		33.8 (45.3)*		
Rated revolution	r/s (rpm)		45.0 (2700)				43.3 (2600)				
Maximum torque	kgf-m (ft-lb)		9.8 (70.9)		10.8 (77.9)		12.3 (88.7)		14.2 (102.9)		
Battery	12V, RC:123min, CCA:490A				12V, RC:137min, CCA:447A						
Fuel	Diesel fuel No.1 [below -10°C (14°F)] Diesel fuel No.2 [above -10°C (14°F)]										
Fuel tank	ℓ (U.S.gals.)		35.0 (9.2)								
Engine crankcase (with filter)	ℓ (U.S.qts.)		3.5 (3.7)				6.0 (6.3)				
Engine coolant	ℓ (U.S.qts.)		7.0 (7.4)				7.5 (7.9)				
Transmission case	ℓ (U.S.gals.)		39.0 (10.3)								
Overall length (without 3p)	mm (in.)		2820 (111.0)		2850 (112.2)		3000 (118.1)		3020 (118.9)		
Overall width (min. tread)	mm (in.)		1325 (52.2)		1355 (53.3)		1425 (56.1)		1585 (62.4)		
Overall height (with ROPS)	mm (in.)		2090 (82.3)		2130 (83.9)		2120 (83.5)		2145 (84.4)		
Overall height (Top of steering wheel)	mm (in.)		1515 (59.6)		1530 (60.2)		1525 (60.0)		1535 (60.4)		
Wheel base	mm (in.)		1675 (65.9)	1670 (65.7)	1675 (65.9)	1670 (65.7)	1810 (71.3)	1805 (71.1)	1810 (71.3)	1805 (71.1)	
Min. ground clearance	mm (in.)		325 (12.8)		350 (13.8)		335 (13.2)		370 (14.6)		
Tread	Front	mm (in.)		960 (37.8)	1105 (43.5)	960 (37.8)	1105 (43.5)	1145 (45.1)	1155 (45.5)	1145 (45.1)	
		mm (in.)		1060 (41.7)		1060 (41.7)		1245 (49.0)		1245 (49.0)	
Rear	mm (in.)	1160 (45.7)		1160 (45.7)		1160 (45.7)		1345 (53.0)		1345 (53.0)	
		1260 (49.6)		1260 (49.6)		1260 (49.6)		1445 (56.9)		1445 (56.9)	
Weight (with ROPS)	kg (lbs.)	1035 (40.7), 1120 (44.1)		1035 (40.7), 1120 (44.1)		1080 (42.5), 1180 (46.4)		1080 (42.5), 1180 (46.4)		1180 (46.5), 1200 (47.2)	
		1220 (48.0), 1305 (51.4)		1220 (48.0), 1305 (51.4)		1200 (47.2), 1300 (51.2)		1200 (47.2), 1300 (51.2)		1300 (51.2), 1450 (57.1)	
1405 (55.3)	mm (in.)	1405 (55.3)		1405 (55.3)		1450 (57.1), 1545 (60.8)		1450 (57.1), 1545 (60.8)		1545 (60.8)	
		1160 (2560)		1230 (2710)		1185 (2610)		1255 (2765)		1270 (2800)	
Clutch		Dry type single stage									
Tires	Front	5.00-15		7.2-16		5.00-15		7.2-16		6.00-16	
	Rear	11.2-24		12.4-24		13.6-24		14.9-24			
Steering		Hydrostatic power steering									
Transmission		Synchronized shuttle and synchronized transmission (8 forward and 8 reverse speeds)									
Brake		Wet disk type									
Min. turning radius (with brake)		m (feet)		2.4 (7.9)	2.3 (7.5)	2.4 (7.9)	2.3 (7.5)	2.5 (8.2)	2.5 (8.2)	2.5 (8.2)	2.5 (8.2)
Hydraulic control system		Position control									
Pump capacity		ℓ/min (gals/min)				26.4 (7.0)		29.5 (7.8)			
Three point hitch		SAE Category I									
Max. lift force	At lift points	kg (lbs.)									
	24in. behind lift points	1000 (2200)				1050 (2310)					
System pressure		kgf/cm ² (psi)									
Rear PTO		SAE 1-3/8, 6 splines (with overrunning clutch)									
Revolution	1 speed: 9.0 r/s (540rpm)/ engine 44.5 r/s (2670rpm)				1 speed: 9.0 r/s (540rpm)/ engine 40.8 r/s (2447rpm)						
	MID-PTO (if equipped)		USA No.5 (KUBOTA 10-tooth) involute spline						—		
Revolution	1 speed: 33.3 r/s (2000rpm)/ engine 43.7 r/s (2623rpm)				1 speed: 33.3 r/s (2000rpm)/ engine 40.1 r/s (2404rpm)						

NOTE: * Manufacturer's estimate The company reserves the right to change the specifications without notice.

TRAVELING SPEEDS

(At rated engine rpm)

Model				L2900-L3300				L3600-L4200				
Tire size (Rear)				11.2-24		12.4-24		13.6-24		14.9-24		
Shuttle shift lever	GST Type		Manual Transmission Type		km/h	mph	km/h	mph	km/h	mph	km/h	mph
	Main gear shift lever	Range gear shift lever	Main gear shift lever	Main gear shift lever								
Forward 	1	Low 	1	1.5	0.9	1.6	1.0	1.4	0.9	1.5	0.9	
	2		2	2.1	1.3	2.3	1.4	2.0	1.2	2.1	1.3	
	3		3	3.5	2.2	3.7	2.3	3.2	2.0	3.3	2.1	
	4		4	5.1	3.2	5.5	3.4	4.8	3.0	4.9	3.0	
	5	High 	1	7.3	4.5	7.7	4.8	6.8	4.2	7.0	4.3	
	6		2	10.3	6.4	11.0	6.8	9.6	6.0	9.9	6.2	
	7		3	16.7	10.4	17.8	11.1	15.6	9.7	16.1	10.0	
	8		4	24.7	15.3	26.3	16.3	23.0	14.3	23.7	14.7	
Reverse 	1	Low 	1	1.4	0.8	1.5	0.9	1.3	0.8	1.3	0.8	
	2		2	2.0	1.2	2.1	1.3	1.8	1.1	1.9	1.2	
	3		3	3.2	2.0	3.4	2.1	3.0	1.9	3.1	1.9	
	4		4	4.7	2.9	5.0	3.1	4.4	2.7	4.5	2.8	
	5	High 	1	6.7	4.2	7.1	4.4	6.2	3.9	6.4	4.0	
	6		2	9.5	5.9	10.0	6.2	8.8	5.5	9.1	5.7	
	7		3	15.3	9.5	16.3	10.1	14.3	8.9	14.7	9.1	
	8		4	22.7	14.1	24.1	15.0	21.1	13.1	21.8	13.5	

The company reserves the right to change the specifications without notice.

IMPLEMENT LIMITATIONS

The KUBOTA Tractor has been thoroughly tested for proper performance with implements sold or approved by KUBOTA. Use with implements which exceed the maximum specifications listed below, or which are otherwise unfit for use with the KUBOTA Tractor may result in malfunctions or failures of the tractor, damage to other property and injury to the operator or others. [Any malfunctions or failures of the tractor resulting from use with improper implements are not covered by the warranty.]

	Tread (max. width) with farm tires			Lower link end max. lifting capacity W_0
	Front		Rear	
	2WD	4WD		
L2900	1260 mm (49.6 in.)	1105 mm (43.5 in.)	1405 mm (55.3 in.)	1300 kg (2870 lbs.)
L3300				
L3600	1445 mm (56.9 in.)	1155 mm (45.5 in.)	1545 mm (60.8 in.)	
L4200		1180 mm (46.5 in.)		

	Actual figures		
	Implement weight W_1 and/or size	Max. Drawbar Load W_2	Trailer loading weight W_3 Max. capacity
L2900	As in the following list (Shown on the next page)	500 kg (1100 lbs.)	1500 kg (3300 lbs.)
L3300		650 kg (1430 lbs.)	2000 kg (4400 lbs.)
L3600			2500 kg (5500 lbs.)
L4200			3000 kg (6600 lbs.)

Lower link end max. hydraulic lifting capacity W_0

Implement weightThe implement's weight which can be put on the lower link: W_1

Max. drawbar load W_2

Trailer loading weightThe max. loading weight for trailer (without trailer's weight): W_3

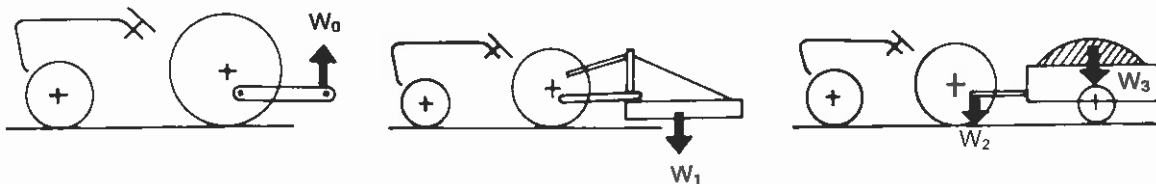

NOTE:

- Implement size may vary depending on soil operating conditions.

No.	Implement	Remarks	L2900	L3300	L3600	L4200	
1	Trailer	Max. load capacity kg (lbs.)	1500 (3300)	2000 (4400)	2500 (5500)	2500 (5500)	
		Max. drawbar load kg (lbs.)	500 (1100)	500 (1100)	650 (1430)	650 (1430)	
2	Mid-Mount	Max. cutting width mm (in.)	1829 (72)	1829 (72)	1829 (72)	—	
		Max. weight kg (lbs.)	200 (440)	200 (400)	200 (440)	—	
		Rotary-Cutter	Max. cutting width mm (in.)	1829 (72)	1829 (72)	1829 (72)	1829 (72)
			Max. weight kg (lbs.)	350 (770)	350 (770)	400 (880)	400 (880)
	Flail Mower	Max. cutting width mm (in.)	1524 (60)	1524 (60)	1524 (60)	1524 (60)	
		Max. weight kg (lbs.)	400 (880)	400 (880)	400 (880)	400 (880)	
	Sickle Bar	Max. cutting width mm (in.)	2133 (84)	2133 (80)	2133 (80)	2133 (84)	
		Max. weight kg (lbs.)	500 (1100)	500 (1100)	500 (1100)	500 (1100)	
3	Sprayer	Rear mounted Max. tank capacity ℓ (gals.)	300 (80)	300 (86)	400 (106)	400 (106)	
		Pull type Max. tank capacity ℓ (gals.)	800 (210)	1000 (265)	1200 (317)	1200 (317)	
4	Rotary Tiller	Max. tilling width mm (in.)	1520 (60)	1520 (60)	1520 (60)	1520 (60)	
5	Bottom Plow	Max. size	12 in.X2 16 in.X1	12 in.X2 16 in.X1	14 in.X2	14 in.X2	
6	Disk harrow: Pull type	Max. harrowing width mm (in.)	1829 (72)	1829 (72)	1981 (78)	1981 (78)	
		Max. weight kg (lbs.)	350 (770)	350 (770)	400 (880)	400 (880)	
7	Chisel Plow	Max. width mm (in.)	1829 (72)	1829 (72)	1829 (72)	1829 (72)	
		Max. weight kg (lbs.)	350 (770)	350 (770)	350 (770)	350 (770)	
8	Broad Caster	Max. tank capacity ℓ (gals.)	200 (53)	250 (53)	300 (80)	300 (80)	
		Max. weight kg (lbs.)	100 (220)	100 (220)	100 (220)	100 (220)	
9	Manure Spreader	Max. capacity kg (lbs.)	1500 (3300)	1500 (3300)	2000 (4400)	2000 (4400)	
10	Cultivator	Max. width mm (in.)	1829 (72)	1829 (72)	2134 (84)	2134 (84)	
		Number of rows	1	1	2	2	
		Max. weight kg (lbs.)	300 (660)	350 (770)	400 (880)	400 (880)	
11	Front Blade	Max. cutting width mm (in.)	1829 (72)	1829 (72)	1829 (72)	1829 (72)	
		Max. oil pressure kgf/cm ² (psi)	175 (2490)	175 (2490)	175 (2490)	175 (2490)	
		Sub frame	Necessary	Necessary	Necessary	Necessary	
12	Rear Blade	Max. cutting width mm (in.)	1829 (72)	1829 (72)	1829 (72)	1829 (72)	
		Max. oil pressure kgf/cm ² (psi)	175 (2490)	175 (2490)	175 (2490)	175 (2490)	
13	Front-end Loader	Max. lifting capacity kg (lbs.)	480 (1060)	480 (1060)	680 (1500)	680 (1500)	
		Max. oil pressure kgf/cm ² (psi)	175 (2490)	175 (2490)	175 (2490)	175 (2490)	
		Sub frame	Necessary	Necessary	Necessary	Necessary	
14	Box Blade	Max. cutting wigth mm (in.)	1321 (52)	1321 (52)	1651 (65)	1670 (66)	
		Max. weight kg (lbs.)	295 (650)	295 (650)	350 (770)	350 (770)	
15	Back Hoe	Max. digging depth mm (in.)	2288 (90)	2288 (90)	2288 (90)	2288 (90)	
		Max. weight kg (lbs.)	450 (990)	450 (990)	450 (990)	450 (990)	
		Sub frame	Necessary	Necessary	Necessary	Necessary	
16	Snow Blade	Max. width mm (in.)	1524 (60)	1524 (60)	1524 (60)	1830 (72)	
		Max. weight kg (lbs.)	300 (660)	300 (660)	350 (770)	350 (770)	
17	Snow Blower	Max. working width mm (in.)	1524 (66)	1524 (60)	1676 (66)	1676 (66)	
		Max. weight kg (lbs.)	250 (550)	250 (550)	280 (620)	280 (620)	

NOTE:

- Implement size may vary depending on soil operating conditions.

INSTRUMENT PANEL AND CONTROLS

■ Instrument Panel, Switches and Hand Controls

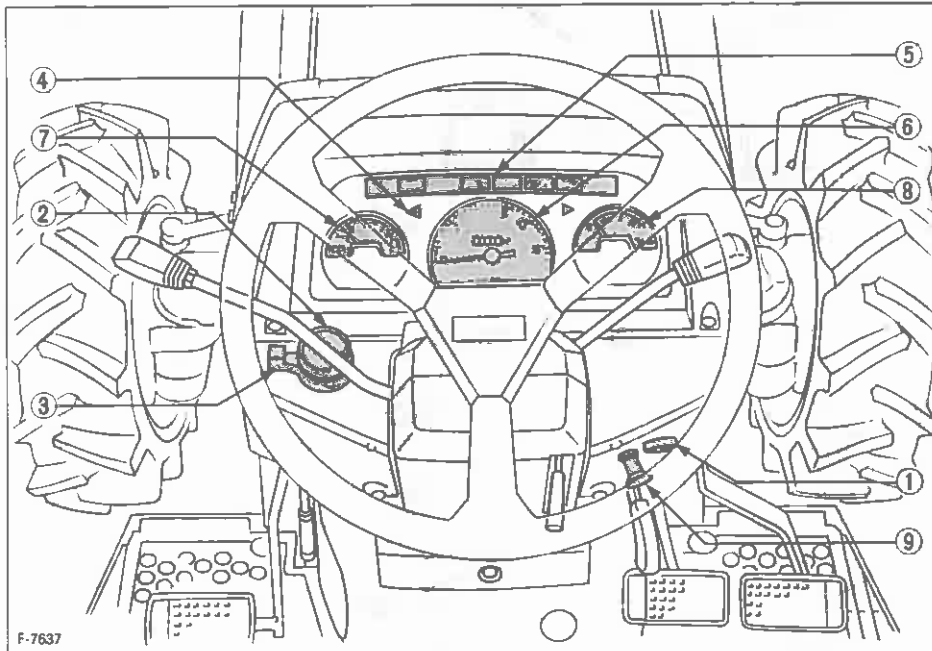

F-7637

ILLUSTRATED CONTENTS

① Key switch	18
② Head light switch	22
③ Hazard light switch	22
④ Hazard light indicator	22
⑤ Easy Checker™	18, 19, 29
⑥ Hourmeter / Tachometer	30
⑦ Fuel gauge	29
⑧ Coolant temperature gauge	30
⑨ Engine stop knob	19

Foot and Hand Controls

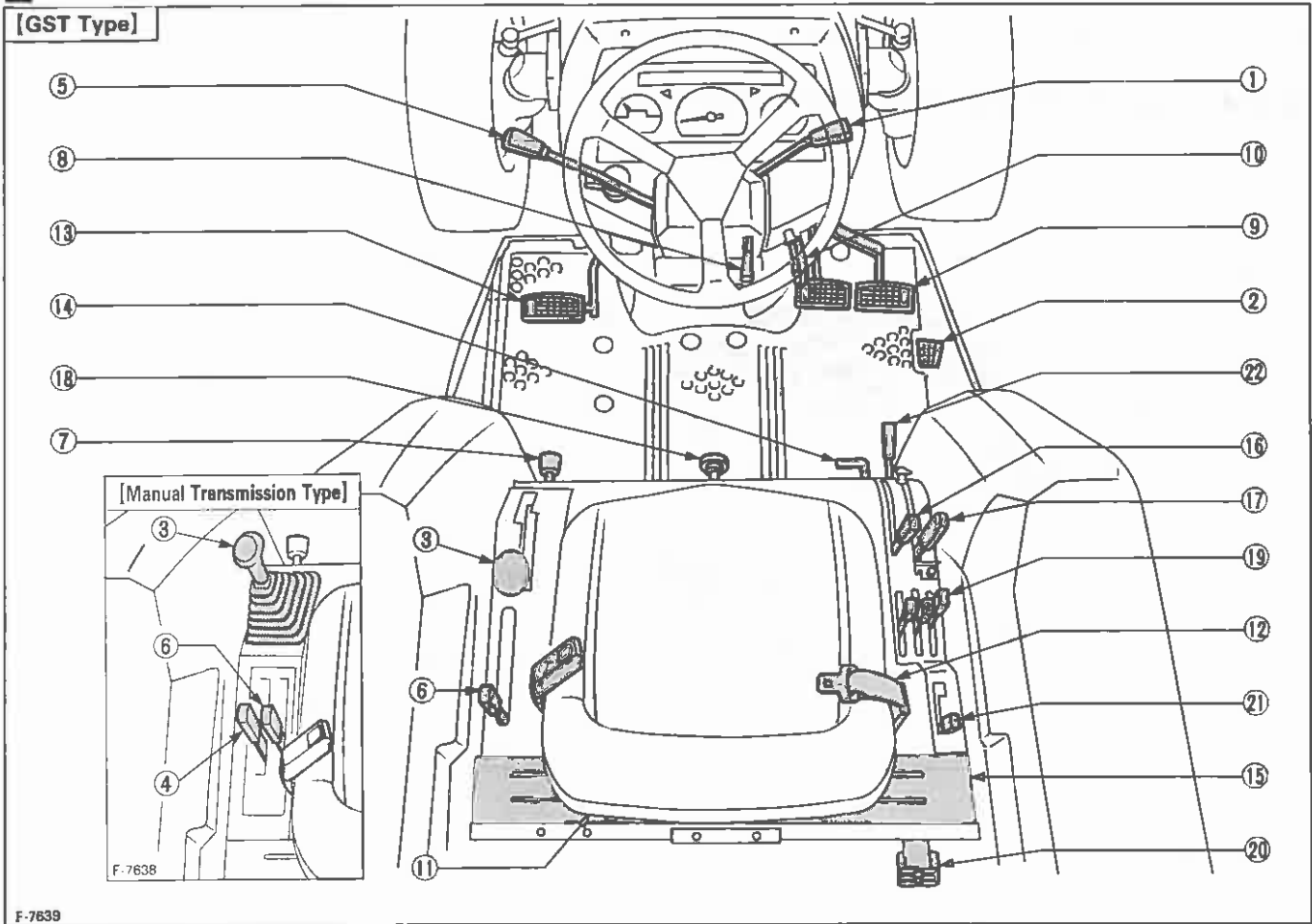

ILLUSTRATED CONTENTS

① Hand throttle lever	18,28
② Foot throttle	18,28
③ Main gear shift lever	17,24,26
④ Range gear shift lever (Hi-Lo) 【Manual Transmission Type】	26
⑤ Shuttle shift lever 【GST Type】/ Synchro-shuttle shift lever 【Manual Transmission Type】	17,24,26
⑥ Creep gear shift lever (if equipped)	27
⑦ Front wheel drive lever	27
⑧ Steering wheel tilt lever	22
⑨ Brake pedal	23
⑩ Parking brake lever	16,28
⑪ Operator's seat	21

ILLUSTRATED CONTENTS

⑫ Seat belt	22
⑬ Clutch pedal	23
⑭ Differential lock pedal	30
⑮ Tool-box	—
⑯ Draft control lever (if equipped)	17,37
⑰ Position control lever	17,37
⑱ 3-Point hitch lowering speed knob	38
⑲ Remote control valve lever (if equipped)	40
⑳ Remote control valve coupler (if equipped)	40
㉑ PTO gear shift lever 【Without independent PTO type】 / PTO clutch control lever 【With independent PTO type】	17,32
㉒ Mid -PTO lever (if equipped)	33

PRE-OPERATION CHECK

DAILY CHECK

To prevent trouble from occurring, it is important to know the conditions of the tractor well. Check it before starting.



CAUTION

To avoid personal injury:

- Be sure to check and service the tractor on a level surface with the engine shut off and the parking brake "ON".

Check item

- Walk around inspection
- Check engine oil level
- Check transmission oil level
- Check coolant level
- Clean grill and radiator screen
- Check air cleaner evacuator valve
(When used in a dusty place)
- Check brake and clutch pedal
- Check indicators, gauges and meter
- Check lights
- Check seat belt and ROPS
- Refuel
(See "DAILY CHECK" in periodic service section.)
- Care of danger, warning and caution labels
(See "DANGER, WARNING AND CAUTION LABELS" in safe operation section.)

OPERATING THE ENGINE



CAUTION

To avoid personal injury:

- Read "Safe Operation" in the front of this manual.
- Read the danger, warning and caution labels located on the tractor.
- To avoid the danger of exhaust fume poisoning, do not operate the engine in a closed building without proper ventilation.
- Never start engine while standing on ground. Start engine only from operator's seat.

IMPORTANT:

- Do not use starting fluid or ether.
- When starting the engine after long storage (of more than three months), first pull the engine stop knob and then activate the starter for about ten seconds to allow oil to reach every engine part.
- To protect the battery and the starter, make sure that the starter is not continuously turned for more than 30 seconds.

STARTING THE ENGINE

1. Set the parking brake

- (1) To set the parking brake;
 - 1) Interlock the brake pedals.
 - 2) Depress the brake pedals.
 - 3) Latch the brake pedals with the parking brake lever.
- (2) To release the parking brake, depress the brake pedals again.

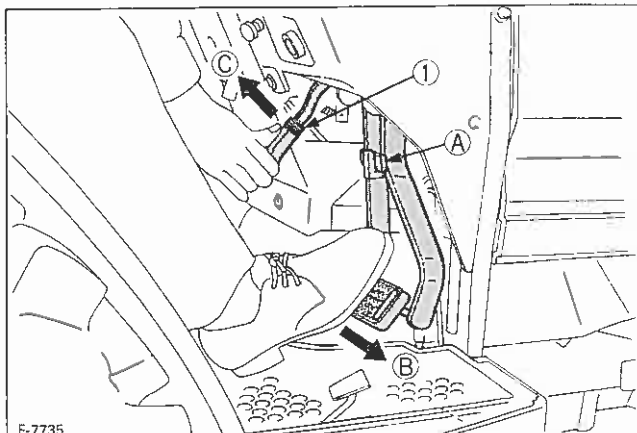

- ① Parking brake lever A Interlock the brake pedals
 B "DEPRESS"
 C "PULL"

2. Make sure the fuel cock is in the "OPEN" position.

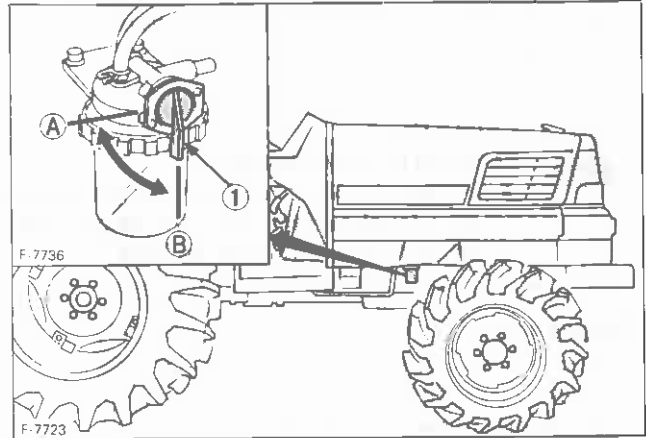

- ① Fuel cock A "CLOSE"
 B "OPEN"

3. Make sure the engine stop knob is pushed in.

Push in the engine stop knob if it is pulled out, or the engine will not start.

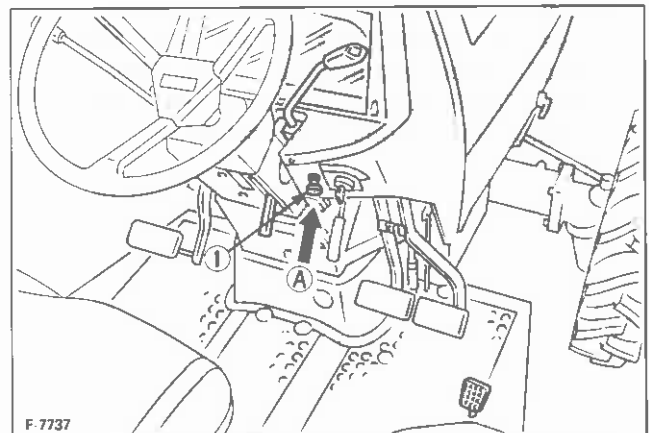

- ① Engine stop knob A "PUSH"

OPERATING THE ENGINE



CAUTION

To avoid personal injury:

- Read "Safe Operation" in the front of this manual.
- Read the danger, warning and caution labels located on the tractor.
- To avoid the danger of exhaust fume poisoning, do not operate the engine in a closed building without proper ventilation.
- Never start engine while standing on ground. Start engine only from operator's seat.

IMPORTANT:

- Do not use starting fluid or ether.
- When starting the engine after long storage (of more than three months), first pull the engine stop knob and then activate the starter for about ten seconds to allow oil to reach every engine part.
- To protect the battery and the starter, make sure that the starter is not continuously turned for more than 30 seconds.

STARTING THE ENGINE

1. Set the parking brake

- (1) To set the parking brake;
 - 1) Interlock the brake pedals.
 - 2) Depress the brake pedals.
 - 3) Latch the brake pedals with the parking brake lever.
- (2) To release the parking brake, depress the brake pedals again.

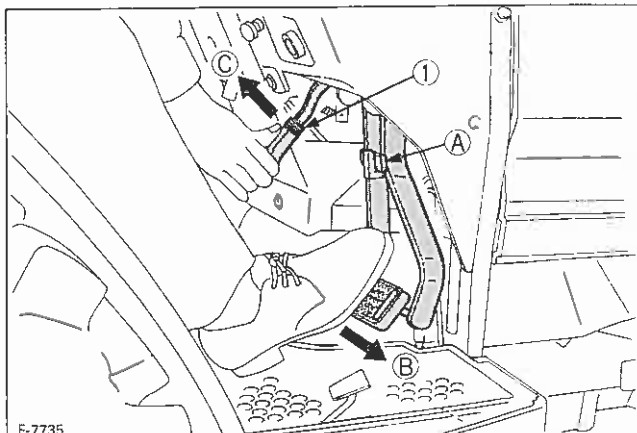

- ① Parking brake lever ① Interlock the brake pedals
 ② "DEPRESS"
 ③ "PULL"

2. Make sure the fuel cock is in the "OPEN" position.

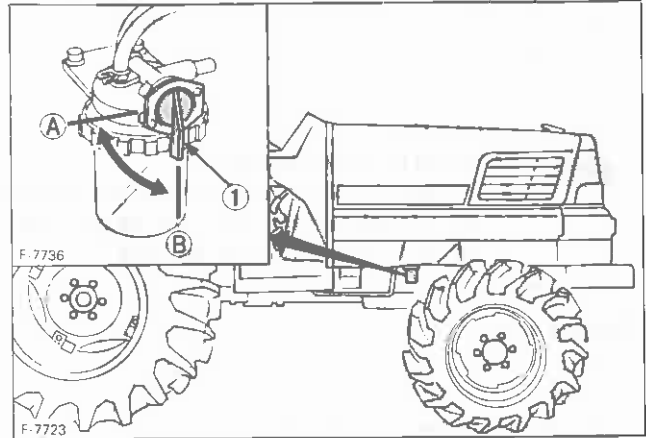

- ① Fuel cock ① "CLOSE"
 ② "OPEN"

3. Make sure the engine stop knob is pushed in.

Push in the engine stop knob if it is pulled out, or the engine will not start.

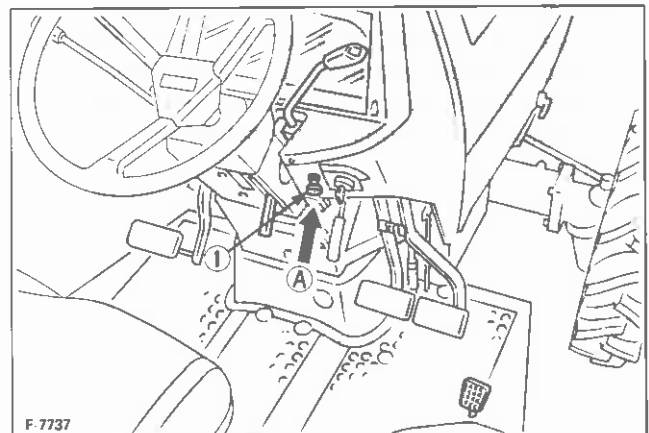

- ① Engine stop knob ① "PUSH"

7. Set the throttle lever to about 1/2 way.

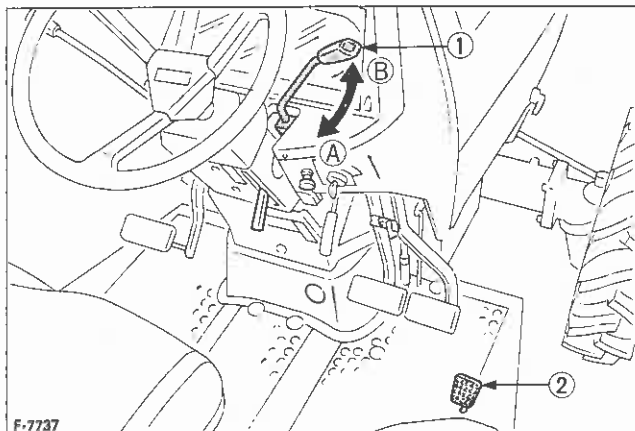

- ① Hand throttle lever
- ② Foot throttle
- A "INCREASE"
- B "DECREASE"

8. Insert the key into the key switch and turn it "ON".

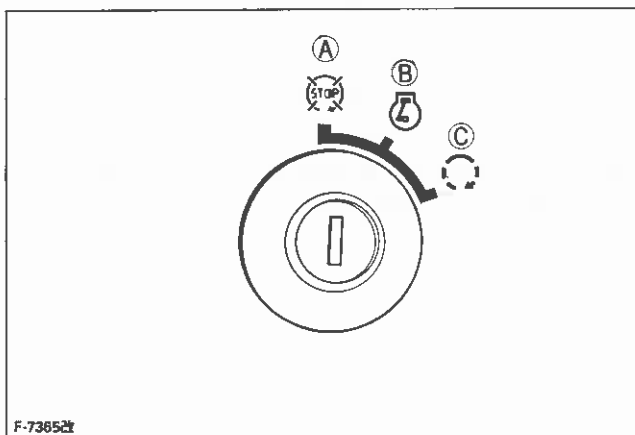

- A "OFF"
- B "ON"
- C "START"

◆ Check Easy Checker™ lamps:

- (1) When the key is turned "ON", ③ ④ ⑤ lamps should come on. If trouble should occur at any location while the engine is running, the warning lamp corresponding to that location comes on.
- (2) Glow plug indicator ⑥ comes "ON" while engine is being preheated and goes off automatically when preheat is completed. Illuminating time of indicator varies according to the temperature of cooling water.
- (3) The parking brake warning lamp ⑦ comes "ON" while parking brake is applied and goes off when released it.

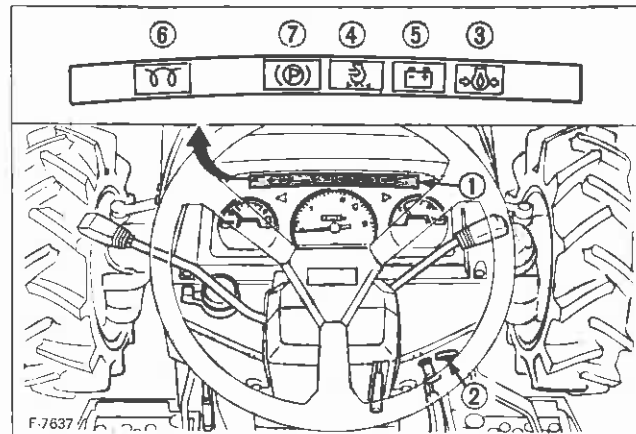

- ① Easy checker™
- ② Key switch
- ③ Engine oil pressure
- ④ Air cleaner
- ⑤ Electrical charge
- ⑥ Glow plug indicator
- ⑦ Parking brake

IMPORTANT:

- Daily checks with the Easy Checker™ only, are not sufficient. Never fail to conduct daily checks carefully by referring to Daily Check. (See "DAILY CHECK" in Periodic Service Section)

9. Fully depress the clutch pedal.

10. Turn the key to "START" position and release when the engine starts.

IMPORTANT:

[Without independent PTO type]

- Because of the safety device, the engine will not start except when the PTO gear shift lever placed in the "OFF" position and shuttle shift lever placed in the "NEUTRAL" position.

[With independent PTO type]

- Because of the safety device, the engine will not start except when the PTO clutch control lever placed in the "OFF" position and shuttle shift lever placed in the "NEUTRAL" position.

11. Check to see that all the lamps on the Easy Checker™ are "OFF".

If the lamp is still on, immediately stop the engine and determine the cause.

12. Release the clutch pedal.

COLD WEATHER STARTING

If the ambient temperature is below -5°C (23°F) and the engine is very cold, start it in the following manner:

Take steps (1) through (9) above.

- 10. Turn the key to "ON" (glow plug) and keep it there until glow plug indicator goes off.**

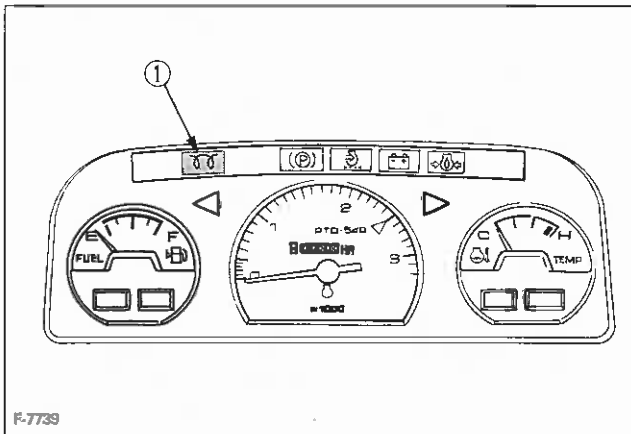

① Glow plug indicator

- 11. Turn the key to the start position and the engine should start.**

(If the engine fails to start after 10 seconds, turn off the key for 30 seconds. Then repeat steps (10) and (11). To protect the battery and the starter, make sure that the starter is not continuously turned for more than 30 seconds.)

■ Block Heater (Option)

A block heater is available as an option from your dealer. It will assist you in starting your tractor when the ambient temperature is below -20°C (-4°F).

STOPPING THE ENGINE

- 1. After slowing the engine to idle, turn the key to "OFF".**
- 2. Remove the key.**

■ Engine Stop Knob



CAUTION

To avoid personal injury:

- Pull the engine stop knob back and hold it until the engine stops in case of emergency.

The engine stops when the key is turned OFF.

If the engine does not stop, pull the engine stop knob back and hold it until the engine stops.

After the engine has stopped, be sure to push the engine stop knob back in, or the engine will not start next time.

NOTE:

- If key does not stop the engine, consult your local KUBOTA dealer.

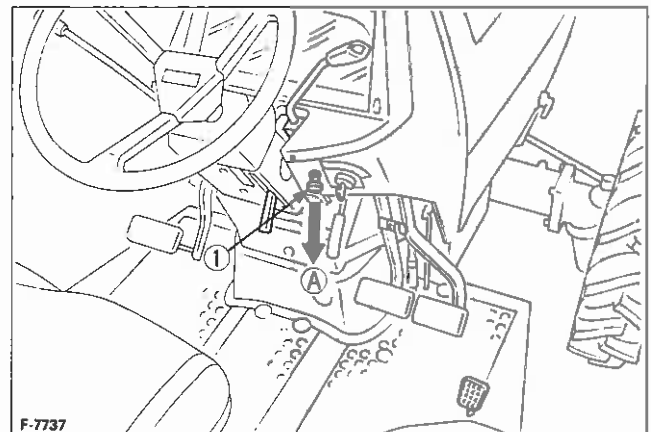

① Engine stop knob

Ⓐ Pull to "STOP"

WARMING UP



CAUTION

To avoid personal injury:

- Be sure to set the parking brake during warm-up.

For five minutes after engine start-up, allow engine to warm up without applying any load, this is to allow oil to reach every engine part. If load should be applied to the engine without this warm-up period, trouble such as seizure, breakage or premature wear may develop.

Warm-up and Transmission Oil in the Low Temperature Range

◆ GST type

A tractor with GST utilizes a hydraulic clutch. Hydraulic oil serves as transmission oil, and power steering. In cold weather, the oil may be cold with increased viscosity. This can cause delayed oil circulation or abnormally low hydraulic pressure for some time after engine start-up. This in turn can result in trouble in the hydraulic system or damage to the power steering or hydraulic clutch.

To prevent the above, observe the following instructions:

Warm up the engine at about 50 % of rated rpm according to the table below:

Ambient temperature	Warm-up time requirement
Above 0°C (32°F)	At least 10 minutes
0 to -10°C (32 to 14°F)	10 to 20 minutes
-10 to -20°C (14 to -4°F)	20 to 30 minutes
Below -20°C (-4°F)	More than 30 minutes

IMPORTANT:

- Do not operate the tractor under full load condition until it is sufficiently warmed up.

JUMP STARTING



CAUTION

To avoid personal injury:

- Battery gases can explode. Keep cigarettes, sparks, and flames away from battery.
- If tractor battery is frozen, do not jump start engine.
- Do not connect other end of negative ⊖ jumper cable to negative ⊕ terminal of tractor battery.

When jump starting engine, follow the instructions below to safely start the engine.

- (1) Bring helper vehicle with a battery of the same voltage as disabled tractor within easy cable reach. "THE VEHICLES MUST NOT TOUCH".
- (2) Engage the parking brakes of both vehicles and put the shift levers in neutral. Shut the engine off.
- (3) Put on safety goggles and rubber gloves.
- (4) Remove the vent caps from both batteries. (if equipped)
- (5) Cover vent holes with damp rags. Do not allow the rag to touch the battery terminals.
- (6) Attach the red clamp to the positive (red, ⊕ or pos.) terminal of the dead battery and clamp the other end of the same cable to the positive (red, ⊕ or pos.) terminal of the helper battery.
- (7) Clamp the other cable to the negative (black, ⊖ or neg.) terminal of the helper battery.
- (8) Clamp the other end to the engine block or frame of the disabled tractor as far from the dead battery as possible.
- (9) Start the helper vehicle and let its engine run for a few moments. Start the disabled tractor.
- (10) Disconnect the jumper cables in the exact reverse order of attachment. (Steps 8, 7 and 6).
- (11) Remove and discard the damp rags. Reinstall the vent caps.

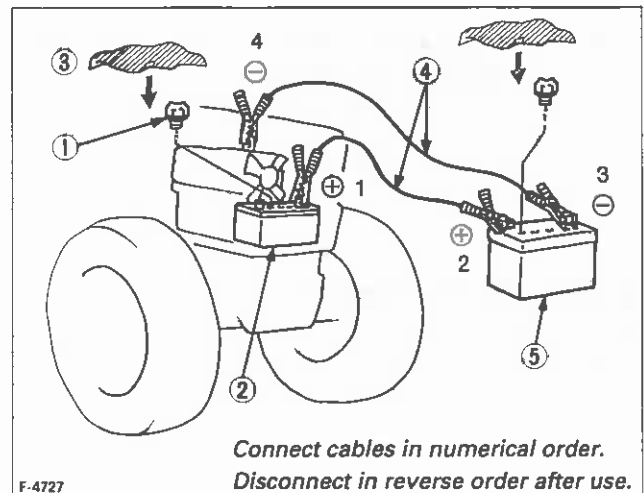

- ① Remove vent caps (if equipped)
- ② Dead battery
- ③ Lay a damp rag over open vents
- ④ Jumper cables
- ⑤ Helper battery

IMPORTANT:

- This machine has a 12volt negative ⊖ ground starting system.
- Use only same voltage for jump starting.
- Use of a higher voltage source on tractors electrical system could result in severe damage to tractors electrical system. Use only matching voltage source when "Jump starting" a low or dead battery condition.

OPERATING THE TRACTOR

OPERATING NEW TRACTOR

How a new tractor is handled and maintained determines the life of the tractor.

A new tractor just off the factory production line has been, of course, tested, but the various parts are not accustomed to each other, so care should be taken to operate the tractor for the first 50 hours at a slower speed and avoid excessive work or operation until the various parts become "broken-in." The manner in which the tractor is handled during the "breaking-in." period greatly affects the life of your tractor. Therefore, to obtain the maximum performance and the longest life of the tractor, it is very important to properly break-in your tractor. In handling a new tractor, the following precautions should be observed.

■ Do not Operate the Tractor at Full Speed for the First 50 Hours.

- Do not start quickly nor apply the brakes suddenly.
- In winter, operate the tractor after fully warming up the engine.
- Do not run the engine at speeds faster than necessary.
- On rough roads, slow down to suitable speeds. Do not operate the tractor at fast speed.

The above precautions are not limited only to new tractors, but to all tractors. But it should be especially observed in the case of new tractors.

■ Changing Lubricating Oil for New Tractors

The lubricating oil is especially important in the case of a new tractor. The various parts are not "broken-in" and are not accustomed to each other; small metal grit may develop during the operation of the tractor; and this may wear out or damage the parts. Therefore, care should be taken to change the lubricating oil a little earlier than would ordinarily be required.

For further details of change interval hours. (See "MAINTENANCE" Section)

STARTING

1. Adjusting the Operator's Position.

■ Operator's Seat



CAUTION

To avoid personal injury:

- Make sure that the seat is completely secured after each adjustment.
- Do not allow any person other than the driver to ride on the tractor.

◆ Travel adjustment

Pull up the travel adjust lever and slide the seat backward or forward, as required. The seat will lock in position when the lever is released.

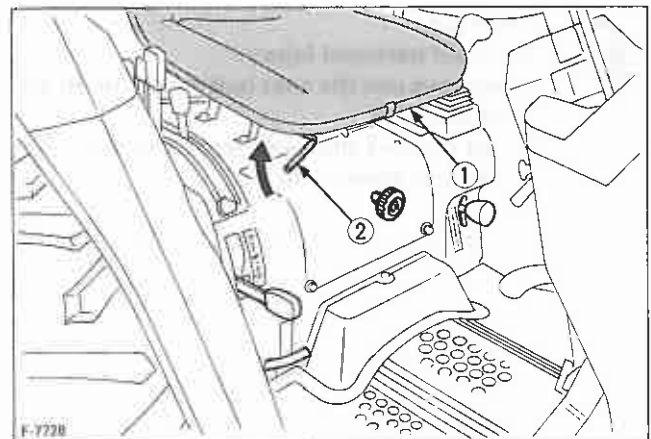

① Seat

② Adjusting lever

IMPORTANT

- After adjusting the operator's seat, be sure to check to see that the seat is properly locked.

◆ **Suspension adjustment**

Turn the knob at the back of the seat suspension to adjust seat cushioning tension.

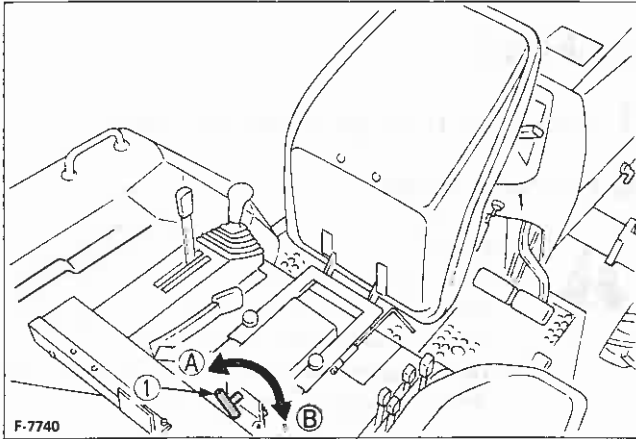

- ① Adjusting knob
- Ⓐ To decrease tension
- Ⓑ To increase tension

■ **Seat Belt**



CAUTION

To avoid personal injury:

- Always use the seat belt when the ROPS is installed.
- Do not use the seat belt if the tractor is not equipped with ROPS.

Adjust the seat for proper fit and connect to the buckle.

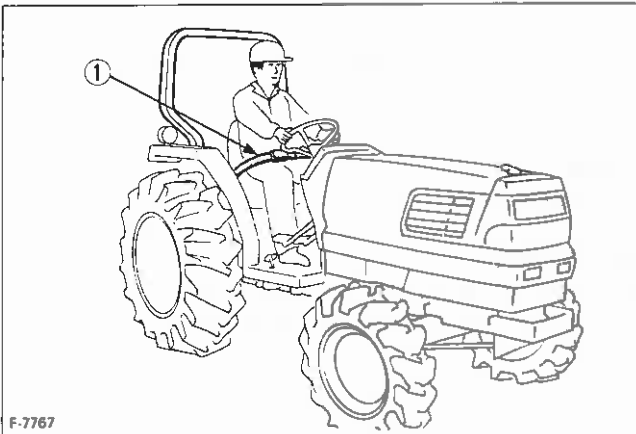

- ① Seat belt

■ **Tilt Steering Adjustment**



CAUTION

To avoid personal injury:

- Do not adjust the steering wheel while the tractor is in motion.
- Make sure the steering wheel is locked after adjusting.

Steering wheel is adjustable when tilt lever is unlocked.

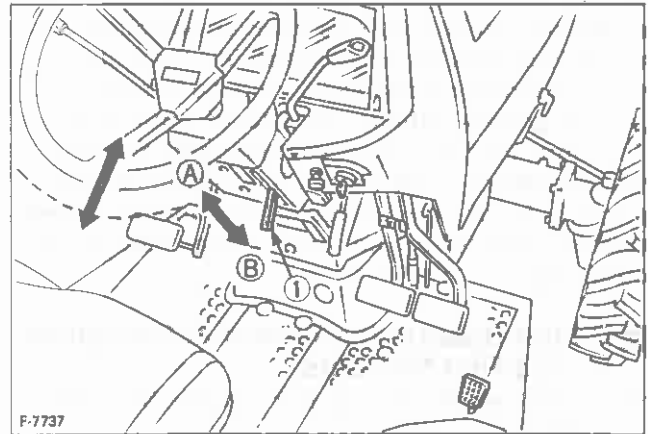

- ① Tilt lever
- Ⓐ "UNLOCK"
- Ⓑ "LOCK"

2. Selecting Light Switch Positions.

■ **Head Light Switch, Hazard Light Switch**

- Ⓐ OFF ... Head lights OFF.
- Ⓑ ... Head lights ON, high beam.
- Ⓒ ... Head lights dimmed, low beam.

When hazard light switch is turned to clockwise, the hazard lights blink. Hazard light indicators on the instrument panel monitor the hazard lights condition.

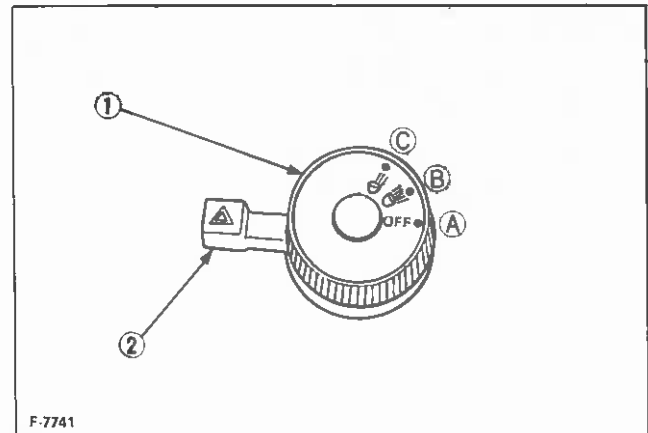

- ① Head light switch
- ② Hazard light switch

3. Checking the Brake Pedal.

■ Brake Pedals (Right and Left)



WARNING

To avoid personal injury:

- Applying only one rear wheel brake at high speeds could cause the tractor to swerve or roll-over.

- (1) Before operating the tractor on the road, be sure to interlock the right and left pedals as illustrated below.
- (2) Use individual brakes to assist in making sharp turns at slow speeds (Field Operation Only). Disengage the brake pedal lock and depress only one brake pedal.
- (3) Be sure brake pedals have equal adjustment when using locked together.

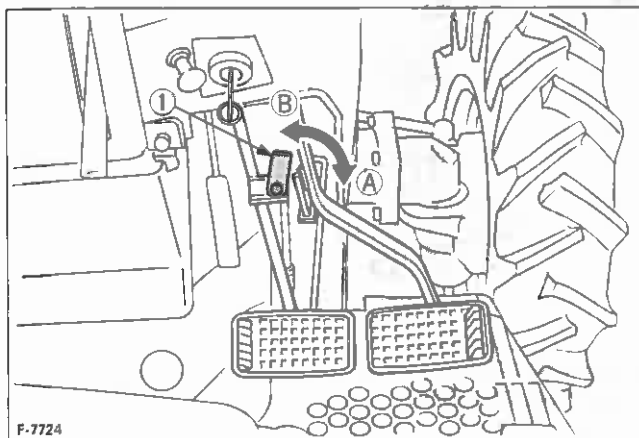

F-7724

① Brake pedal lock

Ⓐ "LOCK"

Ⓑ "RELEASE"

4. Raise the Implement. (see "HYDRAULIC UNIT" section)

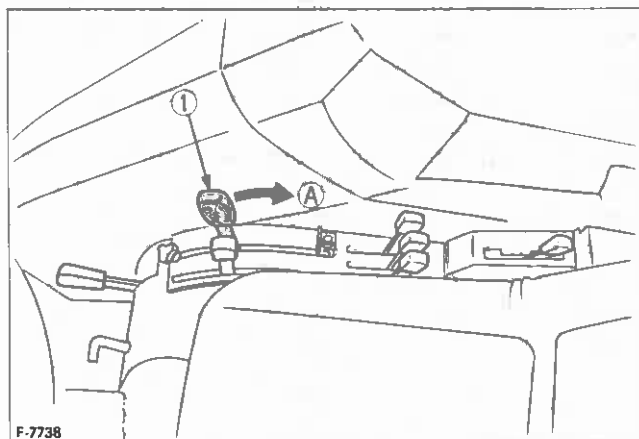

F-7738

① Position control lever

Ⓐ "UP"

5. Depress the Clutch Pedal.

■ Clutch Pedal



CAUTION

To avoid personal injury:

- Sudden release of the clutch may cause the tractor to lunge in an unexpected manner.

The clutch is disengaged when the clutch pedal is fully pressed down.

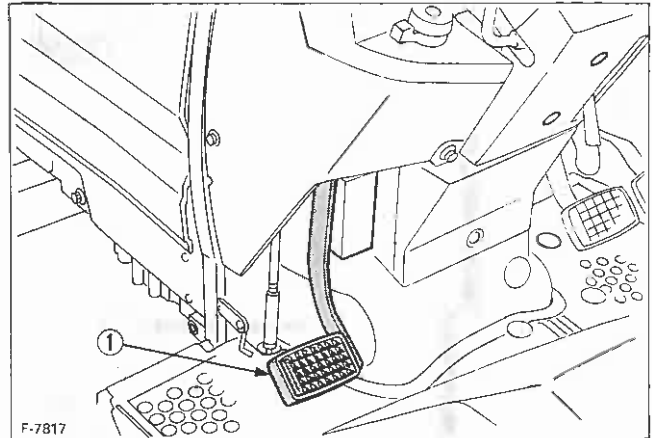

F-7817

① Clutch pedal

IMPORTANT:

To help prevent premature clutch wear:

- The clutch pedal must be quickly disengaged and be slowly engaged.
- Avoid operating the tractor with your foot resting on the clutch pedal.
- Select proper gear and engine speeds depending on the type of job.

6. Selecting the Travel Speed.

[GST Type]

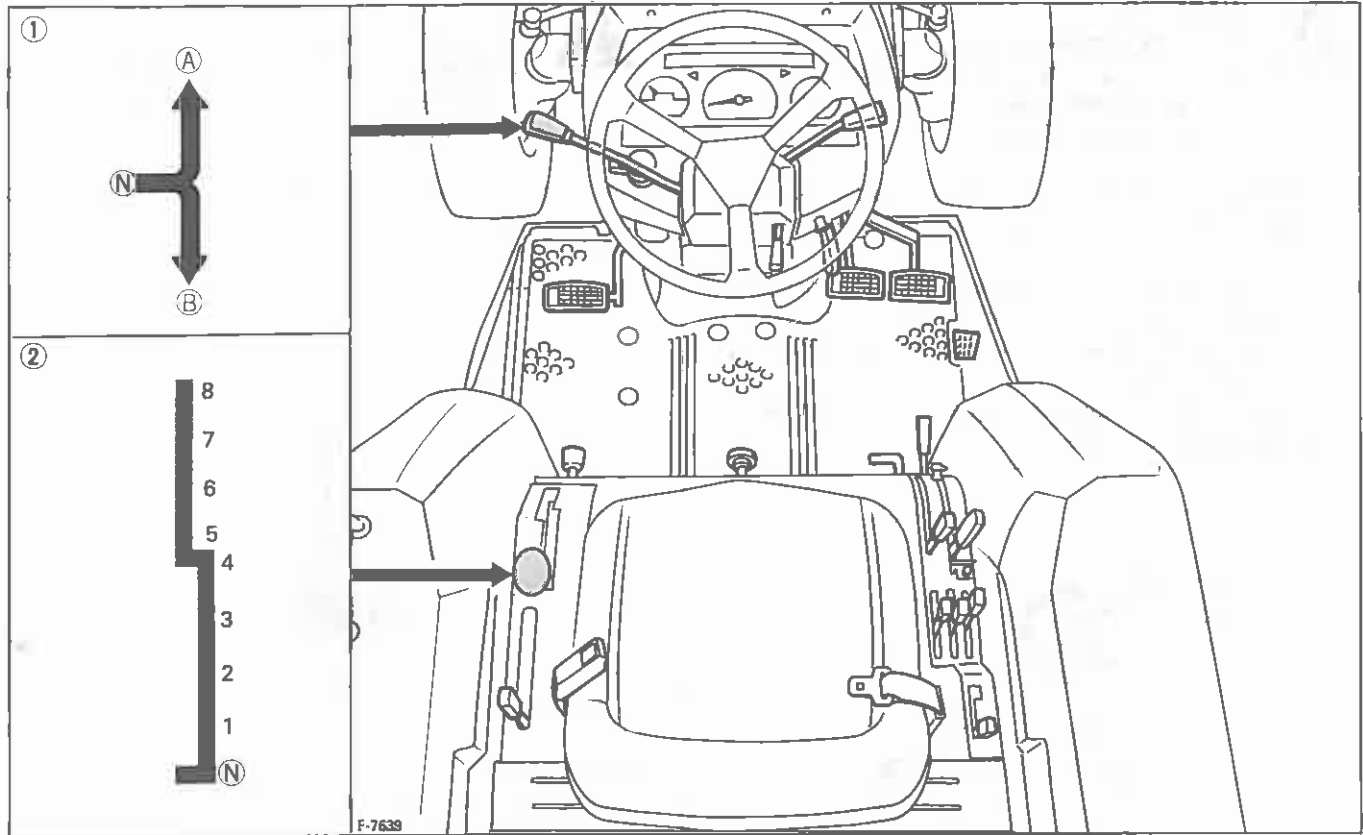

- ① Shuttle shift lever
- ② Main gear shift lever

- A "FORWARD"
- B "REVERSE"

- N "NEUTRAL POSITION"

Shuttle Shift Lever



WARNING

To avoid personal injury:

BEFORE DISMOUNTING TRACTOR:

- **ALWAYS SET PARKING BRAKE**
Leaving transmission in gear with the engine stopped will not prevent tractor with GST transmission from rolling.
- **STOP THE ENGINE AND REMOVE THE KEY**

Raise up and shift the shuttle shift lever forward to obtain forward speeds and shift it backward to obtain reverse speeds without using the clutch pedal. Tractor with glide shift transmission can obtain live PTO by moving shuttle shift lever to neutral position.

IMPORTANT:

- Reduce engine speed to low idle before shifting the shuttle shift lever.
- Shuttle shift change should not be done all at one time. Move the shuttle shift lever to the neutral position momentarily before you accomplish the shuttle change.

Main Gear Shift Lever

Main gear shift lever has NINE positions, neutral and 1st thru 8th gear. Main gear shift lever pattern is shown in the following illustration.

With the Glide Shift Transmission, you can shift at any time, stopped or on-the-go. The Shuttle Shift lever must be in forward or reverse.

There is no need to use the clutch when starting out or shifting up or down.

"Live" PTO operation can be obtained with Glide Shift Transmission tractors [Without independent PTO type]. Depress clutch and move PTO gear shift lever to 540 rpm. Release the clutch and the PTO will be engaged. Move Shuttle shift lever to forward or reverse. Forward or Reverse movement can now be obtained with the main gear shift lever. To stop the tractor movement without disengaging PTO, shift main gear shift lever to neutral or move shuttle shift lever to neutral and set parking brake.

The PTO continues running even if you change the traveling speed or stop the tractor.

Before dismounting tractor, shift the main gear shift lever to the neutral position and set parking brake.

IMPORTANT:

- Start in lower gears and shift one gear at a time until desired gear is obtained.
- To prolong clutch life, avoid slipping the hydraulic clutch. Pay attention to the following points:
- Select proper gear and engine speeds depending on the type of job.
- Avoid lugging the engine, especially in higher gears. If RPM's drop excessively, shift to a lower gear.
- In cold climate, it may take longer for the main gear shift lever to work. This is because the transmission oil must get warm enough.
 - Warm up the machine long enough. If there is not enough time to do so, start the machine with the shuttle shift lever or the clutch.
 - There is no problem with a delay in starting. The machine will start as the oil temperature goes up.

**CAUTION**

To avoid personal injury:

- Use the clutch when making an emergency stop or working in confined areas, such as getting tractor in position to attach an implement.
- An accident may occur with erratic shifting operation.
For safe operation, move main gear shift lever only one gear at a time.
- Shift the main gear shift lever firmly and without hesitation. Improper shift lever position will cause the tractor to momentarily coast on slopes.
- Before descending a hill, shift to a gear low enough to control tractor speed without using brakes.
If you change the speed descending a hill, use the brakes during that operation to keep control of the vehicle.
- Operate in reverse at slow speeds to maintain control.

[Manual Transmission Type]

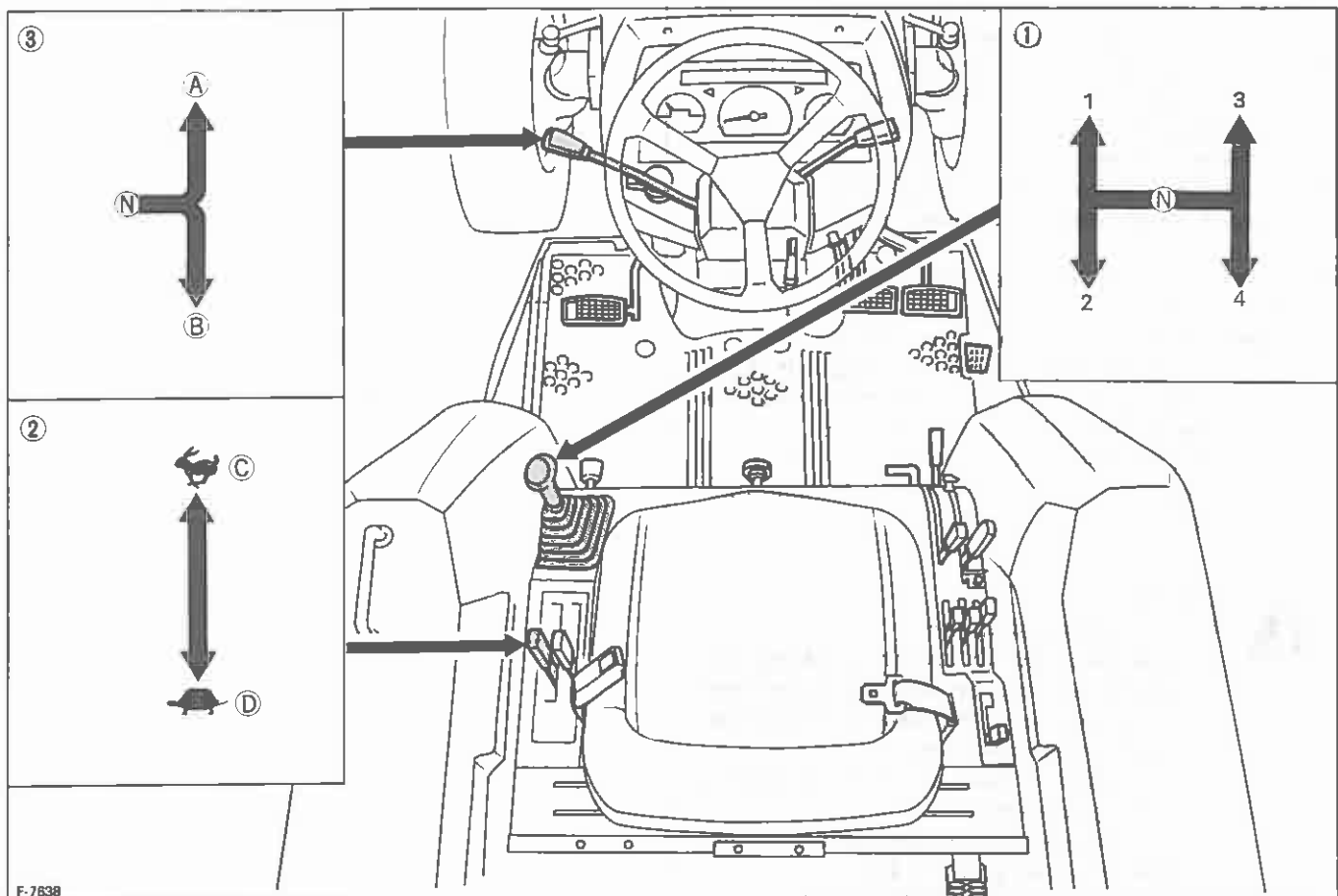

F-7638

- ① Main gear shift lever
- ② Range gear shift lever
(Auxiliary gear shift lever)
- ③ Synchro-shuttle shift lever
- A "FORWARD"
- B "REVERSE"
- C "HIGH"
- D "LOW"
- N "NEUTRAL POSITION"

■ Main Gear Shift Lever

The main gear shift is fully synchronized to shift without stopping.

IMPORTANT:

- The main gear shift may be shifted between speeds on-the-go, but clutch must be depressed.

■ Range Gear Shift Lever (Auxiliary gear shift lever)

The range gear shift can only be shifted when tractor is completely stopped and clutch is depressed.

IMPORTANT:

- To avoid transmission damage, depress clutch pedal and stop tractor before shifting between ranges.

■ Synchro-Shuttle shift Lever

Raise up and shift the shuttle shift lever forward to obtain forward speeds and shift back to obtain reverse speeds. This shifting requires clutch operation.

IMPORTANT:

- The synchro shuttle shift lever may be shifted while the tractor is moving slowly, but sudden gear shift may cause transmission damage.

Creep Gear Shift Lever (if equipped)

Shift the creep gear shift lever at "O" to obtain high speeds and shift it "A" to obtain low speeds. This shifting requires clutch operation.

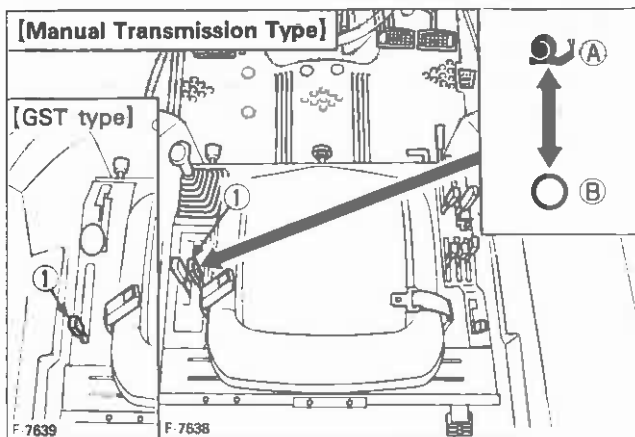

① Creep gear shift lever A "LOW"... Creep ON
 B "HIGH"... Creep OFF

◆ Creep speed (attained by shifting the creep gear shift lever to "A") should be used only when doing one of the following jobs:

- (1) Deep rotary-tilling and harrowing
- (2) Planting
- (3) Turf application

◆ Creep speed can not be used for any of the following:

- (1) Pulling a trailer
- (2) Front-loader operation
- (3) Front-blade operation
- (4) Earth-moving
- (5) Entering and leaving a field
- (6) Loading onto and unloading from a truck



CAUTION

To avoid personal injury:

- When you leave the tractor, be sure to apply the parking brake and stop the engine.
- IN APPLYING THE BRAKES:
 - The torque of the wheel axle is extremely high while creep speed is being used. Be sure to step down on the clutch pedal completely before applying the brakes, or they will not work.
 - When starting to operate the tractor, be sure to release the parking brakes. Misuse of the brakes may cause damage to the transmission and is therefore not acceptable to KUBOTA for coverage under the warranty.

IMPORTANT:

- Press the clutch pedal completely down and stop the tractor's motion before shifting the creep gear shift lever.

Front Wheel Drive Lever



CAUTION

To avoid personal injury:

- Do not engage the front wheel drive when traveling at road speed, or the tractor may stop quickly more than expected when applying the brake. An accident may occur if the tractor is suddenly braked.

Use the lever to engage the front wheels with the tractor stopped. Shift the lever to "ON" to engage the front wheel drive.

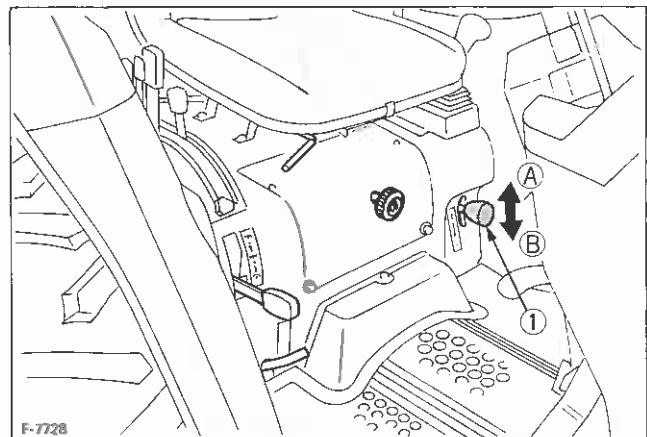

① Front wheel drive lever A "ON"
 B "OFF"

IMPORTANT:

- Depress the clutch pedal before engaging the front wheel drive lever.
- Tires will wear quickly if front wheel drive is engaged on paved roads.

◆ Front wheel drive is effective for the following jobs:

- (1) When greater pulling force is needed, such as working in a wet field, when pulling a trailer, or when working with a front-end loader.
- (2) When working in sandy soil.
- (3) When working on a hard soil where a rotary tiller might push the tractor forward.

7. Accelerate the Engine.

■ Hand Throttle Lever

Pulling the throttle lever back increases engine speed, and pushing it forward decreases engine speed.

■ Foot Throttle

Use the foot throttle when travelling on the road. Press down on it for higher speed. The foot throttle is interlocked with the hand throttle lever; when using the foot throttle, keep the hand throttle lever in low idling position.

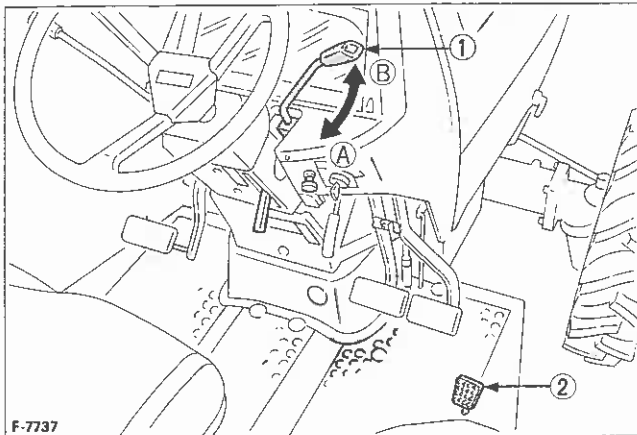

- ① Hand Throttle lever A "INCREASE"
- ② Foot Throttle B "DECREASE"

8. Unlock the Parking Brake and Slowly Release the Clutch.

■ Parking Brake Lever

To release the parking brake, depress the brake pedals again. When the parking brake is released, parking brake indicator in the Easy Checker™ goes off.

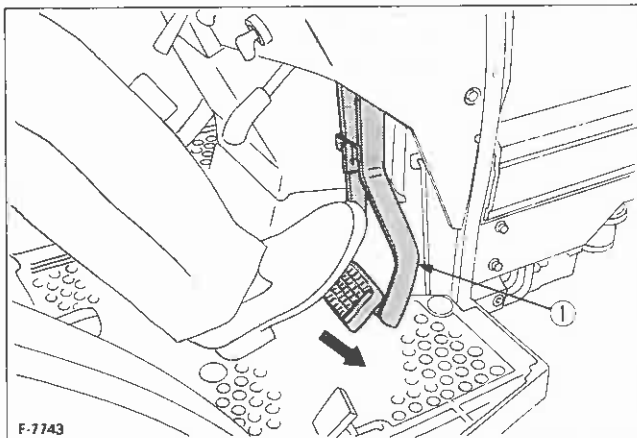

- ① Brake pedals

STOPPING

■ Stopping

- (1) Slow the engine down.
- (2) Step on the clutch and brake pedal.
- (3) After the tractor has stopped, disengage the PTO, lower the implement, shift the transmission to neutral, release the clutch pedal, set the parking brake.

CHECK DURING DRIVING

■ Immediately Stop the Engine if:

- The engine suddenly slows down or accelerates,
- Unusual noises suddenly appear,
- Exhaust fumes suddenly become very dark,

While driving, make the following checks to see that all the parts are functioning normally.

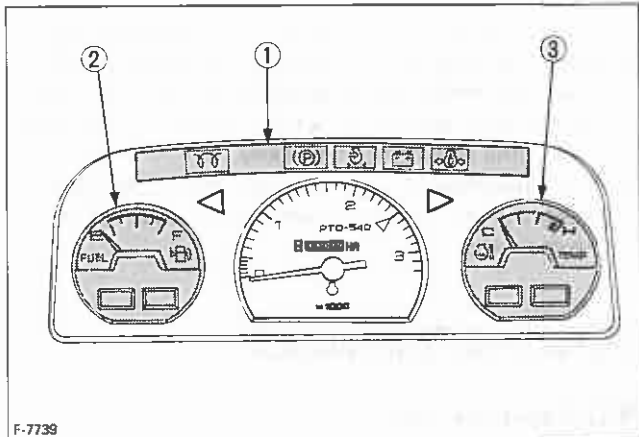

F-7739

- ① Easy checker™
- ② Fuel gauge
- ③ Coolant temperature gauge

■ Easy Checker™

If the warning lamps in the Easy Checker™ come on during operation, immediately stop the engine, and find the cause as shown below.

Never operate the tractor while Easy Checker™ lamp is on.

⊖ Engine oil pressure.

If the oil pressure in the engine goes below the prescribed level, the warning lamp in the Easy Checker™ will come on.

If this should happen during operation, and it does not go off when the engine is accelerated to more than 1000 rpm, check level of engine oil.

(See "Checking Engine Oil Level" in daily check in periodic service section.)

⊖ Air cleaner.

If the air cleaner is clogged, the warning lamp in the Easy Checker™ will come on.

If this should happen during operation, clean the air cleaner element.

(See "Cleaning Air Cleaner Element" in every 100 hours in periodic service section.)

⊖ Electrical charge

If the alternator is not charging the battery, the warning lamp in the Easy Checker™ will come on.

If this should happen during operation, check the electrical charging system or consult your local KUBOTA dealer.

NOTE:

- For checking and servicing of your tractor, consult your local KUBOTA dealer for instructions.

■ Fuel Gauge

When the key switch is on, the fuel gauge indicates the fuel level.

Be careful not to empty the fuel tank. Otherwise air may enter the fuel system.

Should this happen, the system should be bled (See "Bleeding Fuel System" in as required in Periodic Service Section)

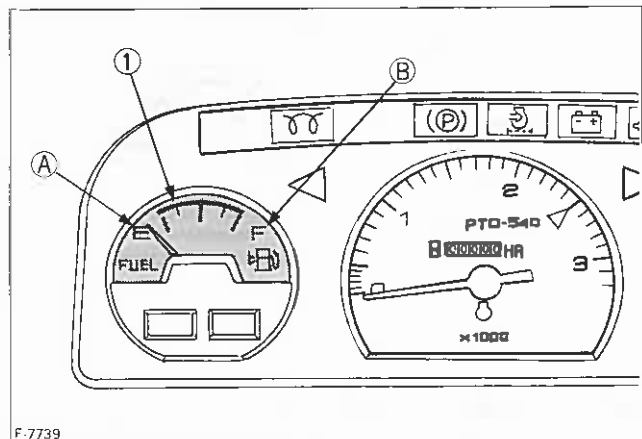

F-7739

- ① Fuel gauge
- Ⓐ "EMPTY"
- Ⓑ "FULL"

Coolant Temperature Gauge



CAUTION

To avoid personal injury:

- Do not remove radiator cap until coolant temperature is well below its boiling point. Then loosen cap slightly to the stop to relieve any pressure before removing cap completely.

- With the key switch at "ON", this gauge indicates the temperature of the coolant. "C" for "cold" and "H" for "hot."
- If the indicator reaches the "H" setting (red zone), engine coolant is overheated. Check the tractor by referring to "Troubleshooting" section.

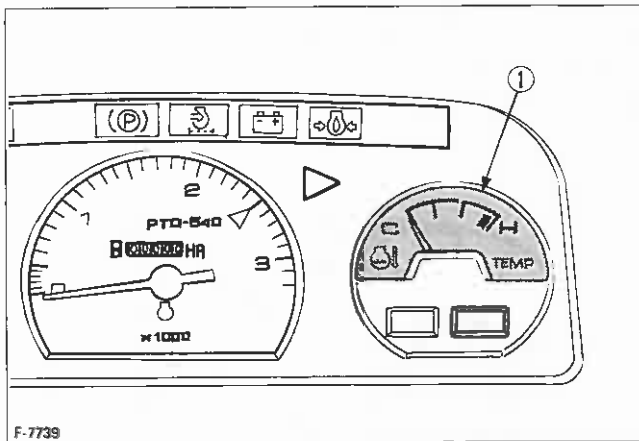

F-7739

① Coolant temperature gauge

Hourmeter/Tachometer

This meter gives readings for engine speed, PTO shaft speed and the hours the tractor has been operated.

- The tachometer shows the engine speed and corresponding PTO shaft speed.
- The hourmeter indicates in five digits the hours the tractor has been used; the last digit indicates 1/10 of an hour.

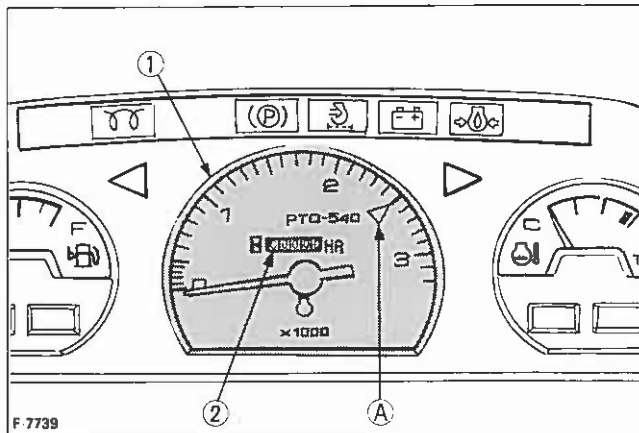

F-7739

① Engine revolution A PTO: 540rpm
② Hours used

PARKING

Parking



CAUTION

To avoid personal injury:

- Always set the parking brake and stop the engine before leaving the tractor seat.

- When parking, be sure to set the parking brake.
- Before getting off the tractor, disengage the PTO, lower all implements, place all control levers in their neutral positions, set the parking brake, stop the engine and remove the key.
- If it is necessary to park on an incline, be sure to chock the wheels to prevent accidental rolling of the machine.

OPERATING TECHNIQUES

Differential Lock



WARNING

To avoid personal injury:

- It is extremely dangerous to operate tractor at high speed or attempt to turn the tractor in either direction with differential lock engaged. Be sure to release the lock before making such a turn.

If one of the rear wheels should slip, step on the differential lock pedal. Both wheels will then turn together, reducing slippage.

Differential lock is maintained only while the pedal is depressed.

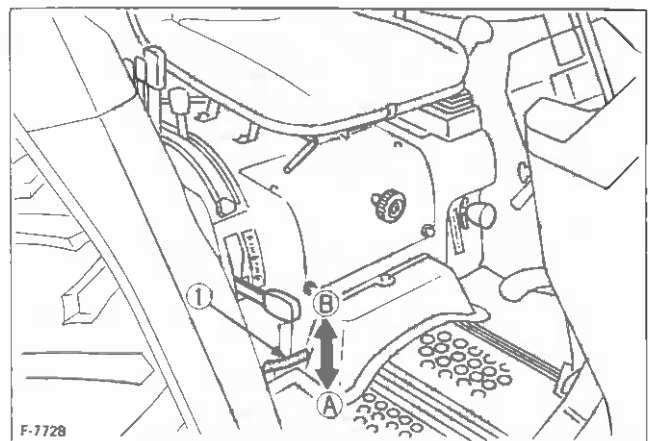

F-7728

① Differential lock pedal A Press to "ENGAGE"
B Release to "DISENGAGE"

IMPORTANT:

- To prevent damage to power train, do not engage differential lock when one wheel is spinning and the other is completely stopped.
- When using the differential lock, always slow the engine down.
- If the differential lock cannot be released in the above manner, step lightly on the brake pedals alternately.

■ Operating the Tractor on a Road



CAUTION

To avoid personal injury:

- To help assure straight line stops when driving at transport speeds, lock the brake pedals together. Uneven braking at road speeds could cause the tractor to roll-over.
- When traveling on road with 3-point hitch mounted implement attached, be sure to have sufficient front weight on the tractor to maintain steering ability.

Be sure SMV emblem and warning lamps are clean and visible. If towed or rear-mounted equipment obstructs these safety devices, install SMV emblem and warning lamps on equipment.

Consult your local KUBOTA dealer for further detail.

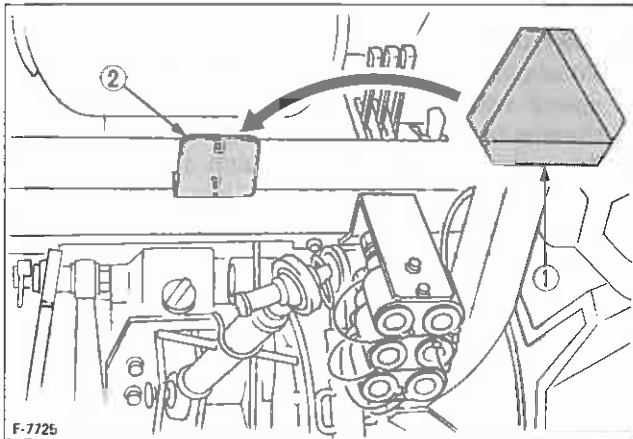

① SMV emblem

② Bracket

■ Operating on Slopes and Rough Terrain.



CAUTION

To avoid personal injury:

- Always back up when going up a steep slope. Driving forward could cause the tractor to tip over backward. Stay off hills and slopes too steep for safe operation.
- If descending a slope, never disengage the clutch or shift levers to neutral. Doing so could cause the tractor to speed up out of control.
- Do not drive the tractor close to the edges of ditches or banks which may collapse under the weight of the tractor. Especially when the ground is loose or wet.

- (1) Be sure wheel tread is adjusted to provide maximum stability.
(See "Wheel Adjustment" in wheels, Tires and Ballast section.)
- (2) Slow down for slopes, rough ground, and sharp turns, especially when transporting heavy, rear mounted equipment.
- (3) Before descending a slope, shift to a gear low enough to control speed without using brakes.

■ Directions for Use of Power Steering

- (1) Power steering is activated only while the engine is running. Slow engine speeds make the steering a little heavier. While the engine is stopped, the tractor functions in the same manner as tractors without power steering.
- (2) When the steering wheel is turned all the way to the stop, the relief valve is activated. Do not hold the steering wheel in this position for a long period of time.
- (3) Avoid turning the steering wheel while the tractor is stopped, or tires and rims may wear out sooner.
- (4) The power steering mechanism makes the steering easier. Be careful when driving on a road at high speeds.

PTO

PTO OPERATION



CAUTION

To avoid personal injury:

- Disengage PTO, stop engine, and allow all rotating components to come to a complete stop before connecting, disconnecting, adjusting, or cleaning any PTO driven equipment.

■ PTO Gear Shift Lever [Without independent PTO type]

- (1) The tractor has a 540 rpm speed position.
- (2) PTO shifting needs clutch operation. Press the clutch pedal down completely to stop the tractor movement and any PTO driven equipment movement before shifting the PTO gear shift lever.

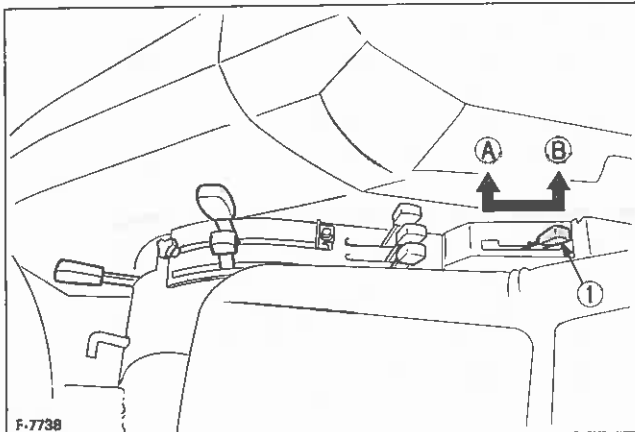

① PTO gear shift lever

Ⓐ "ON"
Ⓑ "OFF"

IMPORTANT:

- To avoid shock loads to the PTO, reduce engine speed when engaging the PTO, then open the throttle to the recommended speed:
- To avoid damage of transmission, before shifting the PTO gear shift lever, fully disengage the main clutch.

Model	Engine Speed rpm	Shaft	PTO Speed rpm
L2900 · L3300	2670	6-Spline	540
L3600 · L4200	2447		

NOTE:

- There is a PTO-1 (540rpm) indicated mark on the tachometer board.
- Tractor engine will not start if PTO gear shift lever is in the engaged "ON" position.

■ PTO Clutch Control Lever [With independent PTO type]

- (1) The tractor has a 540 rpm speed position.
- (2) The PTO clutch control lever engages or disengages the PTO clutch which gives the PTO independent control.

Shift the lever to "ON" to engage the PTO clutch. Shift the lever to "OFF" to disengage the PTO clutch.

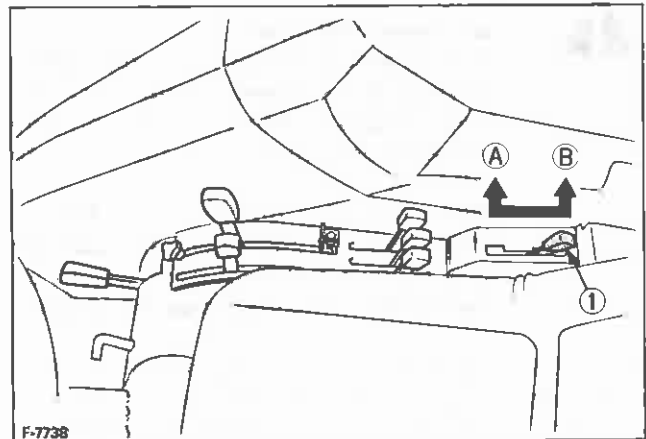

① PTO clutch control lever

Ⓐ "ON"
Ⓑ "OFF"

IMPORTANT:

- To avoid shock loads to the PTO, reduce engine speed when engaging the PTO, then open the throttle to the recommended speed:
- To avoid damage of PTO clutch and implement, shift the PTO clutch control lever slowly, when engaging the PTO clutch. Do not keep the PTO clutch control lever half way.

Model	Engine Speed rpm	Shaft	PTO Speed rpm
L2900 · L3300	2700	6-Spline	540
L3600 · L4200	2475		

NOTE:

- There is a PTO-1 (540rpm) indicated mark on the tachometer board.
- Tractor engine will not start if PTO clutch control lever is in the engaged "ON" position.

Mid-PTO (if equipped)



WARNING

To avoid personal injury:

- Before operation, be sure to select the correct PTO lever (mid/rear).
- Do not operate rear-PTO driven implements and mid-PTO driven implements at the same time.

[Without independent PTO type]

To use mid-PTO, shift the PTO gear shift lever and mid-PTO lever to engaged position. This shifting requires clutch pedal operation.

[With independent PTO type]

To use mid-PTO, shift the mid-PTO lever to engaged position and shift the PTO clutch control lever to engaged position.

Mid-PTO lever

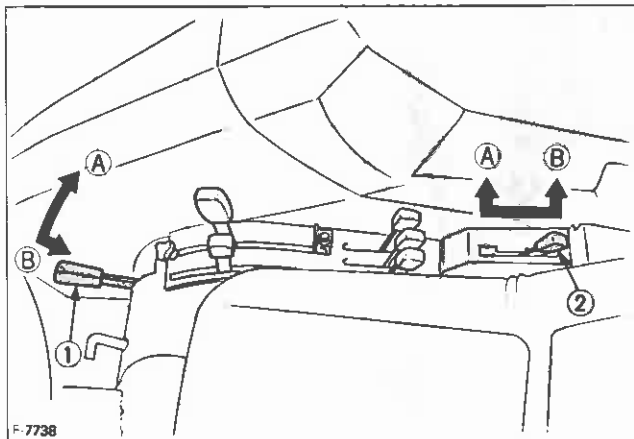

- ① Mid-PTO lever
 - ② PTO gear shift lever
 - A "ENGAGE"
 - B "DISENGAGE"
- [Without independent PTO type]/*
PTO clutch control lever
[With independent PTO type]

Rear and Mid-PTO speed

PTO REVOLUTION (rpm)			
MID-PTO LEVER	PTO	PTO Gear shift lever/ PTO Clutch control lever	
	REAR	0	540
	MID	0	0
	REAR	0	540
	MID	0	2000

Mid-PTO

The mid-PTO is available for KUBOTA approved implements.

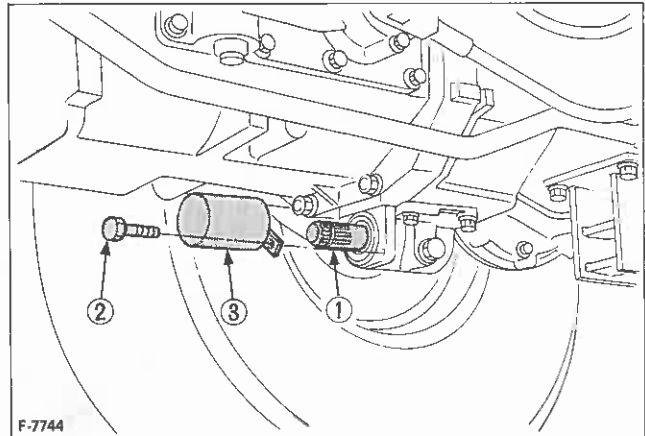

- ① Mid-PTO
- ② Bolt
- ③ PTO shaft cover

PTO Shaft Cover and Shaft Cap

Keep the PTO shaft cover in place at all times. Replacing the PTO shaft cap when the shaft is not in use. When connecting or disconnecting the joint to PTO shaft, raise up the PTO shaft cover.

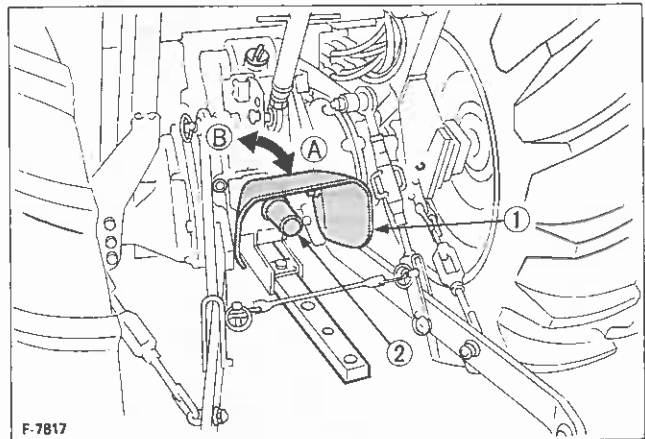

- ① PTO shaft cover
- ② PTO shaft cap
- A "NORMAL POSITION"
- B "RAISED POSITION"

THREE-POINT HITCH & DRAWBAR

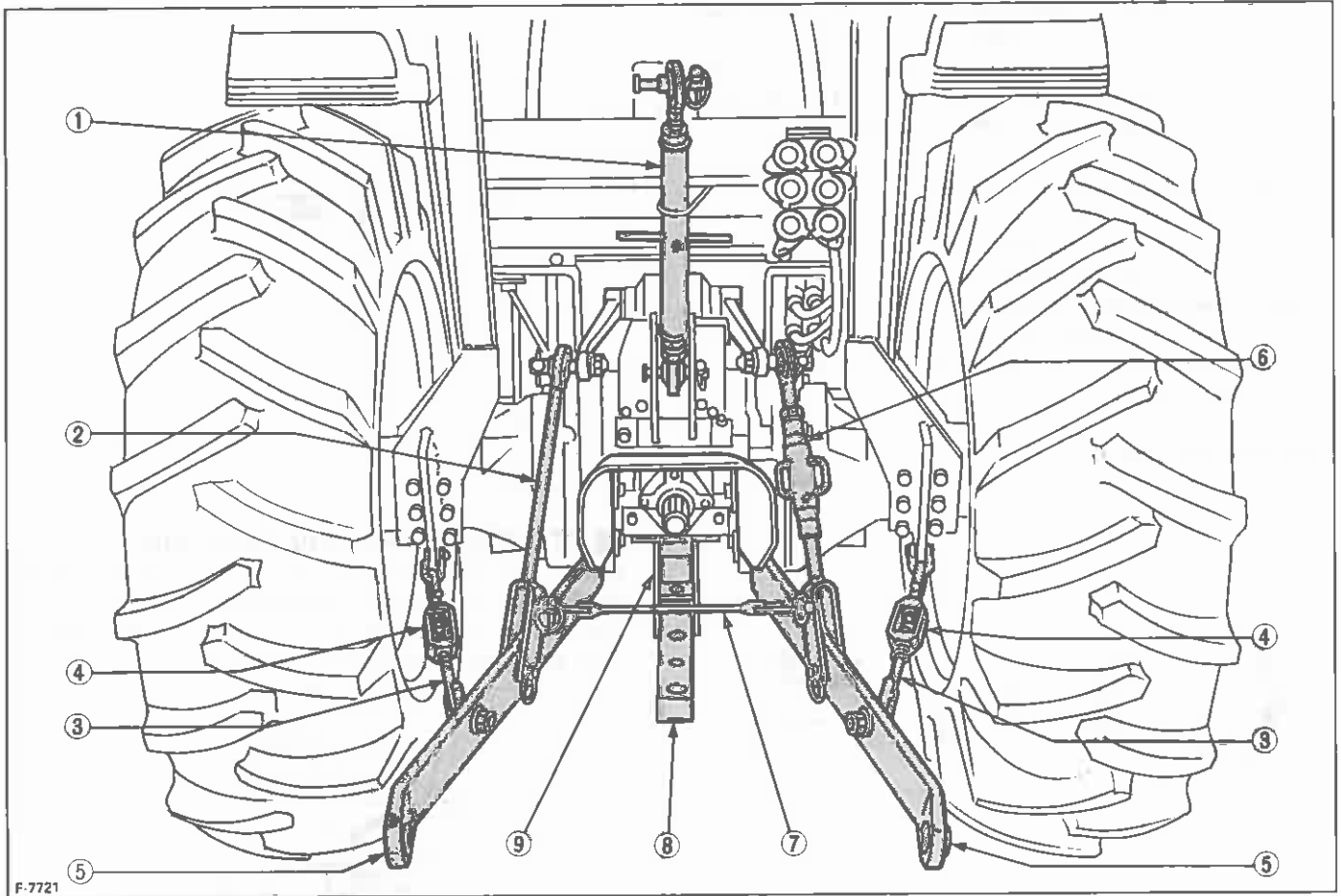

F-7721

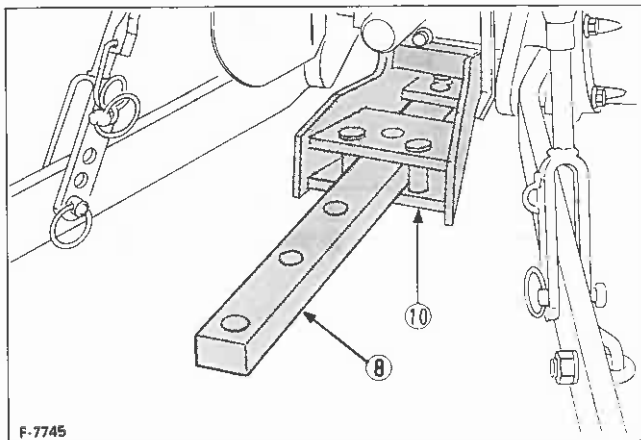

F-7745

- ① Top link
- ② Lifting rod (Left)
- ③ Check chains
- ④ Turnbuckle
- ⑤ Lower link
- ⑥ Lifting rod (Right)
- ⑦ Lower link holder
- ⑧ Drawbar
- ⑨ Fixed drawbar frame
[for USA]
- ⑩ Swing drawbar frame
[for CANADA]
[option for USA]

3-POINT HITCH

1. Make preparations for attaching implement

■ Selecting the Top Link Mounting Holes

Select the proper set of holes by referring to the "Hydraulic Control Reference Chart" in Hydraulic Unit section.

If the hydraulic unit is set for draft control, draft response is more sensitive when an implement is connected to the upper set of top link mounting holes. If draft control is not required, it is recommended to use the low set ④.

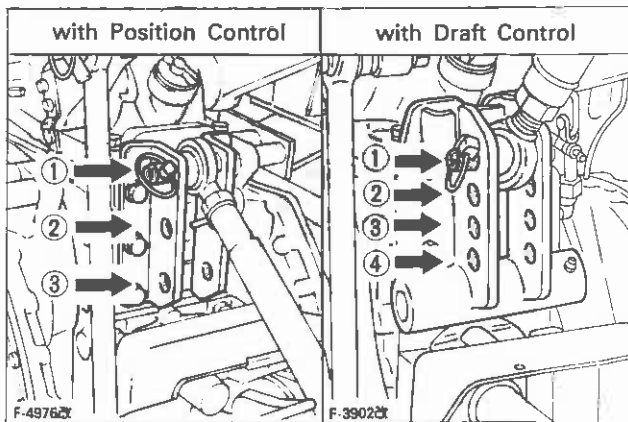

■ Drawbar

Remove the drawbar if close mounted implement is being attached.

2. Attaching and detaching implements



CAUTION

To avoid personal injury:

- Be sure to stop the engine.
- Do not stand between tractor and implement unless parking brake is applied.
- Before attaching or detaching implement locate the tractor and implement on a firm level surface.
- Whenever an implement or other attachment is connected to the tractor 3-point hitch, check full range of operation for interference, binding or PTO separation.

■ Lifting Rod (Right)

Level a 3-point mounted implement from side to side by turning the adjusting handle to shorten or lengthen the adjustable lifting rod.

After adjustment, tighten the lock nut securely.

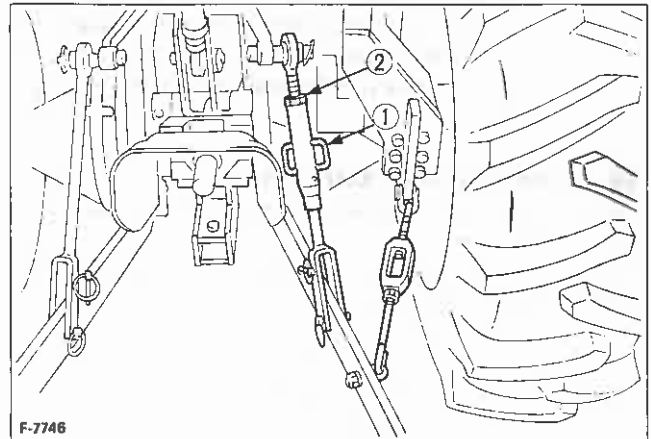

① Adjusting handle

② Lock nut

■ Top Link

(1) Adjust the angle of the implement to the desired position by shortening or lengthening the top link.

(2) The proper length of the top-link varies according to the type of implement being used.

■ Check Chains

Adjust the turn buckle to control horizontal sway of the implement.

After adjustment, retighten the lock nut.

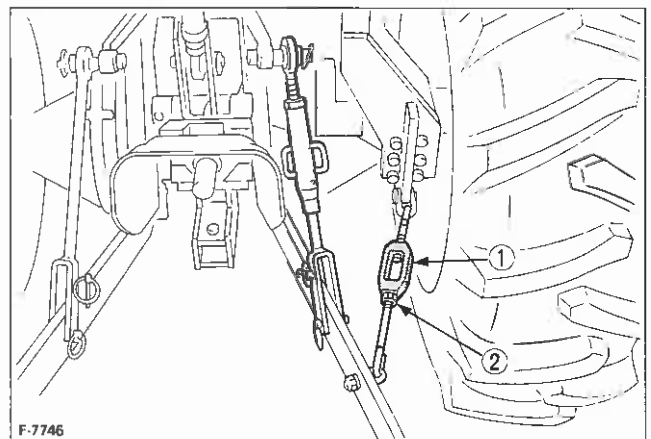

① Turnbuckle

② Lock nut

■ Lower Link Holder

When operating the tractor without a 3-point hitch implement, it is necessary to lock the lower links to prevent them from hitting the tractor rear wheels.

DRAWBAR



CAUTION

To avoid personal injury:

- Never pull from the top link, the rear axle or any point above the drawbar. Doing so could cause the tractor to tip over rearward causing personal injury.

■ Adjusting Drawbar Length

When towing an implement, recommend use of (B) hole in drawbar.

The drawbar load is referred to "IMPLEMENT LIMITATIONS" section.

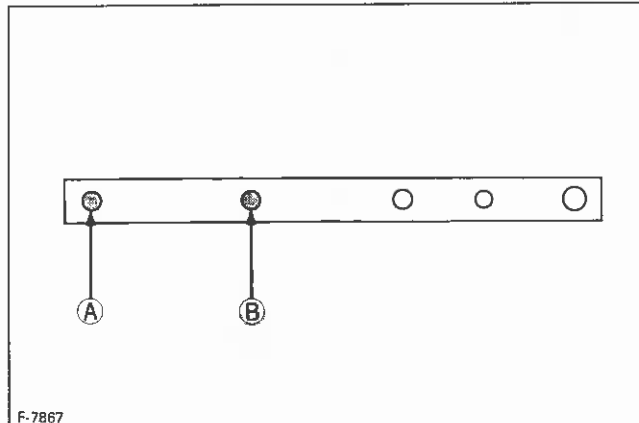
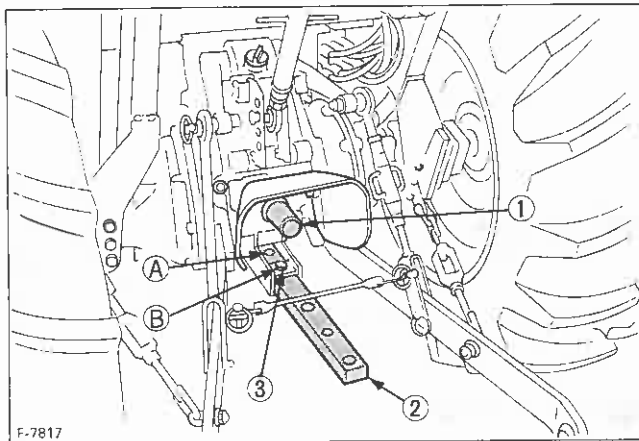

- ① PTO shaft
- ② Drawbar
- ③ Drawbar pin

Holes : (A), (B)

■ Swing Drawbar

The drawbar can be used in three different ways as illustrated below. Assemble it correctly with joint pins set at the points as marked by ● in the figure.

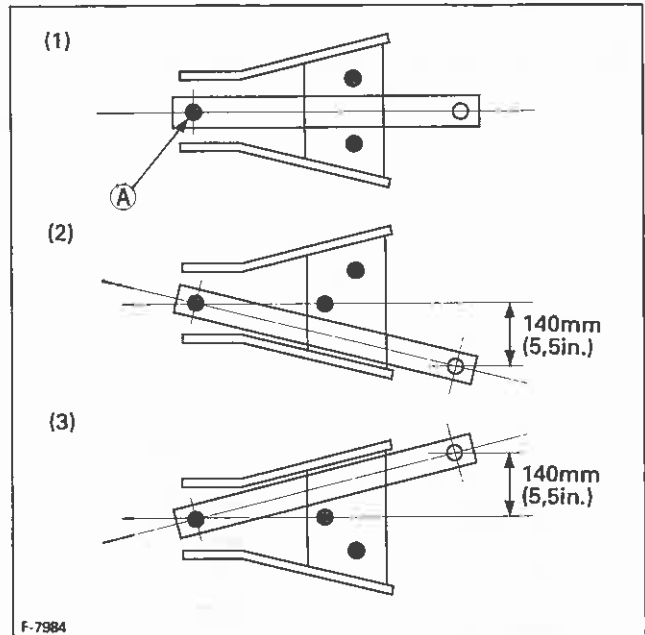

Hole : (A)

HYDRAULIC UNIT

The standard tractor has 5 hydraulic control systems as shown below. Therefore, use the most appropriate system for the implement you are using.

◆ **3-Point Hitch Control System**

1. Position Control
2. Draft Control
3. Mixed Control
4. Float Control

◆ **Remote Hydraulic Control System**

5. Combined Flow Control

IMPORTANT

- Do not operate until the engine is warmed up. If operation is attempted when the engine is still cold, the hydraulic system may be damaged.
- If noises are heard when implement is lifting after the hydraulic control lever has been activated, the hydraulic mechanism is not adjusted properly. Unless corrected the unit will be damaged. Contact your KUBOTA dealer for adjustment.

3-POINT HITCH CONTROL SYSTEM

■ **Position Control**

This will control the working depth of 3-point hitch mounted implement regardless of the amount of pull required.

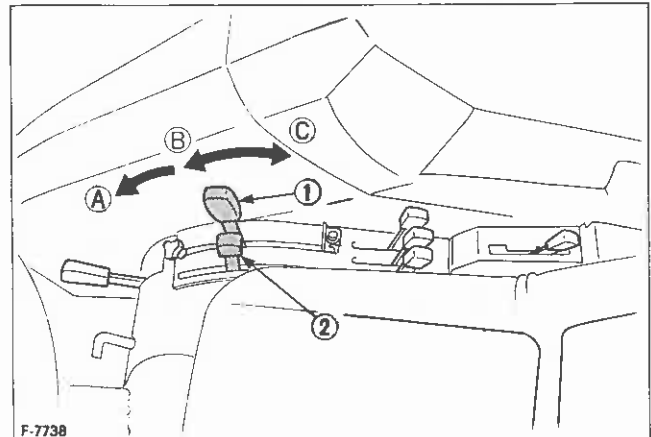

- | | |
|--------------------------|-----------|
| ① Position control lever | ▲ "FLOAT" |
| ② Draft control lever | ▲ "DOWN" |
| | ▲ "UP" |

■ **Draft Control (if equipped)**

This will control the pull of the 3-point implement. As the load on the 3-point hitch changes due to various soil conditions, the draft control system automatically responds to these changes by either raising or lowering the implements slightly to maintain a constant pull.

Place the draft control lever to the suitable position and set the implement pull with the position control lever.

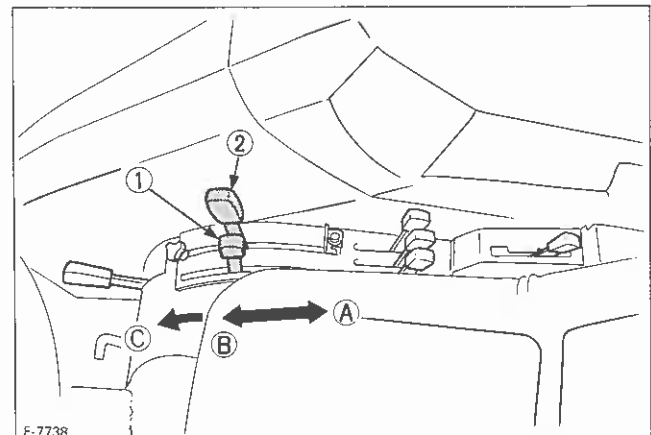

- | | |
|--------------------------|-----------------|
| ① Draft control lever | ▲ "SENSITIVE" |
| ② Position control lever | ▲ "INSENSITIVE" |
| | ▲ "FLOAT" |

■ Mixed Control

In draft control, when draft decreases, the implement automatically lowers to increase draft. However, the implement sometimes lowers too much. To limit the degree, the implement can be lowered, set the position control lever at the lowest working depth desired for the implement. Lower the draft control lever to the point where the implement is at the desired depth.

This stops the implement from going to deep and causing loose of traction and ground speed.

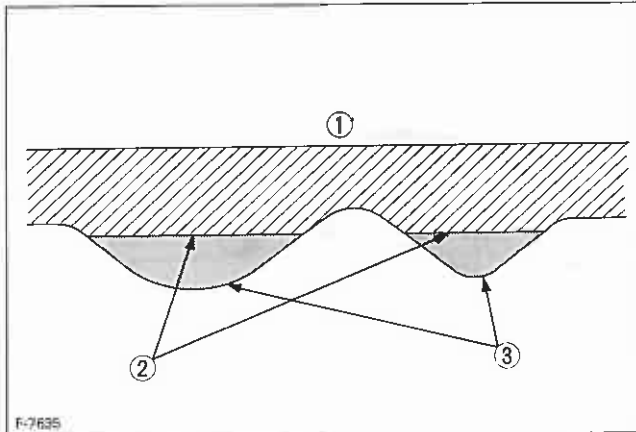

- ① Ground surface
- ② Implement penetrate limit
- ③ Light soil

■ Float Control

Place both the draft control lever and the position control lever in the float position to make the lower links move freely along with the ground conditions.

■ 3-point Hitch Lowering Speed



CAUTION

To avoid personal injury:

- Fast lowering speed may cause damage or injury. Lowering speed of implement should be adjusted to two or more seconds.

The lowering speed of the 3-point hitch can be controlled by adjusting the 3-point lowering speed knob.

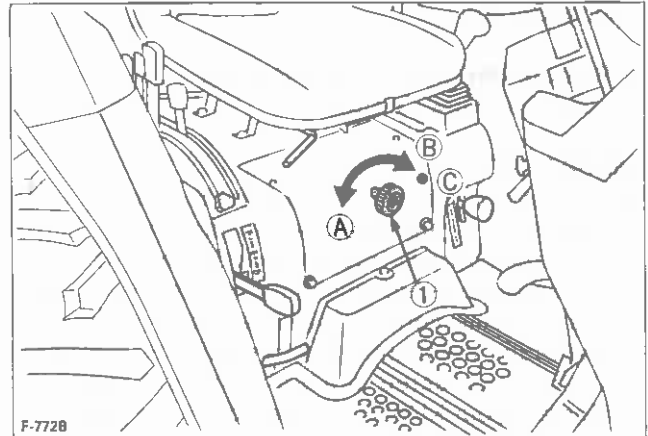

- ① 3-Point lowering speed knob
- A "FAST"
- B "SLOW"
- C "LOCK"

Hydraulic Block Type Outlet

Hydraulic block type outlet is useful when adding hydraulic operated equipment such as: front end loader, front blade, etc.

When implement is attached

- (1) Remove the plugs.
- (2) Route the implement inlet, outlet, and return hoses as shown in the illustration.
- (3) Move the control screw groove to "Vertical position" when implement is attached.

IMPORTANT:

- When an implement is not attached be sure the control screw is turned back against "Horizontal position".

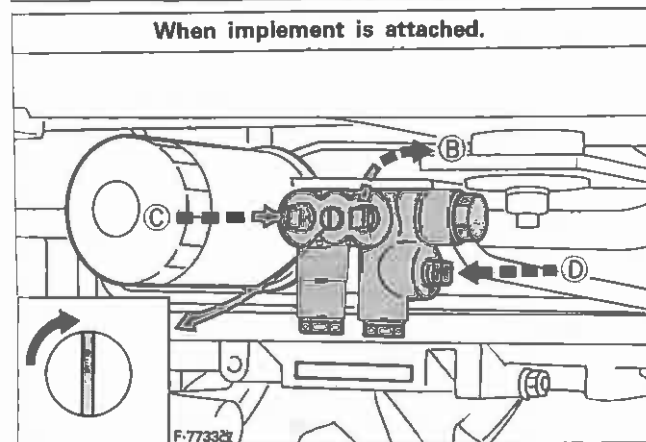
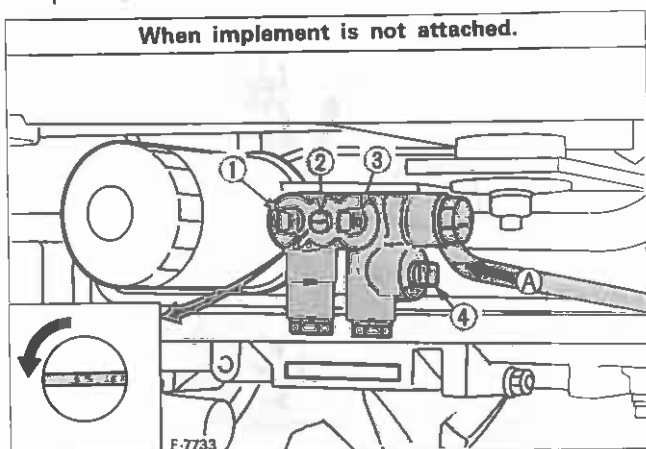

- ① Inlet (plug)
- ② Control screw
- ③ Outlet (plug)
- ④ Tank port (plug)

- Ⓐ From gear pump
- Ⓑ To implement

Max flow
 28 ℓ/min (7.4 U.S.gals/min)
 [L2900-L3300]
 31 ℓ/min (8.2 U.S.gals/min)
 [L3600-L4200]

Max pressure
 17.2 MPa (175 kgf/cm², 2490psi)

- Ⓒ From implement (Outlet)
- Ⓓ From implement (Tank port)

REMOTE HYDRAULIC CONTROL SYSTEM (if equipped)

Remote Control Valve Coupler Connecting and Disconnecting



CAUTION

To avoid personal injury:

- Stop the engine and relieve pressure before connecting or disconnecting lines.
- Do not use your hand to check for leaks.

◆ **Connecting**

- (1) Clean both couplers.
- (2) Remove dust plugs.
- (3) Insert the implement coupler to the tractor hydraulic coupler.
- (4) Pull the implement coupler slightly to make sure couplers are firmly connected.

◆ **Disconnecting**

- (1) Lower an implement first to the ground to release hydraulic pressure in the hoses.
- (2) Clean the couplers.
- (3) Relieve pressure by moving hydraulic control levers with engine shut off. Pull the hose straight from the hydraulic coupler to release it.
- (4) Clean oil and dust from the coupler, then replace the dust plugs.

NOTE:

- Your local KUBOTA dealer can supply parts to adapt couplers to hydraulic hoses.

Remote Control Valve Lever

Move the lever up or down and hold. This will raise or lower the implement. Lever will return to neutral when released.

IMPORTANT:

- Do not hold the lever in the "pull" or "push" position once the remote cylinder has reached the end of the stroke as this will cause oil to flow through the relief valve. Forcing oil through the relief valve for extended periods will overheat the oil.
- When using the tractor hydraulic system to power front loader, do not operate boom and bucket cylinders simultaneously.

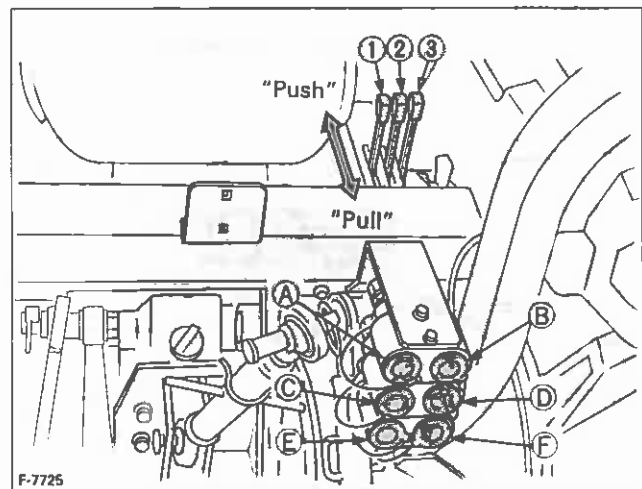

①②③ Remote control valve lever

		Pressure →		Returning ←	
Lever ①		Push		Pull	
Port	Ⓐ	In ←	Out →		
	Ⓑ	Out →	In ←		
Lever ②		Push		Pull	
Port	Ⓒ	In ←	Out →		
	Ⓓ	Out →	In ←		
Lever ③		Push		Pull	
Port	Ⓔ	In ←	Out →		
	Ⓕ	Out →	In ←		

		Coupler size
Port Ⓐ Ⓑ		PT 1/2
Port Ⓒ Ⓓ		
Port Ⓔ Ⓕ		

Hydraulic Control Unit Use Reference Chart

In order to handle the hydraulics properly, the operator must be familiar with the following. Though this information may not be applicable to all types of implements and soil conditions, it is useful for general conditions.

Implement	with Position control		with Draft control		Gauge wheel F-2016	Check chains F-7748	Remarks
	Top link mounting holes F-49752X ① ② ③	① Position control lever F-7738X	Top link mounting holes F-39022X ① ② ③ ④	① Position control lever F-7738 ② Draft control lever			
Soil condition							
Moldboard plow	Light soil Medium soil Heavy soil	1 or 2 2 or 3 3	1 or 2 2 or 3 3	Draft and Mixed control Place the draft control lever to the suitable position and set the implement pull with the position control lever	YES/NO	Loose	Adjust the check chains so that the implement can move 5 to 6 cm (2.0 to 2.4 in.) laterally. Check chains should be tight enough to prevent excessive implement movement when implement is in raised position.
Disc plow	—	2 or 3	2 or 3	Position control	YES		
Harrower (spike, springtooth, disc type)	—	2 or 3	2 or 3	Position control	YES/NO		
Sub-soiler							
Weeder, ridger							
Earthmover, digger, scraper, manure fork, rear carrier	—	3	4	Position control Hold the draft control lever at the front most position during operation.	YES/NO	Tighten	With implements with gauge wheels, lower the position control lever all the way.
Mower (mid-and rear-mount type) Hayrake, tedder					NO		

TIRES, WHEELS AND BALLAST

TIRES



CAUTION

To avoid personal injury:

- Do not attempt mount a tire. This should be done by a qualified person with the proper equipment.

IMPORTANT:

- Do not use tires larger than specified.
- When you intend to mount different size of tires from equipped ones, consult your dealer about front drive gear ratio for detail.

Excessive wear of tires may occur due to improper gear ratio.

Inflation Pressure

Though the tire pressure is factory-set to the prescribed level, it naturally drops slowly in the course of time. Thus, check it everyday and inflate as necessary.

	Tire sizes	Inflation Pressure
Rear	11.2—24, 4PR	140 kPa (1.4 kgf/cm ² , 20 psi)
	12.4—24, 4PR	140 kPa (1.4 kgf/cm ² , 20 psi)
	13.6—16, 4PR	220 kPa (2.2 kgf/cm ² , 32 psi)
	13.6—24, 4PR	140 kPa (1.4 kgf/cm ² , 20 psi)
	14.9—24, 4PR	140 kPa (1.4 kgf/cm ² , 20 psi)
	41X14.00—20, 4PR	170 kPa (1.7 kgf/cm ² , 24 psi)
	355/80—D20, 4PR	100 kPa (1.0 kgf/cm ² , 14 psi)
	21.5L—16.1, 6PR	170 kPa (1.7 kgf/cm ² , 24 psi)
	420/70—24, 6PR	140 kPa (1.4 kgf/cm ² , 20 psi)
Front	17.5L—24, 6PR	140 kPa (1.4 kgf/cm ² , 20 psi)
	5.00—15, 4PR	220 kPa (2.2 kgf/cm ² , 32 psi)
	6.00—16, 4PR	220 kPa (2.2 kgf/cm ² , 32 psi)
	7.2—16, 4PR	150 kPa (1.5 kgf/cm ² , 22 psi)
	8.3—16, 4PR	150 kPa (1.5 kgf/cm ² , 22 psi)
	23X8.50—12, 4PR	150 kPa (1.5 kgf/cm ² , 22 psi)
	25X8.50—14, 4PR	70 kPa (0.7 kgf/cm ² , 1.0 psi)
	27X8.50—15, 4PR	85 kPa (0.9 kgf/cm ² , 12 psi)
	27X10.50—15, 4PR	85 kPa (0.9 kgf/cm ² , 12 psi)
	29X12.50—15, 4PR	140 kPa (1.4 kgf/cm ² , 20 psi)
10—16.5, 6PR	140 kPa (1.4 kgf/cm ² , 20 psi)	

NOTE:

- Maintain the maximum pressure in front tires, if using a front loader or when equipped with lots of front weight.

Dual Tires

Dual tires are not approved except for turf use.

WHEEL ADJUSTMENT



CAUTION

To avoid personal injury:

- When working on slopes or when working with trailer, set the wheel tread as wide as practical for maximum stability.
- Support tractor securely on stands before removing a wheel.
- Never operate tractor with a loose rim, wheel, or axle.

Front Wheels (with two wheel drive)

Front tread width can be adjusted as shown with the standard equipped tires.

To change the tread width

- Remove the front axle mounting bolts and the tie-rod mounting bolts.
- Move the front axles (right and left) to the desired position, and tighten the bolts.
- Adjust the toe-in: [2 to 8mm (0.1 to 0.3in.)]

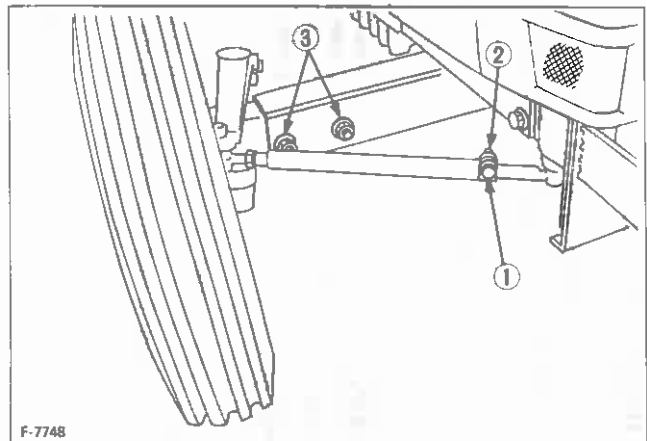

① Tie rod clamp

② Nut

③ Bolt 98N·m (10kgf·m/75ft·lbs)

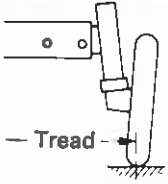
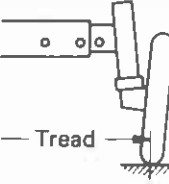
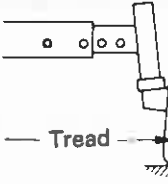
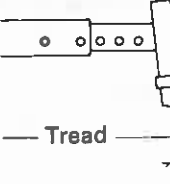
Models				
L2900 · L3300 5.00—15 Farm	960 mm (37.8 in.)	1060 mm (41.7 in.)	1160 mm (45.7 in.)	1260 mm (49.6 in.)
L3600 · L4200 6.00—16 Farm	1145 mm (45.1 in.)	1245 mm (49.0 in.)	1345 mm (53.0 in.)	1445 mm (56.9 in.)
L3600 5.00—15 Farm	1140 mm (44.9 in.)	1240 mm (48.8 in.)	1340 mm (52.8 in.)	1440 mm (56.7 in.)
L2900 · L3300 23×8.50—12 Turf	1080 mm (42.4 in.)	1180 mm (46.5 in.)	1280 mm (50.4 in.)	1380 mm (54.3 in.)
L2900 · L3300 25×8.50—14 Turf	1325 mm (52.2 in.)	1425 mm (56.1 in.)	1525 mm (60.0 in.)	1625 mm (64.0 in.)
L3600 25×8.50—14 Turf	1150 mm (45.3 in.)	1250 mm (49.2 in.)	1350 mm (53.1 in.)	1450 mm (57.1 in.)
L3600 · L4200 27×10.50—15 Turf	1195 mm (47.0 in.)	1295 mm (51.0 in.)	1395 mm (54.9 in.)	1495 mm (58.9 in.)
L3600 · L4200 29×12.50—15 Turf	1250 mm (49.2 in.)	1350 mm (53.1 in.)	1450 mm (57.1 in.)	1550 mm (61.0 in.)

IMPORTANT:

- The front tread width for the front loader application on 2WD models should not be greater than 1060mm (41.7 in.) for L2900·L3300, 1150mm (45.3 in.) for L3600·L4200.

Front Wheels (with four wheel drive)

Front tread can not be adjusted.

IMPORTANT:

- Do not turn front discs to obtain wider tread.

NOTE:

- Wheels with beveled or tapered holes: Use the tapered side of lug nut.

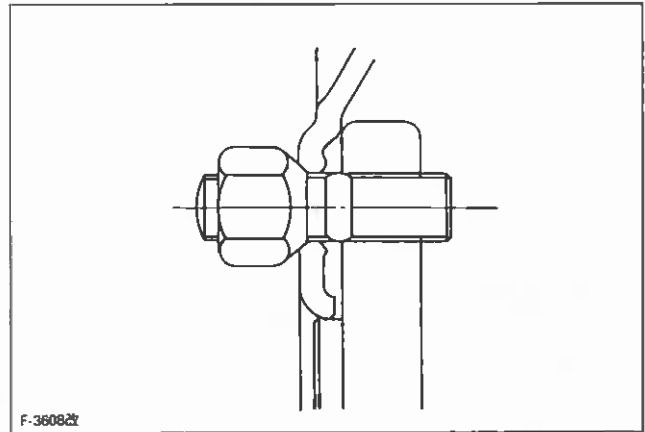

	Models	L2900 · L3300					
	Tires	7.2-16 Farm	25X8.50-14 Turf	27X8.50-15 Turf	27X10.50-15 Turf	29X12.50-15 Turf	10-16.5 IND
	Tread	1105 mm (43.5 in.)	1135 mm (44.7 in.)	1150 mm (45.3 in.)	1180 mm (46.5 in.)	1230 mm (48.4 in.)	1180 (46.5 in.)
	Models	L3600					
	Tires	7.2-16 Farm	8.3-16 Farm	27X8.50-15 Turf	27X10.50-15 Turf	29X12.50-15 Turf	10-16.5 IND
	Tread	1155 mm (45.5 in.)	1155 mm (45.5 in.)	1200 mm (47.2 in.)	1230 mm (48.4 in.)	1280 mm (50.4 in.)	1230 mm (48.4 in.)
	Models	L4200					
	Tires	—	8.3-16 Farm	27X8.50-15 Turf	27X10.50-15 Turf	29X12.50-15 Turf	10-16.5 IND
	Tread	—	1155 mm (45.5 in.)	1200 mm (47.2 in.)	1230 mm (48.4 in.)	1280 mm (50.4 in.)	1230 mm (48.4 in.)

NOTE:

- IND...for Industrial

■ Rear Wheels

Rear tread width can be adjusted as shown with the standard equipped tires.
To change the tread width

- (1) Remove the wheel rim and / or disk mounting bolts.
- (2) Change the position of the rim and / or disk (right and left) to the desired position, and tighten the bolts.

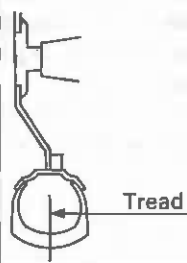
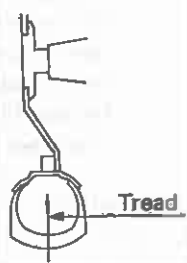
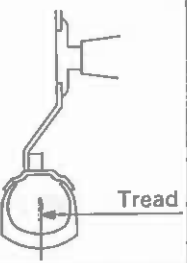
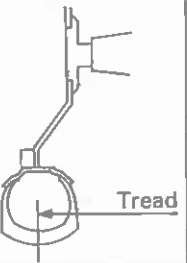
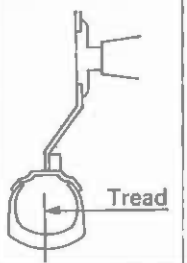
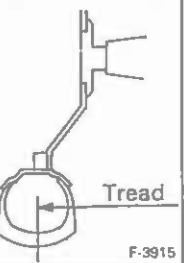
Models						
L2900 11.2-24 Farm	—	1035 mm (40.7 in.)	1120 mm (44.1 in.)	1220 mm (48.0 in.)	1305 mm (51.4 in.)	1405 mm (55.3 in.)
L2900 · L3300 12.4-24 Farm	—	—	1120 mm (44.1 in.)	1220 mm (48.0 in.)	1305 mm (51.4 in.)	1405 mm (55.3 in.)
L3600 12.4-24 Farm	1050 mm (41.3 in.)	1150 mm (45.3 in.)	1235 mm (48.6 in.)	1335 mm (52.6 in.)	1415 mm (55.7 in.)	1515 mm (59.6 in.)
L3600 · L4200 13.6-24 Farm	1080 mm (42.5 in.)	1180 mm (46.5 in.)	1200 mm (47.2 in.)	1300 mm (51.2 in.)	1450 mm (57.1 in.)	1545 mm (60.8 in.)
L3600 · L4200 14.9-24 Farm	—	1180 mm (46.5 in.)	1200 mm (47.2 in.)	1300 mm (51.2 in.)	1450 mm (57.1 in.)	1545 mm (60.8 in.)
L2900 · L3300 420/70-24 IND	—	—	—	1245 mm (49.0 in.)	1280 mm (50.4 in.)	1390 mm (54.7 in.)
L3600 · L4200 17.5L-24 IND	—	—	1245 mm (49.0 in.)	1355 mm (53.3 in.)	1395 mm (54.9 in.)	1505 mm (59.3 in.)

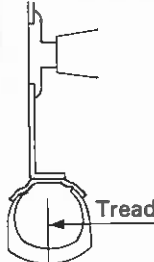
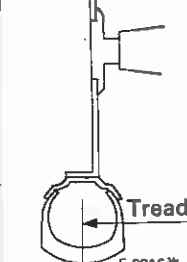
Models		
L2900 · L3300 13.6-16 Turf	—	1135 mm (44.7 in.)
L2900 · L3300 41×14.00-20 Turf	—	1150 mm (45.3 in.)
L3600 · L4200 41×14.00-20 Turf	1120 mm (44.1 in.)	1265 mm (49.8 in.)
L2900 · L3300 21.5L-16.1 Turf	—	1350 mm (53.1 in.)
L3600 · L4200 21.5L-16.1 Turf	—	1460 mm (57.5 in.)
L2900 · L3300 355/80-D20 Turf	—	1150 mm (45.3 in.)
L3600 · L4200 355/80-D20 Turf	1120 mm (44.1 in.)	1265 mm (49.8 in.)

IMPORTANT:

- Always attach tires as shown in the drawings.
- If not attached as illustrated, transmission parts may be damaged.
- When re-fitting or adjusting a wheel, tighten the bolts to the following torques then recheck after driving the tractor 200m (200yards) and thereafter daily check service.

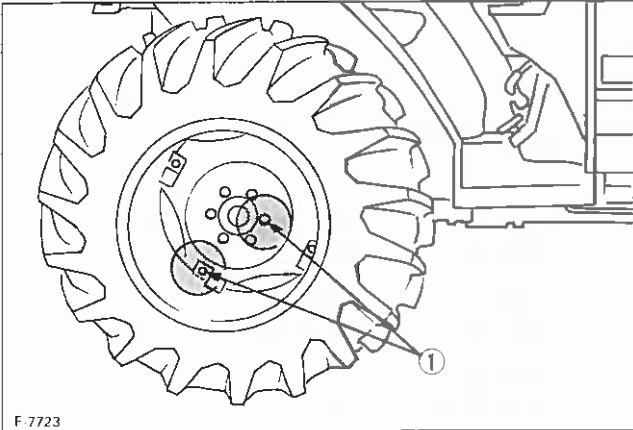

F-7723

① 215 N·m (22kgf·m, 160ft·lbs)

BALLAST



CAUTION

To avoid personal injury:

- Additional ballast will be needed for transporting heavy implements. When the implement is raised, drive slowly over rough ground, regardless of how much ballast is used.
- Do not fill the front wheel with liquid to maintain steering control.

■ Front Ballast

Add weights if needed for stability (2WD, 4WD models) and improve traction (4WD model). Heavy pulling and heavy rear mounted implements tend to lift front wheels. Add enough ballast to maintain steering control and prevent tip over. Remove weight when no longer needed.

◆ Front Wheel Weights (option) (2WD only)

The front wheel weights can be attached to the front wheel.

See your implement operator's manual or consult your local KUBOTA dealer to use.

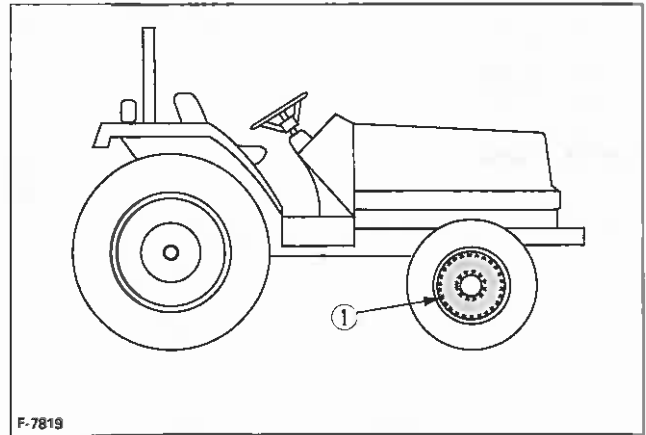

F-7819

① Front wheel weights

◆ **Front End Weights (option)**

The front end weights can be attached to the bumper.

See your implement operator's manual for required number of weights or consult your local KUBOTA dealer to use.

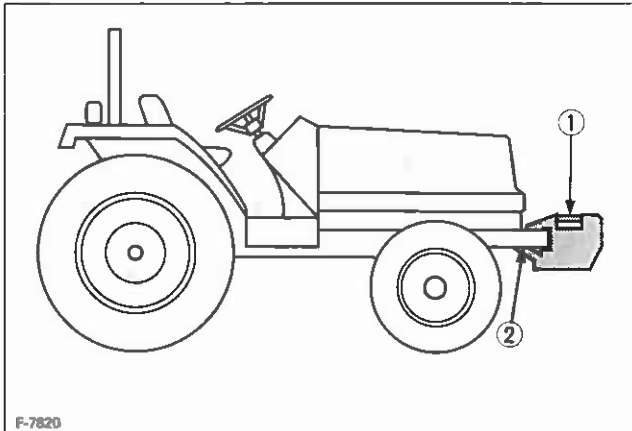

F-7820

- ① Front end weights
- ② Bumper

IMPORTANT:

- Do not overload tires.
- Add no more weight than indicated in chart.

Maximum weight	25 kg×5 Pieces (275 lbs.)
----------------	------------------------------

■ **Rear Ballast**

Add weight to rear wheels if needed to improve traction or for stability. The amount of rear ballast should be matched to job and the ballast should be removed when it is not needed.

The weight should be added to the tractor in the form of liquid ballast, rear wheel weights or a combination of both.

◆ **Rear Wheel Weights (option)**

The rear wheel weights can be attached to the rear wheel.

See your implement operator's manual for required number of weights or consult your local KUBOTA dealer to use.

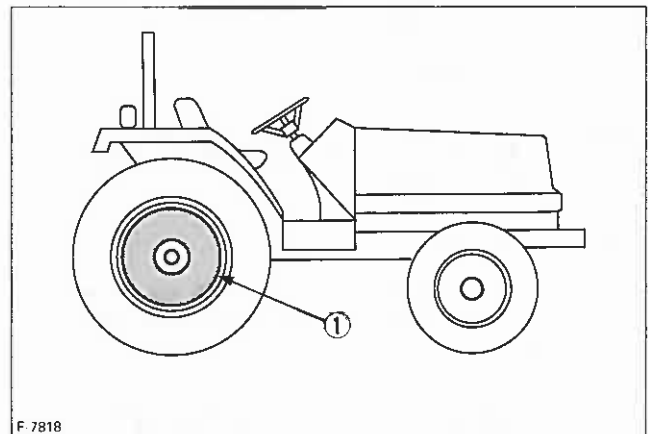

F-7818

- ① Rear wheel weights

IMPORTANT:

- Do not overload tires.
- Add no more weight than indicated in chart.

Maximum weight per wheel	28 kg×3 Pieces (185 lbs.)
--------------------------	------------------------------

◆ Liquid Ballast in Rear Tires

Water and calcium chloride solution provides safe economical ballast. Used properly, it will not damage tires, tubes or rims. The addition of calcium chloride is recommended to prevent the water from freezing.

Use of this method of weighting the wheels has the full approval of the tire companies. See your tire dealer for this service.

Liquid weight per tire (75 Percent filled)

Tire sizes	11.2-24	12.4-24	13.6-24
Slush free at -10°C (14°F)			
Solid at -30°C (-22°F) [Approx. 1 kg (2 lbs.) CaCl ₂ per 4 ℓ (1 gal) of water]	105 kg (230 lbs.)	130 kg (285 lbs.)	165 kg (365 lbs.)
Slush free at -24°C (-11°F)			
Solid at -47°C (-52°F) [Approx. 1.5 kg (3.5 lbs.) CaCl ₂ per 4 ℓ (1 gal) of water]	110 kg (240 lbs.)	135 kg (295 lbs.)	175 kg (385 lbs.)
Slush free at -47°C (-52°F)			
Solid at -52°C (-62°F) [Approx. 2.25 kg (5 lbs.) CaCl ₂ per 4 ℓ (1 gal) of water]	115 kg (253 lbs.)	145 kg (320 lbs.)	185 kg (405 lbs.)

Tire sizes	14.9-24	420/70-24	17.5L-24
Slush free at -10°C (14°F)			
Solid at -30°C (-22°F) [Approx. 1 kg (2 lbs.) CaCl ₂ per 4 ℓ (1 gal) of water]	205 kg (450 lbs.)	195 kg (430 lbs.)	235 kg (515 lbs.)
Slush free at -24°C (-11°F)			
Solid at -47°C (-52°F) [Approx. 1.5 kg (3.5 lbs.) CaCl ₂ per 4 ℓ (1 gal) of water]	215 kg (475 lbs.)	205 kg (450 lbs.)	250 kg (550 lbs.)
Slush free at -47°C (-52°F)			
Solid at -52°C (-62°F) [Approx. 2.25 kg (5 lbs.) CaCl ₂ per 4 ℓ (1 gal) of water]	225 kg (495 lbs.)	220 kg (485 lbs.)	265 kg (585 lbs.)

IMPORTANT:

- Do not fill tires with water or solution more than 75% of full capacity (to the valve stem level).
- Do not fill tires with water or solution if the tractor is a CAB model.

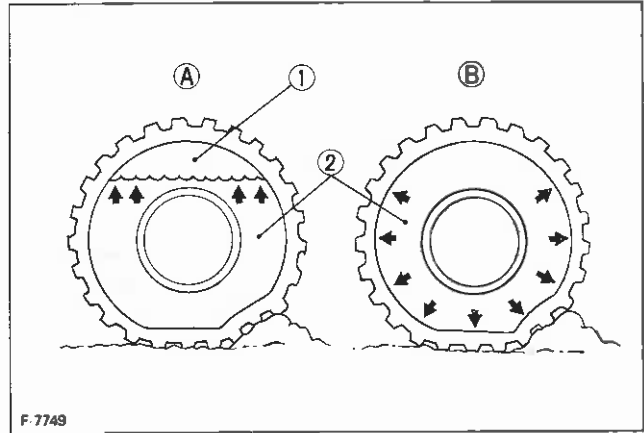

- F. 7749
- ① Air A Correct-75% Air compresses like a cushion
② Water B Incorrect-100% Full Water can not be compressed

MAINTENANCE

SERVICE INTERVALS

No.	Items	Period	Indication on hour meter																Since then	Reference page
			50	100	150	200	250	300	350	400	450	500	550	600	650	700	750	800		
1	Engine oil	Change	⊙	○		○		○		○		○		○		○		○	every 100 Hr	58
2	Engine oil filter	Replace	⊙			○				○								○	every 200 Hr	61
3	Hydraulic oil filter	Replace	⊙			○				○								○	every 200 Hr	61
4	Transmission fluid	Change	⊙							○								○	every 400 Hr	63
5	Front axle case oil	Change	⊙							○								○	every 400 Hr	64
6	Front axle pivot	Adjust	⊙							○								○	every 400 Hr	64
7	Greasing		○	○	○	○	○	○	○	○	○	○	○	○	○	○	○	○	every 50 Hr	54, 55
8	Engine start system	Check	○	○	○	○	○	○	○	○	○	○	○	○	○	○	○	○	every 50 Hr	55
9	Wheel bolt torque	Check	○	○	○	○	○	○	○	○	○	○	○	○	○	○	○	○	every 50 Hr	56
10	Battery condition	Check	○	○	○	○	○	○	○	○	○	○	○	○	○	○	○	○	every 50 Hr	56
11	Air cleaner element	Clean		○		○		○		○		○		○		○		○	every 100 Hr*	58
		Replace																	every 1 year	65
12	Fuel filter element	Clean		○		○		○		○		○		○		○		○	every 100 Hr	59
		Replace								○									○	every 400 Hr
13	Fan belt	Adjust		○		○		○		○		○		○		○		○	every 100 Hr	59
14	Clutch	Adjust		○		○		○		○		○		○		○		○	every 100 Hr	60
15	Brake	Adjust		○		○		○		○		○		○		○		○	every 100 Hr	60
16	Radiator hose and clamp	Check				○				○								○	every 200 Hr	62
		Replace																	every 2 years	66
17	Power steering oil line	Check				○				○								○	every 200 Hr	62
		Replace																	every 2 years	66
18	Fuel line	Check				○				○								○	every 200 Hr	62
		Replace																	every 2 years	60
19	Toe-in	adjust				○				○								○	every 200 Hr	63
20	Greasing (2WD front wheel hub)									○								○	every 400 Hr	65
21	Engine valve clearance	Adjust																○	every 800 Hr**	65
22	Cooling system	Flush																	every 2 years	65
23	Coolant	Change																	every 2 years	65
24	Fuel system	Bleed																		66
25	Clutch housing water	Drain																	Service as required	67
26	Fuse	Replace																		67
27	Light bulb	Replace																		68

IMPORTANT

- The jobs indicated by ⊙ must be done by all means 50 hours after the break-in respectively.
- * Air cleaner should be cleaned more often in dusty conditions than in normal conditions.
- ** Consult your local KUBOTA dealer for this service.

LUBRICANTS

No.	Locations	Capacities				Lubricants						
		L2900	L3300	L3600	L4200							
1	Fuel	35 ℓ (9.2 U.S.gals.)				No.2-D diesel fuel No.1-D diesel fuel if temperature is below -10°C (14°F)						
2	Coolant	7.0 ℓ (7.4 U.S.qts.)		7.5 ℓ (7.9 U.S.qts.)		Fresh clean water with anti-freeze						
3	Engine crankcase	3.5 ℓ (3.7 U.S.qts.)		6.0 ℓ (6.3 U.S.qts.)		<ul style="list-style-type: none"> Engine oil: API Service Classification CC or CD <table border="1" style="width: 100%; border-collapse: collapse;"> <tr> <td style="padding: 2px;">Above 25°C (77°F)</td> <td style="padding: 2px;">SAE30, SAE10W-30 or 10W-40</td> </tr> <tr> <td style="padding: 2px;">0 to 25°C (32 to 77°F)</td> <td style="padding: 2px;">SAE20, SAE10W-30 or 10W-40</td> </tr> <tr> <td style="padding: 2px;">Below 0°C (32°F)</td> <td style="padding: 2px;">SAE10W, SAE10W-30 or 10W-40</td> </tr> </table>	Above 25°C (77°F)	SAE30, SAE10W-30 or 10W-40	0 to 25°C (32 to 77°F)	SAE20, SAE10W-30 or 10W-40	Below 0°C (32°F)	SAE10W, SAE10W-30 or 10W-40
Above 25°C (77°F)	SAE30, SAE10W-30 or 10W-40											
0 to 25°C (32 to 77°F)	SAE20, SAE10W-30 or 10W-40											
Below 0°C (32°F)	SAE10W, SAE10W-30 or 10W-40											
4	Transmission case	39.0 ℓ (41.2 U.S.qts.)				<i>Multi Purpose</i> <ul style="list-style-type: none"> KUBOTA SUPER UDT fluid* 						
5	Front axle case [4WD]	5.5 ℓ (5.8 U.S.qts.)				<ul style="list-style-type: none"> KUBOTA SUPER UDT Oil or SAE 80-SAE 90 gear oil 						
6	Greasing	No. of greasing points				Capacity	Type of grease					
	Front wheel hub [2WD]	2				Until grease overflows.	Multipurpose type grease					
	Knuckle shaft [2WD]	2										
	Top link	2						1				
	Top link bracket	2 [with Draft Control (if equipped)]										
	Lift rod	1										
	Power steering cylinder	1										
	Battery terminal	2						moderate amount				

NOTE: * KUBOTA SUPER UDT...KUBOTA Original Transmission hydraulic fluid

NOTE:

- **Engine Oil:**
Oil used in the engine should have an American Petroleum Institute (API) service classification and Proper SAE Engine Oil according to the ambient temperatures as shown above:

- **Transmission oil:**
The oil used to lubricate the transmission is also used as hydraulic fluid. To insure proper operation of the hydraulic system and complete lubrication of the transmission, it is important that a multi-grade transmission fluid be used in this system. We recommend the use of **KUBOTA SUPER UDT** fluid for optimum protection and performance. (Consult your local KUBOTA dealer for further detail.)
Do not mix different brands together.

- Indicated capacity of water and oil are manufacture's estimate.

PERIODIC SERVICE

HOW TO OPEN THE HOOD



CAUTION

To avoid personal injury from contact with moving parts;

- Never open the front grill or engine side cover while the engine is running.
- Do not touch muffler or exhaust pipes while they are hot; Severe burns could result.

■ Engine Side Cover and Front Grill

(1) To remove the front grill, twist the mascot to release the latch.

Before removing it, disconnect the head light harness at the connector.

(2) To remove the engine side cover, twist the handle to release the latch, and then lift the engine side cover off.

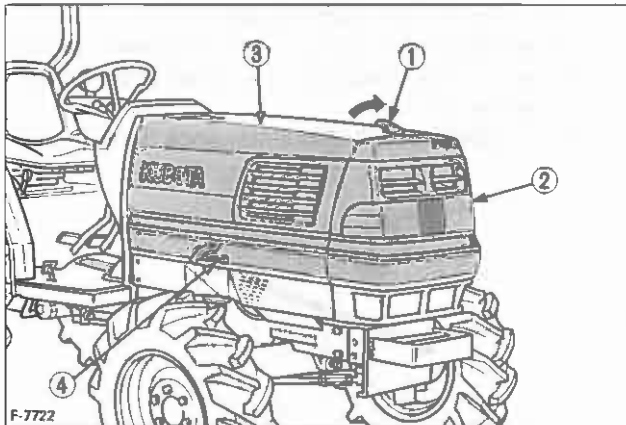

- F-7722
- ① Mascot
 - ② Front grill
 - ③ Engine side cover
 - ④ Lock handle

DAILY CHECK

For your own safety and maximum service life of the machine, make a thorough daily inspection before operating the machine to start the engine.



CAUTION

To avoid personal injury:

- Be sure to check and service the tractor on a flat place with the engine shut off and the parking brake "ON".

■ Walk Around Inspection

Look around and under the tractor for such items as loose bolts, trash build-up, oil or coolant leaks, broken or worn parts.

■ Checking and Refueling



CAUTION

To avoid personal injury:

- Do not smoke while refueling.
- Be sure to stop the engine before refueling.

(1) Turn the key switch to "ON", check the amount of fuel by fuel gauge.

(2) Fill fuel tank when fuel gauge shows 1/4 or less fuel in tank.

(3) Use grade No.2-Diesel fuel at temperatures above 4°C.

Use grade No.1-Diesel fuel at temperatures below 4°C.

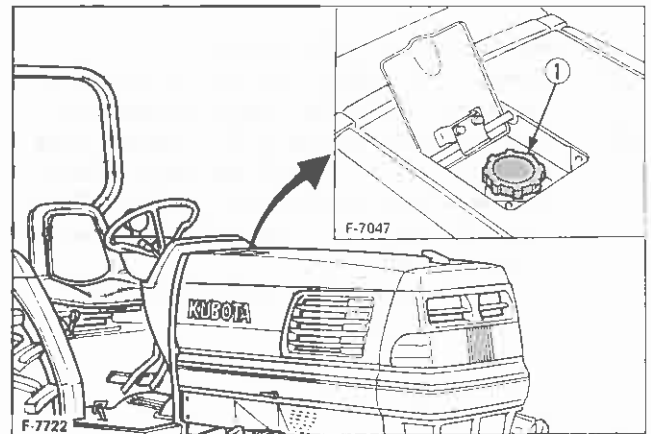

- F-7722
- ① Fuel tank cap

Fuel tank capacity

35 ℓ (9.2 U.S.gals.)

IMPORTANT:

- Do not permit dirt or trash to get into the fuel system.
- Be careful not to let the fuel tank become empty, or air can enter the fuel system, necessitating bleeding before next engine start.
- Be careful not to spill during refueling. If should spill, wipe it off at once, or it may cause a fire.

NOTE:

No.2-D A distillate fuel of lower volatility for engines in industrial and heavy mobile service.

(SAE J313 JUN87)

Grade of Diesel Fuel Oil According to ASTM D975

Flash Point, °C (°F)	Water and Sediment, volume %	Carbon Re- sidue on, 10 percent Re- sidual, %	Ash, weight %
Min	Max	Max	Max
52 (125)	0.05	0.35	0.01

Distillation Tempera- tures, °C (°F) 90% Point		Viscosity Kinematic cSt or mm ² /s at 40°C		Viscosity Saybolt, SUS at 100°F		Sulfur, weight %	Copper Strip Corro- sion	Cetane Num- ber
Min	Max	Min	Max	Min	Max	Max	Max	Min
282 (540)	338 (640)	1.9	4.1	32.6	40.1	0.50	No.3	40

■ Checking Engine Oil Level

**CAUTION**

To avoid personal injury:

- Be sure to stop the engine before checking the oil level.

- (1) Park the machine on a flat surface.
- (2) Check engine oil before starting the engine or 5 minutes or more after the engine has stopped.
- (3) To check the oil level, draw out the dipstick, wipe it clean, replace it, and draw it out again. Check to see that the oil level lies between the two notches. If the level is too low, add new oil to the prescribed level at the oil inlet.
(See "LUBRICANTS" in Maintenance Section)

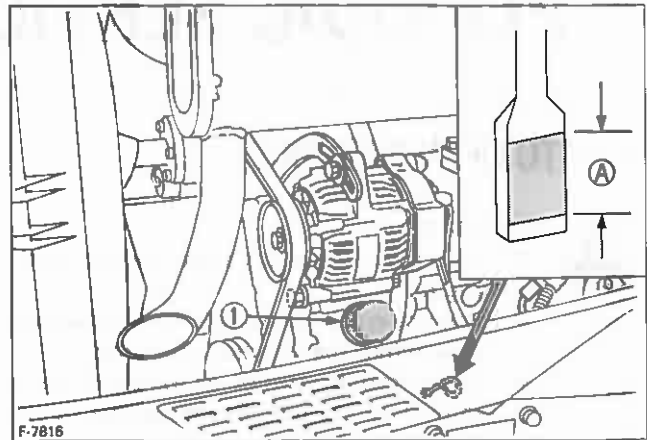

① Oil inlet A Oil level is acceptable within this range.

IMPORTANT:

- When using an oil of different maker or viscosity from the previous one, remove all of the old oil. Never mix two different types of oil.
- If oil level is low, do not run engine.

■ Checking Transmission Fluid Level

- (1) Park the machine on a flat surface, lower the implement and shut off engine.
- (2) View the fluid level through the fluid level gauge. If the level is too low, add new oil to the prescribed level at the oil inlet.
(See "LUBRICANTS" in Maintenance Section)

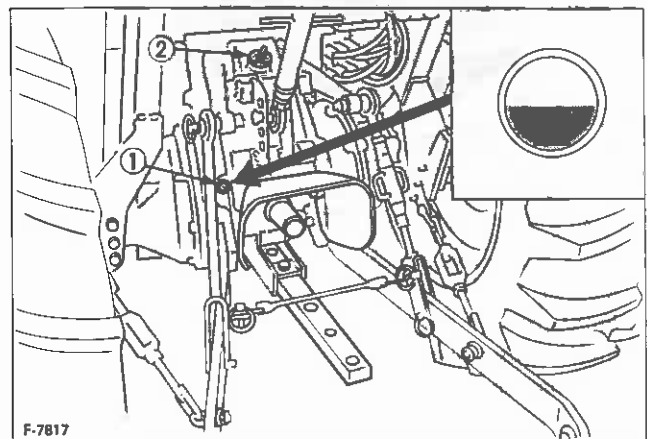

① Gauge
② Oil filling plug

IMPORTANT:

- If oil level is low, do not run engine.

■ Checking Coolant Level



CAUTION

To avoid personal injury:

- Do not remove the radiator cap when the engine is hot. Then loosen cap slightly to the stop to relieve any excess pressure before removing cap completely.

- (1) Check to see that the coolant level is between the "FULL" and "LOW" marks of recovery tank.
- (2) When the coolant level drops due to evaporation, add water only up to the full level.
In case of leakage, add anti-freeze and water in the specified mixing ratio up to the full level.
(See "Flush Cooling System and Changing Coolant" in every 2 years maintenance.)

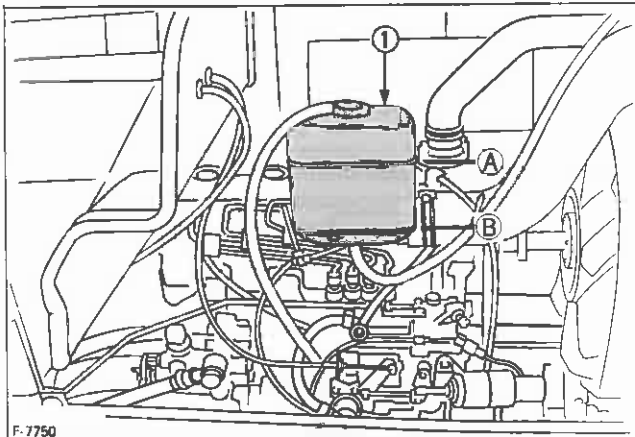

① Recovery tank

Ⓐ "FULL"

Ⓑ "LOW"

IMPORTANT:

- If the radiator cap has to be removed, follow the caution above and securely retighten the cap.
- Use clean, fresh water and anti-freeze to fill the recovery tank.
- If water should be leak, consult your local KUBOTA dealer.

■ Cleaning Grill and Radiator Screen



CAUTION

To avoid personal injury:

- Be sure to stop the engine before removing the screen.

- (1) Check front grill and side screens to be sure they are clean from debris.
- (2) Detach the screen and remove all the foreign material.

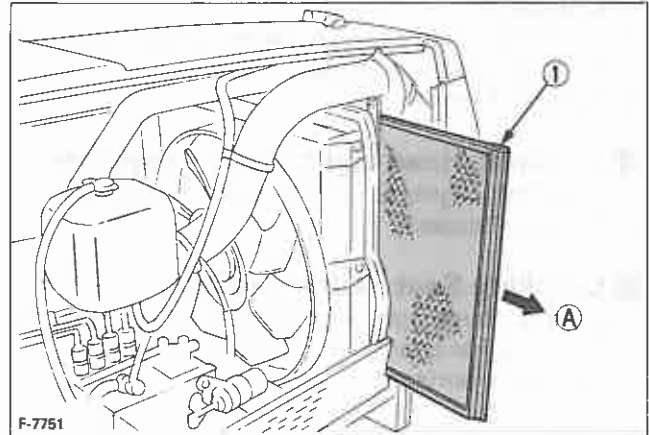

① Radiator screen

Ⓐ "DETACH"

IMPORTANT:

- Grill and screen must be clean from debris to prevent engine from overheating and to allow good air intake for air cleaner.

NOTE:

- If the dust or chaff is accumulated between the battery and radiator, open the shutter plate and clean the front of radiator completely.

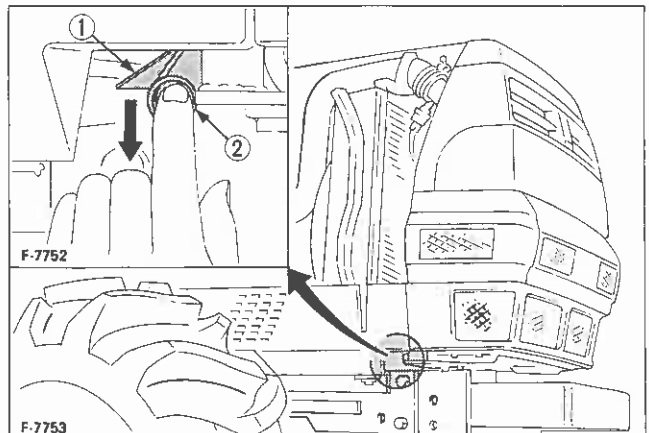

① Shutter

② Spring

■ Checking Brake Pedals and Clutch Pedal

- (1) Inspect the brake and clutch pedals for free travel, and smooth operation.
- (2) Adjust if incorrect measurement is found:
(See "Adjusting Clutch and Brake Pedal" in every 100 hours maintenance.)

NOTE:

- Brake pedals should be equal when depressed.

■ Checking Gauges, Meter and Easy Checker™

- (1) Inspect the instrument panel for broken gauge(s), meter(s) and Easy Checker™ lamps.
- (2) Replace if broken.

■ Checking Head Light, Hazard Light etc.

- (1) Inspect the lights for broken bulbs and lenses.
- (2) Replace if broken.

■ Checking Seat Belt and ROPS

- (1) Always check condition of seat belt and ROPS attaching hardware before operating tractor.
- (2) Replace if damaged.

EVERY 50 HOURS

■ Lubricating Grease Fittings

Apply a small amount of multipurpose grease to the following points every 50 hours:

If you operated the machine in extremely wet and muddy conditions, lubricate grease fittings more often.

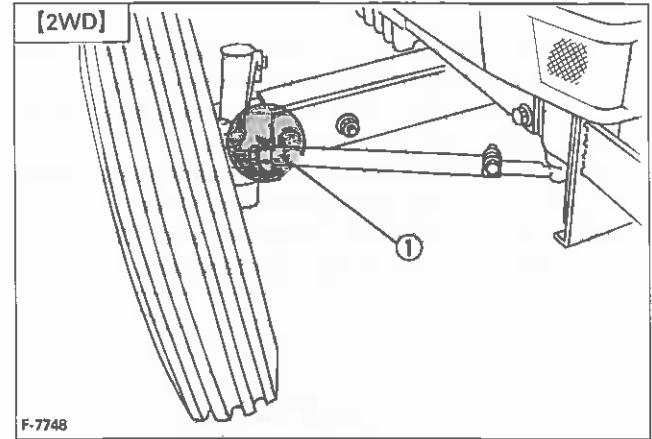

① Grease fitting (Knuckle shaft) [RH, LH]

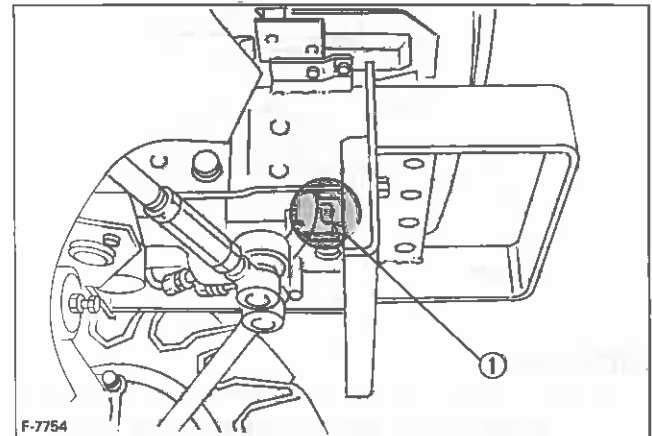

① Grease fitting (Power steering cylinder)

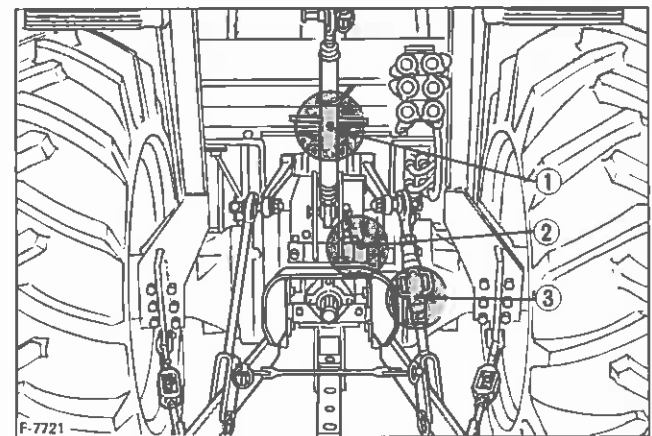

- ① Grease fitting (Top link)
- ② Grease fitting (Top link bracket)
- ③ Grease fitting (Lifting rod) [RH]

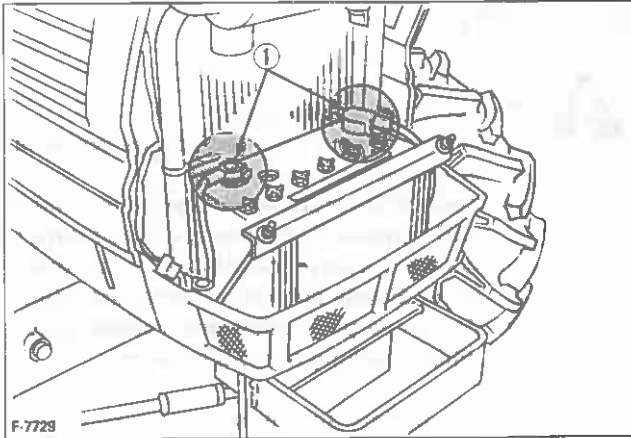

① Battery terminals

■ Checking Engine Start System



CAUTION

To avoid personal injury:

- Do not allow anyone near the tractor while testing.
- If the tractor does not pass the test do not operate the tractor.

◆ Preparation before testing.

1. Place all control levers in the "NEUTRAL" position.
2. Set the parking brake and stop the engine.

◆ Test 1 : Switch for the shuttle shift lever.

1. Sit on operator's seat.
2. Shift the shuttle shift lever to the forward or reverse position.
3. Depress the clutch pedal fully.
4. Disengage the PTO gear shift lever or PTO clutch control lever.
5. Pull out the engine stop knob and turn the key to "START" position.
6. The engine must not crank.
7. If it cranks, consult your local KUBOTA dealer for this service.

◆ Test 2 : Switch for the PTO gear shift lever or PTO clutch control lever.

1. Sit on operator's seat.
2. Engage the PTO gear shift lever or PTO clutch control lever.
3. Depress the clutch pedal fully.
4. Shift the shuttle shift lever to the neutral position.
5. Pull out the engine stop knob and turn the key to "START" position.
6. The engine must not crank.
7. If it cranks, consult your local KUBOTA dealer for this service.

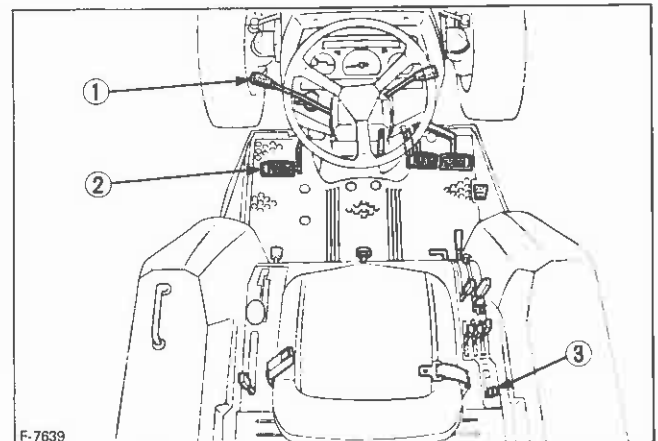

① Shuttle shift lever

② Clutch pedal

③ PTO gear shift lever / PTO clutch control lever

■ Checking Wheel Bolt Torque



CAUTION

To avoid personal injury:

Never operate tractor with a loose rim, wheel, or axle.

- Any time bolts and nuts are loosened, retighten to specified torque.
- Check all bolts and nuts frequently and keep them tight.

Check wheel bolts and nuts regularly especially when new. If there are loosend,tighten as follows.

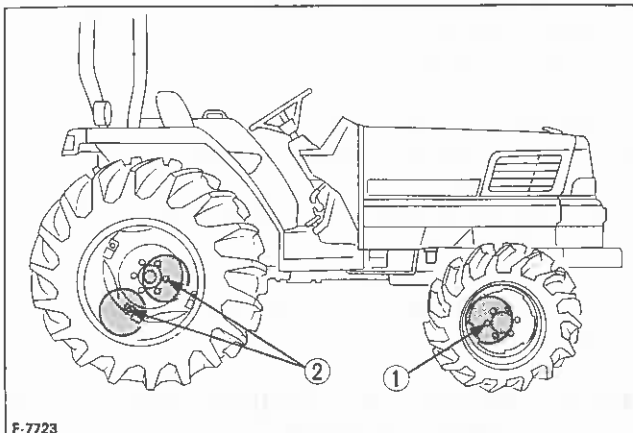

F-7723

① 137 N·m (14kgf·m, 100ft·lbs)

② 215 N·m (22kgf·m, 160ft·lbs)

■ BATTERY



CAUTION

To avoid personal injury:

- Never remove the vent plugs while the engine is running.
- Keep electrolyte away from eyes, hands and clothes. If you are splattered with it, wash it away completely with water immediately and get medical attention.
- Wear eye protection and rubber gloves when working around battery.

Mishandling the battery shortens the service life and adds to maintenance costs.

The original battery is maintenance free type battery, but need some servicing.

If the battery is weak, the engine is difficult to start and the lights become dim. It is important to check the battery periodically.

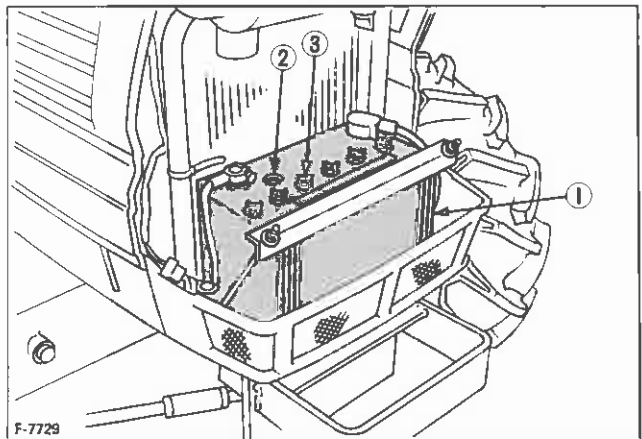

F-7729

① Battery

② Indicator

③ Vent plug

◆ How to read the indicator

Check the battery condition by reading the indicator.

State of indicator display

Blue: Specific gravity of electrolyte and quantity of electrolyte are both in good condition

White: Needs inspecting(Sequence of inspection):

- (1) Add only distilled water if the electrolyte level is low. (Proper level is shown in Fig.1) You can start work again if the indicator display turns to blue. Charge battery if the indicator display remains white. (Normal charging rate is shown in table 1)
- (2) Charge battery if the electrolyte level is normal.

◆ **Battery Charging**



CAUTION

To avoid personal injury:

- When the battery is being activated, hydrogen and oxygen gases in the battery are extremely explosive. Keep open sparks and flames away from the battery at all times, especially when charging the battery.
- When charging battery, remove battery vent plugs.
- When disconnecting the cable from the battery, start with the negative terminal first.
When connecting the cable to the battery, start with the positive terminal first.
- Never check battery charge by placing a metal object across the posts.
Use a voltmeter or hydrometer.

- (1) Make sure each electrolyte level is to the bottom of vent wells, if necessary add distilled water in a well-ventilated area.

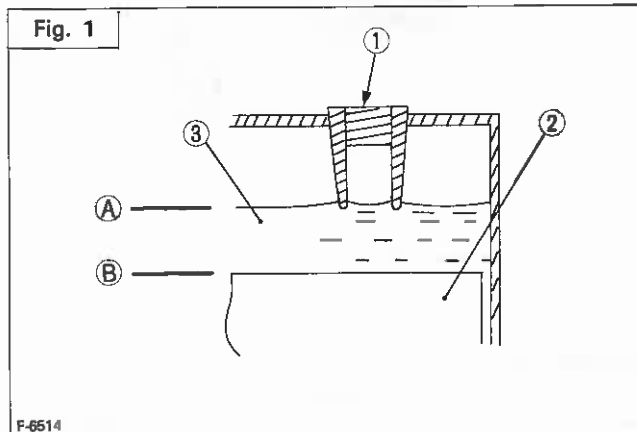

- ① Vent well
- ② Separator
- ③ Electrolyte
- Ⓐ Highest level
- Ⓑ Lowest level

- (2) The water in the electrolyte evaporates during recharging. Liquid shortage damages the battery. Excessive liquid spills over and damages the tractor body.
- (3) To slow charge the battery, connect the battery positive terminal to the charger positive terminal and the negative to the negative, then recharge in the standard fashion.
- (4) A boost charge is only for emergencies. It will partially charge the battery at a high rate and in a short time.
When using a boost-charged battery, it is necessary to recharge the battery as early as possible.
Failure to do this will shorten the battery's service life.

- (5) When the specific gravity of electrolyte become between 1.27 and 1.29 charge has completed.
- (6) When exchanging an old battery into new one, use battery of equal specification shown in table 1.

Table 1

Tractor model	Battery TYPE	Volts (v)	Capacity at 5H.R (A.H)
L2900 L3300	75D26R-MF	12	52
L3600 L4200	75D31R-MF	12	60

Tractor model	Reserve Capacity (min)	Cold Cranking Amps	Normal Charging Rate (A)
L2900 L3300	123	490	5.2
L3600 L4200	137	447	6.0

◆ **Direction for Storage**

- (1) When storing the tractor for long periods of time, remove the battery from tractor, adjust the electrolyte to the proper level and store in a dry place out of direct sunlight.
- (2) The battery self-discharges while it is stored. Recharge it once every three months in hot seasons and once every six months in cold seasons.

EVERY 100 HOURS

■ Changing Engine Oil



CAUTION

To avoid personal injury:

- Be sure to stop the engine before changing the oil.
- Allow engine to cool down sufficiently, oil can be hot and can burn.

(1) To drain the used oil, remove the drain plug at the bottom of the engine and drain the oil completely into the oil pan.

All the used oil can be drained out easily when the engine is still warm.

(2) After draining reinstall the drain plug.

(3) Fill with the new oil up to the upper notch on the dipstick.

(See "LUBRICANTS" in Maintenance Section)

Oil capacity with filter	L2900 · L3300	3.5 ℓ (3.7 U.S.qts.)
	L3600 · L4200	6.0 ℓ (6.3 U.S.qts.)

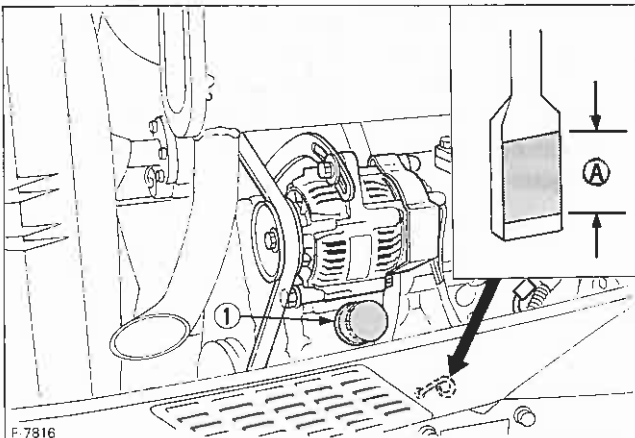

① Oil inlet A Oil level is acceptable within this range

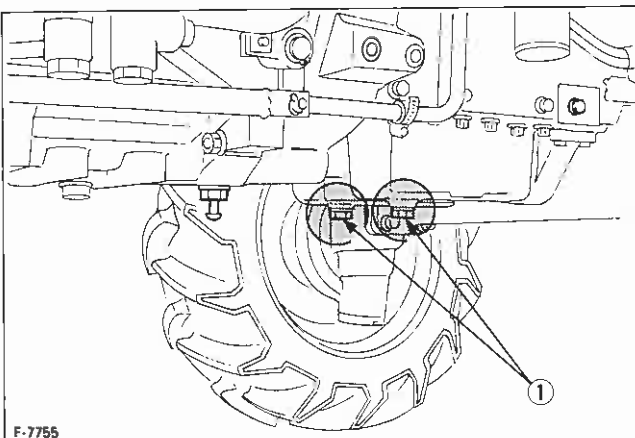

① Drain plug

■ Cleaning Air Cleaner Element

(1) Remove the element.

(2) Clean the element:

1) When dry dust adheres to the element, blow compressed air from the inside turning the element. Pressure of compressed air must be under 686kPa (7kgf/cm², 99 psi).

2) When carbon or oil adheres to the element, soak the element in detergent for 15 minutes then wash it several times in water, rinse with clean water and dry it naturally. After element is fully dried, inspect inside of the element with a light and check if it is damaged or not. (referring to the instructions on the label attached to the element.)

(3) Replace air cleaner element if:

Once yearly or after every sixth cleaning, whichever comes first.

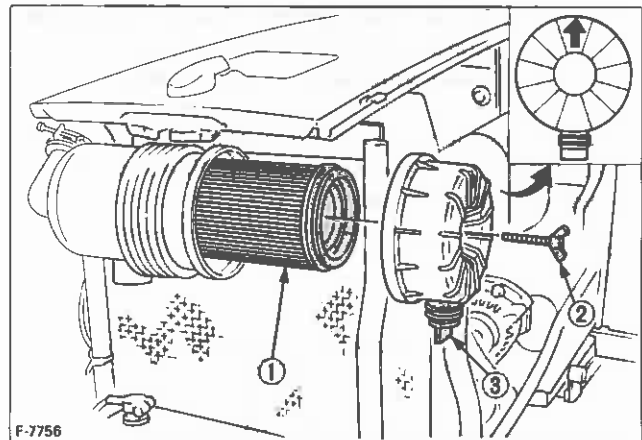

① Element
② Wing bolt
③ Evacuator valve

IMPORTANT:

- The air cleaner uses a dry element, never apply oil.
- Do not run the engine with filter element removed.
- Make sure the wing nut or bolt with rubber dust seal for the element is tight enough. If it is loose, dust and dirt may be sucked in, wearing down the cylinder and piston rings earlier and thereby resulting in poor power output.
- Be sure to refit the dust cup with the arrow ↑ (on the rear) upright. If the dust cup is improperly fitted, dust passes by the baffle and directly adheres to the element.

◆ Evacuator Valve

Open the evacuator valve once a week under ordinary conditions - or daily when used in a dusty place - to get rid of large particles of dust and dirt.

■ Cleaning Fuel Filter

This job should not be done in the field, but in a clean place.

- (1) Close the fuel filter cock.
- (2) Unscrew the screw ring and remove the filter bowl, and rinse the inside with kerosene.
- (3) Take out the element and dip it in the kerosene to rinse.
- (4) After cleaning, reassemble the fuel filter, keeping out dust and dirt.
- (5) Bleed the fuel system.
(See "Bleeding Fuel System" in as required maintenance)

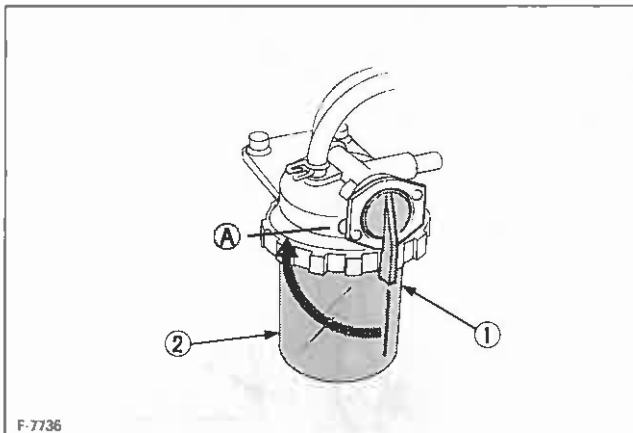

- F-7736
- ① Fuel cock
 - ② Fuel filter bowl
- A "CLOSE"

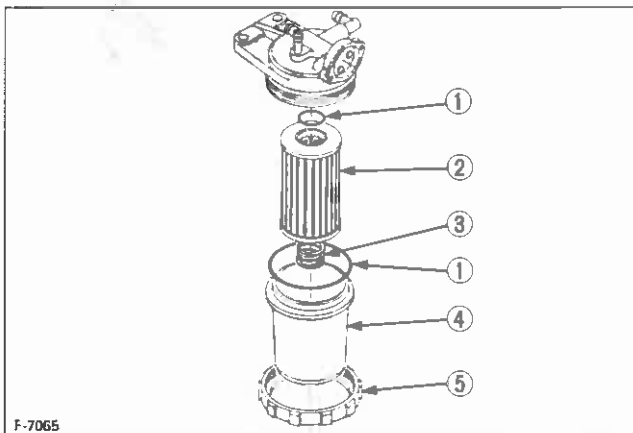

- F-7065
- ① O ring
 - ② Filter element
 - ③ Spring
 - ④ Filter bowl
 - ⑤ Screw ring

IMPORTANT:

- If dust and dirt enters the fuel system, the fuel pump and injection nozzles are subject to premature wear. To prevent this, be sure to clean the fuel filter bowl periodically.

■ Adjusting Fan Belt Tension



CAUTION

To avoid personal injury:

- Be sure to stop the engine before checking belt tension.

Proper fan belt tension

A deflection of between 7 to 9 mm (0.28 to 0.34 in.) when the belt is pressed in the middle of the span.

- (1) Stop the engine and remove the key.
- (2) Apply moderate thumb pressure to belt between pulleys.
- (3) If tension is incorrect, loosen the alternator mounting bolts and, using a lever placed between the alternator and the engine block, pull the alternator out until the deflection of the belt falls within acceptable limits.
- (4) Replace fan belt if it is damaged.

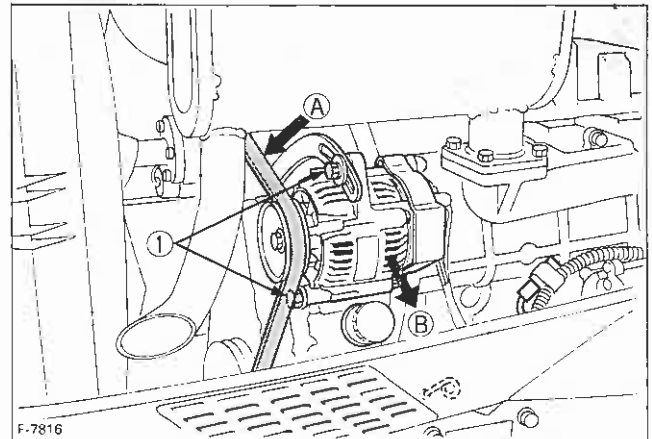

- F-7816
- ① Bolt
 - A Check the belt tension
 - B To tighten

■ Adjusting Clutch Pedal

Proper clutch pedal free travel	20 to 30 mm (0.8 to 1.2 in.) on the pedal
---------------------------------	---

- (1) Stop the engine and remove the key.
- (2) Slightly depress the clutch pedal and measure free travel at top of pedal stroke.
- (3) If adjustment is needed, loosen the lock nut, remove the clevis pin and adjust the rod length within acceptable limits.
- (4) Retighten the lock nut and split the cotter pin.

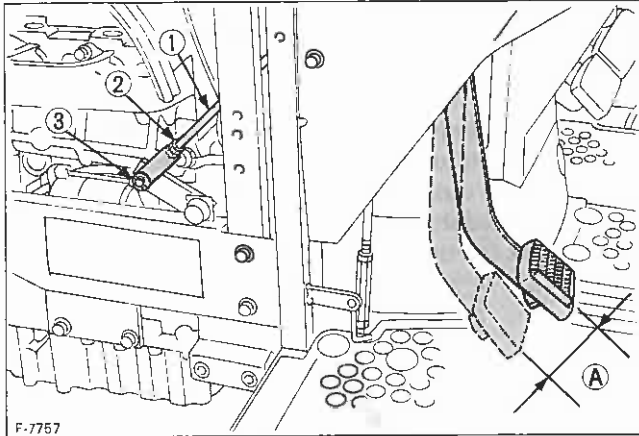

- ① Clutch rod
- ② Nut
- ③ Clevis pin

Ⓐ Free travel

■ Adjusting Brake Pedal



CAUTION

To avoid personal injury:

- Stop the engine and chock the wheels before checking brake pedal.

Proper brake pedal free travel	15 to 20 mm (0.6 to 0.8 in.) on the pedal.
	Keep the free travel in the right and left brake pedals equal.

- (1) Release the parking brake.
- (2) Slightly depress the brake pedals and measure free travel at top of pedal stroke.
- (3) If adjustment is needed, loosen the lock nut and turn the turnbuckle to adjust the rod length within acceptable limits.
- (4) Retighten the lock nut.

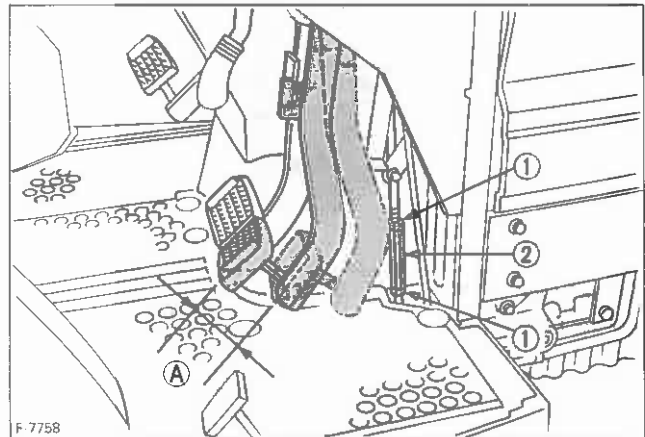

① Lock nut

② Turnbuckle

Ⓐ Free travel

EVERY 200 HOURS

■ Replacing Engine Oil Filter



CAUTION

To avoid personal injury:

- Be sure to stop the engine before changing the oil filter cartridge.
- Allow engine to cool down sufficiently, oil can be hot and can burn.

- (1) Remove the oil filter.
- (2) Put a film of clean engine oil on rubber seal of new filter
- (3) Tighten the filter quickly until it contacts the mounting surface.
Tighten filter by hand an additional 1/2 turn only.
- (4) After the new filter has been replaced, the engine oil normally decreases a little. Make sure that the engine oil does not leak through the seal and be sure to check the oil level on the dipstick. Then, replenish the engine oil up to the prescribed level.

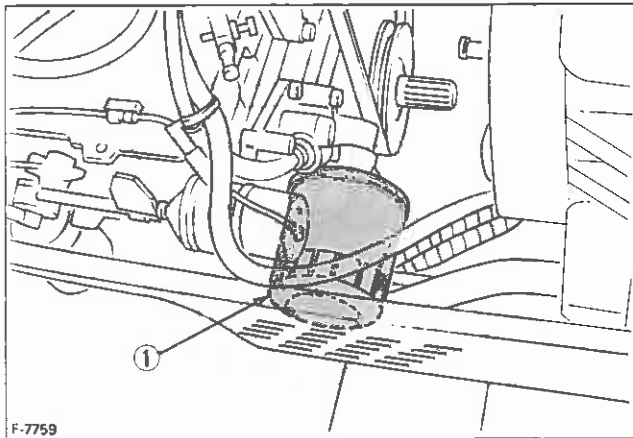

F-7759

① Engine oil filter

IMPORTANT:

- To prevent serious damage to the engine, use only a genuine KUBOTA filter.

■ Replacing Hydraulic Oil Filter



CAUTION

To avoid personal injury:

- Allow engine to cool down sufficiently, oil can be hot and can burn.

- (1) Remove the oil filter.
- (2) Put a film of clean transmission oil on rubber seal of new filter.
- (3) Tighten the filter quickly until it contacts the mounting surface.
Tighten filter by hand an additional 1/2 turn only.
- (4) After the new filter has been replaced, the transmission fluid level will decrease a little. Make sure that the transmission fluid does not leak through the seal, and check the fluid level.
Top up if necessary.

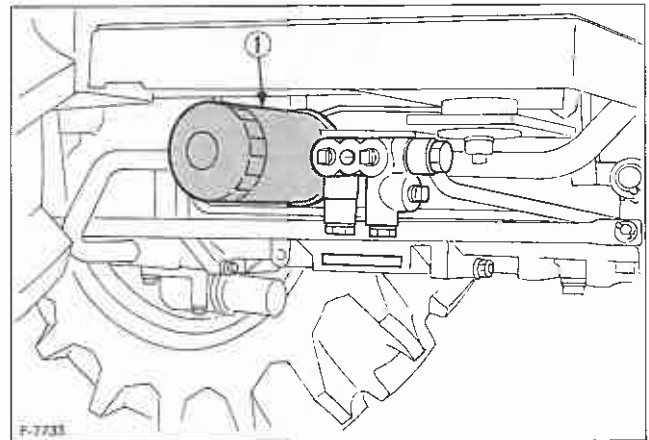

F-7733

① Hydraulic oil filter

IMPORTANT:

- To prevent serious damage to the hydraulic system, use only a genuine KUBOTA filter.

■ Checking Radiator Hose and Clamp

Check to see if radiator hoses are properly fixed every 200 hours of operation or six months, whichever comes first.

- (1) If hose clamps are loose or water leaks, tighten bands securely.
- (2) Replace hoses and tighten hose clamps securely, if radiator hoses are swollen, hardened or cracked.

Replace hoses and hose clamps every 2 years or earlier if checked and found that hoses are swollen, hardened or cracked.

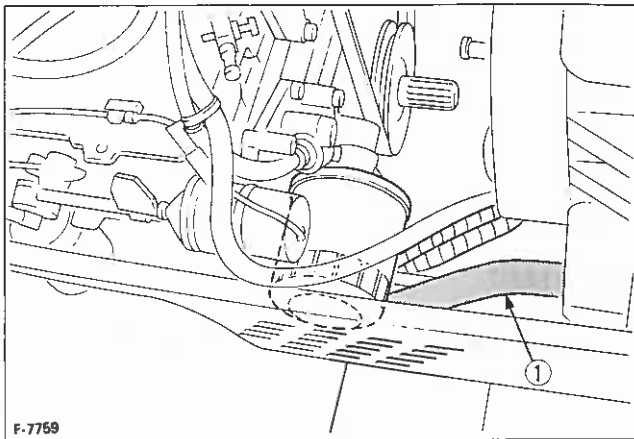
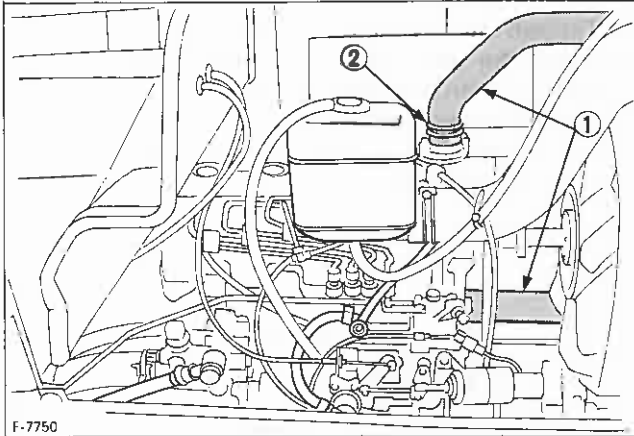

- ① Radiator hoses
- ② Clamp bands

◆ Precaution at Overheating

Take the following actions in the event the coolant temperature be nearly or more than the boiling point, what is called "Overheating"

- (1) Stop the machine operation in a safe place and keep the engine unloaded idling.
- (2) Don't stop the engine suddenly, but stop it after about 5 minutes of unloaded idling.
- (3) Keep yourself well away from the machine for further 10 minutes or while the steam blown out.
- (4) Checking that there gets no danger such as burn, get rid of the causes of overheating according to the manual, see "Troubleshooting" section, And then, start again the engine.

■ Checking Power Steering Line

■ Checking Fuel Line

- (1) Check to see that all lines and hose clamps are tight and not damaged.
- (2) If hoses and clamps are found worn or damaged, replace or repair them at once.

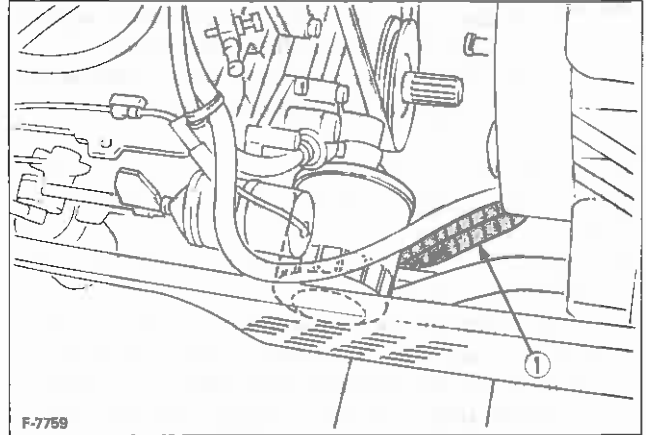

- ① Power steering pressure hoses

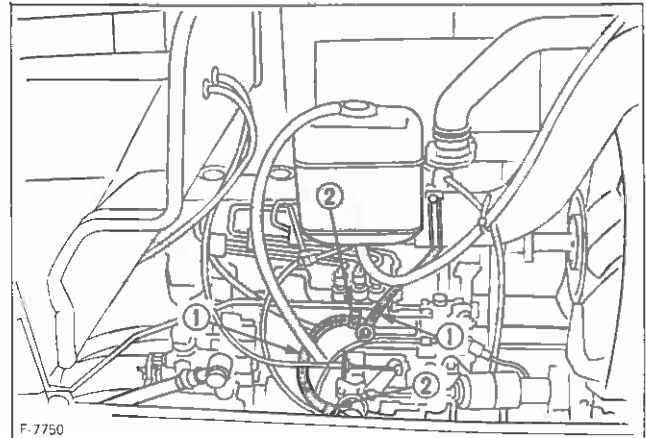

- ① Fuel lines
- ② Clamp bands

NOTE:

- If the fuel line is removed, be sure to properly bleed the fuel system. (See "Bleeding Fuel System" in as required maintenance)

■ Adjusting Toe-in

- (1) Park tractor on a flat place.
- (2) Turn steering wheel so front wheels are in the straight ahead position.
- (3) Lower the implement, lock the park brake and stop the engine.
- (4) Measure distance between tire beads at front of tire, hub height.
- (5) Measure distance between tire beads at rear of tire, hub height.
- (6) Front distance should be 2 to 8mm (0.1 to 0.3 in.) less than rear distance.
If not, adjust tie rod length.

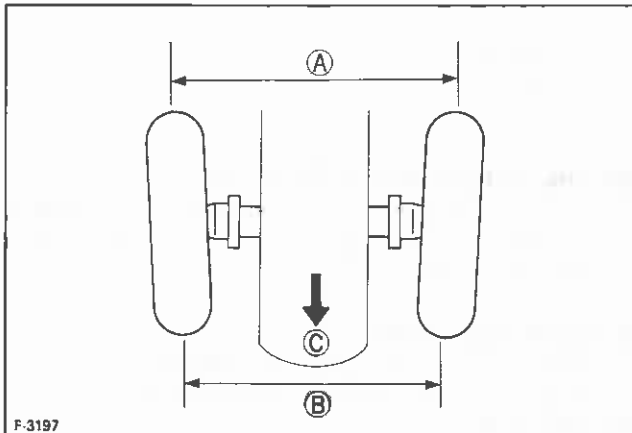

F-3197

- Ⓐ Wheel - to - wheel distance at rear
- Ⓑ Wheel - to - wheel distance at front
- Ⓒ "FRONT"

◆ Adjusting procedure

- (1) Loosen the lock nut and turn the turnbuckle to adjust the rod length until the proper toe-in measurement is obtained.
- (2) Retighten the lock nut.

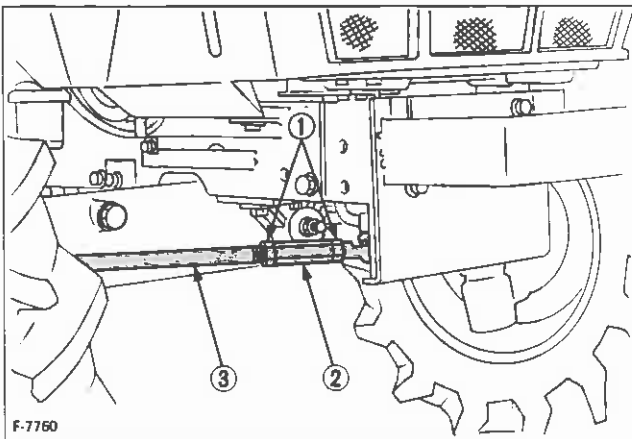

F-7760

- ① Lock nuts
- ② Turn buckle
- ③ Tie rod

EVERY 400 HOURS

■ Changing Transmission Fluid



CAUTION

To avoid personal injury:

- Allow engine to cool down sufficiently, oil can be hot and can burn.

- (1) To drain the used oil, remove the drain plug at the bottom of the transmission case and drain the oil completely into the oil pan.
- (2) After draining reinstall the drain plug.
- (3) Fill with the new KUBOTA SUPER UDT fluid up to the upper notch on the dipstick.
(See "LUBRICANTS" in Maintenance Section)
- (4) After running the engine for a few minutes, stop it and check the oil level again; add oil to prescribed level.

Oil capacity	39 ℓ (10.3 U.S.gals.)
--------------	-----------------------

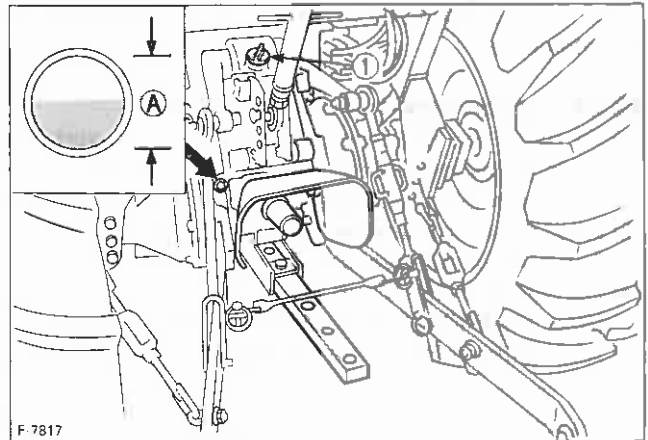

F-7817

- ① Oil inlet
- Ⓐ Oil level is acceptable within this range

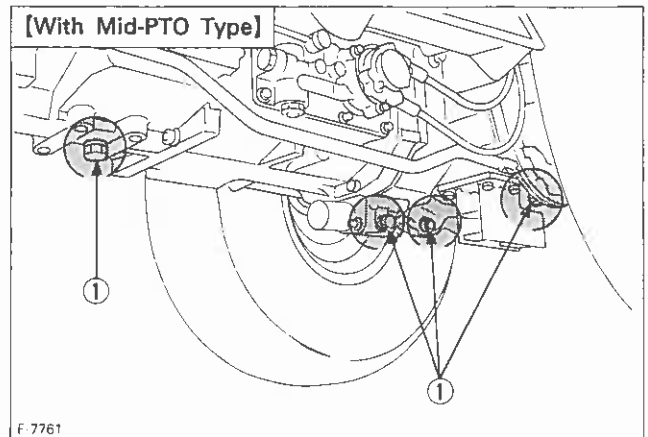

F-7761

- ① Drain plugs

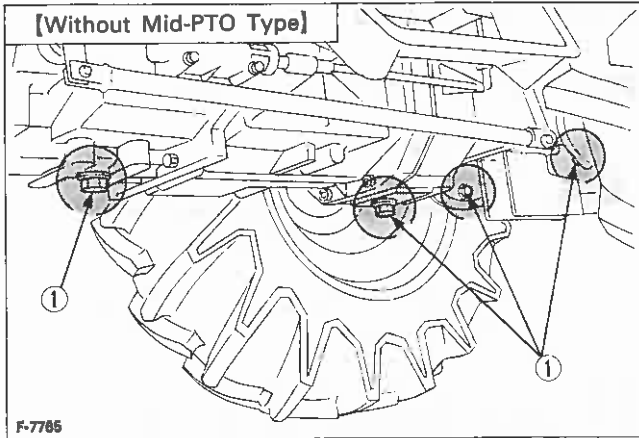

① Drain plugs

IMPORTANT:

- Do not operate the tractor immediately after changing the transmission fluid. Run the engine at medium speed for a few minutes to prevent damage to the transmission.

■ Replacing Fuel Filter Element

(See "Cleaning fuel filter" in every 100 hours maintenance.)

■ Changing Front Axle Case Oil

- (1) To drain the used oil, remove the right and left drain plugs and filling plugs at the front axle case and drain the oil completely into the oil pan.
- (2) After draining reinstall the drain plugs.
- (3) Remove the oil level check plug.
- (4) Fill with the new oil up to the check plug port. (See "LUBRICANTS" in Maintenance Section)
- (5) After filling reinstall the filling plug and check plug.

Oil capacity	5.5 ℓ (5.8 U.S.qts.)
--------------	----------------------

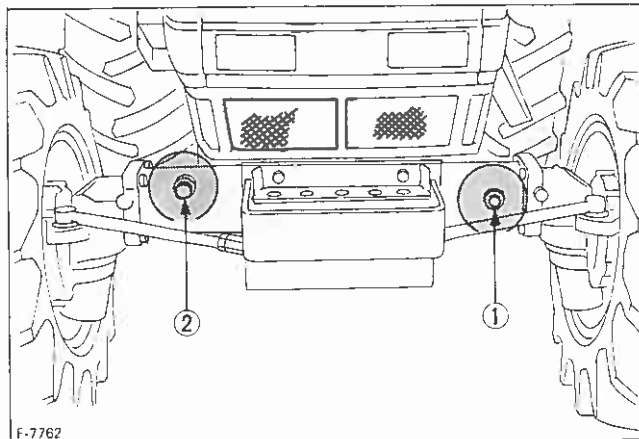

F-7762

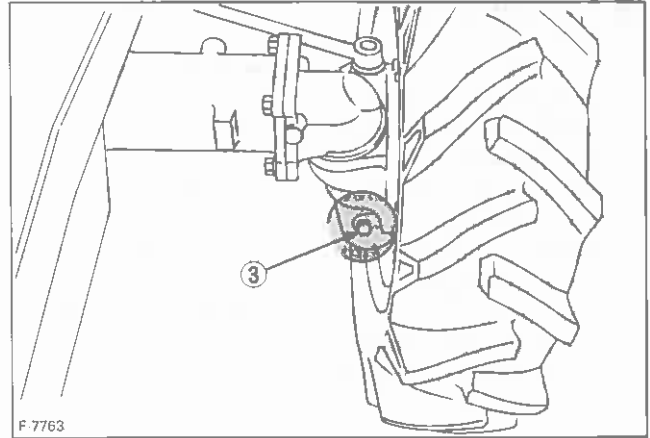

- ① Check plug
- ② Filling plug
- ③ Drain plug

■ Adjusting Front Axle Pivot

If the front axle pivot pin adjustment is not correct, front wheel vibration can occur causing vibration in the steering wheel.

◆ Adjusting procedure

Loosen the lock nut, tighten the adjusting screw all the way, and then loosen the screw by 1/6 turn. Retighten the lock nut.

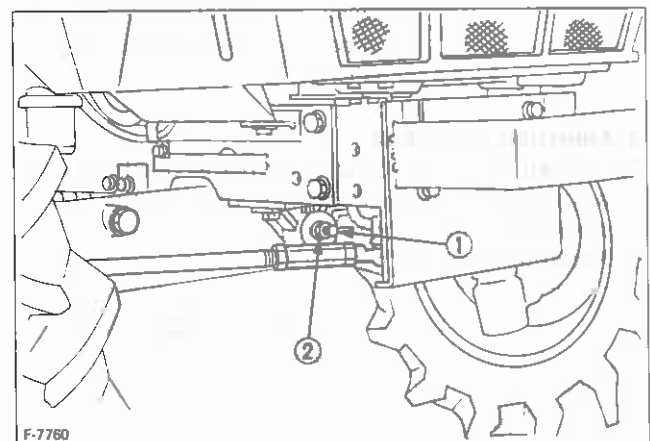

- ① Adjusting screw
- ② Lock nut

■ Lubricate Grease Fitting (2WD)

Detach the cover, and apply bearing grease.

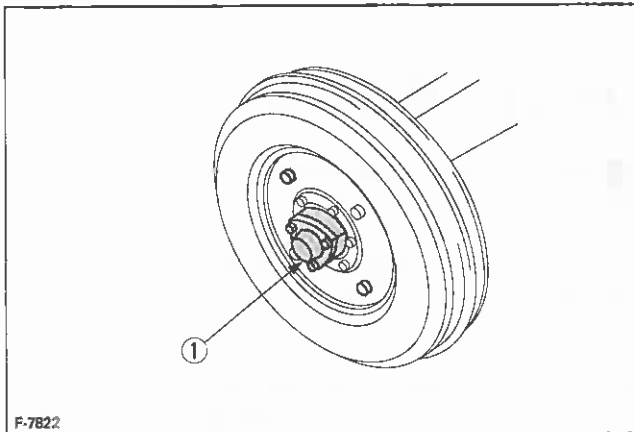

① Front wheel hub cover

EVERY 800 HOURS

■ Adjusting Engine Valve Clearance

Consult your local KUBOTA dealer for this service.

EVERY 1 YEAR

■ Replacing Air Cleaner Element

(See "Cleaning Air Cleaner Primary Element" in every 100 hours maintenance.)

EVERY 2 YEARS

■ Flush Cooling System and Changing Coolant



CAUTION

To avoid personal injury:

- Do not remove the radiator cap when the engine is hot. Then loosen cap slightly to the stop to relieve any excess pressure before removing cap completely.

- (1) Stop the engine and let cool down.
- (2) To drain the coolant, open the radiator drain plug. And remove radiator cap. The radiator cap must be removed to completely drain the coolant.
- (3) After all coolant is drained, close the drain plug.
- (4) Fill with clean water and cooling system cleaner.
- (5) Follow directions of the cleaner instruction.

- (6) After flushing, fill with clean water and anti-freeze until the coolant level is just below the port.

Install the radiator cap securely.

- (7) Fill with coolant up to the "FULL" mark of recovery tank.
- (8) Start and operate the engine for few minutes.
- (9) Stop the engine and let cool.
- (10) Check coolant level of recovery tank and add coolant if necessary.

Coolant capacity	L2900 · L3300	7.0 ℓ (7.4 U.S.qts.)
	L3600 · L4200	7.5 ℓ (7.9 U.S.qts.)

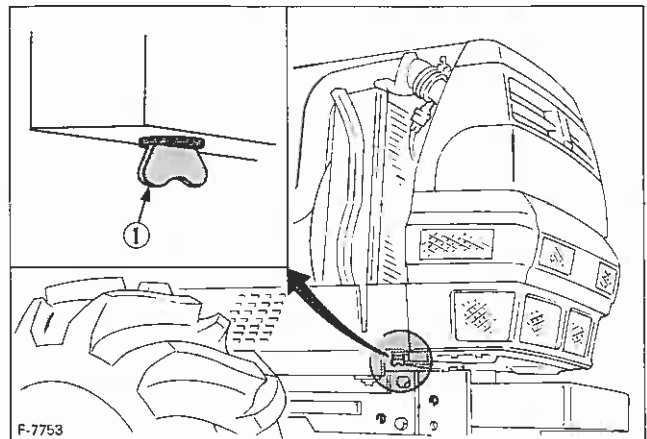

① Drain plug

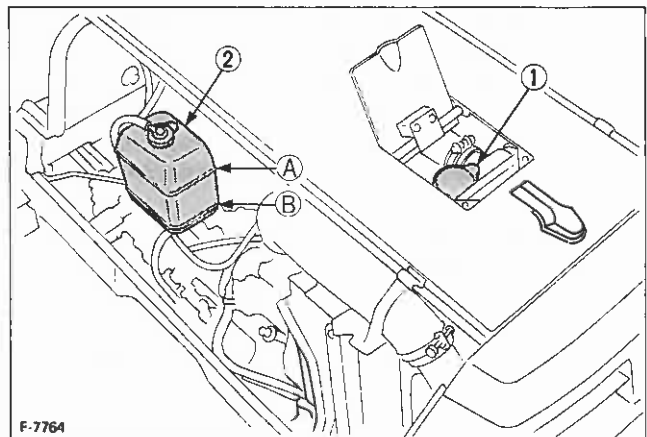

- ① Radiator cap
- ② Recovery tank
- A "FULL"
- B "LOW"

IMPORTANT:

- Do not start engine without coolant.
- Use clean, fresh water and anti-freeze to fill the radiator and recovery tank.
- When the anti-freeze is mixed with water, the anti-freeze mixing ratio must be less than 50%.
- Securely tighten radiator cap. If the cap is loose or improperly fitted, water may leak out and the engine could overheat.

■ Anti-Freeze

If it freezes, cooling water can damage the cylinders and radiator. It is necessary, if the ambient temperature falls below 0°C (32°F), to remove cooling water after operating or to add anti-freeze to it.

- (1) There are two types of anti-freeze available; use the permanent type (PT) for this engine.
- (2) Before adding anti-freeze for the first time, clean the radiator interior by pouring fresh water and draining it a few times.
- (3) The procedure for mixing of water and anti-freeze differs according to the make of the anti-freeze and the ambient temperature, basically it should be referred to SAE J1034 standard, more specifically also to SAE J814c.
- (4) Mix the anti-freeze with water, and then fill in to the radiator.

Vol % Anti-freeze	Freezing Point		Boiling Point*	
	°F	°C	°F	°C
40	-12	-24	222	106
50	-34	-37	226	108

* At 760mmHg pressure (atmospheric). A higher boiling point is obtained by using a radiator pressure cap which permits the development of pressure within the cooling system.

NOTE:

- The above data represents industry standards that necessitate a minimum glycol content in the concentrated anti-freeze.
- When the cooling water level drops due to evaporation, add water only. In case of leakage, add anti-freeze and water in the specified mixing ratio.
- Anti-freeze absorbs moisture. Keep unused anti-freeze in a tightly sealed container.
- Do not use radiator cleaning agents when anti-freeze has been added to the cooling water. (Anti-freeze contains an anti-corrosive agent, which will react with the radiator cleaning agent forming sludge which will affect the engine parts.)

■ Replacing Radiator Hose (Water pipes)

Replace the hoses and clamps.

(See "Checking Radiator Hose and Clamp" in every 200 hours maintenance.)

■ Replacing Power Steering Hose

Replace the hoses and clamps, if necessary.

(See "Checking Power Steering line" in every 200 hours maintenance.)

■ Replacing Fuel Hose

Replace the hoses and clamps, if necessary.

(See "Checking Fuel line" in every 200 hours maintenance.)

SERVICE AS REQUIRED

■ Bleeding Fuel System

Air must be removed:

- (1) When the fuel filter or lines are removed.
- (2) When tank is completely empty.
- (3) After the tractor has not been used for a long period of time.

◆ Bleeding procedure is as follows:

- (1) Fill the fuel tank with fuel, and open the fuel cock.

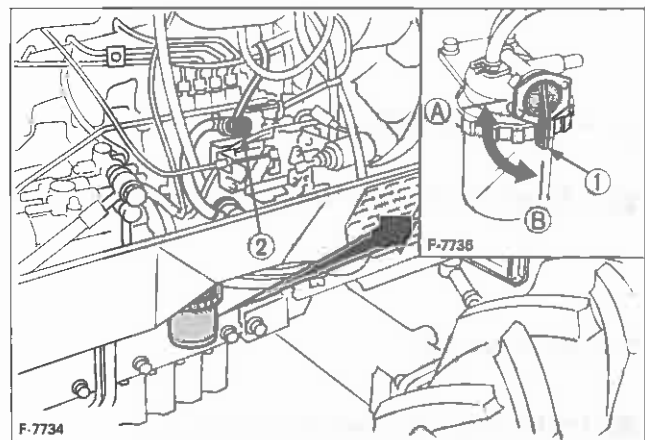

① Fuel cock

Ⓐ "CLOSE"

② Air vent cock

Ⓑ "OPEN"

- (2) Open the air vent cock on the fuel injection pump.
- (3) Start the engine and run for about 30 seconds, and then stop the engine.
- (4) Close the air vent cock.

IMPORTANT:

- Always close the air vent cock except for bleeding fuel lines. Otherwise, engine runs irregularly or stalls frequently.

■ Draining Clutch Housing Water

The tractor is equipped with split pin plug under the clutch housing.

After operating in rain, snow or tractor has been washed, water may get into the clutch housing. Check it by pushing in the split pin . If water enters into the clutch housing, remove the plug and drain the water, then install the plug again.

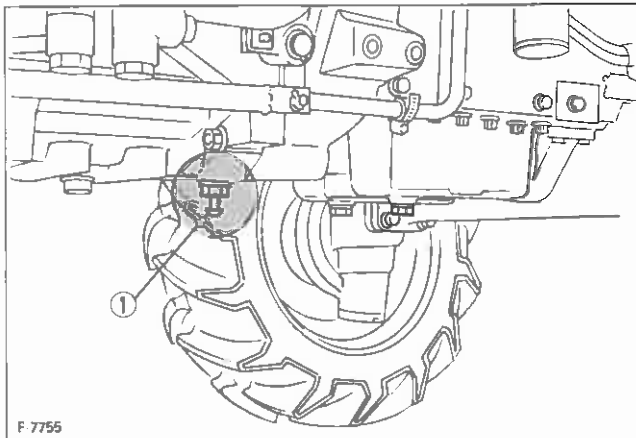

① Water drain plug

■ Replacing Fuse

The tractor electrical system is protected from potential damage by fuses.

A blown fuse indicates that there is an overload or short somewhere in the electrical system.

If any of the fuses should blow, replace with a new one of the same capacity,

IMPORTANT:

- Before replacing a blown fuse, determine why the fuse blew and make any necessary repairs. Failure to follow this procedure may result in serious damage to the tractor electrical system. Refer to the troubleshooting section of this manual or your local KUBOTA dealer for specific information dealing with electrical problems.
- If any of them should blow, replace with a new one of the same capacity.

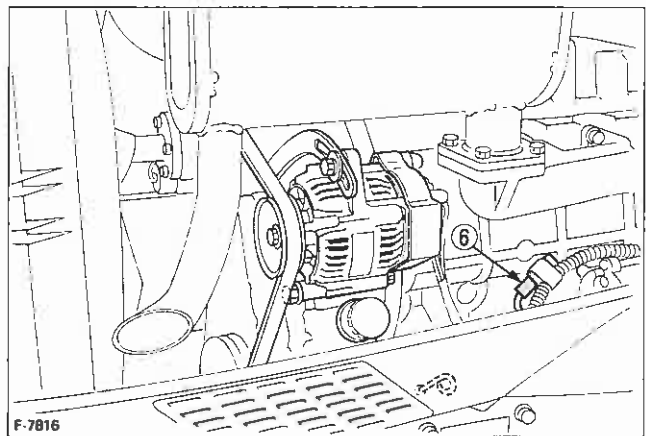
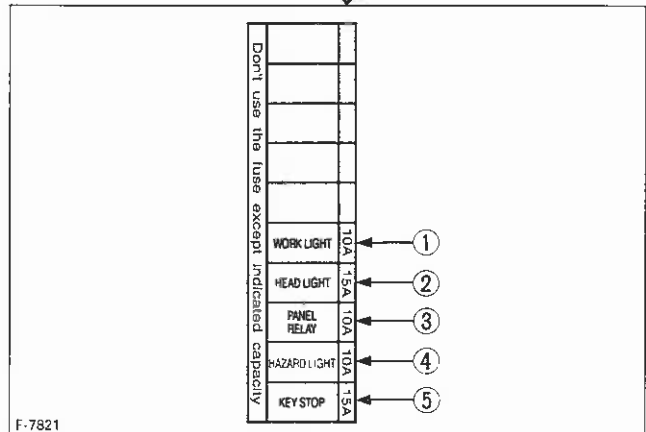
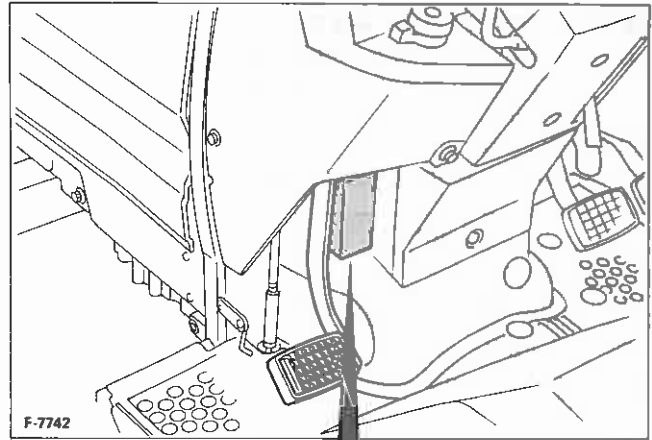

◆ Protected circuit

Fuse No.	Capacity (A)	Protected circuit
①	10	Work light
②	15	Head light
③	10	Panel, Relay
④	10	Hazard light
⑤	15	Key stop
⑥	Slow blow fuse	Check circuit against wrong battery connection.

■ Replacing Light Bulb**(1) Head lights and rear combination lights**

Take the bulb out of the light body and replace with a new one.

(2) Other lights

Detach the lens and replace the bulb.

Light	Capacity
Headlights	25W/25W
Tail light, Parking light (rear)	8W
Hazard light	27W
Instrument panel light	3.4W

STORAGE



CAUTION

To avoid personal injury:

- Do not clean the machine with engine running.
- To avoid the danger of exhaust fume poisoning, do not operate the engine in a closed building without proper ventilation.
- When storing, remove the key from the key switch to avoid unauthorized persons from operating the tractor and getting injured.

TRACTOR STORAGE

If you intend to store your tractor for an extended period of time, follow the procedures outlined below. These procedures will insure that the tractor is ready to operate with minimum preparation when it is removed from storage,

- (1) Check the bolts and nuts for looseness, and tighten if necessary.
- (2) Apply grease to tractor areas where bare metal will rust also to pivot areas.
- (3) Detach the weights from the tractor body.
- (4) Inflate the tires to a pressure a little higher than usual.
- (5) Change the engine oil and run the engine to circulate oil throughout the engine block and internal moving parts for about five minutes.
- (6) Pull the engine stop knob all the way out.
- (7) Keep the clutch disengaged. If the clutch is left engaged for a long period of time, the clutch plate may rust, making clutch disengagement impossible at the next operation.

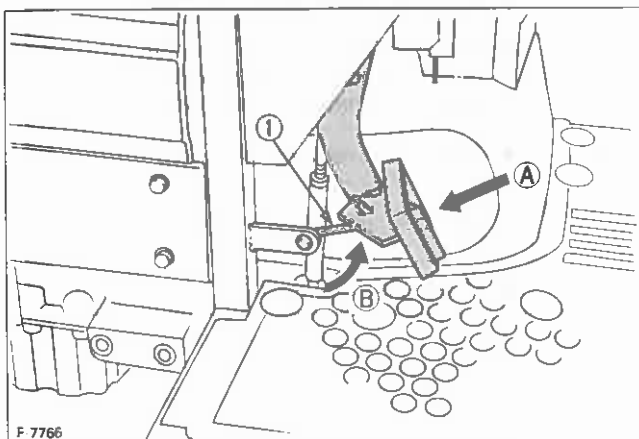

① Lock plate

Ⓐ "DEPRESS"

Ⓑ "HOOK TO LOCK"

- (8) With all implements lowered to the ground, coat any exposed hydraulic cylinder piston rods with grease.
- (9) Remove the battery from the tractor. Store the battery following the battery storage procedures. (See "Battery condition" in every 100 hours in periodic service section.)
- (10) Keep the tractor in a dry place where the tractor is sheltered from rain. Cover the tractor.
- (11) Store the tractor indoors in a dry area that is protected from sunlight and excessive heat. If the tractor must be stored outdoors, cover it with a waterproof tarpaulin.
Jack the tractor up and place blocks under the front and rear axles so that all four tires are off the ground. Keep the tires out of direct sunlight and extreme heat.

IMPORTANT:

- When washing the tractor, be sure to stop the engine. Allow sufficient time for the engine to cool before washing.
- Cover the tractor after the muffler and the engine have cooled down.

REMOVING THE TRACTOR FROM STORAGE

- (1) Check the tire air pressure and inflate the tires if they are low.
- (2) Jack the tractor up and remove the support blocks from under the front and rear axles.
- (3) Install the battery. Before installing the battery, be sure it is fully charged.
- (4) Check the fan belt tension.
- (5) Check all fluid levels (engine oil, transmission/hydraulic oil, engine coolant and any attached implements).
- (6) Start the engine. Observe all gauges. If all gauges are functioning properly and reading normal, move the tractor outside. Once outside, park the tractor and let the engine idle for at least five minutes. Shut the engine off and walk around tractor and make a visual inspection looking for evidence of oil or water leaks.
- (7) With the engine fully warmed up, release the parking brake and test the brakes for proper adjustment as you move forward. Adjust the brakes as necessary.

TROUBLESHOOTING

ENGINE TROUBLESHOOTING

If something is wrong with the engine, refer to the table below for the cause and its corrective measure.

Trouble		Cause	Countermeasure
Engine is difficult to start or won't start.		<ul style="list-style-type: none"> No fuel flow. 	<ul style="list-style-type: none"> Check the fuel tank and the fuel filter. Replace filter if necessary.
		<ul style="list-style-type: none"> Air or water is in the fuel system. 	<ul style="list-style-type: none"> Check to see if the fuel line coupler bolt and nut are tight. Bleed the fuel system (See "Bleeding Fuel system" in as required maintenance)
		<ul style="list-style-type: none"> In winter, oil viscosity increases, and engine revolution is slow. 	<ul style="list-style-type: none"> Use oils of different viscosities, depending on ambient temperatures. Use engine block heater. (Option)
		<ul style="list-style-type: none"> Battery becomes weak and the engine does not turn over quick enough. 	<ul style="list-style-type: none"> Clean battery cables and terminals. Charge the battery. In cold weather, always remove the battery from the engine, charge and store it indoors. Install it on the tractor only when the tractor is going to be used.
Insufficient engine power.		<ul style="list-style-type: none"> Insufficient of dirty fuel. The air cleaner is clogged. 	<ul style="list-style-type: none"> Check the fuel system. Clean the element.
Engine stops suddenly.		<ul style="list-style-type: none"> Insufficient fuel. 	<ul style="list-style-type: none"> Refuel. Bleed the fuel system if necessary.
Exhaust fumes are colored.	Black	<ul style="list-style-type: none"> Fuel quality is poor. Too much oil. 	<ul style="list-style-type: none"> Change the fuel and fuel filter. Check the proper amount of oil.
	Blue white	<ul style="list-style-type: none"> The inside of exhaust muffler is dumped with fuel. Injection nozzle trouble. Poor quality fuel. 	<ul style="list-style-type: none"> Heat the muffler by applying load to the engine. Check the injection nozzle. Change the fuel and fuel filter.
Engine overheats.		<ul style="list-style-type: none"> Engine overloaded. 	<ul style="list-style-type: none"> Shift to lower gear or reduce load.
		<ul style="list-style-type: none"> Low coolant level. 	<ul style="list-style-type: none"> Fill cooling system to the correct level; check radiator and hoses for loose connections or leaks.
		<ul style="list-style-type: none"> Loose or defective fan belt. 	<ul style="list-style-type: none"> Adjust or replace fan belt.
		<ul style="list-style-type: none"> Dirty radiator core or grille screens. 	<ul style="list-style-type: none"> Remove all trash.
		<ul style="list-style-type: none"> Coolant flow route corroded. 	<ul style="list-style-type: none"> Flush cooling system.

If you have any questions, contact your local KUBOTA dealer.

OPTIONS

Consult your local KUBOTA dealer for further detail.

- Engine Block Heater
For extremely cold weather starting.
- Under Muffler
For low profile.
- Double Element Air Cleaner
For extremely dusty conditions.
- SMV (Slow Moving Vehicle) Emblem:
To identify slow moving vehicle.
- Work Light
High visibility for night work.
- Creep gear
- Double Acting Remote Hydraulic Control Valve
- Draft Control
- Drawbar
- Swinging Drawbar
- Clevis Type Swinging Drawbar
- Front end weights.
For front ballast.
- Rear Wheel Weights.
For rear ballast.
- Front wheel weights.
- Sunshade
- Top & tilt kit (For scraper)

KUBOTA

- U.S.A. : KUBOTA TRACTOR CORPORATION**
3401 Del Amo Blvd. Torrance CA 90503 U.S.A.
Telephone : (310)370-3370
- Western Division : 6665 E. Hardaway Rd., Stockton, CA 95215**
Telephone : (209)931-5051
- Central Division : 13780 Benchmark Drive Farmers Branch, TX 75234**
Telephone : (214)241-5900
- Northern Division : 438 McCormick Blvd., Columbus, OH 43213**
Telephone : (614)868-1278
- Southeast Division : 1025 NorthBrook Parkway, Suwanee, GA 30174**
Telephone : (404)995-8855
- Engine Division : 1300 Remington Road, Suite K Schaumburg, IL 60173**
Telephone : (708)884-0212
- Canada : KUBOTA CANADA LTD.**
1495 Denison Street, Markham, Ontario, L3R 5H1, Canada
Telephone : (416)475-1090
- Richmond Distribution Center : 2620 Viscount Way, Richmond, B.C. V6V 1N1**
Telephone : (604)270-9286
- Drummondville Distribution Center : 5705 Place Kubota, Grantham Ouest (Drummondville),
Quebec, J2B 6V4 Telephone : (819)478-7151**
- France : S.A. KUBOTA EUROPE**
19-25, rue Jules Verrocruyse BP88-Z.I., 95101
Argenteuil Cedex, France
- Germany : KUBOTA (DEUTSCHLAND) GmbH**
Senefelder Str. 3-5 63110 Rodgau / Nieder-Roden, Germany
- U.K. : KUBOTA (U.K.) LTD.**
Dormer Road, Thame, Oxfordshire, OX9 3UN, U.K.
- Australia : KUBOTA TRACTOR (AUSTRALIA) PTY., LTD.**
9-23 King William Street, Broadmeadows, Victoria 3047 Australia
- Malaysia : KUBOTA AGRICULTURAL MACHINERY SDN. BHD.**
Lot 14A, Jalan Perusahaan 4, Batu Caves Industrial
Estate, 68100 Batu Caves, Selangor, Malaysia
- Philippines : KUBOTA AGRI-MACHINERY PHILIPPINES, INC.**
1031 Epifanio De Los Santos Ave. (EDSA)
Quezon City, Metro-Manila, Philippines
- Taiwan : SHIN TAIWAN AGRICULTURAL MACHINERY CO., LTD.**
16, Fengping 2nd Road, Taliiao Shiang Kaohsiung Hsien, 83107, Taiwan R.O.C
- Brazil : KUBOTA BRASIL LTDA.**
AV. Fagundes De Oliveira 900, Piraporinha-Diadema, São Paulo, Brazil
- Iran : IRAN KUBOTA INDUSTRIAL WORKS, LTD.**
Mobarezan Ave., No.82, Alimoseo St., Teheran, Iran
- Indonesia : P.T. KUBOTA INDONESIA**
JL. Setyabudi 279, Semarang, Indonesia
- Thailand : THE SIAM KUBOTA INDUSTRY CO., LTD.**
1 Siam Cement Road, Bangsue, Bangkok 10800, Thailand
- Egypt : KUBOTA Corporation CAIRO LIAISON OFFICE**
12th Floor, Nile Tower Bldg
21-23 Guiza Street, Guiza, Egypt
- Japan : KUBOTA Corporation**
Farm & Industrial Machinery International Operations Headquarters
2-47, Shikitsuhashi 1-chome, Naniwa-ku, Osaka 556 Japan

英語 (U.S.A)

Code No. TA040-1971-1