

B122P015

### Commutator Ring

1. Remove the commutator ring (1).

(1) Commutator Ring

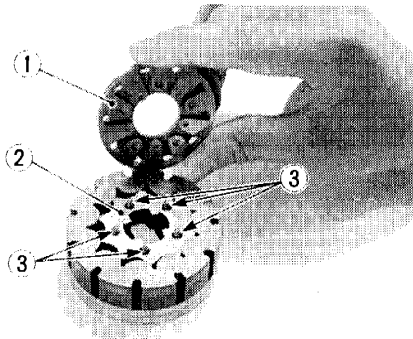

B122P016

### Commutator and Alignment Pins

1. Remove the commutator (1) from the rotor (2).
2. Pull out the five alignment pins (3).

#### **(When reassembling)**

- Make sure the five alignment pins (3) are pressed below the surface of the commutator (1).
- Place a few drops of oil into each recess in the commutator (1).

(1) Commutator  
(2) Rotor

(3) Alignment Pins

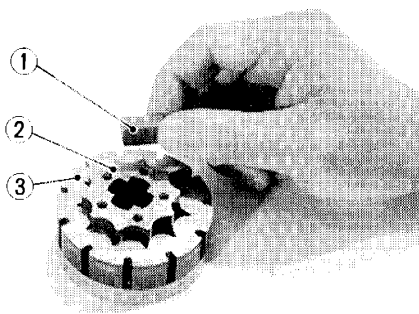

B122P017

### Drive Link Spacer and Rotor Set

1. Remove the drive link spacer (1).
2. Remove the rotor (2) and the stator (3) as a unit.

#### **(When reassembling)**

- Apply small amount of clean grease to drive link spacer (1) and insert it into the drive slot in the rotor (2).

#### **■ IMPORTANT**

- Handle the rotor set carefully to avoid nicks and scratches.

(1) Drive Link Spacer  
(2) Rotor

(3) Stator

## SERVICING

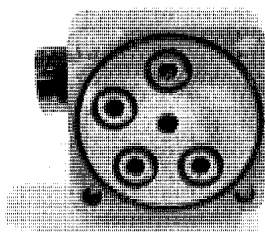

B122P018

### Port Cover

1. Inspect the port cover for port fitting sealing surface scratches and thread damage.
2. If these conditions, replace the port cover assembly.

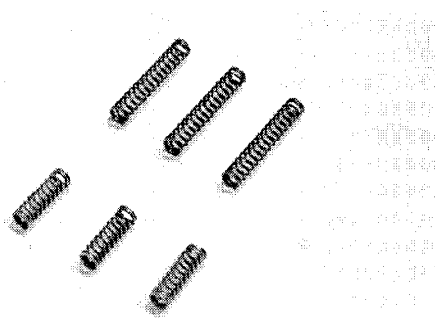

B122P019

### Springs

1. Inspect the springs for bent or distorted coils.
2. If a spring is broken or deformed, all six springs in the unit should be replaced.

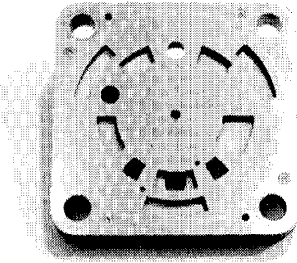

B122P020

### Port Manifold

1. Inspect the ground surface of the port manifold.
2. If the port manifold shows nicks or scoring or the edges are not sharp, replace the steering controller assembly.

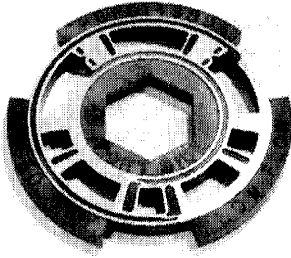

B122P021

### Valve Plate

1. Inspect the slot edges and ground surface.
2. If the valve plate shows nicks or scoring or the edges are not sharp, replace the steering controller assembly.

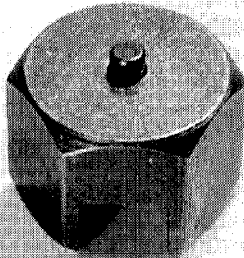

B122P022

### Hex. Drive Assembly

1. The pin in the hex. drive assembly should not show wear and must be firmly pressed in place.
2. The sides of the hex. and the slot should not have grooves or scoring.
3. If the hex. drive assembly shows signs of this type of wear, replace the steering controller assembly.

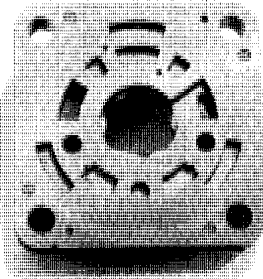

B122P023

### Isolation Manifold

1. Inspect the ground surface of the isolation manifold.
2. If the isolation manifold shows nicks or scoring or the edges are not sharp, replace the steering controller assembly.

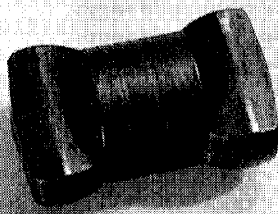

B122P024

### Drive Link

1. Inspect each end of the drive link.
2. If the drive link shows wear or scoring, replace the steering controller assembly.

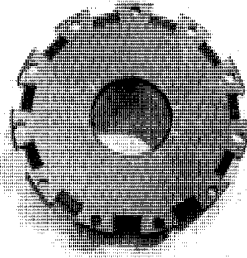

B122P025

**Commutator Cover**

1. Inspect the ground surfaces of the commutator cover.
2. If the commutator cover has nicks, burrs or scoring, replace the steering controller assembly.

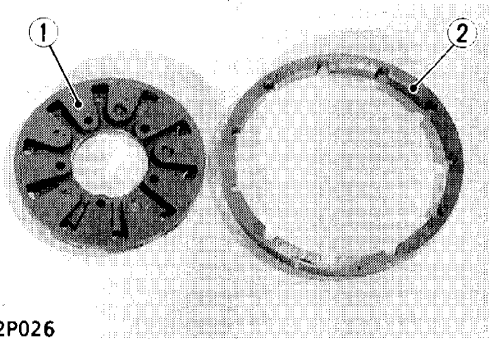

**Commutator Ring and Commutator**

1. Inspect the ground surfaces of the commutator (1) and inside surfaces of the commutator ring (2).
2. If either is worn or damaged, replace the steering controller assembly.

(1) Commutator

(2) Commutator Ring

B122P026

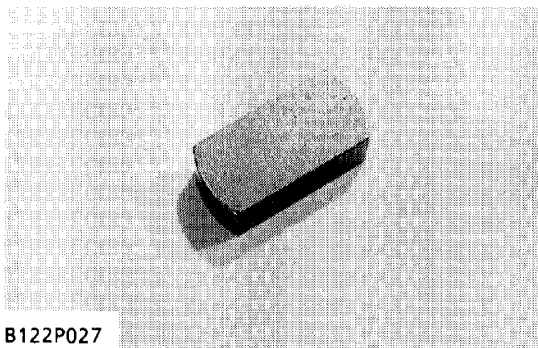

**Drive Link Spacer**

1. Inspect the drive link spacer.
2. If the drive link spacer is grooved or worn, replace the steering controller assembly.

B122P027

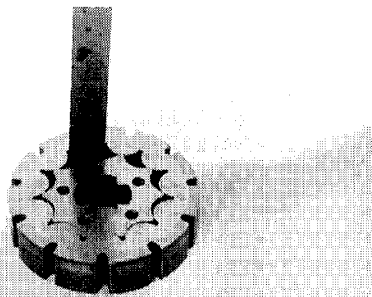

**Rotor Set**

1. Measure the rotor lobe tip to stator lobe tip clearance, using the appropriate feller gauge.
2. If the clearance exceeds the allowable limit, replace the steering controller assembly.

Clearance between rotor lobe tip and stator lobe tip	Allowable limit	0.08 mm 0.0031 in.
--	-----------------	-----------------------

B122P028

Input Shaft Side

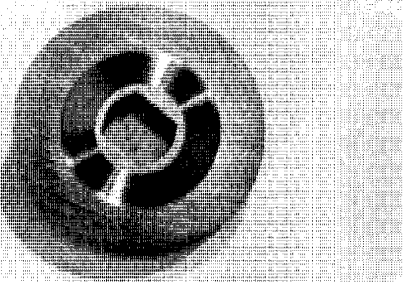

B122P029

Rotor Side

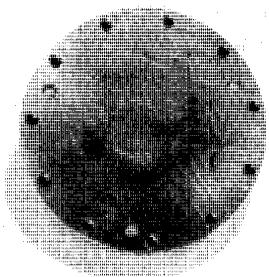

B122P030

**Drive Plate**

1. The rotor side of the drive plate should show the "normal" spiral pattern due to rotor movement.
2. Inspect the thrust bearing side of the plate for brinelling (dents) or spalling (flaking).
3. The flat sides of the input shaft engagement hole should not be grooved or worn.
4. If any of these conditions are present, replace the steering controller assembly.

**Bearing and Spacers**

1. Inspect the thrust bearing for brinelling (dents) or spalling (flaking).
2. If either exists, or if one or more of the rolls are lost or broken, replace the steering controller assembly.
3. If the seal spacer or bearing spacer are worn or broken, replace the steering controller assembly.

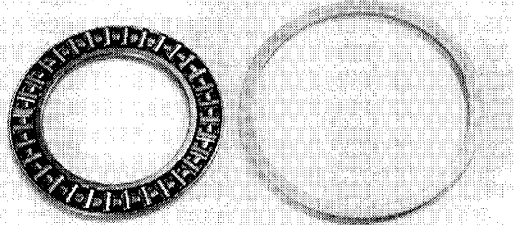

B122P031

**[4] STEERING CYLINDER AND PITMAN ARM**

**CHECKING**

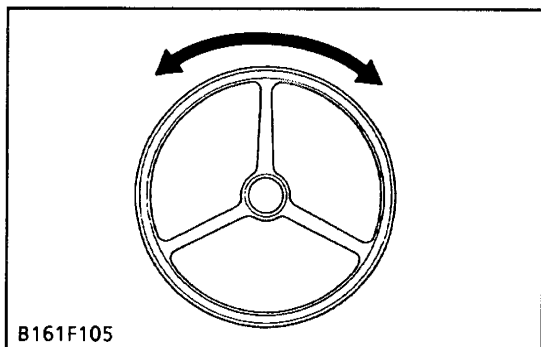

B161F105

**Steering Wheel Free Play**

1. Start the engine, and set the engine speed at idling.
2. Rotate the steering wheel lightly by hand, and measure the play.
3. If the play is not within factory specifications, check the steering linkage.

Steering wheel free play	Factory spec.	20 to 50 mm 0.79 to 1.97 in.
--------------------------	---------------	---------------------------------

## DISASSEMBLING AND ASSEMBLING

### (1) Removing Steering Cylinder and Pitman Arm

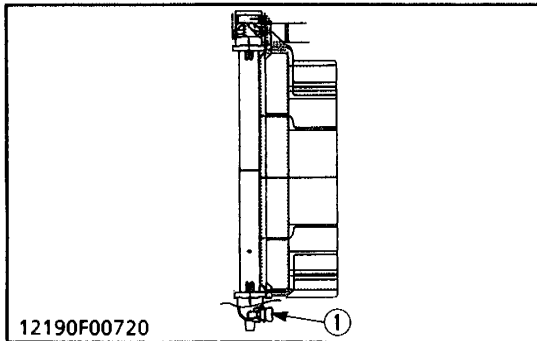
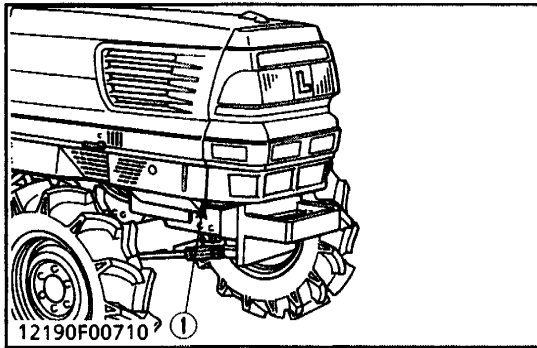

(1) Drain Plug

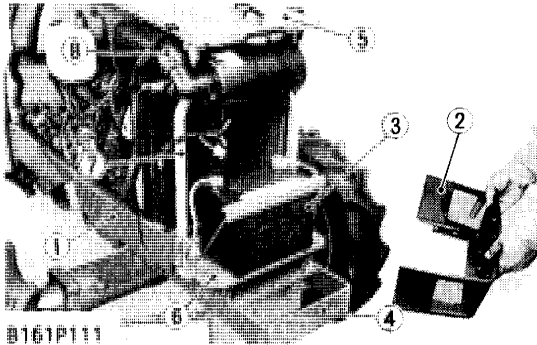

#### Draining Coolant

#### ⚠ CAUTION

- Never remove the radiator cap until coolant temperature is well below its boiling point. Then loosen cap slightly to the stop to relieve any excess pressure before removing cap completely.

1. Stop the engine and let cool down.
2. Loosen the drain plug (1) to drain the coolant.
3. Remove the radiator cap to completely drain the coolant.
4. After all coolant is drained, retighten the drain plug (1).

Coolant	Capacity	With ROPS	L3010 L3410	7.0 ℓ 7.4 U.S.qts. 6.2 Imp.qts.
			L3710 L4310	7.5 ℓ 7.9 U.S.qts. 6.6 Imp.qts.
		With CAB	L3710 L4310	8.7 ℓ 9.2 U.S.qts. 7.7 Imp.qts.

#### Preparation

1. Remove the front mask and side cover both sides.
2. Remove the front grille (2) and side skirt (1) both sides.
3. Remove the battery (3).
4. Remove the bumper (4).
5. Disconnect the air cleaner rubber hose (8) from the inlet manifold.
6. Remove the bonnet (5), plate (6) and bonnet support (7).

- |                  |                             |
|------------------|-----------------------------|
| (1) Side Skirt   | (5) Bonnet                  |
| (2) Front Grille | (6) Plate                   |
| (3) Battery      | (7) Bonnet Support          |
| (4) Bumper       | (8) Air Cleaner Rubber Hose |

#### Radiator

1. Disconnect the three radiator hoses from the radiator (1).
2. Remove the snap pins, and then loosen the radiator mounting screws. (L3710 · L4310)
3. Take out the radiator (1).

- (1) Radiator

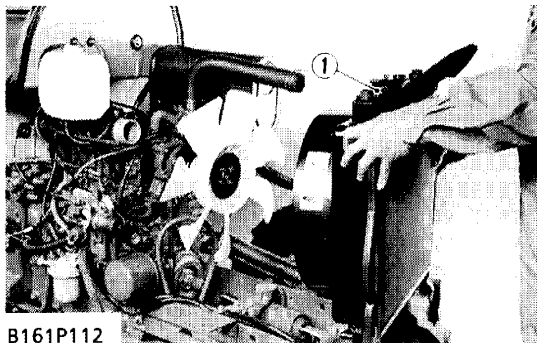

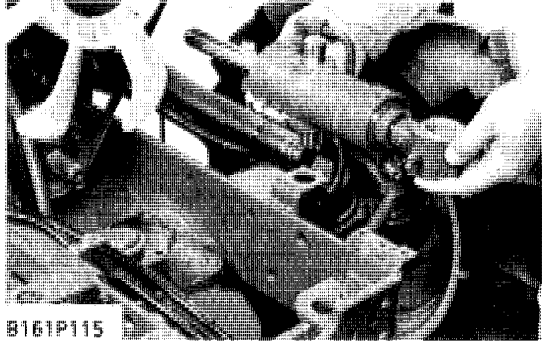
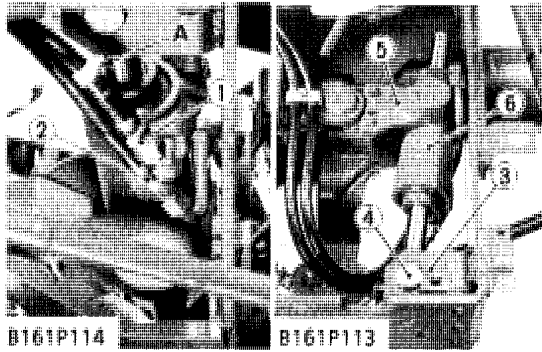

**Removing Steering Cylinder**

1. Disconnect the turning delivery hoses (1) and (2).
2. Remove the rod end shaft stopper (3), and then push out the rod end shaft (4).
3. Remove the pitman arm cap (5).
4. Take out the steering cylinder (6).

**(When reassembling)**

- Apply grease to bushings.
- In assembling the turning delivery hoses (1) and (2) to the steering cylinder (6), connect the delivery hose with the identification mark "A" (tape) to the port (port of ①) in front of the steering cylinder (6).

Tightening torque	Rod end shaft stopper mounting screw	48.1 to 55.9 N·m 4.9 to 5.7 kgf·m 35.5 to 41.2 ft-lbs
	Pitman arm cap mounting reamer screws	48.1 to 55.9 N·m 4.9 to 5.7 kgf·m 35.5 to 41.2 ft-lbs
	Turning delivery hose retaining nut	24.5 to 29.4 N·m 2.5 to 3.0 kgf·m 18.1 to 21.7 ft-lbs

**[A] Identification Mark (Tape)**

- |                                 |                       |
|---------------------------------|-----------------------|
| (1) Right Turning Delivery Hose | (4) Rod End Shaft     |
| (2) Left Turning Delivery Hose  | (5) Pitman Arm Cap    |
| (3) Rod End Shaft Stopper       | (6) Steering Cylinder |

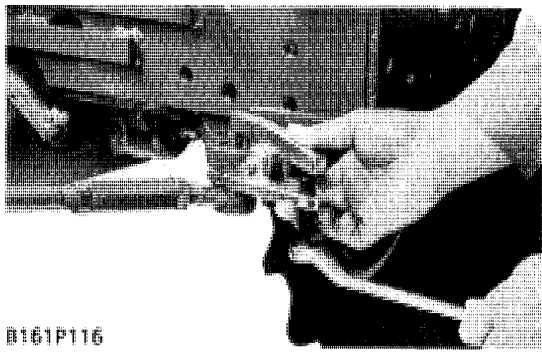

**Tie-rods**

1. Remove the tie-rods with the tie-rod end lifter.  
In this case, take special care not to damage the tie-rod end nut (slotted nut). (It is preferable to replace it with an unrequired nut.)

**(When reassembling)**

Tightening torque	Tie-rod end nut	2WD	49.0 to 68.6 N·m 5.0 to 7.0 kgf·m 36.2 to 50.6 ft-lbs
		4WD	39.2 to 45.1 N·m 4.0 to 4.6 kgf·m 28.9 to 33.3 ft-lbs

**■ IMPORTANT**

- After tightening the tie-rod end nut to the specified torque, install a cotter pin as shown in the figure left.

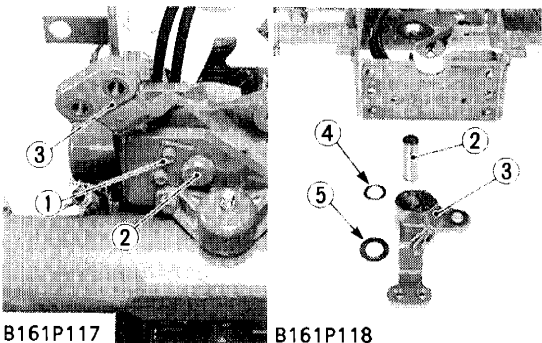
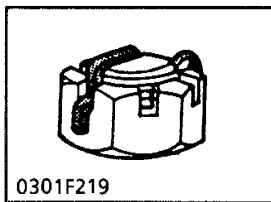

**Removing Pitman Arm**

1. Remove the pitman arm shaft stopper (1).
2. Push out the pitman arm shaft (2), and then take out the pitman arm (3).

**(When reassembling)**

- Apply grease to bushings and dust seals.

Tightening torque	Pitman arm shaft stopper mounting screw	48.1 to 55.9 N·m 4.9 to 5.7 kgf·m 35.5 to 41.2 ft-lbs
-------------------	---	---

- |                              |                    |
|------------------------------|--------------------|
| (1) Pitman Arm Shaft Stopper | (4) Washer (Upper) |
| (2) Pitman Arm Shaft         | (5) Washer (Lower) |
| (3) Pitman Arm               |                    |

## (2) Disassembling Steering Cylinder

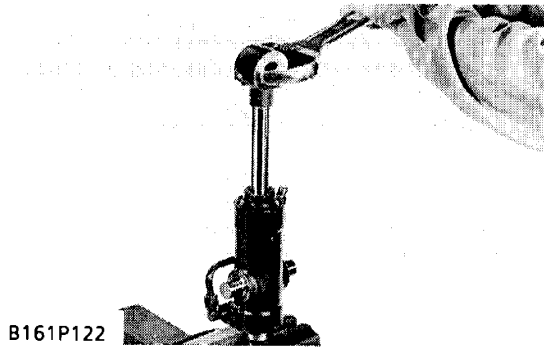

### Rod End

1. Secure the rod assembly with a vise.
2. Remove the rod end stopper screws.
3. Remove the rod end.

### (When reassembling)

- Apply liquid lock (Three Bond 1372 or equivalent) to the rod end screw and rod end stopper screws.

Tightening torque	Rod end	196 to 294 N·m 20 to 30 kgf·m 145 to 217 ft·lbs
	Rod end stopper screws	12.3 to 14.2 N·m 1.25 to 1.45 kgf·m 9.0 to 10.5 ft·lbs

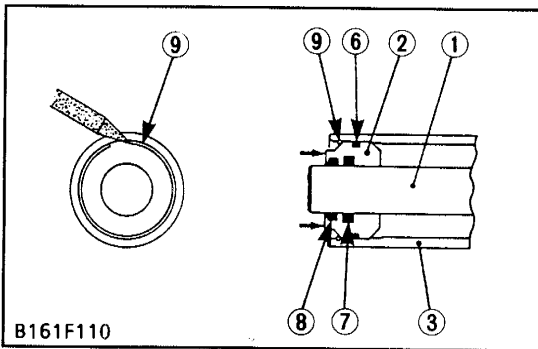

### Cylinder Cover Assembly and Rod Assembly

1. Tap in the cylinder cover assembly (2) lightly to inside of cylinder.
2. Use a pointed tool and remove the internal snap ring (9) by raising it out of the groove of the cylinder tube (3).
3. Tap the rod assembly (1) lightly to remove the cylinder cover assembly (2) from the cylinder tube (3).
4. Pull out the cylinder cover assembly (2) from the rod assembly (1).

### (When reassembling)

- Apply clean transmission fluid to the O-ring (5) and piston gasket (4).
- Do not spin the rod assembly (1) while inserting.
- Apply grease to the rod gasket (7), dust seal (8) and O-ring (6).

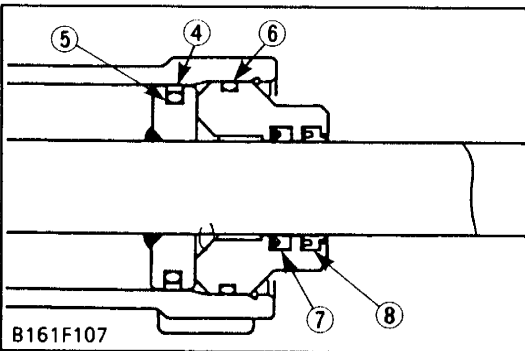
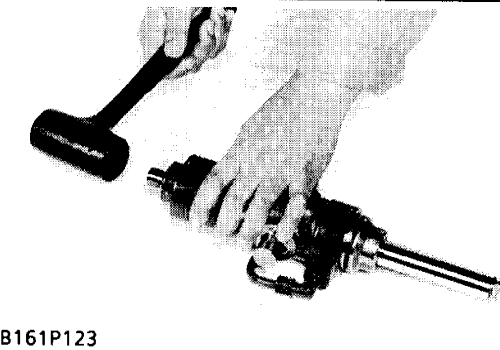

B161P123

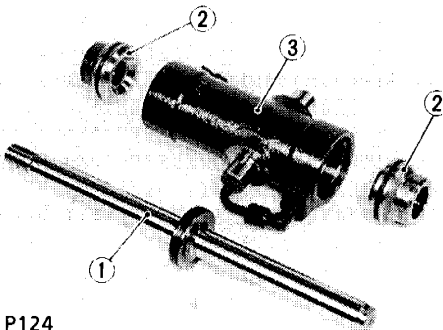

B161P124

- |                             |                        |
|-----------------------------|------------------------|
| (1) Rod Assembly            | (5) O-ring             |
| (2) Cylinder Cover Assembly | (6) O-ring             |
| (3) Cylinder Tube           | (7) Rod Gasket         |
| (4) Piston Gasket           | (8) Dust Seal          |
|                             | (9) Internal Snap Ring |

**SERVICING**

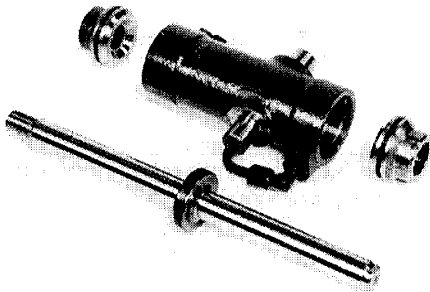

B161P124

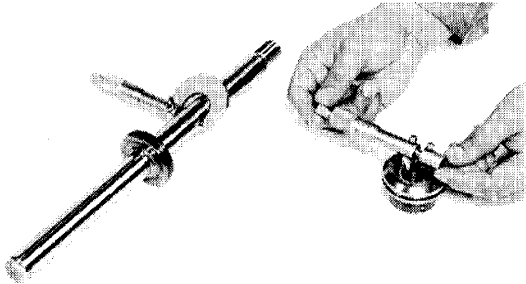

B161P125

**Cylinder Tube, Rod Assembly and Cylinder Covers**

1. Inspect the sliding surface of the cylinder tube, rod assembly and cylinder covers.
2. If they shows nicks or scoring, they must be replaced.

**Clearance between Rod and Cylinder Cover Bushing**

1. Measure the rod O.D. with an outside micrometer.
2. Measure the cylinder cover bushing I.D. with an inside micrometer, and calculate the clearance.
3. If the clearance exceeds the allowable limit, replace the cylinder cover bushing.

Clearance between rod and cylinder cover bushing	Factory spec.	0.020 to 0.134 mm 0.00079 to 0.00528 in.
	Allowable limit	0.145 mm 0.00571 in.

Rod O.D.	Factory spec.	24.947 to 24.980 mm 0.98216 to 0.98346 in.
Cylinder cover bushing I.D.	Factory spec.	25.000 to 25.081 mm 0.98425 to 0.98744 in.

**Cylinder Tube Wear**

1. Measure the cylinder tube I.D. with a cylinder gauge.
2. If the measurement exceeds the allowable limit, replace the cylinder tube.

Cylinder tube I.D.	Factory spec.	55.000 to 55.074 mm 2.16535 to 2.16826 in.
	Allowable limit	55.100 mm 2.16929 in.

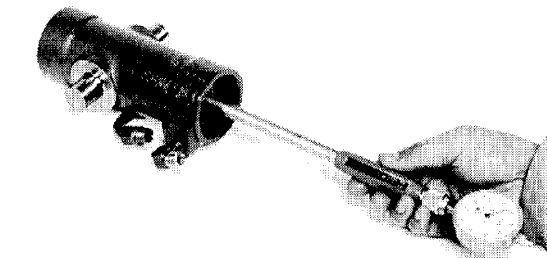

B161P126

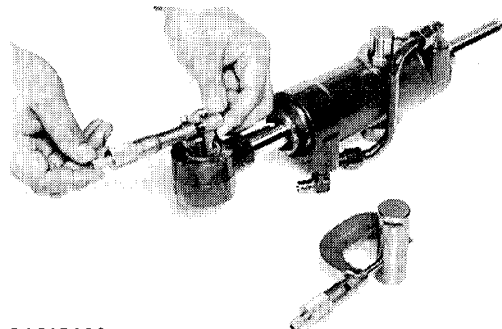

B161P128

**Clearance between Rod End Shaft and Rod End Bushing**

1. Measure the rod end shaft O.D. with an outside micrometer.
2. Measure the rod end bushing I.D. with an inside micrometer, and calculate the clearance.
3. If the clearance exceeds the allowable limit, replace the rod end bushing.

Clearance between rod end shaft and rod end bushing	Factory spec.	0.025 to 0.135 mm 0.00098 to 0.00531 in.
	Allowable limit	0.35 mm 0.0138 in.

Rod end shaft O.D.	Factory spec.	27.950 to 27.975 mm 1.10039 to 1.10138 in.
Rod end bushing I.D.	Factory spec.	28.000 to 28.085 mm 1.10236 to 1.10571 in.



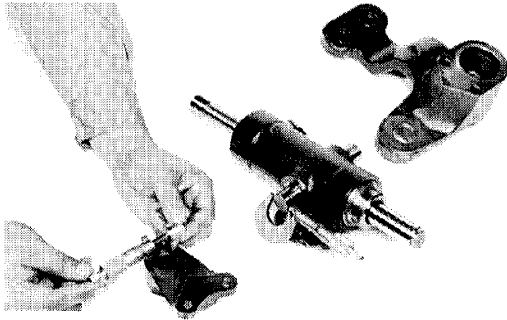

B161P127

**Clearance between Cylinder Tube Pin and Pitman Arm Bushing**

1. Measure the cylinder tube pin O.D. with an outside micrometer.
2. Measure the pitman arm bushing I.D. with an inside micrometer, and calculate the clearance.
3. If the clearance exceeds the allowable limit, replace the pitman arm bushing.

Clearance between cylinder tube pin and pitman arm bushing	Factory spec.	0.020 to 0.122 mm 0.00079 to 0.00480 in.
	Allowable limit	0.35 mm 0.0138 in.
Cylinder tube pin O.D.	Factory spec.	23.959 to 23.980 mm 0.94327 to 0.94409 in.
Pitman arm bushing I.D.	Factory spec.	24.000 to 24.081 mm 0.94488 to 0.94807 in.

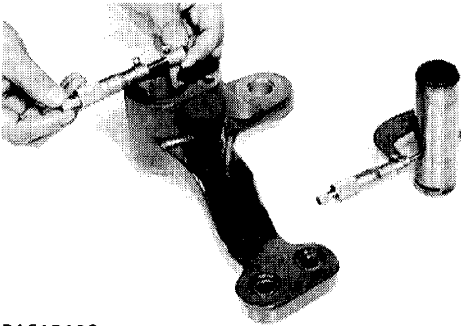

B161P129

**Clearance between Pitman Arm Shaft and Pitman Arm Bushings**

**Bushings**

1. Measure the pitman arm shaft O.D. with an outside micrometer.
2. Measure the pitman arm bushings I.D. with an inside micrometer, and calculate the clearance.
3. If the clearance exceeds the allowable limit, replace the pitman arm bushings.

Clearance between pitman arm shaft and pitman arm bushings	Factory spec.	0.025 to 0.135 mm 0.00098 to 0.00531 in.
	Allowable limit	0.35 mm 0.0138 in.
Pitman arm shaft O.D.	Factory spec.	39.950 to 39.975 mm 1.57283 to 1.57382 in.
Pitman arm bushings I.D.	Factory spec.	40.000 to 40.085 mm 1.57480 to 1.57815 in.



# MECHANISM

## CONTENTS

[1]	HYDRAULIC CIRCUIT .....	8-M1
[2]	STRUCTURE .....	8-M2
[3]	HYDRAULIC CIRCUIT FOR THREE POINT HYDRAULIC SYSTEM .....	8-M3
[4]	HYDRAULIC PUMP .....	8-M4
[5]	OIL FILTER .....	8-M5
[6]	POSITION CONTROL VALVE .....	8-M6
[7]	RELIEF VALVE .....	8-M8
[8]	HYDRAULIC CYLINDER .....	8-M9
[9]	LINKAGE MECHANISM .....	8-M10
	(1) Position Control .....	8-M10
	(2) Position Control with Draft Control .....	8-M12
	(3) Mixed Control .....	8-M14
[10]	HYDRAULIC POWER TAKE OFF .....	8-M14
	(1) Front Hydraulic Block .....	8-M14
	(2) Auxiliary Control Valve .....	8-M15
	(3) Quick Couplers .....	8-M16

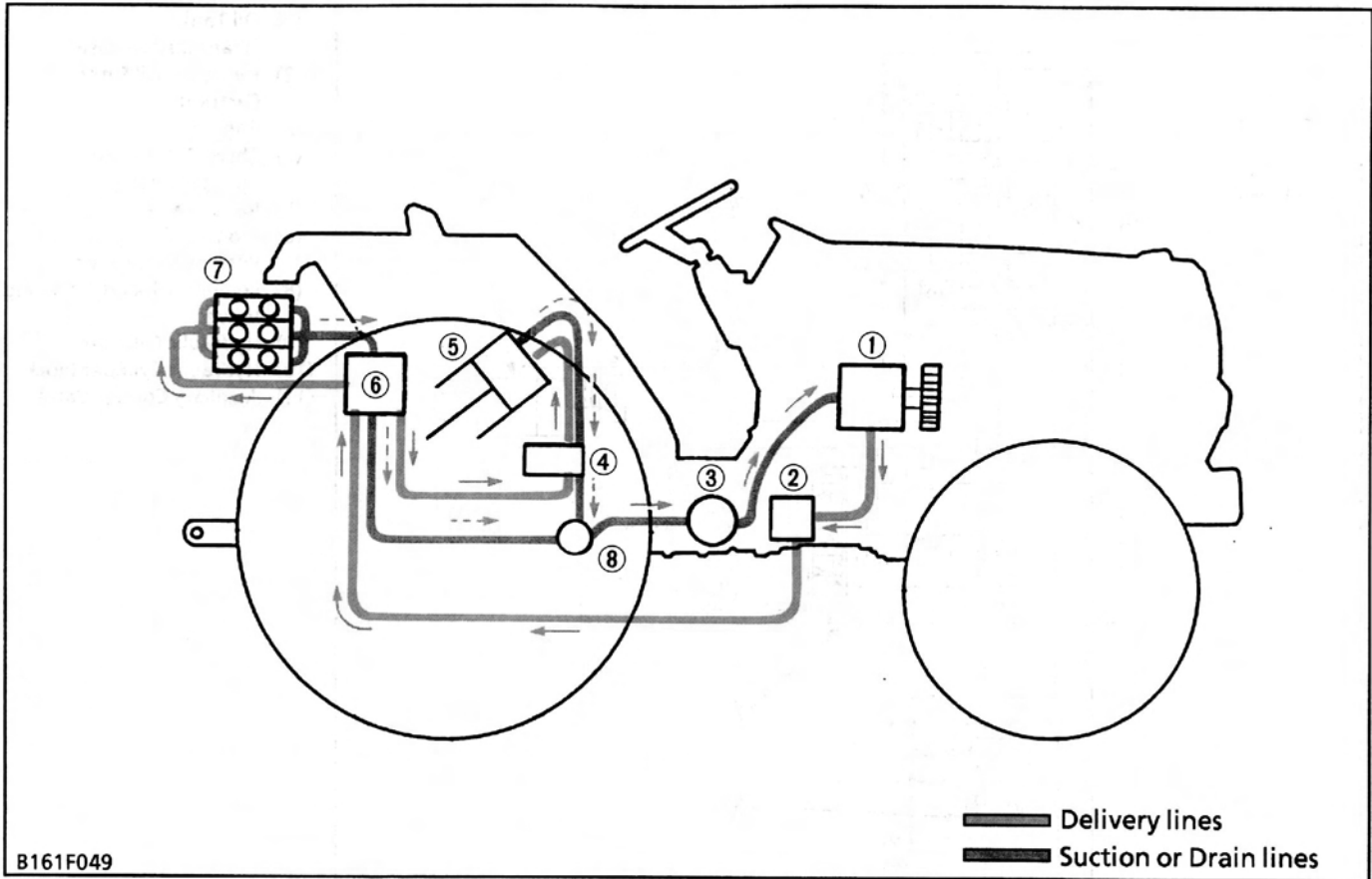
**[2] STRUCTURE**

B161F049

- |   |                                    |  |                                  |
|---|------------------------------------|--|----------------------------------|
| (1) Three Point System Hydraulic Pump         | (3) Hydraulic Oil Filter Cartridge | (5) Hydraulic Cylinder                     | (7) Quick Couplers (If Equipped) |
| (2) Front Hydraulic Block (with Relief Valve) | (4) Position Control Valve         | (6) Auxiliary Control Valves (If Equipped) | (8) Oil Tank (Transmission Case) |

The hydraulic system of these tractors is composed of the main components as shown in the figure. This system has the following three functions.

- To raise and lower the implement connected to the three point hitch. For this motion, the position control valve (4) and the linkage installed on the hydraulic cylinder body provide three different applications' position control, draft control, and mixed control.
- Takes out hydraulic power from the front hydraulic block assembly (2) to operate an implement's hydraulic actuator.
- Takes out hydraulic power from the quick couplers (7) included in the auxiliary control valve assembly (6) (if equipped) for the implements with actuators. In this case, the implement's cylinders can be actuated by operating the auxiliary control valves.

### [3] HYDRAULIC CIRCUIT FOR THREE POINT HYDRAULIC SYSTEM

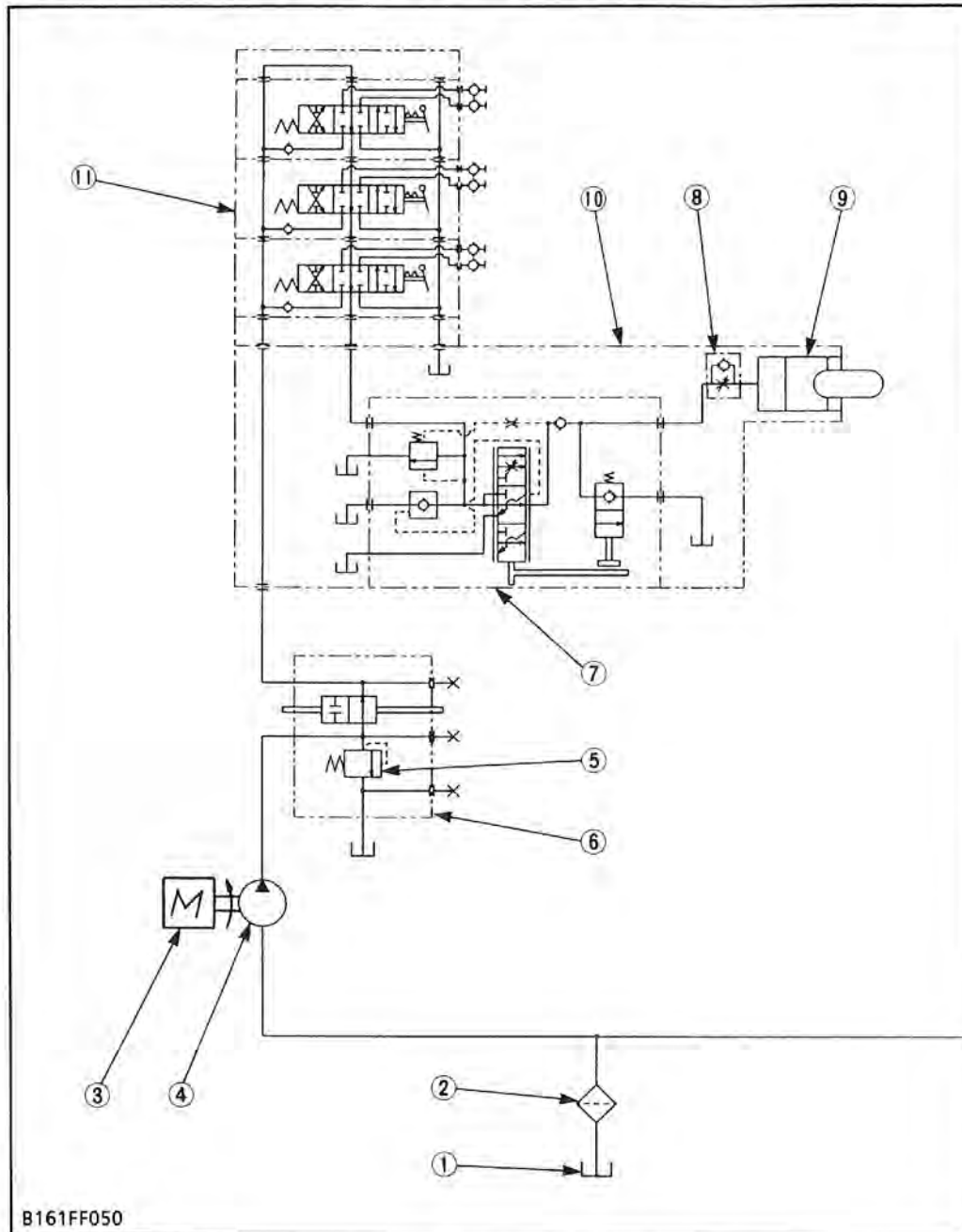

- (1) Oil Tank (Transmission Case)
- (2) Hydraulic Oil Filter Cartridge
- (3) Engine
- (4) Three Point System Hydraulic Pump
- (5) Relief Valve
- (6) Front Hydraulic Block
- (7) Position Control Valve
- (8) Lowering Speed Adjusting Valve
- (9) Hydraulic Cylinder
- (10) Hydraulic Cylinder Block
- (11) Auxiliary Control Valve

#### ■ Hydraulic Oil Flow

1. When the engine (3) is started, the hydraulic pump (4) is rotated to draw oil from the transmission case (1) through the suction pipe. Supplied oil is filtered by the hydraulic oil filter cartridge (2).
  2. Filtered oil is forced out by the hydraulic pump to the front hydraulic block (6). When a front end loader is equipped with the tractor, oil pressure is taken from the front hydraulic block (6), and the return oil from the front end loader flows back to this front hydraulic block (6), to be returned into the oil hydraulic circuit.
  3. After that oil into the position control valve (7) through the delivery pipe.
  4. The position control valve (7) switches the oil flow, and oil is channeled to the hydraulic cylinder (9) for the three-point hydraulic system or returned to the oil tank (transmission case) (1).
- The hydraulic system has a relief valve (5) which restricts the maximum pressure in the circuit.
  - When hydraulic power is taken out to use a hydraulically-operated implement, implement's cylinders can be actuated by operating the double-acting auxiliary control valve (11).

### [4] HYDRAULIC PUMP

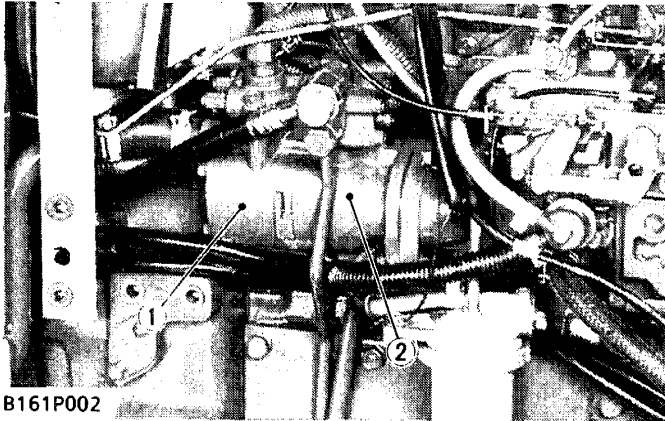

B161P002

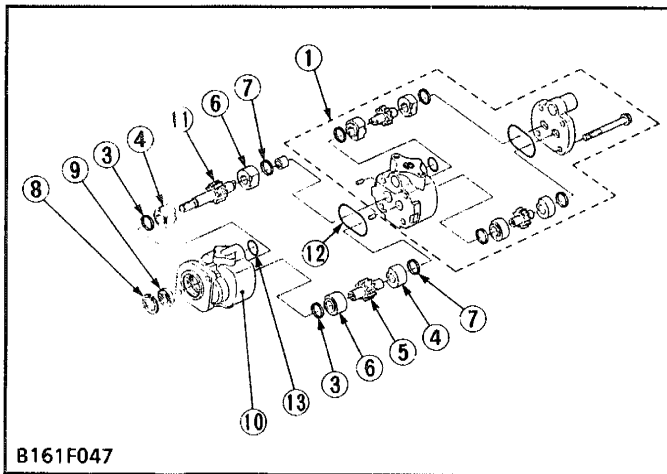

B161F047

The three point system hydraulic pump pressure-feeds the oil drawn from the transmission case through the oil filter to the control valve. The three point system hydraulic pump is driven by the engine fuel camshaft.

This hydraulic pump is pressure loading type gear pump with high volumetric efficiency.

**(Reference)**

Pump discharge per revolution	L3010	9.027 cc/rev.
	L3410	0.551 cu.in./rev.
Pump discharge at no pressure	L3010	26.4 ℓ / min
	L3410	6.97 U.S.gal / min
Pump discharge at rated pressure	L3010	25.6 ℓ / min
	L3410	6.76 U.S.gal / min
Pump discharge at no pressure	L3710	11.69 cc/rev.
	L4310	0.713 cu.in./rev.
Pump discharge at no pressure	L3710	29.5 ℓ / min
	L4310	7.79 U.S.gal / min
Pump discharge at rated pressure	L3710	28.6 ℓ / min
	L4310	7.56 U.S.gal / min
Pump discharge at rated pressure	L3710	6.49 Imp.gal / min
	L4310	6.29 Imp.gal / min

- (1) Power Steering Hydraulic Pump
- (2) Three Point System Hydraulic Pump
- (3) Seal Ring
- (4) Bushing
- (5) Driven Gear
- (6) Bushing
- (7) Seal Ring
- (8) Internal Snap Ring
- (9) Oil Seal
- (10) Pump Body
- (11) Drive Gear
- (12) O-ring
- (13) O-ring

**■ Operation**

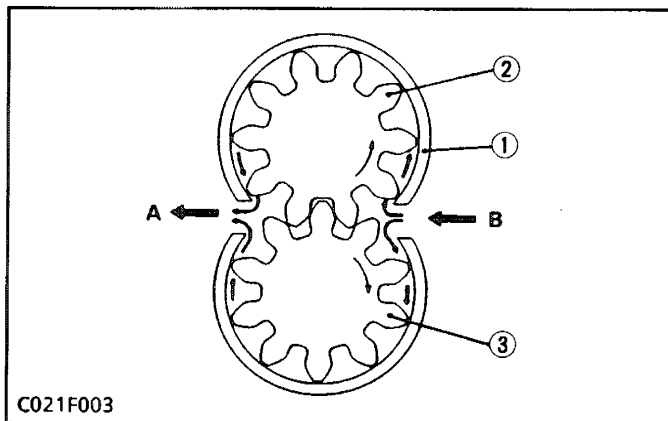

C021F003

The hydraulic pump has two meshing gears (2), (3) whose teeth run close to the casing (1). One gear is a drive gear which drives the driven gear. When the drive gear is driven in the direction of the arrow by the fuel camshaft, the gear traps oil between the gear teeth and the casing. The higher the engine speed, the more the pump discharges.

- A : Outlet
- B : Inlet
- (1) Casing
- (2) Gear
- (3) Gear

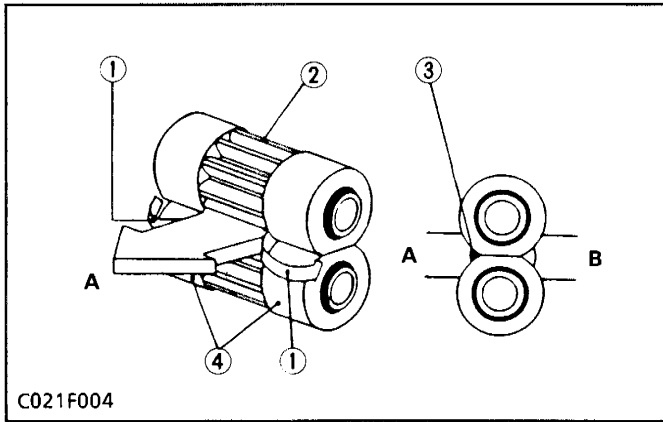

The pressure loading system automatically decreases the clearance between the gear and the bushings. A small amount of pressurized oil is fed behind the bushings, pressing them against the gears and forming a tighter seal against leakage. Therefore, leakage from the delivery side (high pressure) to the inlet side (low pressure) does not increase even if the pressure on the delivery side increases.

A: Outlet

B: Inlet

- (1) Loading Pressure
- (2) Gear

- (3) Pressure Introducing Port
- (4) Bushings

### [5] OIL FILTER

The oil filter is located at the pump suction line.

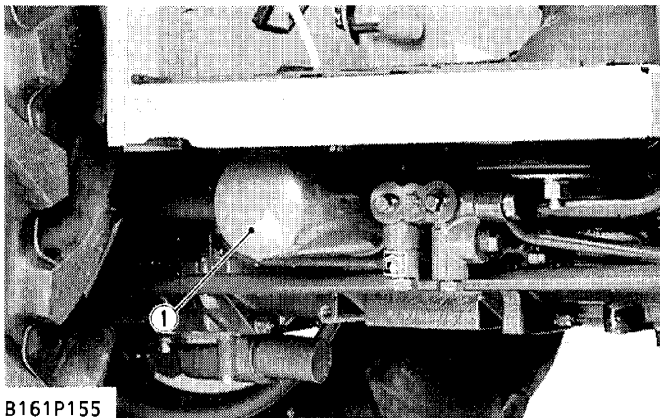

This oil filter is cartridge type, and located in the right side of clutch housing case.

The filtration degree of this filter is  $\beta_{60}$  or  $BETA_{60} = 2.5$  (MIN). \*

\*

This is authorized by ISO / 4572 Filter Element Multi-Pass Test.

$\beta_a =$  (The number of particles which are more than a  $\mu m$  diameter before passing filter.) / (The number of the same size of particles after passing filter.)

- (1) Hydraulic Oil Filter Cartridge

## [6] POSITION CONTROL VALVE

This position control valve is located under the hydraulic cylinder block.

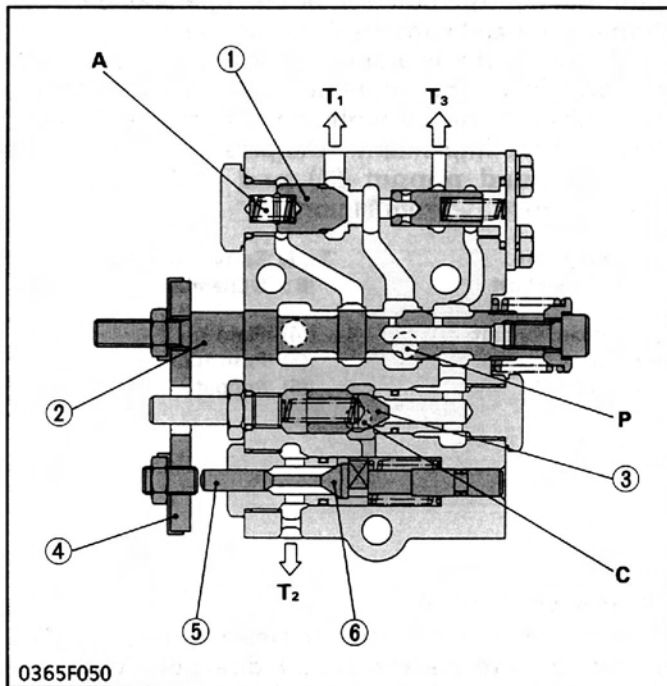

### ■ Neutral

Pressurized oil flows at the P port, pushes open unload poppet (1) and returns to the transmission case from T1 port.

The oil in the A chamber behind the unload poppet returns to the transmission case through the clearance between spool (2) and control valve. The oil in the hydraulic cylinder does not flow out because the circuit is cut off by the actions of poppet 1 (3) and poppet 2 (6).

P : Pump Port

C : Cylinder Port

(1) Unload Poppet

(2) Spool

(3) Poppet 1

T1, T2, T3 : Tank Port

A : A Chamber

(4) Plate 1

(5) Push Rod

(6) Poppet 2

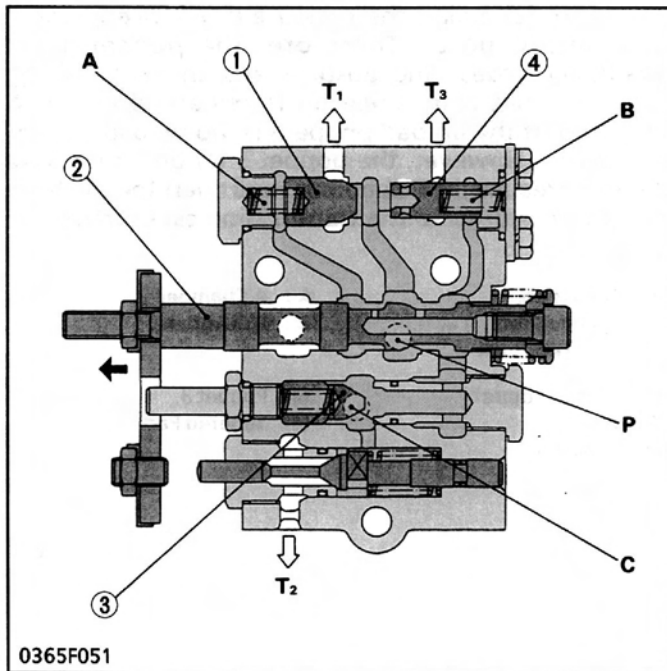

### ■ Lift

When the control lever is moved to UP, spool (2) moves to arrow-mark direction.

The oil entered P port flows into the A chamber, B chamber and closes unload poppet (1), poppet 3 (4).

The pressure in the circuit slowly rises, pushing open poppet 1 (3), and the hydraulic oil flows into the hydraulic cylinder from the C port, lifting the implement.

P : Pump Port

C : Cylinder Port

T1, T2, T3 : Tank Port

(1) Unload Poppet

(2) Spool

A : A Chamber

B : B Chamber

(3) Poppet 1

(4) Poppet 3



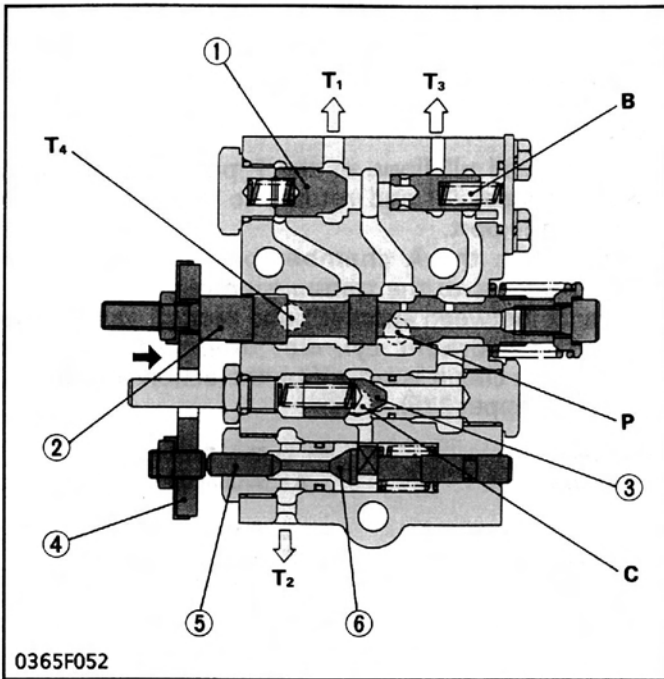

■ Down

When the control lever is moved to **DOWN**, spool (2) moves to arrow-mark direction, and pushes the push rod (5). The push rod pushes open poppet 2 (6), forming a circuit with the C port and T2 port.

The oil in the hydraulic cylinder is forced out by the weight of the implement, and returns to the transmission case through the C port and T2 port, lowering the implement. The pressurized oil pushes open unload poppet (1) and returns to the transmission case from T1 port.

- |                          |                                   |
|--------------------------|-----------------------------------|
| <b>P</b> : Pump Port     | <b>T1, T2, T3, T4</b> : Tank Port |
| <b>C</b> : Cylinder Port | <b>B</b> : B Chamber              |
| (1) Unload Poppet        | (4) Plate 1                       |
| (2) Spool                | (5) Push Rod                      |
| (3) Poppet 1             | (6) Poppet 2                      |

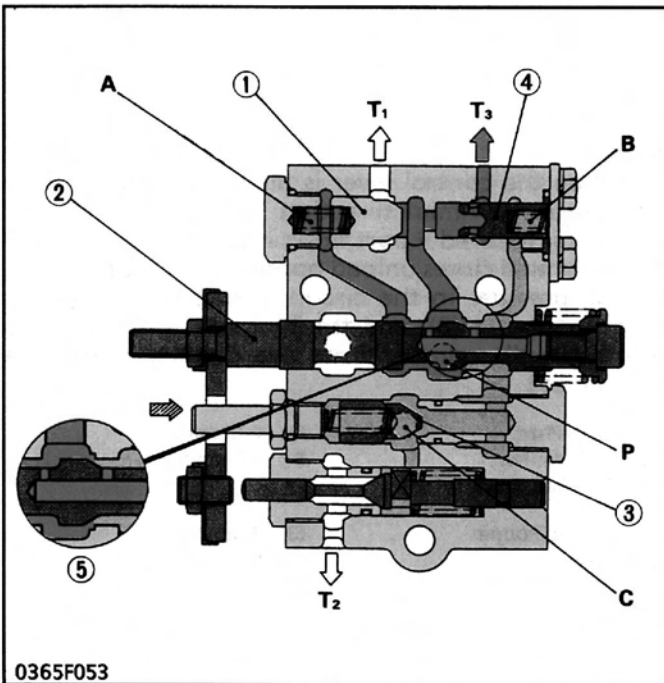

■ Lifting to Neutral

In returning from Lifting to Neutral, the spool (2) is pushed back to the arrow-mark direction. When the **Neutral** position comes near, the tapered part (5) of the spool (2) makes the pressure difference at the P port and C port. Therefore, the poppet 1 (3) gradually closes, and absorbs any shock at lifting stop. In that case, since oil is remained in the A chamber of the unload poppet (1), no unload poppet (1) opens. However, the poppet 3 (4) opens because of low pressure in B chamber, and then the oil from the pump returns to the transmission case through T3 port.

- |                               |                      |
|-------------------------------|----------------------|
| <b>P</b> : Pump Port          | <b>A</b> : A Chamber |
| <b>C</b> : Cylinder Port      | <b>B</b> : B Chamber |
| <b>T1, T2, T3</b> : Tank Port |                      |
| (1) Unload Poppet             | (4) Poppet 3         |
| (2) Spool                     | (5) Tapered Part     |
| (3) Poppet 1                  |                      |

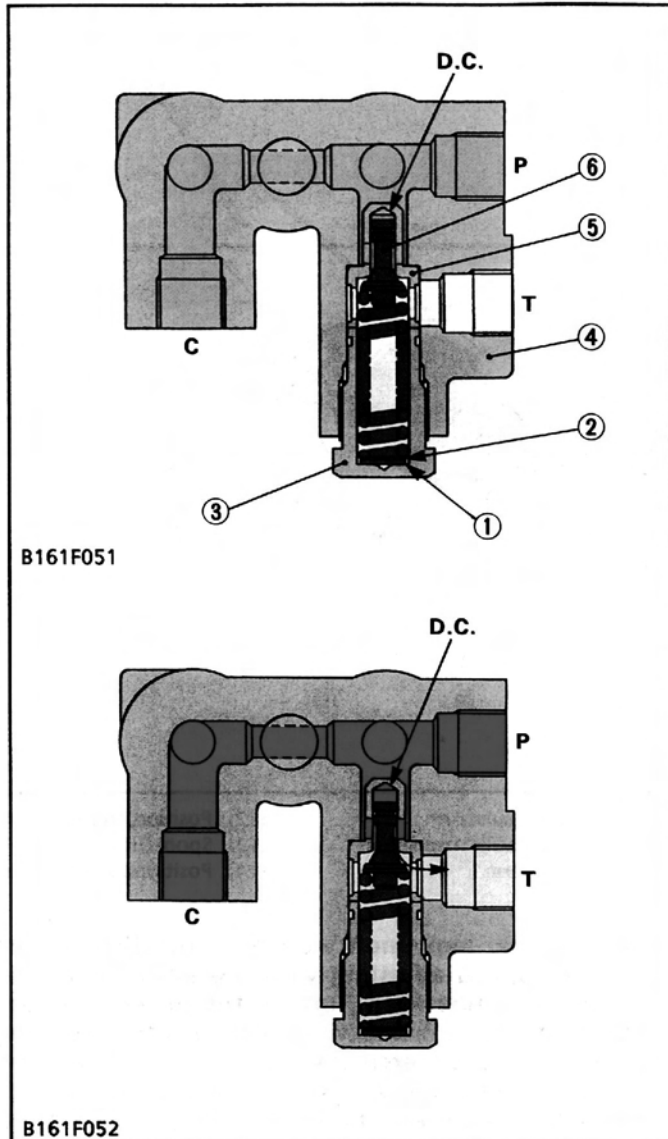
**[7] RELIEF VALVE**

The Three point hydraulic system circuit has a relief valve to restrict the maximum pressure in the circuit. The relief valve is incorporated in the front hydraulic block.

The relief valve is of the guide piston type with damping effect.

Among direct acting relief valves, this type is suited to higher pressure and has large capacity. Furthermore, this type is free from unstable operation, such as chattering, which occurs often in direct acting relief valves.

As shown in the figure, the guide is attached to the poppet (6) and a valve chamber D.C. (called the damping chamber) is formed at the bottom of the guide piston. The inlet of the valve leads to the chamber via a clearance between the sliding portion of the guide and the seat (5), minimizing valve vibration with the damping effect of the chamber.

When the oil pressure in the circuit is lower than the setting pressure of the relief valve, the relief valve is not operated and the oil fed to the relief valve from the hydraulic pump flows into the in-port of the hydraulic cylinder.

As the oil pressure in the circuit increases, so does the pressure in the damping chamber D.C. When the pressure rises above the valve setting and overcomes the spring force, the valve opens. Oil then flows out to the transmission case through T port, preventing any further rise in pressure. The valve closes again when enough oil is released to drop pressure below the valve setting.

**(Reference)**

- Relief Valve setting pressure : 16.2 to 17.2 MPa  
165 to 175 kgf/cm<sup>2</sup>  
2347 to 2489 psi
- Engine speed : Maximum
- Oil temperature : 40 to 60 °C  
104 to 140 °F

D.C. : Damping Chamber  
P : Pump Port

C : Cylinder Port  
T : Tank Port

- (1) Washer
- (2) Shim
- (3) Plug

- (4) Front Hydraulic Block
- (5) Seat
- (6) Poppet

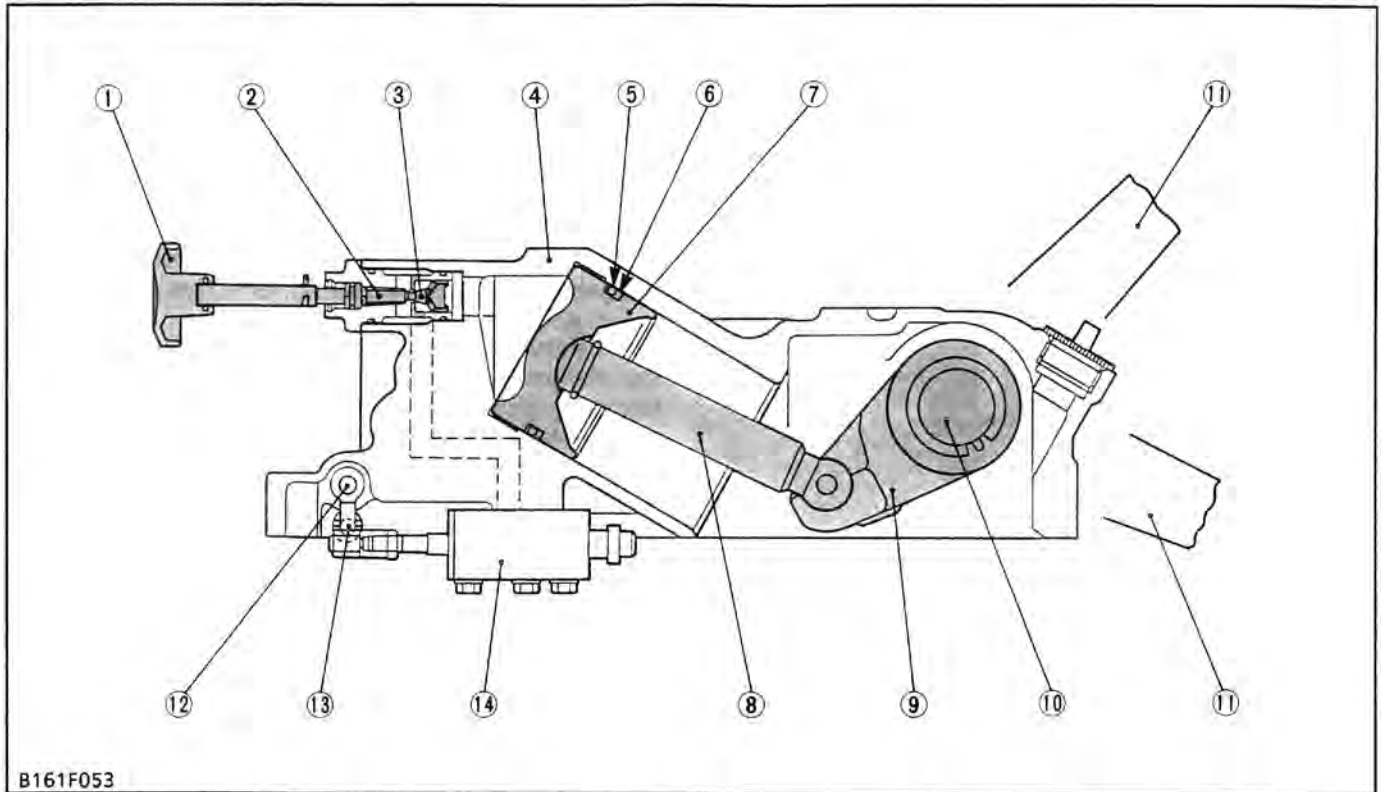
**[8] HYDRAULIC CYLINDER**

B161F053

- |                                    |                      |                          |                             |
|------------------------------------|----------------------|--------------------------|-----------------------------|
| (1) Lowering Speed Adjusting Knob  | (5) O-ring           | (9) Hydraulic Arm        | (12) Position Control Arm   |
| (2) Lowering Speed Adjusting Shaft | (6) Back-up Ring     | (10) Hydraulic Arm Shaft | (13) Spool Drive Lever      |
| (3) Lowering Speed Adjusting Valve | (7) Hydraulic Piston | (11) Lift Arm            | (14) Position Control Valve |
| (4) Hydraulic Cylinder             | (8) Hydraulic Rod    |                          |                             |

The main components of the hydraulic cylinder are shown in the figure above.

While the lift arm (11) is rising, oil from the hydraulic pump flows into the hydraulic cylinder through the position control valve (14). Then oil pushes out the piston (7).

While the lift arm (11) is lowering, oil in the hydraulic cylinder is discharged to the transmission case through the position control valve (14) by the weight of the implement. At this time, the lowering

speed of the implement can be controlled by the lowering speed adjusting valve (3) attached to the hydraulic cylinder (4). Turning the lowering speed adjusting knob (1) clockwise decreases the lowering speed, and counterclockwise increases lowering speed. When the lowering speed adjusting valve (3) is completely closed, the lift arm (11) is held at its position since oil in the hydraulic cylinder is sealed between the piston (7) and lowering speed adjusting valve (3).

## [9] LINKAGE MECHANISM

### (1) Position Control

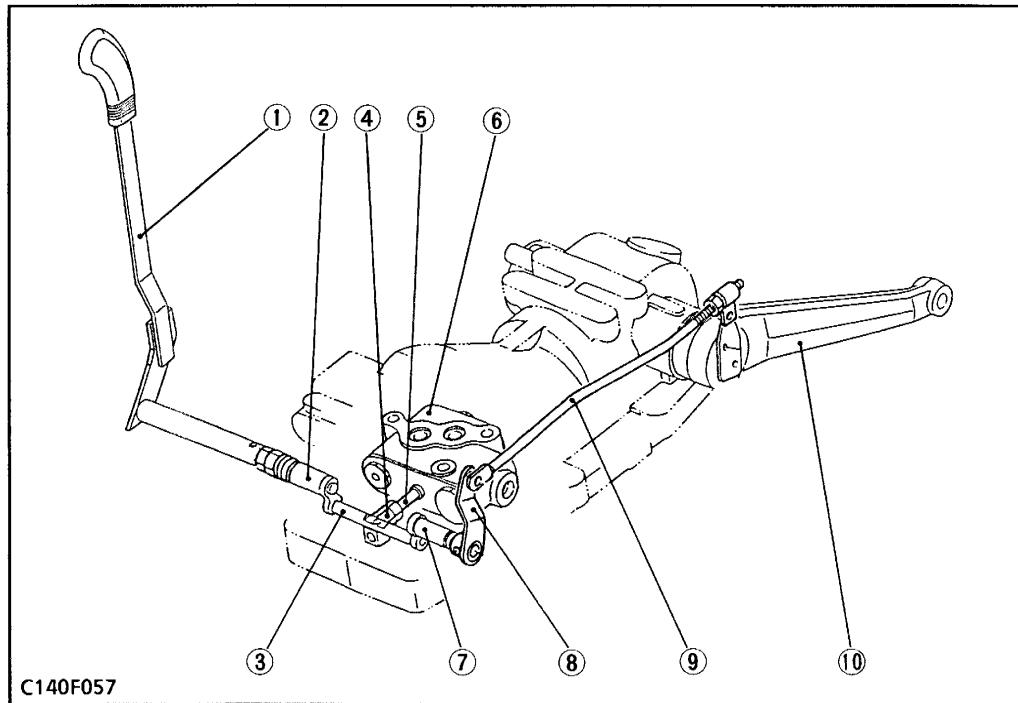

- (1) Position Control Lever
- (2) Control Arm
- (3) Spool Drive Lever
- (4) Spool Joint 1
- (5) Spool Head
- (6) Valve Body
- (7) Feedback Lever Shaft
- (8) Feedback Lever
- (9) Feedback Rod
- (10) Lift Arm

Position control is a mechanism to raise or lower the implement attached to the tractor in proportion to the movement of the control lever.

The implement can be positioned at any height by moving the position control lever. Fine position adjustment is also easy.

#### ■ Lift

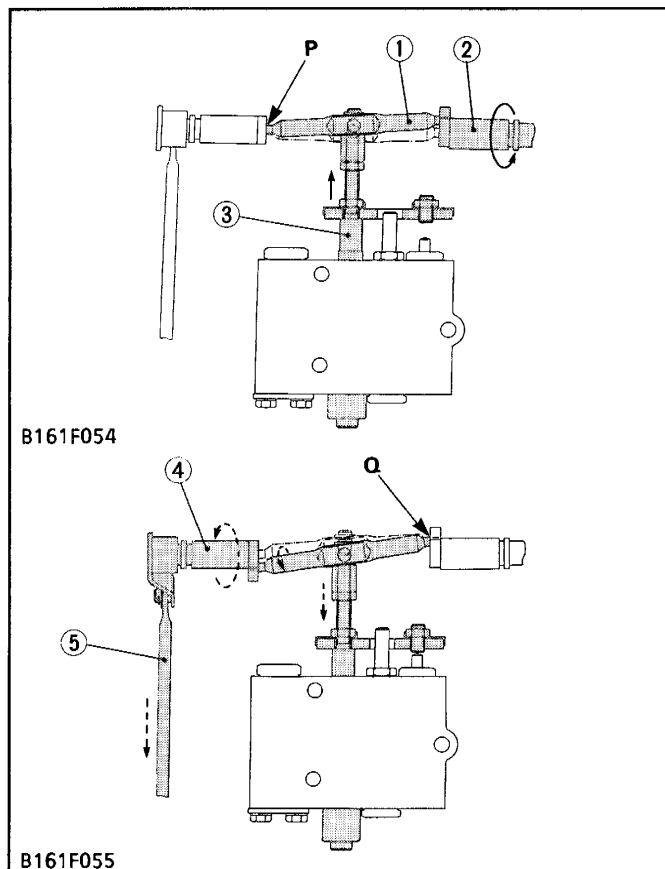

1. When the position control lever is moved to the **LIFT** position, the control arm (2) rotates to the arrow. Therefore, the spool drive lever (1) moves around the fulcrum **P** and pull the spool (3) opening the **LIFT** circuit.
2. When the lift arm moves upward, the feedback lever shaft (4) is rotated to the arrow, since the feedback rod (5) is actuated. Therefore, the spool drive lever (1) moves around the fulcrum **Q** and pushes the spool (3).
3. The lift arm stops when the spool returns to the neutral position.

- (1) Spool Drive Lever
- (2) Control Arm
- (3) Spool
- (4) Feedback Lever Shaft
- (5) Feedback Rod

■ Down

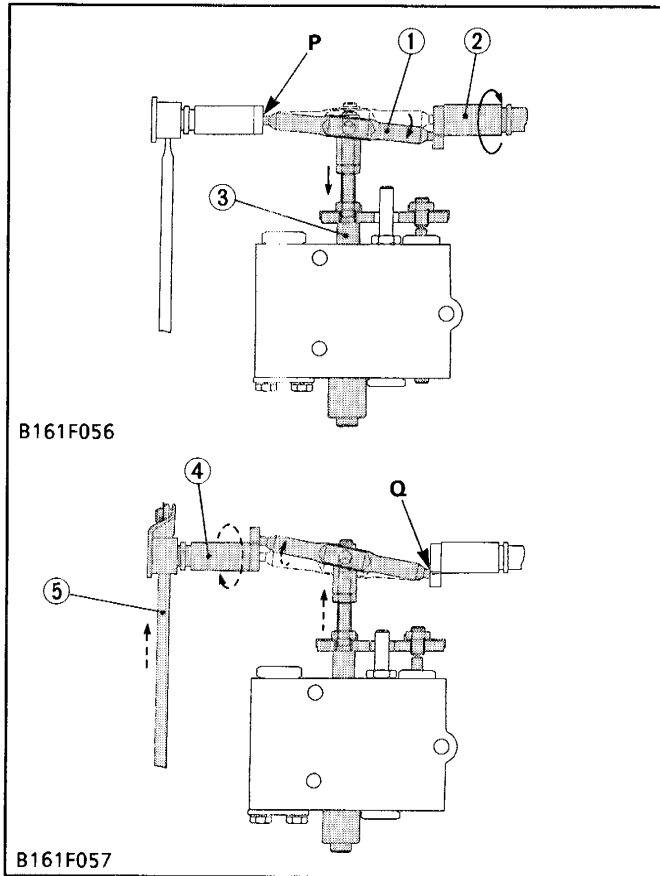

1. When the position control lever is moved to the **DOWN** position, the control arm (2) rotates to the arrow. Therefore, the spool drive lever (1) moves around the fulcrum **P** and pull the spool (3) opening the **DOWN** circuit.
2. When the lift arm moves downward, the feedback lever shaft (4) is rotated to the arrow, since the feedback rod (5) is actuated. Therefore, the spool drive lever (1) moves around the fulcrum **Q** and pushes the spool (3).
3. The lift arm stops when the spool (3) returns to the neutral position.

(1) Spool Drive Lever

(2) Control Arm

(3) Spool

(4) Feedback Lever Shaft

(5) Feedback Rod

## (2) Position Control with Draft Control

Draft control is a system which maintains a constant traction load, and is suited for the work which needs heavy traction load such as plowing.

The implement is automatically raised when its traction load is increased, and lowers when the traction load is decreased. By maintaining a constant load level, it prevents the tractor from slipping and being loaded excessively. The setting traction load can be adjusted by changing the position of the draft control lever.

The draft control system uses the same control valve as the position control system. Therefore it is possible to use the mixed control. The traction load applied to the tractor is sensed and is fed back to the control valve by means of the other linkage mechanism.

### ■ Position Control Operation

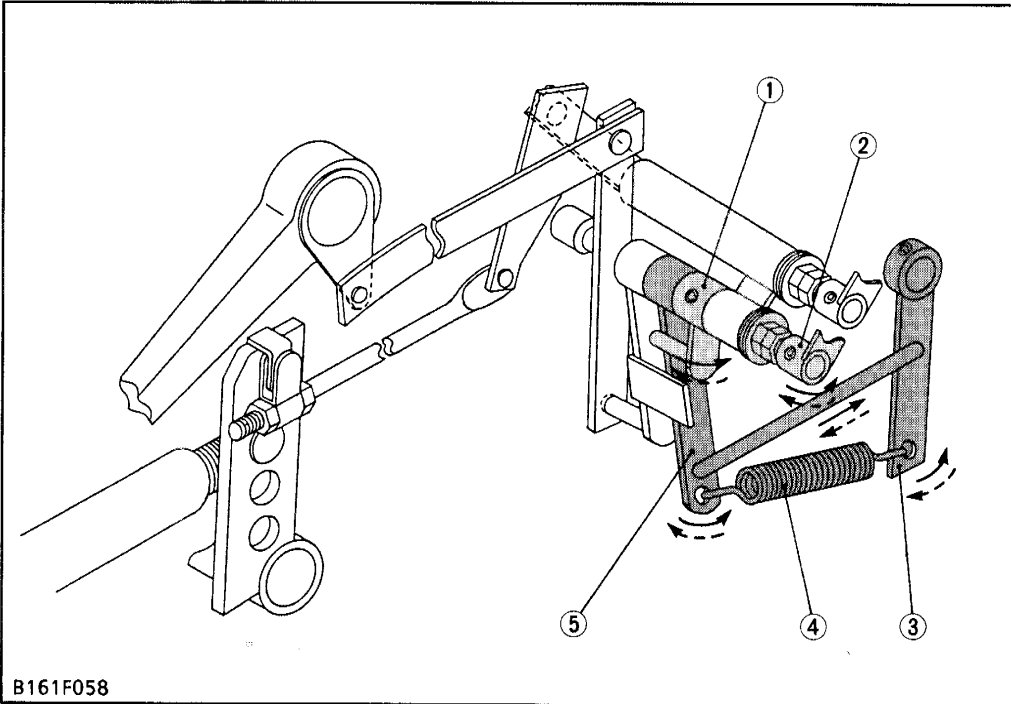

- (1) Position Control Link
- (2) Position Control Lever
- (3) Arm 2
- (4) Return Spring
- (5) Arm 1

#### ● Lift (→)

1. When the position control lever (2) is moved to the **LIFT** side, the position control link (1) is also rotated and pushes the arm 1 (5).
2. At the same time, the arm 2 (3) is moved, the connected position control valve becomes the lift circuit, and the lift arm goes up.

#### ● Down (←)

1. When the position control lever (2) is moved to the **DOWN** side, the position control link (1) is also rotated.
2. By this action, the arm 2 (3) and the arm 1 (5) are returned by the return spring (4).
3. The position control valve becomes the down circuit and the lift arm is lowered.

#### (Reference)

- For the feedback mechanism of the position control, refer to "(1) Position Control".

## ■ Draft Control Operation

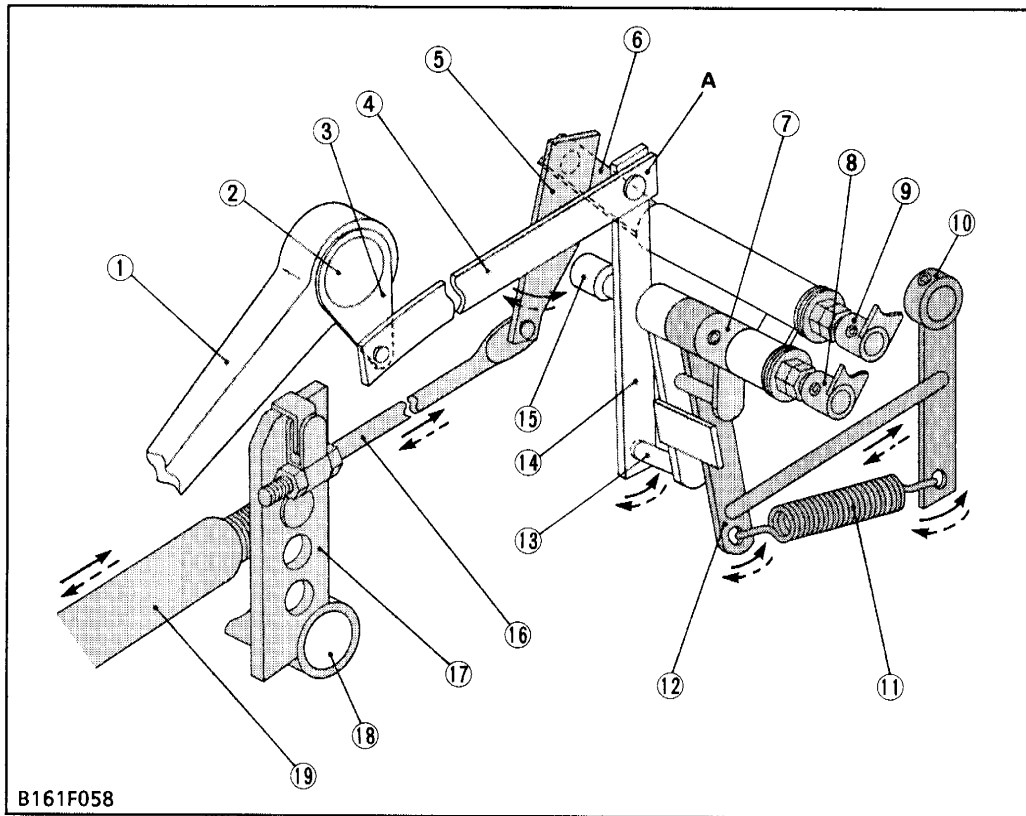

- (1) Lift Arm
- (2) Hydraulic Arm Shaft
- (3) Feedback Rod Stay
- (4) Feedback Rod
- (5) Draft Cam
- (6) Draft Control Lever Shaft
- (7) Position Control Link
- (8) Position Control Lever
- (9) Draft Control Lever
- (10) Arm 2
- (11) Return Spring
- (12) Arm 1
- (13) Draft Control Link 1
- (14) Draft Control Link 2
- (15) Roller
- (16) Draft Control Rod
- (17) Top Link Holder
- (18) Torsion Bar
- (19) Top Link

B161F058

When the draft control lever (9) is operated in the draft control operating range, the draft control lever shaft (6) is rotated, causing the draft cam (5) to move toward the roller (15) installed on the draft control link 2 (14).

### (Reference)

- The sensitivity of the draft control can be adjusted by changing the gap between the draft cam (5) and the roller (15) by the draft control lever (9).

### ■ Movement of the Link Under Increased Load (→)

1. When the traction load is increased, the torsion bar (18) is twisted according to the load, the draft control rod (16) and the draft cam (5) are pushed to come into contact with the roller (15).
2. Using the A portion as the fulcrum, the draft control link 2 (14) and the draft control link 1 (13) move to push the arm 1 (12).
3. At the same time, the arm 2 (10) is moved, the connected position control valve becomes the lift circuit, and the lift arm (1) goes up.

### ■ Movement of the Link Under decreased Load (←)

1. When the lift arm (1) goes up, the traction load is decreased, and the draft control rod (16) is returned.
2. At the same time, the arm 2 (10), arm 1 (12), and draft control link 1 (13) are returned by the return spring (11).
3. The position control valve becomes the down circuit, and the lift arm (1) is lowered.

### (Reference)

- The feedback rod (4) of the draft control is provided to maintain the positional relation of the draft cam (5) and the roller (15) to certain state regardless of the height of the lift arm (1).

### (3) Mixed Control

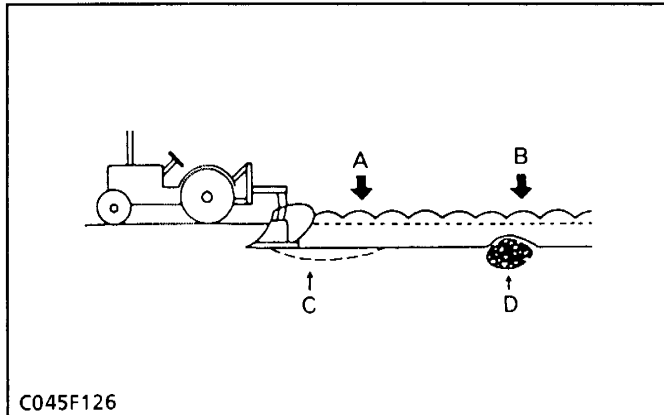

- (A) Position Controlled  
 (B) Draft Controlled  
 (C) Not Deep Even in Soft Soil  
 (D) Shallow where Resistance Occurs

Mixed control is a system combining position control with draft control.

When traction load increases, the draft control functions to raise the lift arms (implement). When traction load decreases, the lift arms (implement) lower to the height set by the position control lever.

With the position control only when traction load increases, slippage or engine stop may occur unless the implement is raise.

With the draft control only, plowing depth cannot be kept constant if soil hardness changes greatly.

The mixed control serves to eliminate such disadvantages.

## [10] HYDRAULIC POWER TAKE OFF

If necessary, hydraulic power for implements can be taken out from front hydraulic block or using auxiliary control valves and quick couplers.

- Hydraulic power for the front loader can be taken out from front hydraulic block.
- On L3010, L3410, L3710 and L4310 tractor's auxiliary control valve assembly is an optional unit. Quick couplers are included in the auxiliary control valve assembly.

### ■ IMPORTANT

- When taking out hydraulic power, replenish transmission oil in the quantity equal to the flow rate required for the implement cylinder.

### ■ NOTE

- Before attaching the implement, check the type and contamination of oil in the implement hydraulic circuit.

### (1) Front Hydraulic Block

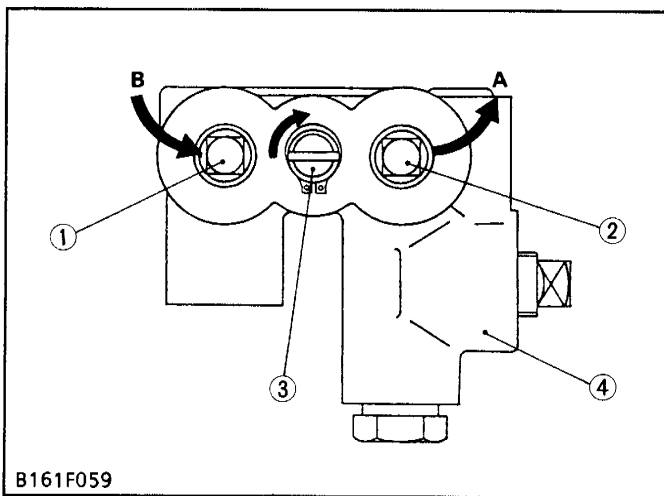

B161F059

- Remove the plugs from OUT port (2) and IN port (1) of the front hydraulic block (4).
- Install the hydraulic take off adaptors (screw size PT 3/8") to OUT port and IN port.
- Connect the hydraulic hose to the adaptor (OUT port side) and to the implement control valve IN port.
- Connect the other hydraulic hose to the adaptor (IN port side) and to the implement control valve TANK (RETURN) port.
- Turn the slit on the spool (3) end to the arrow side fully as shown in the figure.

### ■ NOTE

- When implement is not attached, turn the slit on the spool end to the horizontal position fully.

- A : To Implement Control Valve IN Port  
 B : From Implement Control Valve TANK Port  
 C : When implement is not attached position  
 D : When implement is attached position

- (1) IN Port Plug  
 (2) OUT Port Plug  
 (3) Spool  
 (4) Front Hydraulic Block

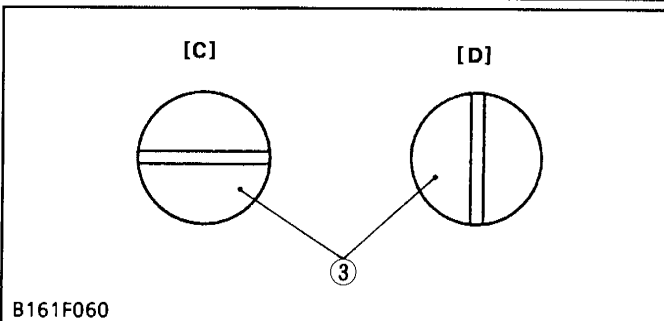

B161F060

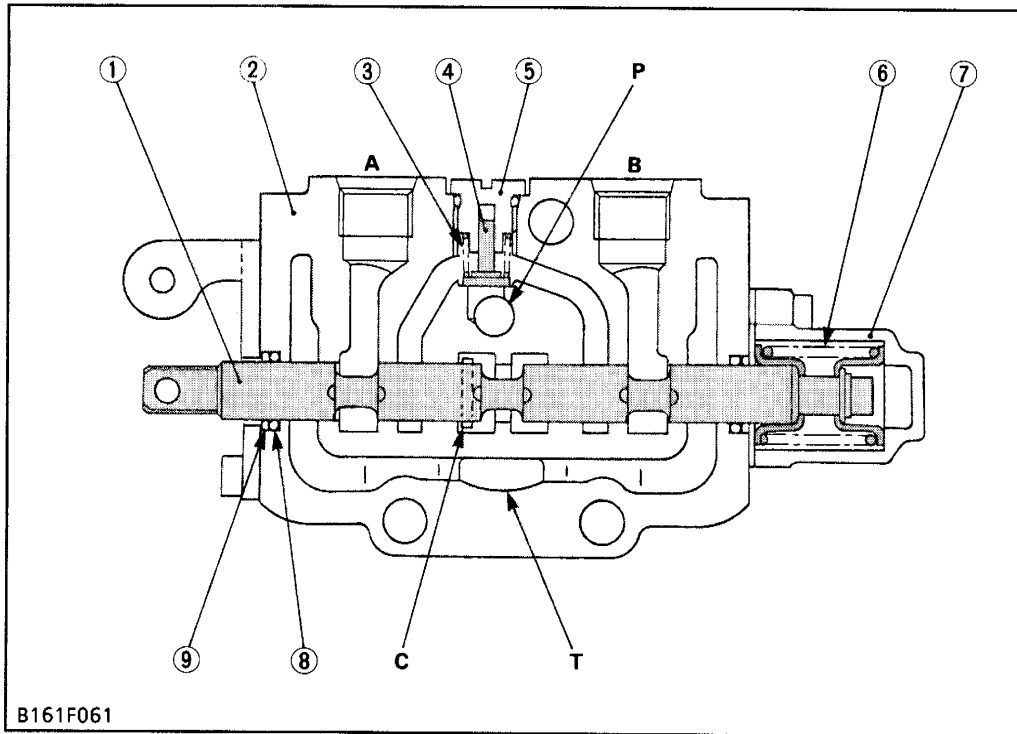

**(2) Auxiliary Control Valve**

**P : Pump Port**  
**C : Out Port**  
**(To Position Control Valve)**  
**T : Tank Port**  
**A, B : Implement Cylinder Ports**

- (1) Spool
- (2) Valve Body
- (3) Spring
- (4) Check Valve
- (5) Plug
- (6) Return Spring
- (7) Spring Cap
- (8) O-ring
- (9) Back-up Ring

A double-acting type auxiliary control valve is used, and the construction is shown in the figure above.

When the spool (1) is at neutral position, the oil flows in from the pump port to push up the check valve (4), and flows out from the out port. The oil coming from the out port flows into the position control valve.

When the auxiliary control valve operating lever is

moved to the implement cylinder actuating position, the spool (1) is moved and the oil from the pump port flows into A or B, causing the implement cylinder to operate.

The return oil from the implement cylinder flows out of the tank port through A or B and returns to the transmission case. The oil to the out port is blocked and will not flow to the position control valve.

### (3) Quick Couplers

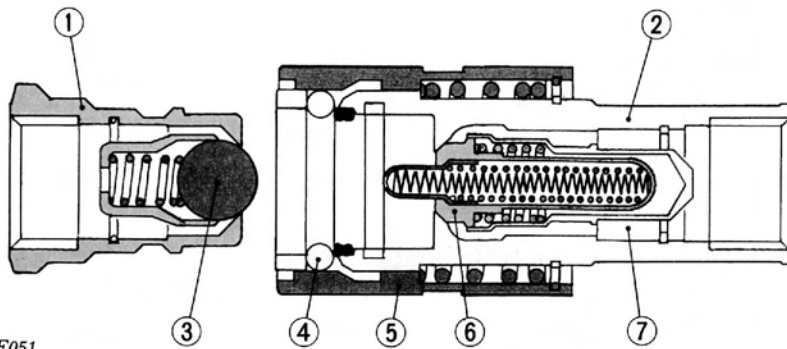

#### Operation

1. Coupled condition, both valves closed

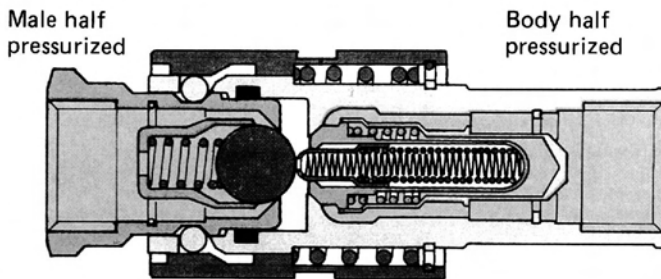

2. Release pressure on body half. Body valve opens.

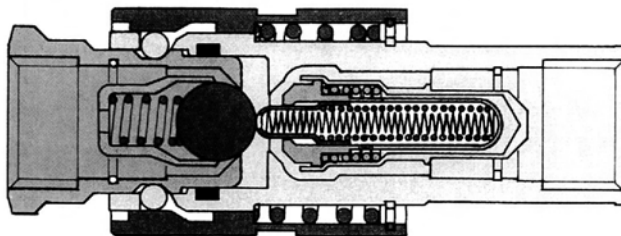

3. Pressurized body half to open male half valve.

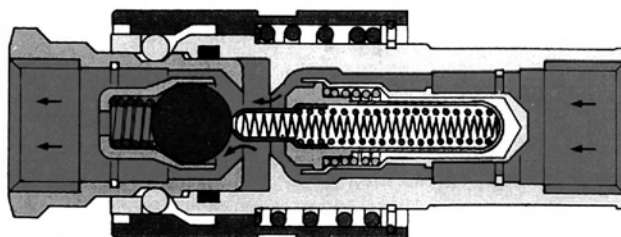

Quick couplers provided with these tractors are connectable even under pressure with both halves or either half pressurized.

To connect the male half (1) to the body half (2), slide the sleeve (5) to the rear on the body half and insert the male half into the body half. Move the sleeve (5) forward to seat the steel balls (4) for locking the male half (1) into the body half (2).

The male half (1) is locked in place by a ring of steel balls (4) which is held in a groove on the inserted male half by the outer sleeve (5).

- (1) Male Half
- (2) Body Half (Female Half)
- (3) Steel Ball
- (4) Steel Ball
- (5) Sleeve
- (6) Poppet
- (7) Guide

# SERVICING

## CONTENTS

<b>TROUBLESHOOTING</b> .....	8-S1
<b>SERVICING SPECIFICATIONS</b> .....	8-S2
<b>TIGHTENING TORQUES</b> .....	8-S3
<b>CHECKING, DISASSEMBLING AND SERVICING</b> .....	8-S4
<b>[1] HYDRAULIC PUMP</b> .....	8-S4
<b>CHECKING</b> .....	8-S4
(1) Pump Test Using Flow-meter .....	8-S4
<b>DISASSEMBLING AND ASSEMBLING</b> .....	8-S6
(1) Removing Hydraulic Pump Assembly .....	8-S6
(2) Disassembling Three Point System Hydraulic Pump .....	8-S7
<b>SERVICING</b> .....	8-S8
<b>[2] POSITION CONTROL AND DRAFT CONTROL LINKAGE</b> .....	8-S9
<b>CHECKING AND ADJUSTING</b> .....	8-S9
<b>DISASSEMBLING AND ASSEMBLING</b> .....	8-S10
<b>[3] RELIEF VALVE</b> .....	8-S13
<b>CHECKING AND ADJUSTING</b> .....	8-S13
<b>DISASSEMBLING AND ASSEMBLING</b> .....	8-S13
<b>[4] HYDRAULIC CYLINDER AND POSITION CONTROL VALVE</b> .....	8-S14
<b>DISASSEMBLING AND ASSEMBLING</b> .....	8-S14
(1) Removing Hydraulic Cylinder Assembly .....	8-S14
(2) Disassembling Hydraulic Cylinder Assembly .....	8-S17
<b>SERVICING</b> .....	8-S20



## TROUBLESHOOTING

Symptom	Probable Cause	Solution	Reference Page
Implement Does Not Rise (Not Noise)	<ul style="list-style-type: none"> <li>● Control linkage improperly adjusted</li> <li>● Control linkage improperly assembled or damaged</li> <li>● Position control valve malfunctioning</li> <li>● Relief valve spring weaken or broken</li> <li>● Hydraulic piston O-ring, cylinder damaged</li> </ul>	Adjust Repair or replace	8-S9 8-S12, S18
(Noise)	<ul style="list-style-type: none"> <li>● Transmission fluid improper or insufficient</li> <li>● Oil filter clogged</li> <li>● Suction pipe loosen or broken</li> <li>● Relief valve setting pressure too low</li> <li>● Relief valve spring weaken or damaged</li> <li>● Hydraulic pump malfunctioning</li> </ul>	Repair or replace Replace Replace Change or replenish Replace Repair or replace Adjust Replace Repair or replace	8-S19 8-S13 8-S17 G-13 G-12 - 8-S13 8-S13 8-S6 to S8
Implement Does Not Reach Maximum Height	<ul style="list-style-type: none"> <li>● Position control feedback rod improperly adjusted</li> <li>● Top link length improperly adjusted</li> <li>● Position control valve spool joint 1 improperly adjusted</li> <li>● Hydraulic arm shaft, hydraulic arm, lift arm improperly assembled</li> <li>● Three point link improperly set</li> </ul>	Adjust Adjust Adjust Adjust	8-S9 - 8-S19 8-S17 -
Implement Does Not Lower	<ul style="list-style-type: none"> <li>● Position control valve malfunctioning               <ul style="list-style-type: none"> <li>● Spool damaged</li> <li>● Poppet 2, push rod improperly adjusted</li> </ul> </li> <li>● Draft control rod improperly adjusted</li> </ul>	Replace Adjust Adjust	8-S19 8-S19 8-S10
Implement Drops by Weight	<ul style="list-style-type: none"> <li>● Hydraulic cylinder worn or damaged</li> <li>● Hydraulic piston O-ring worn or damaged</li> <li>● Lowering speed adjusting valve damaged</li> <li>● Position control valve malfunctioning               <ul style="list-style-type: none"> <li>● Poppet 1 seat surface damaged</li> <li>● Poppet 1 seat plug O-ring damaged</li> <li>● Poppet 2 seat surface damaged</li> <li>● Poppet 2 seat plug O-ring damaged</li> </ul> </li> </ul>	Replace Replace Replace Replace Replace Replace Replace Replace	8-S20 8-S17 8-S20 8-S19 8-S19 8-S19 8-S19
Implement Hunts (Moves Up and Down)	<ul style="list-style-type: none"> <li>● Position control valve malfunctioning               <ul style="list-style-type: none"> <li>● Poppet 1 seat surface damaged</li> <li>● Poppet 1 seat plug O-ring damaged</li> <li>● Poppet 2 seat surface damaged</li> <li>● Poppet 2 seat plug O-ring damaged</li> </ul> </li> <li>● Poppet 2, push rod improperly adjusted</li> </ul>	Replace Replace Replace Replace Adjust	8-S19 8-S19 8-S19 8-S19 8-S19
Draft Control Malfunctioning	<ul style="list-style-type: none"> <li>● Draft control linkage improperly adjusted</li> <li>● Torsion bar weaken or broken</li> </ul>	Adjust Replace	8-S10 -
Oil Temperature Increases Rapidly	<ul style="list-style-type: none"> <li>● Relief valve operating</li> <li>● Hydraulic pump leak or damaged</li> <li>● Oil leaks from valves</li> <li>● Gear or bearing damaged in the transmission case</li> </ul>	Adjust Repair or replace Repair or replace Replace	8-S13 8-S5, S7 - -

# SERVICING SPECIFICATIONS

## THREE POINT SYSTEM HYDRAULIC PUMP

Item		Factory Specification	Allowable Limit
Hydraulic Pump <b>Condition</b> <ul style="list-style-type: none"> <li>● Engine Speed               <ul style="list-style-type: none"> <li>[L3010 · L3410] .. Approx. 2700 rpm</li> <li>[L3710 · L4310] .. Approx. 2600 rpm</li> </ul> </li> <li>● Rated Pressure .. 16.2 to 17.2 MPa 165 to 175 kgf/cm<sup>2</sup> 2347 to 2489 psi</li> <li>● Oil Temperature ... 40 to 60 °C 104 to 140 °F</li> </ul>	Delivery at No Pressure [L3010 · L3410]	Above 26.4 ℓ / min 6.97 U.S.gal / min 5.81 Imp.gal / min	–
	[L3710 · L4310]	Above 29.5 ℓ / min 7.79 U.S.gal / min 6.49 Imp.gal / min	–
	Delivery at Rated Pressure [L3010 · L3410]	Above 25.6 ℓ / min 6.76 U.S.gal / min 5.63 Imp.gal / min	23.0 ℓ / min 6.08 U.S.gal / min 5.06 Imp.gal / min
	[L3710 · L4310]	Above 28.6 ℓ / min 7.56 U.S.gal / min 6.29 Imp.gal / min	25.7 ℓ / min 6.79 U.S.gal / min 5.65 Imp.gal / min
Housing	Depth of Scratch	–	0.09 mm 0.0035 in.
Bushing to Gear Shaft	Clearance	–	0.12 mm 0.0043 in.
Bushing	Length [L3010 · L3410]	22.99 to 23.00 mm 0.9051 to 0.9055 in.	22.80 mm 0.8976 in.
	[L3710 · L4310]	20.49 to 20.50 mm 0.8067 to 0.8071 in.	20.30 mm 0.7992 in.

## RELIEF VALVE

Relief Valve <b>Condition</b> <ul style="list-style-type: none"> <li>● Engine Speed ..... Maximum</li> <li>● Oil Temperature ... 40 to 60 °C 104 to 140 °F</li> </ul>	Setting Pressure	16.2 to 17.2 MPa 165 to 175 kgf/cm <sup>2</sup> 2347 to 2489 psi	–
--	------------------	--	---

## CONTROL LINKAGE

Lift Arm	Free Play (at Maximum Raising Position)	5 to 10 mm 0.19 to 0.39 in.	–
----------	--	--------------------------------	---

**HYDRAULIC CYLINDER**

Item		Factory Specification	Allowable Limit
Cylinder Bore	I.D.	90.000 to 90.050 mm 3.54330 to 3.54527 in.	90.150 mm 3.54921 in.
Hydraulic Arm Shaft to Bushing	Clearance (Right)	0.125 to 0.230 mm 0.00492 to 0.00906 in.	0.50 mm 0.0197 in.
	(Left)	0.125 to 0.220 mm 0.00492 to 0.00866 in.	0.50 mm 0.0197 in.
Hydraulic Arm shaft	O.D. (Right)	44.920 to 44.950 mm 1.76850 to 1.76968 in.	–
	(Left)	39.920 to 39.950 mm 1.57165 to 1.57283 in.	–
Bushing	I.D. (Right)	45.075 to 45.150 mm 1.77460 to 1.77756 in.	–
	(Left)	40.075 to 40.140 mm 1.57775 to 1.58031 in.	–

**TIGHTENING TORQUES**

Tightening torques of screws and nuts on the table below are especially specified.  
(For general use screws and nuts : See page G-9)

Item	N·m	kgf·m	ft-lbs
Delivery pipe joint bolt (Three point system hydraulic pump to front hydraulic block)	49.0 to 58.8	5.0 to 6.0	36.2 to 43.4
GST · independent PTO delivery pipe joint bolt	34.3 to 39.2	3.5 to 4.0	25.3 to 28.9
Power steering delivery hose joint bolt	49.0 to 58.8	5.0 to 6.0	36.2 to 43.4
Delivery pipe joint bolt (Power steering hydraulic pump to regulator valve)	39.3 to 49.0	4.0 to 5.0	29.0 to 36.2
Regulator valve mounting screws	17.6 to 20.6	1.8 to 2.1	13.0 to 15.2
Hydraulic pump assembly mounting screw and nut	23.6 to 27.4	2.4 to 2.8	17.4 to 20.2
Rear wheel mounting stud bolt	98.1 to 112.7	10.0 to 11.5	72.3 to 83.1
Rear wheel mounting screws and nuts	197 to 226	20 to 23	145 to 166
Control linkage assembly mounting screws	23.6 to 27.4	2.4 to 2.8	17.4 to 20.2
Arm 2 lock nut	29.4 to 39.2	3.0 to 4.0	21.7 to 28.9
Relief valve plug	49.0 to 68.6	5.0 to 7.0	36.2 to 50.6
ROPS mounting screws			
M12, grade 7 screw	77.5 to 90.2	7.9 to 9.2	57.1 to 66.5
M14, grade 9 screw	166.7 to 196.1	17.0 to 20.0	123 to 144
M16, grade 11 screw	260.9 to 304.0	26.6 to 31.0	192 to 224
9/16-18 UNF, grade 8 screw	149.1 to 179.5	15.2 to 18.3	110 to 132
GST shift cable mounting screws	7.8 to 8.8	0.8 to 0.9	5.8 to 6.5
Floor seat mounting bolts and nuts	197 to 226	20 to 23	145 to 166
Hydraulic cylinder assembly mounting stud bolts	34.3 to 49.0	3.5 to 5.0	25.3 to 36.2
Hydraulic cylinder assembly mounting screws and nuts	77.4 to 90.2	7.9 to 9.2	57.1 to 66.5
Position control valve mounting screws	23.6 to 27.4	2.4 to 2.8	17.4 to 20.2

# CHECKING, DISASSEMBLING AND SERVICING

## [1] HYDRAULIC PUMP

### CHECKING

#### (1) Pump Test Using Flow-meter

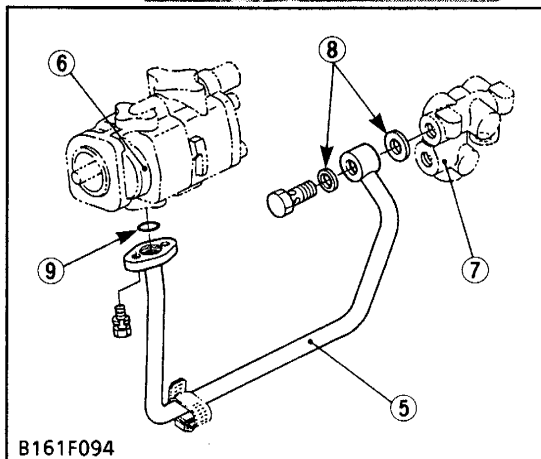
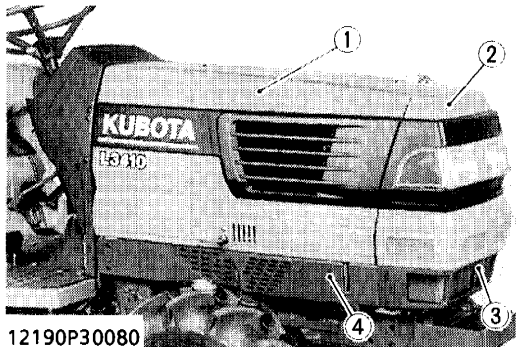

#### Preparation

1. Remove the side cover RH (1) and front mask (2).
2. Remove the front grille (3) and side skirt RH (4).
3. Remove the delivery pipe (5) between the three point system hydraulic pump (6) and front hydraulic block (7).

#### (When reassembling)

- Install the copper washers (8) and O-ring (9) firmly.

Tightening torque	Delivery pipe joint bolt	49.0 to 58.8 N·m 5.0 to 6.0 kgf·m 36.2 to 43.4 ft-lbs

- |                   |                                       |
|-------------------|---------------------------------------|
| (1) Side Cover RH | (6) Three Point System Hydraulic Pump |
| (2) Front Mask    | (7) Front Hydraulic Block             |
| (3) Front Grille  | (8) Copper Washers                    |
| (4) Side Skirt RH | (9) O-ring                            |
| (5) Delivery Pipe |                                       |



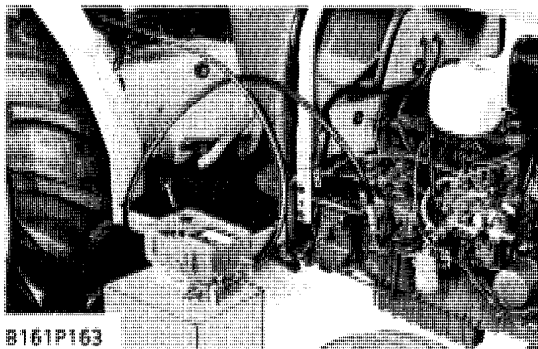

B161P163

**Condition**

- Engine speed  
 [L3010 · L3410] ..... Approx. 2700 rpm  
 [L3710 · L4310] ..... Approx. 2600 rpm
- Rated pressure ..... 16.2 to 17.2 MPa  
 165 to 175 kgf/cm<sup>2</sup>  
 2347 to 2489 psi
- Oil temperature ..... 40 to 60 °C  
 104 to 140 °F

**Hydraulic Flow Test**

■ **IMPORTANT**

- When using a flowmeter other than KUBOTA specified flowmeter, be sure to use the instructions with that flowmeter.
- Do not close the flowmeter loading valve completely, before testing, because it has no relief valve.

1. Install the adaptor 61 with O-ring to the pump discharge port.
2. Connect the hydraulic test hose to the adaptor 61 and flowmeter inlet port.
3. Connect the other hydraulic test hose to the flowmeter outlet port and to transmission fluid filling plug hole.
4. Open the flowmeter loading valve completely. (Turn counterclockwise.)
5. Start the engine and set the engine speed at 2000 to 2200 rpm.
6. Slowly close the loading valve to generate pressure approx. 14.7 MPa (150 kgf/cm<sup>2</sup>, 2133 psi). Hold in this condition until oil temperature reaches approx. 40 °C (104 °F).
7. Open the loading valve completely.
8. Set the engine speed. (Refer to Condition.)
9. Read and note the pump delivery at no pressure.
10. Slowly close the loading valve to increase pressure approx. 17.16 MPa (175 kgf/cm<sup>2</sup>, 2489 psi). As the load is increased, engine speed drops, therefore, reset the engine speed.
11. Read and note the pump delivery at rated pressure.
12. Open the loading valve completely and stop the engine.
13. If the pump delivery does not reach the allowable limit, check the pump suction line, oil filter or hydraulic pump.

Hydraulic pump delivery at no pressure	Factory spec.	L3010 L3410	Above 26.4 ℓ / min 6.97 U.S.gal / min 5.81 Imp.gal / min
		L3710 L4310	Above 29.5 ℓ / min 7.79 U.S.gal / min 6.49 Imp.gal / min
Hydraulic pump delivery at rated pressure	Factory spec.	L3010 L3410	Above 25.6 ℓ / min 6.76 U.S.gal / min 5.63 Imp.gal / min
		L3710 L4310	Above 28.6 ℓ / min 7.56 U.S.gal / min 6.29 Imp.gal / min
	Allowable limit	L3010 L3410	23.0 ℓ / min 6.08 U.S.gal / min 5.06 Imp.gal / min
		L3710 L4310	25.7 ℓ / min 6.79 U.S.gal / min 5.65 Imp.gal / min

## DISASSEMBLING AND ASSEMBLING

### ■ IMPORTANT

- The hydraulic pump is precision machined and assembled : if disassembled once, it may be unable to maintain its original performance. Therefore, when the hydraulic pump fails, replacement should be carried out with the hydraulic pump assembled except when emergency repair is unavoidable.
- When repair is required, follow the disassembly and servicing procedures shown below with utmost care.
- Be sure to test the hydraulic pump with a flowmeter before disassembling.
- After reassembly, be sure to perform break-in operation and ensure that there is nothing abnormal with the hydraulic pump.

### (1) Removing Hydraulic Pump Assembly

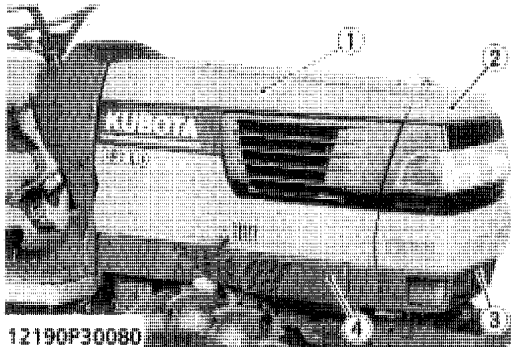

#### Preparation 1

1. Remove the side cover RH (1) and front mask (2).
2. Remove the front grille (3) and side skirt RH (4).

- (1) Side Cover RH
- (2) Front Mask
- (3) Front Grille
- (4) Side Skirt RH

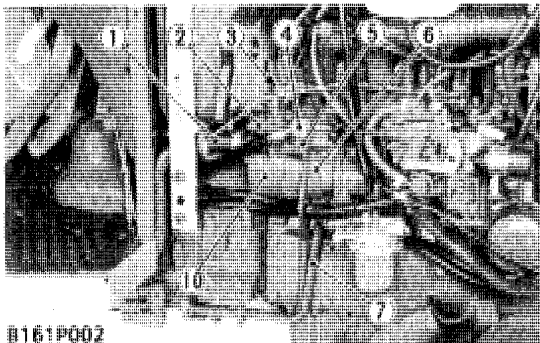

#### Preparation 2

1. Disconnect the GST-independent PTO delivery pipe (5), power steering delivery hose (4) and power steering return hose (3) from the regulator valve (2).
2. Remove the delivery pipe (8).
3. Disconnect the delivery pipe (7) from the three point system hydraulic pump (6).
4. Disconnect the suction rubber hose (1).

#### (When reassembling)

- Apply grease to the O-rings and take care not to damage them.
- Install the copper washers (9) firmly.

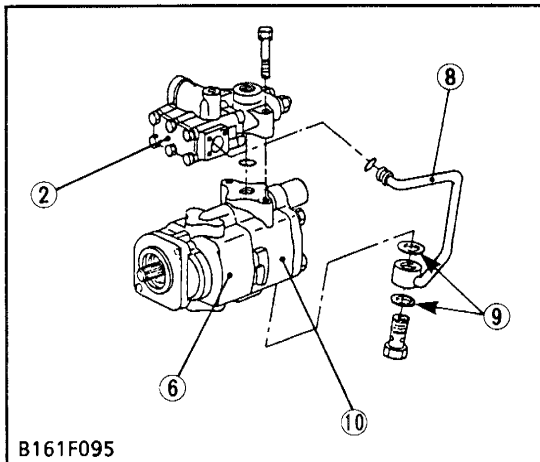

Tightening torque	GST-independent PTO delivery pipe joint bolt	34.3 to 39.2 N·m 3.5 to 4.0 kgf·m 25.3 to 28.9 ft-lbs
	Power steering delivery hose joint bolt	49.0 to 58.8 N·m 5.0 to 6.0 kgf·m 36.2 to 43.4 ft-lbs
	Delivery pipe (8) joint bolt	39.3 to 49.0 N·m 4.0 to 5.0 kgf·m 29.0 to 36.2 ft-lbs

- (1) Suction Rubber Hose
- (2) Regulator Valve
- (3) Power Steering Return Hose
- (4) Power Steering Delivery Hose
- (5) GST-Independent PTO Delivery Pipe
- (6) Three Point System Hydraulic Pump
- (7) Delivery Pipe
- (8) Delivery Pipe
- (9) Copper Washers
- (10) Power Steering Hydraulic Pump

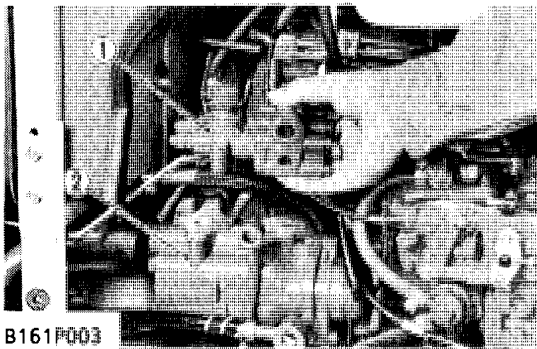

B161P003

**Regulator Valve**

1. Loosen and remove the regulator valve mounting screws.
2. Take out the regulator valve (1) from the power steering hydraulic pump (2).

**(When reassembling)**

- Apply grease to the O-ring and take care not to damage it.

Tightening torque	Regulator valve mounting screws	17.6 to 20.6 N·m 1.8 to 2.1 kgf·m 13.0 to 15.2 ft·lbs
-------------------	---------------------------------	---

(1) Regulator Valve

(2) Power Steering Hydraulic Pump

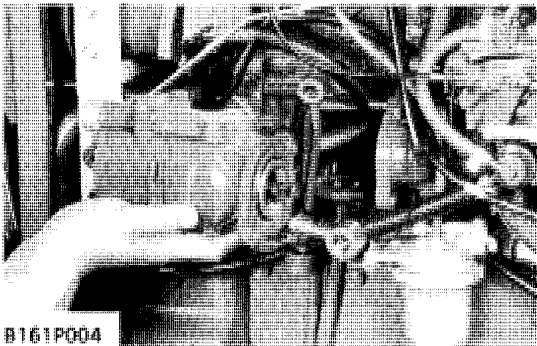

B161P004

**Removing Hydraulic Pump Assembly**

1. Loosen and remove the hydraulic pump assembly mounting screw and nut.
2. Take out the hydraulic pump assembly.

**(When reassembling)**

- Apply grease to the O-ring and take care not to damage it.

Tightening torque	Hydraulic pump assembly mounting screw and nut	23.6 to 27.4 N·m 2.4 to 2.8 kgf·m 17.4 to 20.2 ft·lbs
-------------------	--	---

**(2) Disassembling Three Point System Hydraulic Pump**

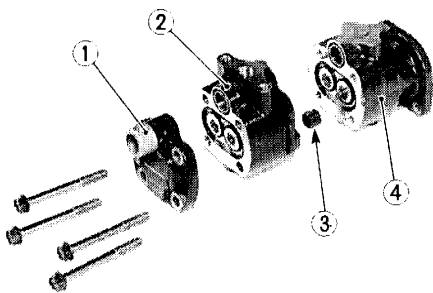

B161P005

**Separating Power Steering Hydraulic Pump**

1. Remove the pump cover mounting four screws.
2. Separate the power steering hydraulic pump (2) from the three point system hydraulic pump (4).

**(When reassembling)**

- Take care not to damage the O-rings.

(1) Pump Cover

(3) Coupling

(2) Power Steering Hydraulic Pump

(4) Three Point System Hydraulic Pump

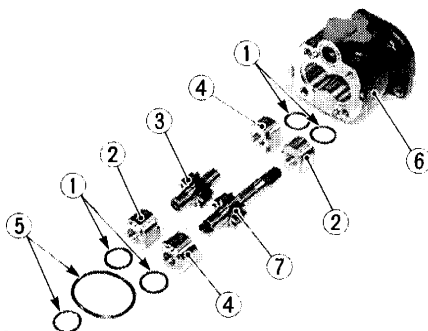

B161P007

**Disassembling Three Point System Hydraulic Pump**

1. Remove the O-ring (5) and seal ring (1).
2. Remove the bushings (2), (4) as a unit.
3. Take out the drive gear (7) and driven gear (3).
4. Take out the bushings (2), (4) in back of pump housing (6) as a unit.

**(When reassembling)**

- Install the driven gear (3), noting its original direction.
- When installing the bushings (2), (4), be sure to reassemble them to the each original position.
- Take care not to damage the seal rings and O-rings.
- After reassembling the hydraulic pump assembly, mount an arm approx. 100 mm (3.93 in.) long to the drive gear to check for smooth rotation.

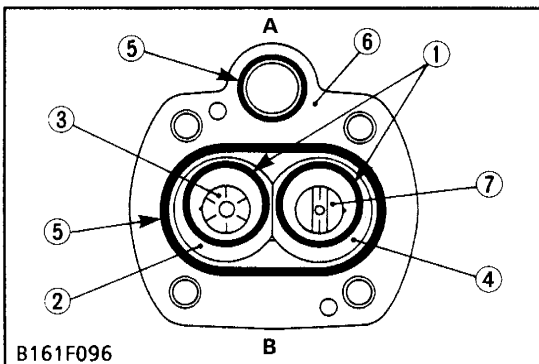

B161F096

[A] Inlet

[B] Outlet

(1) Seal Ring

(5) O-ring

(2) Bushing

(6) Pump Housing

(3) Driven Gear

(7) Drive Gear

(4) Bushing

**Hydraulic Pump Running-In**

After reassembly, perform break-in operation in the following manner, and check the pump for abnormality before use. If the pump temperature should rise noticeably during running-in, recheck should be performed.

1. Install the hydraulic pump to the tractor, and mount the suction pipe and delivery pipe securely.
2. Set the engine speed at 1300 to 1500 rpm, and operate the hydraulic pump at no load for about 10 minutes.
3. Set the engine speed at 2000 to 2200 rpm, and with the hydraulic pump applied with 2.94 MPa (30 kgf/cm<sup>2</sup>, 427 psi) to 4.90 MPa (50 kgf/cm<sup>2</sup>, 711 psi) pressure, operate it for approx. 15 minutes.
4. With the engine set to maximum speed, then actuate the relief valve five times for 25 seconds (one time 5 seconds).

**SERVICING**

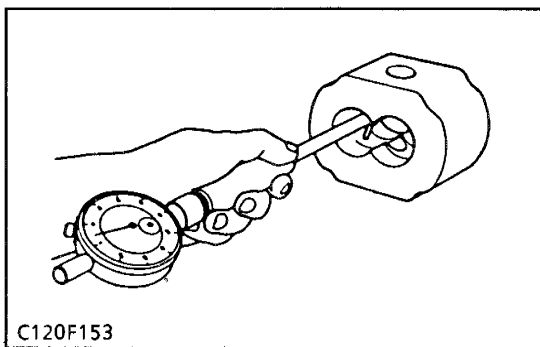

**Housing Bore (Depth of Scratch)**

1. Check for the scratch on the interior surface of the housing caused by the gear.
2. If the scratch reaches more than half the area of the interior surface of the housing, replace at pump assembly.
3. Measure the housing I.D. where the interior surface is not scratched, and measure the housing I.D. where the interior surface is scratched.
4. If the values obtained in the two determinations differ by more than the allowable limit, replace the hydraulic pump as a unit.

Depth of scratch	Allowable limit	0.09 mm 0.0035 in.
------------------	-----------------	-----------------------

**(Reference)**

- Use a cylinder gauge to measure the housing I.D.

**Clearance between Bushing and Gear Shaft**

1. Measure the gear shaft O.D. with an outside micrometer.
2. Measure the bushing I.D. with an inside micrometer, and calculate the clearance.
3. If the clearance exceeds the allowable limit, replace the gear shaft and the bushings as a unit.

Clearance between bushing and gear shaft	Allowable limit	0.12 mm 0.0043 in.
--	-----------------	-----------------------

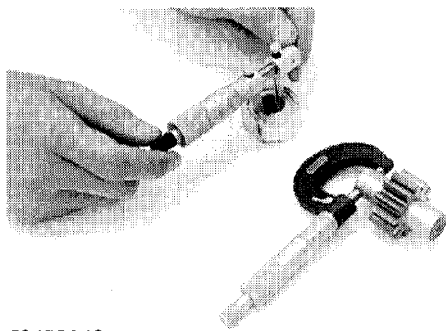

**Bushing Length**

1. Measure the bushing length with an outside micrometer.
2. If the length is less than the allowable limit, replace the bushings and gears as a unit.

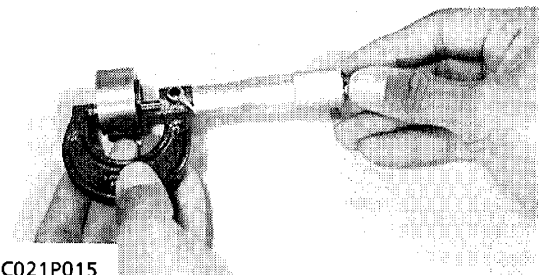

Bushing length	Factory spec.	L3010	22.99 to 23.00 mm
		L3410	0.9051 to 0.9055 in.
	Allowable limit	L3710	20.49 to 20.50 mm
		L4310	0.8067 to 0.8071 in.

## [2] POSITION CONTROL AND DRAFT CONTROL LINKAGE

### CHECKING AND ADJUSTING

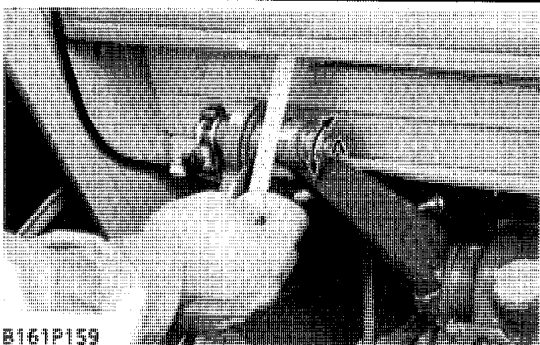
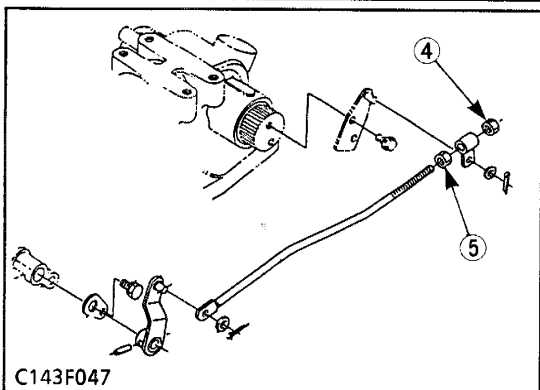
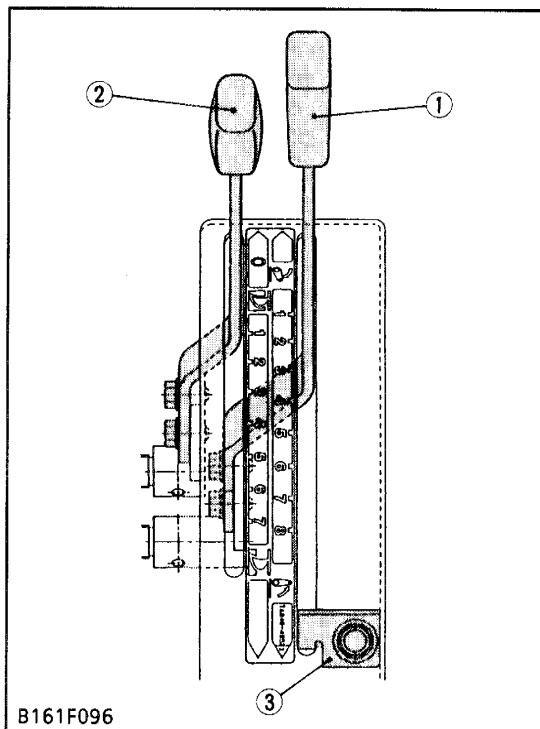

#### Adjusting Position Control Feedback Rod

1. Set the position control lever (1) to the lowest position.
2. Set the draft control lever (2) to the OFF position. (If equipped.)
3. Start the engine, and after warming-up, set the engine speed at the idling.
4. Move the position control lever (1) to the uppermost position. [Contact to the position control lever stopper (3).]
5. Turn the adjusting nut (4) and lock nut (5) together to counterclockwise until the relief valve begins to be operated.
6. From the relief valve operating position of nuts (4) and (5), turn back the adjusting nut (4) and lock nut (5) together to clockwise by 2 turn.
7. Tighten the lock nut (5).
8. Set the engine speed at the maximum.
9. Move the position control lever (1) to the lowest position and uppermost position (3 to 5 times) to check the relief valve does not operate.
10. Set the position control lever (1) to the uppermost position, then move the lift arm to the upper end by hand and measure the free play.
11. Stop the engine.
12. If the measurement is not within the factory specifications, adjusting position control feedback rod again.

Lift arm free play at maximum raising position	Factory spec.	5 to 10 mm 0.19 to 0.39 in.
--	---------------	--------------------------------

#### [A] Lift Arm Free Play

- |                                       |                   |
|---------------------------------------|-------------------|
| (1) Position Control Lever            | (4) Adjusting Nut |
| (2) Draft Control Lever (If Equipped) | (5) Lock Nut      |
| (3) Position Control Lever Stopper    |                   |

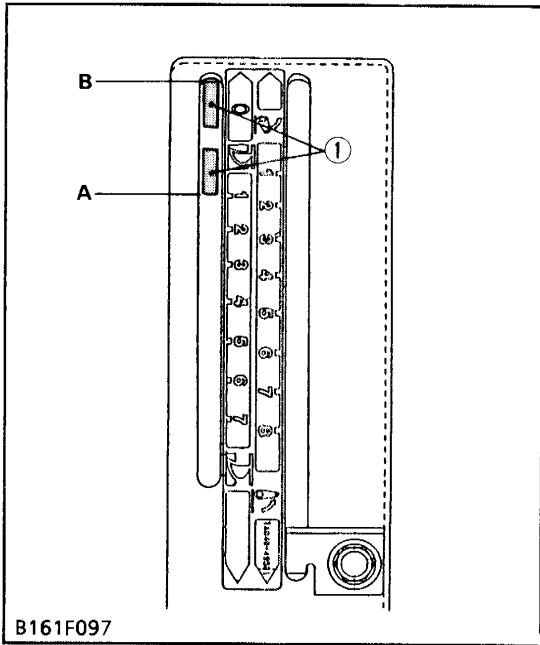

B161F097

**Adjusting Draft Control Rod (If Equipped)**

1. Set the draft control lever (1) to the **OFF** position.
2. Adjust the position control feedback rod. (Refer to "Adjusting Position Control Feedback Rod".)
3. Start the engine.
4. Move the position control lever and adjust so that the lower link is level.
5. Set the rear side (A) of the draft control lever (1) to the scale 1 of the lever guide. (Refer to the figure left.)
6. Set the engine speed at the maximum.
7. Attach the test bar (3) (see page G-34) to the top link bracket (2).
8. Pull the test bar (3) upward and adjust the draft control rod (6) so that the lower link is raised when the top link bracket (2) and the top link bracket holder (5) come in contact. (Confirm that the lower link is lowered when the test bar (3) is pushed downward.)
9. Confirm that the draft control will not operate (float) when the draft control lever (1) is set to **OFF** position (B).
10. After adjustment, tighten the lock nut firmly.

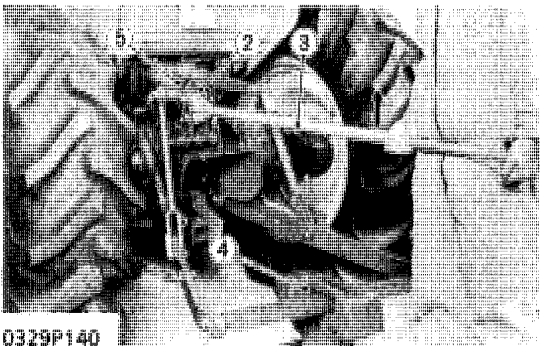

0329P140

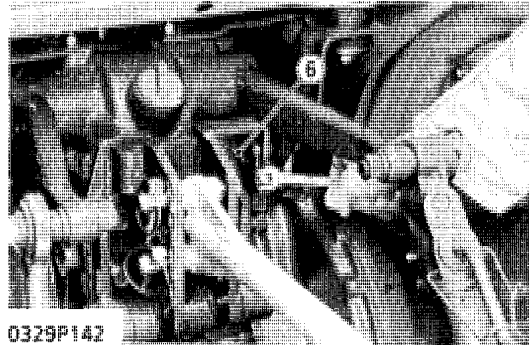

0329P142

- (1) Draft Control Lever
- (2) Top Link Bracket
- (3) Test Bar
- (4) Weight
- (5) Top Link Bracket Holder
- (6) Draft Control Rod

**DISASSEMBLING AND ASSEMBLING**

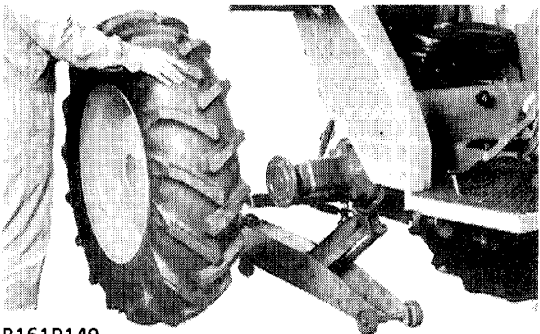

B161P149

**Rear Wheel**

1. Place a jack under the brake case.
2. Loosen and remove the rear wheel mounting screws and nuts.
3. Take out the rear wheel RH.

**(When reassembling)**

Tightening torque	Rear wheel mounting screws and nuts	197 to 226 N·m 20 to 23 kgf·m 145 to 166 ft·lbs
-------------------	-------------------------------------	---

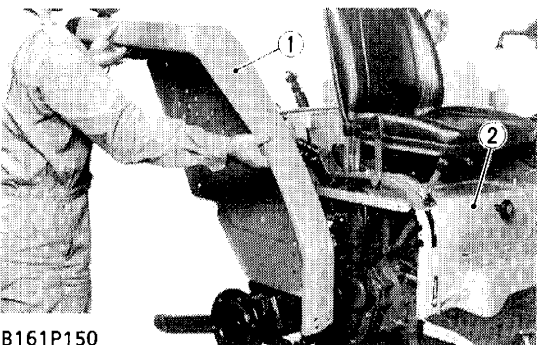

B161P150

**Fender and Seat Under Cover**

1. Disconnect the wire leads for hazard light and tail light.
2. Loosen and remove the fender mounting screws and nut.
3. Take out the fender RH (1).
4. Remove the seat under cover (2).

- (1) Fender RH
- (2) Seat Under Cover

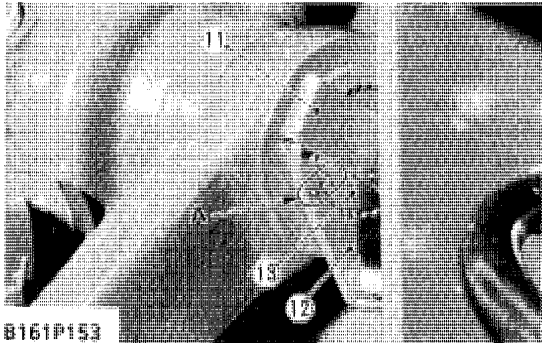
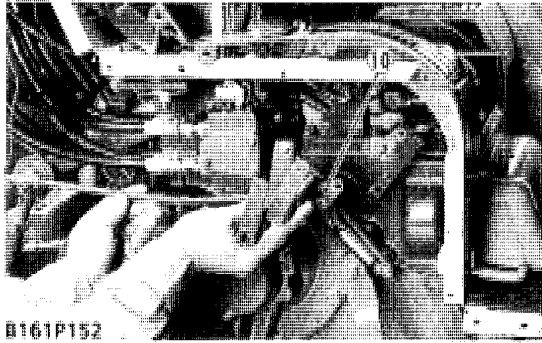
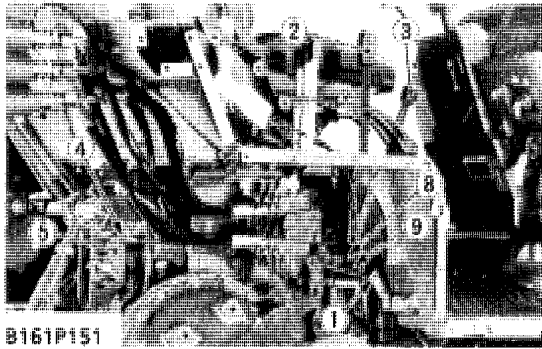

#### [A] Punched Marks

- |                                |                          |
|--------------------------------|--------------------------|
| (1) Differential Lock Rod      | (7) Draft Control Link 2 |
| (2) Position Control Lever     | (8) Control Rod          |
| (3) Draft Control Lever        | (9) Return Spring        |
| (4) Draft Control Rod          | (10) Linkage Assembly    |
| (5) Top Link Bracket           | (11) Stopper             |
| (6) Draft Control Feedback Rod | (12) Feedback Rod Stay   |
|                                | (13) Hydraulic Arm Shaft |

### Removing Position and Draft Control Linkage

1. Disconnect the differential lock rod (1) from differential lock pedal.
2. Disconnect the draft control rod (4) from the top link bracket (5).
3. Remove the position control lever (2) and draft control lever (3).
4. Disconnect the draft control feedback rod (6) from the draft control link 2 (7).
5. Remove the control rod (8) and return spring (9).
6. Remove the position and draft control linkage assembly mounting screws, and then take out the position and draft control linkage assembly (10).
7. Remove the draft control feedback rod stay stopper (11) and draft control feedback rod stay (12).

#### (When reassembling)

- Assemble so that the punch mark of the feedback rod stay (12) is set to the punch mark of the hydraulic arm shaft (13).
- Securely fit the rod stay stopper (11) into the groove of the hydraulic arm shaft (13).
- After reassembling, be sure to adjust the position control feedback rod and draft control rod (if equipped). (Refer to **CHECKING AND ADJUSTING**.)

Tightening torque	Control linkage assembly mounting screws	23.6 to 27.4 N·m 2.4 to 2.8 kgf·m 17.4 to 20.2 ft·lbs
-------------------	--	---

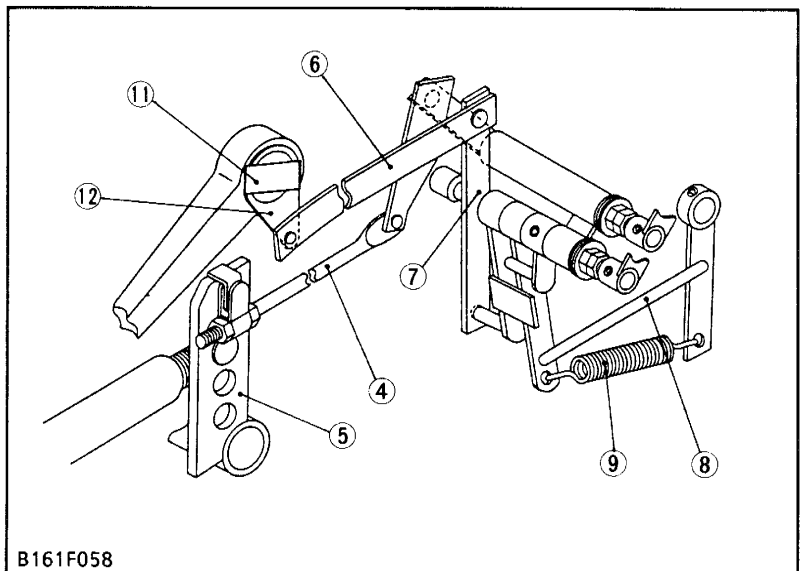

**Disassembling Position and Draft Control Linkage**

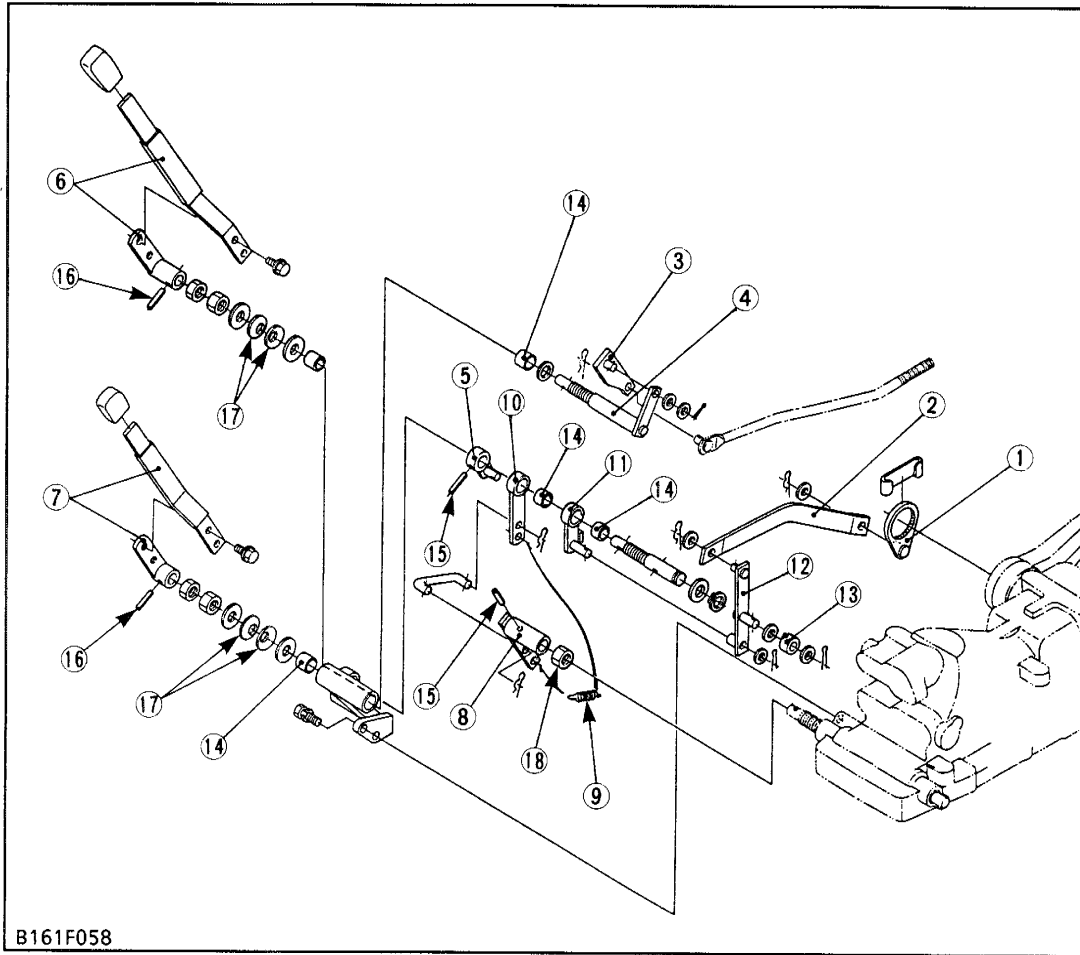

- (1) Feedback Rod Stay
- (2) Feedback Rod
- (3) Draft Cam
- (4) Draft Control Lever Shaft
- (5) Position Control Link
- (6) Position Control Lever
- (7) Draft Control Lever
- (8) Arm 2
- (9) Return Spring
- (10) Arm 1
- (11) Draft Control Link 1
- (12) Draft Control Link 2
- (13) Roller
- (14) Bushings
- (15) Spring Pins
- (16) Spring Pins
- (17) Disc Springs
- (18) Lock Nut

B161F058

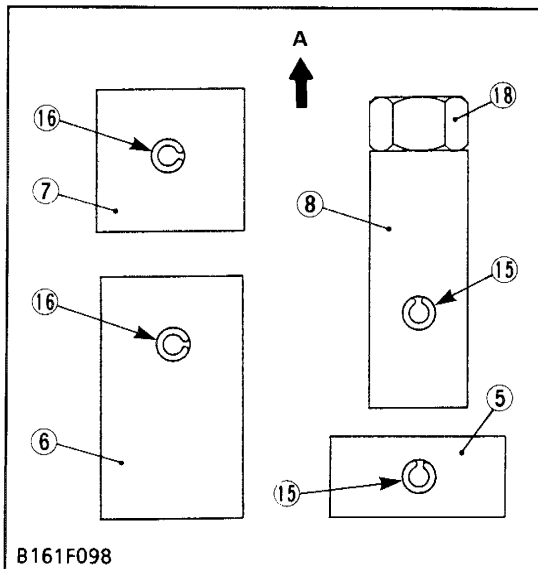

B161F098

■ It is possible to disassemble as shown in the figure above.

**(When reassembling)**

- Apply grease to the bushings (14), roller (13), draft control link 1 (11) and disc springs (17).
- Tap in the spring pins (15), (16) so that their split portion as shown in the figure left.
- Tighten the lock nut (18) to the arm 2 (8) side.

Tightening torque	Arm 2 lock nut	29.4 to 39.2 N·m 3.0 to 4.0 kgf·m 21.7 to 28.9 ft·lbs
-------------------	----------------	---

[A] Hydraulic Cylinder Block Side



### [3] RELIEF VALVE CHECKING AND ADJUSTING

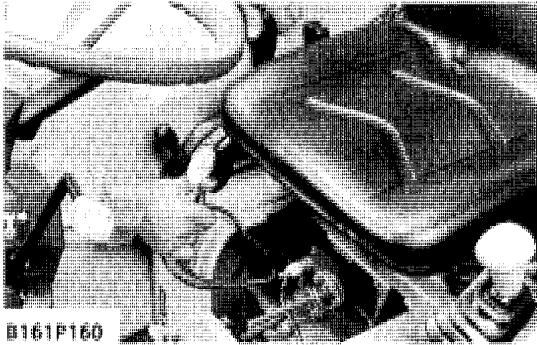

B161F160

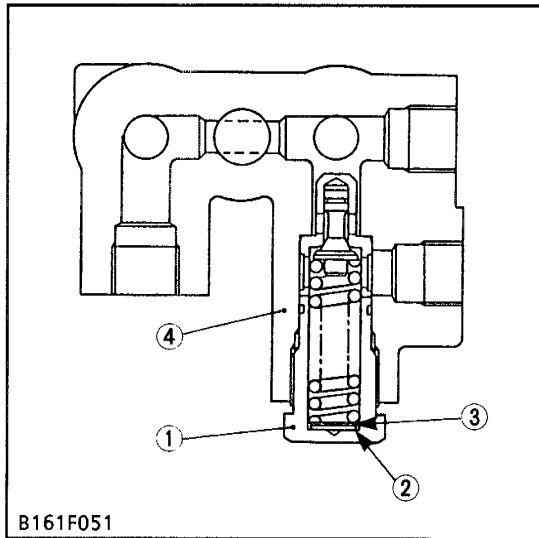

B161F051

- (1) Plug
- (2) Washer
- (3) Adjusting Shim
- (4) Front Hydraulic Block

#### Relief Valve Setting Pressure Test Using Pressure Tester

1. Remove the seat under cover.
2. Remove the plug (screw head size : 17 mm) from front of hydraulic cylinder block.
3. Install the adaptor 58 (screw size : PT 1/4). Then connect the cable and pressure gauge to adaptor 58.
4. Remove the position control lever stopper.
5. Start the engine and set at maximum speed.
6. Move the position control lever all way up to operate the relief valve and read the gauge.
7. If the pressure is not within the factory specifications, remove the plug (1) of front hydraulic block (4) and adjust with the adjusting shims (3).
8. After the relief valve setting pressure test, reset the position control lever stopper firmly.

Relief valve setting pressure	Factory spec.	16.2 to 17.2 MPa 165 to 175 kgf/cm <sup>2</sup> 2347 to 2489 psi
-------------------------------	---------------	--

#### Condition

- Engine speed ..... Maximum
- Oil temperature ..... 40 to 60 °C  
104 to 140 °F

#### (Reference)

- Thickness of shims (3) : 0.1 mm (0.0039 in.)  
0.2 mm (0.0078 in.)  
0.4 mm (0.0157 in.)
- Pressure change per  
0.1 mm (0.0039 in.) shim : Approx. 264.8 kPa  
2.7 kgf/cm<sup>2</sup>  
38.4 psi

### DISASSEMBLING AND ASSEMBLING

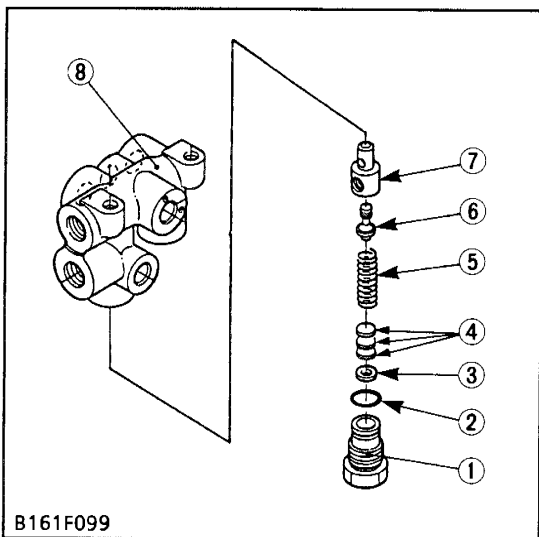

B161F099

- (1) Plug
- (2) O-ring
- (3) Washer
- (4) Adjusting Shims
- (5) Spring
- (6) Poppet
- (7) Valve Seat
- (8) Front Hydraulic Block

#### Relief Valve

1. Remove the plug (1), and draw out the spring (5) and the poppet (6).
2. Take out the valve seat (7).

#### (When reassembling)

- Take care not to damage the O-ring.

Tightening torque	Relief valve plug	49.0 to 68.6 N·m 5.0 to 7.0 kgf·m 36.2 to 50.6 ft·lbs
-------------------	-------------------	---

#### ■ IMPORTANT

- After disassembling and assembling the relief valve, be sure to adjust the relief valve setting pressure.

## [4] HYDRAULIC CYLINDER AND POSITION CONTROL VALVE

### DISASSEMBLING AND ASSEMBLING

#### (1) Removing Hydraulic Cylinder Assembly

**NOTE**

- If the tractors are cabin specifications, refer to section 10 CABIN [1] SEPARATING CABIN FROM TRACTOR BODY. (See page 10-S20.)

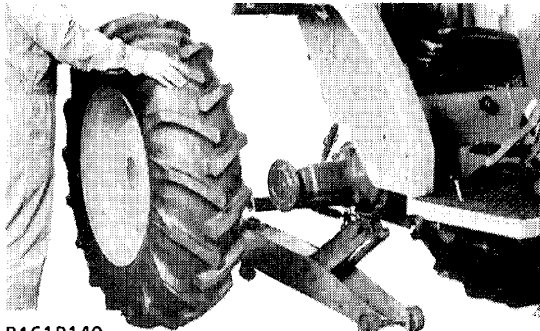

B161P149

#### ROPS and Rear Wheels

1. Remove the ROPS.
2. Place a jack under the brake case.
3. Loosen and remove the rear wheel mounting screws and nuts.
4. Take out the rear wheel.
5. The other side is same as above.

#### (When reassembling)

Tightening torque	ROPS mounting screws	M12, grade 7 screws	77.5 to 90.2 N·m 7.9 to 9.2 kgf·m 57.1 to 66.5 ft-lbs
		M14, grade 9 screws	166.7 to 196.1 N·m 17.0 to 20.0 kgf·m 123 to 144 ft-lbs
		M16, grade 11 screws	260.9 to 304.0 N·m 26.6 to 31.0 kgf·m 192 to 224 ft-lbs
		9/16-18 UNF, grade 8 screws	149.1 to 179.5 N·m 15.2 to 18.3 kgf·m 110 to 132 ft-lbs
		Rear wheel mounting stud bolts	98.1 to 112.7 N·m 10.0 to 11.5 kgf·m 72.3 to 83.1 ft-lbs
	Rear wheel mounting screws and nuts	197 to 226 N·m 20 to 23 kgf·m 145 to 166 ft-lbs	

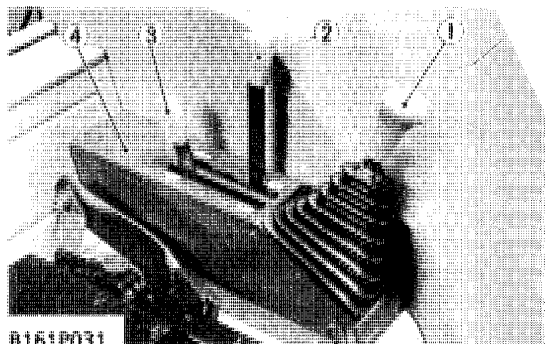

B161P031

#### Preparation 1

1. Remove the seat.
2. Loosen and remove the main gear shift (GST shift) lever grip (1).
3. Take out the Hi-Lo shift lever grip (2).
4. Take out the creep speed shift lever grip (3). (If equipped.)
5. Remove the shift lever guide (4).
6. Remove the GST shift cable (5). (GST type only.)
7. Disconnect the jumper leads for hazard light and tail light.

#### (When reassembling)

- Apply liquid gasket (Three Bond 1208D or equivalent) to the joint face between rotary valve cover and GST shift cable (5).
- GST shift lever to neutral position, then align the punched marks (A) of the rotary valve case and rotary valve shaft when install the GST shift cable (5). (GST type only.)

Tightening torque	GST shift cable mounting screws	7.8 to 8.8 N·m 0.8 to 0.9 kgf·m 5.8 to 6.5 ft-lbs
-------------------	---------------------------------	---

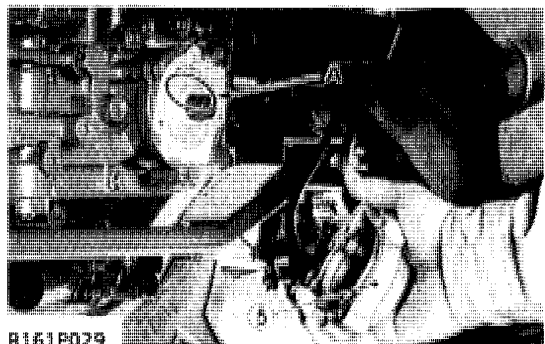

B161P029

#### [A] Punched Marks

- |  |                                     |
|--|-------------------------------------|
| (1) Main Gear Shift (GST Shift) Lever Grip     | (4) Shift Lever Guide               |
| (2) Hi-Lo Shift Lever Grip                     | (5) GST Shift Cable (GST Type Only) |
| (3) Creep Speed Shift Lever Grip (If Equipped) |                                     |

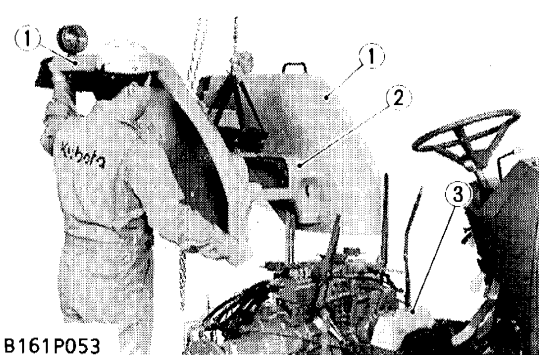
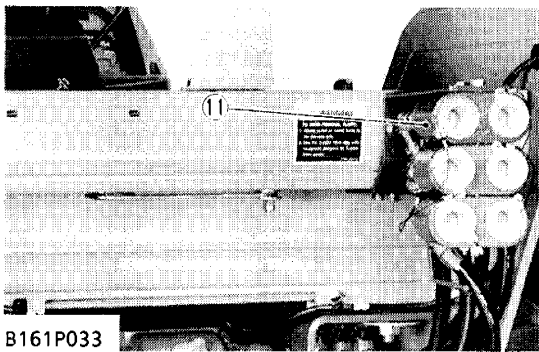
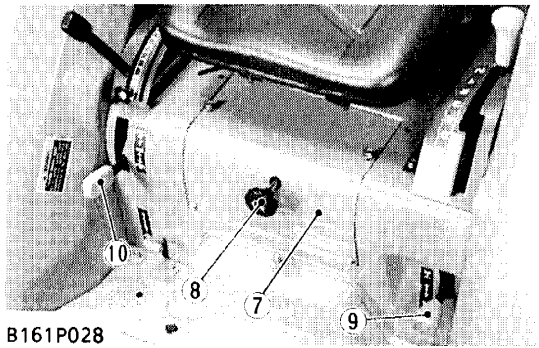
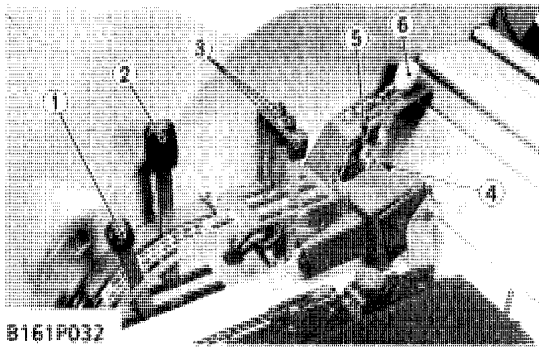

**Preparation 2**

1. Take out the position control lever grip (2).
2. Take out the draft control lever grip (1). (If equipped.)
3. Take out the auxiliary control lever grips (3). (If equipped.)
4. Disconnect the PTO shift cable (4) from the PTO shift lever (6).
5. Disconnect the PTO limit switch (5) leads.
6. Take out the lowering speed adjusting knob (8), and then remove the seat under cover (7).
7. Remove the mid PTO shift lever (10). (Mid PTO type only.)
8. Loosen and remove the front wheel drive shift lever grip (9). (4WD type only.)
9. Disconnect the jumper leads for hazard light and tail light.
10. Remove the quick coupler assembly (11). (If equipped.)

**(When reassembling)**

- Check and adjust the PTO shift cable. (See page 10-528.)

- |   |  |
|---|--|
| (1) Draft Control Lever Grip (If Equipped)      | (7) Seat Under Cover                                   |
| (2) Position Control Lever Grip                 | (8) Lowering Speed Adjusting Knob                      |
| (3) Auxiliary Control Lever Grips (If Equipped) | (9) Front Wheel Drive Shift Lever Grip (4WD Type Only) |
| (4) PTO Shift Cable                             | (10) Mid PTO Shift Lever (Mid PTO Type Only)           |
| (5) PTO Limit Switch                            | (11) Quick Coupler Assembly (If Equipped)              |
| (6) PTO Shift Lever                             |  |

**Fender and Floor Seat**

1. Loosen and remove the fenders and floor seat mounting screws to the platform (3).
2. Loosen and remove the floor seat mounting two bolts and nuts.
3. Support the floor seat with nylon lift strap and hoist.
4. Remove the fenders (1) and floor seat (2) as a unit.

**(When reassembling)**

Tightening torque	Floor seat mounting bolts and nuts	197 to 226 N·m 20 to 23 kgf·m 145 to 166 ft·lbs
-------------------	------------------------------------	---

- |                |              |
|----------------|--------------|
| (1) Fenders    | (3) Platform |
| (2) Floor Seat |              |

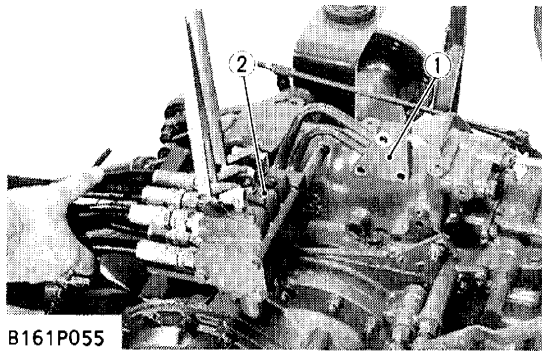

**Auxiliary Control Valves (If Equipped)**

1. Disconnect the draft control feedback rod. (If equipped.)
2. Loosen and remove the hydraulic pipe mounting three screws.
3. Loosen and remove the auxiliary control valves mounting two screws from floor seat support RH.
4. Take out the auxiliary control valves (2), hydraulic pipe (1) and quick couplers as a unit.

**(When reassembling)**

- Take care not to damage the O-rings.

(1) Hydraulic Pipe

(2) Auxiliary Control Valves

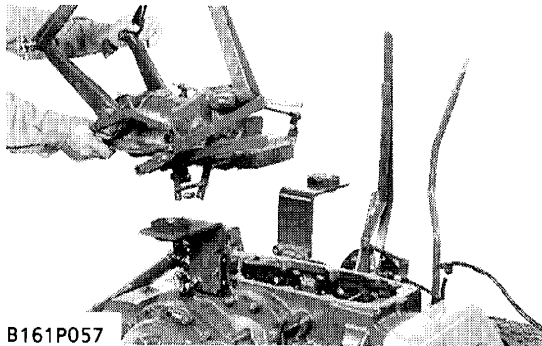

**Hydraulic Cylinder Assembly**

1. Disconnect the draft control rod from the top link bracket. (If equipped.)
2. Disconnect the lift rods from lift arms.
3. Remove the delivery pipe (from front hydraulic block to hydraulic cylinder assembly).
4. Loosen and remove the hydraulic cylinder assembly mounting screws and nuts.
5. Support the hydraulic cylinder assembly with nylon lift strap and hoist, and then take out it.

**(When reassembling)**

- Apply liquid gasket (Three Bond 1208D or equivalent) to joint face of the hydraulic cylinder assembly and transmission case after eliminate the water, oil and stuck liquid gasket.
- When replacing the hydraulic cylinder assembly mounting stud bolts, apply liquid lock (Three Bond 1372 or equivalent) to "A" portion of the stud bolt.

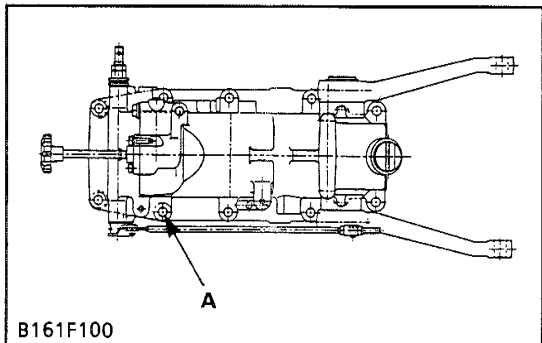

Tightening torque	Hydraulic cylinder assembly mounting stud bolts	34.3 to 49.0 N·m 3.5 to 5.0 kgf·m 25.3 to 36.2 ft-lbs
	Hydraulic cylinder assembly mounting screws and nuts	77.4 to 90.2 N·m 7.9 to 9.2 kgf·m 57.1 to 66.5 ft-lbs

**NOTE**

- Reassemble the hydraulic cylinder assembly to the tractor, be sure to adjust the position control feedback rod and draft control rod (If equipped). (See page 8-S9, S10.)

## (2) Disassembling Hydraulic Cylinder Assembly

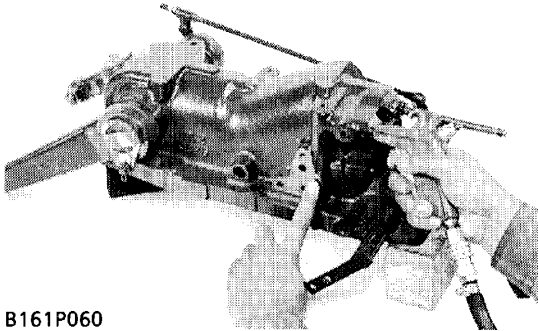

B161P060

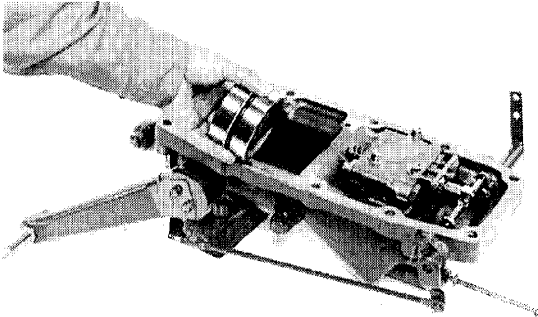

B161P061

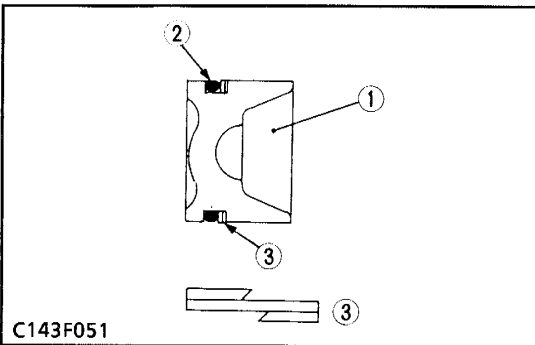

C143F051

### Hydraulic Rod and Hydraulic Piston

1. Tap out the spring pin.
2. Remove the hydraulic rod.
3. Remove the plug (screw head size : 17 mm) from front of hydraulic cylinder.
4. Inject the compressed air through the plug hole, and take out the hydraulic piston.

### **⚠ CAUTION**

- Do not put your hand into the hydraulic cylinder block because the hydraulic piston jumps out with a strong force, which is dangerous.

### **(When reassembling)**

- Install the piston, noting O-ring (2) and back-up ring (3). (See figure.)
- Apply transmission fluid to the cylinder, and then install the piston.
- Apply grease to the piston bottom contacts with hydraulic rod.

- (1) Piston  
(2) O-ring

- (3) Back-up Ring

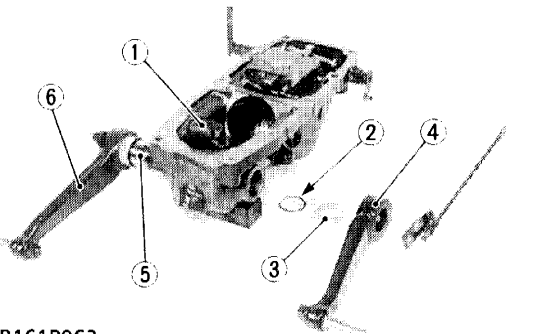

B161P062

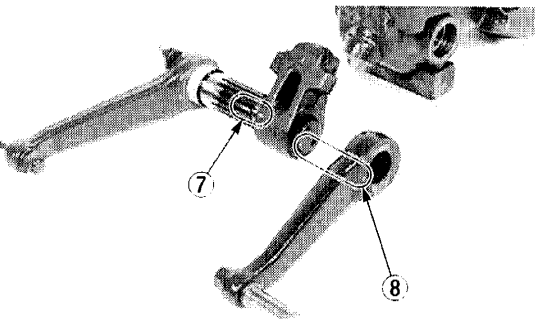

B161P063

### Lift Arm, Hydraulic Arm and Hydraulic Arm Shaft

1. Disconnect the feedback rod from feedback lever.
2. Remove the lift arm setting screws.
3. Remove the lift arm LH (4).
4. Draw out the hydraulic arm shaft (5) and lift arm RH (6) as a unit.
5. Take out the hydraulic arm (1).
6. Remove the collar (3) and O-ring (2).

### **(When reassembling)**

- Align the alignment marks (7) of the hydraulic arm (1) and hydraulic arm shaft (5).
- Align the alignment marks (8) of the lift arms (6), (4) and hydraulic arm shaft (5).
- Apply grease to the right and left bushings of hydraulic cylinder block and O-rings (2).
- Take care not to damage the O-rings (2).

- (1) Hydraulic Arm  
(2) O-rings  
(3) Collars  
(4) Lift Arm LH  
(5) Hydraulic Arm Shaft  
(6) Lift Arm RH  
(7) Alignment Mark  
(Hydraulic Arm Shaft and Hydraulic Arm)  
(8) Alignment Mark  
(Hydraulic Arm Shaft and Lift Arm)

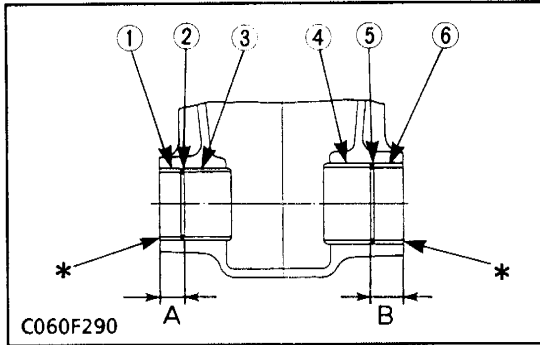

- (1) Collar (Left)
- (2) O-ring
- (3) Bushing (Left)
- (4) Bushing (Right)
- (5) O-ring
- (6) Collar (Right)

\* Flush the end of collar with the end of hydraulic cylinder body.

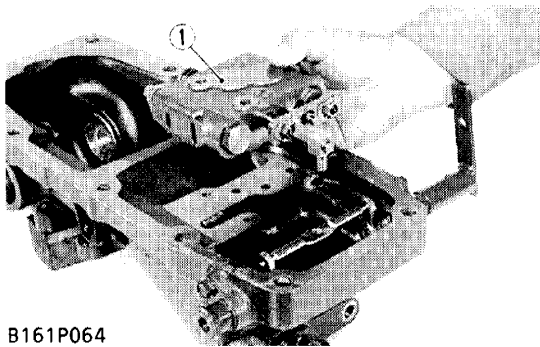

**Bushings**

1. Remove the bushings (3) and (4).

**(When reassembling)**

- When press-fitting new bushings (3), (4) with a press-fitting tool (see page G-34) observe the dimensions described in the figure.
- Apply transmission fluid to the hydraulic cylinder boss and bushing.
- Press-fit the bushing so that each seam face upward.

Press-fit location of bushings	Factory spec.	A (Left side)	20.0 to 21.0 mm 0.79 to 0.83 in.
		B (Right side)	18.0 to 19.0 mm 0.71 to 0.75 in.

**Position Control Valve**

1. Loosen and remove the position control valve mounting screws.
2. Take out the position control valve (1).

**(When reassembling)**

- Take care not to damage the O-rings.

Tightening torque	Position control valve mounting screws	23.6 to 27.4 N·m 2.4 to 2.8 kgf·m 17.4 to 20.2 ft-lbs
-------------------	--	---

- (1) Position Control Valve

**Disassembling Position Control Valve**

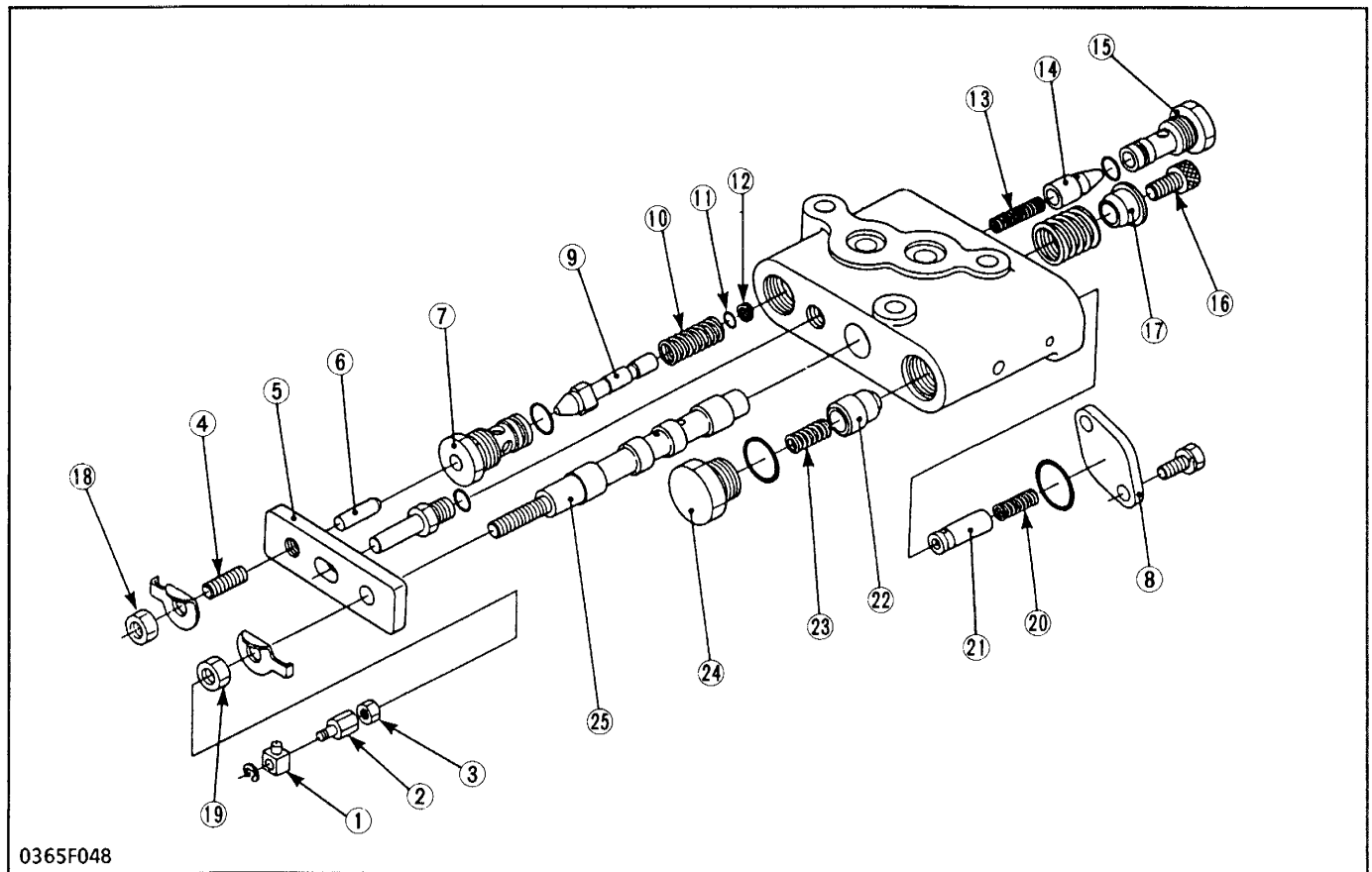

0365F048

- |                   |                   |                    |                    |
|-------------------|-------------------|--------------------|--------------------|
| (1) Spool Joint 2 | (8) Plate 2       | (14) Poppet 1      | (20) Spring        |
| (2) Spool Joint 1 | (9) Poppet 2      | (15) Plug 1        | (21) Poppet 3      |
| (3) Lock Nut      | (10) Spring 2     | (16) Screw         | (22) Unload Poppet |
| (4) Set Screw     | (11) O-ring       | (17) Spring Holder | (23) Spring        |
| (5) Plate 1       | (12) Back-up Ring | (18) Nut 1         | (24) Unload Plug   |
| (6) Push Rod      | (13) Spring       | (19) Nut 2         | (25) Spool         |
| (7) Plug 2        |                   |                    |                    |

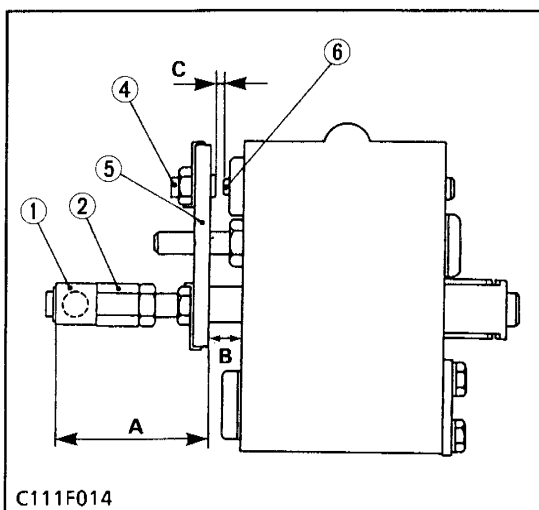

C111F014

■ It is possible to disassemble as shown in the figure above.

■ **IMPORTANT**

- Set screw (4) and spool joint 1 (2) are adjusted to very close accuracy. Do not disassemble them or cause them to be out of order unless necessary. If disassembled due to unavoidable reasons, be sure to make the following adjustments before assembling.

■ **Dimensions for assembling spool joint 1 (2)**

1. Turn and adjust the spool joint 1 (2) so that the dimension (A) between the spool joint 2 (1) and the plate 1 (5) is 47.5 mm (1.87 in.).
2. After the adjustment, be sure to adjust the position control feedback rod.

■ **Dimensions for assembling set screw (4)**

1. Set the dimension (B) between the plate 1 (5) and the valve body to 16.0 mm (0.63 in.).
2. Turn and adjust the set screw (4) so that the clearance (C) between the set screw (4) and the push rod (6) is 0.1 to 0.2 mm (0.0039 to 0.0079 in.).

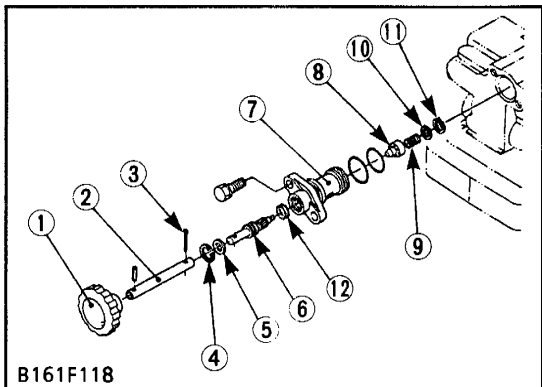

B161F118

**Lowering Speed Adjusting Valve**

1. Remove the lowering speed adjusting valve assembly from hydraulic cylinder block.
2. Remove the internal snap ring (4), and remove the hydraulic adjusting shaft (6).
3. Remove the internal snap ring (11), and draw out the spring (9) and adjusting collar (8).

**(When reassembling)**

- Install the hydraulic adjusting shaft (6) to valve body (7), noting O-rings (12).

- |                               |                         |
|-------------------------------|-------------------------|
| (1) Grip                      | (7) Valve Body          |
| (2) Extension Shaft           | (8) Adjusting Collar    |
| (3) Cotter Pin                | (9) Spring              |
| (4) Internal Snap Ring        | (10) Washer             |
| (5) Washer                    | (11) Internal Snap Ring |
| (6) Hydraulic Adjusting Shaft | (12) O-rings            |

**SERVICING**

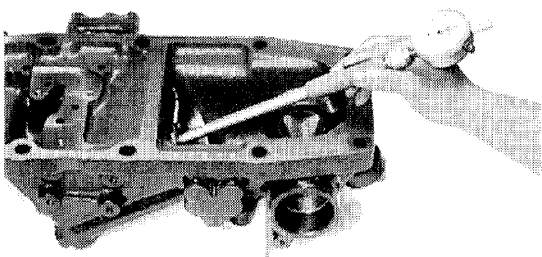

C060P238

**Hydraulic Cylinder Bore**

1. Check the cylinder internal surface for scoring or damage.
2. Measure the cylinder I.D. with a cylinder gauge.
3. If the measurement exceeds the allowable limit, replace the hydraulic cylinder block.

Cylinder I.D.	Factory spec.	90.000 to 90.050 mm 3.54330 to 3.54527 in.
	Allowable limit	90.150 mm 3.54921 in.

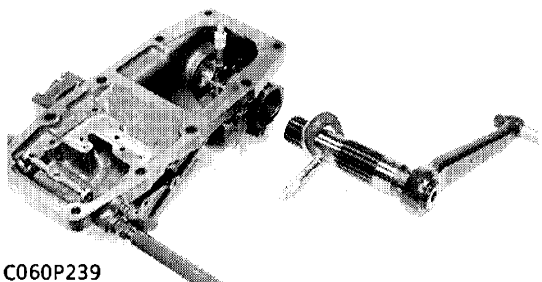

C060P239

**Clearance between Hydraulic Arm Shaft and Bushing**

1. Measure the hydraulic arm shaft O.D. with an outside micrometer.
2. Measure the bushing I.D. with an inside micrometer, and calculate the clearance.
3. If the clearance exceeds the allowable limit, replace the bushing.

Clearance between hydraulic arm shaft and bushing	Right	Factory spec.	0.125 to 0.230 mm 0.00492 to 0.00906 in.
		Allowable limit	0.50 mm 0.0197 in.
	Left	Factory spec.	0.125 to 0.220 mm 0.00492 to 0.00866 in.
		Allowable limit	0.50 mm 0.0197 in.
Hydraulic arm shaft O.D.	Right	Factory spec.	44.920 to 44.950 mm 1.76850 to 1.76968 in.
	Left	Factory spec.	39.920 to 39.950 mm 1.57165 to 1.57283 in.
Bushing I.D. (after press fitted)	Right	Factory spec.	45.075 to 45.150 mm 1.77460 to 1.77756 in.
	Left	Factory spec.	40.075 to 40.140 mm 1.57775 to 1.58031 in.



# MECHANISM

## CONTENTS

[1]	WIRING DIAGRAM .....	9-M1
[2]	ELECTRICAL CIRCUIT .....	9-M2
[3]	STARTING SYSTEM .....	9-M3
	(1) Starter Motor .....	9-M4
	(1)-1 Roller Clutch .....	9-M4
	(1)-2 Magnet Switch .....	9-M5
	(1)-3 Operation of Starter Motor.....	9-M5
	(2) Glow Control System .....	9-M6
[4]	ENGINE KEY SWITCH SHUT-OFF SYSTEM .....	9-M10
	(1) Operation of Timer Relay .....	9-M11
	(2) Fuel Cut Off Solenoid .....	9-M12
[5]	CHARGING SYSTEM .....	9-M12
	(1) Alternator .....	9-M13
	(2) IC Regulator .....	9-M13
	(3) Operation of Charging System .....	9-M14
[6]	LIGHTING SYSTEM .....	9-M15
	(1) Head Light .....	9-M16
	(2) Hazard Light .....	9-M16
[7]	EASY CHECKER .....	9-M18
	(1) Indication Items .....	9-M18
	(2) Engine Oil Pressure Alarm .....	9-M18
	(3) Air Cleaner Clogged Lamp .....	9-M19
[8]	GAUGES .....	9-M20
	(1) Sensor .....	9-M20
	(2) Gauge .....	9-M21



[1] WIRING DIAGRAM

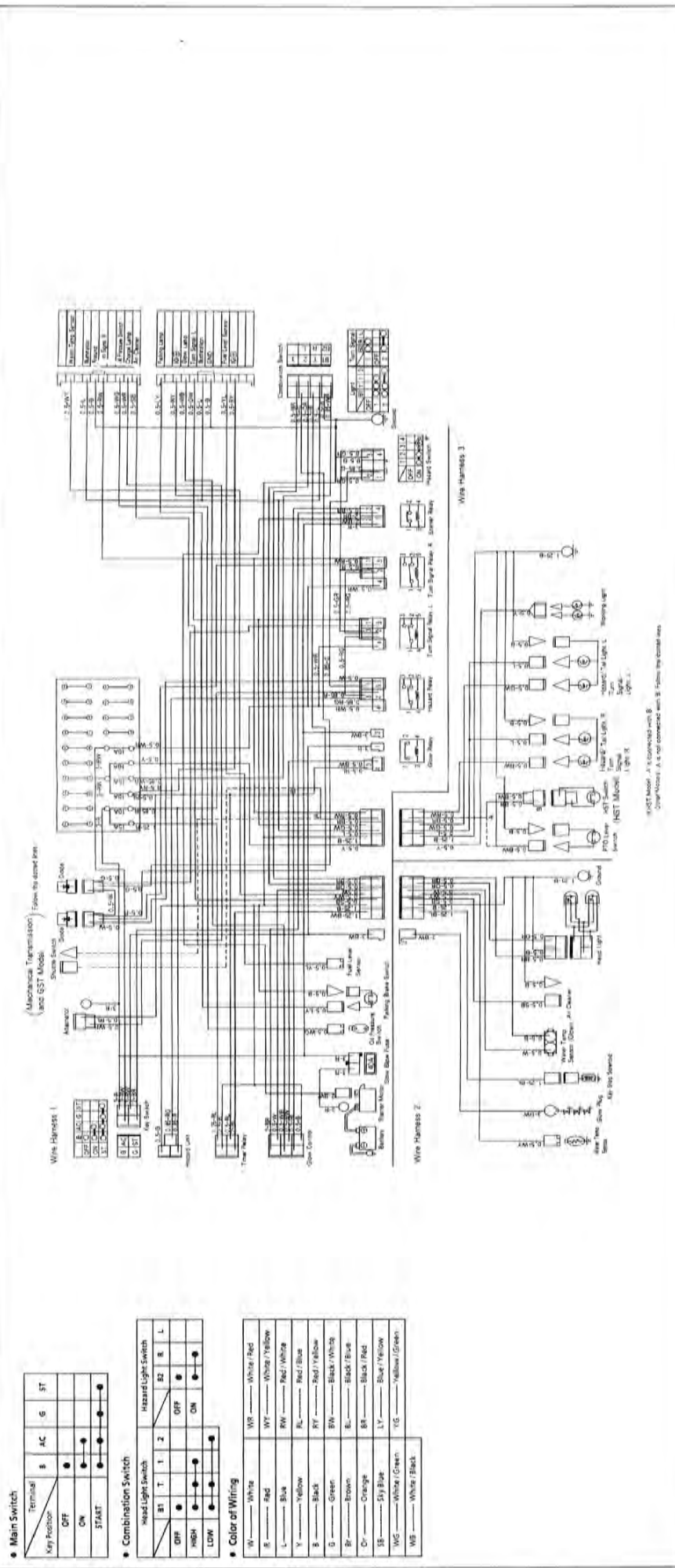

# [1] WIRING DIAGRAM

## ● Main Switch

Terminal	B	AC	G	ST
Key Position				
OFF	●			
ON	●	●		
START	●	●	●	●

## ● Combination Switch

Head Light Switch				Hazard Light Switch			
Terminal	B1	T	1	2	B2	R	L
OFF	●				●		
HIGH	●	●	●	●	●	●	
LOW	●	●	●	●	●		●

## ● Color of Wiring

W ----- White	WR ----- White / Red
R ----- Red	WY ----- White / Yellow
L ----- Blue	RW ----- Red / White
Y ----- Yellow	RL ----- Red / Blue
B ----- Black	RY ----- Red / Yellow
G ----- Green	BW ----- Black / White
Br ----- Brown	BL ----- Black / Blue
Or ----- Orange	BR ----- Black / Red
SB ----- Sky Blue	LY ----- Blue / Yellow
WG ----- White / Green	YG ----- Yellow / Green
WB ----- White / Black	

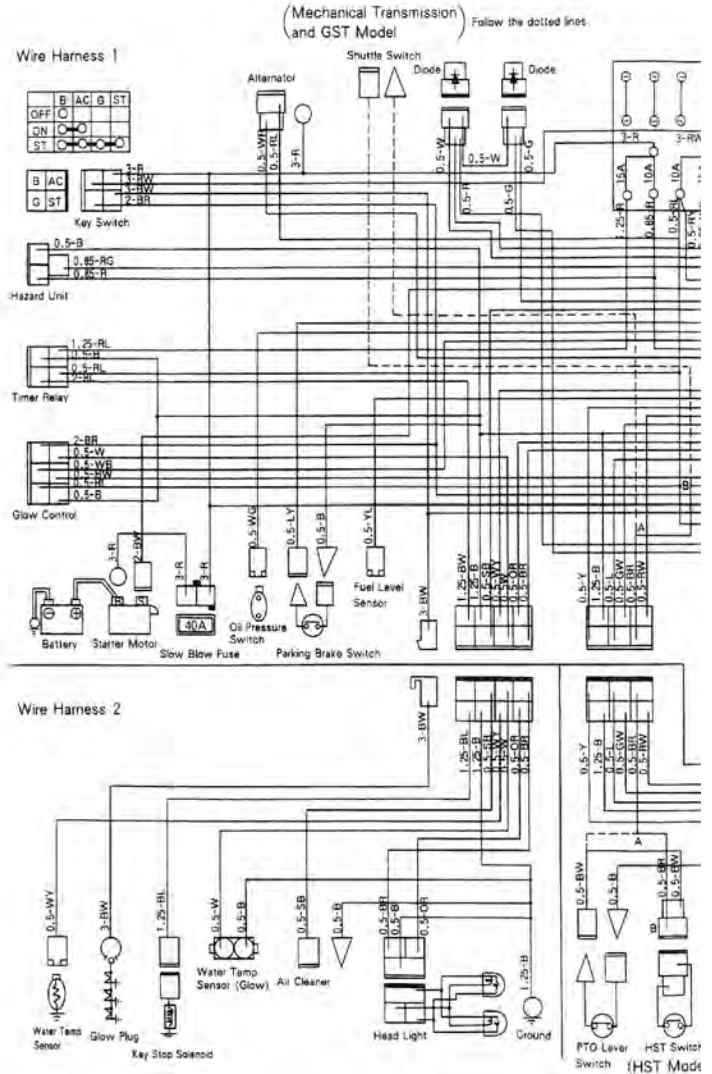

■ HST Mod  
 Other Mo

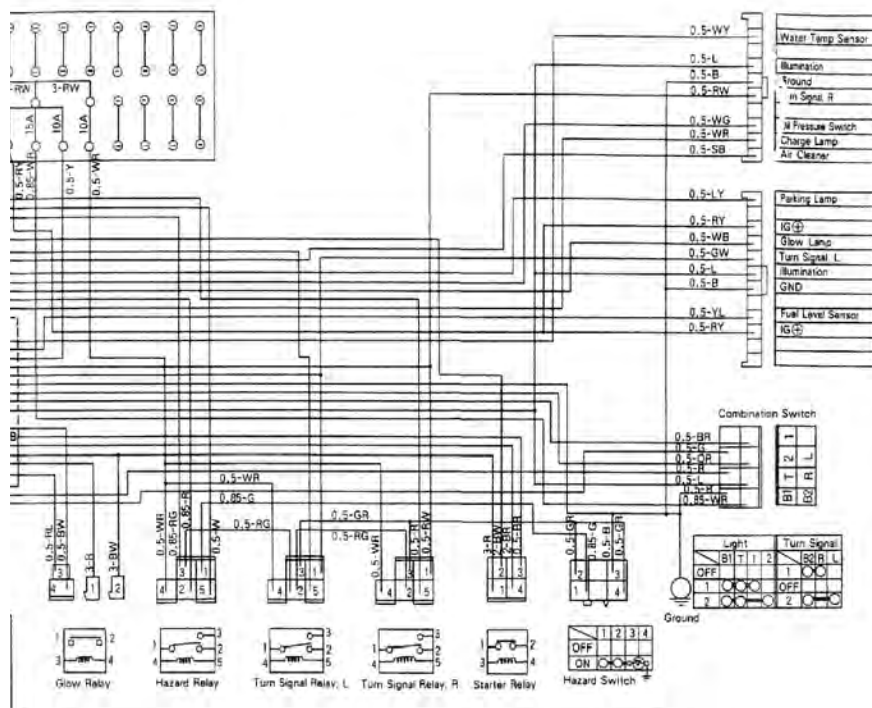

Wire Harness 3

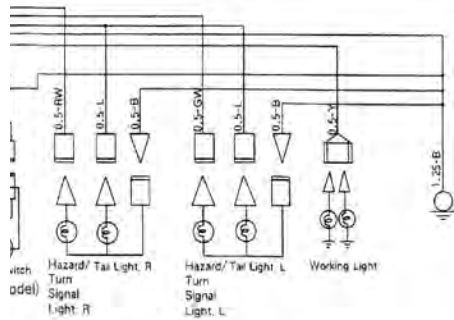

Model: A is connected with B  
 Model: A is not connected with B. Follow the dotted lines.



12] ELECTRICAL CIRCUIT

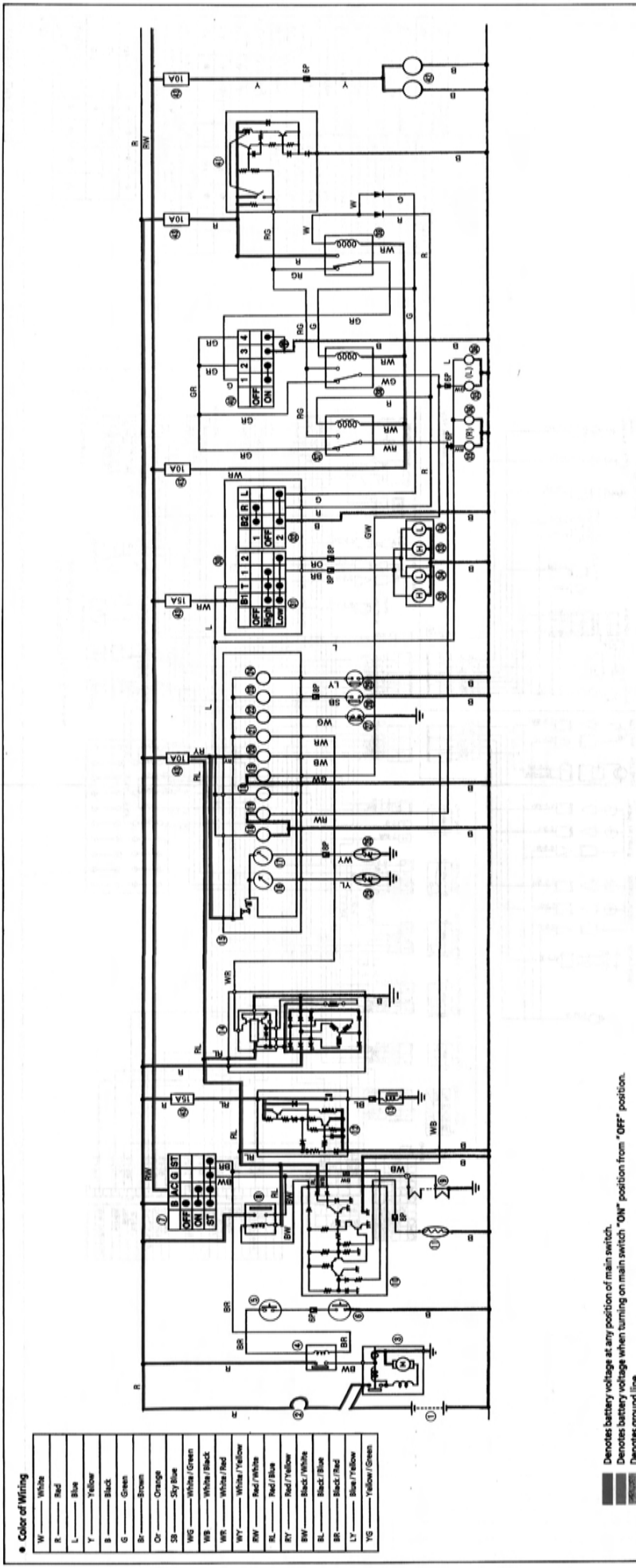

- 1) Battery
- 2) Glow Plug Fuse
- 3) Hazard Signal Relay (A)
- 4) Starter Relay
- 5) Shunt Limit Switch or HST Switch
- 6) Glow Plug
- 7) Glow Controller
- 8) Fuel Cut-Off Solenoid
- 9) Meter Panel
- 10) Water Panel
- 11) Key Stop Timer Relay
- 12) Fuel Gauge
- 13) Constant Temperature Gauge
- 14) Coolant Temperature Gauge
- 15) Hazard Indicator
- 16) Hazard Indicator
- 17) Hazard Indicator
- 18) Hazard Indicator
- 19) Hazard Indicator
- 20) Glow Lamp
- 21) Glow Lamp
- 22) Glow Lamp
- 23) Air Cleaner Clogged Lamp
- 24) Parking Brake Lamp
- 25) Fuel Level Sensor
- 26) Fuel Level Sensor
- 27) Engine Oil Pressure Sensor
- 28) Air Cleaner Sensor
- 29) Parking Brake Switch
- 30) Light Switch
- 31) Light Switch
- 32) Hazard Switch
- 33) Hazard Light
- 34) Hazard Light
- 35) Hazard Light
- 36) Hazard Light
- 37) Hazard Light
- 38) Turn Signal Relay (A)
- 39) Turn Signal Relay (B)
- 40) Turn Signal Relay (C)
- 41) Hazard Unit
- 42) Parking Light
- 43) Parking Light
- 44) Parking Light
- 45) Parking Light
- 46) Parking Light
- 47) Parking Light
- 48) Parking Light
- 49) Parking Light
- 50) Parking Light
- 51) Parking Light
- 52) Parking Light
- 53) Parking Light
- 54) Parking Light
- 55) Parking Light
- 56) Parking Light
- 57) Parking Light
- 58) Parking Light
- 59) Parking Light
- 60) Parking Light
- 61) Parking Light
- 62) Parking Light
- 63) Parking Light
- 64) Parking Light
- 65) Parking Light
- 66) Parking Light
- 67) Parking Light
- 68) Parking Light
- 69) Parking Light
- 70) Parking Light
- 71) Parking Light
- 72) Parking Light
- 73) Parking Light
- 74) Parking Light
- 75) Parking Light
- 76) Parking Light
- 77) Parking Light
- 78) Parking Light
- 79) Parking Light
- 80) Parking Light
- 81) Parking Light
- 82) Parking Light
- 83) Parking Light
- 84) Parking Light
- 85) Parking Light
- 86) Parking Light
- 87) Parking Light
- 88) Parking Light
- 89) Parking Light
- 90) Parking Light
- 91) Parking Light
- 92) Parking Light
- 93) Parking Light
- 94) Parking Light
- 95) Parking Light
- 96) Parking Light
- 97) Parking Light
- 98) Parking Light
- 99) Parking Light
- 100) Parking Light

[2] ELECTRICAL CIRCUIT

● Color of Wiring

W	White
R	Red
L	Blue
Y	Yellow
B	Black
G	Green
Br	Brown
Or	Orange
SB	Sky Blue
WG	White / Green
WB	White / Black
WR	White / Red
WY	White / Yellow
RW	Red / White
RL	Red / Blue
RY	Red / Yellow
BW	Black / White
BL	Black / Blue
BR	Black / Red
LY	Blue / Yellow
YG	Yellow / Green

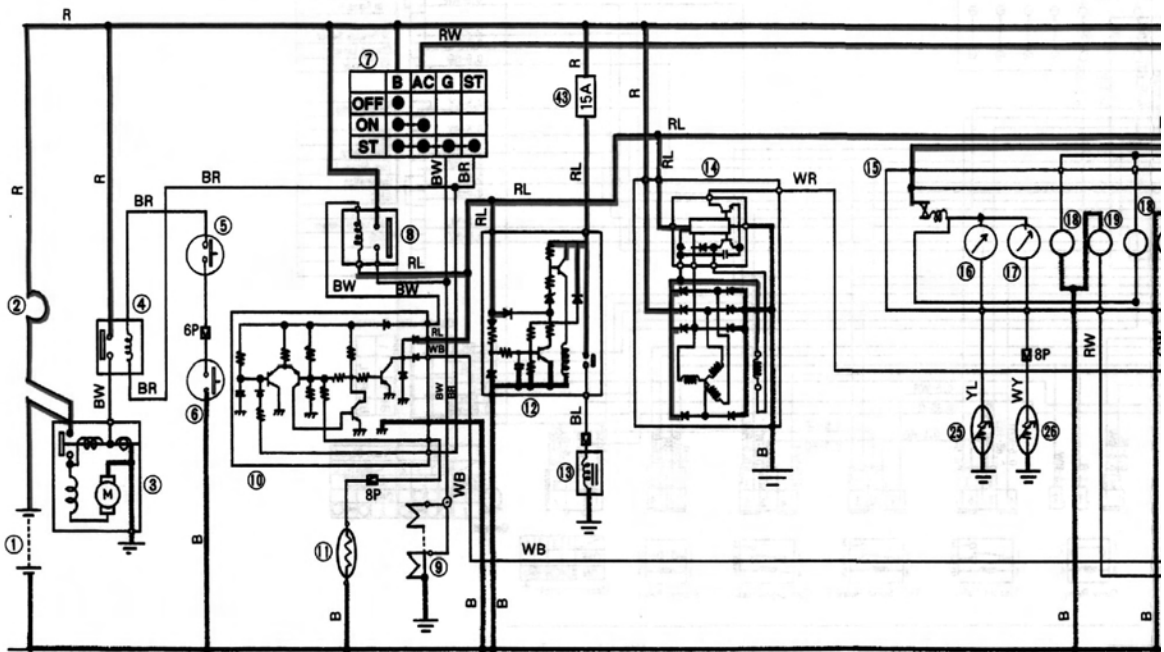

Denotes battery voltage at any position of main switch.  
 Denotes battery voltage when turning on main switch "ON" position from "OFF" position.  
 Denotes ground line.

12190F90020

- |                    |  |  |                            |                                |                               |
|--------------------|--|--|----------------------------|--------------------------------|-------------------------------|
| (1) Battery        | (5) Shuttle Limit Switch or HST Switch | (9) Glow Plug  | (12) Key Stop Timer Relay  | (16) Fuel Gauge                | (20) Glow Lamp                |
| (2) Slow Blow Fuse | (6) PTO Limit Switch                   | (10) Glow Controller                                     | (13) Fuel Cut Off Solenoid | (17) Coolant Temperature Gauge | (21) Charge Lamp              |
| (3) Starter Motor  | (7) Main Switch                        | (11) Water Temperature Sensor<br>(For Preheating System) | (14) Alternator            | (18) Illumination              | (22) Engine Oil Pressure Lamp |
| (4) Starter Relay  | (8) Glow Relay                         |  | (15) Meter Panel           | (19) Hazard Indicator          | (23) Air Cleaner Clogged Lamp |



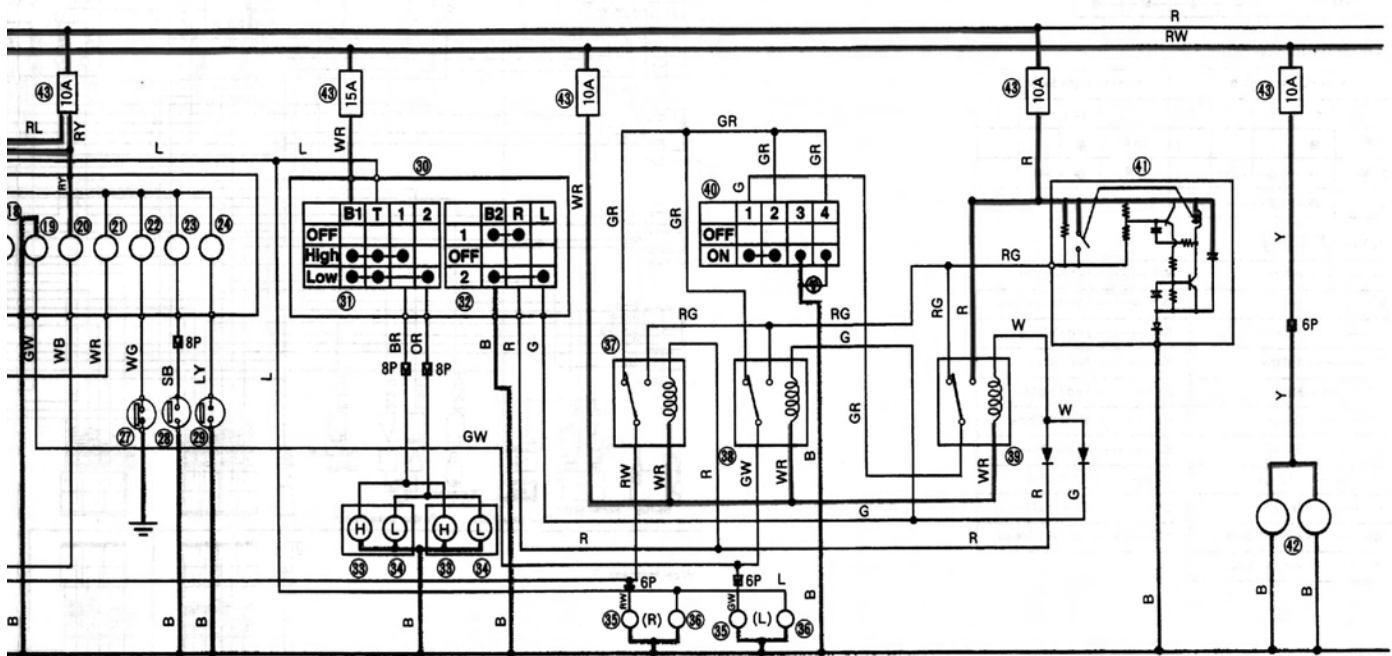

- |                                 |                           |                           |                            |                            |                    |
|---------------------------------|---------------------------|---------------------------|----------------------------|----------------------------|--------------------|
| (24) Parking Brake Lamp         | (28) Air Cleaner Sensor   | (32) Hazard Switch        | (35) Hazard Light          | (38) Turn Signal Relay (L) | (41) Hazard Unit   |
| (25) Fuel Level Sensor          | (29) Parking Brake Switch | (33) Head Light (Hi-beam) | (36) Tail Light            | (39) Hazard Relay          | (42) Working Light |
| (26) Coolant Temperature Sensor | (30) Combination Switch   | (34) Head Light (Lo-beam) | (37) Turn Signal Relay (R) | (40) Hazard Switch         | (43) Fuse          |
| (27) Engine Oil Pressure Switch | (31) Light Switch         |                           |                            |                            |                    |

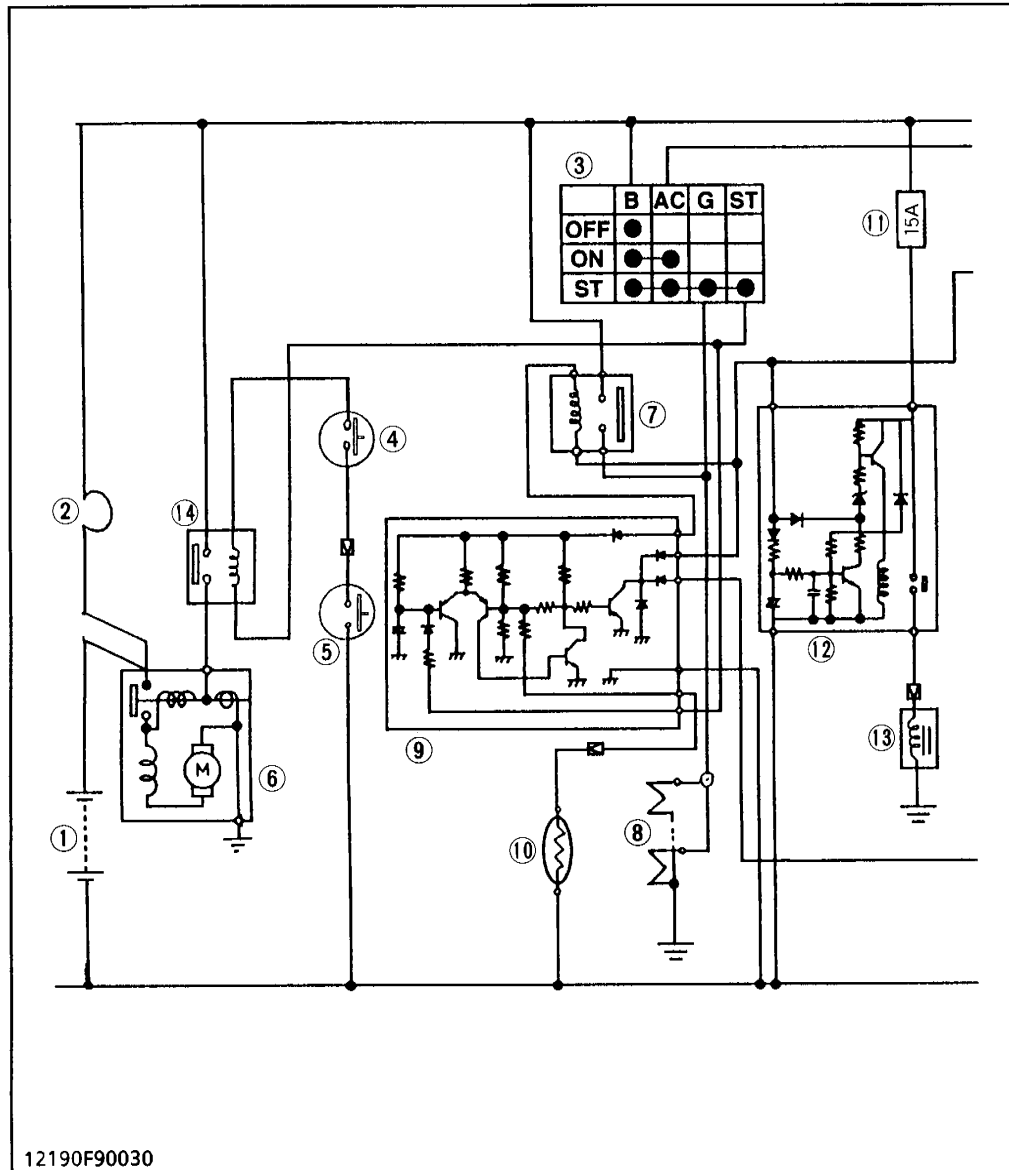

**[3] STARTING SYSTEM**

- (1) Battery
- (2) Slow Blow Fuse
- (3) Main Switch
- (4) Shuttle Limit Switch or HST Switch
- (5) PTO Limit Switch
- (6) Starter Motor
- (7) Glow Relay
- (8) Glow Plug
- (9) Glow Controller
- (10) Water Temperature Sensor (for Preheating System)
- (11) Fuse
- (12) Timer Relay
- (13) Key Stop Solenoid
- (14) Starter Relay

12190F90030

When the main switch (3) is turned to the **ON** position, the terminal **B** is connected to the terminal **AC** then magnetizes the coil of glow relay (7).

The glow relay (7) is turned **ON**, the glow plugs (8) become red hot, and at the same time, light up the glow lamp on the meter panel.

When the main switch (3) is turned to the **START** position with the shuttle limit switch (4) (Mechanical transmission and GST Mode), HST switch (HST Model) and PTO limit switch (5) **ON**, after the glow lamp is put out light.

The terminal **B** is connected to the terminal **AC**, **ST** and **G** so that the starter motor (6) begins running and the glow plugs (8) are kept red hot.

The main switch (3) automatically returns to the **ON** position when it is released after the engine starts.

At the **ON** position, the starting circuit to be opened, stopping the starter motor (6).

**(1) Starter Motor**

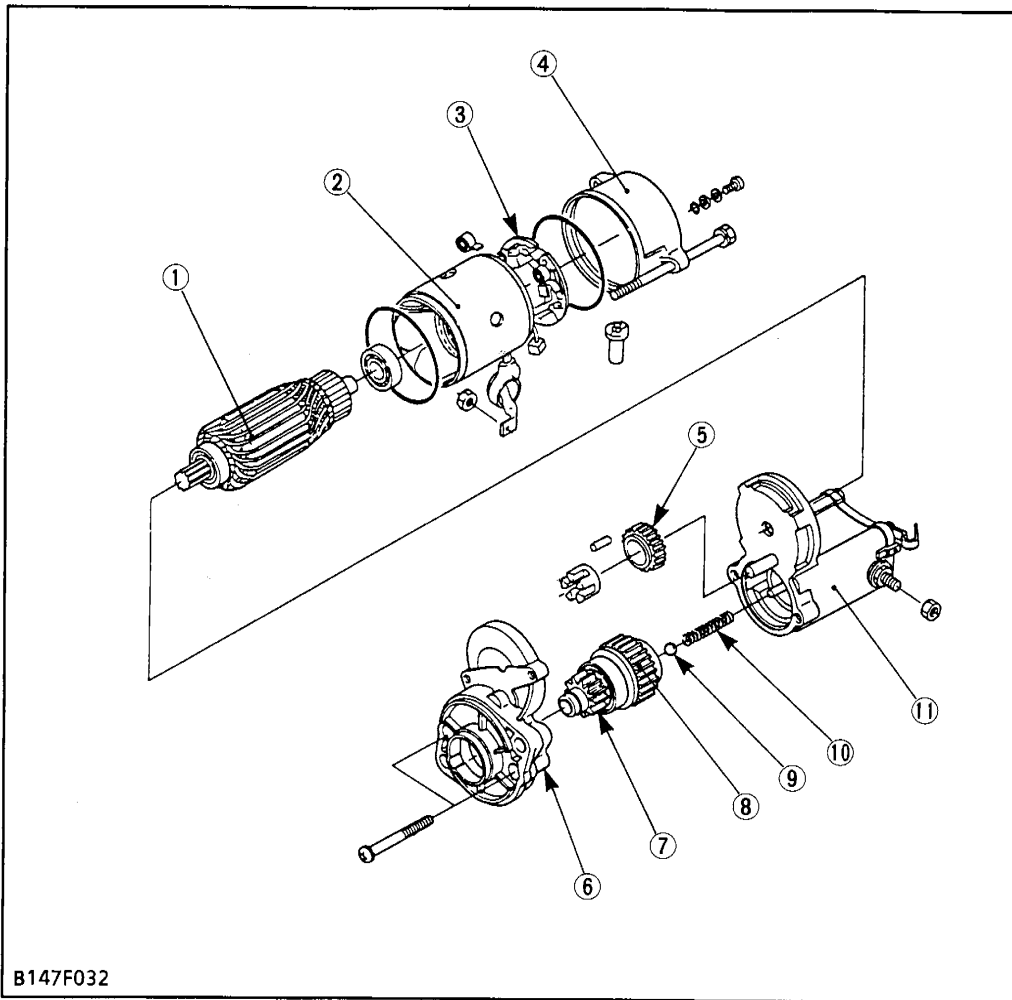

- (1) Armature
- (2) Yoke
- (3) Brush Holder
- (4) End Frame
- (5) Gear
- (6) Drive End Frame
- (7) Pinion
- (8) Roller Clutch
- (9) Ball
- (10) Spring
- (11) Magnet Switch

B147F032

The starter motor is a reduction type.  
The speed of the pinion gear is reduced to approx.

one third of motor one.

**(1)-1 Roller Clutch**

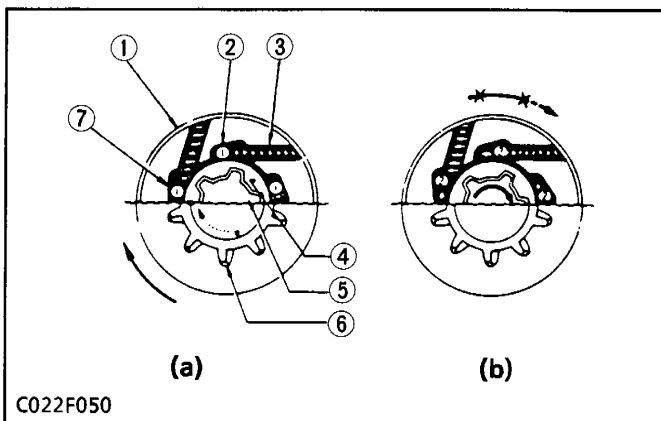

C022F050

- (a) When power is transmitted
- (b) Idling rotation with pinion shaft speed exceeding that of outer clutch gear

The roller clutch prevents the armature from being driven by the rotational force of the engine when the pinion and the engine flywheel ring gear are in mesh.

- (a) When power is transmitted, the rotational force of the outer clutch gear (1) drives the pinion gear (6) through the roller (2).
- (b) Even when the pinion gear is driven by the engine flywheel ring gear and its speed exceeds that of the outer clutch gear, the rotation force of the ring gear is not transmitted to the outer clutch gear.

- (1) Outer Clutch Gear
- (2) Roller
- (3) Roller Spring
- (4) Inner Spline Tube
- (5) Pinion Shaft, Solid with Pinion Gear
- (6) Pinion Gear
- (7) Locked Position

**(1)-2 Magnet Switch**

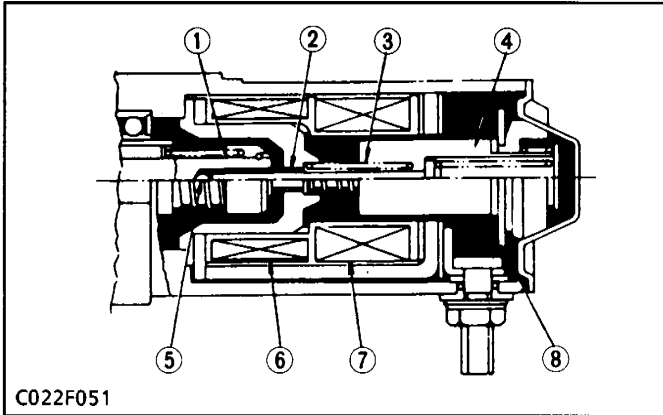

- |                         |                   |
|-------------------------|-------------------|
| (1) Clutch Pinion Shaft | (5) Steel Ball    |
| (2) Plunger Shaft       | (6) Holding Coil  |
| (3) Return Spring       | (7) Pull-in Coil  |
| (4) Plunger             | (8) Contact Plate |

The magnet switch series as a relay to drive the armature. It consists of a pull-in coil, a holding coil and a plunger. It works as follows.

1. When the main switch is at the **START** position, the armature is rotated at a small amperage as the pull-in coil (7) and the holding coil (6) attract the plunger (4) to the left.
2. When the main circuit from the contact plate (8) to armature is closed by the plunger (4), the armature starts rotating at a strong torque. At the same time, a current stops flowing into the pull-in coil and the plunger is kept attracted by the holding coil alone.
3. When the main switch is released from the **START** position after starting the engine, it returns to the **ON** position so that the flow of a current to the holding coil also stops. Thus, the armature stops rotating.

**(1)-3 Operation of Starter Motor**

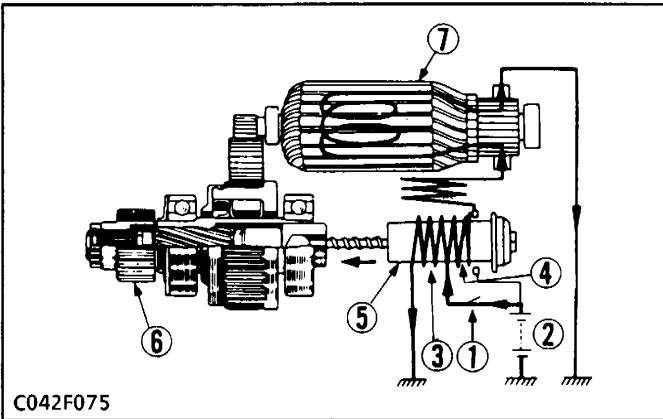

■ **When the Main Switch is Turned to "START" Position**

With the main switch (1) is at the **START** position, current flows from the battery (2) to the holding coil (3) and pull-in coil (4). This moves the plunger (5) electromagnetically and pushes out the pinion gear (6). At the same time, current flowing through the pull-in coil (4) rotates the armature (7) at low speeds.

- |                  |                 |
|------------------|-----------------|
| (1) Main Switch  | (5) Plunger     |
| (2) Battery      | (6) Pinion Gear |
| (3) Holding Coil | (7) Armature    |
| (4) Pull-in Coil |                 |

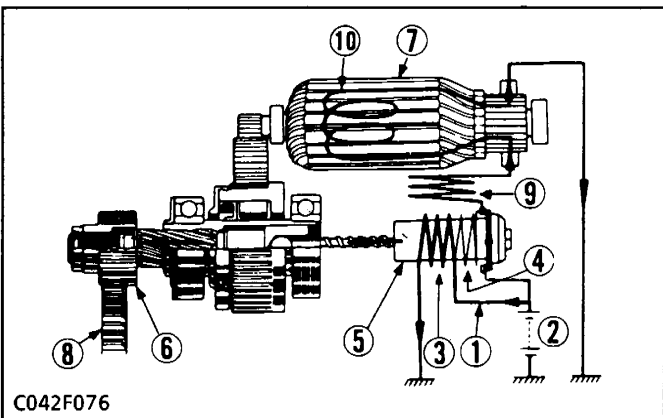

■ **When the Pinion Gear Meshes with the Ring Gear**

When the pinion gear (6) comes into mesh with the ring gear (8) on the flywheel, a large current flows from the battery directly into the field coil (9) and armature coil (10), but not through the pull-in coil (4). This rotates the armature (7) at a high speed, which in turn drives the ring gear through the pinion gear at 200 to 300 rpm.

- |                  |                    |
|------------------|--------------------|
| (1) Main Switch  | (6) Pinion Gear    |
| (2) Battery      | (7) Armature       |
| (3) Holding Coil | (8) Ring Gear      |
| (4) Pull-in Coil | (9) Field Coil     |
| (5) Plunger      | (10) Armature Coil |

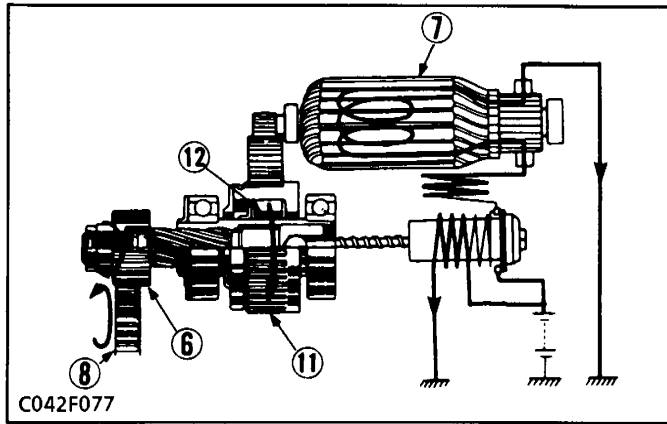

■ When the Engine is Running

When the engine runs so fast that the ring gear (8) starts to turn the pinion gear (6), the roller clutch (11), (12) are actuated to prevent excessive high-speed revolutions of the armature (7).

- (6) Pinion Gear
- (7) Armature
- (8) Ring Gear
- (11) Clutch Gear
- (12) Roller

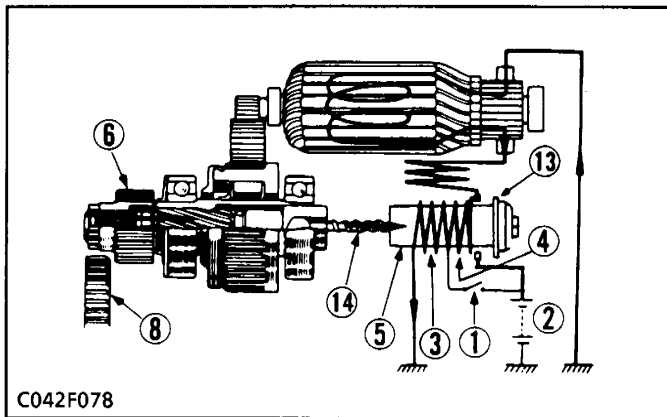

■ When the Main Switch is Released

When the main switch (1) released, the main switch returns from the **START** to the **ON** position and opens the starter circuit. Then, current flows from the battery (2) to the pull-in coil (4) and holding coil (3) through the contact plate (13). Since the magnetic forces of the pull-in coil and holding coil become partially opposed and cancel one another, the plunger (5) is restored by the tension of the return spring (14).

This opens the contacts on the contact plate and separates the pinion gear (6) from the ring gear (8), so that the pinion gear stops rotating.

- (1) Main Switch
- (2) Battery
- (3) Holding Coil
- (4) Pull-in Coil
- (5) Plunger
- (6) Pinion Gear
- (8) Ring Gear
- (13) Contact Plate
- (14) Return Spring

(2) Glow Control System

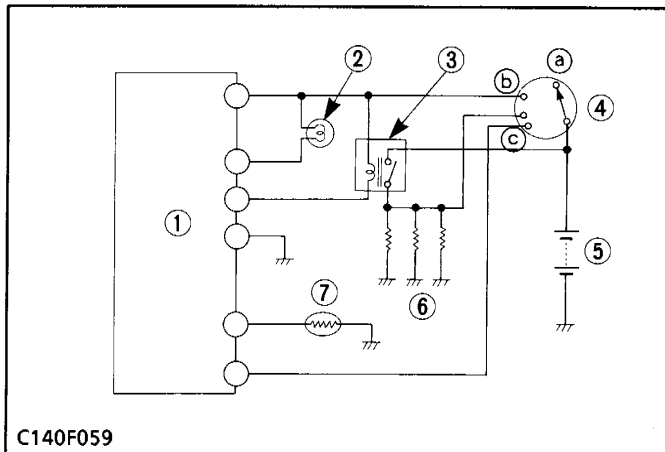

This preheater employs an **ON** glow system which supplies current to the glow plug (6) for a necessary length of time by simply turning on the main switch (4).

The structure of this system is as shown in the figure. The energizing time of this glow plug (6) is controlled by the temperature of cooling water of the engine. When the glow lamp (2) is turned off, the operator knows that the preheating is completed.

The glow plug (6) is provided with a super glow plug which is capable of heating quickly in a short time.

- (a) OFF
- (b) ON
- (c) START
- (1) Glow Controller
- (2) Glow Lamp
- (3) Glow Relay
- (4) Main Switch
- (5) Battery
- (6) Glow Plug
- (7) Water Temperature Sensor

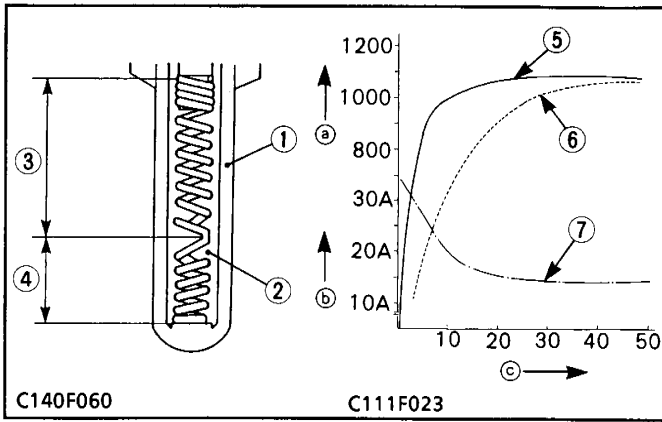

- (a) Glow Plug Temperature (°C)
- (b) Current (A)
- (c) Time (Sec.)
- (1) Sheath Tube
- (2) Insulation Powder
- (3) Heater also functioning as a Resistor
- (4) Heater
- (5) Super Glow Plug
- (6) Conventional Quick-heating type Glow Plug
- (7) Glow Plug Current

**Super Glow Plug**

This plug is a two-material type QGS (Quick Glow System) for quick temperature rise, and has self-controlling function as well as excellent durability.

The heater (4) connected in series to the heater (3), which also functions as the resistor, is incorporated in the sheath tube (1) of the super glow plug.

The resistance of this heater (3) cum resistor is small when the temperature is low, while the resistance becomes large when the temperature rises.

Therefore, because sufficient current is flown to the heater (4) during the initial period of energization, the temperature rises quickly and the resistance grows with the rise in the temperature of the resistor, the flowing current is reduced to prevent the heater (4) from being heated.

The ignition point is in the area of 2 to 3 mm (0.079 to 0.118 in.) from the tip of the plug in order to reduce its projection into the combustion chamber.

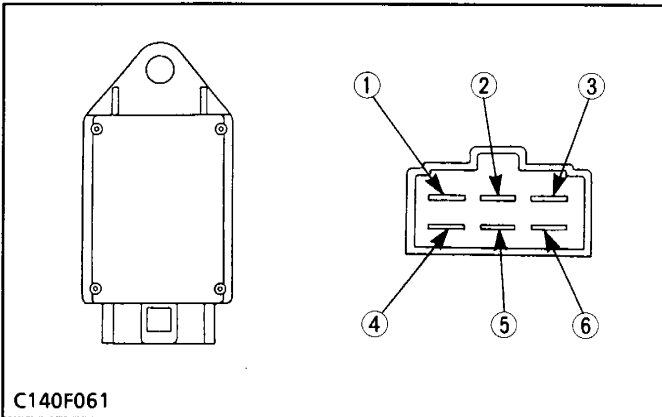

**Glow Controller**

The glow controller detects the cooling water temperature by means of the water temperature sensor, and controls the time to supply current to the glow plug and the glow lamp according to the detected water temperature. The relation between the water temperature and the time of current supply is as shown in the figure.

**(A) Characteristic of Glow Controller Timer**

- (a) Time (Sec.)
- (b) Water Temperature (°C)
- (1) From Main Switch ST
- (2) From Glow Lamp
- (3) From Main Switch AC
- (4) To Water Temperature Sensor
- (5) From Glow Relay
- (6) To Ground

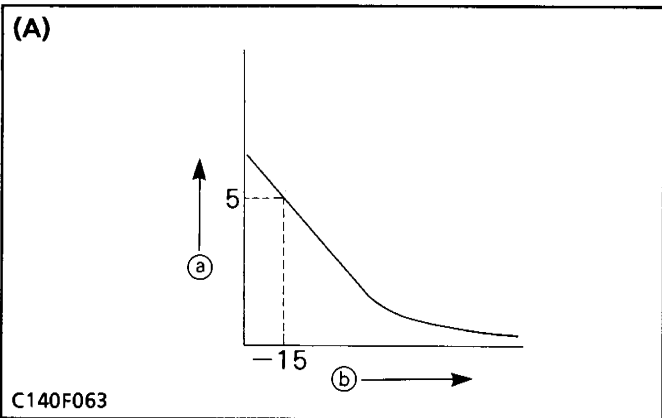

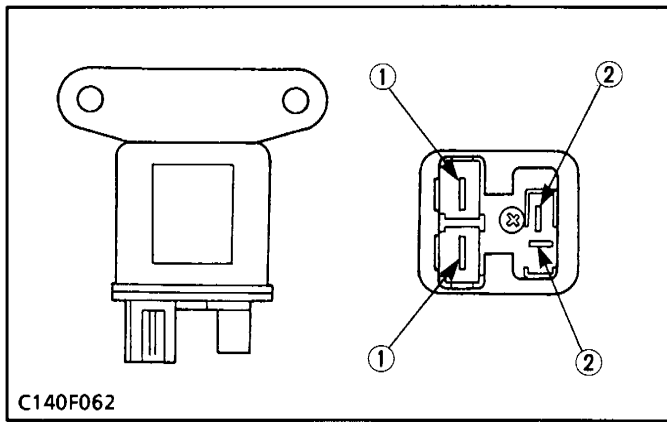

**■ Glow Relay**

The glow relay is actuated by the signal from the glow controller and supplies the battery power to the glow plug directly.

- (1) Contact Point
- (2) Coil

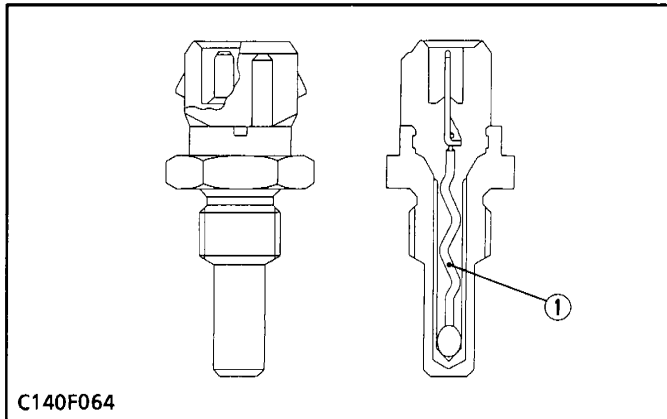

**■ Water Temperature Sensor**

A water temperature sensor for glowing is provided on the thermostat unit of the engine.

The water temperature sensor incorporates the thermistor (1). When the water temperature is high, the resistance of the thermistor is small, and when the water temperature is low, the resistance becomes large.

Temperature	Resistance
- 20 °C (- 4 °F)	16.2 kΩ
0 °C (32 °F)	3.88 kΩ
20 °C (68 °F)	2.45 kΩ
40 °C (104 °F)	1.14 kΩ
60 °C (140 °F)	0.58 kΩ
80 °C (176 °F)	0.32 kΩ

- (1) Thermistor

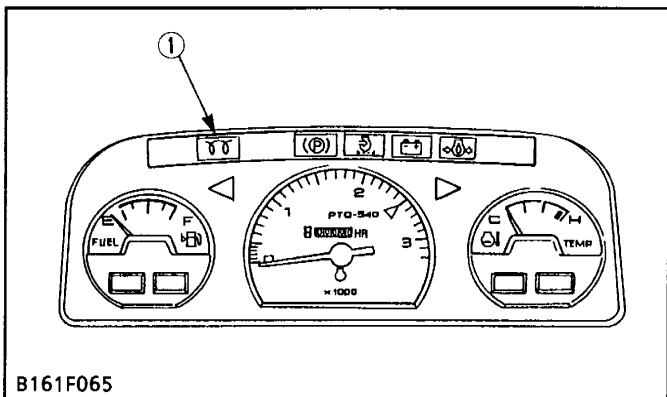

**■ Glow Lamp**

The glow lamp (1) is provided inside the meter panel. When the preheating is completed (engine can be started), the glow lamp goes out.

- (1) Glow Lamp



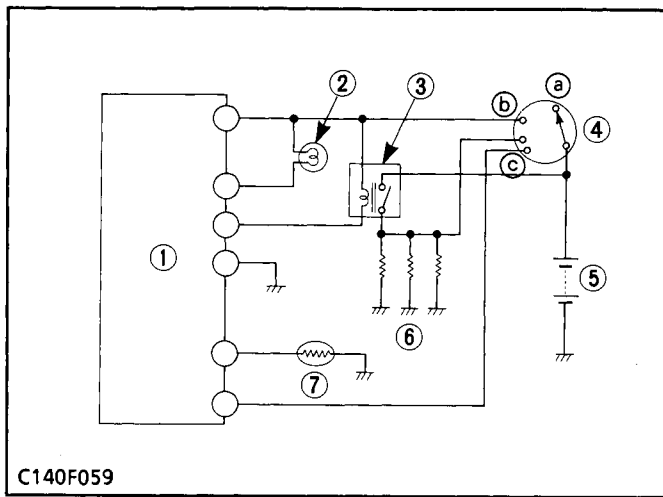

(a) OFF  
(b) ON

(c) START

(1) Glow Controller  
(2) Glow Lamp  
(3) Glow Relay  
(4) Main Switch

(5) Battery  
(6) Glow Plug  
(7) Water Temperature Sensor

#### ■ Function

1. When the main switch (4) is turned ON, the glow relay (3) is turned on by the glow controller (1), allowing the current to flow to the glow plug (6). The current flows simultaneously to the glow lamp (2) to turn it on.
2. The glow relay (3) is turned off after it is preheated for an appropriate length of time according to the cooling water temperature detected by the water temperature sensor (7). The glow lamp (2) is turned off at the same time to inform the operator of the completion of preheating.
3. When the main switch (4) is set to START position, the current flows from the main switch (4) to the glow plug (6) to make the starting easy. When the main switch (4) is set to START position during preheating, the glow relay (3) is turned off to turn off the glow lamp (2).

## [4] ENGINE KEY SWITCH SHUT-OFF SYSTEM

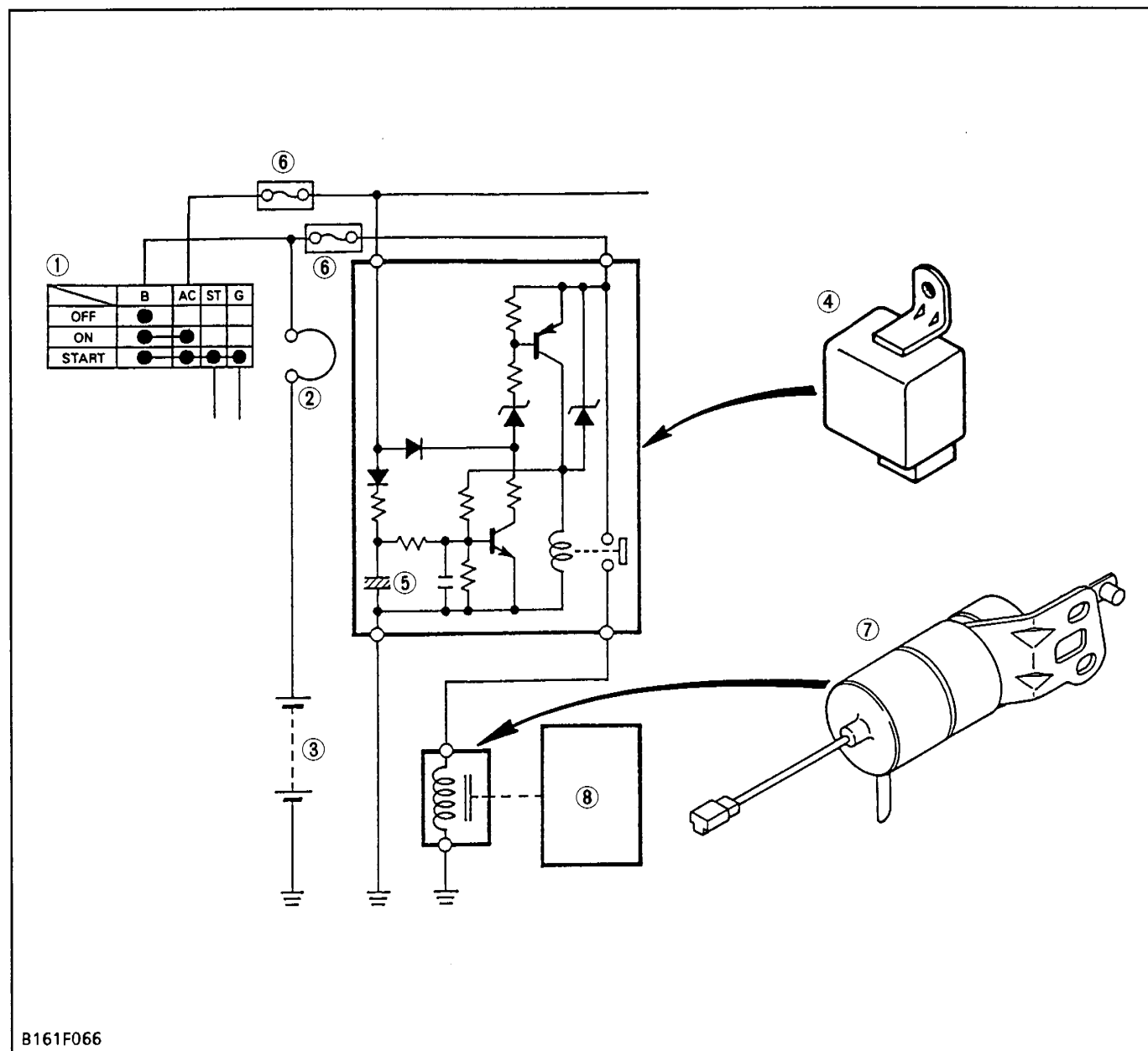

(1) Main Switch  
(2) Slow Blow Fuse

(3) Battery  
(4) Timer Relay

(5) Capacitor  
(6) Fuse

(7) Fuel Cut Off Solenoid  
(8) Fuel Injection Pump

On the engine key switch shut-off system, turning the main switch from the **ON** position to the **OFF** position moves the fuel injection pump control rack to the "No Fuel Injection" position through the fuel cut off solenoid and the same linkage as when the stop lever is operated by manual operation.

As soon as the main switch (1) is turned from the **ON** position to the **OFF** position, the capacitor starts discharging and continues it for approx. 10 seconds.

During the discharging period, the current flows as follows:

Battery (3) → Main Switch (1) → Timer Relay (4) → Fuel Cut Off Solenoid (7) → Ground.

Then, the engine stops.

After 10 seconds, the relay contact point in the timer open to prevent the battery from overdischarging.

**(1) Operation of Timer Relay**

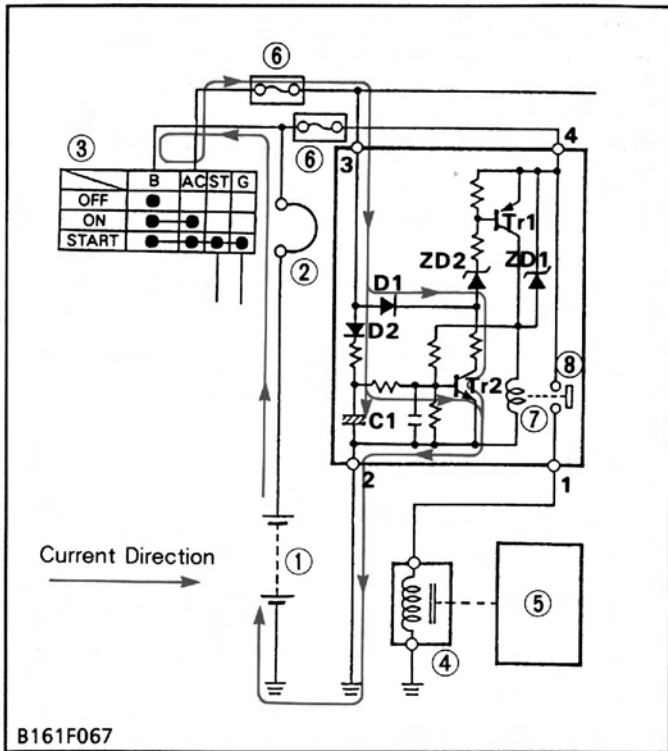

**■ When the Main Switch is Turned to "ON" Position**

The capacitor C1 is charged by the battery current flowing through the terminal 3 immediately after the main switch (3) is turned to the ON position.

1. The transistor Tr2 is then turned on.
2. The transistor Tr1 remains off because the battery voltage is applied to the anode of the zener diode ZD2.
3. Therefore, the relay coil (7) does not conduct, and the relay contact points (8) remain open so that the battery current does not flow into the fuel cut off solenoid (4).

**(Reference)**

- The critical voltage of zener diode ZD2 is about 5 volts.

- |                           |                    |
|---------------------------|--------------------|
| (1) Battery               | (5) Injection Pump |
| (2) Slow Blow Fuse        | (6) Fuses          |
| (3) Main Switch           | (7) Relay Coil     |
| (4) Fuel Cut Off Solenoid | (8) Contact Point  |

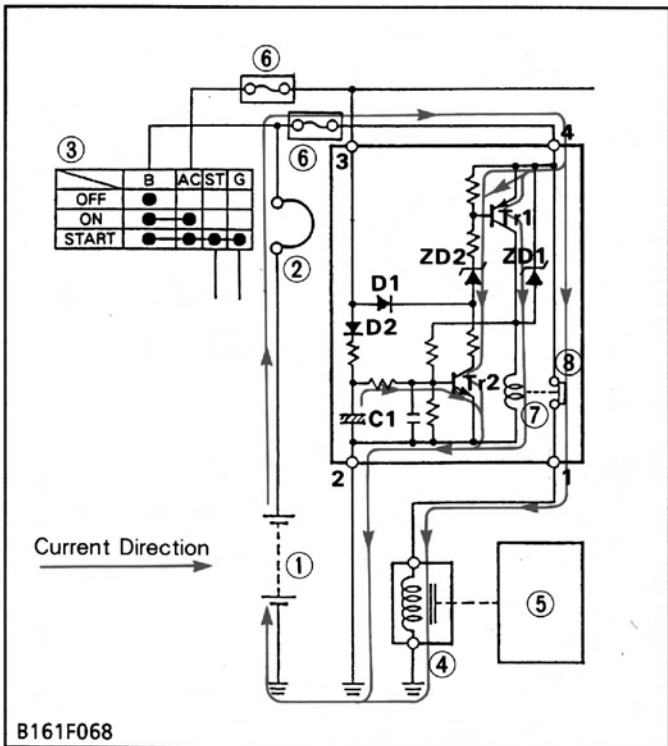

**■ When the Main Switch is Turned to "OFF" Position**

Changes described below take place in the timer to stop the engine when the main switch (3) is turned to the OFF position.

1. The battery voltage is not applied to the terminal 3.
2. Since the discharge current from capacitor C1 flows into the base of transistor Tr2, it is held ON state.
3. The voltage at the anode of the zener diode ZD2 becomes low, and the voltage across the zener diode ZD2 exceeds the critical voltage so that this zener diode conducts.
4. Consequently, the battery current supplied from the terminal 4 begins to flow from the collector to the emitter of the relay drive transistor Tr1.
5. The transistor Tr1 is then turned on, and the battery current flows into the relay coil (7) to close relay contact point (8).
6. The battery current flows into the fuel cut off solenoid (4) via the terminals 4 and 1.
7. As a result, the amount of the fuel injected from the injection pump (5) becomes zero to stop the engine.
8. The transistor Tr2 turns off after the discharging period approx. 10 seconds of the capacitor C1.

No current flows through the circuit, and then the relay contact point (8) opens so that the battery current does not flow into the fuel cut off solenoid (4).

- |                           |                    |
|---------------------------|--------------------|
| (1) Battery               | (5) Injection Pump |
| (2) Slow Blow Fuse        | (6) Fuses          |
| (3) Main Switch           | (7) Relay Coil     |
| (4) Fuel Cut Off Solenoid | (8) Contact Point  |

**(2) Fuel Cut Off Solenoid**

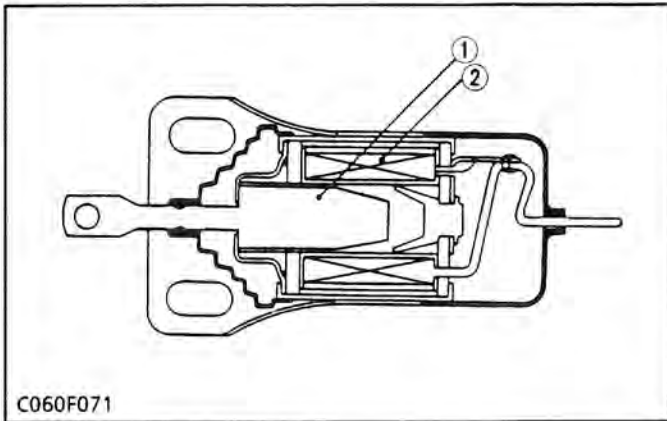

Flowing of the battery current into the coil (2) while the timer relay contact point is closed attracts the plunger (1) to actuate the stop lever of the injection pump. When the battery current stops, the plunger is returned to the original position by the spring.

- (1) Plunger
- (2) Coil

**[5] CHARGING SYSTEM**

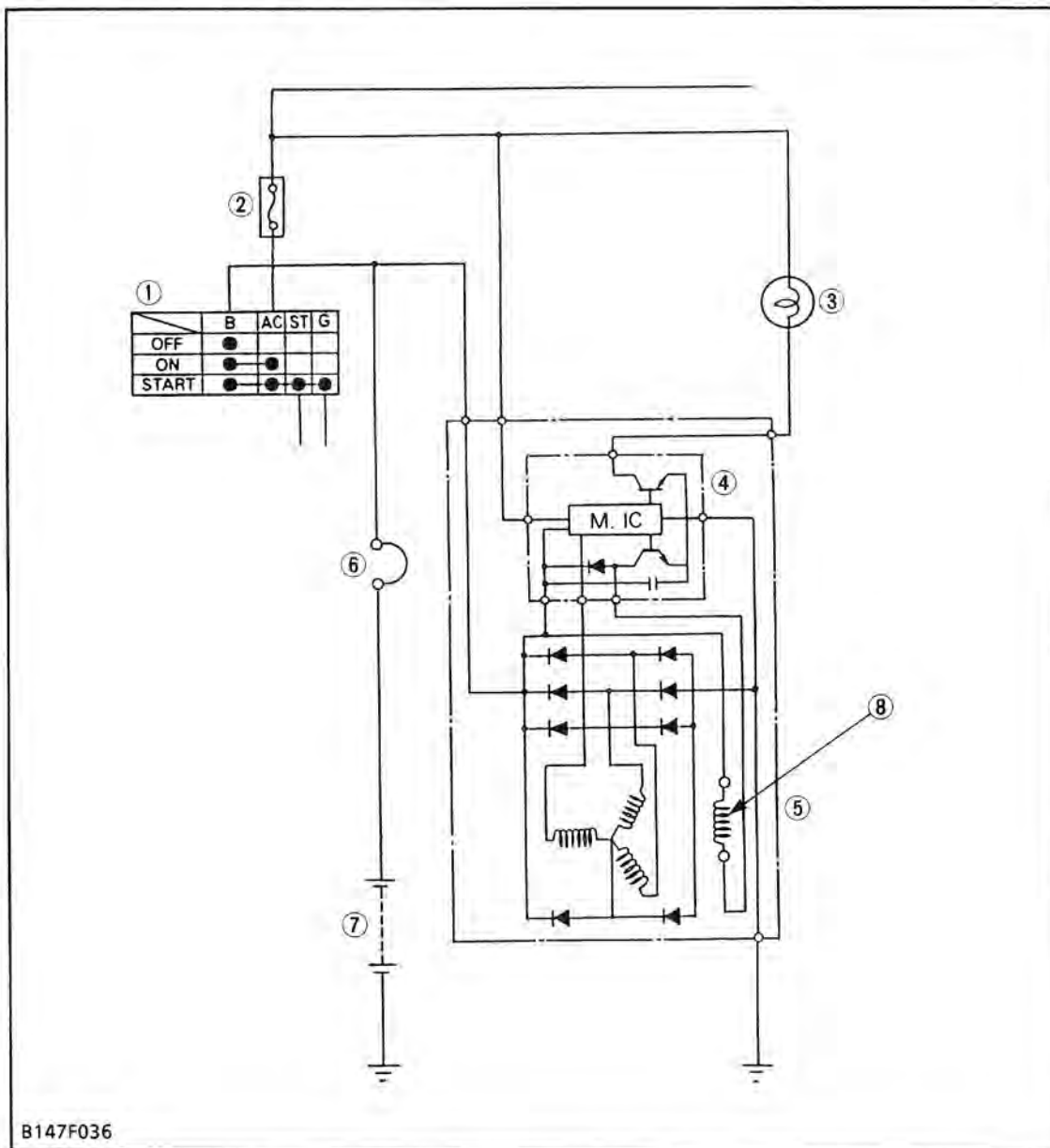

- (1) Main Switch
- (2) Fuse
- (3) Charge Lamp
- (4) IC Regulator
- (5) Alternator
- (6) Slow Blow Fuse
- (7) Battery
- (8) Rotor Coil

B147F036

The charging system supplies electric power for various electrical devices and also charges the battery while the engine runs. This alternator has IC regulator.

## (1) Alternator

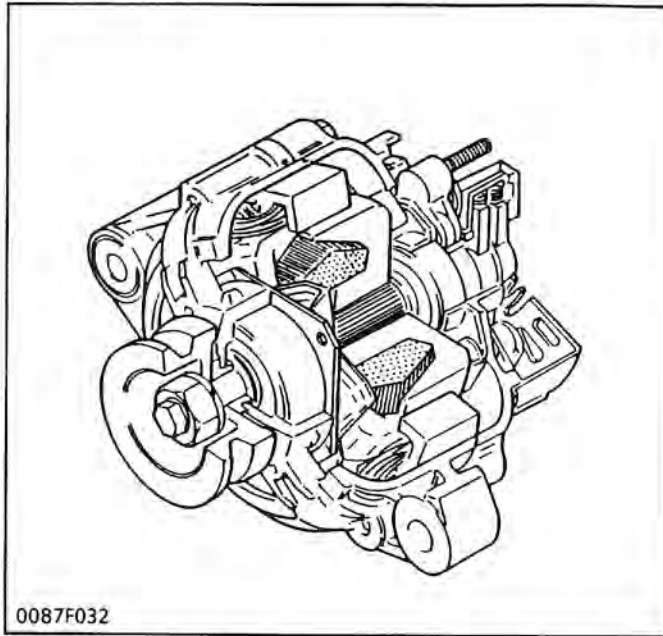

A compact alternator with an IC regulator is used, having the following characteristics :

- Approximately 26 % lighter and 17 % smaller than a standard alternator.
- Cooling performance and safety have been improved by combining the cooling fan with the rotor and incorporating the fan/rotor unit inside the alternator.
- IC regulator is fitted inside the alternator.
- The rectifier, IC regulator and similar components are easy to remove, making it easier to service the alternator.

## (2) IC Regulator

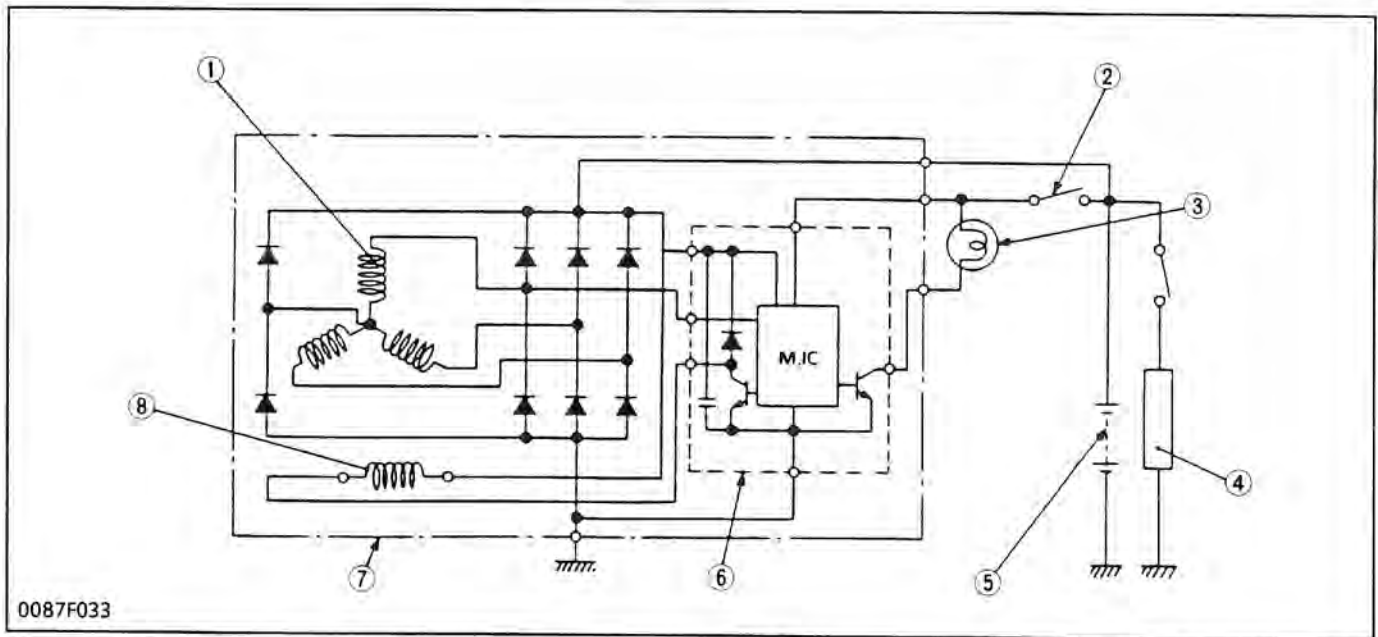

- |                 |                 |                  |                |
|-----------------|-----------------|------------------|----------------|
| (1) Stator Coil | (3) Charge Lamp | (5) Battery      | (7) Alternator |
| (2) Main Switch | (4) Load        | (6) IC Regulator | (8) Rotor Coil |

An IC regulator uses solid state transistors, chips or other semiconductor elements instead of the relays in a conventional regulator. Stable characteristics are achieved by cutting off the field current.

IC regulators have the following characteristics :

- The control voltage does not change over time, so the need for readjustment is eliminated. Since there are no moving parts, IC regulators are extremely durable and resistant to vibration.
- The overheat compensation characteristics ensure that the control voltage is reduced as the temperature rises, so the battery is charged at just the right level.

The internal circuitry of the IC regulator is shown in the diagram. It consists of a hybrid IC incorporating a monolithic IC. (The internal circuitry of the monolithic IC is extremely complex, so it is shown as simply "M.IC circuit".

Tr1 acts as the contacts controlling the field current, and Tr2 acts as the charge lamp relay controlling the flashing of the charge lamp.

The M.IC circuit controls Tr1 and Tr2, and monitors the alternator output voltage, and detects any drop in L terminal voltage or breaks in the rotor coil.

### (3) Operation of Charging System

#### ■ When Main Switch is Turned To "ON" Position

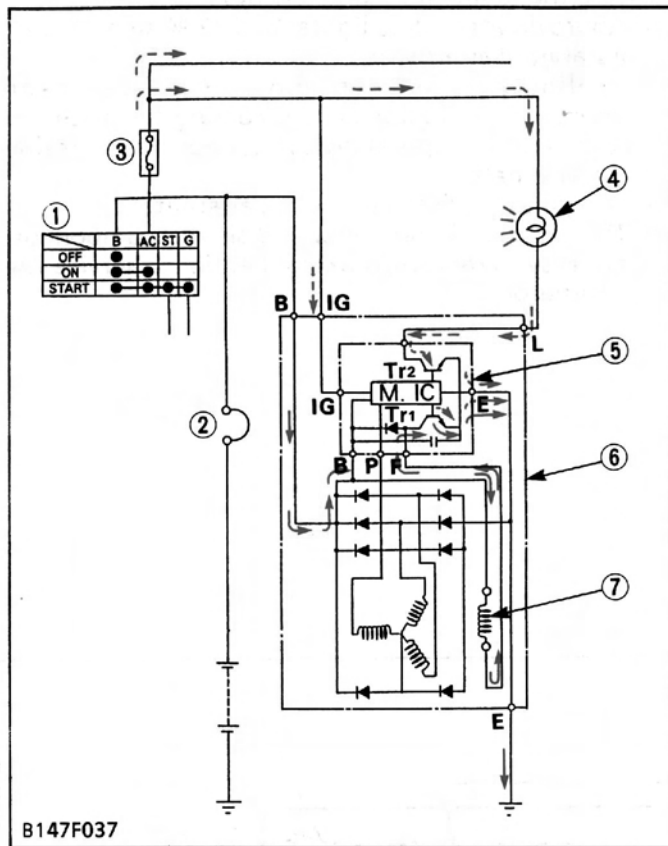

As the battery voltage is added to the terminal IG, M.I.C circuit detect it and makes current pour to the Tr1. It results to pour the initial exciting current to the rotor coil. (In this case, M.I.C circuit makes current pour on and off the Tr1 in pulse and limits the battery discharging current to small value (Approx. 0.17 A) when the main switch is turned on.)

As the alternator is not rotated, it doesn't generate. Therefore the voltage of terminal P is zero volt. M.I.C circuit detects it and makes current pour to the Tr2. It results light on the charge lamp.

M.I.C : Monolithic IC  
Tr1 : Transistor

Tr2 : Transistor

- (1) Main Switch
- (2) Slow Blow Fuse
- (3) Fuse
- (4) Charge Lamp

- (5) IC Regulator
- (6) Alternator
- (7) Rotor Coil

#### ■ When Engine Starts

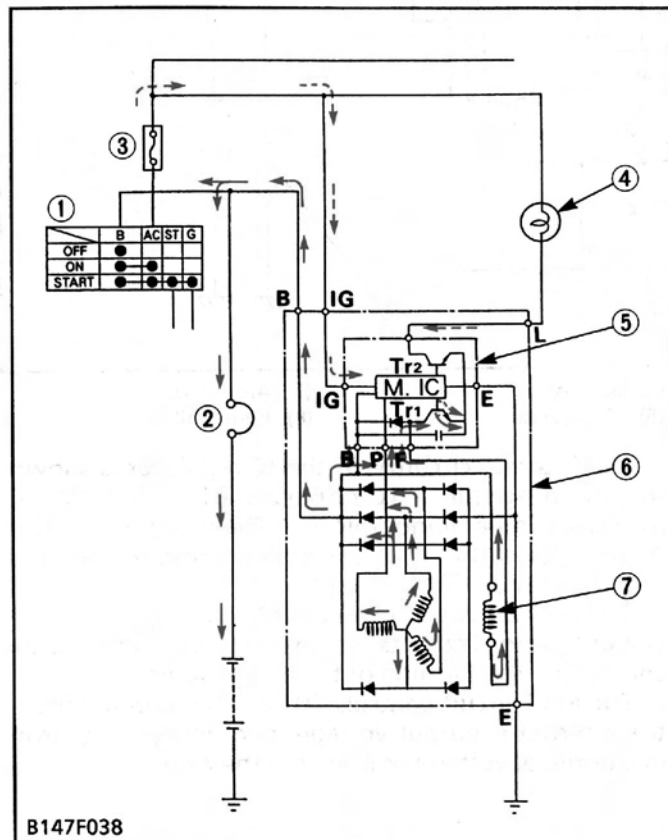

When the engine starts and the alternator rotates, M.I.C circuit makes current pour continuously to the Tr1 instead of the uncontinuous (in pulse) current. Therefore a sufficient exciting current flows and a generated voltage rises rapidly. As a result, the current to the Tr2 is shut and lights off the charge lamp.

When terminal B voltage rises over the battery voltage, a charged current flows to the battery.

M.I.C : Monolithic IC  
Tr1 : Transistor

Tr2 : Transistor

- (1) Main Switch
- (2) Slow Blow Fuse
- (3) Fuse
- (4) Charge Lamp

- (5) IC Regulator
- (6) Alternator
- (7) Rotor Coil

# [6] LIGHTING SYSTEM

## (1) Head Light

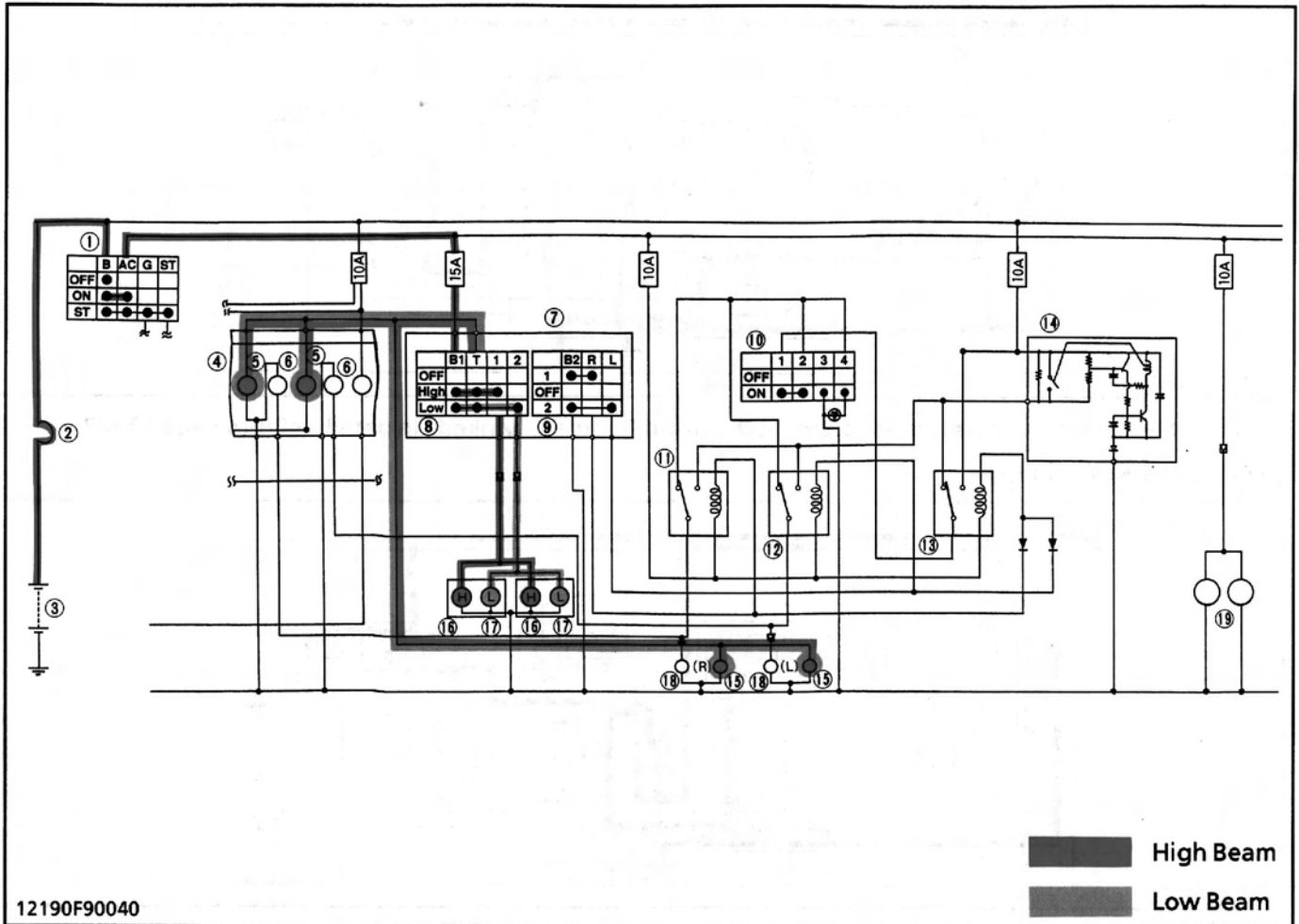

12190F90040

- |                               |                            |                            |  |
|-------------------------------|----------------------------|----------------------------|--|
| (1) Main Switch               | (7) Combination Switch     | (13) Hazard Relay          | (18) Hazard Lights                         |
| (2) Slow Blow Fuse            | (8) Light Switch           | (14) Hazard Unit           | (19) Working Lights                        |
| (3) Battery                   | (9) Turn Signal Switch     | (15) Tail Lights           |  |
| (4) Panel Board               | (10) Hazard Switch         | (16) Head Lights HIGH-beam | <b>a : From Battery</b>                    |
| (5) Panel Board Illuminations | (11) Turn Signal Relay (R) | (17) Head Lights LOW-beam  | <b>b : From AC Terminal of Main Switch</b> |
| (6) Hazard Indicator Lamps    | (12) Turn Singal Relay (L) |                            |  |

The lighting system consists of combination switch (light switch and hazard switch), head lights, tail lights, panel board illuminations, hazard unit, hazard lights, hazard indicator lamps, working lights, etc.

The light switch, which forms a combination switch with the hazard switch, has three position; **OFF, LOW-BEAM and HIGH-BEAM.**

**(2) Hazard Light and Turn Signal Light**

**(2) -1 Hazard Light**

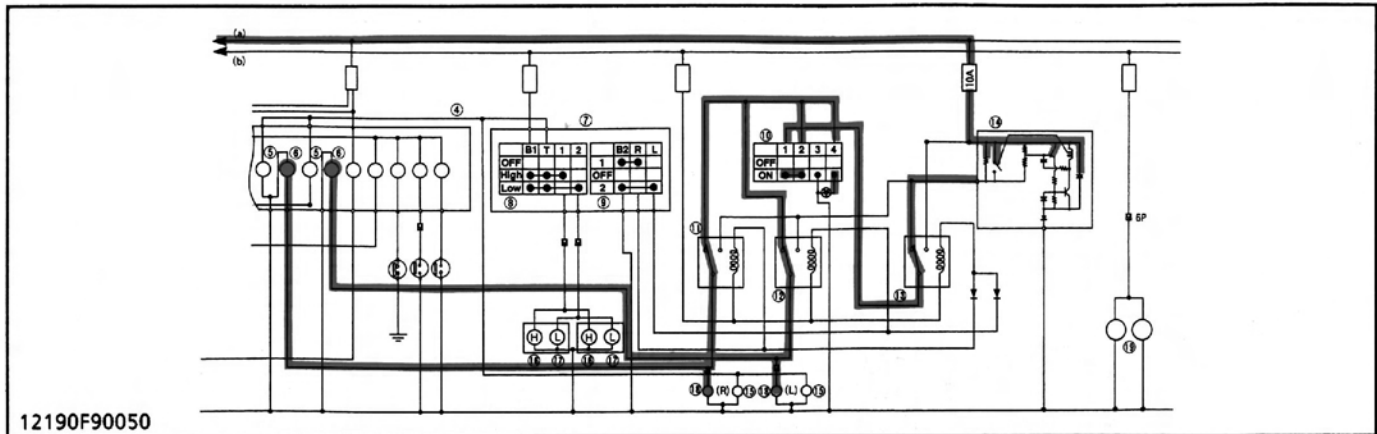

12190F90050

When the hazard switch is turned to ON, both hazard lights are winked. In detail, refer to page 10-M7.

**(2) -2 Turn Signal Light**

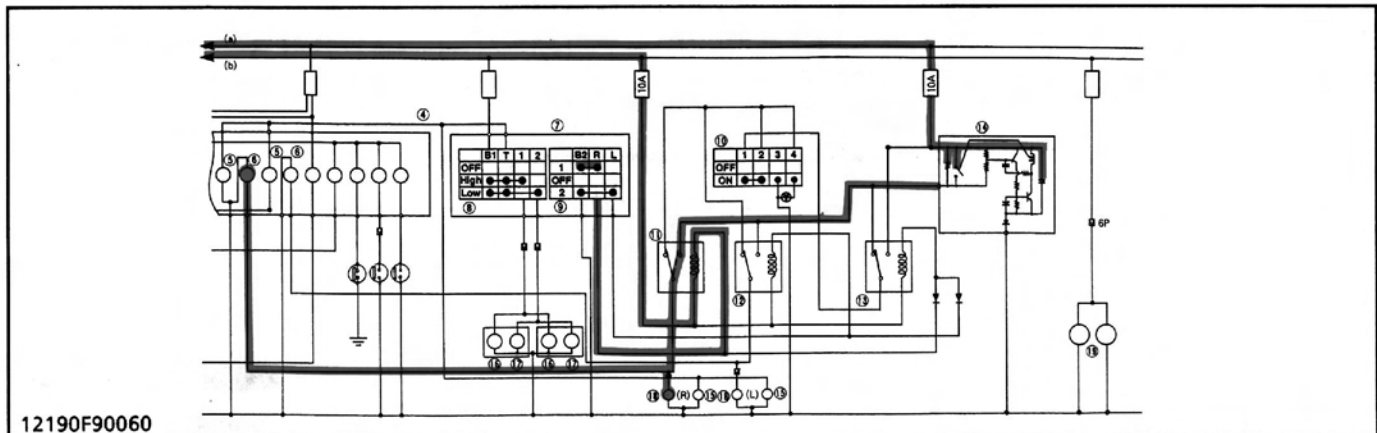

12190F90060

Above figure shows the current in case of right turn signal switch being turned to "R" position. In detail, refer to page 10-M8.

**(2) -3 Hazard Light with Turn Signal Light**

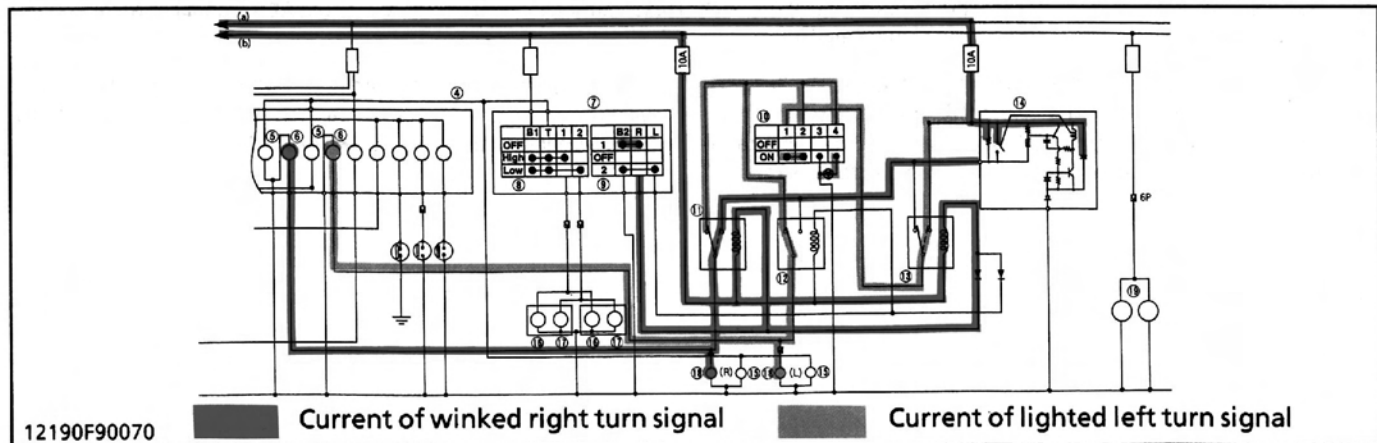

12190F90070

Current of winked right turn signal

Current of lighted left turn signal

- |                               |                            |                              |                                     |
|-------------------------------|----------------------------|------------------------------|-------------------------------------|
| (4) Panel Board               | (9) Turn Signal Switch     | (14) Hazard Unit             | (19) Working Lights                 |
| (5) Panel Board Illuminations | (10) Hazard Switch         | (15) Tail Light              |                                     |
| (6) Hazard Indicator Lamps    | (11) Turn Signal Relay (R) | (16) Head Lights (High Beam) | a : From Battery                    |
| (7) Combination Switch        | (12) Turn Signal Relay (L) | (17) Head Lights (Low Beam)  | b : From AC Terminal of Main Switch |
| (8) Light Switch              | (13) Hazard Relay          | (18) Hazard Lights           |                                     |

Above figure shows the current in case of right turn signal switch being turned "R" position and hazard switch ON. Right turn signal is winked but left turn signal is kept to light ON. In detail, refer to page 10-M9.

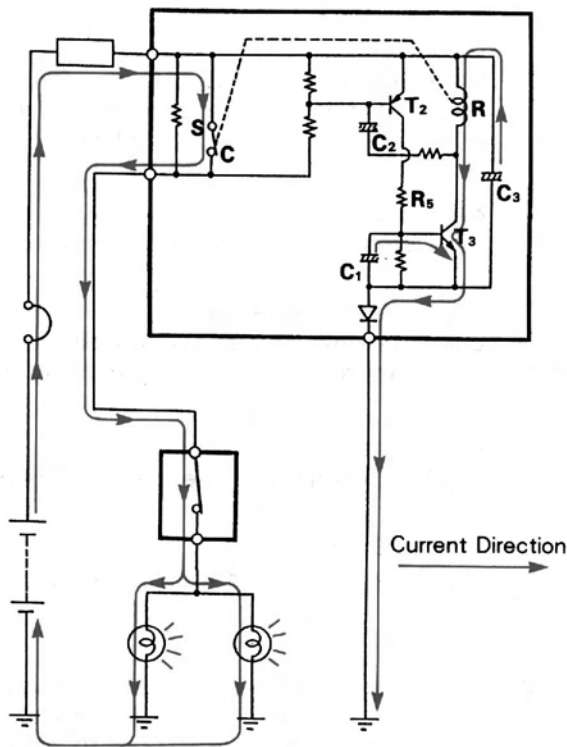

**[When the Hazard Lights "ON"]**

B161F072

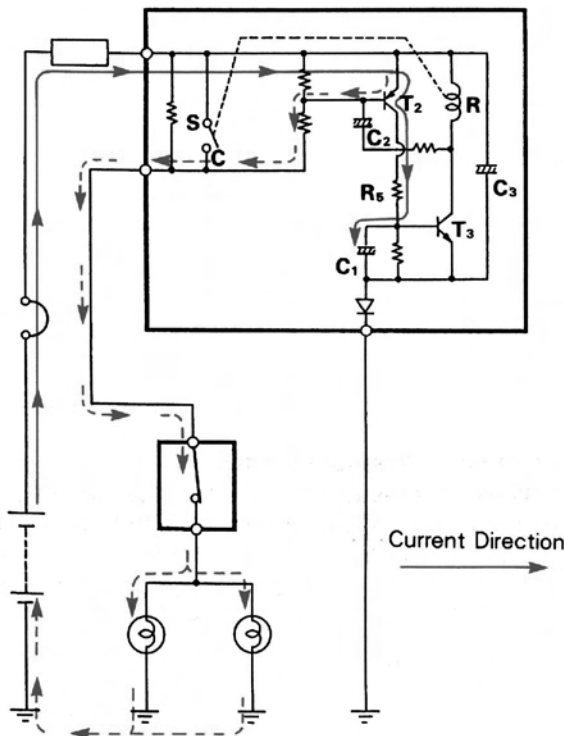
**[When the Hazard Lights "OFF"]**

B161F073

**■ Hazard Unit**

The hazard unit, consisting of a capacitor, transistors, diodes, resistors and the other parts, sends intermittent current to the hazard lights. Intermittent current is generated in the following sequence.

1. When the hazard switch is turned **OFF**, voltage from the battery is applied to capacitors **C2** and **C3**, causing the capacitor always to be overcharged and the circuit to be opened.
2. When the hazard switch is turned **ON**, the capacitor **C2** starts discharging. When the discharged voltage of the capacitor **C2** is lower than the voltage of battery and the potential difference becomes large, the base current of the transistor **T2** increases and turn on the transistor **T2**.
3. Battery current flowing through the transistor **T2** goes through the resistor **R5** and charges the capacitor **C1**.
4. When the capacitor **C1** is fully charged, the current from the resistor **R5** becomes the base current of the transistor **T3** and turn on the transistor **T3**.
5. When the transistor **T3** is turned on, battery current magnetizes the coil **R**. As the contact **S** is drawn to be connected with the terminal **C**, the battery current flows through the hazard switch and turns on the hazard lights.
6. When the hazard light is lighted, all the battery current flow through the contact **S** and will not flow through the coil **R**. But, the current discharged from the capacitor **C1** becomes the base current to maintain the transistor **T3** in **ON** mode. Current discharged from the capacitor **C3** flows through the coil **R** and keeps the hazard lights turned on.
7. When the capacitor **C1** completes discharging, no base current is present in the transistor **T3**, turning off the transistor **T3**. Then the current from the capacitor **C3** to the coil **R** is shut off, causing the contact **S** to move away from the terminal **C**, and the hazard lights are turned off.
8. The capacitor **C1** controls the time from turning on to turning off the light, while the capacitor **C2** and resistor **R2** control the lighting time.

## [7] EASY CHECKER

### (1) Indication Items

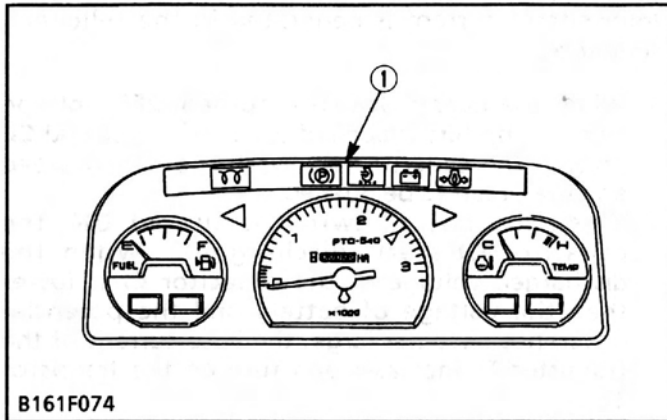

(1) Easy Checker

**LF-34 Glow Lamp**  
When the main switch **ON**, the lamp is **ON** and the combustion chamber is heated. After heating, the lamp turns **OFF**.

**LF-35 Battery Charge Lamp**  
Light up when battery charging is improper.

**LF-36 Engine Oil Pressure Lamp**  
Light up when the engine oil pressure drops below approx. 49 kPa (0.5 kgf/cm<sup>2</sup>, 7.1 psi)

**LF-37 Air Cleaner Clogged Lamp**  
Light up when the air cleaner is clogged.

**LF-38 Parking Brake Lamp**  
Light up when the parking brake operation.

### (2) Engine Oil Pressure Alarm

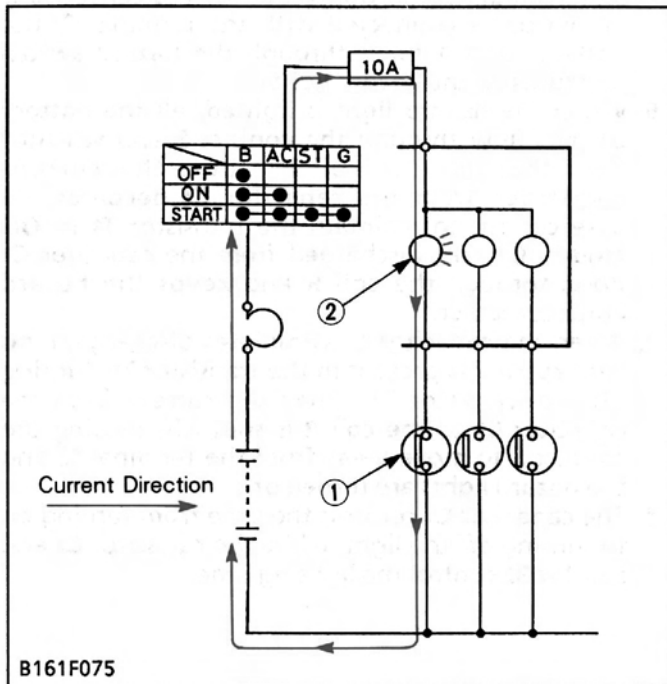

When the engine oil pressure has dropped, the engine oil pressure switch (1) is activated to let the current flow from the main switch and to light up the lamp (2).

(1) Engine Oil Pressure Switch      (2) Engine Oil Pressure Lamp

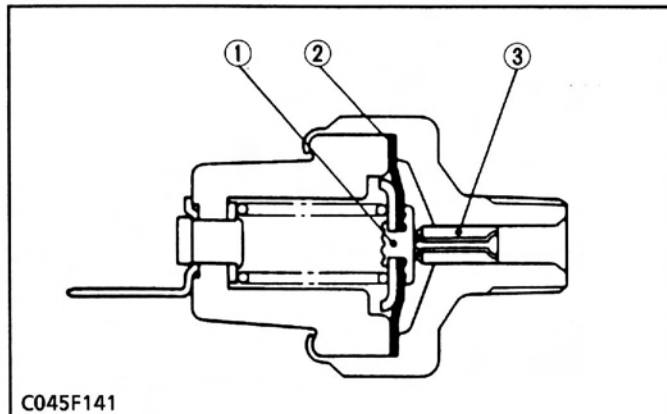

#### ■ Engine Oil Pressure Switch

While oil pressure is high and the force applied to the diaphragm (2) is larger than the spring tension, the terminal contact (1) is open separated from the body contact (3). If the pressure drops below approx. 49 kPa (0.5 kgf/cm<sup>2</sup>, 7.1 psi), the contact closes.

(1) Terminal Contact      (3) Body Contact  
(2) Diaphragm

### (3) Air Cleaner Clogged Lamp

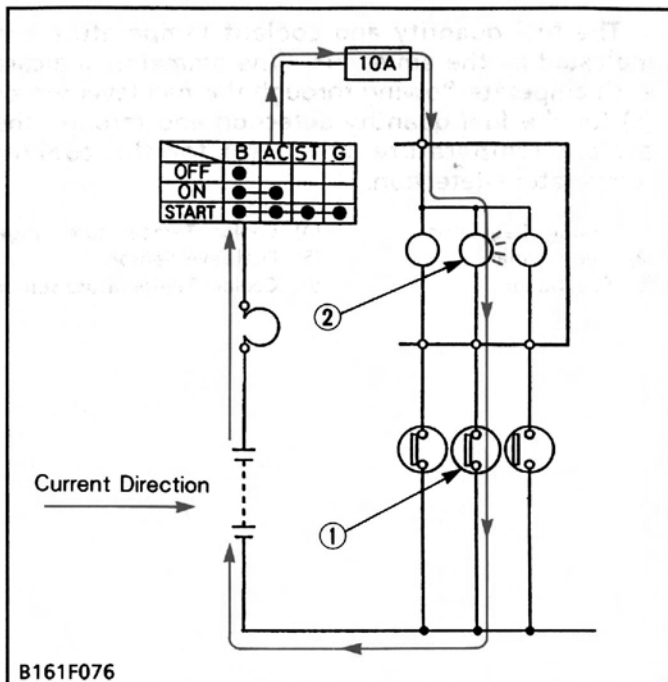

B161F076

When the air cleaner is clogged and the negative pressure of the suction air increases, the air cleaner sensor (1) is turned **ON**, causing the current to flow from the main switch and the lamp (2) is lighted.

- (1) Air Cleaner Sensor
- (2) Air Cleaner Clogged Lamp

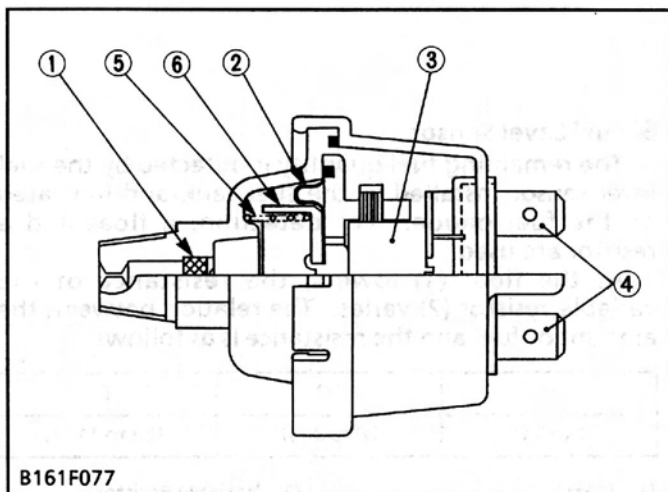

B161F077

#### ■ Air Cleaner Sensor

The micro switch (3) is normally opened. When the air cleaner is clogged, the negative pressure is created in the outlet port of air cleaner and the diaphragm (2) is attracted. And the micro switch is turned on when the negative pressure exceeds approx. 6.22 kPa (635 mmAq.).

- (1) Filter
- (2) Diaphragm
- (3) Micro Switch
- (4) Terminals
- (5) Spring
- (6) Guide

**[8] GAUGES**

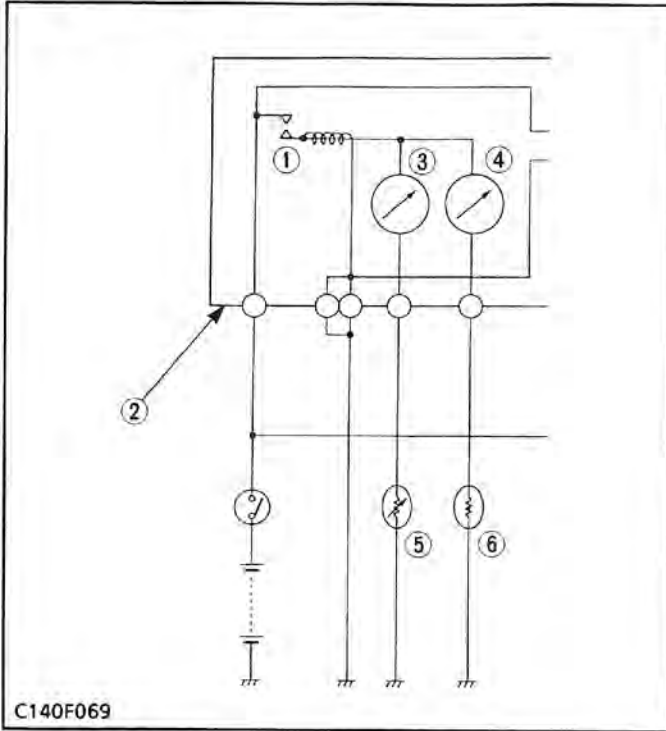

C140F069

The fuel quantity and coolant temperature are indicated by the ammeters. The ammeters indicate each amperate flowing through the fuel level sensor (5) for the fuel quantity detection and through the coolant temperature sensor (6) for the coolant temperature detection.

- (1) Voltage Regulator
- (2) Meter Panel
- (3) Fuel Gauge
- (4) Coolant Temperature Gauge
- (5) Fuel Level Sensor
- (6) Coolant Temperature Sensor

**(1) Sensor**

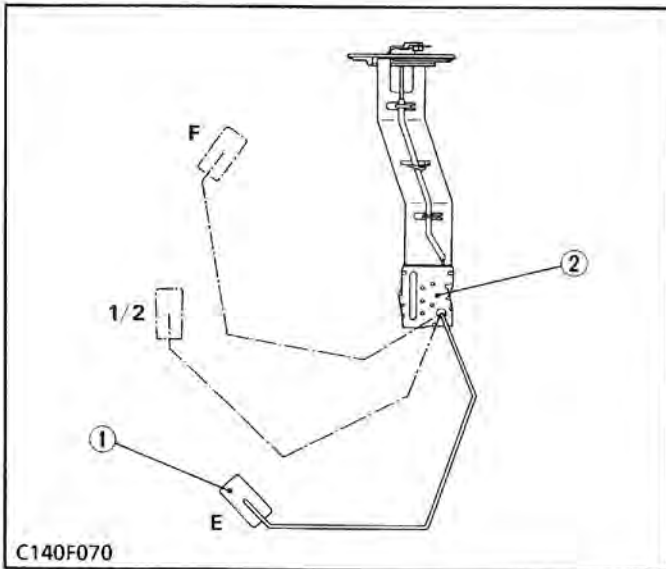

C140F070

**■ Fuel Level Sensor**

The remaining fuel quantity is detected by the fuel level sensor installed in the fuel tank and indicated on the fuel gauge. For detection, a float and a resistor are used.

As the float (1) lowers, the resistance of the variable resistor (2) varies. The relation between the amount of fuel and the resistance is as follows.

F	1/2	E
1 to 5 Ω	28 to 36 Ω	103 to 117 Ω

- (1) Float
- (2) Variable Resistor

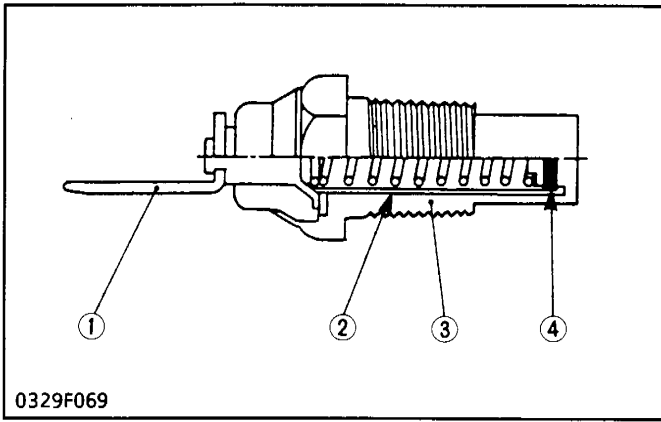

0329F069

- (1) Terminal
- (2) Insulator
- (3) Body
- (4) Thermistor

■ Coolant Temperature Sensor

The coolant temperature sensor is installed to the cylinder head of engine, and its tip is in touch with the coolant. It contains a thermistor (4) whose electrical resistance decreases as the temperature increases.

Current varies with changes in the coolant temperature, and the increases or decreases in the current move the pointer of gauge.

Characteristics of Thermistor	
Temperature	Resistance
50 °C (122 °F)	148.8 Ω
80 °C (176 °F)	50.3 Ω
120 °C (248 °F)	16.0 Ω
170 °C (338 °F)	5.6 Ω

(2) Gauge

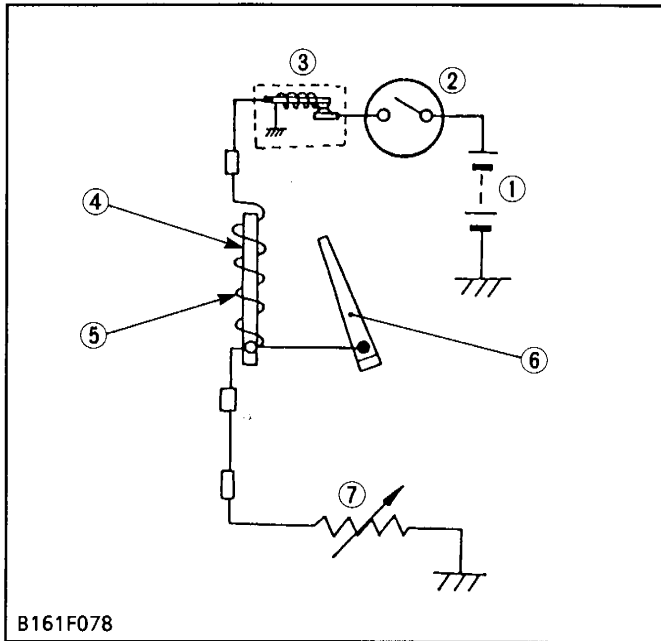

B161F078

Both the fuel gauge and coolant temperature gauge use bimetal types.

When the main switch (2) is turned ON, the current controlled by the resistance of the sensor (7) flows through the circuit and is grounded.

This current heats the heat wire (5), causing the bimetal (4) to deflect in proportion to the current, thereby swinging the indicating needle (6) connected to the bimetal (4).

When the main switch (2) is turned OFF, the indicating needle (6) returns to its original position.

The voltage regulator (3) is installed so as to prevent errors due to voltage fluctuation.

- (1) Battery
- (2) Main Switch
- (3) Voltage Regulator
- (4) Bimetal
- (5) Heat Wire
- (6) Indicating Needle
- (7) Sensor



# SERVICING

## CONTENTS

<b>TROUBLESHOOTING</b> .....	9-S1
<b>SERVICING SPECIFICATIONS</b> .....	9-S4
<b>CHECKING, DISASSEMBLING AND SERVICING</b> .....	9-S5
<b>[1] BATTERY</b> .....	9-S5
CHECKING .....	9-S5
SERVICING .....	9-S7
<b>[2] STARTING SYSTEM</b> .....	9-S8
CHECKING .....	9-S8
DISASSEMBLING AND ASSEMBLING .....	9-S12
SERVICING .....	9-S12
<b>[3] ENGINE KEY SWITCH SHUT-OFF SYSTEM</b> .....	9-S15
CHECKING .....	9-S15
<b>[4] CHARGING SYSTEM</b> .....	9-S17
CHECKING .....	9-S17
DISASSEMBLING AND ASSEMBLING .....	9-S18
SERVICING .....	9-S20
<b>[5] LIGHTING SYSTEM</b> .....	9-S21
CHECKING .....	9-S21
<b>[6] WARNING LAMPS</b> .....	9-S24
CHECKING .....	9-S24
<b>[7] GAUGES</b> .....	9-S27
CHECKING .....	9-S27





## TROUBLESHOOTING

Symptom	Probable Cause	Solution	Reference Page
All Electrical Equipments Do Not Operate	● Battery discharged or defective	Recharge or replace	9-S5 to S7
	● Battery positive cable disconnected or improperly connected	Repair or replace	9-S5
	● Battery negative cable disconnected or improperly connected	Repair or replace	9-S5
	● Slow blow fuse blown	Replace	–
Fuse Blown Frequently	● Short-circuited	Repair or replace	–

### BATTERY

Battery Discharges Too Quickly	● Battery defective	Recharge or replace	9-S5 to S7
	● Alternator defective	Repair or replace	9-S17 to S21
	● Wiring harness disconnected or improperly connected (between battery positive terminal and alternator B terminal)	Repair or replace	9-M1, M2
	● Cooling fan belt slipping	Adjust tension	–

### STARTING SYSTEM

Starter Motor Does Not Operate	● Battery discharged or defective	Recharge or replace	9-S5 to S7
	● Slow blow fuse blown	Replace	–
	● Starter relay defective	Replace	9-S9
	● Shuttle limit switch improperly adjusted or defective	Repair or replace	9-S9
	● PTO limit switch improperly adjusted or defective	Repair or replace	9-S9
	● Wiring harness disconnected or improperly connected (between main switch ST terminal and PTO limit switch, between PTO limit switch and shuttle limit switch, between shuttle limit switch and starter relay, between starter relay and ground, between main switch B terminal and starter relay, between starter relay and starter motor S terminal, between battery positive terminal and starter motor B terminal)	Repair or replace	9-M1, M2
Glow Lamp Does Not Light	● Starter motor defective	Repair or replace	9-S11 to S14
	● Main switch defective	Replace	9-S8, S9
	● Fuse blown (10 A)	Replace	–
Glow Lamp Does Not Light	● Water temperature sensor defective	Replace	9-S10
	● Glow relay defective	Replace	9-S10
	● Glow controller defective	Replace	9-S10
	● Bulb blown	Replace	–
	● Main switch defective	Replace	9-S8, S9
	● Circuit in panel board defective	Replace	–
	● Wiring harness disconnected or improperly connected (between main switch AC terminal and panel board, between panel board and glow controller, between glow controller and ground)	Repair or replace	9-M1, M2

**ENGINE KEY SWITCH SHUT-OFF SYSTEM**

Symptom	Probable Cause	Solution	Reference Page
Engine Does Not Stop When Main Switch Is Turned OFF	<ul style="list-style-type: none"> <li>● Fuse blown (15 A)</li> <li>● Timer relay defective</li> <li>● Wiring harness disconnected or improperly connected (between main switch B terminal and timer relay 4 terminal, between timer relay 1 terminal and fuel cut off solenoid)</li> <li>● Fuel cut off solenoid defective</li> </ul>	Replace Replace Repair or replace	– 9-S15 9-M1, M2
		Replace	9-S16
Engine Does Not Start	<ul style="list-style-type: none"> <li>● Timer relay defective</li> <li>● Fuel cut off solenoid defective</li> </ul>	Replace Replace	9-S15 9-S16

**CHARGING SYSTEM**

Charging Lamp Does Not Light When Main Switch Is Turned ON	<ul style="list-style-type: none"> <li>● Fuse blown (10 A)</li> <li>● Wiring harness disconnected or improperly connected (between main switch AC terminal and panel board, between panel board and alternator L terminal)</li> </ul>	Replace Repair or replace	– 9-M1, M2
Charging Lamp Does Not Go OFF When Engine Is Running	<ul style="list-style-type: none"> <li>● Short circuit between alternator L terminal lead and chassis</li> <li>● Alternator defective</li> </ul>	Repair or replace	9-M1, M2
		Repair or replace	9-S17 to S21

**LIGHTING SYSTEM**

Head Light Does Not Light	<ul style="list-style-type: none"> <li>● Fuse blown (15A)</li> <li>● Bulb blown</li> <li>● Wiring harness disconnected or improperly connected (between main switch AC terminal and combination switch B1 terminal, between combination switch 1 terminal and head light, between combination switch 2 terminal and head light)</li> </ul>	Replace Replace Repair or replace	– – 9-M1, M2
Illumination Light Does Not Light	<ul style="list-style-type: none"> <li>● Fuse blown (15A)</li> <li>● Bulb blown</li> <li>● Wiring harness disconnected or improperly connected (between combination switch T terminal and panel board)</li> </ul>	Replace Replace Repair or replace	– – 9-M1, M2
Tail Light Does Not Light	<ul style="list-style-type: none"> <li>● Bulb blown</li> <li>● Wiring harness disconnected or improperly connected (between combination switch T terminal and tail light)</li> </ul>	Replace Repair or replace	– 9-M1, M2
Hazard Light Does Not Light	<ul style="list-style-type: none"> <li>● Fuse blown (10 A)</li> <li>● Bulb blown</li> <li>● Wiring harness disconnected or improperly connected (between main switch B terminal and hazard unit, between hazard unit and combination switch B2 terminal, between combination switch R terminal and hazard lights)</li> <li>● Hazard unit defective</li> <li>● Combination switch defective</li> </ul>	Replace Replace Repair or replace	– – 9-M1, M2
		Replace Replace	9-S23, S24 9-S23

**LIGHTING SYSTEM (Continued)**

Symptom	Probable Cause	Solution	Reference Page
Hazard Indicator Lamp Does Not Light	<ul style="list-style-type: none"> <li>● Bulb blown</li> <li>● Wiring harness disconnected or improperly connected (between combination switch R terminal and panel board)</li> </ul>	Replace Repair or replace	– 9-M1, M2
Hazard Light Does Not Go ON and OFF	<ul style="list-style-type: none"> <li>● Hazard unit defective</li> </ul>	Replace	9-S23, S24

**EASY CHECKER**

Air Cleaner Clogged Lamp Lights Up	<ul style="list-style-type: none"> <li>● Air cleaner clogged</li> <li>● Air cleaner sensor defective</li> <li>● Short circuit between air cleaner sensor lead and chassis</li> <li>● Circuit in panel board defective</li> </ul>	Clean or replace Replace Repair or replace  Replace	G-17 9-S25 9-M1, M2  –
Air Cleaner Clogged Lamp Does Not Light When Air Cleaner Clogged	<ul style="list-style-type: none"> <li>● Bulb blown</li> <li>● Air cleaner sensor defective</li> <li>● Wiring harness disconnected or improperly connected (between panel board and air cleaner sensor, between air cleaner sensor and ground)</li> </ul>	Replace Replace Repair or replace	– 9-S25 9-M1, M2
Engine Oil Pressure Lamp Lights Up When Engine Is Running	<ul style="list-style-type: none"> <li>● Engine oil pressure too low</li> <li>● Engine oil insufficient</li> <li>● Engine oil pressure switch defective</li> <li>● Short circuit between engine oil pressure switch lead and chassis</li> <li>● Circuit in panel board defective</li> </ul>	Repair engine Replenish Replace Repair  Replace	– G-12 9-S24 9-M1, M2  –
Engine Oil Pressure Lamp Does Not Light When Main Switch Is turned ON and Engine Is Not Running	<ul style="list-style-type: none"> <li>● Bulb blown</li> <li>● Engine oil pressure switch defective</li> <li>● Wiring harness disconnected or improperly connected (between panel board and engine oil pressure switch)</li> <li>● Circuit in panel board defective</li> </ul>	Replace Replace Repair or replace  Replace	– 9-S24 9-M1, M2  –
Parking Brake Lamp Does Not Light When Parking Brake Lever to Parking Position	<ul style="list-style-type: none"> <li>● Bulb blown</li> <li>● Parking brake switch improperly adjusted or defective</li> <li>● Wiring harness disconnected or improperly connected (between panel board and parking brake switch, between parking brake switch and ground)</li> <li>● Circuit in panel board defective</li> </ul>	Replace Repair or replace  Repair or replace  Replace	– 9-S25, S26  9-M1, M2  –
Parking Brake Lamp Does Not Go OFF When Parking Brake Lever Is Released	<ul style="list-style-type: none"> <li>● Short circuit between parking brake switch lead and chassis</li> <li>● Parking brake switch improperly adjusted or defective</li> <li>● Circuit in panel board defective</li> </ul>	Repair or replace  Repair or replace  Replace	9-M1, M2  9-S25, S26  –

**GAUGES**

Symptom	Probable Cause	Solution	Reference Page
<b>Fuel Gauge Does Not Function</b>	<ul style="list-style-type: none"> <li>● Fuel gauge defective</li> <li>● Fuel level sensor (tank unit) defective</li> <li>● Wiring harness disconnected or improperly connected (between panel board and fuel level sensor)</li> <li>● Circuit in panel board defective</li> </ul>	Replace Replace Repair or replace	9-S27 9-S27 9-M1, M2
		Replace	-
<b>Coolant Temperature Gauge Does Not Function</b>	<ul style="list-style-type: none"> <li>● Coolant temperature gauge defective</li> <li>● Coolant temperature sensor defective</li> <li>● Wiring harness disconnected or improperly connected (between panel board and coolant temperature sensor)</li> <li>● Circuit in panel board defective</li> </ul>	Replace Replace Repair or replace	9-S27 9-S27 9-M1, M2
		Replace	-

**SERVICING SPECIFICATIONS****STARTER MOTOR**

Item		Factory Specification	Allowable Limit
Commutator	O.D	30.0 mm 1.181 in.	29.0 mm 1.142 in.
Mica	Undercut	0.50 to 0.80 mm 0.019 to 0.031 in.	0.2 mm 0.008 in.
Brush	Length	15.0 mm 0.591 in.	11.0 mm 0.433 in.

**ALTERNATOR**

Brush	Length	10.5 mm 0.413 in.	8.4 mm 0.331 in.
Slip Ring	O.D.	14.4 mm 0.567 in.	12.8 mm 0.504 in.

# CHECKING, DISASSEMBLING AND SERVICING

## ⚠ CAUTION

- To avoid accidental short circuit, be sure to attach the positive cable to the positive terminal before the ground cable is attached to the negative terminal.

## ■ IMPORTANT

- If the tractor is to be operated for a short time without battery (using a slave battery for starting), do not, under any circumstances, interrupt the circuit by switching off the key switch before stopping the engine by pulling engine stop knob. Use additional current (lights) while engine is running. Insulate terminal of battery. If this advice is disregarded, damage to alternator and regulator may result.

## ■ NOTE

- In this section, when measuring resistance, voltage and amperage, leads of ohmmeter, voltmeter and ammeter are represented by — marks in figure.

## [1] BATTERY

### CHECKING

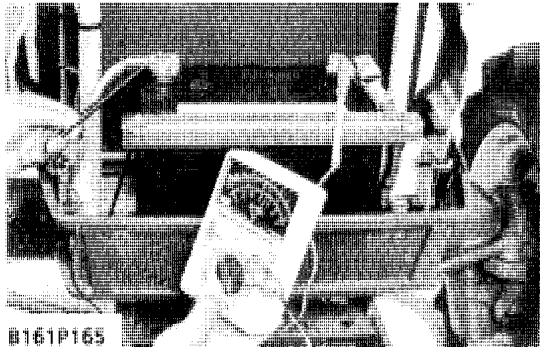

B161P165

#### Battery Voltage

1. Stop the engine and turn the main switch off.
2. Connect the COM (–) lead of the voltmeter to the battery's negative terminal post and the (+) lead to the positive terminal post, and measure the battery voltage.
3. If the battery voltage is less than the factory specifications, check the battery condition. (See the next page.)

Battery voltage	Factory spec.	More than 12 V
-----------------	---------------	----------------

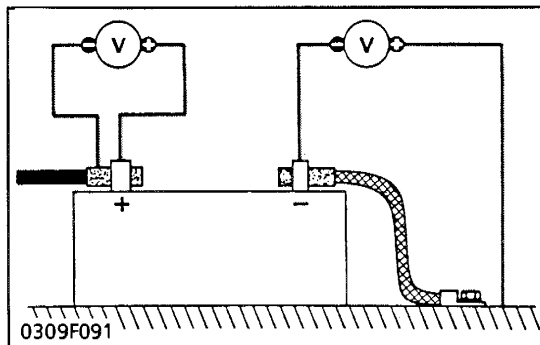

0309F091

#### Battery Terminal Connection

1. Turn the main switch on, and turn on the head light.
2. Measure the voltage with a voltmeter across the battery's positive terminal post and the cable terminal, and the voltage across the battery's negative terminal post and the chassis.
3. If the measurement exceeds the factory specifications, clean the battery terminal posts and cable clamps, and tighten them firmly.

Factory spec.	Less than 0.1 V
---------------	-----------------

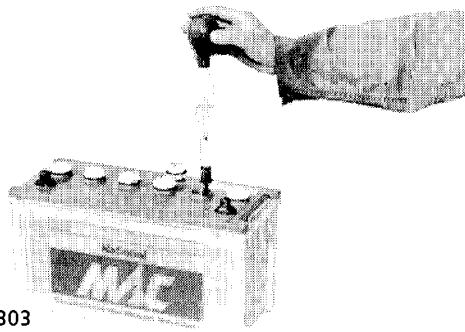

0321P303

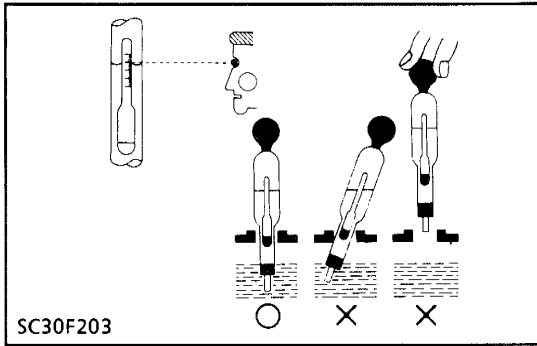

SC30F203

Specific Gravity	State of Charge
1.260 Sp. Gr.	100 % Charged
1.230 Sp. Gr.	75 % Charged
1.200 Sp. Gr.	50 % Charged
1.170 Sp. Gr.	25 % Charged
1.140 Sp. Gr.	Very Little Useful Capacity
1.110 Sp. Gr.	Discharged

At an electrolyte temperature of 20 °C (68 °F)

**Battery Specific Gravity**

**CAUTION**

- Keep electrolyte away from eyes, hands and clothes. If you are splattered with it, wash it away completely with water.
1. Check the specific gravity of the electrolyte in each cell with a hydrometer.
  2. When the electrolyte temperature differs from that at which the hydrometer was calibrated, correct the specific gravity reading following the formula mentioned in (Reference) below.
  3. If the specific gravity is less than 1.215 (after it is corrected for temperature), charge or replace the battery.
  4. If the specific gravity differs between any two cells by more than 0.05, replace the battery.

**NOTE**

- Hold the hydrometer tube vertical without removing it from the electrolyte.
- Do not suck too much electrolyte into the tube.
- Allow the float to move freely and hold the hydrometer at eye level.
- The hydrometer reading must be taken at the highest electrolyte level.

**(Reference)**

- Specific gravity slightly varies with temperature. To be exact, the specific gravity decreases by 0.0007 with an increase of 1 °C (0.0004 with an increase of 1 °F) in temperature, and increases by 0.0007 with a decrease of 1 °C (0.0004 with a decrease of 1 °F).

Therefore, using 20 °C (68 °F) as a reference, the specific gravity reading must be corrected by the following formula :

- Specific gravity at 20 °C = Measured value + 0.0007 × (electrolyte temperature – 20 °C)
- Specific gravity at 68 °F = Measured value + 0.0004 × (electrolyte temperature – 68 °F)

## SERVICING

Tractor Model	Battery Type	Volts (V)	Capacity at 5 H.R. (A.H.)
L3010 L3410	75D26R-MF	12	52
L3710 L4310	75D31R-MF	12	60

Tractor Model	Reserve Capacity (min)	Cold Cranking Amps	Normal Charging Rate (A)
L3010 L3410	123	490	5.2
L3710 L4310	137	447	6.0

### Recharging

#### CAUTION

- When the battery is being activated, hydrogen and oxygen gases in the battery are extremely explosive. Keep open sparks and flames away from the battery at all times, especially when charging the battery.
- When charging battery, remove battery vent plugs.
- When disconnecting the cable from the battery, start with the negative terminal first. When connecting the cable to the battery, start with the positive terminal first.
- Never check battery charge by placing a metal object across the posts.  
Use a voltmeter or hydrometer.

#### 1) Slow Charging

1. Add distilled water if the electrolyte level is low. When charging, the amount of electrolyte should be slightly lower than the specified level to prevent overflow.
2. Connect the battery to the charging unit, following the manufacturer's instructions.
3. As the electrolyte generates gas while charging, remove all port caps.
4. The electrolyte temperature must not exceed 40 °C (105 °F) during charging.  
If it exceed 40 °C (105 °F), decrease the charging amperage or stop charging for a while.
5. When charging several batteries in series, charge at the rate of the smallest battery in the line.

#### 2) Quick Charging

1. Determine the proper charging current and charging time with the tester attached to the quick charger.
2. Determine the proper charging current as 1/1 of the battery capacity. If the battery capacity exceeds 50 Ah, consider 50 A as the maximum.

#### ■ Precaution for Operating a Quick Charger

- Operation with a quick charger differs according to the type. Consult the instruction manual and use accordingly.

### Directions for Storage

1. When shutting down the tractor for long periods of time, remove the battery from the tractor, adjust the electrolyte to the proper level, and after fully charging, store the battery in a well ventilated placed where it is not exposed to direct sunlight.
2. Since the battery self-discharges by approx. 0.5 % per day even in storage, it must be once every two months in cold season.
3. When storing the battery mounted on the tractor, disconnect the ground cable from the battery's negative terminal post.

#### (Reference)

##### Self-discharge Rate

Temperature	Self-discharge rate
30 °C (86 °F)	Approx. 1.0 % per day
20 °C (68 °F)	Approx. 0.5 % per day
10 °C (50 °F)	Approx. 0.25 % per day

## [2] STARTING SYSTEM

### CHECKING

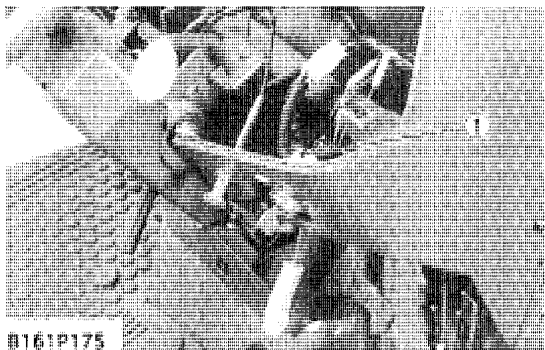

B161P175

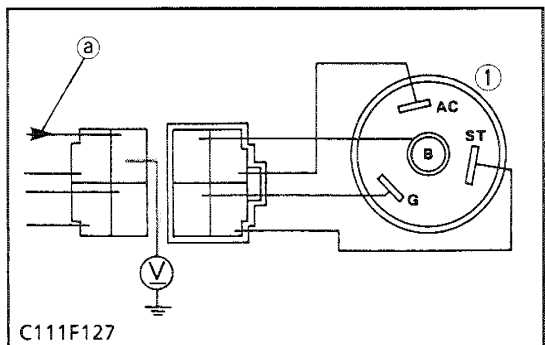

C111F127

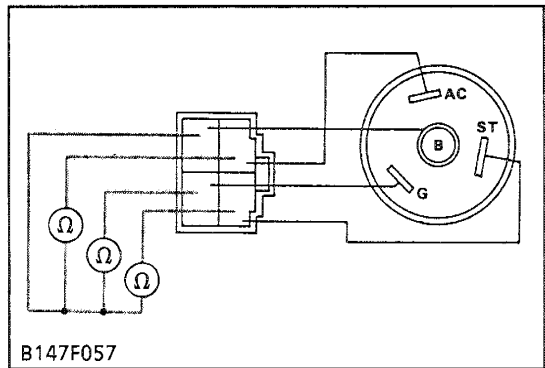

B147F057

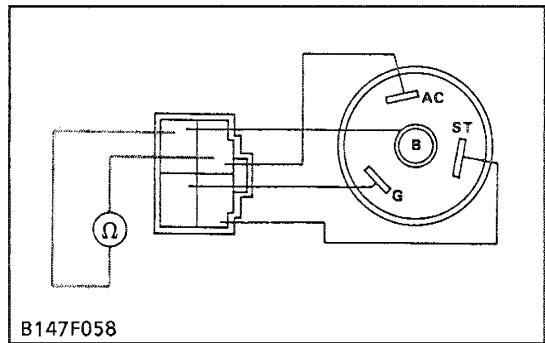

B147F058

#### Main Switch

1. Remove the meter panel, and disconnect the main switch connectors after turning the main switch off.
2. Perform the following checking.

(1) Main Switch

#### Connector Voltage

1. Measure the voltage with a voltmeter across the connector B terminal and chassis.
2. If the voltage differs from the battery voltage (11 to 14 V), the wiring harness is faulty.

Voltage	Connector B terminal – Chassis	Approx. battery voltage
---------	--------------------------------	-------------------------

(a) From Battery Positive Terminal

(1) Main Switch

#### Main Switch Key at OFF Position

1. Turn the main switch off.
2. Measure the resistances with an ohmmeter across the B terminal and the AC terminal, B terminal and ST terminal, and B terminal and G terminal.
3. If infinity is not indicated, the contacts of the main switch are faulty.

Resistance	B terminal – AC terminal	Infinity
	B terminal – ST terminal	Infinity
	B terminal – G terminal	Infinity

#### Main Switch Key at ON Position

1. Turn the main switch on.
2. Measure the resistances with an ohmmeter across the B terminal and the AC terminal.
3. If 0 ohm is not indicated, the B – AC contacts of the main switch are faulty.

Resistance	B terminal – AC terminal	0 ohm
------------	--------------------------	-------



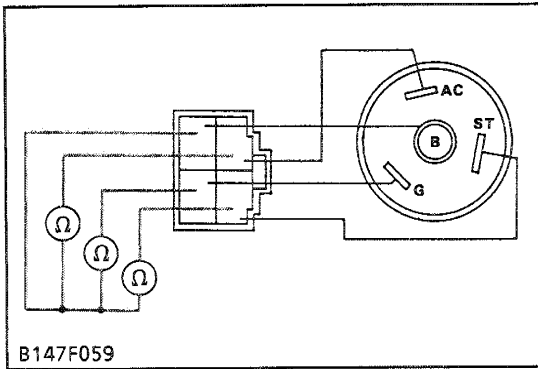

**Main Switch Key at START Position**

1. Turn and hold the main switch key at the **START** position.
2. Measure the resistances with an ohmmeter across the **B** terminal and the **G** terminal, across the **B** terminal and the **ST** terminal and across the **B** terminal and the **AC** terminal.
3. If 0 ohm is not indicated, these contacts of the main switch are faulty.

Resistance	B terminal – G terminal	0 ohm
	B terminal – ST terminal	0 ohm
	B terminal – AC terminal	0 ohm



**Check for Mismatching of the Shuttle and PTO Limit Switches**

1. Disconnect the leads from shuttle and PTO limit switches.
2. Measure the resistance with an ohmmeter across the limit switch wiring lead and lead.
3. If the ohmmeter reads 0 ohm when the shift lever is in neutral, and infinity when the lever is in other positions, it is an indication that the switch is normal.

(1) Shuttle Limit Switch

(2) PTO Limit Switch

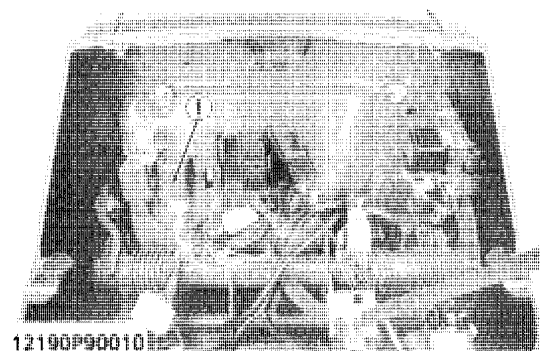
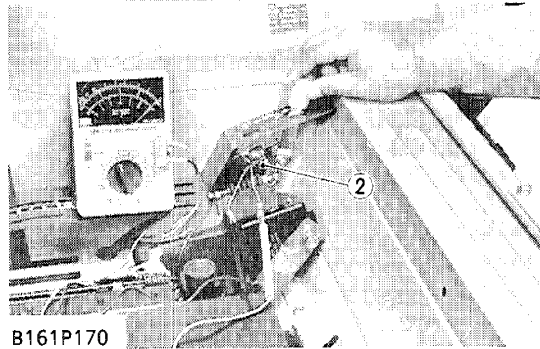

**Checking Starter Relay**

1. Remove the starter relay (1).
2. Apply battery voltage across terminals 2 and 4, and check for continuity across terminals 1 and 3.
3. If continuity is not established across terminals 1 and 3, renew the starter relay.

(1) Starter Relay

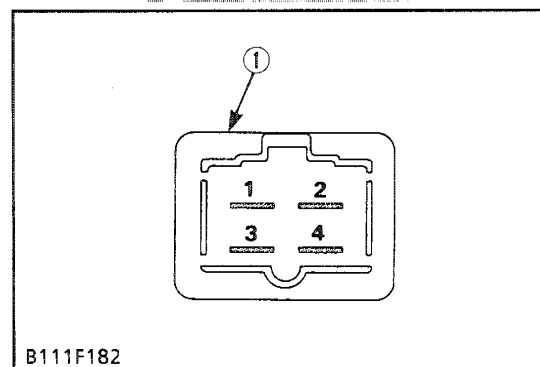

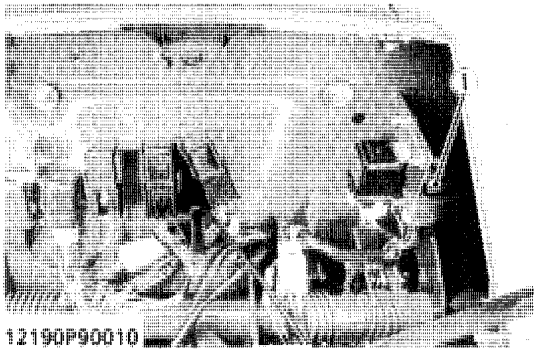

12190P90010

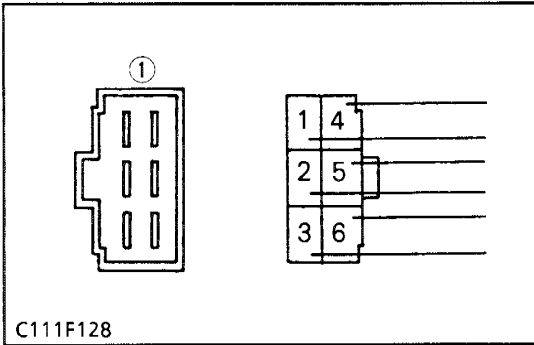

**Glow Controller**

1. Turn the main switch off.
2. Disconnect the connector from glow controller (1).
3. Check the following using the 6P connector of the wire harness.
4. In cases where all the inspection results are correct but the glow controller does not operate normally, replace the glow controller.

**1) Main Switch ON Position**

1. Turn the main switch on.
2. Measure the voltage across the terminal 4 and terminal 5 of the wiring harness or the terminal 2 and chassis.
3. The battery is normal if the voltage is 11 to 14 volts. If faulty, inspect the main switch, easy checker, glow relay, and wiring harness.

**2) Main Switch Starting Position**

1. Hold the main switch at the starting position.
2. Measure the voltage across the terminal 6 and chassis.
3. The battery is normal if the voltage is 11 to 14 volts. If the voltage is not in this range, inspect the main switch and wiring harness.

(1) Glow Controller

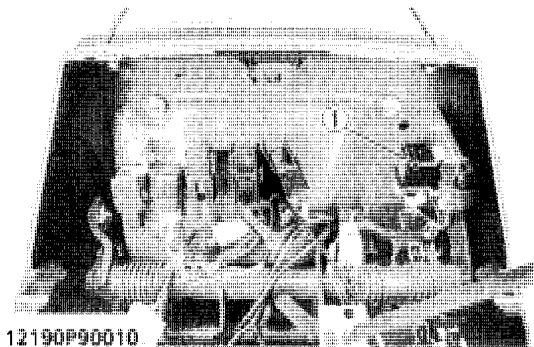

12190P90010

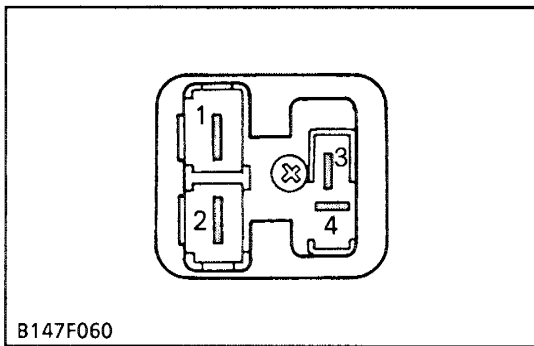

**Glow Relay**

**1) Connector Voltage**

1. Turn the main switch off.
2. Disconnect the 1P connectors and 2P connector from glow relay (1).
3. Measure the voltage with a voltmeter across the 1P connector R terminal (Positive) and chassis (Negative).
4. If the voltage differs from the battery voltage, the wiring harness is faulty.
5. Turn the main switch on.
6. Measure the voltage with a voltmeter across the 2P connector RW terminal (Positive) and chassis (Negative).
7. If the voltage differs from the battery voltage, the wiring harness is faulty.

**2) Glow Relay Test**

1. Remove the glow relay (1).
2. Apply battery voltage across terminals 3 and 4, and check for continuity across terminals 1 and 2.
3. If continuity is not established across terminals 1 and 2, replace the glow relay (1).

(1) Glow Relay

**Water Temperature Sensor Continuity**

1. Disconnect the connector from the water temperature sensor.
2. Measure the resistance with an ohmmeter.
3. If the measurement is not indicated, the sensor is faulty.

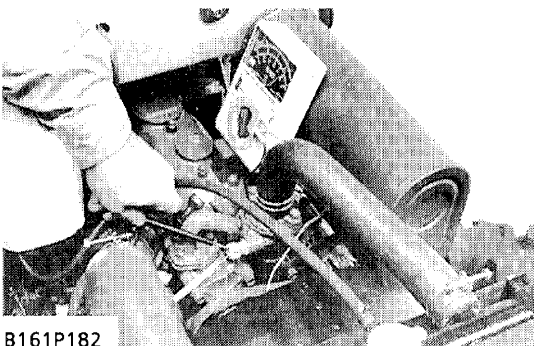

B161P182

Resistance	Reference value	Approx. 16.2 kΩ at -20 °C (-4 °F) Approx. 3.88 kΩ at 0 °C (32 °F) Approx. 2.45 kΩ at 20 °C (68 °F) Approx. 1.14 kΩ at 40 °C (104 °F) Approx. 0.58 kΩ at 60 °C (140 °F) Approx. 0.32 kΩ at 80 °C (176 °F)

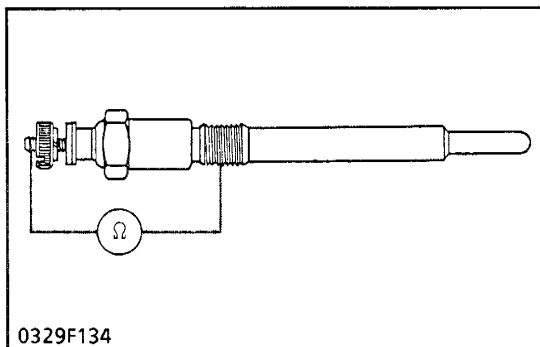

**Glow Plug**

1. Disconnect the leads from the glow plugs.
2. Measure the resistance with an ohmmeter across the glow plug terminal and chassis.
3. If 0 ohm is indicated, the screw at the tip of the glow plug and the housing are short-circuited.
4. If the factory specification is not indicated, the glow plug is faulty.

Glow plug resistance	Factory spec.	Approx. 0.5 ohms
----------------------	---------------	------------------

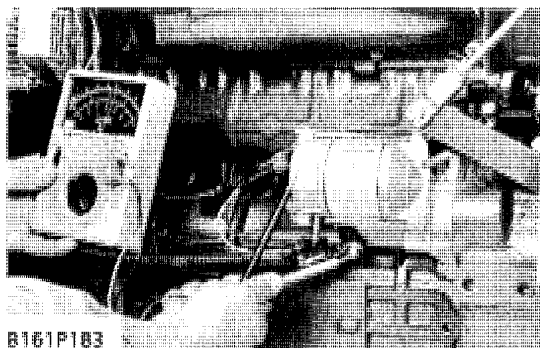

**Starter Motor B Terminal Voltage**

1. Measure the voltage with a voltmeter across the B terminal and chassis.
2. If the voltage differs from the battery voltage, the battery's positive cable or the battery negative cable is faulty.

Voltage	B terminal – chassis	Approx. battery voltage
---------	----------------------	-------------------------

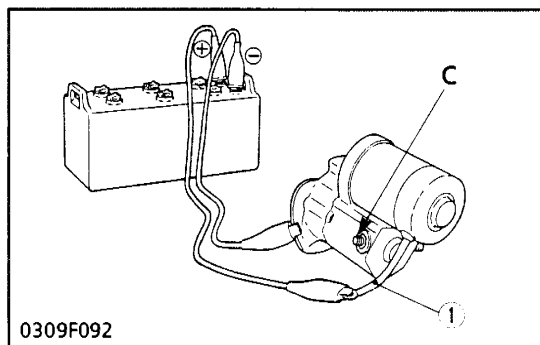

(1) Connecting Lead

**Motor Test**

**⚠ CAUTION**

- Secure the starter in a vise to prevent it from jumping up and down while testing the motor.

1. Disconnect the ground cable clamp from the battery negative terminal post.
2. Disconnect the battery positive cable and the leads from the starter.
3. Remove the starter motor from the engine.
4. Disconnect the connecting lead (1) from the starter C terminal.
5. Connect a jumper lead from the connecting lead (1) to the battery positive terminal post.
6. Connect a jumper lead momentarily between the starter motor housing and the battery negative terminal post.
7. If the motor does not run, check the motor.

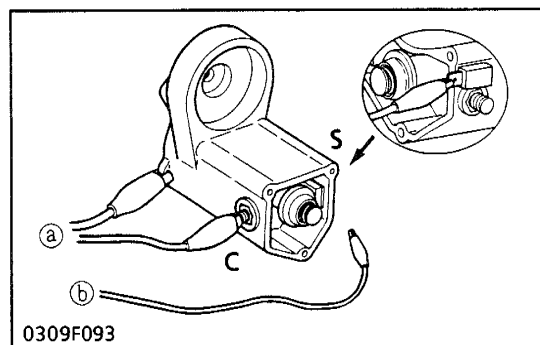

(a) To Negative Terminal (b) To Positive Terminal

**Magnet Switch Test (Pull-in, Holding Coils)**

1. Remove the motor from the starter housing.
2. Prepare a 6 V battery for the test.
3. Connect jumper leads from the battery negative terminal to the housing and the starter C terminal.
4. The plunger should be attached and the pinion gear should pop out when a jumper lead is connected from the battery positive terminal to the S terminal. It's correct.
5. Disconnect the jumper lead to the starter C terminal. Then the pinion gear should remain popped out. It's correct.

**■ IMPORTANT**

- Testing time must be 3 to 5 sec.

## DISASSEMBLING AND ASSEMBLING

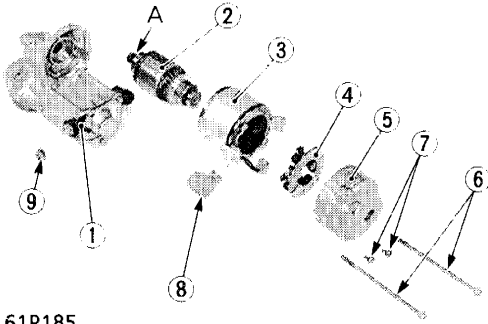

B161P185

### Disassembling Motor

1. Disconnect the connecting lead (8) from the magnet switch (1).
2. Remove the through screws (6), and then separate the end frame (5), yoke (3) and armature (2).
3. Remove the two screws (7), and then take out the brush holder (4) from the end frame (5).

### (When reassembling)

- Apply grease to the spline teeth (A) of the armature (2).

### [A] Spline Teeth

- |                   |                     |
|-------------------|---------------------|
| (1) Magnet Switch | (6) Screws          |
| (2) Armature      | (7) Screws          |
| (3) Yoke          | (8) Connecting Lead |
| (4) Brush Holder  | (9) Nut             |
| (5) End Frame     |                     |

### Disassembling Magnet Switch

1. Remove the drive end frame (1) mounting screws.
2. Take out the over running clutch (2), ball (3), spring (4), gear (5), rollers (6) and retainer (7).

### (When reassembling)

- Apply grease to the gear teeth of the gear (5) and over running clutch (2), and ball (3).

- |                         |              |
|-------------------------|--------------|
| (1) Drive End Frame     | (5) Gear     |
| (2) Over Running Clutch | (6) Rollers  |
| (3) Ball                | (7) Retainer |
| (4) Spring              |              |

### Plunger

1. Remove the end cover (1).
2. Take out the plunger (2).

- |               |             |
|---------------|-------------|
| (1) End Cover | (2) Plunger |
|---------------|-------------|

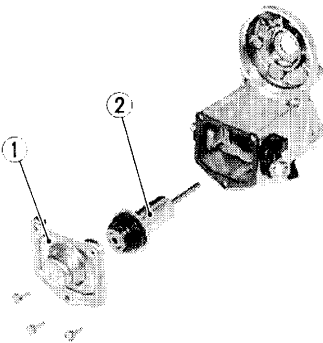

B161P187

## SERVICING

### Bearing and Clutch

1. Check the bearing and the clutch for smooth rotation.  
The clutch should engage and rotate with the pinion shaft in the forward driving direction and disengage in reverse.

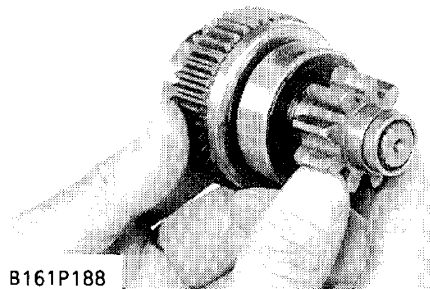

B161P188

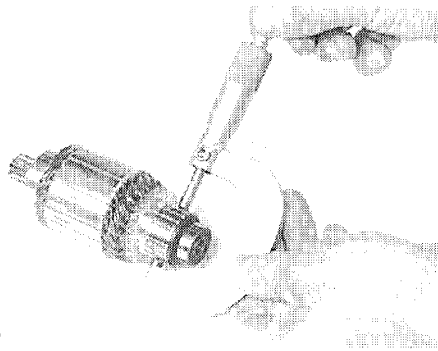

**Commutator and Mica**

1. If the commutator surface is dirty or dusty, clean it with sandpaper.
2. Measure the commutator O.D. with an outside micrometer at several points.
3. If the minimum O.D. is less than the allowable limit, replace the armature.
4. If the difference of the outer diameters exceeds the allowable limit, use a lathe to adjust the outer diameter to within the allowable limit.
5. Measure the mica undercut.
6. If the undercut is less than the allowable limit, correct it with a saw blade and chamfer the segment edges.

B161P189

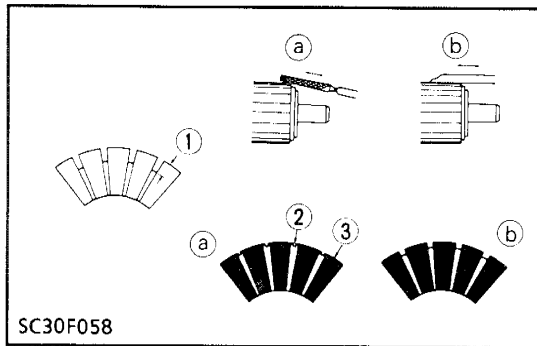

(a) Incorrect (b) Correct  
 (1) Undercut (2) Mica (3) Segment

Commutator O.D.	Factory spec.	30.0 mm 1.181 in.
	Allowable limit	29.0 mm 1.142 in.

Difference of max. O.D. and min. O.D.	Factory spec.	Less than 0.02 mm 0.0008 in.
	Allowable limit	0.05 mm 0.0020 in.

Mica undercut	Factory spec.	0.50 to 0.80 mm 0.019 to 0.031 in.
	Allowable limit	0.2 mm 0.008 in.

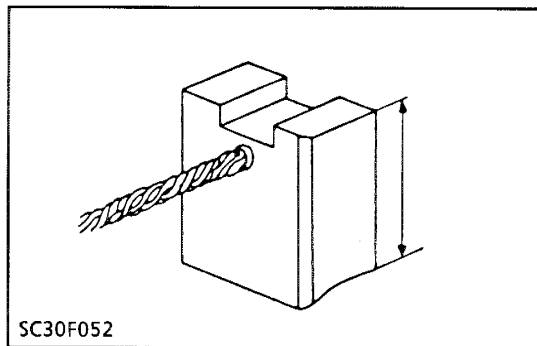

SC30F052

**Brush Wear**

1. If the contact face of the brush is dirty or dusty, clean it with sandpaper.
2. Measure the brush length.
3. If the length is less than the allowable limit, replace it.

Brush length	Factory spec.	15.0 mm 0.591 in.
	Allowable limit	11.0 mm 0.433 in.

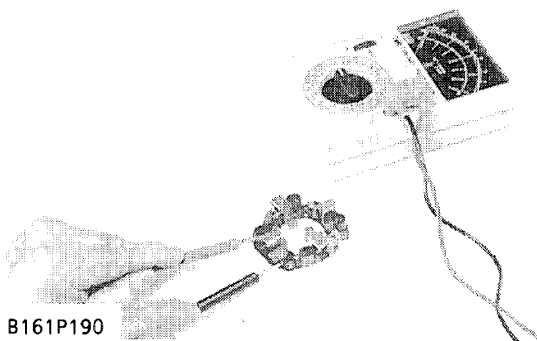

B161P190

**Brush Holder**

1. Measure the resistance with an ohmmeter across the brush holder and the holder support.
2. If infinity is not indicated, replace them as a unit.

Resistance	Brush holder – Holder support	Infinity
------------	-------------------------------	----------

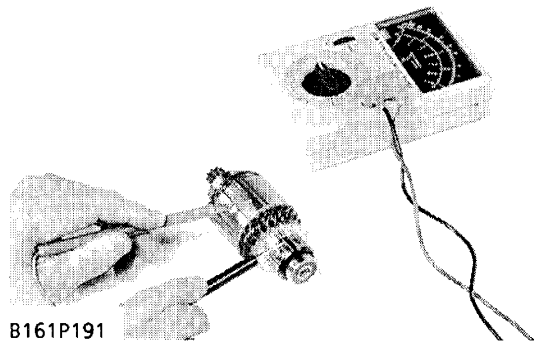

B161P191

**Armature Coil**

1. Measure the resistance with an ohmmeter across the commutator and the armature shaft.
2. If infinity is not indicate, replace them as a unit.

Resistance	Commutator – Armature	Infinity
------------	-----------------------	----------

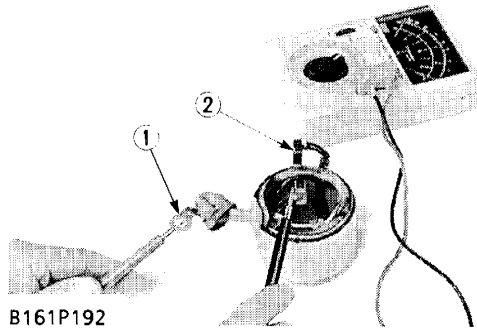

B161P192

**Field Coil**

1. Measure the resistance with an ohmmeter across the connecting lead (1) and the brush (2).
2. If 0 ohm is not indicated, replace them as a unit.
3. Measure the resistance with an ohmmeter across the brush (2) and the yoke (3).
4. If infinity is not indicated, replace them as a unit.

Resistance	Connecting lead – Brush	0 ohm
	Brush – Yoke	Infinity

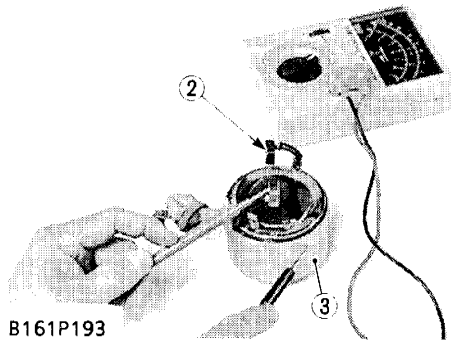

B161P193

- (1) Connecting Lead
- (2) Brush

- (3) Yoke

### [3] ENGINE KEY SWITCH SHUT-OFF SYSTEM

#### CHECKING

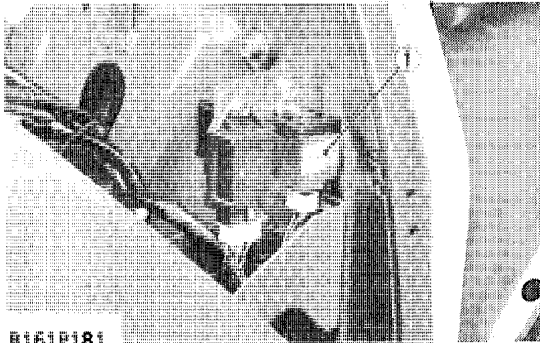

B161F181

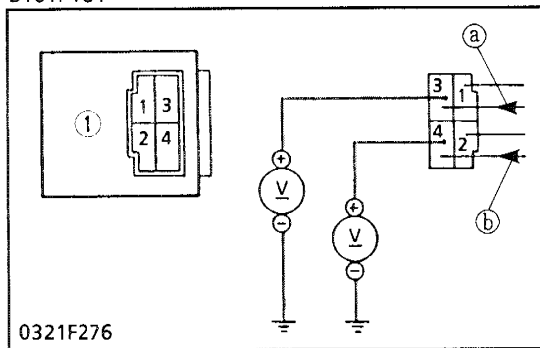

0321F276

#### Timer Relay Connector Voltage

1. Disconnect the connector from the timer relay after turning the main switch off.
2. Measure the voltage with a voltmeter across the connector 4 terminal and chassis.
3. Turn the main switch on, and measure the voltage across the connector 3 terminal and chassis.
4. If these voltages differ from the battery voltage, the wiring harness or main switch is faulty.

Voltage	Connector 4 terminal – chassis	Approx. battery voltage
	Connector 3 terminal – chassis	Approx. battery voltage

- (a) From Main Switch AC Terminal      (b) From Battery Positive Terminal

(1) Timer Relay

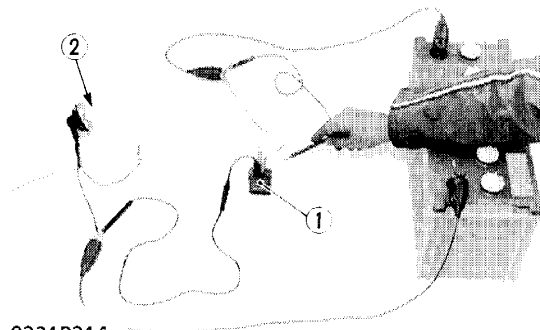

0321P314

#### Test of Timer Relay

1. Remove the timer relay from the tractor.
2. Connect jumper leads across the battery positive terminal and the timer relay 3 terminal, and across the battery positive terminal and the timer relay 4 terminal.
3. Connect jumper leads across the battery negative terminal and the timer relay 2 terminal, and across the battery negative terminal and the bulb terminal.
4. Connect jumper lead across the timer relay 1 terminal and the bulb terminal.
5. The bulb lights up when disconnecting a jumper lead from the 3 terminal and goes off 6 to 13 seconds later, the timer relay is proper.

- (1) Timer Relay  
(2) Load (Lamp)

(3) Battery (12 V)

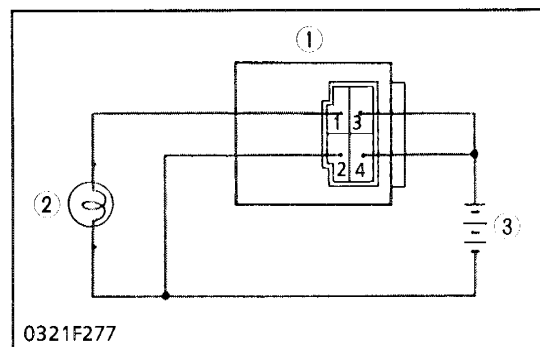

0321F277

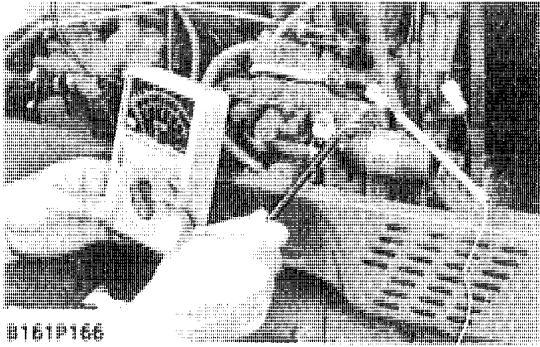

B161P166

**Fuel Cut Off Solenoid Lead Terminal Voltage**

1. Disconnect the lead from the fuel cut off solenoid after turning the main switch off.
2. Turn the main switch **ON**.
3. Measure the voltage with a voltmeter across the lead terminal and the chassis just when the main switch is turned off.
4. If the battery voltage is not indicated for a certain seconds, check the wiring harness, the main switch, the timer relay, a fuse and the alternator.

Voltage	Across lead terminal and chassis when main switch turned off	Approx. battery voltage
---------	--	-------------------------

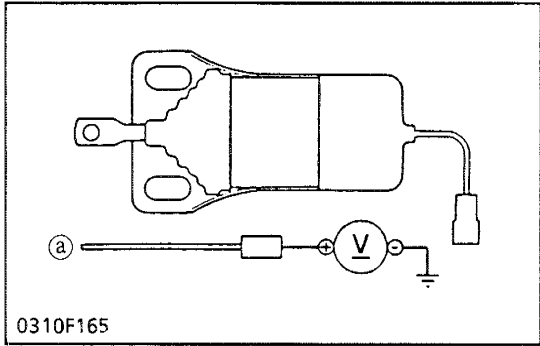

0310F165

(a) To Timer Relay



B161P167

**Fuel Cut Off Solenoid Test**

1. Disconnect the lead from the fuel cut off solenoid after turning the main switch off.
2. Connect jumper leads from the battery positive terminal to the fuel cut off solenoid lead terminal.
3. If the solenoid plunger is not attracted, the fuel cut off solenoid is faulty.

(1) Battery (12 V)

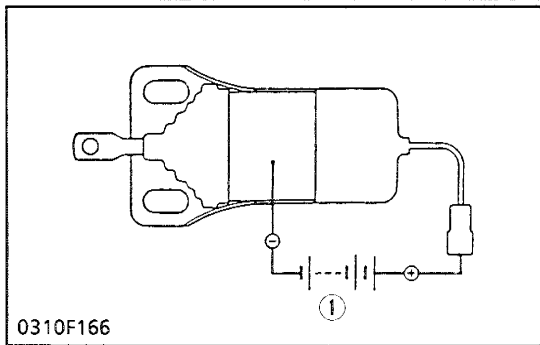

0310F166



## [4] CHARGING SYSTEM

### CHECKING

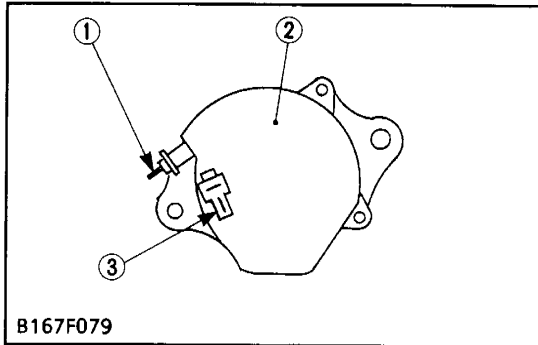

#### Alternator

1. Disconnect the 2P connector (3) from alternator after turning the main switch OFF.
2. Perform the following checkings.

- (1) B Terminal (3) 2P Connector  
 (2) Alternator

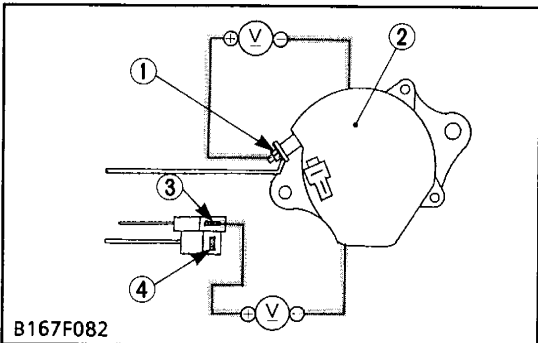

#### Connector Voltage

1. Turn the main switch OFF. Measure the voltage across the B terminal (1) and chassis.
2. Turn the main switch ON. Measure the voltage across the IG terminal (3) and chassis.

Voltage (Main switch at OFF)	B terminal – Chassis	Approx. battery voltage
Voltage (Main switch at ON)	IG terminal lead – Chassis	Approx. battery voltage

- (1) B Terminal (3) IG Terminal  
 (2) Alternator (4) L Terminal

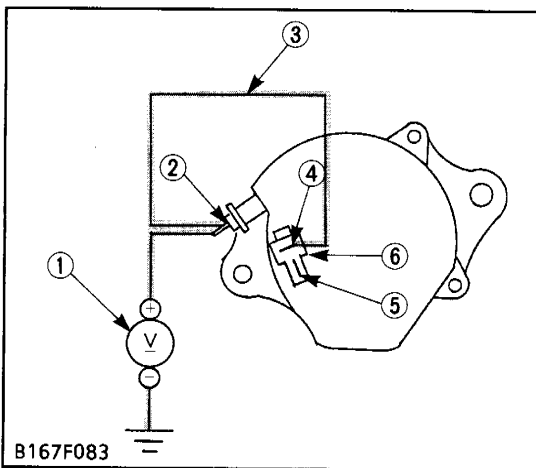

#### No-Load Test

1. Connect the 2P connector (6) to previous positions of the alternator after turning the main switch OFF.
2. Connect the jumper lead (3) between IG terminal (4) and B terminal (2).
3. Start the engine and then set the idling speed.
4. Disconnect the negative cable from the battery.
5. Measure the voltage across the B terminal (2) and the chassis.
6. If the measurement is less than the factory specification, disassemble the alternator and check the IC regulator.

Voltage	B terminal – Chassis	More than 14 V
---------	----------------------	----------------

- (1) Voltmeter (4) IG Terminal  
 (2) B Terminal (5) L Terminal  
 (3) Jumper Lead (6) 2P Connector

#### (Reference)

- Once the engine has started, the alternator temperature rose quickly up to an ambient temperature of 70 to 90 °C (158 to 194 °F). As the temperature goes higher than 50 °C (122 °F), the alternator voltage slowly drops; at higher than 100 °C (212 °F), it drops by about 1 V.

## DISASSEMBLING AND ASSEMBLING

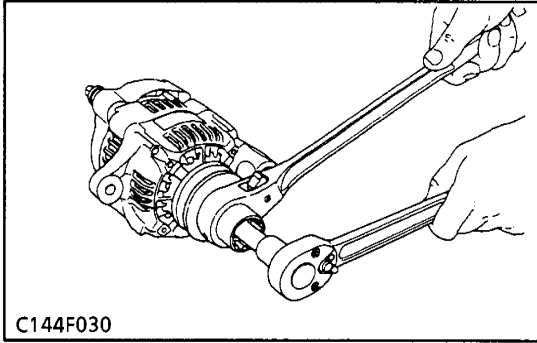

C144F030

### Pulley

1. Secure the hexagonal end of the pulley shaft with a double-ended ratchet wrench as shown in the figure, loosen the nut with a socket wrench and remove it.

Tightening torque	Pulley lock nut	58.3 to 78.9 N·m 5.95 to 8.05 kgf·m 43.0 to 58.2 ft·lbs
-------------------	-----------------	---

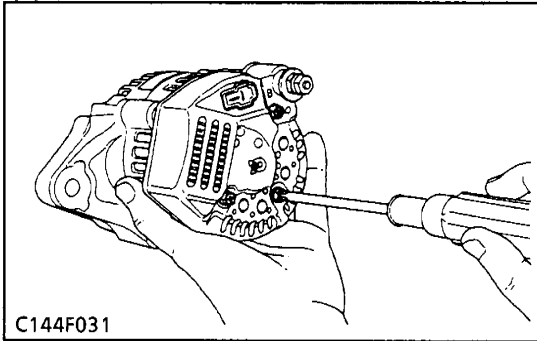

C144F031

### Rear End Cover

1. Unscrew the three rear end cover screws and the terminal B nut and remove the rear end cover.

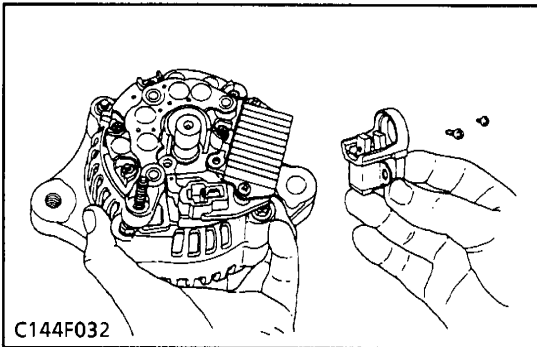

C144F032

### Brush Holder

1. Unscrew the two screws holding the brush holder and remove the brush holder.

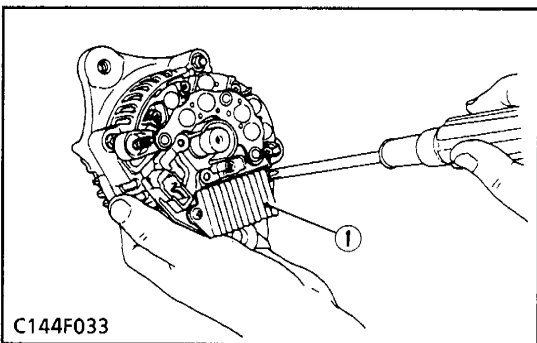

C144F033

### IC Regulator

1. Unscrew the three screws holding the IC regulator (1) and remove it.

(1) IC Regulator

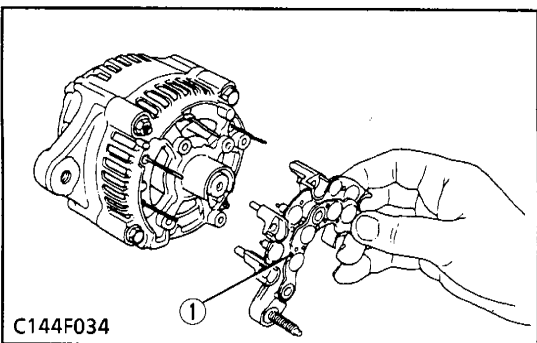

C144F034

### Rectifier

1. Remove the four screws holding the rectifier (1) and the stator lead wires.

(1) Rectifier

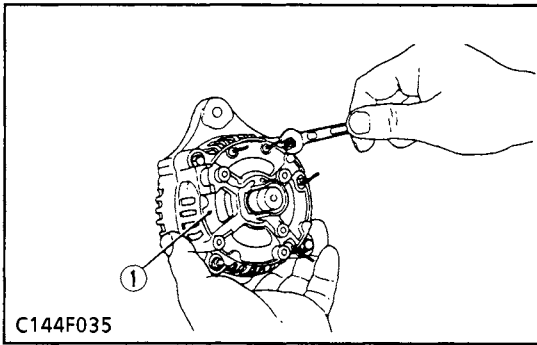

**Rear End Frame**

1. Remove the two nuts and two screws holding the drive end frame and the rear end frame.
2. Remove the rear end frame (1).

(1) Rear End Frame

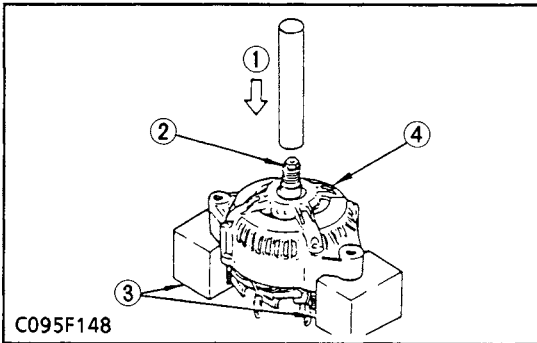

**Rotor**

1. Press out the rotor (2) from drive end frame (4).

**■ IMPORTANT**

- Take special care not to drop the rotor and damage the slip ring or fan, etc.

(1) Press  
(2) Rotor

(3) Block  
(4) Drive End Frame

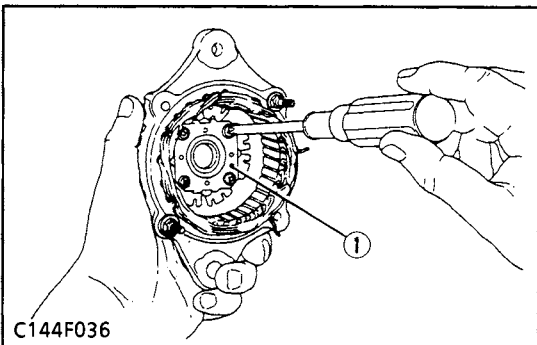

**Retainer Plate**

1. Remove the screws holding the retainer plate and remove the retainer plate (1).

(1) Retainer Plate

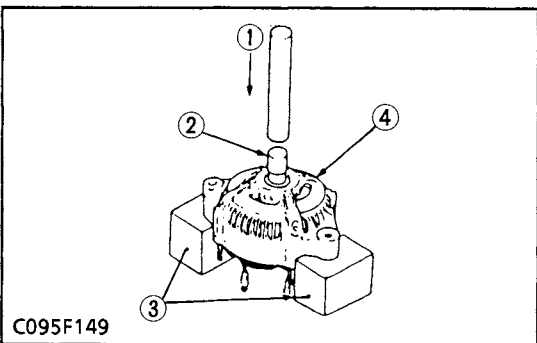

**Bearing on the Drive End Side**

1. Press out the bearing from drive end frame (4) using with press (1) and jig (2).

(1) Press  
(2) Jig

(3) Block  
(4) Drive End Frame

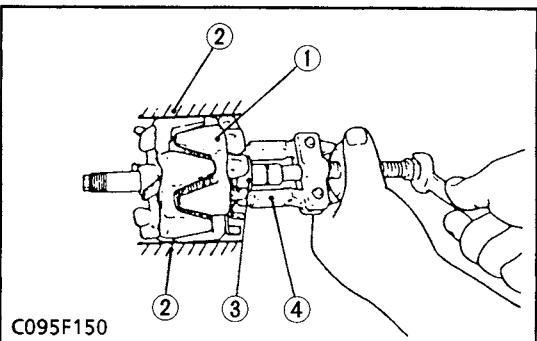

**Bearing at the Slip Ring Side**

1. Lightly secure the rotor (1) with a vise (2) to prevent damage and remove the bearing using with puller (4).

(1) Rotor  
(2) Vise

(3) Bearing  
(4) Puller

## SERVICING

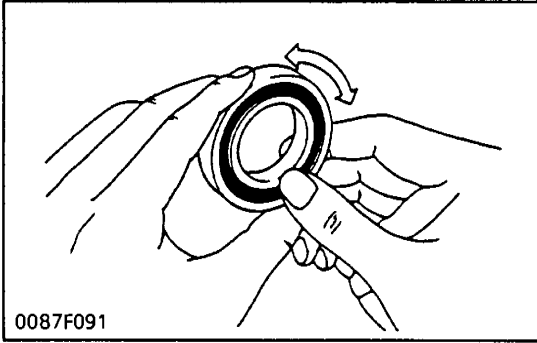

0087F091

### Bearing

1. Check the bearing for smooth rotation.
2. If it does not rotate smoothly, replace it.

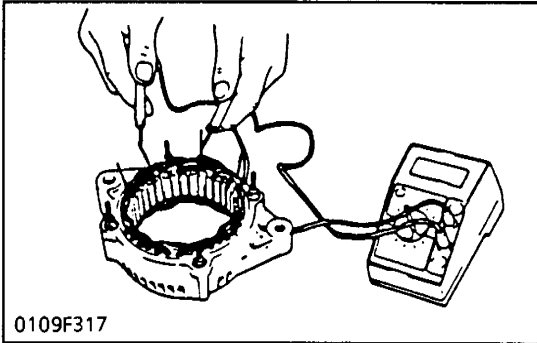

0109F317

### Stator

1. Measure the resistance with an ohmmeter across each lead of the stator coil.
2. If the measurement is not within factory specification, replace it.
3. Check the continuity across each stator coil lead and core with an ohmmeter.
4. If infinity is not indicated, replace it.

Resistance	Factory spec.	Less than 1.0 ohms
------------	---------------	--------------------

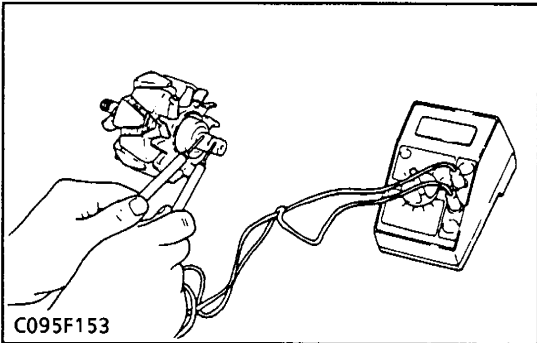

C095F153

### Rotor

1. Measure the resistance across the slip rings.
2. If the resistance is not the factory specification, replace it.
3. Check the continuity across the slip ring and core with an ohmmeter.
4. If infinity is not indicated, replace it.

Resistance	Factory spec.	2.9 ohms
------------	---------------	----------

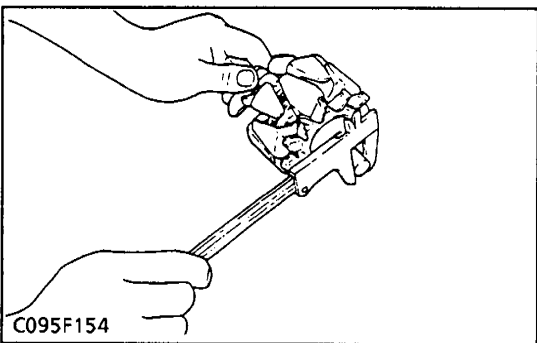

C095F154

### Slip Ring

1. Check the slip ring for score.
2. If scored, correct with an sand paper or on a lathe.
3. Measure the outside diameter of slip ring with a vernier caliper.
4. If the measurement exceeds the allowable limit, replace it.

Slip ring O.D.	Factory spec.	14.4 mm 0.567 in.
	Allowable limit	12.8 mm 0.504 in.

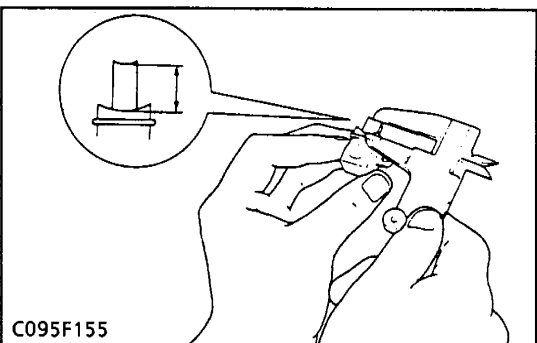

C095F155

### Brush Wear

1. Measure the length of brush with a vernier caliper.
2. If the measurement is less than allowable limit, replace it.
3. Make sure that the brush moves smoothly.
4. If the brush is defective, replace it.

Brush length	Factory spec.	10.5 mm 0.413 in.
	Allowable limit	8.4 mm 0.331 in.

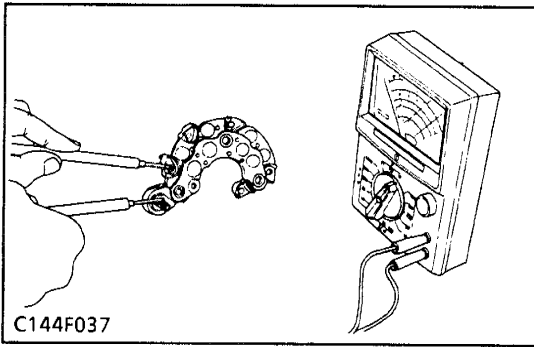

### Rectifier

1. Check the continuity across each diode of rectifier with an analog ohmmeter. Conduct the test in the (R × 1) setting.
2. The rectifier is normal if the diode in the rectifier conducts in one direction and does not conduct in the reverse direction.

#### ■ IMPORTANT

- Do not use a 500 V megger for measuring because it will destroy the rectifier.

#### ■ NOTE

- Do not use an auto digital multimeter. Because it's very hard to check the continuity of rectifier by using it.

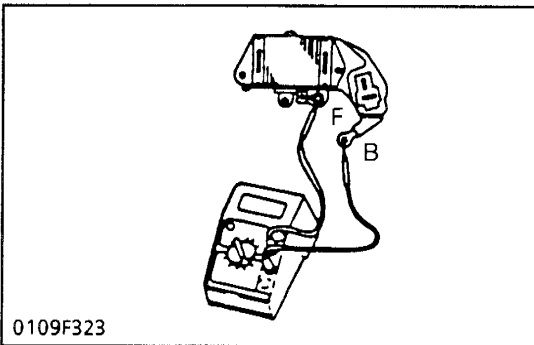

### IC Regulator

1. Check the continuity across the B terminal and the F terminal of IC regulator with an analog ohmmeter. Conduct the test in the (R × 1) setting.
2. The IC regulator is normal if the IC regulator conducts in one direction and does not conduct in the reverse direction.

#### ■ IMPORTANT

- Do not use a 500 V megger for measuring because it will destroy the IC regulator.

#### ■ NOTE

- Do not use an auto digital multimeter. Because it's very hard to check the continuity of IC regulator by using it.

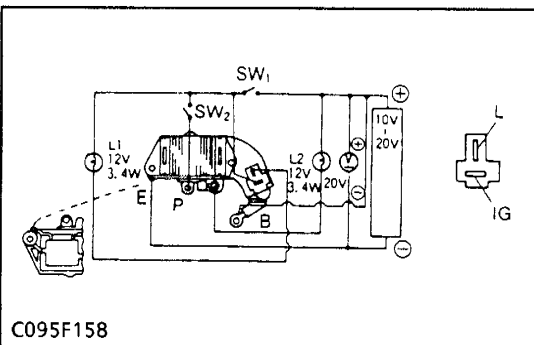

### IC Regulator Test

1. Connect the IC regulator unit, variable DC source, voltmeter, lamps and etc. so that they form a circuit as shown in the figure. (SW1 and SW2 shall be kept in the "OFF" position.)
2. Adjust the source voltage to 12 V.
3. Turn SW1 "ON" check if L1 (charge lamp substitution) is lit brilliantly and L2 (rotor coil substitution) is dimly.
4. Then, turn SW2 "ON" while SW1 is still turned "ON". Check if L1 is turns "OFF" and L2 is lit brilliantly.
5. While keeping SW1 and SW2 in the "ON" position, raise the variable DC source voltage gradually from 12 V and check if the L2 lamp is turned "OFF" at a voltage of 13.9 to 15.1 V at 25 °C (45 °F).

#### ■ IMPORTANT

- A wrong connection in the IC regulator may destroy the regulator in a short time, therefore, inspection of the IC regulator is to be done only after the wiring diagram in the maintenance standard has been thoroughly studied.

## [5] LIGHTING SYSTEM

### CHECKING



### Combination Switch

1. Remove the meter panel, and disconnect the combination switch connectors after turning the main switch off.
2. Perform the following checkings.

- (1) Combination Switch

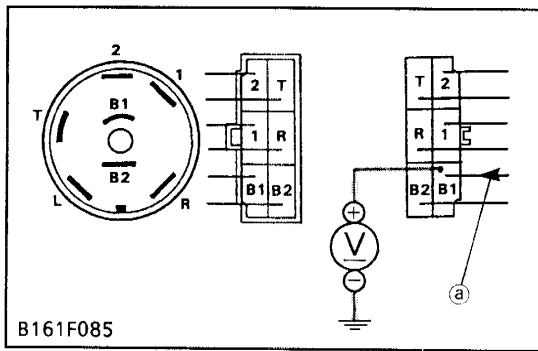

**Connector Voltage**

1. Disconnect the connector from the combination switch (1) after turning the main switch **OFF**.
2. Turn the main switch **ON**, and measure the voltage with a voltmeter across the connector **B1** terminal and the chassis.
3. If the voltage differs from the battery voltage, the wiring harness or main switch is faulty.

Voltage	<b>B1</b> – Chassis	Approx. battery voltage
---------	---------------------	-------------------------

(a) From Main Switch AC Terminal

- (1) Combination Switch (1) Combination Switch

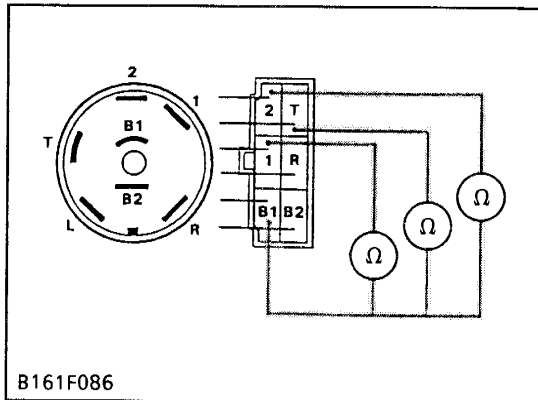

**Head Light Switch Continuity When Setting Switch Knob at OFF Position**

1. Disconnect the connector from the combination switch after turning the main switch **OFF**.
2. Set the light switch knob to the **OFF** position.
3. Measure the resistances with an ohmmeter across the **B1** terminal and 1 terminal, across the **B1** terminal and 2 terminal, and across the **B1** terminal and the T terminal.
4. If infinity is not indicated, the combination switch is faulty.

Resistance Switch knob at <b>OFF</b> position	<b>B1</b> terminal – 1 terminal	Infinity
	<b>B1</b> terminal – 2 terminal	Infinity
	<b>B1</b> terminal – T terminal	Infinity

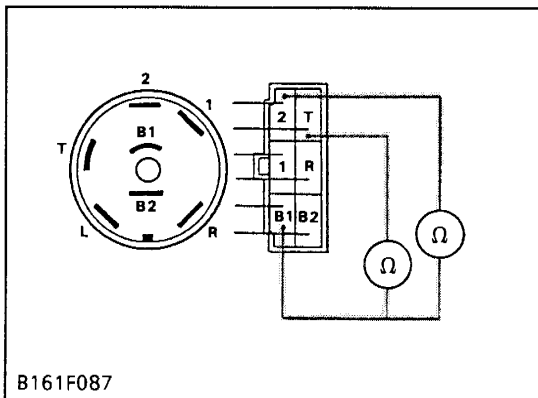

**Head Light Switch Continuity When Setting Switch Knob at LOW-BEAM Position**

1. Measure the resistances with an ohmmeter across the **B1** terminal and 2 terminal, and across the **B1** terminal and T terminal.
2. If 0 ohm is not indicated, the combination switch is faulty.

Resistance Switch knob at <b>LOW-BEAM</b> position	<b>B1</b> terminal – 2 terminal	0 ohm
	<b>B1</b> terminal – T terminal	0 ohm

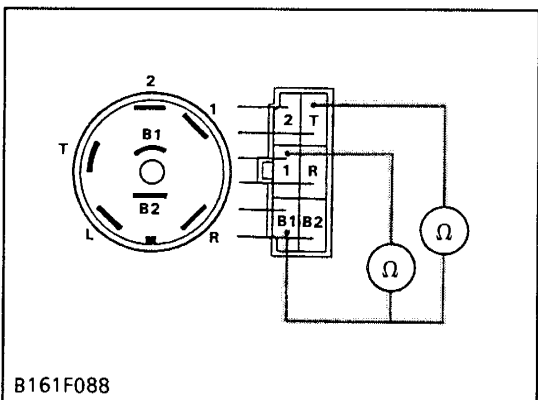

**Head Light Switch Continuity When Setting Switch Knob at HI-BEAM Position**

1. Measure the resistances with an ohmmeter across the **B1** terminal and 1 terminal, and across the **B1** terminal and T terminal.
2. If 0 ohm is not indicated, the combination switch is faulty.

Resistance Switch knob at <b>HI-BEAM</b> position	<b>B1</b> terminal – 1 terminal	0 ohm
	<b>B1</b> terminal – T terminal	0 ohm

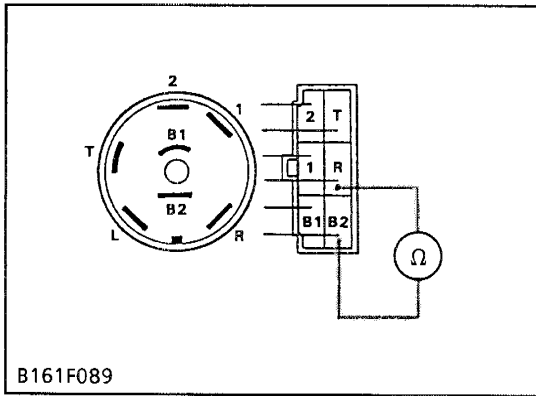

**Hazard Light Switch Continuity When Setting Switch Lever at OFF Position**

1. Disconnect the connector from the combination switch after disconnect the negative cable from the battery.
2. Set the hazard light switch to the OFF position.
3. Measure the resistance with an ohmmeter across the B2 terminal and R terminal.
4. If infinity is not indicated, the combination switch is faulty.

Resistance Switch lever at OFF position	B2 terminal – R terminal	Infinity
---	-----------------------------	----------

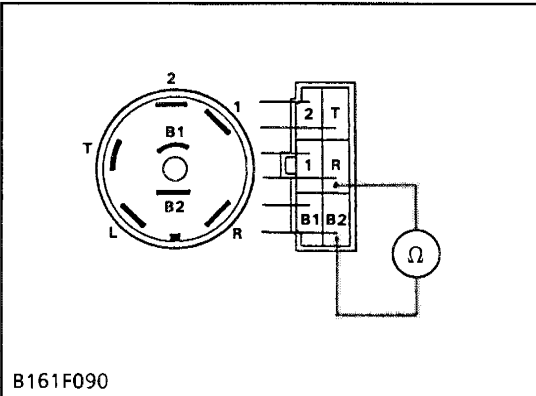

**Hazard Light Switch Continuity When Setting Switch Lever at ON Position**

1. Set the hazard light switch to the ON position.
2. Measure the resistance with an ohmmeter across the B2 terminal and R terminal.
3. If 0 ohm is not indicated, the combination switch is faulty.

Resistance Switch lever at R position	B2 terminal – R terminal	0 ohm
---	-----------------------------	-------

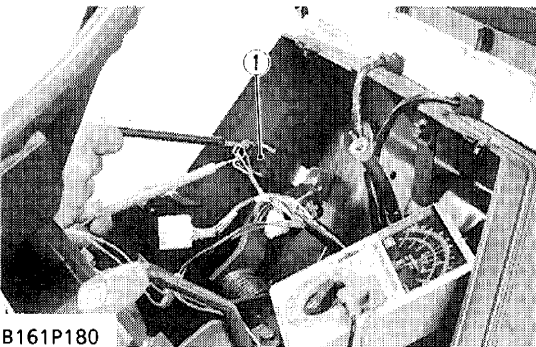

**Hazard Unit Connector Voltage**

1. Disconnect the connector from the hazard unit after disconnect the negative cord from the battery.
2. Connect the negative cord to the battery, and measure the voltage with a voltmeter across the connector B terminal and E terminal.
3. If the voltage differs from the battery voltage, the main switch, fuse or wiring harness is faulty.

Voltage	B terminal – E terminal	Approx. battery voltage
---------	----------------------------	----------------------------

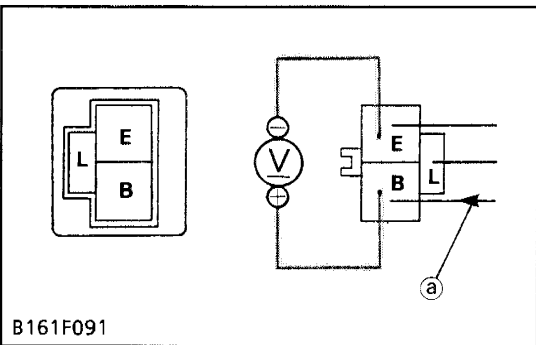

**(a) From Main Switch B Terminal**

- (1) Hazard Unit

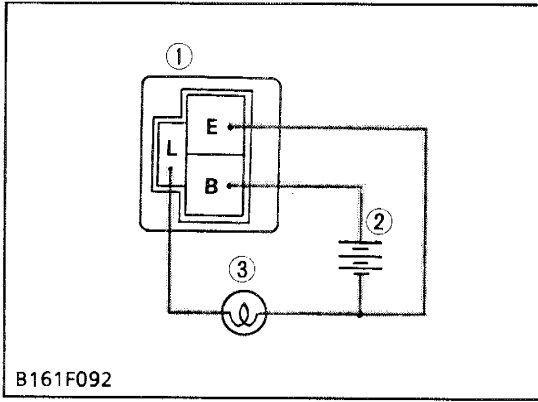

**Hazard Unit Test**

1. Remove the hazard unit from the tractor.
2. Connect jumper leads from the L terminal to the bulb, and from the bulb to the battery negative terminal.
3. Connect jumper lead from the B terminal to the battery positive terminal.
4. Connect jumper lead from the E terminal to the battery negative terminal.
5. If the bulb does not flicker, the hazard unit is faulty.

- (1) Hazard Unit
- (2) Battery (12 V)
- (3) Bulb (27 W)

**[6] WARNING LAMPS**

**CHECKING**

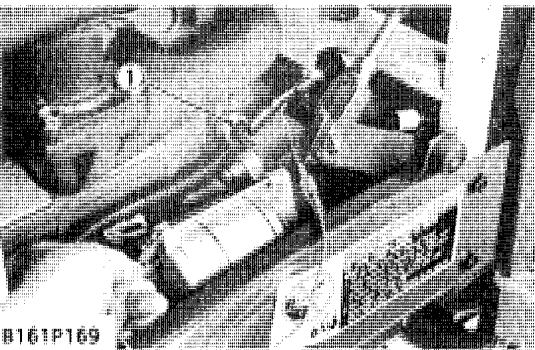

**Engine Oil Pressure Switch Panel Board and Wiring Harness**

1. Disconnect the lead from the engine oil pressure switch after turning the main switch **OFF**.
2. Turn the main switch **ON** and connect a jumper lead from the lead to the chassis.
3. If the engine oil pressure indicator lamp does not light, the panel board circuit or the wiring harness is faulty.

**(a) From Oil Pressure Lamp**

- (1) Engine Oil Pressure Switch

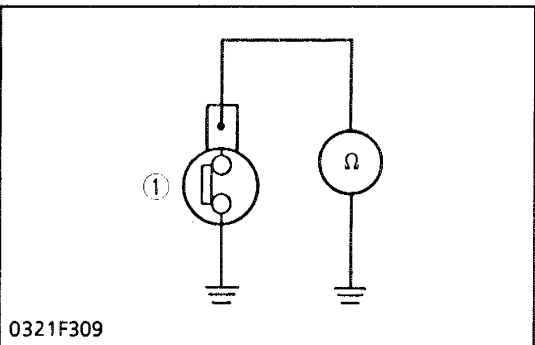
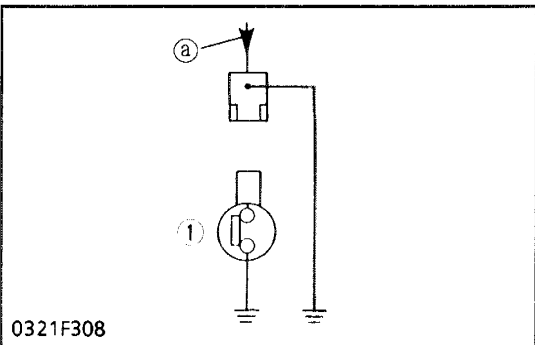

**Engine Oil Pressure Switch Continuity**

1. Measure the resistance with an ohmmeter across the switch terminal and the chassis.
2. If 0 ohm is not indicated in the normal state, the switch is faulty.
3. If infinity is not indicated at pressure over 4.9 kPa (0.5 kgf/cm<sup>2</sup>, 7 psi), the switch is faulty.

Resistance Switch terminal - Chassis	In normal state	0 ohm
	At pressure over approx. 4.9 kPa (0.5 kgf/cm <sup>2</sup> , 7 psi)	Infinity

(1) Engine Oil Pressure Switch



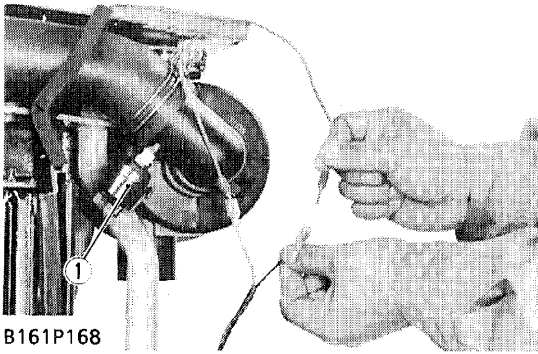

B161P168

**Air Cleaner Sensor Panel Board and Wiring Harness**

1. Disconnect the leads from the air cleaner sensor (1) after turning the main switch **OFF**.
2. Turn the main switch **ON** and connect a jumper lead between the leads.
3. If the air cleaner clogged lamp does not light, the panel board circuit or wiring harness is faulty.

(1) Air Cleaner Sensor

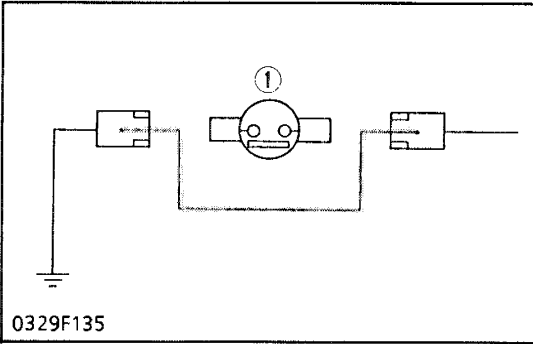

0329F135

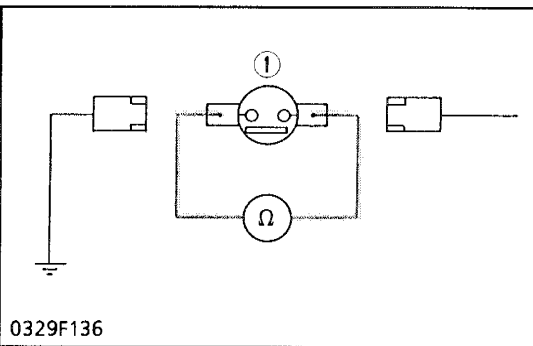

0329F136

**Air Cleaner Sensor Continuity**

1. Disconnect the leads from the air cleaner sensor (1) after turning the main switch **OFF**.
2. Measure the resistance with an ohmmeter across the air cleaner sensor terminals.
3. If infinity is not indicated, the sensor is faulty.

Resistance Across sensor terminals	In normal state	Infinity

(1) Air Cleaner Sensor

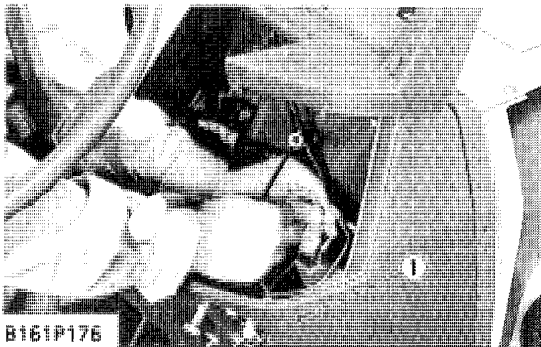

B161P176

**Parking Brake Switch Panel Board and Wiring Harness**

1. Disconnect the leads from the parking brake switch (1) after turning the main switch **OFF**.
2. Turn the main switch **ON** and connect a jumper lead between the leads.
3. If the parking brake indicator lamp does not light, the panel board circuit or wiring harness is faulty.

(1) Parking Brake Switch

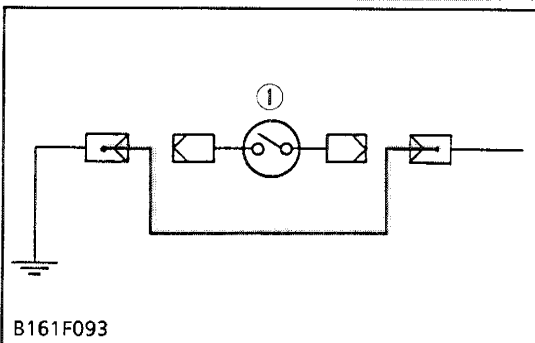

B161F093

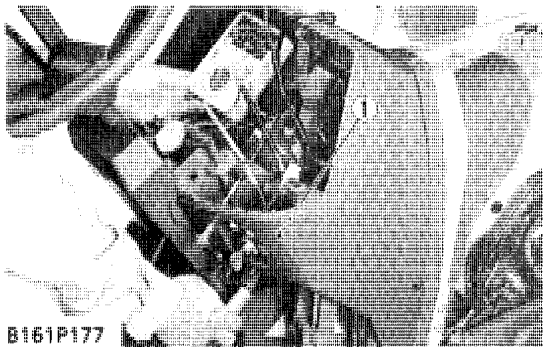

B161P177

**Parking Brake Switch Continuity**

1. Disconnect the leads from the parking brake switch (1) after turning the main switch **OFF**.
2. Measure the resistance with an ohmmeter across the two terminals.
3. If infinity is not indicated, the switch is faulty.

Resistance Across switch terminals	In normal state	Infinity
--	-----------------	----------

(1) Parking Brake Switch

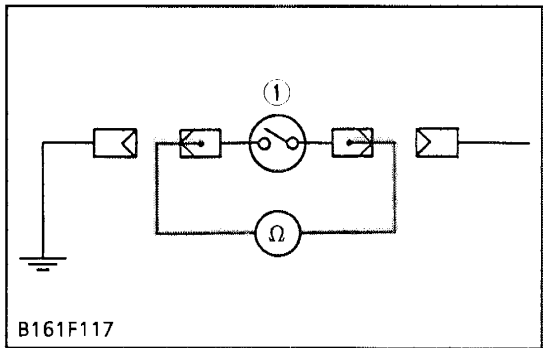

B161F117

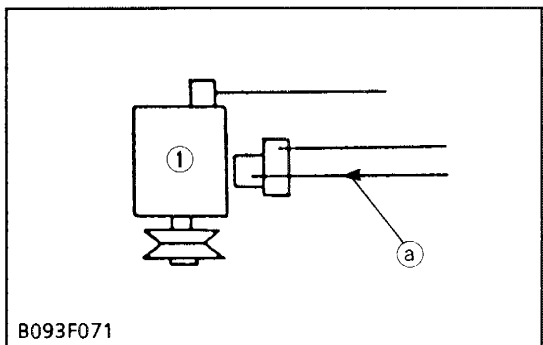

B093F071

**Charging Circuit (Panel Board and Wiring Harness)**

1. Disconnect the **2P** connector from the alternator after turning the main switch **OFF**.
2. Turn the main switch **ON** and connect a jumper lead from the wiring harness connector terminal (**WR**) to the chassis.
3. If the charge lamp does not light, the panel board circuit, alternator, wiring harness, or fuse is fault.

(a) From Charge Lamp

(1) Alternator

## [7] GAUGES CHECKING

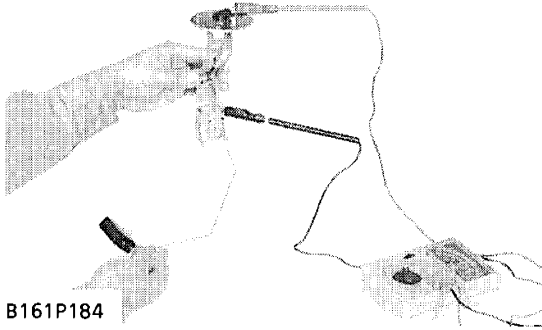

B161P184

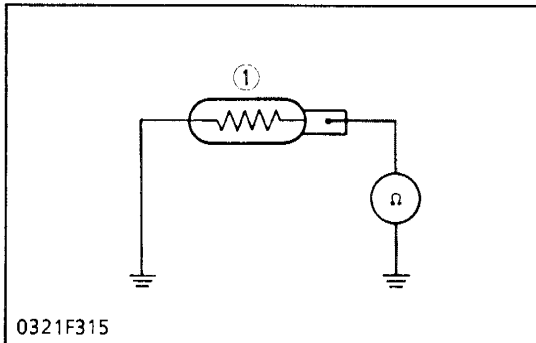

0321F315

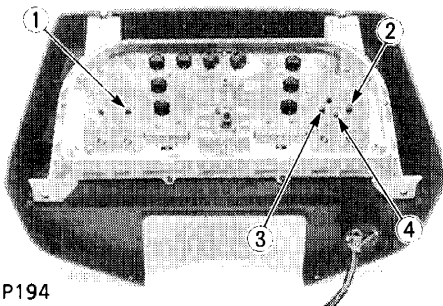

B161P194

### Fuel Level Sensor Continuity

1. Remove the fuel level sensor from the fuel tank.
2. Measure the resistance with an ohmmeter across the sensor terminal and its body.
3. If the measurement are not indicated, the sensor is faulty.

Resistance Sensor terminal – its body	Factory spec.	Float at upper- most position	1 to 5 ohms
		Float at lower- most position	103 to 117 ohms

### Coolant Temperature Sensor Continuity

1. Measure the resistance with an ohmmeter across the sensor terminal and the chassis.
2. If the measurement is not indicated, the sensor is faulty.

Resistance Sensor terminal – Chassis	Reference value	Approx. 16 ohms at 120 °C (248 °F) Approx. 50 ohms at 80 °C (176 °F) Approx. 149 ohms at 50 °C (122 °F)
--	--------------------	---

(1) Coolant Temperature Sensor

### Fuel Gauge and Coolant Temperature Gauge Continuity

1. Remove the panel board from the tractor.
2. Check the continuity with an ohmmeter across the FU terminal (2) and IG terminal (3) and across the FU terminal (2) and GND terminal (4).
3. If infinity is indicated, the fuel gauge is faulty.
4. Check the continuity with an ohmmeter across the TU terminal (1) and IG terminal (3) and across the TU terminal (1) and GND terminal (4).
5. If infinity is indicated, the coolant temperature gauge is faulty.

(1) TU Terminal  
(2) FU Terminal

(3) IG Terminal  
(4) GND Terminal



## SAFETY DECALS

- The following safety decals are installed on the machine.  
If a decal becomes damaged, illegible or is not on the machine, replace it. The decal part number is listed in the parts list.

■ **NOTE**

- Only labels applied to places other than where they are applied on tractors with no cabin are mentioned.

⑨ Part No. 35260-3491-3

### ⚠ CAUTION

**TO AVOID PERSONAL INJURY:**

1. Read and understand the operator's manual before operation.
2. Before starting the engine, make sure that everyone is at a safe distance from the tractor and that the PTO is OFF.
3. Do not allow passengers on the tractor at any time.
4. Before allowing other people to use the tractor, have them read the operator's manual.
5. Check the tightness of all nuts and bolts regularly.
6. Keep all shields in place and stay away from all moving parts.
7. Lock the two brake pedals together before driving on the road.
8. Slow down for turns, or rough roads, or when applying individual brakes.
9. On public roads use SMV emblem and hazard lights, if required by local traffic and safety regulations.
10. Pull only from the drawbar.
11. Before dismounting, lower the implement, set the parking brake, stop the engine and remove the key.

① Part No. TA040-4902-1

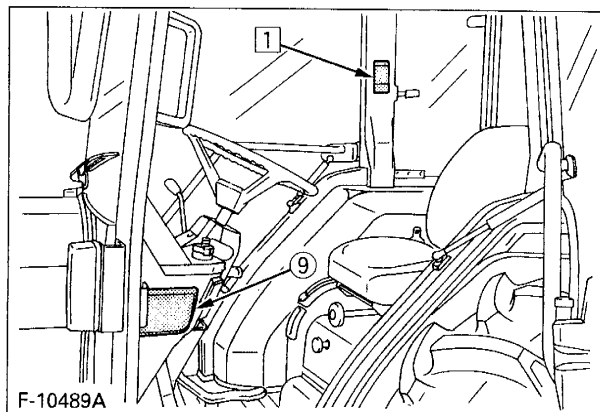

③Part No. TA240-4933-2

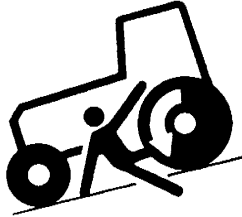
**⚠ WARNING****BEFORE DISMOUNTING TRACTOR:****1. ALWAYS SET PARKING BRAKE.**

Leaving transmission in gear with the engine stopped will not prevent tractor from rolling.

**2. PARK ON LEVEL GROUND WHENEVER POSSIBLE.**

If parking on a slope, position tractor across the slope.

**3. LOWER ALL IMPLEMENTS TO THE GROUND.**

Failure to comply to this warning may allow the wheels to slip, and could cause injury or death.

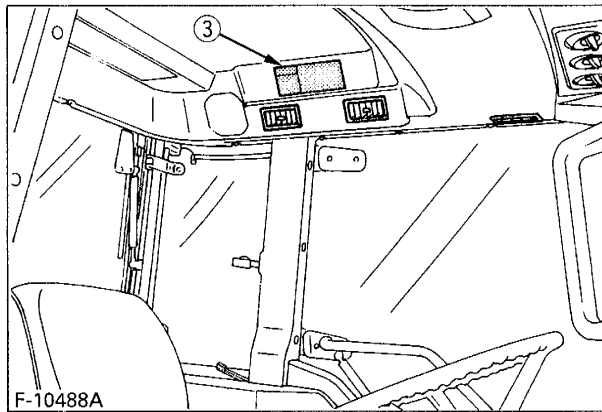
**4. STOP THE ENGINE.**

F-10488A

# SPECIFICATIONS

Model		<b>L3710HST</b>	
		<b>4WD</b>	
Maximum PTO power		22.4 kW (30.0 HP)*	
Engine NET power		27.3 kW (36.6 HP)*	
Engine	Model	V1903-AN	
	Type	Indirect injection, vertical, water-cooled, 4-cycle diesel engine	
	Number of cylinders	4	
	Bore and stroke	80 × 92.4 mm (3.1 × 3.6 in.)	
	Total displacement	1857 cm <sup>3</sup> (113.3 cu.in.)	
	Rated revolution	43.3 r/s (2600 rpm)	
	Combustion chamber	Spherical type (E-TVCS)	
	Fuel injection pump	Bosch type mini pump (PFR4M)	
	Governor	Centrifugal ball mechanical governor	
	Injection nozzle	Throttle type	
	Injection timing	Before T.D.C. 0.314 rad. (18°)	
	Injection order	1-3-4-2	
	Injection pressure	13.73 MPa (140 kgf/cm <sup>2</sup> , 1991 psi)	
	Compression ratio	23 : 1	
	Lubricating system	Forced lubrication by trochoidal pump	
	Cooling system	Pressurized radiator, forced circulation with water pump	
	Starting system	Electric starting with cell starter 12 V, 1.4 kW	
	Alternator	12 V, 720 W (60 AMPS)	
	Battery	447-Cold cranking Amps at – 18 °C (– 0.4 °C)	
	Fuel	Diesel fuel No.1 [below – 10 °C (14 °F)] Diesel fuel No.2 [above –10 °C (14°F)]	
Lubricating oil	CC or CD (API grade)		
Weight (Dry)	206.5 kg (455 lbs)		
Capacities	Fuel tank	35.0 L (9.2 U.S.gal., 7.7 Imp.gal.)	
	Engine crankcase	7.6 L (8.0 U.S.qts., 6.7 Imp.qts.)	
	Engine coolant	8.7 L (9.2 U.S.gal., 7.7 Imp.qts.)	
	Transmission case	39.0 L (10.3 U.S.gal., 8.6 Imp.gal.)	
	Front axle case	5.5 L (5.8 U.S.qts., 4.8 Imp.qts.)	
Dimensions (with Std. tires)	Overall length (without 3P)	3000 mm (118.1 in.)	
	Overall length (with 3P)	3210 mm (126.4 in.)	
	Overall width (Minimum tread)	1425 mm (56.1 in.)	
	Overall height (with CAB)	2155 mm (84.8 in.)	
	Overall height (Top of steering wheel)	1525 mm (60.0 in.)	
	Wheel base	1805 mm (71.1 in.)	
	Minimum ground clearance (Under transmission)	335 mm (13.2 in.)	
	Tread	Front mm (in.)	1155 (45.5)
	Rear mm (in.)	1180 (46.5), 1200 (47.2), 1300 (51.2), 1450 (57.1), 1545 (60.8)	

NOTE : \* Manufacturer's estimate

12190Z00030

Model			L3710HST
			<b>4WD</b>
Travelling system	Tire size (Std. tires)	Front	8.3 – 16
		Rear	13.6 – 24
	Clutch		Dry type single stage
	Steering		Hydrostatic power steering
	Transmission		Hydrostatic transmission (3 speeds)
	Brake	Travelling	Wet disc type
		Parking	Connected with the travelling brake
Differential		Bevel gear	
Hydraulic system	Hydraulic control system		Position control, draft and mixed control (if equipped)
	Pump capacity (Max. flow rate)		Main pump 29.5 L/min. (7.8 GPM), Power steering pump 15.3 L/min. (4.0 GPM)
	Three point hitch		SAE Category I
	Maximum lifting capacity (24 in. behind lower link end)		1050 kg (2310 lbs)
Rear PTO	PTO shaft		SAE 1-3/8, 6-splines (with overrunning clutch)
	Revolution	Independent PTO	1 speed : 9.0 r/s (540 rpm) / engine 40.6 r/s (2436 rpm)
Mid PTO	PTO shaft		USA No.5 (KUBOTA 10-tooth) involute spline
	Revolution	Independent PTO	1 speed : 33.3 r/s (2000 rpm) / engine 39.9 r/s (2394 rpm)
Min. turning radius (with brake)			2.5 m (8.2 ft)
Traction system			Fixed drawbar or swing drawbar (if equipped)
Weight (with CAB)			1585 kg (3490 lbs)

12190Z00040



# SPECIFICATIONS (Continued)

Model		L4310HST		
		2WD	4WD	
Maximum PTO power		26.8 kW (36.0 HP)*		
Engine NET power		32.1 kW (43.0 HP)*		
Engine	Model	V2203-AN		
	Type	Indirect injection, vertical, water-cooled, 4-cycle diesel engine		
	Number of cylinders	4		
	Bore and stroke	87 × 92.4 mm (3.4 × 3.6 in.)		
	Total displacement	2197 cm <sup>3</sup> (114.1 cu.in.)		
	Rated revolution	43.3 r/s (2600 rpm)		
	Combustion chamber	Spherical type (E-TVCS)		
	Fuel injection pump	Bosch type mini pump (PFR4M)		
	Governor	Centrifugal ball mechanical governor		
	Injection nozzle	Throttle type		
	Injection timing	Before T.D.C. 0.314 rad. (18°)		
	Injection order	1-3-4-2		
	Injection pressure	13.73 MPa (140 kgf/cm <sup>2</sup> , 1991 psi)		
	Compression ratio	23 : 1		
	Lubricating system	Forced lubrication by trochoidal pump		
	Cooling system	Pressurized radiator, forced circulation with water pump		
	Starting system	Electric starting with cell starter 12 V, 1.4 kW		
	Alternator	12 V, 720 W (60 AMPS)		
	Battery	447-Cold cranking Amps at – 18 °C (– 0.4 °C)		
	Fuel	Diesel fuel No.1 [below – 10 °C (14 °F)] Diesel fuel No.2 [above – 10 °C (14°F)]		
Lubricating oil	CC or CD (API grade)			
Weight (Dry)	206.5 kg (455 lbs)			
Capacities	Fuel tank	35.0 L (9.2 U.S.gal., 7.7 Imp.gal.)		
	Engine crankcase	7.6 L (8.0 U.S.qts., 6.7 Imp.qts.)		
	Engine coolant	8.7 L (9.2 U.S.gal., 7.7 Imp.qts.)		
	Transmission case	39.0 L (10.3 U.S.gal., 8.6 Imp.gal.)		
	Front axle case	5.5 L (5.8 U.S.qts., 4.8 Imp.qts.)		
Dimensions (with Std. tires)	Overall length (without 3P)	3020 mm (118.9 in.)		
	Overall length (with 3P)	3230 mm (127.2 in.)		
	Overall width (Minimum tread)	1585 mm (62.4 in.)		
	Overall height (with CAB)	2175 mm (85.6 in.)		
	Overall height (Top of steering wheel)	1535 mm (60.4 in.)		
	Wheel base	1810 mm (71.3 in.)	1805 mm (71.1 in.)	
	Minimum ground clearance (Under transmission)	370 mm (14.6 in.)		
	Tread	Front mm (in.)	1145 (45.1), 1245 (49.0) 1345 (53.0), 1445 (56.9)	1155 (45.5)
		Rear mm (in.)	1180 (46.5), 1200 (47.2), 1300 (51.2), 1450 (57.1), 1545 (60.8)	

NOTE : \* Manufacturer's estimate

12190Z00050

Model			L4310HST	
			2WD	4WD
Travelling system	Tire size (Std. tires)	Front	6.00 – 16	8.3 – 16
		Rear	14.9 – 24	
	Clutch		Dry type single stage	
	Steering		Hydrostatic power steering	
	Transmission		Hydrostatic transmission (3 speeds)	
	Brake	Travelling	Wet disc type	
		Parking	Connected with the travelling brake	
Differential		Bevel gear		
Hydraulic system	Hydraulic control system		Position control, draft and mixed control (if equipped)	
	Pump capacity (Max. flow rate)		Main pump 29.5 L/min. (7.8 GPM), Power steering pump 15.3 L/min. (4.0 GPM)	
	Three point hitch		SAE Category I	
	Maximum lifting capacity (24 in. behind lower link end)		1050 kg (2310 lbs)	
Rear PTO	PTO shaft		SAE 1-3/8, 6-splines (with overrunning clutch)	
	Revolution	Independent PTO	1 speed : 9.0 r/s (540 rpm) / engine 40.6 r/s (2436 rpm)	
Min. turning radius (with brake)			2.5 m (8.2 ft)	
Traction system			Fixed drawbar or swing drawbar (if equipped)	
Weight (with CAB)			1495 kg (3300 lbs)	1595 kg (3520 lbs)

12190Z00060

## TRAVELLING SPEEDS

(at rated engine rpm)

Model		L3710HST		L4310HST	
		13.6-24		14.9-24	
Tire size (Rear)					
Range gear shift lever		km/h	mph	km/h	mph
Forward	Low	0 to 5.8	0 to 3.6	0 to 6.0	0 to 3.7
	Middle	0 to 10.8	0 to 6.7	0 to 11.2	0 to 7.0
	High	0 to 23.1	0 to 14.4	0 to 23.9	0 to 14.9
Reverse	Low	0 to 4.6	0 to 2.9	0 to 4.8	0 to 3.0
	Middle	0 to 8.6	0 to 5.4	0 to 9.0	0 to 5.6
	High	0 to 18.5	0 to 11.5	0 to 19.1	0 to 11.9

12190Z00070

# DIMENSIONS

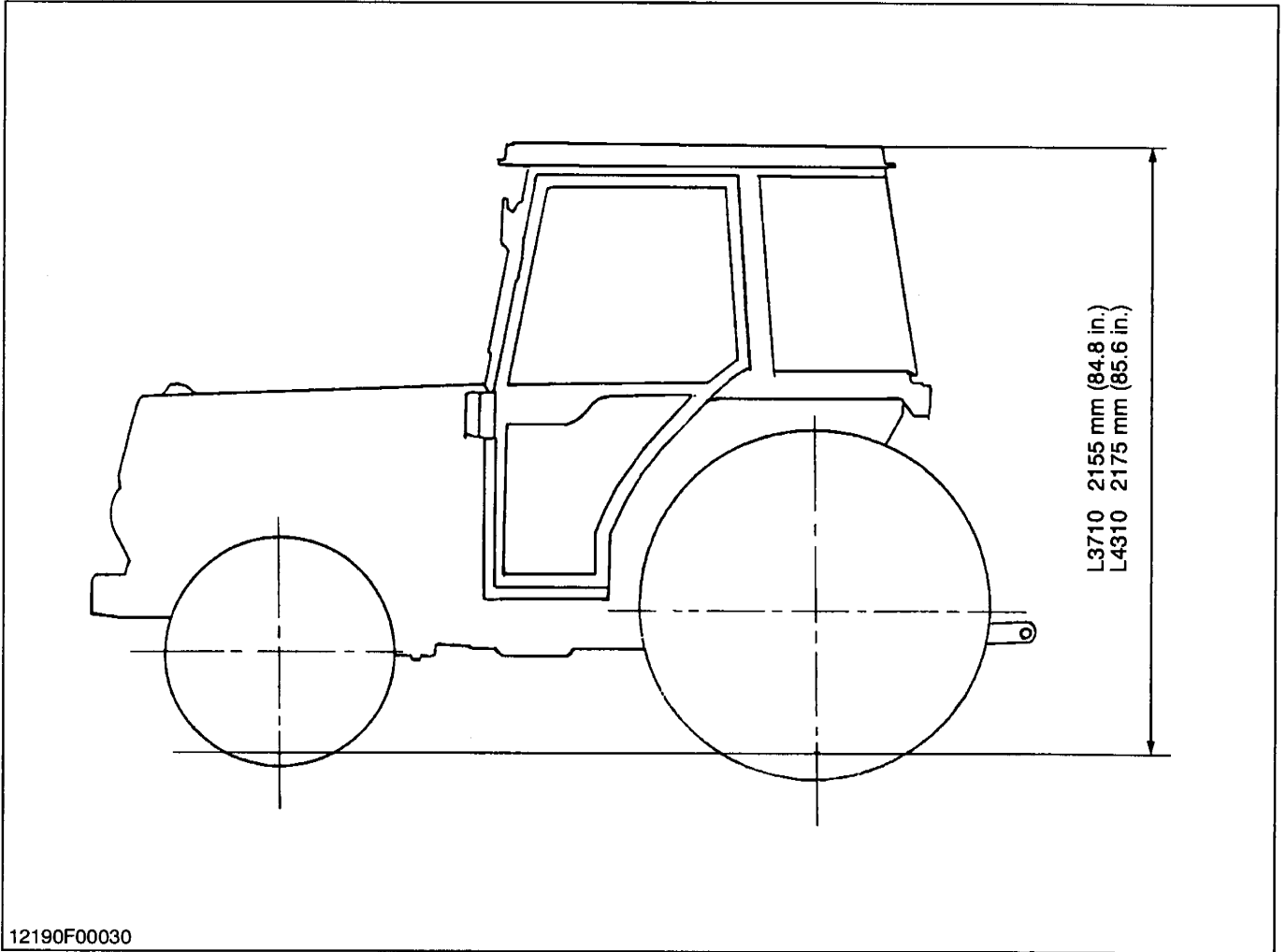

12190Z00080



# GENERAL

## CONTENTS

<b>[1] COOLING WATER</b> .....	10-G1
<b>[2] MAINTENANCE CHECK LIST</b> .....	10-G1
<b>[3] CHECK AND MAINTENANCE</b> .....	10-G1
(1) Daily Check.....	10-G1
(2) Check Points of Every 200 Hours.....	10-G2
(3) Check Points of Every 1 Year.....	10-G3
(4) Others.....	10-G3
<b>[4] SPECIAL TOOLS</b> .....	10-G4



## [1] COOLING WATER

Place	Capacity		Cooling water
	L3710	L4310	
Cooling system	8.7 L 9.2 U.S.qts. 7.7 Imp.qts.		Fresh clean water with anti-freeze

12190G00010

## [2] MAINTENANCE CHECK LIST

No.	Check point	Indication on hour meter (Change or check every interval shown below)								After purchase 1 year	Reference page
		100	200	300	400	500	600	700	800		
1	Air conditioner belt adjustment		☆		☆		☆		☆		10-G2
2	Air conditioner condenser checking		☆		☆		☆		☆		10-G2
3	Fresh air filter cleaning		☆		☆		☆		☆		10-G2
4	Inner air filter cleaning		☆		☆		☆		☆		10-G3
5	Air conditioning system line and clamp checking									☆	10-G3
6	Cabin isomount checking									☆	10-G3
7	Door and rear window hinge lubricating	◆									10-G3
8	Adding washer liquid	◆									10-G3
9	Amount of refrigerant (gas) checking	◆									10-S20

Note :The jobs indicated by ◆ service as required.

12190G00020

## [3] CHECK AND MAINTENANCE

### ⚠ CAUTION

- Be sure to check and service the tractor on a flat place with engine shut off, the parking brake on and chock the wheels.

12190G00030

### (1) Daily Check

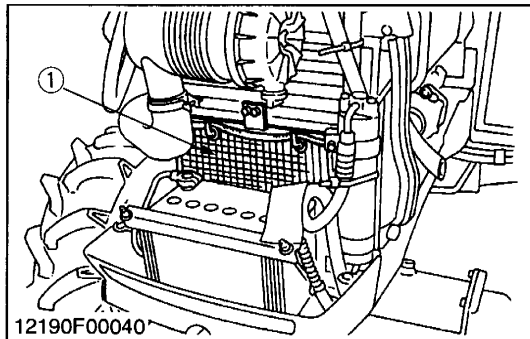

#### Cleaning Insect Control Mesh (For Condenser)

1. Roll up the insect control mesh (1) from below and clean.
2. Finally straighten the mesh down along the condenser.

(1) Insect Control Mesh

12190G00040

**(2) Check Points of Every 200 Hours**

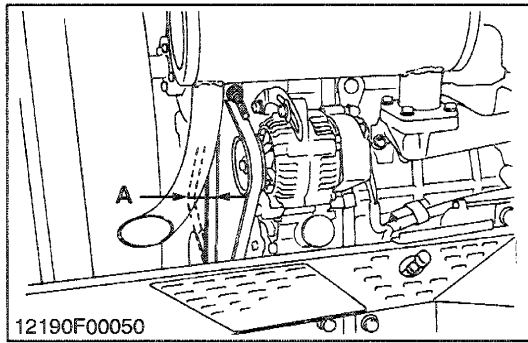

**Adjusting Air Conditioner Belt Tension**

**CAUTION**

- **Be sure to stop the engine before checking air conditioner belt tension.**
- 1. Stop the engine and remove the key.
- 2. Apply 98 N (10 kgf, 22 lbs) pressure to the belt between the pulleys.
- 3. If tension is incorrect, adjust the belt tension.
- 4. If belt is damaged, replace it.

Air conditioner belt tension	Factory spec.	A deflection of between 10 to 12 mm (0.39 to 0.47 in.) when the belt is pressed in the middle of the span
------------------------------	---------------	---

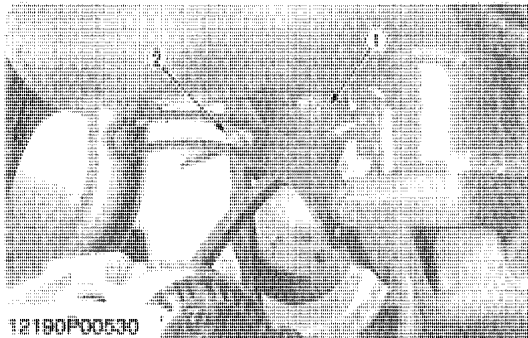

**Adjustment**

1. Disconnect the battery negative cord.
2. Remove the alternator upper mounting screw, then loosen the alternator lower mounting screw and nut.
3. Remove the fan belt from alternator pulley.
4. Loosen the air conditioner belt tension pulley nut (1).
5. Tighten the adjusting nut (2) to adjust the air conditioner belt tension.

- (1) Tension Pulley Nut (A) Deflection  
 (2) Adjusting Nut

12190G00050

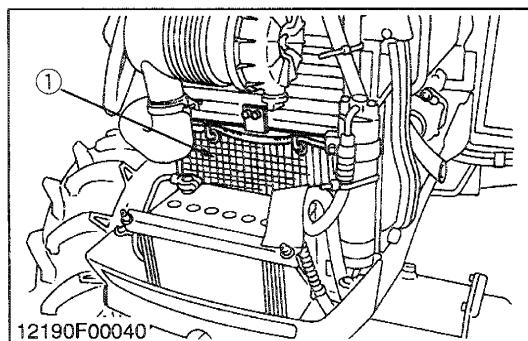

**Checking Air Conditioner Condenser**

1. Check the air conditioner condenser (1).
2. If dust and dirt, wash off all dirt and dust from the condenser (1) with a soft brush, use care not to damage or bend the fins.

- (1) Air Conditioner Condenser

12190G00060

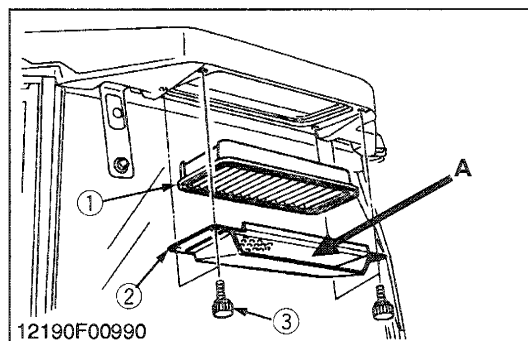

**Cleaning Fresh Air Filter**

1. Remove the knob bolts (3) and pull out filter (1).

**NOTE**

- **Do not hit the filter. If the filter becomes deformed, dust may enter into the air-conditioner, which may cause damage and malfunction.**
- **Do not use gasoline, thinner or similar chemicals to clean the filter as damage to the filter may occur.**
- **It may also cause an unpleasant odor in the CAB when the system is used next.**

- (1) Fresh Air Filter (A) Air Inner Port  
 (2) Cover  
 (3) Knob Bolt

12190G00130



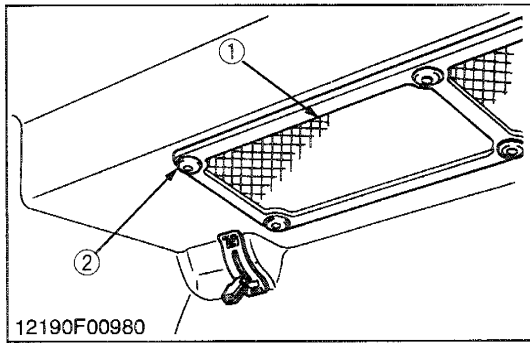

**Cleaning Inner Air Filter**

1. Remove the inner air filter (1), and blow air from the direction opposite to the filter's normal flow.

- (1) Inner Air Filter
- (2) Push-rivet

12190G00120

**(3) Check Points of Every 1 Year**

**Checking Air Conditioner Pipe and Clamp**

1. Check to see that all lines and hose clamps are tight and not damaged.
2. If hoses and clamps are found worn or damaged, replace or repair them at once.

12190G00080

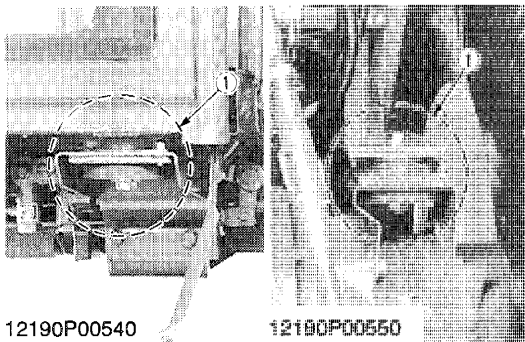

**Checking Cabin Isomount**

1. Check the isomounts (1) for any breakage or fatigue.
2. Replace them if they have deteriorated.

- (1) Isomount

12190G00090

**(4) Others**

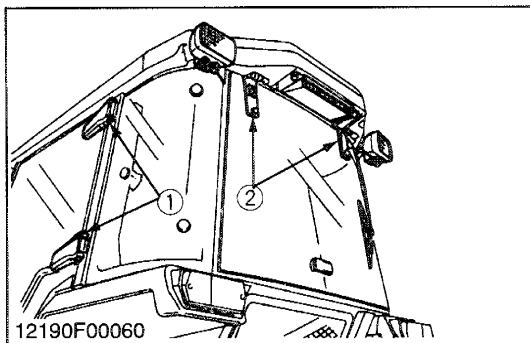

**Lubricating Door and Rear Window Hinge**

1. Apply a small amount of lubricating liquid to the following points when it is necessary.

- (1) Door Hinge
- (2) Rear Window Hinge

12190G00100

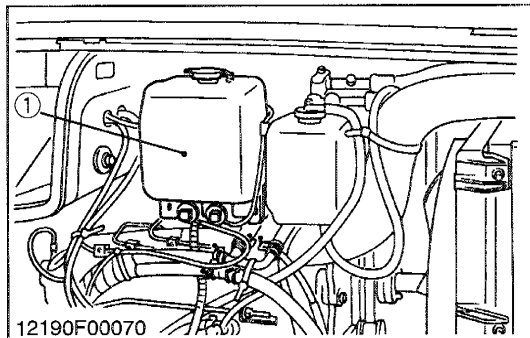

**Adjusting Washer Liquid**

1. Add a proper amount of automobile washer liquid when it is necessary.

Washer liquid tank	Capacity	2.0 L 2.1 U.S.qts. 1.8 Imp.qts.
--------------------	----------	---------------------------------------

- (1) Washer Liquid Tank

12190G00110

## [4] SPECIAL TOOLS

### ■ NOTE

- Special tools for R134a refrigerant air conditioning system introduced below are available from NIPPONDENSO CO. LTD.

12190G00140

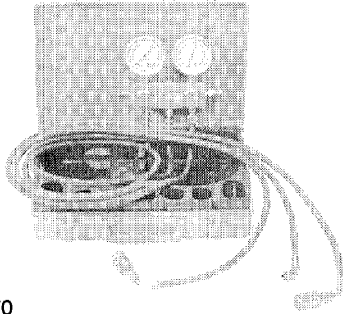

### Air Conditioner Service Tool

Code No: NIPPONDENSO 95048-00061

Application: Use for charging, testing or discharging the air conditioning system.

12190P00570

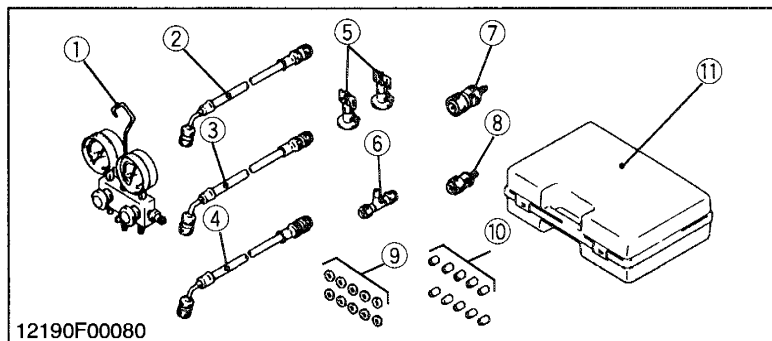

- |                               |             |
|-------------------------------|-------------|
| (1) Manifold Gauge Assembly   | 95048-10090 |
| (2) Charging Hose (Red : HI)  | 95948-10270 |
| (3) Charging Hose (Blue : LO) | 95948-10280 |
| (4) Charging Hose (Green)     | 95948-10260 |
| (5) Can Tap Valve             | 95048-10150 |
| (6) T Joint                   | 95048-10160 |
| (7) Quick Coupler (HI)        | 95048-10130 |
| (8) Quick Coupler (LO)        | 95048-10140 |
| (9) Service Valve Packing     | 95906-10310 |
| (10) Charging Hose Packing    | 95906-10300 |
| (11) Tool Case                | 95949-10610 |

12190F00080

12190G00150

### Electric Gas Leak Tester

Code No: NIPPONDENSO 95146-00060

Application: Use for gas leak testing the air conditioning system.

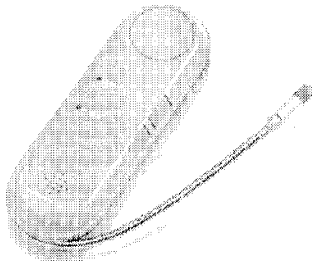

12190P00580

12190G00160

### Vacuum Pump

Code No: NIPPONDENSO 95046-00040 (AC220V)  
95046-00050 (AC240V)

Application: Use for evacuating the air conditioning system.

- |                        |                 |
|------------------------|-----------------|
| (1) Adaptor (For 134a) | (2) Vacuum Pump |
|------------------------|-----------------|

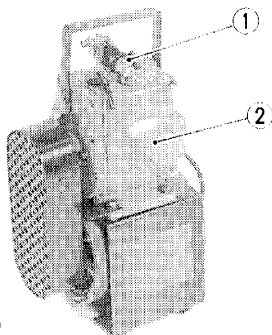

12190P00450

12190G00170

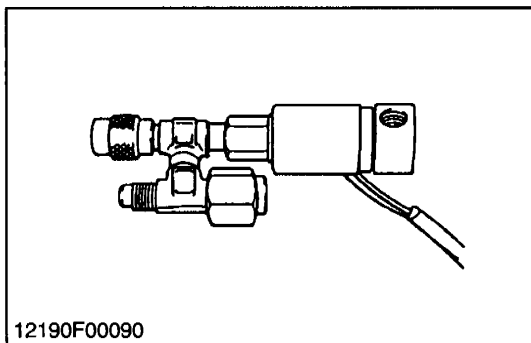

**Adaptor (For R134a)**

Code No: NIPPONDENSO 95048-10190 (AC220V)  
95048-10200 (AC240V)

Application: Use for evacuating the air conditioning system.

12190G00180



# MECHANISM

## CONTENTS

<b>[1] WIRING DIAGRAM</b> .....	10-M1
<b>[2] ELECTRICAL CIRCUIT</b> .....	10-M3
<b>[3] LIGHTING SYSTEM</b> .....	10-M5
(1) Head Light .....	10-M6
(2) Hazard Light .....	10-M7
(3) Turn Signal Light.....	10-M8
(4) Hazard with Turn Signal Light.....	10-M9
<b>[4] AIR CONDITIONER SYSTEM</b> .....	10-M10
(1) Principles of Air Conditioner .....	10-M10
(1)-1 Expansion and Evaporation .....	10-M10
(1)-2 How to Condense Gaseous Refrigerant into Liquid .....	10-M10
(1)-3 Condensing Gaseous.....	10-M11
(1)-4 Refrigeration Cycle.....	10-M11
(2) Outline of Air Conditioning System .....	10-M12
(3) Refrigeration System .....	10-M13
(3)-1 Compressor.....	10-M14
(3)-2 Condenser.....	10-M16
(3)-3 Receiver .....	10-M17
(3)-4 Air Conditioner Unit .....	10-M17
(4) System Control .....	10-M22
(5) Electrical System .....	10-M23
(5)-1 Electrical Circuit .....	10-M23
(5)-2 Air Conditioner Relay, Blower Relays and Compressor Relay.....	10-M24
(5)-3 Air Conditioner Blower Switch.....	10-M24
(5)-4 Pressure Switch .....	10-M25
(5)-5 Thermostat .....	10-M28
<b>[5] WINDSHIELD WIPER</b> .....	10-M28
(1) Front Windshield Wiper .....	10-M28
(2) Window Washer.....	10-M30



**[2] ELECTRICAL CIRCUIT**

**• Color of Wiring**

BR	White
R	Red
L	Blue
Y	Yellow
B	Black
G	Green
P	PK
LG	Light Green
BR	Brown
OR	Orange
SB	Sky Blue
WG	White / Green
WB	White / Black
WR	White / Red
WY	White / Yellow
WL	White / Blue
BW	Black / White
BL	Black / Blue
BY	Black / Yellow
BS	Black / Black
BG	Black / Green
BW	Black / White
BL	Black / Blue
BR	Black / Red
LY	Blue / Yellow
LB	Blue / Black
LG	Light Green
LB	Blue / Red
LO	Light Orange
LG	Light Green
YB	Yellow / Black
YR	Yellow / Red
GR	Green / Red

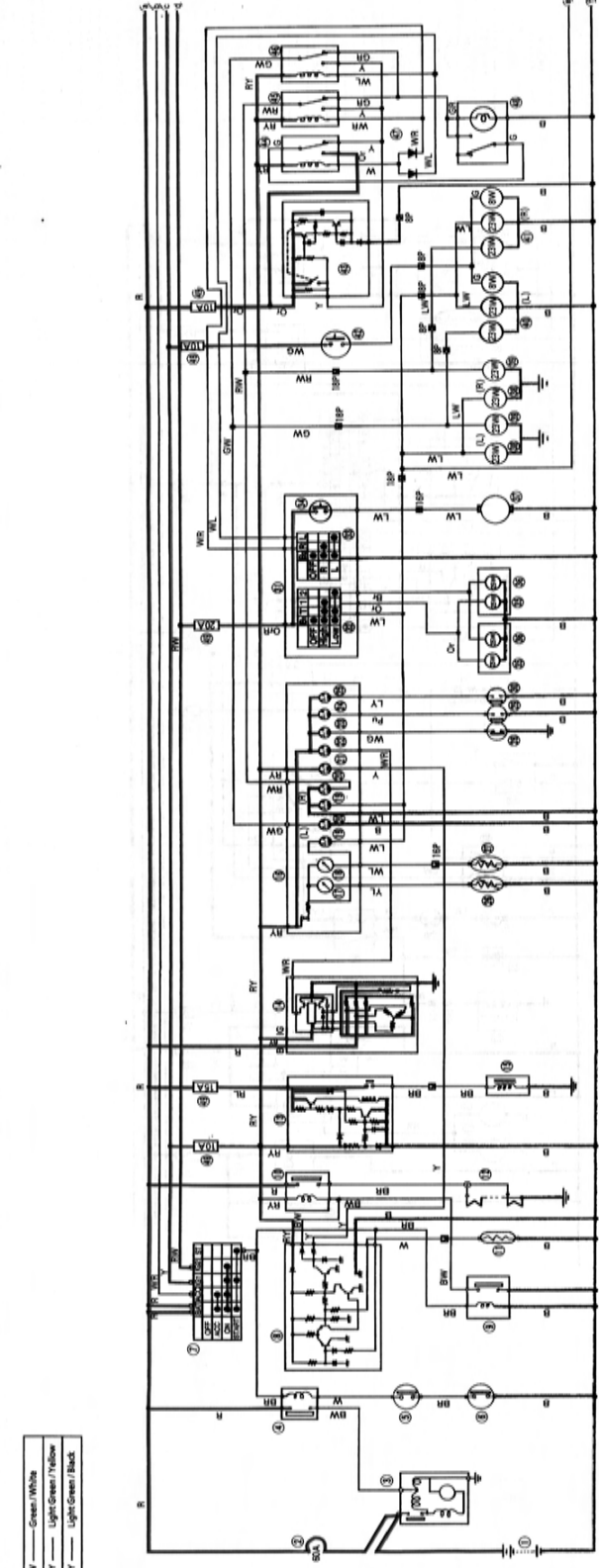

Denotes battery voltage at any position of main switch.  
Denotes battery voltage when turning on main switch "ON" position from "OFF" position.  
Denotes ground line.

- 11) Light Switch
- 12) Main Switch
- 13) Glow Controller
- 14) Stop Timer Relay
- 15) Glow Relay
- 16) Water Temperature Sensor
- 17) Fuel-Cut-Off Solenoid
- 18) Meter Panel
- 19) Fuel Gauge
- 20) Fuel Gauge
- 21) Fuel Gauge
- 22) Coolant Temperature Gauge
- 23) Illumination
- 24) Air Cleaner Clogged Lamp
- 25) Turn Signal Indicators
- 26) Glow Lamp
- 27) Change Lamp
- 28) Engine Oil Pressure Lamp
- 29) Air Cleaner Clogged Lamp
- 30) Turn Signal Switch
- 31) Fuel Level Sensor
- 32) Fuel Level Sensor
- 33) Coolant Temperature Sensor
- 34) Engine Oil Pressure Switch
- 35) Air Cleaner Sensor
- 36) Parking Brake Lamp
- 37) Fuel Level Sensor
- 38) Fuel Level Sensor
- 39) Coolant Temperature Sensor
- 40) Engine Oil Pressure Switch
- 41) Air Cleaner Sensor
- 42) Parking Brake Switch
- 43) Combination Switch
- 44) Light Switch
- 45) Turn Signal Switch
- 46) Horn Switch
- 47) Head Light (Hi-beam)
- 48) Head Light (Low-beam)
- 49) Horn
- 50) Position Light
- 51) Turn Signal Light
- 52) Rear Combination Light
- 53) Turn Signal, Tail
- 54) Rear Combination Light
- 55) Turn Signal, Tail
- 56) Turn Signal Relay R/L
- 57) Turn Signal Relay L/R
- 58) Turn Signal Relay L/R
- 59) Turn Signal Relay L/R
- 60) Turn Signal Relay L/R
- 61) Turn Signal Relay L/R
- 62) Turn Signal Relay L/R
- 63) Turn Signal Relay L/R
- 64) Turn Signal Relay L/R
- 65) Turn Signal Relay L/R
- 66) Turn Signal Relay L/R
- 67) Turn Signal Relay L/R
- 68) Turn Signal Relay L/R
- 69) Turn Signal Relay L/R
- 70) Turn Signal Relay L/R
- 71) Turn Signal Relay L/R
- 72) Turn Signal Relay L/R
- 73) Turn Signal Relay L/R
- 74) Turn Signal Relay L/R
- 75) Turn Signal Relay L/R
- 76) Turn Signal Relay L/R
- 77) Turn Signal Relay L/R
- 78) Turn Signal Relay L/R
- 79) Turn Signal Relay L/R
- 80) Turn Signal Relay L/R
- 81) Turn Signal Relay L/R
- 82) Turn Signal Relay L/R
- 83) Turn Signal Relay L/R
- 84) Turn Signal Relay L/R
- 85) Turn Signal Relay L/R
- 86) Turn Signal Relay L/R
- 87) Turn Signal Relay L/R
- 88) Turn Signal Relay L/R
- 89) Turn Signal Relay L/R
- 90) Turn Signal Relay L/R
- 91) Turn Signal Relay L/R
- 92) Turn Signal Relay L/R
- 93) Turn Signal Relay L/R
- 94) Turn Signal Relay L/R
- 95) Turn Signal Relay L/R
- 96) Turn Signal Relay L/R
- 97) Turn Signal Relay L/R
- 98) Turn Signal Relay L/R
- 99) Turn Signal Relay L/R
- 100) Turn Signal Relay L/R

[2] ELECTRICAL CIRCUIT

• Color of Wiring

W — White	GW — Green / White
R — Red	LgY — Light Green / Yellow
L — Blue	LgB — Light Green / Black
Y — Yellow	
B — Black	
G — Green	
P — Pink	
Lg — Light Green	
Br — Brown	
Or — Orange	
SB — Sky Blue	
WG — White / Green	
WB — White / Black	
WR — White / Red	
WY — White / Yellow	
WL — White / Blue	
RW — Red / White	
RL — Red / Blue	
RY — Red / Yellow	
RB — Red / Black	
RG — Red / Green	
BW — Black / White	
BL — Black / Blue	
BR — Black / Red	
LY — Blue / Yellow	
LW — Blue / White	
LG — Blue / Green	
LR — Blue / Red	
LB — Blue / Black	
LOR — Blue / Orange	
YG — Yellow / Green	
YR — Yellow / Red	
YB — Yellow / Black	
GR — Green / Red	

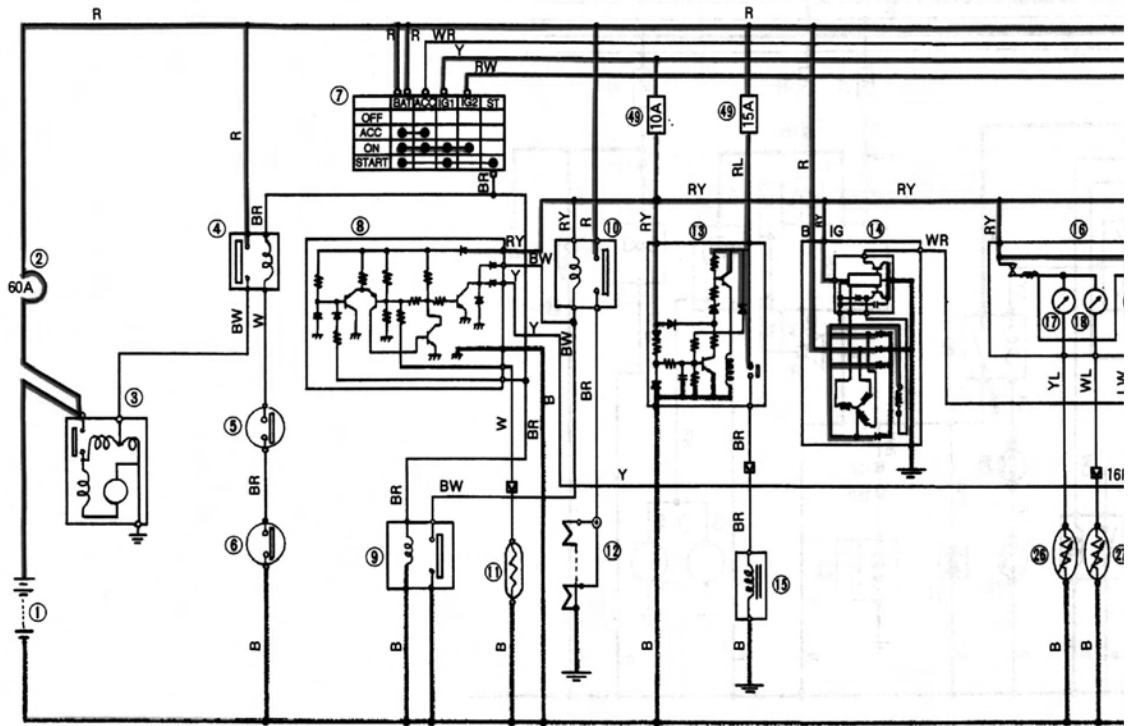

Denotes battery voltage at any position of main switch.  
 Denotes battery voltage when turning on main switch "ON" position from "OFF" position.  
 Denotes ground line.

12190F00120

- |  |                      |   |                                |                               |                                 |      |
|--|----------------------|---|--------------------------------|-------------------------------|---------------------------------|------|
| (1) Battery                            | (6) PTO Limit Switch | (11) Water Temperature Sensor (For Preheating System) | (15) Fuel Cut Off Solenoid     | (20) Turn Signal Indicators   | (25) Parking Brake Lamp         | (30) |
| (2) Slow Blow Fuse                     | (7) Main Switch      | (12) Glow Plugs                                       | (16) Meter Panel               | (21) Glow Lamp                | (26) Fuel Level Sensor          | (31) |
| (3) Starter Motor                      | (8) Glow Controller  | (13) Key Stop Timer Relay                             | (17) Fuel Gauge                | (22) Charge Lamp              | (27) Coolant Temperature Sensor | (32) |
| (4) Starter Relay                      | (9) ST Glow Relay    | (14) Alternator                                       | (18) Coolant Temperature Gauge | (23) Engine Oil Pressure Lamp | (28) Engine Oil Pressure Switch | (33) |
| (5) Shuttle Limit Switch or HST Switch | (10) Glow Relay      |   | (19) Illuminations             | (24) Air Cleaner Clogged Lamp | (29) Air Cleaner Sensor         | (34) |



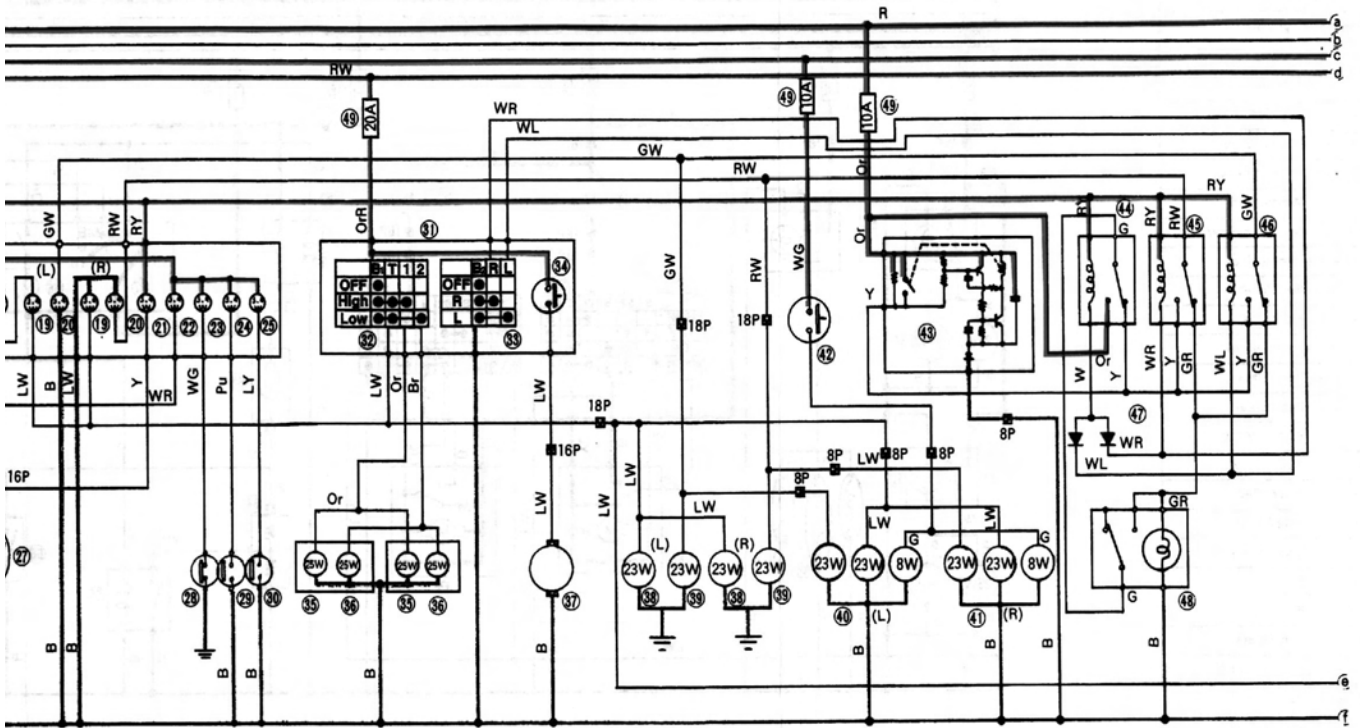

- |                          |                             |                             |                           |                           |
|--------------------------|-----------------------------|-----------------------------|---------------------------|---------------------------|
| 30) Parking Brake Switch | (35) Head Lights (Hi-beam)  | (40) Rear Combination Light | (42) Stop Lamp Switch     | (46) Turn Signal Relay LH |
| 31) Combination Switch   | (36) Head Lights (Low-beam) | (L) (Turn Signal, Tail)     | (43) Hazard Unit          | (47) Diodes               |
| 32) Light Switch         | (37) Horn                   | (41) Rear Combination Light | (44) Hazard Relay         | (48) Hazard Switch        |
| 33) Turn Signal Switch   | (38) Position Light         | (R) (Turn Signal, Tail)     | (45) Turn Signal Relay RH | (49) Fuse                 |
| 34) Horn Switch          | (39) Turn Signal Lights     |                             |                           |                           |



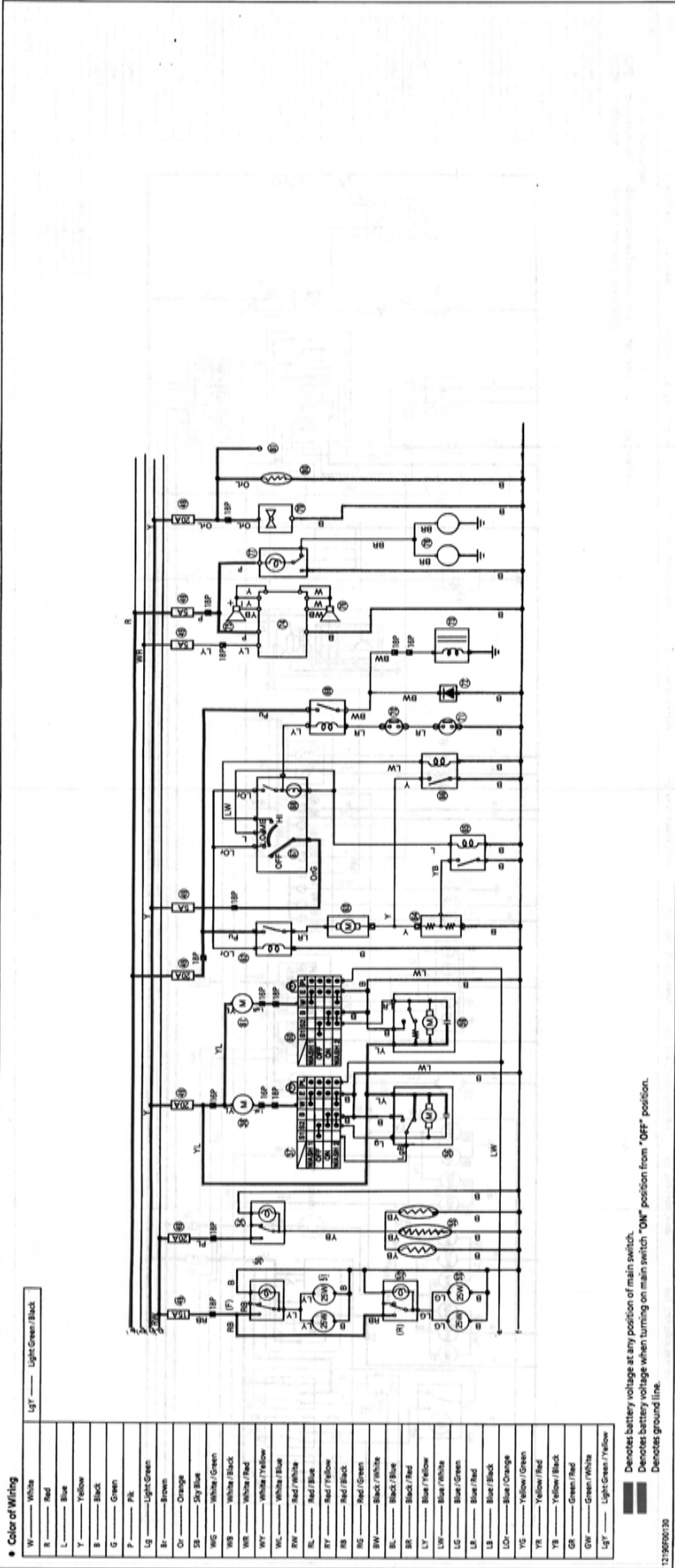

● Color of Wiring

W	White
R	Red
L	Blue
Y	Yellow
B	Black
G	Green
P	Pk
Lg	Light Green
Br	Brown
Or	Orange
Sb	Sky Blue
Wg	White / Green
Wb	White / Black
WY	White / Yellow
Wk	White / Blue
RW	Red / White
Rk	Red / Black
RY	Red / Yellow
RB	Red / Blue
RG	Red / Green
BW	Black / White
Bk	Black / Black
BY	Black / Yellow
LW	Blue / White
LG	Blue / Green
LB	Blue / Black
LO	Blue / Orange
YG	Yellow / Green
YB	Yellow / Black
GB	Green / Black
GW	Green / White
LgY	Light Green / Yellow

Denotes battery voltage at any position of main switch.  
 Denotes battery voltage when turning on main switch "OFF" position from "OFF" position.  
 Denotes ground line.

- (S1) Rear Working Lights
- (S2) Front Working Lights
- (S3) Rear Working Lights
- (S4) Rear Deflagger Switch
- (S5) Rear Deflagger Switch (Option)
- (S6) Rear Deflagger Switch (Option)
- (S7) Front Wiper Switch
- (S8) Front Wiper Switch
- (S9) Wash Motor
- (S10) Wash Motor
- (S11) Wash Motor
- (S12) Wash Motor
- (S13) Wash Motor
- (S14) Wash Motor
- (S15) Wash Motor
- (S16) Wash Motor
- (S17) Wash Motor
- (S18) Wash Motor
- (S19) Wash Motor
- (S20) Wash Motor
- (S21) Wash Motor
- (S22) Wash Motor
- (S23) Wash Motor
- (S24) Wash Motor
- (S25) Wash Motor
- (S26) Wash Motor
- (S27) Wash Motor
- (S28) Wash Motor
- (S29) Wash Motor
- (S30) Wash Motor
- (S31) Wash Motor
- (S32) Wash Motor
- (S33) Wash Motor
- (S34) Wash Motor
- (S35) Wash Motor
- (S36) Wash Motor
- (S37) Wash Motor
- (S38) Wash Motor
- (S39) Wash Motor
- (S40) Wash Motor
- (S41) Wash Motor
- (S42) Wash Motor
- (S43) Wash Motor
- (S44) Wash Motor
- (S45) Wash Motor
- (S46) Wash Motor
- (S47) Wash Motor
- (S48) Wash Motor
- (S49) Wash Motor
- (S50) Wash Motor
- (S51) Wash Motor
- (S52) Wash Motor
- (S53) Wash Motor
- (S54) Wash Motor
- (S55) Wash Motor
- (S56) Wash Motor
- (S57) Wash Motor
- (S58) Wash Motor
- (S59) Wash Motor
- (S60) Wash Motor
- (S61) Wash Motor
- (S62) Wash Motor
- (S63) Wash Motor
- (S64) Wash Motor
- (S65) Wash Motor
- (S66) Wash Motor
- (S67) Wash Motor
- (S68) Wash Motor
- (S69) Wash Motor
- (S70) Wash Motor
- (S71) Wash Motor
- (S72) Wash Motor
- (S73) Wash Motor
- (S74) Wash Motor
- (S75) Wash Motor
- (S76) Wash Motor
- (S77) Wash Motor
- (S78) Wash Motor
- (S79) Wash Motor
- (S80) Wash Motor
- (S81) Wash Motor
- (S82) Wash Motor
- (S83) Wash Motor
- (S84) Wash Motor
- (S85) Wash Motor
- (S86) Wash Motor
- (S87) Wash Motor
- (S88) Wash Motor
- (S89) Wash Motor
- (S90) Wash Motor
- (S91) Wash Motor
- (S92) Wash Motor
- (S93) Wash Motor
- (S94) Wash Motor
- (S95) Wash Motor
- (S96) Wash Motor
- (S97) Wash Motor
- (S98) Wash Motor
- (S99) Wash Motor
- (S100) Wash Motor

● Color of Wiring

W ----- White	LgY ----- Light Green / Black
R ----- Red	
L ----- Blue	
Y ----- Yellow	
B ----- Black	
G ----- Green	
P ----- Pk	
Lg ----- Light Green	
Br ----- Brown	
Or ----- Orange	
SB ----- Sky Blue	
WG ----- White / Green	
WB ----- White / Black	
WR ----- White / Red	
WY ----- White / Yellow	
WL ----- White / Blue	
RW ----- Red / White	
RL ----- Red / Blue	
RY ----- Red / Yellow	
RB ----- Red / Black	
RG ----- Red / Green	
BW ----- Black / White	
BL ----- Black / Blue	
BR ----- Black / Red	
LY ----- Blue / Yellow	
LW ----- Blue / White	
LG ----- Blue / Green	
LR ----- Blue / Red	
LB ----- Blue / Black	
LOR ----- Blue / Orange	
YG ----- Yellow / Green	
YR ----- Yellow / Red	
YB ----- Yellow / Black	
GR ----- Green / Red	
GW ----- Green / White	
LgY ----- Light Green / Yellow	

Denotes battery voltage at any position of main switch.  
 Denotes battery voltage when turning on main switch "ON" position from "OFF" position.  
 Denotes ground line.

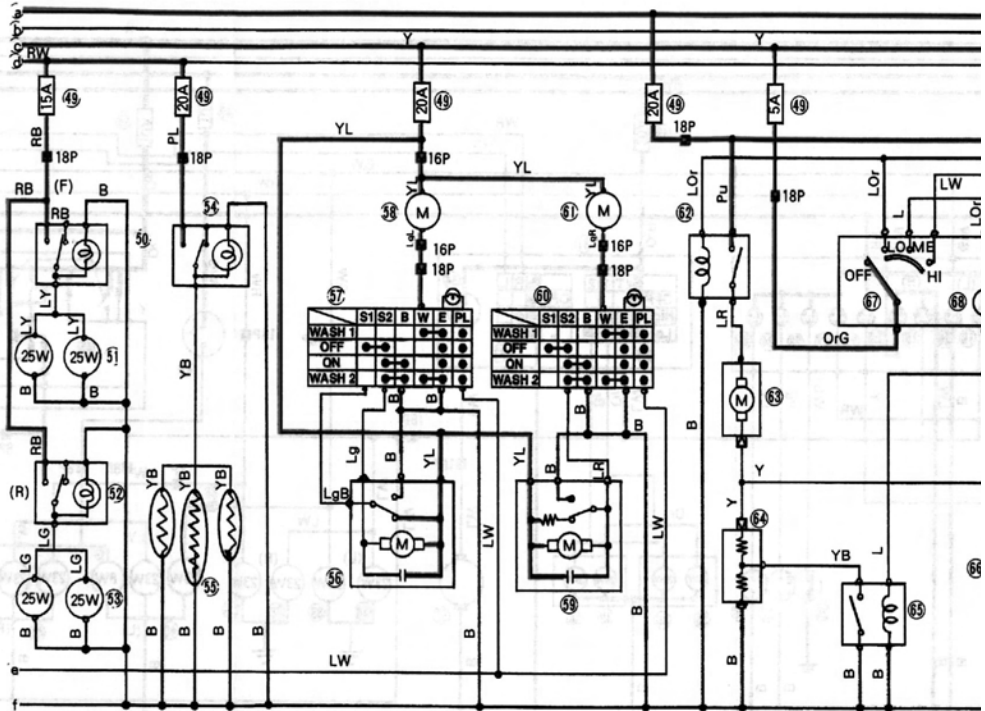

12190F00130

- |   |                                    |                              |                                |                          |                          |      |
|---|------------------------------------|------------------------------|--------------------------------|--------------------------|--------------------------|------|
| (49) Fuse                               | (53) Rear Working Lights (Option)  | (55) Rear Defoggers (Option) | (59) Rear Wiper Motor (Option) | (63) A/C Blower Motor    | (66) Blower Relay 2 (HI) | (69) |
| (50) Front Working Lights Switch        | (54) Rear Defogger Switch (Option) | (56) Front Wiper Motor       | (60) Rear Wiper Switch         | (64) A/C Blower Resistor | (67) A/C Blower Switch   | (70) |
| (51) Front Working Lights               |                                    | (57) Front Wiper Switch      | (61) Washer Motor              | (65) Blower Relay 1 (ME) | (68) A/C Switch          | (71) |
| (52) Rear Working Light Switch (Option) |                                    | (58) Washer Motor            | (62) A/C Blower Motor          |                          |                          |      |

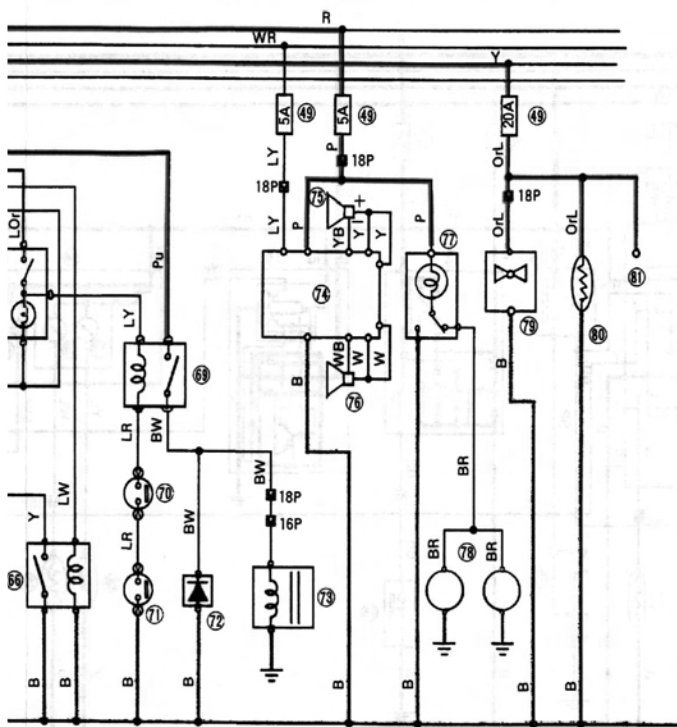

- |                          |                                     |                          |                    |                         |
|--------------------------|-------------------------------------|--------------------------|--------------------|-------------------------|
| (9) A/C Compressor Relay | (72) Diode                          | (75) Speaker RH (Option) | (78) Door Switch   | (80) Ciger Lighter      |
| (0) Pressuer Switch      | (73) Compressor                     | (76) Speaker LH (Option) | (79) Patrol Light  | (81) Spare Power Source |
| (1) Thermo Switch        | (74) Radio Cassette Player (Option) | (77) Dome Light          | (80) Ciger Lighter |                         |



### [3] LIGHTING SYSTEM

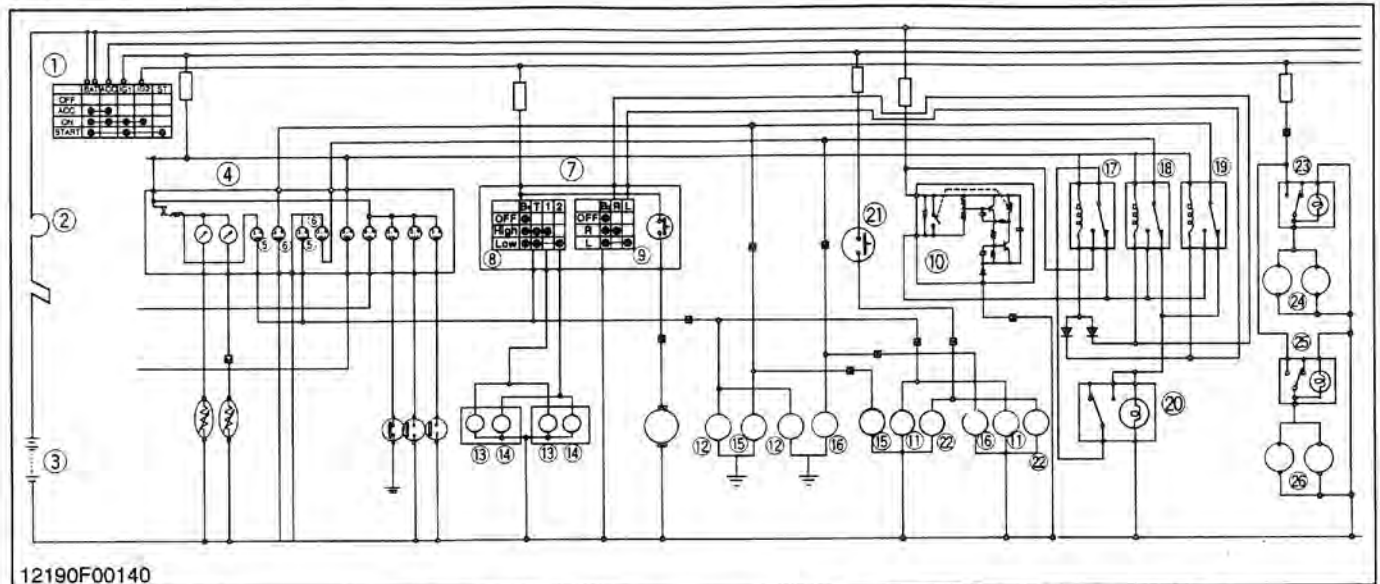

12190F00140

- |  |                              |                                       |                                   |
|--|------------------------------|---------------------------------------|-----------------------------------|
| (1) Main Switch                          | (8) Light Switch             | (15) Hazard (Turn Signal) Lights (LH) | (20) Hazard Switch                |
| (2) Slow Blow Fuse                       | (9) Turn Signal Switch       | (16) Hazard (Turn Signal) Lights (RH) | (21) Stop Lamp Switch             |
| (3) Battery                              | (10) Hazard Unit             | (17) Hazard Relay                     | (22) Stop Lamps                   |
| (4) Panel Board                          | (11) Tail Lights             | (18) Turn Signal Relay (RH)           | (23) Working Light Switch (Front) |
| (5) Panel Board Illuminations            | (12) Position Lights         | (19) Turn Signal Relay (LH)           | (24) Working Lights (Front)       |
| (6) Hazard (Turn Signal) Indicator Lamps | (13) Head Lights (HIGH-beam) |                                       | (25) Working Light Switch (Rear)  |
| (7) Combination Switch                   | (14) Head Lights (LOW-beam)  |                                       | (26) Working Lights (Rear)        |

The lighting system consists of combination switch (light switch and turn signal switch), head lights, tail lights, position lights, panel board illuminations, hazard

(turn signal) lights, hazard unit, hazard switch, relays, stop lamp switch, stop lamps, working light switch, working lights, etc.

12190M00010





## (2) Hazard Light

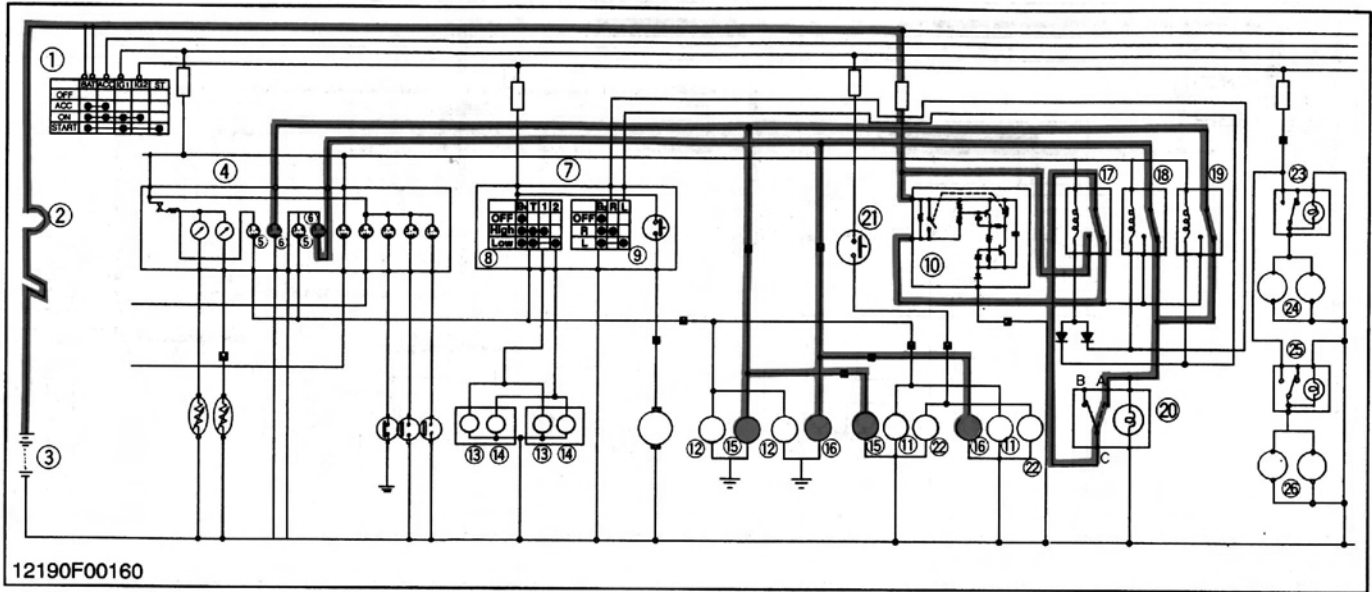

12190F00160

- |  |                              |                                       |                                   |
|--|------------------------------|---------------------------------------|-----------------------------------|
| (1) Main Switch                          | (8) Light Switch             | (15) Hazard (Turn Signal) Lights (LH) | (20) Hazard Switch                |
| (2) Slow Blow Fuse                       | (9) Turn Signal Switch       | (16) Hazard (Turn Signal) Lights (RH) | (21) Stop Lamp Switch             |
| (3) Battery                              | (10) Hazard Unit             | (17) Hazard Relay                     | (22) Stop Lamps                   |
| (4) Panel Board                          | (11) Tail Lights             | (18) Turn Signal Relay (RH)           | (23) Working Light Switch (Front) |
| (5) Panel Board Illuminations            | (12) Position Lights         | (19) Turn Signal Relay (LH)           | (24) Working Lights (Front)       |
| (6) Hazard (Turn Signal) Indicator Lamps | (13) Head Lights (HIGH-beam) |                                       | (25) Working Light Switch (Rear)  |
| (7) Combination Switch                   | (14) Head Lights (LOW-beam)  |                                       | (26) Working Lights (Rear)        |

When the hazard switch (20) is turned **ON**, current from the battery (3) becomes intermittent current at the hazard unit (10), and flows to the hazard relay (17) and **A** terminal of the hazard switch (20).

Intermittent current from **C** terminal of the hazard switch (20) flows simultaneously to turn signal relays (18), (19) and hazard (turn signal) lights (15), (16) and hazard (turn signal) indicator lamps (6) blink on and off. The indicator lamp of the hazard switch (20) also blinks on and off at the same time.

12190M00030

### (3) Turn Signal Light

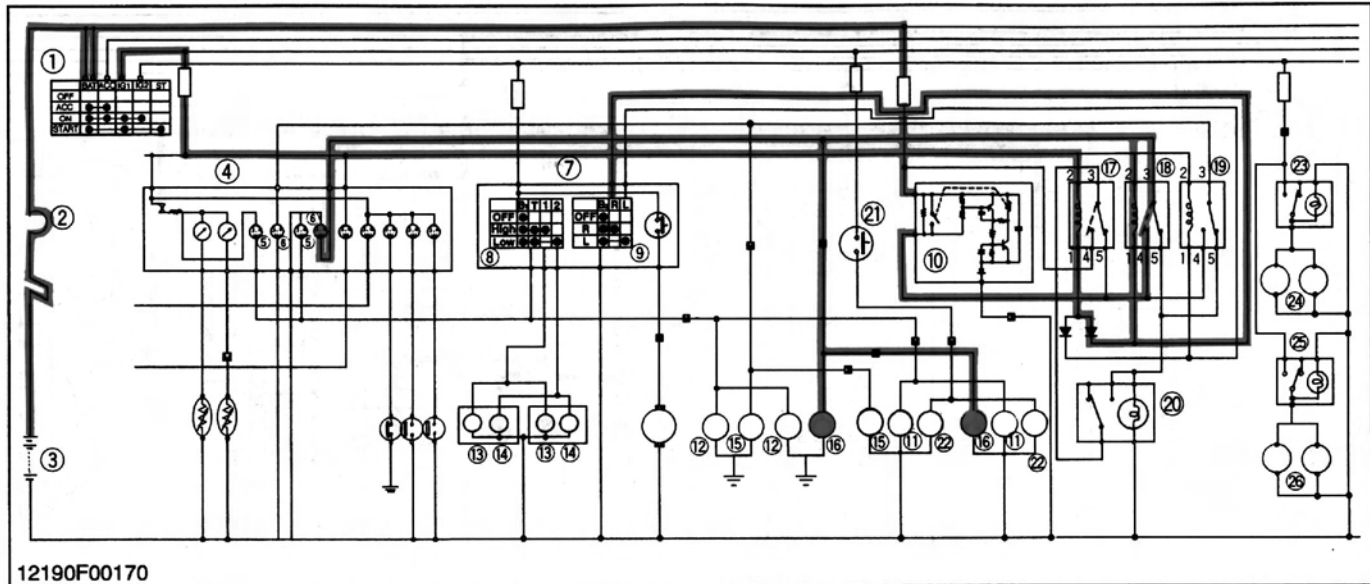

12190F00170

- |  |                                       |                                       |                                   |
|--|---------------------------------------|---------------------------------------|-----------------------------------|
| (1) Main Switch                          | (7) Combination Switch                | (14) Head Lights ( <b>LOW</b> -beam)  | (21) Stop Lamp Switch             |
| (2) Slow Blow Fuse                       | (8) Light Switch                      | (15) Hazard (Turn Signal) Lights (LH) | (22) Stop Lamps                   |
| (3) Battery                              | (9) Turn Signal Switch                | (16) Hazard (Turn Signal) Lights (RH) | (23) Working Light Switch (Front) |
| (4) Panel Board                          | (10) Hazard Unit                      | (17) Hazard Relay                     | (24) Working Lights (Front)       |
| (5) Panel Board Illuminations            | (11) Tail Lights                      | (18) Turn Signal Relay (RH)           | (25) Working Light Switch (Rear)  |
| (6) Hazard (Turn Signal) Indicator Lamps | (12) Position Lights                  | (19) Turn Signal Relay (LH)           | (26) Working Lights (Rear)        |
|  | (13) Head Lights ( <b>HIGH</b> -beam) | (20) Hazard Switch                    |                                   |

#### ■ Right Turning

When the main switch (1) is turned **ON** and the turn signal switch (9) is set to "**R**", current from **AC** terminal flows to the coil of the hazard relay (17) and the coil of the turn signal relay (RH) (18), and both relays are switched to 4 terminal.

Current from the battery (3) flows to the hazard unit (10), becomes intermittent current, flows to 4 terminal of the turn signal relay (RH) (18), and the hazard (turn signal) lights (RH) (16) and hazard (turn signal) indicator lamp (RH) blink on and off.

#### ■ Left Turning

Same as with right turning.

12190M00040

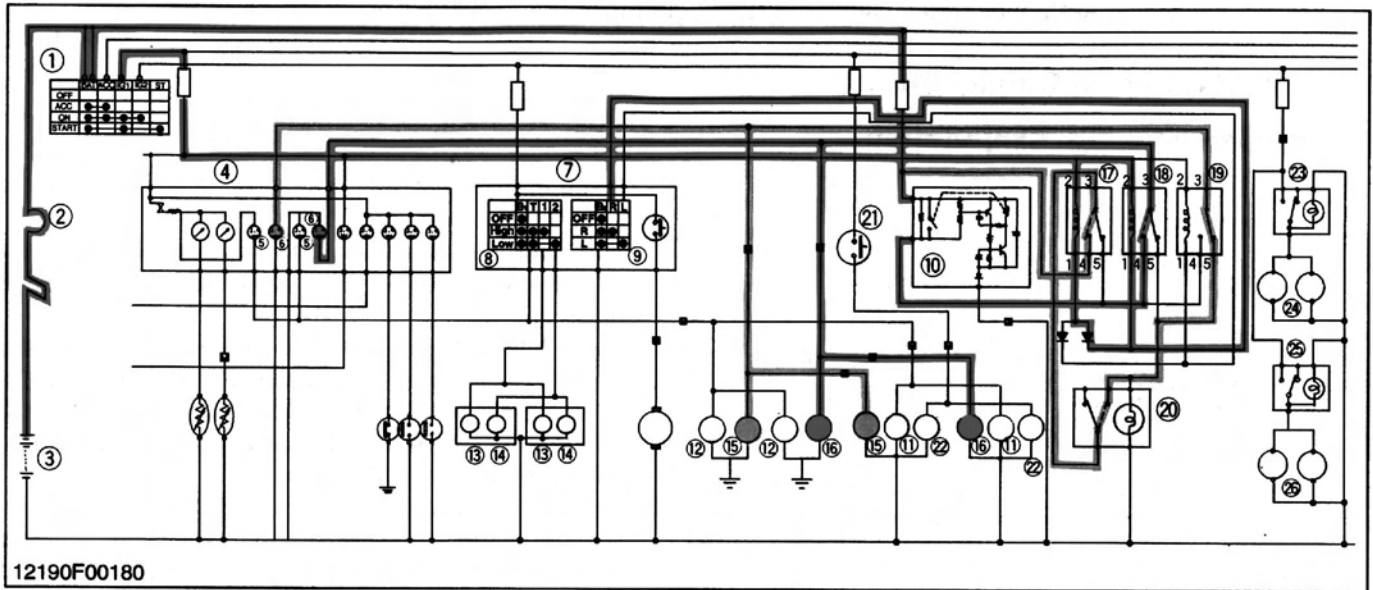
**(4) Hazard with Turn Signal Light**

12190F00180

- |  |                              |                                       |                                   |
|--|------------------------------|---------------------------------------|-----------------------------------|
| (1) Main Switch                          | (7) Combination Switch       | (14) Head Lights (LOW-beam)           | (21) Stop Lamp Switch             |
| (2) Slow Blow Fuse                       | (8) Light Switch             | (15) Hazard (Turn Signal) Lights (LH) | (22) Stop Lamps                   |
| (3) Battery                              | (9) Turn Signal Switch       | (16) Hazard (Turn Signal) Lights (RH) | (23) Working Light Switch (Front) |
| (4) Panel Board                          | (10) Hazard Unit             | (17) Hazard Relay                     | (24) Working Lights (Front)       |
| (5) Panel Board Illumination             | (11) Tail Lights             | (18) Turn Signal Relay (RH)           | (25) Working Light Switch (Rear)  |
| (6) Hazard (Turn Signal) Indicator Lamps | (12) Position Lights         | (19) Turn Signal Relay (LH)           | (26) Working Lights (Rear)        |
|  | (13) Head Lights (HIGH-beam) | (20) Hazard Switch                    |                                   |

When you turn the main switch (1) **ON**, and set the turn signal switch (9) to "**R**" while the hazard light is actuated, the current from **AC** terminal of the main switch (1) flows to the coil of the hazard relay (17) and the coil of the turn signal relay (RH) (18), and both relays are switched to **4** terminal.

Current from the battery (3) flows simultaneously to the hazard unit (10) and **4** terminal of the hazard relay (17).

The current that flowed to the hazard unit (10) turns into intermittent current, flows to **4** terminal of the turn signal relay (RH) (18), causing the hazard (turn signal) lights (RH) (16) and the hazard (turn signal) indicator lamp (RH) to blink on and off.

Current from **4** terminal of the hazard relay (17) flows to **A** terminal of the hazard switch (20).

Current from **C** terminal of the hazard switch (20) flows to **4** terminal of the turn signal relay (LH) (19), turning the hazard (turn signal) lights (LH) (15) and hazard (turn signal) indicator lamp (LH) on. At the same time, the indicator lamp of the hazard switch (20) is also turned on. The same goes for when the turn signal switch (9) is set to "**L**".

12190M00050

## [4] AIR CONDITIONER SYSTEM

The air conditioner system operates using R134a refrigerant.

12190M00060

### (1) Principles of Air Conditioner

#### (1)-1 Expansion and Evaporation

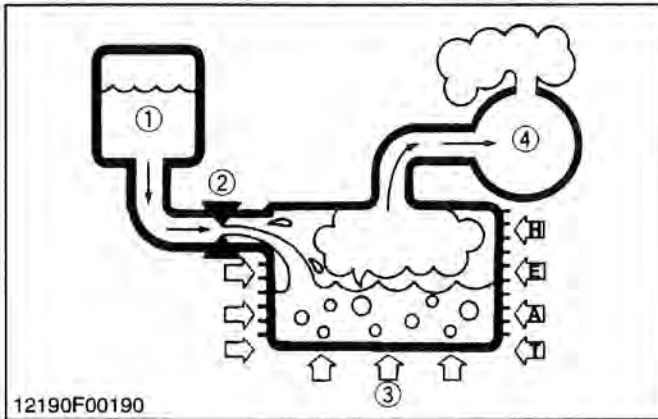

In the mechanical refrigeration system, the cool air is made by the following methods.

1. The high temperature and high pressure liquid refrigerant is stored in the container which is called receiver (1).
2. Then, the liquid refrigerant is released to evaporator (3) through a small hole, called expansion valve (2). At this time, temperature and pressure of the liquid refrigerant are lowered too, and some of the liquid refrigerant is changed to vapor.
3. The low temperature and low pressure refrigerant flows into the container, called evaporator. In the evaporator, the liquid refrigerant evaporates and removes heat from the surrounding air.

- |                     |                |
|---------------------|----------------|
| (1) Receiver        | (3) Evaporator |
| (2) Expansion Valve | (4) Pump       |

12190M00070

#### (1)-2 How to Condense Gaseous Refrigerant into Liquid

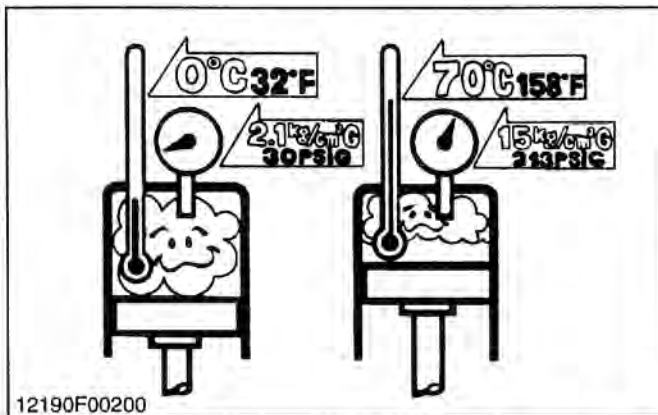

The mechanical refrigerant system changes the refrigerant from the gaseous state to the liquid state while it is passing through the evaporator.

When gas is compressed, both temperature and pressure increase. For example, when gaseous refrigerant is compressed from 0.21 MPa (2.1 kgf/cm<sup>2</sup>, 30 psi) to 1.47 MPa (15 kgf/cm<sup>2</sup>, 213 psi), temperature of the gaseous refrigerant rises from 0 °C (32 °F) to 70 °C (158 °F). The boiling point of refrigerant at 1.47 MPa (15 kgf/cm<sup>2</sup>, 213 psi) is 62 °C (144 °F). So the temperature (70 °C, 158 °F) of compressed gaseous refrigerant is higher than the boiling point (62 °C, 144 °F) and also higher than the surrounding air. Therefore, the gaseous refrigerant can be converted into liquid state, releasing heat until its temperature drops to the boiling point. For example, 1.47 MPa (15 kgf/cm<sup>2</sup>, 213 psi), 70 °C (158 °F) gaseous refrigerant can be liquefied by lowering the temperature by approx. 8 °C (46 °F).

12190M00080

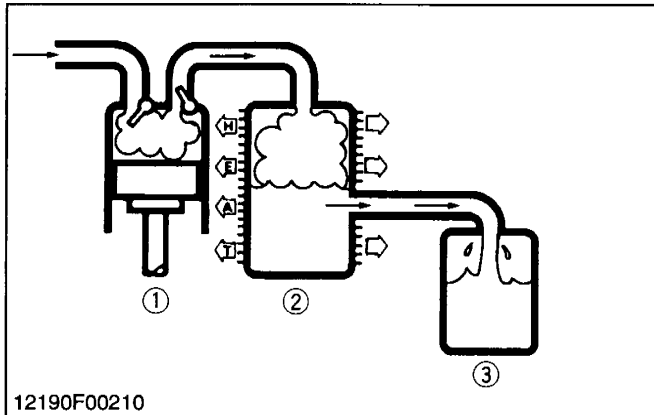
**(1)-3 Condensing Gaseous**

In the mechanical refrigeration system, the liquefaction of refrigerant is achieved by raising the pressure and then by lowering the temperature. The gaseous refrigerant which leaves the evaporator is compressed by the compressor (1). In the condenser (2) the compressed gaseous refrigerant releases heat to the surrounding air and it condenses back into liquid. And then the liquid refrigerant returns to the receiver (3).

- |                |              |
|----------------|--------------|
| (1) Compressor | (3) Receiver |
| (2) Condenser  |              |

12190M00090

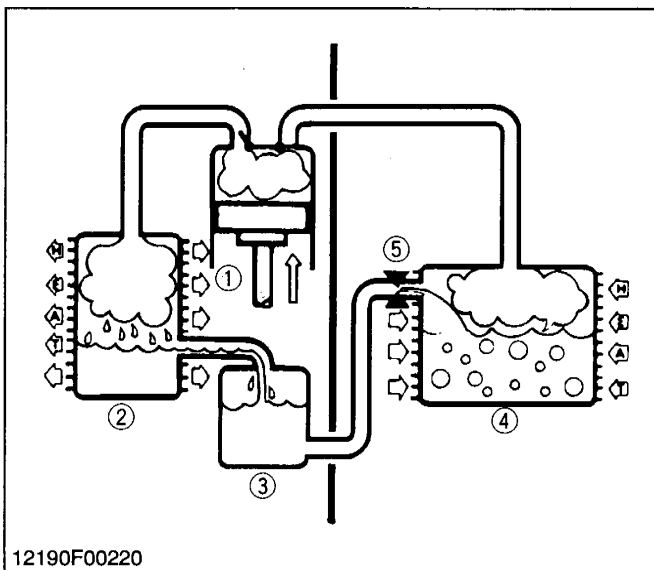
**(1)-4 Refrigeration Cycle**

1. The compressor (1) discharges high temperature and high pressure refrigerant that contains the heat absorbed from the evaporator (4) plus the heat created by the compressor in a discharge stroke.
2. This gaseous refrigerant flows into the condenser (2). In the condenser, the gaseous refrigerant condenses into liquid refrigerant.
3. This liquid refrigerant flows into the receiver (3) which stores and filters the liquid refrigerant till the evaporator requires the refrigerant.
4. By the expansion valve (5), the liquid refrigerant changes into low temperature, low pressure liquid and gaseous mixture.
5. This cold and foggy refrigerant flows to evaporator. Vaporizing the liquid in the evaporator, the heat from the warm air steam passing through the evaporator core is transferred to the refrigerant.

All the liquid will change into gaseous refrigerant in the evaporator and only heat-laden gaseous refrigerant is drawn into the compressor. Then the process is repeated again.

- |                |                     |
|----------------|---------------------|
| (1) Compressor | (4) Evaporator      |
| (2) Condenser  | (5) Expansion Valve |
| (3) Receiver   |                     |

12190M00100

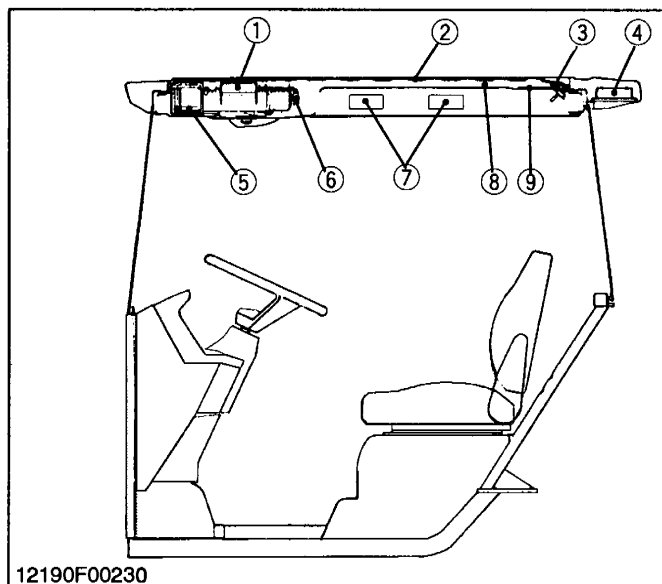
**(2) Outline of Air Conditioning System**

The machine is equipped with a thin large-capacity air conditioner with outside air intake. Through the inside air filter (9) as well as the outside air filter (4), the air flows along between the outer roof (2) and the inner roof (8) and reaches the air conditioner unit (1). The air is then cooled and dehumidified by this unit.

The resulting air is heated to a comfortable level. In this way, the air being blown via the blow port can be kept at comfortable temperature and humidity.

The 3 front blow ports (5) can be opened and closed using the center knob of each port. The 4 side blow ports (7) are opened and closed using the mode lever on the control panel (6). With these ports open or closed, you can feel your head cool and your feet warm.

Capacity (Cooling)	Factory spec.	2.10 to 2.56 kw
Capacity (Warming)	Factory spec.	3.14 to 3.84 kw
Kinds of refrigerant (Charge amount)	Factory spec.	R134a 0.9 to 1.0 kg 1.98 to 2.21 lbs.
Pressure sensor (Low)	Factory spec.	0.196 MPa 2.0 kgf/cm <sup>2</sup> 28.4 psi
Pressure sensor (High)	Factory spec.	3.14 MPa 32.0 kgf/cm <sup>2</sup> 455 psi

- |   |                       |
|---|-----------------------|
| (1) Air Conditioner Unit                | (5) Front Blow Port   |
| (2) Outer Roof                          | (6) Control Panel     |
| (3) Inside/Outside Air Selection Damper | (7) Side Blow Port    |
| (4) Outside Air Filter                  | (8) Inner Roof        |
|   | (9) Inside Air Filter |

12190M00110

### (3) Refrigeration System

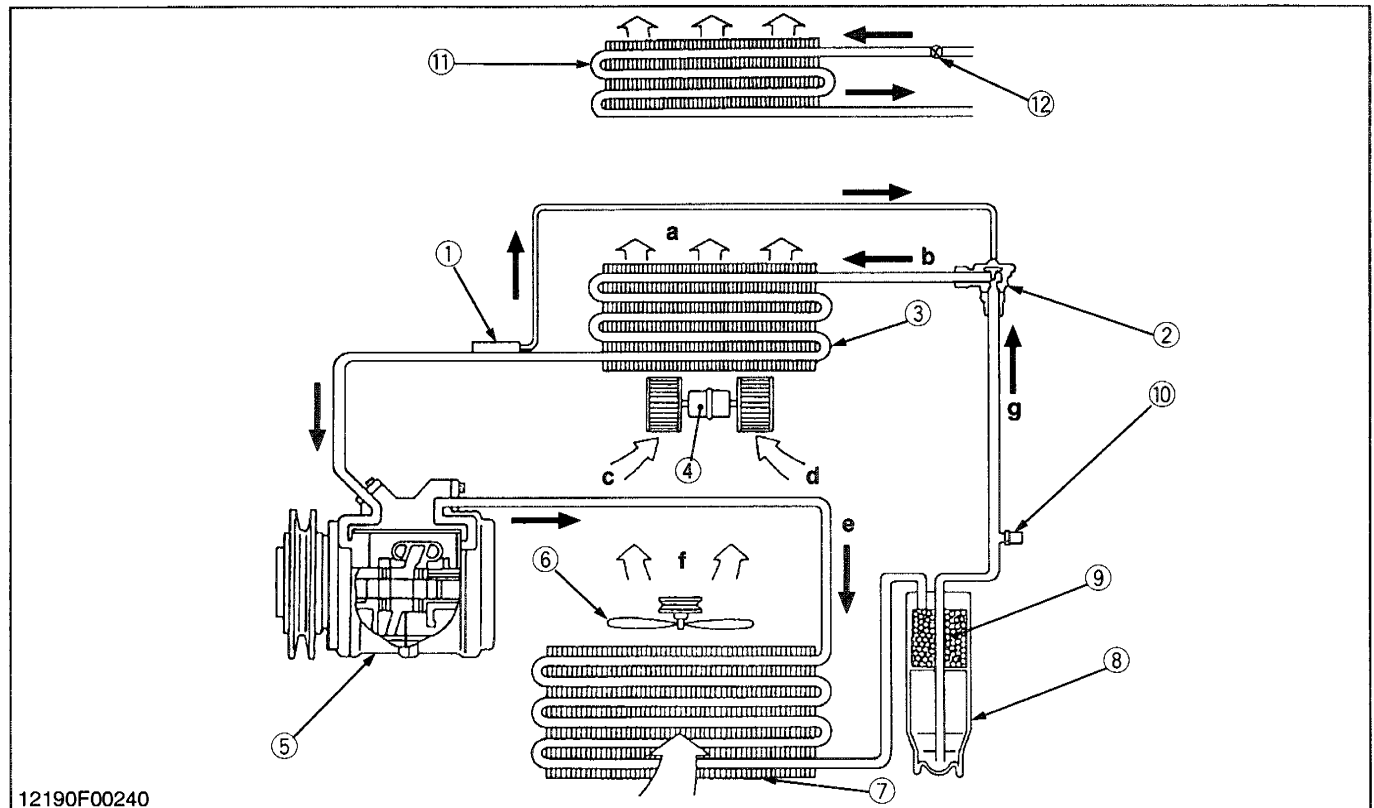

12190F00240

- |                           |                      |  |   |
|---------------------------|----------------------|--|---|
| (1) Heat Sensitizing Tube | (7) Condenser        | (a) Cold Air                           | (e) High Pressure, High Temperature Gas |
| (2) Expansion valve       | (8) Receiver         | (b) Low Pressure, Low Temperature Mist | (f) Hot Air                             |
| (3) Evaporator            | (9) Desiccant        | (c) Cabin Interior Air                 | (g) Liquid                              |
| (4) Blower Motor          | (10) Pressure Switch | (d) Cabin Interior Air                 |   |
| (5) Compressor            | (11) Heater Core     |  |   |
| (6) Engine Cooling Fan    | (12) Water Valve     |  |   |

The refrigerant cycle of air conditioning system is as follows.

- The gaseous refrigerant evaporated through the evaporator (3) is compressed in the compressor (5) to approx. 1.47 MPa (15 kgf/cm<sup>2</sup>, 213 psi) and is also raised in temperature to approx. 70 °C (158 °F) and delivered to the condenser (7).
- The gaseous refrigerant is cooled down through the condenser (7) to approx. 50 °C (122 °F) and delivered to the receiver (8) in the liquid state. At this time, heat removed from the cabin interior is extracted by means of the condenser (7).
- The liquid refrigerant is collected in the receiver (8) for a certain period. At this time moisture are removed from the refrigerant by desiccant (9).
- The liquid refrigerant after removing moisture and dust is jetted out of the small hole of the expansion valve (2) into the evaporator (3) as if it were distributed by an atomizer. Thus, the refrigerant is reduced in both pressure and temperature, and becomes easy to evaporate.
- The refrigerant evaporates at 0 °C (32 °F) vigorously, taking heat from the surface of the pipes in the evaporator (3).

- At this time, warm air in a cabin is drawn into the evaporator (3) by the blower motor and is passed over those pipes, transferring its heat to the refrigerant for evaporation. The air thus cooled is distributed to the cabin. (That is heat in a cabin is taken by the evaporator.)

#### (Reference)

- Since warm air in a cabin is cooled suddenly, water in the air is liquefied and removed, which means dehumidification is also performed.
- The gaseous refrigerant from the evaporator (3) after having performed the cooling action is returned to the compressor (5), and is compressed to liquefy it (high pressure and high temperature). This cycle is repeated.
  - The air coming from the evaporator is fed to the air mixing doors, by which part of the air is introduced into the heater core (11). In doing so, the air temperature can be adjusted to a comfortable level. The air mixing doors are controlled through the cable connected with the control panel.

12190M00120

**(3)-1 Compressor**

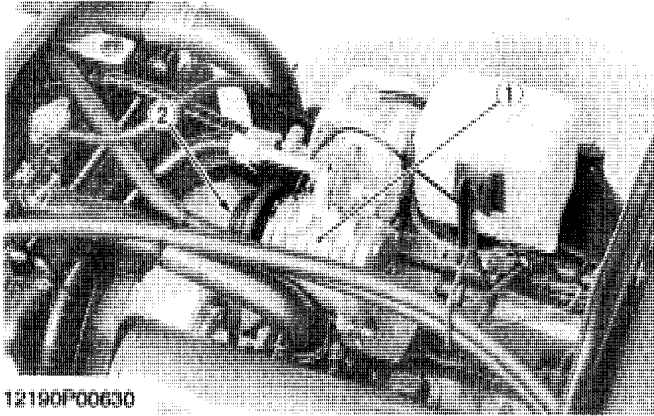

12190F00630

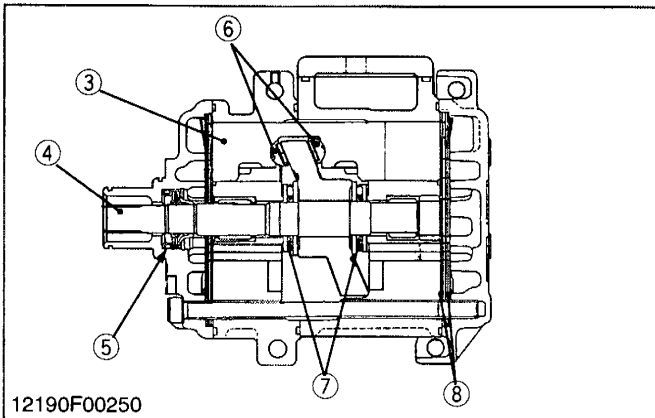

12190F00250

The compressor (1) is installed to on the engine and is driven by crank pulley through a belt.

The compressor is a pump designed to raise the pressure of refrigerant. Raising the pressure means raising the temperature. High temperature refrigerant vapor will condense rapidly in the condenser by releasing heat to the surrounding.

Compressors are roughly classified into two types; reciprocating type and swash plate type. This air conditioner system adopts swash plate type compressor.

**■ Swash Plate Type Compressor**

A number of paired piston at set on the swash plate in an interval of 72 degrees for 10 cylinders compressor. When one side of a piston is in a compression stroke, the other is in a suction stroke.

- |                     |                                 |
|---------------------|---------------------------------|
| (1) Compressor      | (5) Shaft Seal                  |
| (2) Magnetic Clutch | (6) Ceramic Shoe                |
| (3) Piston          | (7) Thrust Bearing              |
| (4) Shaft           | (8) Suction and Discharge Valve |

12190M00130

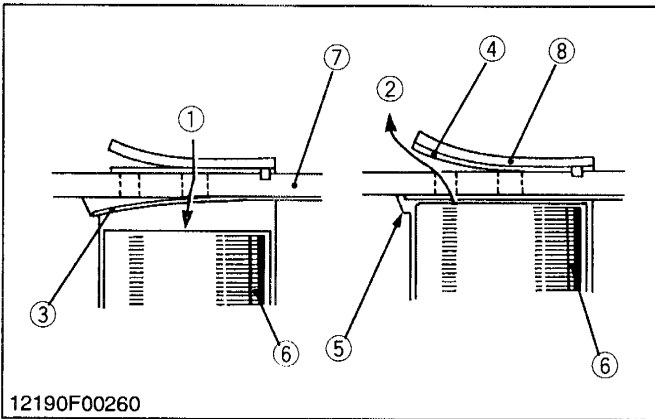

12190F00260

When the pressure inside piston becomes negative as the piston is lowered, the low pressure gas flows through the suction hole of the valve plate (7) to force down the suction valve (3), thereby sending refrigerant into each cylinder. The deflecting width of the suction valve (3) is determined by the notch in the cylinder (suction valve stopper) (5). When the piston goes into the compression stroke and the pressure exceeds that of high pressure side, the discharge valve (4) is pushed up to send out the high pressure gas from the compressor.

After the compression stroke is completed and the piston goes into the suction stroke, the high pressure gas on the discharge side holds the discharge valve to prevent the back flow of the gas from the high pressure side. In this way, the difference of high and low pressure can be maintained inside of the compressor.

The R type compressor has 5 pairs (10 cylinders) of pistons secured to the swash plate which is secured diagonally on the shaft. As the shaft rotates, the piston (6) reciprocates in the same direction as the shaft. Cylinders are arranged respectively on both sides of a pair of pistons and when the cylinder on one side is in compression stroke, the cylinder on the other side goes into suction stroke.

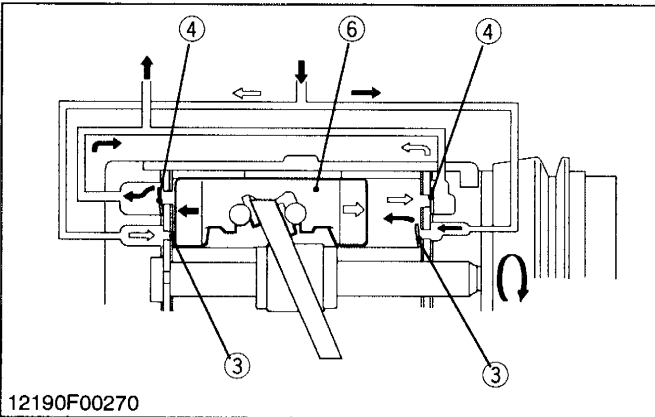

12190F00270

- |                     |                 |
|---------------------|-----------------|
| (1) Suction         | (5) Notch       |
| (2) Discharge       | (6) Piston      |
| (3) Suction Valve   | (7) Valve Plate |
| (4) Discharge Valve | (8) Retainer    |

12190M00140



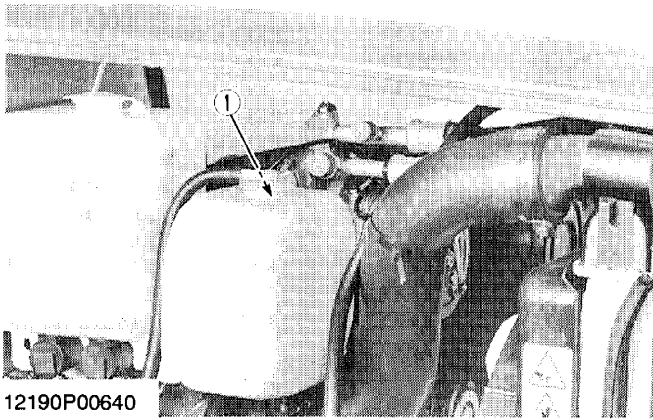

12190P00640

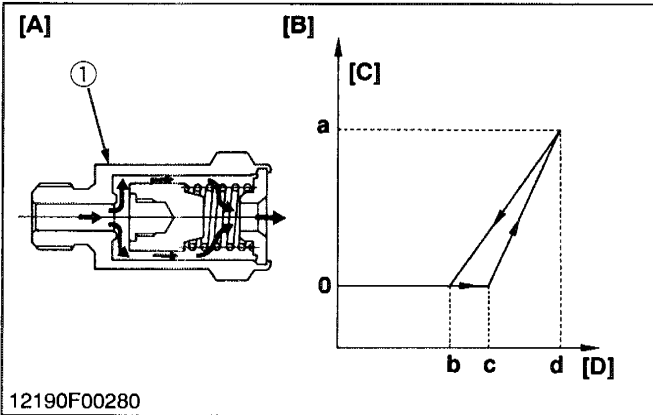

12190F00280

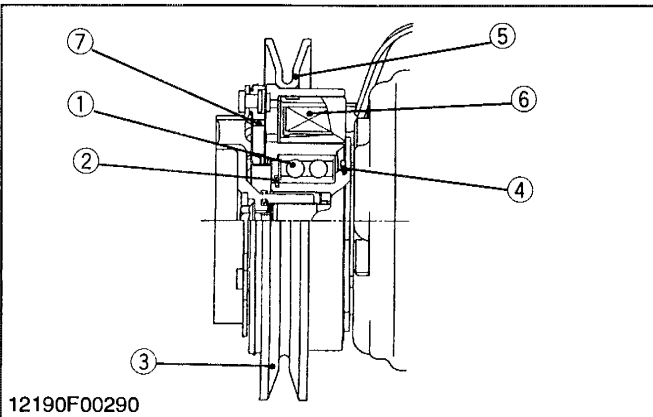

12190F00290

If the high pressure is abnormally high, the melt bolt dissolves, and the refrigerant is released into the atmosphere, and the system is maintained. At the time, all of the refrigerant in the system is released into the atmosphere.

Even in the worst case, the outflow of refrigerant is stopped at the minimum limit.

**(Reference)**

- In normal operation, the high pressure switch is triggered first and the compressor stops, so the pressure relief valve is not triggered so easily.

- |  |                                       |
|--|---------------------------------------|
| (1) Pressure Relief Valve                          | (A) Gas Ejection Route When Operating |
| (a) 113 (L/min.)                                   | (B) Operator Characteristic           |
| (b) 2.76 MPa, 28.1 kgf/cm <sup>2</sup> , 399.7 psi | (C) Leakage Quantity                  |
| (c) 3.43 MPa, 35.0 kgf/cm <sup>2</sup> , 497.8 psi | (D) Pressure                          |
| (d) 4.14 MPa, 42.4 kgf/cm <sup>2</sup> , 603.1 psi |                                       |

12190M00150

A magnetic clutch is used to engage and disengage the compressor from the engine. Main components are stator (6) and rotor with pulley (5), and pressure plate (7) to engage the drive pulley (3) and compressor magnetically.

The stator is fixed on the compressor housing, and the pressure plate is attached to the compressor shaft. Two ball bearings are used between the inner surface of the rotor and the front housing of the compressor.

- |                  |                      |
|------------------|----------------------|
| (1) Ball Bearing | (5) Rotor W / Pulley |
| (2) Snap Ring    | (6) Stator           |
| (3) Pulley       | (7) Pressure Plate   |
| (4) Snap Ring    |                      |

12190M00160

**Compressor Oil**

The compressor oil dissolves in the refrigerant, circulates through the air-conditioning cycle, and functions to lubricate the compressor. But the conventional compressor oil for R12 doesn't dissolve in R134a, so it doesn't circulate through the cycle, and the lifespan of the compressor is considerably shortened.

It is still essential to ensure that the correct refrigerant oil is used. R12 systems were lubricated with mineral oil, which is totally unsuitable for R134a systems. The latter require PAG oil, which mixes very well with the refrigerant and provides ideal lubrication throughout the system.

Quality (Total)	Brand Name
200 cm <sup>3</sup> 12.2 cu.in.	ND-OIL 8 <PAG* oil>

\*PAG : Polyalkyleneglycol (Synthetic oil)

12190M00170

**(3)-2 Condenser**

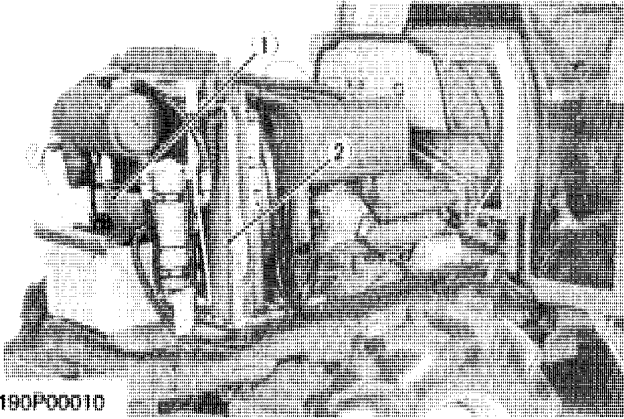

12190P00010

The condenser (1) is installed to the front of radiator (2) to enable forcible cooling by the air drawn in by the engine radiator fan.

The condenser is used for the purpose of cooling and robbing the heat from the refrigerant gas, which has been compressed by the compressor into high temperature, high pressure gas, so as to change this gas into liquid refrigerant.

The heat given off by the gaseous refrigerant in the condenser is the sum of the heat absorbed at the evaporator and the heat of work required by the compressor to compress the refrigerant. The greater the amount of heat give off in the condenser, the greater will be the cooling effect attainable by the evaporator.

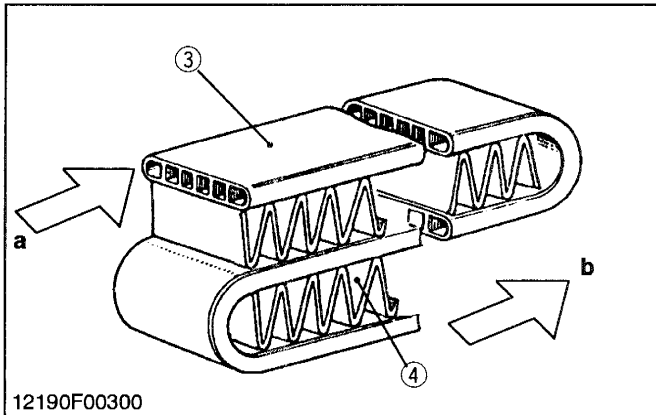

12190F00300

- (1) Condenser
- (2) Radiator
- (3) Tube
- (4) Fin
- (5) Vapor
- (6) Liquefying
- (7) Liquefied

- (a) Gaseous Refrigerant
- (b) Liquid Refrigerant
- (c) Heated Vapor from Compressor (70 °C, 158 °F)
- (d) Cooled Liquid to Receiver

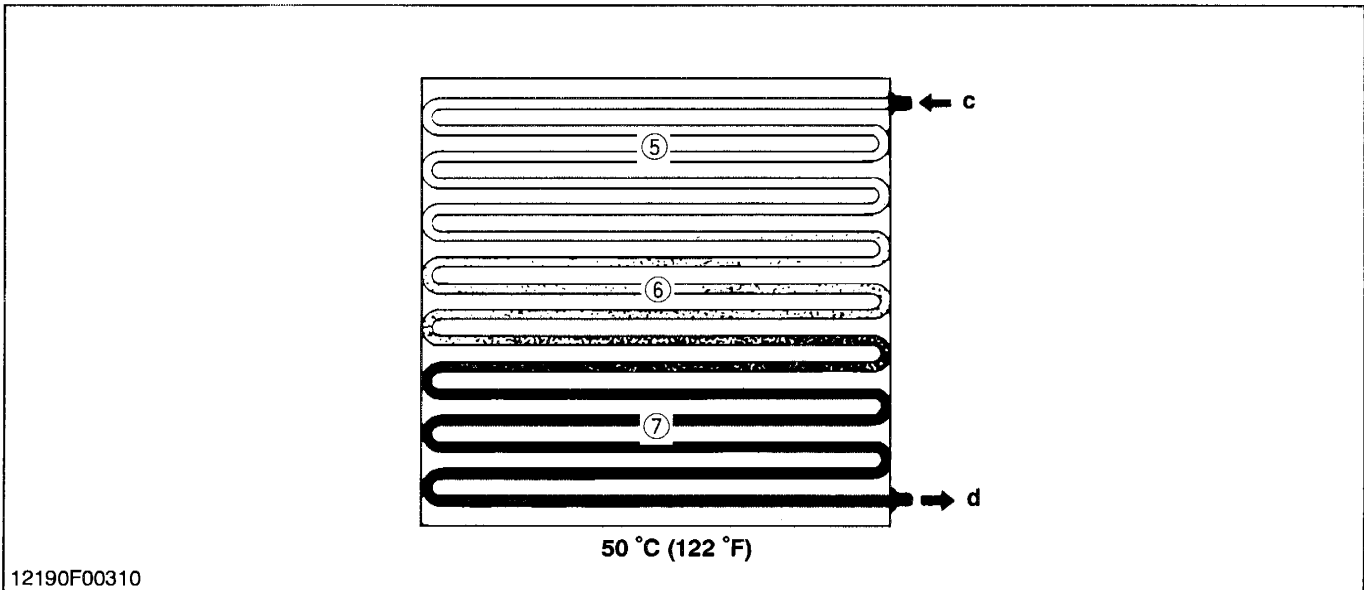

12190F00310

12190M00180

**(3)-3 Receiver**

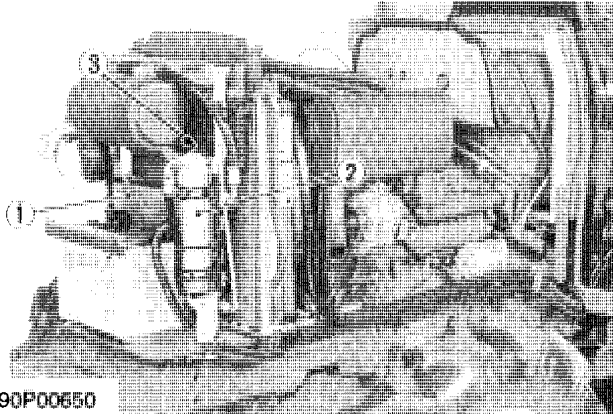

12190P00650

The receiver (2) serves the purpose of storing the liquid refrigerant. The amount of the liquid refrigerant flowing through the system varies with the operating condition of the air conditioner. To be accurate, the receiver stores excess amount of refrigerant when the heat load is lowered. It also releases stored refrigerant when additional cooling is needed, thus, maintaining the optimum flow of refrigerant within the system.

The receiver includes a desiccant (5). It has the job of removing moisture as the refrigerant circulates within the system.

The sight glass (3) is installed on the top of receiver. Amount of refrigerant to be charged is very important for the efficiency of air conditioner. The sight glass is used to check the amount of refrigerant. If large flow of bubbles can be seen in the sight glass, there is insufficient refrigerant charged. If so, replenish the refrigerant to the proper level.

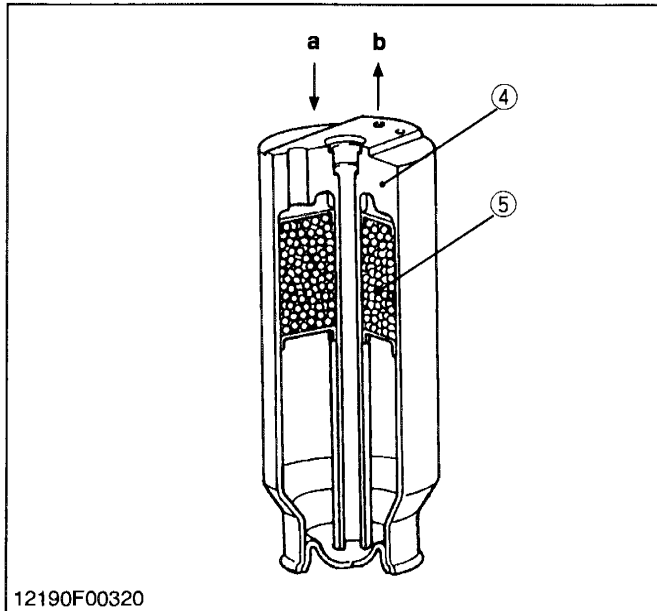

12190F00320

- |                   |         |
|-------------------|---------|
| (1) Condenser     | (a) IN  |
| (2) Receiver      | (b) OUT |
| (3) Sight Glass   |         |
| (4) Receiver Body |         |
| (5) Desiccant     |         |

12190M00190

**(3)-4 Air Conditioner Unit**

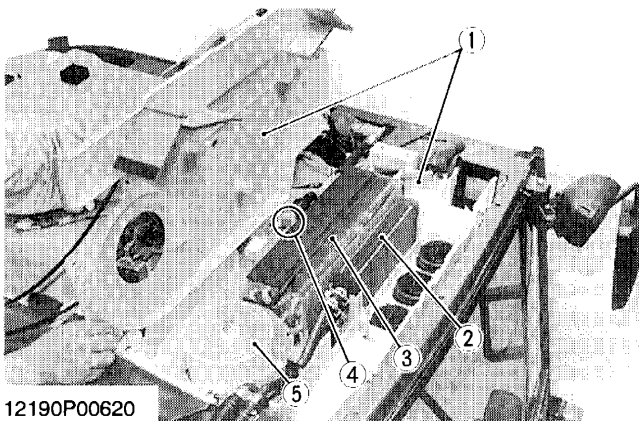

12190P00620

Air conditioner unit (1) consists of evaporator (3), expansion valve (4), heater core (2), blower (5), etc.

- |                          |                     |
|--------------------------|---------------------|
| (1) Air Conditioner Unit | (4) Expansion Valve |
| (2) Heater Core          | (5) Blower          |
| (3) Evaporator           |                     |

12190M00200

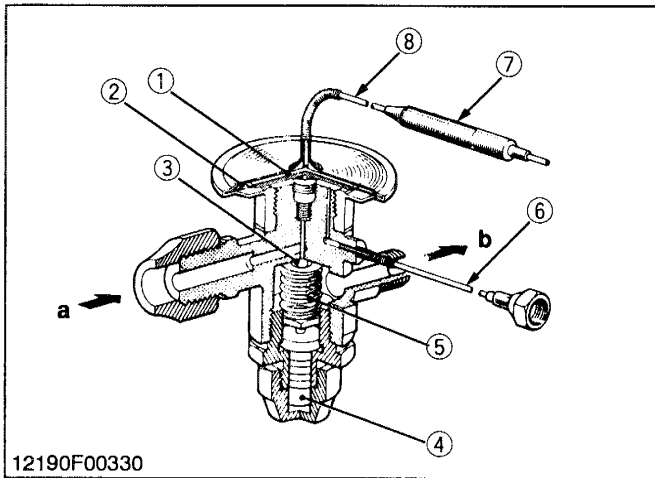

**Expansion Valve**

The expansion valve restricts the flow of liquid refrigerant as it passes through the expansion valve and delivers sprayed refrigerant to the evaporator for facilitating refrigerant evaporation.

The cabin interior will not be cooled sufficiently if the expansion valve outlet is too small. If it is too wide, frost will be produced on the evaporator, decreasing cooling efficiency. Thus the size of this small spray hole has to be controlled according to various conditions.

- |                           |                     |
|---------------------------|---------------------|
| (1) Diaphragm Chamber     | (a) From Receiver   |
| (2) Diaphragm             | (b) To Evaporator   |
| (3) Needle Valve          | (c) From Evaporator |
| (4) Adjusting Screw       | (d) To Compressor   |
| (5) Pressure Spring       |                     |
| (6) Tube                  |                     |
| (7) Heat Sensitizing Tube |                     |
| (8) Capillary Tube        |                     |

12190M00210

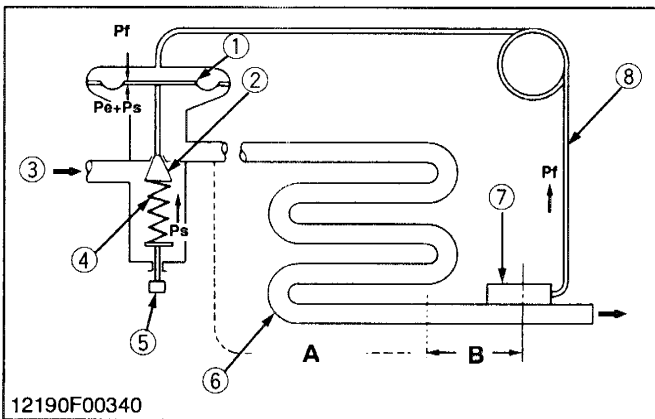

When the vapor pressure of the operating system is stable,  $P_f = P_e + P_s$  condition will prevail. The needle valve opening at this time will be stationary and constant refrigerant flow will be maintained.

In the evaporator installing expansion valve, the refrigerant in the outlet is always in superheated vapor form for a certain length (part B in the figure). If the cooling load increases (inlet air temperature of evaporator becomes high), the refrigerant will vaporize faster and cause the length of the superheated vapor part L to become longer. Thus, the pressure in the heat sensitizing tube (7) rises and increases the needle valve opening, resulting in larger flow of the refrigerant into evaporator. Conversely, if the amount of refrigerant in the evaporator becomes greater, the length of the superheated vapor part L will become shorter. The pressure in the heat sensitizing tube will drop and decrease the needle valve (2) opening.

- |                           |  |
|---------------------------|--|
| (1) Diaphragm             | (A) Saturated Vapor Part                 |
| (2) Needle Valve          | (B) Superheated Vapor Part L             |
| (3) Refrigerant Inlet     | $P_f$ : Gas pressure in sensitizing tube |
| (4) Spring                |  |
| (5) Adjusting Screw       | $P_s$ : Spring pressure                  |
| (6) Evaporator Tube       | $P_e$ : Vapor pressure in evaporator     |
| (7) Heat Sensitizing Tube |  |
| (8) Capillary Tube        |  |

12190M00220

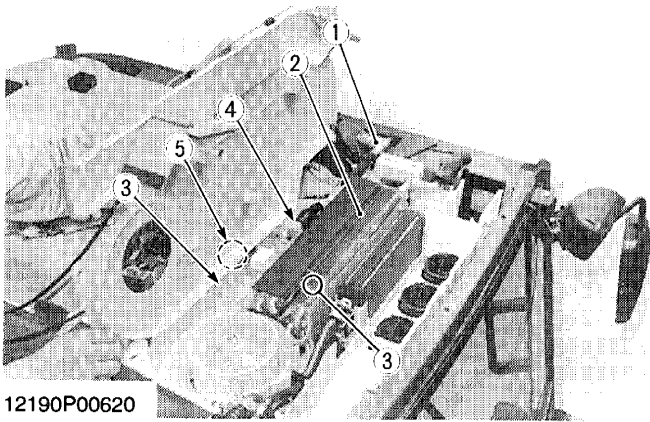

12190P00620

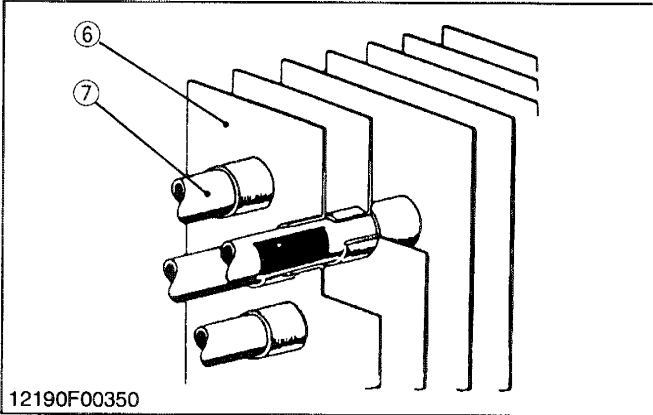

12190F00350

**Evaporator**

The purpose of evaporator (2) is just opposite to that of the condenser. The state of refrigerant immediately after the expansion valve (3) is 100 % liquid. As soon as the liquid pressure drops, it starts to boil, and in doing so, absorbs heat. This heat is removed from the air passing over the cooling fins of the evaporator and causes the air to cool.

If too much refrigerant is sent into the evaporator, it will not boil away so easily. Also, the evaporator filled with liquid refrigerant eliminates a place for the refrigerant to properly vaporize, which is necessary in order to take on heat. A flooding condition of the evaporator will allow an excess of liquid refrigerant to leave the evaporator and may cause serious damage to the compressor.

If too little refrigerant is sent into the evaporator, again the evaporator will not cool because the refrigerant will vaporize, or boil off, long before it passes through the evaporator.

Refrigerant properly metered into the evaporator should allow for 100 % liquid just after the expansion valve, and 100 % gas at the outlet.

- |                     |                |
|---------------------|----------------|
| (1) Pressure Switch | (5) Thermostat |
| (2) Evaporator      | (6) Fin        |
| (3) Capillary Tube  | (7) Tube       |
| (4) Expansion Valve |                |

12190M00230

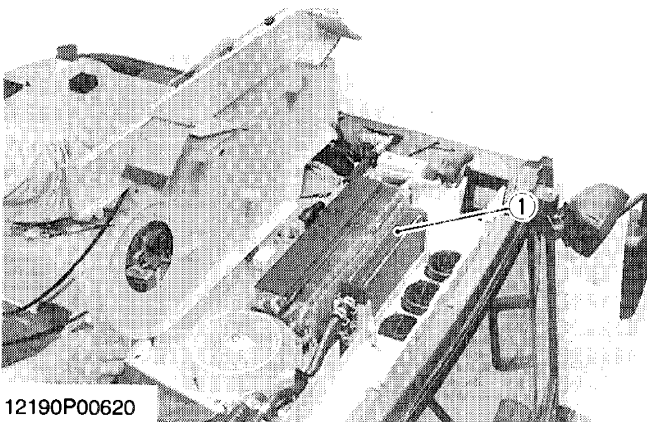

12190P00620

**Heater Core**

The heater-core of heater utilizes cooling water which becomes high temperature by heat of engine.

The inlet port of heater core is connected to the delivery side of engine water pump by a rubber hose, and the water valve is installed on the inlet port of heater core. Also, the outlet port of heater core is connected to the engine cylinder block.

The heater core is one of the heat exchangers like evaporator or condenser, and heat is exchanged between heated cooling water passing through the core and air in the cabin or fresh outdoor air. Thus, air is heated.

- (1) Heater Core

12190M00240

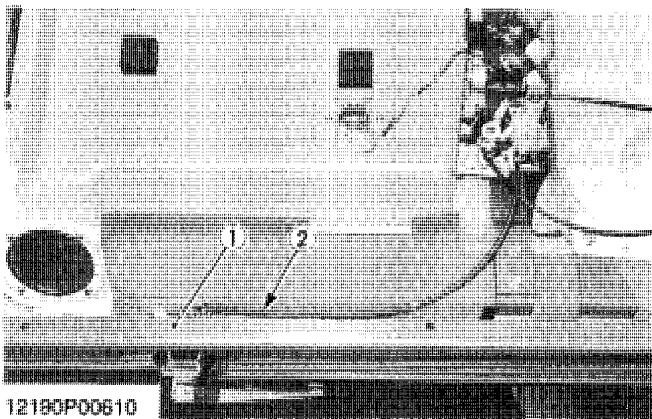

12190P00610

**Water Valve**

The hot water valve (1) is connected with the hot water valve cable (2) and controlled with the temperature control lever on the control panel. This lever is used to adjust the flow rate of hot water going into the heater.

Set the temperature control lever to the **COOL** position and the hot water valve gets closed, allowing no hot water flow. The hot water valve is built in at the right-hand top of the center pillar.

- (1) Hot Water Valve                      (2) Hot Water Valve Cable

12190M00250

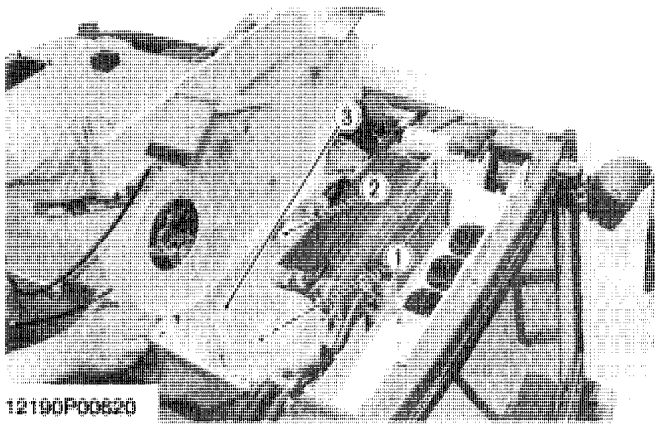

12190P00620

### ■ A/C Blower

The blower is incorporated in the right-hand space of the air conditioner unit. It blows cool, warm or fresh air via the front and side blow ports into the cabin.

The speed of the blower motor (1) can be adjusted in 3 steps by the resistor (2).

The blower fan (3) is of centrifugal type. The air being sucked in parallel with the rotary shaft is blown in the centrifugal direction; in other words, perpendicular to the rotary shaft.

- (1) Blower Motor  
(2) Resistor

- (3) Blower Fan

12190M00260

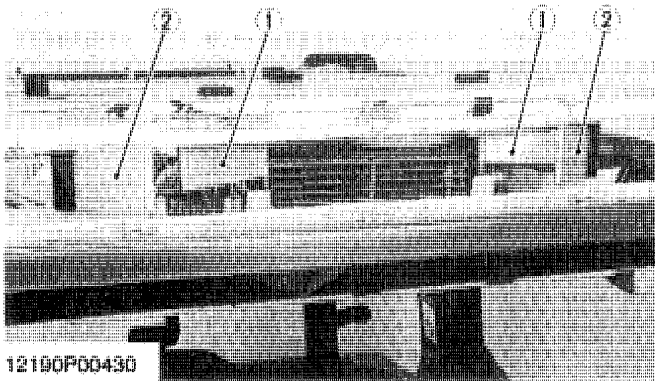

12190P00430

### ■ Air Mixed Door · Mode Door

The air mixing doors (1) are fit at both sides of the heater in the air conditioner unit. The temperature control lever on the control panel is used to open and close the doors. Set this lever to the rightmost (**WARM**) position, and the air mixing doors get fully closed. All the air that is passing through the evaporator is heated up and fed to the blow ports. As this lever moves to the left (toward the **COOL** position), the air mixing doors open themselves gradually. This means that there will be more air not being heated. The hot water valve gradually closes at the same time, and the blown-air temperature will drop accordingly. Most of the air that does not pass through the heater but comes through the air mixing doors is blown out of the side blow ports. This helps you feel your head cool and your feet warm.

The mode doors (2) are provided at the inlets of the ducts that run to the right- and left-side blow ports, and are used to open and close the side blow ports.

- (1) Air Mixing Door

- (2) Mode Door

12190M00270

### ■ Refrigerant R134a

#### ■ IMPORTANT

- The air conditioning system operates using R134a refrigerant. This substance does not contain any chlorine atoms, so it does not have a detrimental effect on the ozone in the Earth's atmosphere.
- Even so, the refrigerant must never be discharged straight into the air. It must be trapped in a recycling machine.  
Refrigerant stored in a recycling unit may be re-used at any time.
- The recycling machine used to do this must be of a type suitable for handling R134a refrigerant.
- R134a has a corrosive effect on copper as well as various seals and components used in the R12 system. For this reason, never use R134a refrigerant in a system that has previously used R12. Before replacing any component, it is vital to check whether it is compatible with the type of refrigerant used.

12190M00280

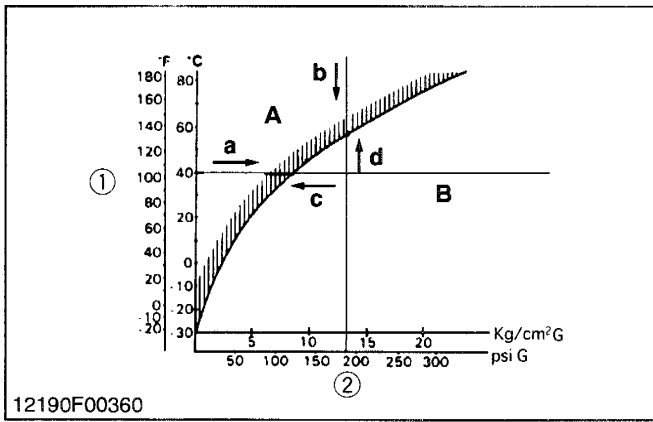

■ Refrigerant Properties

Water boils at 100 °C (212 °F) under atmospheric pressure, but R134a boils at - 26.5 °C (- 15.7 °F) and its freezing point is - 101 °C (-149.8 °F) below zero under atmospheric pressure.

If R134a were exposed and released to the air under normal room temperature and atmospheric pressure, it would absorb the heat from the surrounding air and boil immediately changing into gas. Also R134a is easily condensed back into liquid under the pressurized condition by removing heat from it.

The characteristic curve of R134a which expresses the relation between the temperature and pressure is shown in the figure left. The graph itself indicates the boiling point of R134a under each temperature and pressure. On the graph, the upper portion above the curve is gaseous state of R134a and the lower portion below the curve is liquid state of R134a. The gaseous refrigerant can be converted into the liquid refrigerant by raising the pressure without changing the temperature or decreasing the temperature without changing the pressure. (See (a) and (b) in the figure.) Conversely, the liquid refrigerant can be converted in to the gaseous refrigerant by lowering the pressure without changing the temperature, or by raising the temperature without changing the pressure. (See (c) and (d).)

- (1) Temperature (A) GAS
- (2) Gauge Pressure (B) LIQUID

12190M00290

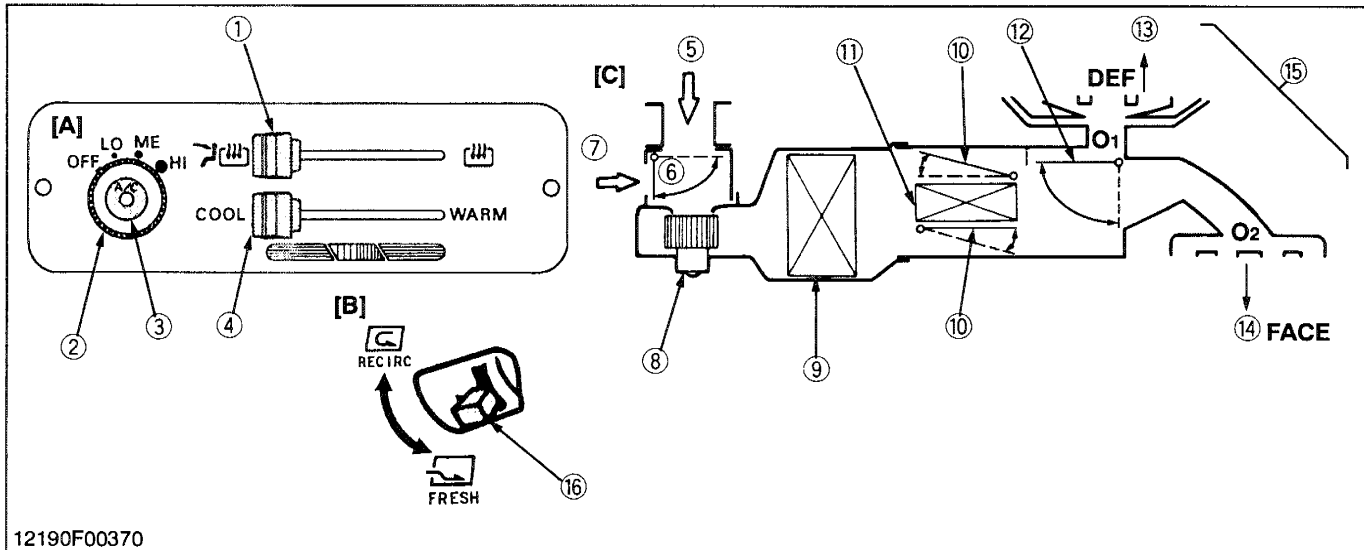
**(4) System Control**

- |                                    |   |   |                                       |
|------------------------------------|---|---|---------------------------------------|
| (1) Air Mode Lever                 | (7) Recirculated Air                                  | (12) Air Outlet Door D <sub>3</sub> (Mode Door) | (A) Control Plate                     |
| (2) Blower Switch                  | (8) Blower  | (13) DEF  | (B) Air Selection Lever               |
| (3) Air Conditioner Switch         | (9) Evaporator  | (14) FACE                                       | (C) Block Diagram of Air Flow Passage |
| (4) Temperature Control Lever      | (10) Temperature Door D <sub>2</sub> (Air Mixed Door) | (15) DEF and FACE                               |                                       |
| (5) Fresh Air                      | (11) Heater   | (16) Air Selection Lever                        |                                       |
| (6) Air Intake Door D <sub>1</sub> |   |   |                                       |

**1) Selection of recirculated air (7) or fresh air (5) is done with door D<sub>1</sub>.**

■ **RECIRC**

By setting the air selection lever (16) in rear control panel to **RECIRC** position, door D<sub>1</sub> (6) shuts the fresh air inlet port. Air inside the cabin is recirculated.

■ **FRESH**

By moving the air selection lever (16) to **FRESH** position, door D<sub>1</sub> opens the fresh air inlet port. Outside air comes into cabin.

**2) Temperature control of outlet air is done with door D<sub>2</sub>.**

■ **COOL**

By setting the temperature control lever (4) in control panel to **COOL** position, door D<sub>2</sub> (10) is moved to close water valve. The air flows to door D<sub>3</sub> (12) side without passing the heater core.

■ **WARM**

By moving the temperature lever to **WARM** position, door D<sub>2</sub> is moved to open water valve. The air flows to door D<sub>3</sub> (12) side passing through the heater core.

**3) Outlet air flow is controlled by door D<sub>3</sub>.**

Moving the air mode lever (1) opens and shuts door D<sub>3</sub> and establishes the air passage according to the lever position.

■ **DEF + FACE**

By moving the mode lever to **DEF + FACE** position, the door D<sub>3</sub> is moved to establish the air passages to outlets O<sub>1</sub> and O<sub>2</sub>. Air comes out from both outlets.

■ **DEF**

Moving the mode lever to **DEF** position, door D<sub>3</sub> is moved to set up the air passage to outlet O<sub>1</sub>. Air comes out from outlet O<sub>1</sub>.

O<sub>1</sub> : Front air outlet

O<sub>2</sub> : Side air outlet

12190M00300



**(5) Electrical System**

**(5)-1 Electrical Circuit**

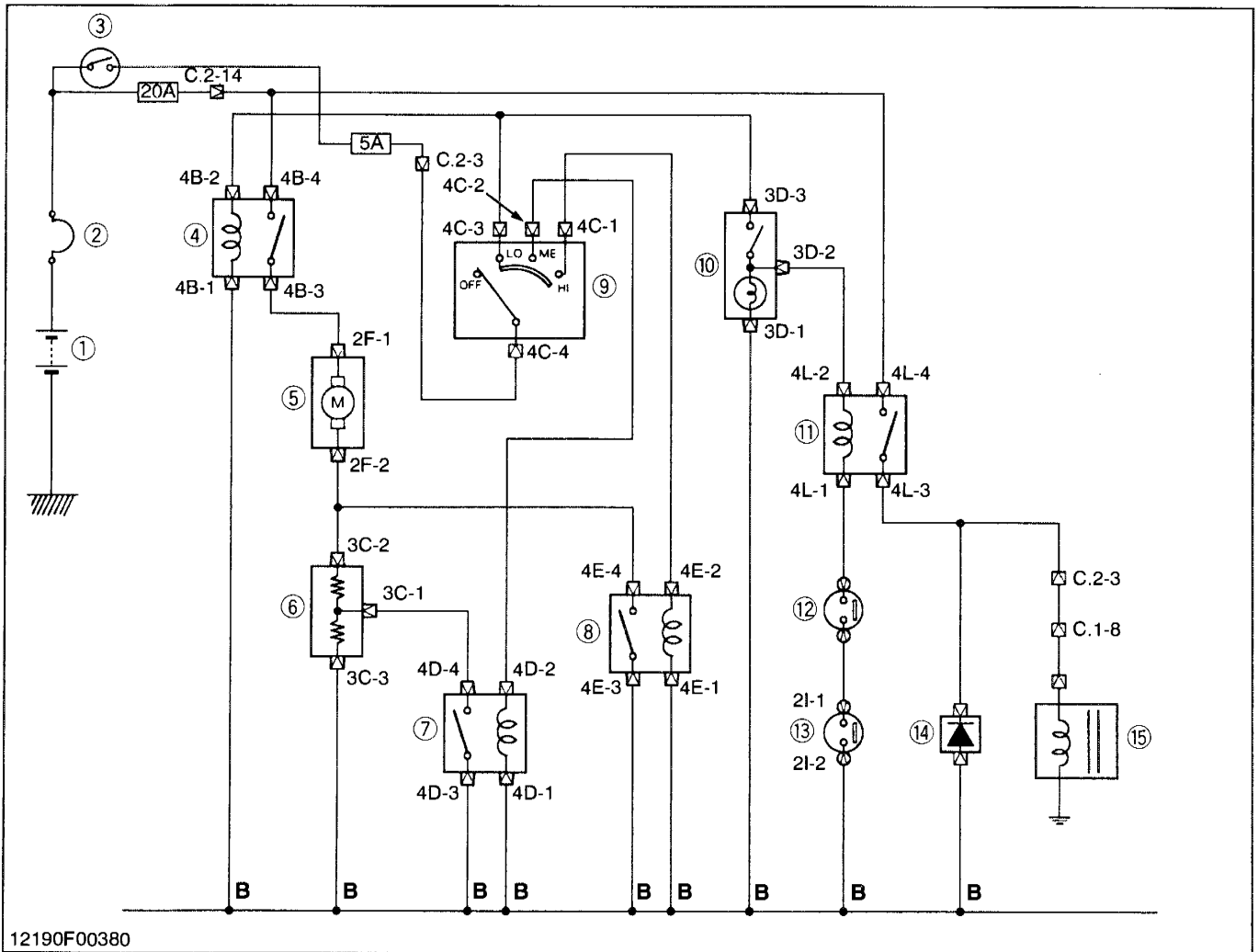

12190F00380

- |                    |                         |                       |                      |
|--------------------|-------------------------|-----------------------|----------------------|
| (1) Battery        | (5) A/C Blower Motor    | (9) A/C Blower Switch | (13) Pressure Switch |
| (2) Slow Blow Fuse | (6) A/C Blower Resistor | (10) A/C Switch       | (14) Diode           |
| (3) Main Switch    | (7) A/C Blower Relay 1  | (11) Compressor Relay | (15) Compressor      |
| (4) A/C Relay      | (8) A/C Blower Relay 2  | (12) Thermostat       |                      |

The process of magnetic clutch being engaged is shown below.

Main Switch (3) **ON** → A/C Blower Switch (9) **ON** (Low, Medium or High) → A/C Switch (10) **ON** → Compressor Relay (11) **ON** → Thermostat (12) **ON** (the thermostat temperature is more than 4 °C (39.2 °F)) → Pressure Switch (13) **ON** (if refrigerant pressure is between 0.21 MPa (2.1 kgf/cm<sup>2</sup>, 30 psi) and 265 MPa (27 kgf/cm<sup>2</sup>, 384 psi) → Magnetic Clutch of Compressor Engaged.

12190M00310

**(5)-2 Air Conditioner Relay, Blower Relays and Compressor Relay**

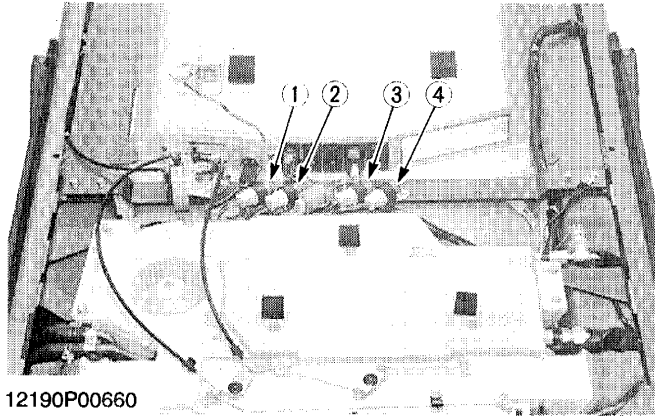

12190P00660

Remove the outer roof and the relays are visible at the ceiling center of the cabin : blower **HI** relay (1), **A/C** relay (Blower **LO** relay) (2), blower **ME** relay (3) and compressor relay (4). When the blower fan is adjusted for the air flow rate, the blower **HI** relay is activated by a signal from the fan switch on the control panel.

Among the air conditioner components, current flows to the blower motor and magnetic clutch. If all of these current were to be passed through the main switch and supplied, the current would be too large for the main switch so that there will be danger or burning out the main switch contact. If the current were to be passed directly from the battery, forgetting to turn off the blower motor could result in a discharged battery.

To protect against such trouble, relays have been provided. These relays have been made so that when current flows through its coil, the contact close to supply the power from the battery. By employing these relays, the current flowing through the main switch has been decreased as only a small current is required to actuate the relays. Thus there will be no danger of burning out the switch contact, and when the main switch is opened, the relay contact will open at the same time. This action stops the current flow in the air conditioner circuit so that there will also be no chance of the battery discharging.

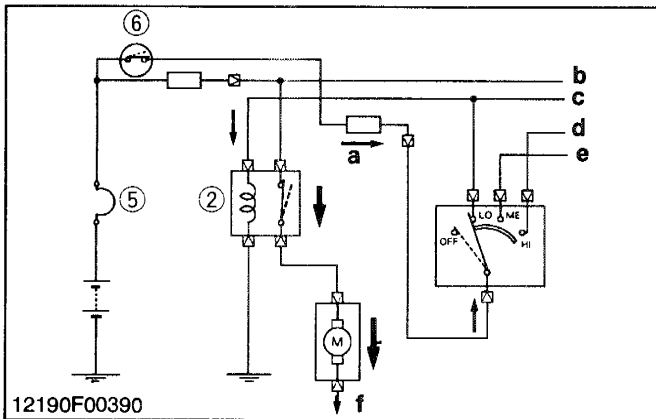

12190F00390

- |                                 |                         |
|---------------------------------|-------------------------|
| (1) Blower HI Relay             | (a) Small Current       |
| (2) A/C Relay (Blower LO Relay) | (b) To Compressor Relay |
| (3) Blower ME Relay             | (c) To A/C Switch       |
| (4) Compressor Relay            | (d) To Blower HI Relay  |
| (5) Battery                     | (e) To Blower ME Relay  |
| (6) Main Switch                 | (f) To Resistor         |

12190M00320

**(5)-3 Air Conditioner Blower Switch**

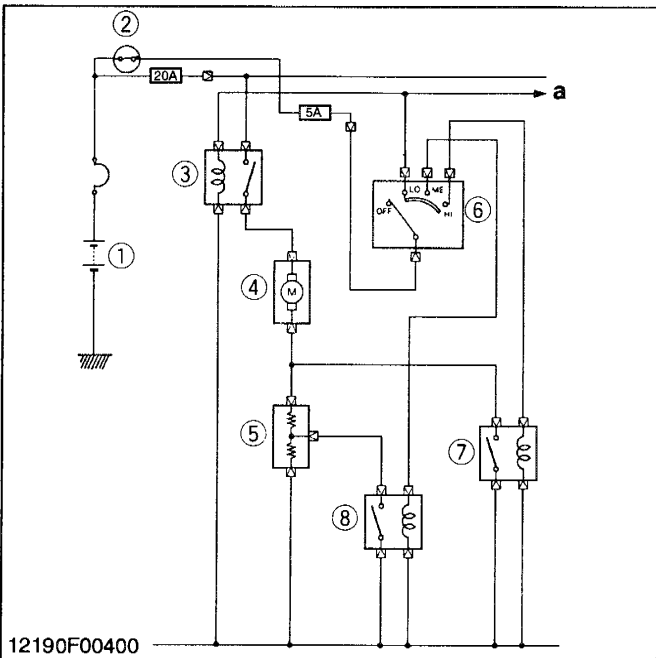

12190F00400

The wind of blower can be changed in 3 position (Low, Medium, High) by changing the air conditioner blower switch position.

**■ Air Conditioner Blower Switch is "OFF" Position**

When the air conditioner blower switch is in **OFF** position, even if the main switch is turned to **ON** position, air conditioner relay does not operate.

- |                           |                            |
|---------------------------|----------------------------|
| (1) Battery               | (6) A/C Blower Switch      |
| (2) Main Switch <b>ON</b> | (7) Blower <b>HI</b> Relay |
| (3) A/C Relay <b>OFF</b>  | (8) Blower <b>ME</b> Relay |
| (4) A/C Blower Motor      |                            |
| (5) Resistor              | (a) To A/C Switch          |

12190M00330

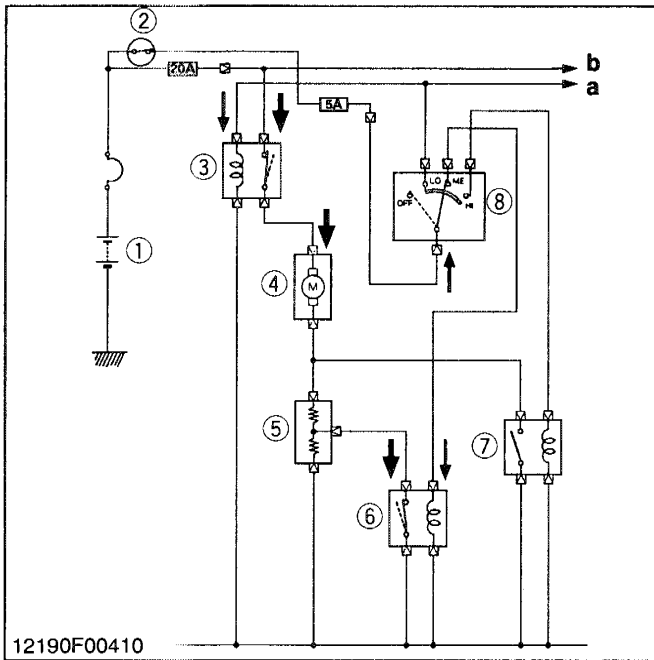

■ When Air Conditioner Blower Switch is in • (Low), ● (Medium) or ● (High) Position

When the main switch is turned **ON**, the current flows from battery to A/C relay's coil and A/C relay is turned **ON**. As the A/C relay is turned **ON**, the current from battery flows to A/C blower switch through the A/C blower motors as follows.

“•” (Low) Position

Battery → Slow Blow Fuse → Fuse → A/C Relay Contact (3) → Blower Motor (4) → Blower Resistor (5) → Ground.

“●” (Medium) Position

Battery → Slow Blow Fuse → Fuse → A/C Relay Contact (3) → Blower Motor (4) → Blower Resistor (5) → Blower ME Relay Contact (6) → Ground.

“●” (High) Position

Battery → Slow Blow Fuse → Fuse → A/C Relay Contact (3) → A/C Blower Motor (4) → Blower Relay Contact (7) → Ground.

- |                         |                             |
|-------------------------|-----------------------------|
| (1) Battery             | (7) A/C Blower HI Relay     |
| (2) Main Switch         | (8) A/C Blower Switch       |
| (3) A/C Relay           | (a) To A/C Switch           |
| (4) A/C Blower Motor    | (b) to A/C Compressor Relay |
| (5) Resistor            |                             |
| (6) A/C Blower ME Relay |                             |

12190M00340

(5)-4 Pressure Switch

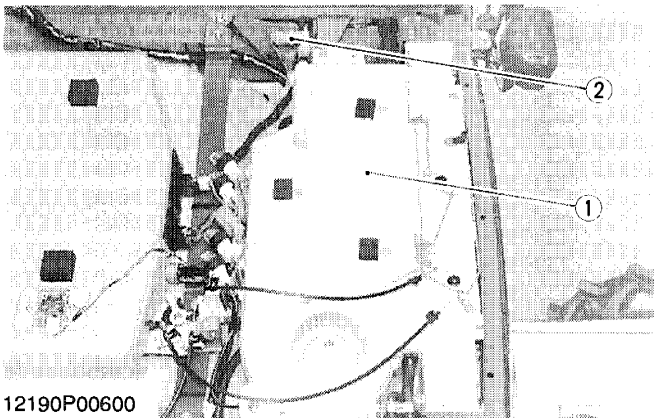

The pressure switch detects the pressure in the refrigerant cycle, and when something is wrong, turns off the magnetic clutch to prevent the component from troubling. This system has dual type pressure switch (2), and this switch controls low pressure cut and high pressure cut.

- |              |                     |
|--------------|---------------------|
| (1) A/C Unit | (2) Pressure Switch |
|--------------|---------------------|

12190M00350

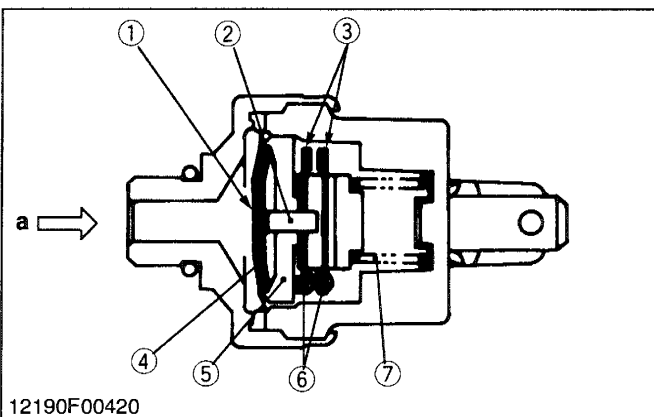

1) Pressure Switch (Dual Type)

The pressure switch is installed in inlet line (liquid line) between receiver and expansion valve.

The contact of pressure switch is normally open type.

- |                       |                     |
|-----------------------|---------------------|
| (1) Diaphragm         | (6) Movable Contact |
| (2) Pin               | (7) Spring          |
| (3) Terminal          |                     |
| (4) Belleville Spring | (a) Pressure        |
| (5) Plate             |                     |

12190M00360

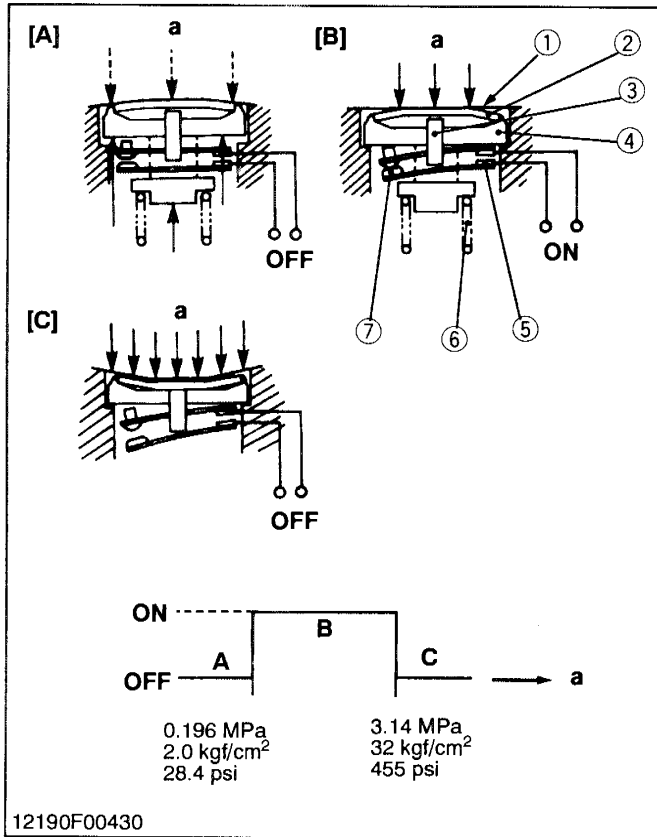

**OFF Position : A (When the Refrigerant Pressure is Low)**

The pressure switch detects the pressure drop when the refrigerant leaks from the system causing compressor seizure. When pressure of refrigerant is less than specified pressure, the switch is turned **OFF** and disengages magnetic clutch.

**ON Position : B (When the Refrigerant Pressure is Normal)**

When the pressure in the inlet line is between 0.196 MPa (2.0 kgf/cm<sup>2</sup>, 28.4 psi) and 3.14 MPa (32 kgf/cm<sup>2</sup>, 455 psi), the switch is turned **ON** (the pressure is normal condition), and engages magnetic clutch.

**OFF Position : C (When the Refrigerant Pressure is High)**

When the pressure in the inlet line is higher than specified pressure, the switch is turned **OFF**, and disengages magnetic clutch.

**(Reference)**

- Setting pressure
  - OFF (Low pressure side) :**  
Less than approx. 0.196 MPa (2.0 kgf/cm<sup>2</sup>, 28.4 psi)
  - ON (Normal pressure) :**  
Between approx. 0.196 MPa (2.0 kgf/cm<sup>2</sup>, 28.4 psi), to 3.14 MPa (32 kgf/cm<sup>2</sup>, 455 psi)
  - OFF (High pressure side) :**  
More than approx. 3.14 MPa (32 kgf/cm<sup>2</sup>, 445 psi)

- (1) Diaphragm
- (2) Belleville Spring
- (3) Pin
- (4) Plate
- (5) Terminal
- (6) Spring
- (7) Contact
- (a) Pressure

12190M00370

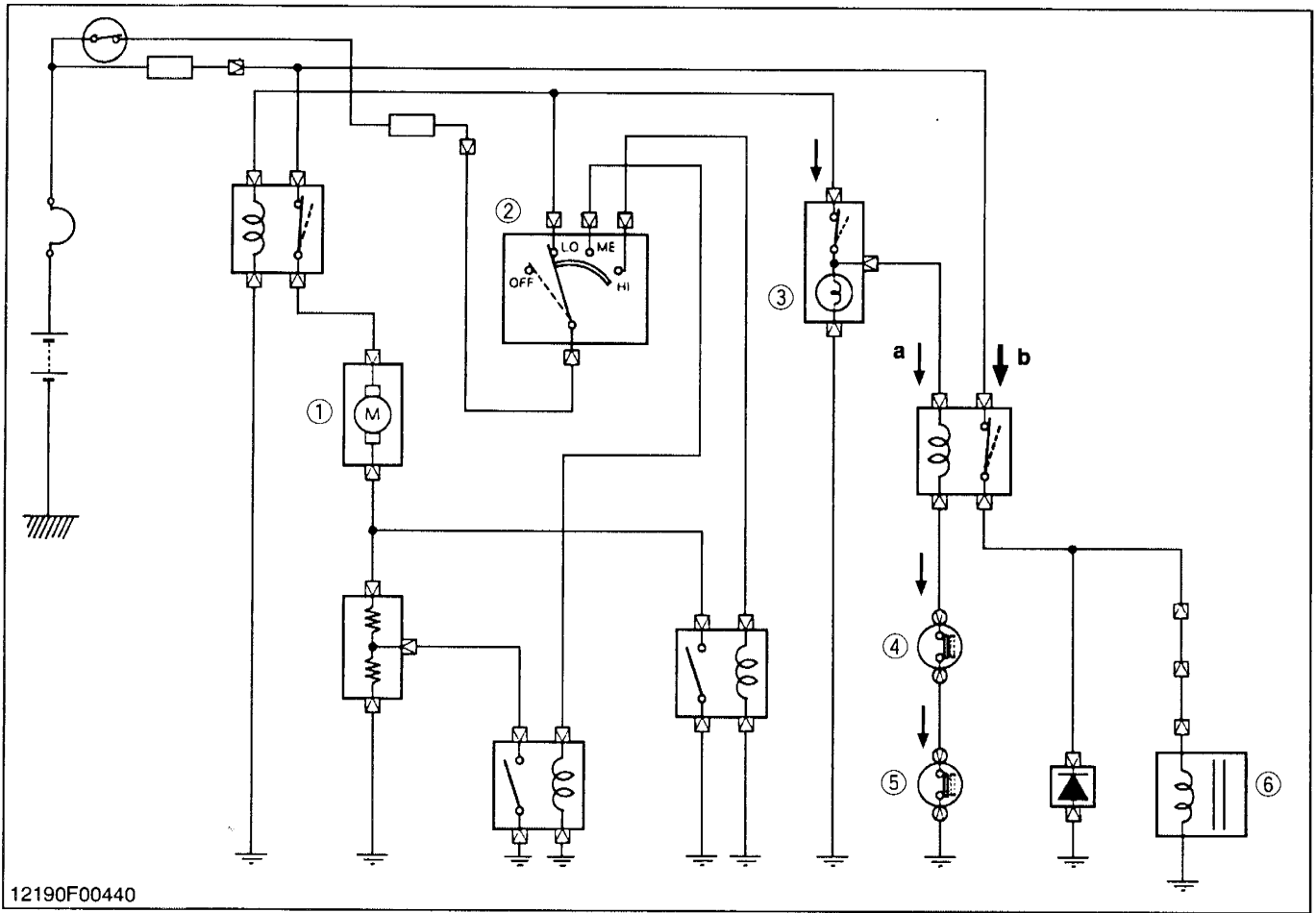

12190F00440

(1) A/C Blower Motor  
(2) A/C Blower Switch

(3) A/C Switch (ON)  
(4) Thermo Switch (ON)

(5) Pressure Switch (ON)  
(6) Magnetic Clutch

(a) Large Current  
(b) Small Current

**2) Circuit**

The circuit of magnetic clutch including the pressure switches is as shown in the figure. All switches are connected in series. The magnetic clutch can be turned

**ENGAGED** when the A/C blower switch and A/C switch are turned **ON** under the condition that both pressure switch and thermo switch are turned **ON**.

12190M00380

**(5)-5 Thermostat**

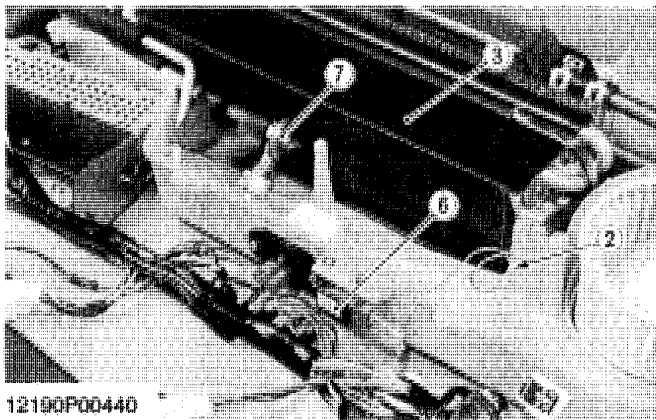
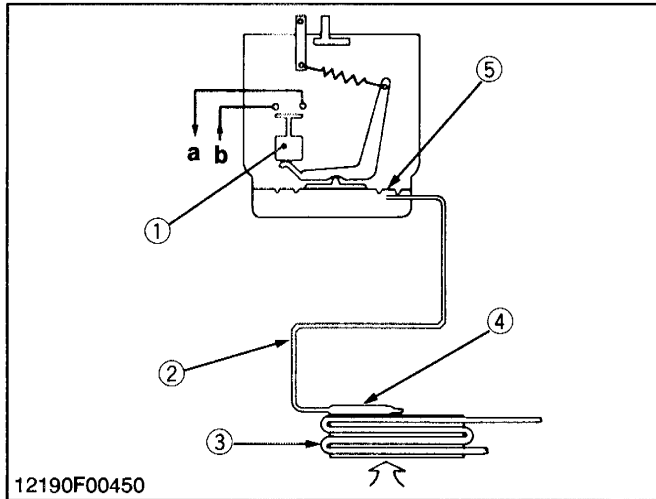

If the evaporator fin temperature, that is, refrigerant vaporizing temperature, drops below 0 °C (32 °F), frost or ice will form on the fins, causing a decrease in air flow and lowering cooling capacity. To prevent such frosting, and also to allow setting cabin interior to desired temperature, a thermostat has been installed.

In this system, gas type thermostat is used.

The gas type thermostat has a capillary tube which is filled with special gas. The capillary tube is connected to the diaphragm chamber. The tip of the capillary tube is positioned on the evaporator fins.

When the evaporator fins temperature is higher than setting temperature of the thermostat, the micro switch in the thermostat is turned **ON** by increasing the pressure in the diaphragm chamber. When the evaporator fins temperature is low, such as in winter season, the micro switch is turned **OFF** because of the pressure in the diaphragm chamber and spring tension drops, thus turning **OFF** the magnetic clutch to prevent the evaporator from frosting.

**(Reference)**

- Thermostat setting temperature
  - OFF** ..... Approx. 1 °C (34 °F)
  - ON** ..... Approx. 4.5 °C (40.1 °F)

- |                           |                               |
|---------------------------|-------------------------------|
| (1) Micro Switch          | (6) Thermo Switch             |
| (2) Capillary Tube        | (7) Expansion Valve           |
| (3) Evaporator            |                               |
| (4) Heat Sensitizing Tube | <b>(a) To Magnetic Clutch</b> |
| (5) Diaphragm             | <b>(b) From A/C Switch</b>    |

12190M00390

**[5] WINDSHIELD WIPER**

**(1) Front Windshield Wiper**

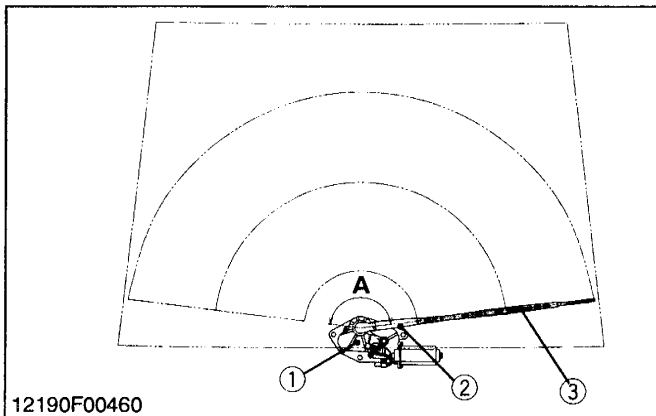

Front wiper motor is of the ferrite magnet type and possesses the function to stop the wiper arm at a designed position.

The wiper linkage changes rotating motion of the output shaft of the motor into reciprocating movement, which moves the wiper arm. The wiper arm uses a pantograph system, so the wiper blade keeps a certain angle (perpendicular) continuously although the wiper arm moves.

Wiping angle of the wiper arm is 2.90 rad. (166°). The wiper blade is for flat glass, and length of blade rubber is 400 mm (15.6 in.)

- |                       |                             |
|-----------------------|-----------------------------|
| (1) Front Wiper Motor | <b>(a) 2.90 rad. (166°)</b> |
| (2) Wiper Arm         |                             |
| (3) Wiper Blade       |                             |

12190M00400

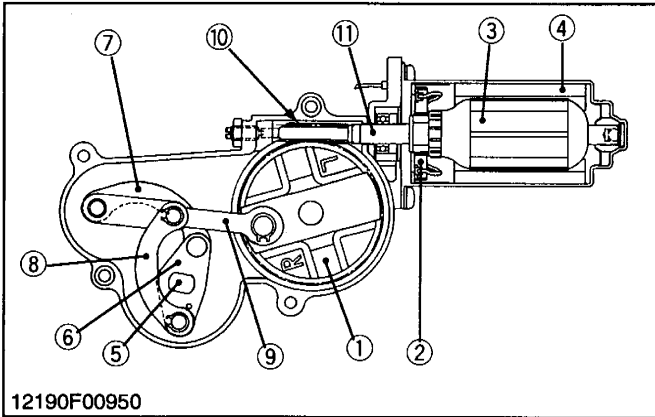
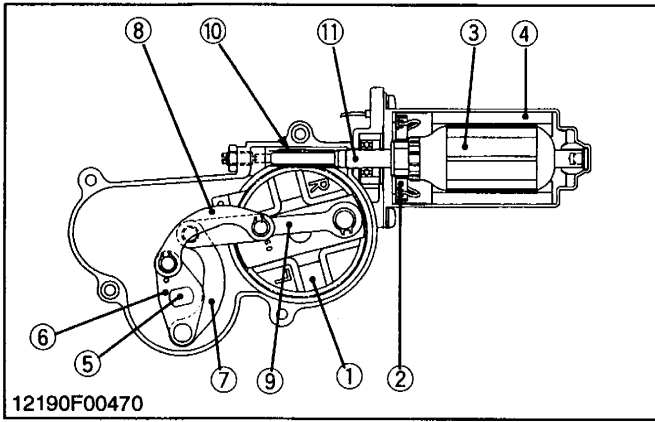

**Front Wiper Motor**

The front wiper motor is so designed as a field that cylindrical barium ferrite magnet (4) is fixed in the motor housing, in which armature (3) is mounted. Worm gear (10) is machined around armature shaft (11), and rotating speed of the armature is reduced by means of helical gear (1) and is transferred to motor shaft.

As the helical gear is turning, lever (6) which is attached to arm shaft (5) is oscillated by the function of rod (9) and crank A, B (7), (8).

- |                  |                     |
|------------------|---------------------|
| (1) Helical Gear | (7) Crank A         |
| (2) Brush        | (8) Crank B         |
| (3) Armature     | (9) Rod             |
| (4) Magnet       | (10) Worm Gear      |
| (5) Arm Shaft    | (11) Armature Shaft |
| (6) Lever        |                     |

12190M00410

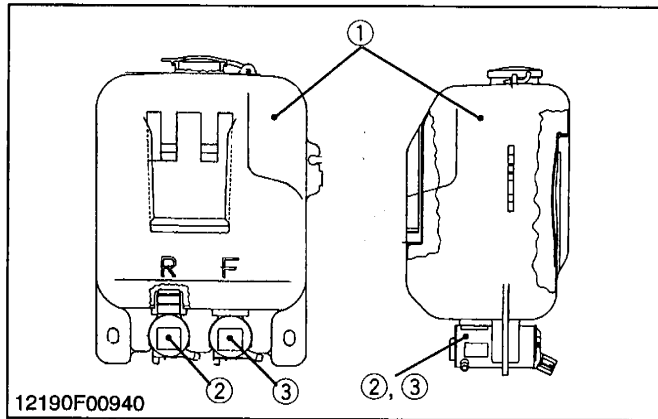
**(2) Window Washer**

The window washer is of the electric washer using a small size high speed motor and consists of tank, pump, nozzle, etc.

The washer tank is installed in right side of engine room and its capacity is 2.0 L (2.1 U.S.qts., 1.8 Imp.qts.).

Washer pump is mounted under the tank, and is driven by a motor. When the motor starts running, washer is drawn through the suction inlet and discharged through the discharge outlet to the washer nozzle.

(1) Tank  
(2) Pump (Rear)

(3) Pump (Front)

12190M00440



# SERVICING

## CONTENTS

<b>TROUBLESHOOTING-1</b> .....	10-S1
<b>TROUBLESHOOTING-2</b> .....	10-S3
<b>SERVICING SPECIFICATIONS</b> .....	10-S5
<b>TIGHTENING TORQUES</b> .....	10-S6
<b>PRECAUTIONS AT REPAIRING REFRIGERANT CYCLE</b> .....	10-S7
<b>HANDLING OF SERVICE TOOLS</b> .....	10-S8
(1) Manifold Gauge Set.....	10-S8
(2) Refrigerant Charging Hose.....	10-S9
(3) Vacuum Pump Adaptor .....	10-S10
(4) Electric Gas Leak Tester.....	10-S10
(5) Can Tap Valve.....	10-S10
(6) T-joint .....	10-S11
(7) R134a Refrigerant Recovery and Recycling Machine.....	10-S11
<b>CHECKING AND CHARGING REFRIGERANT CYCLE</b> .....	10-S11
<b>[1] CHECKING WITH MANIFOLD GAUGE</b> .....	10-S11
<b>[2] DISCHARGING, EVACUATING AND CHARGING</b> .....	10-S16
(1) Discharging the System .....	10-S16
(2) Evacuating the System.....	10-S16
(3) Charging the System.....	10-S18
(4) Checking Charge Refrigerant Amount .....	10-S20
<b>CHECKING, DISASSEMBLING AND SERVICING</b> .....	10-S20
<b>[1] SEPARATING CABIN FROM TRACTOR BODY</b> .....	10-S20
<b>DISASSEMBLING AND ASSEMBLING</b> .....	10-S20
<b>ADJUSTING</b> .....	10-S28
<b>[2] COMPRESSOR</b> .....	10-S28
<b>CHECKING</b> .....	10-S28
<b>DISASSEMBLING AND ASSEMBLING</b> .....	10-S29
<b>[3] AIR CONDITIONER SYSTEM AND FRONT WINDSHIELD WIPER</b> .....	10-S30
<b>CHECKING</b> .....	10-S30
(1) Air Conditioner Unit .....	10-S30
(2) Front Windshield Wiper.....	10-S35
<b>DISASSEMBLING AND ASSEMBLING</b> .....	10-S36
(1) Removing Air Conditioner Unit and Front Wiper Motor .....	10-S36
(2) Removing Air Conditioner Pipes .....	10-S39
(3) Removing Heater Hoses .....	10-S41
<b>SERVICING</b> .....	10-S43
(1) Air Conditioner Unit .....	10-S43
<b>[4] LIGHTING SYSTEM</b> .....	10-S43
<b>CHECKING</b> .....	10-S43
(1) Working Light .....	10-S43
(2) Hazard and Turn Signal Light.....	10-S44
<b>[5] OTHERS</b> .....	10-S45
<b>DISASSEMBLING AND ASSEMBLING</b> .....	10-S45
(1) Cab Windshields .....	10-S45



# TROUBLESHOOTING-1

## COMPRESSOR

Symptom	Probable Cause	Solution	Reference Page
<b>Noisy (Compressor ON)</b>	• Bearing of compressor worn or damaged	Replace	10-S30
	• Valves in compressor damaged	Replace	10-S30
	• Belt slipping	Adjust or replace	10-G2
	• Compressor bracket mounting screws loosen	Tighten	—
	• Piping resonant	Tighten or add clamp	—
<b>(Compressor OFF)</b>	• Blower defective	Repair or replace	10-S32
	• Bearings of magnetic clutch, idle pulley or crank pulley worn or damaged	Replace	10-S28

## AIR CONDITIONING SYSTEM

<b>Does Not Cool (No Air Flow)</b>	• Fuse blown	Replace	—
	• A/C relay defective	Repair or replace	10-S31
	• A/C blower motor defective	Replace	10-S32
	• A/C blower switch defective	Replace	10-S31
	• Wiring harness disconnected or improperly connected	Repair	—
<b>(Compressor Does Not Rotate)</b>	• Fuse blown	Replace	—
	• Magnetic clutch defective	Repair or replace	10-S28
	• A/C switch defective	Replace	10-S33
	• Pressure switch defective	Replace	10-S34
	• Belt slipping	Adjust or replace	10-G2
<b>(Others)</b>	• Insufficient refrigerant	Check with manifold gauge	10-S12
	• Expansion valve defective	Replace	—
	• Compressor defective	Replace	10-S30
<b>Insufficient Cooling (Insufficient Air Flow)</b>	• Air filter clogged	Clean or replace	10-G3
	• Evaporator frosted	Clean or replace thermo switch	10-S43
	• A/C blower motor defective	Replace	10-S32
	• A/C blower resistor defective	Replace	10-S32
<b>(Many Bubbles in Sight Glass)</b>	• Insufficient refrigerant	Check with manifold gauge	10-S12
	• Gas leaking from some place in refrigerating cycle	Repair and charge refrigerant	10-S10
	• Air mixed in	Check with manifold gauge	10-S13
<b>(No Bubbles in Sight Glass)</b>	• Too much refrigerant	Check with manifold gauge	10-S13

12190S00010

**AIR CONDITIONING SYSTEM (Continued)**

Symptom	Probable Cause	Solution	Reference Page
<b>Insufficient Cooling (Compressor Does Not Rotate Properly)</b>	<ul style="list-style-type: none"> <li>● Belt slipping</li> <li>● Magnetic clutch defective</li> <li>● Compressor defective</li> </ul>	Adjust or replace	10-G2
		Repair or replace	10-S28
<b>(Others)</b>	<ul style="list-style-type: none"> <li>● Thermostat defective</li> <li>● Water valve defective</li> <li>● Condenser fin clogged with dust</li> <li>● Expansion valve defective</li> </ul>	Replace	—
		Replace	—
		Clean	10-G2
		Replace	—
<b>Insufficient Heating</b>	<ul style="list-style-type: none"> <li>● Water valve defective</li> <li>● Air mix door malfunctioning</li> <li>● Insufficient cooling water</li> </ul>	Replace	—
		Adjust control cable	10-S27
		Replenish	10-S2
<b>Insufficient Cooling (Compressor Does Not Rotate Properly)</b>	<ul style="list-style-type: none"> <li>● Belt slipping</li> <li>● Magnetic clutch defective</li> <li>● Compressor defective</li> </ul>	Adjust or replace	10-S2
		Repair or replace	10-S28
<b>(Others)</b>	<ul style="list-style-type: none"> <li>● Condenser fin clogged with dust</li> <li>● Expansion valve defective</li> </ul>	Clean	10-G2
		Replace	—

**WINDSHIELD WIPER**

<b>Windshield Wiper Does Not Operate</b>	<ul style="list-style-type: none"> <li>● Wiring defective</li> <li>● Fuse blown (Short-circuit, burnt component inside motor or other part for operation)</li> <li>● Wiper motor defective (Broken armature, worn motor brush or seized motor shaft)</li> <li>● Wiper switch defective</li> <li>● Foreign material interrupts movement of link mechanism</li> <li>● Wiper arm seized or rusted</li> </ul>	Check and repair	10-S35
		Correct cause and replace	—
		Replace	10-S39
		Replace	10-S35
		Repair	—
<b>Windshield Wiper Operating Speed Is Too Low</b>	<ul style="list-style-type: none"> <li>● Wiper motor defective (Short-circuit of motor armature, worn motor brush or seized motor shaft)</li> <li>● Low battery voltage</li> <li>● Humming occurs on motor in arm operating cycle due to seized arm shaft</li> <li>● Wiper switch contact improper</li> </ul>	Replace	10-S39
		Recharge or replace	—
		Lubricate or replace	—
		Replace	10-S35
<b>Windshield Wiper Does Not Stop Correctly</b>	<ul style="list-style-type: none"> <li>● Wiper motor defective (Contaminated auto-return contacts or improper contact due to foreign matter)</li> </ul>	Replace	10-S39

12190S00020

# TROUBLESHOOTING-2

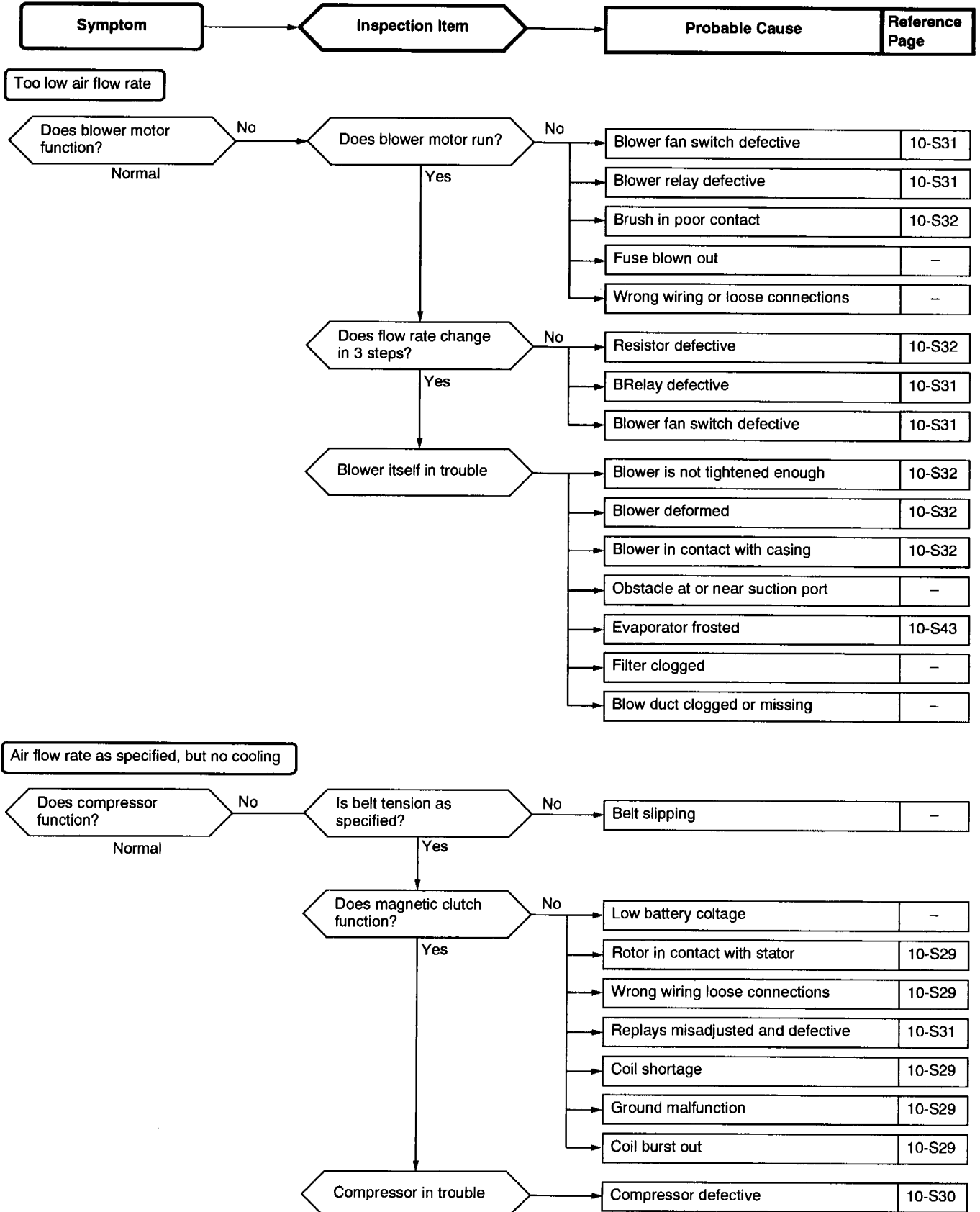

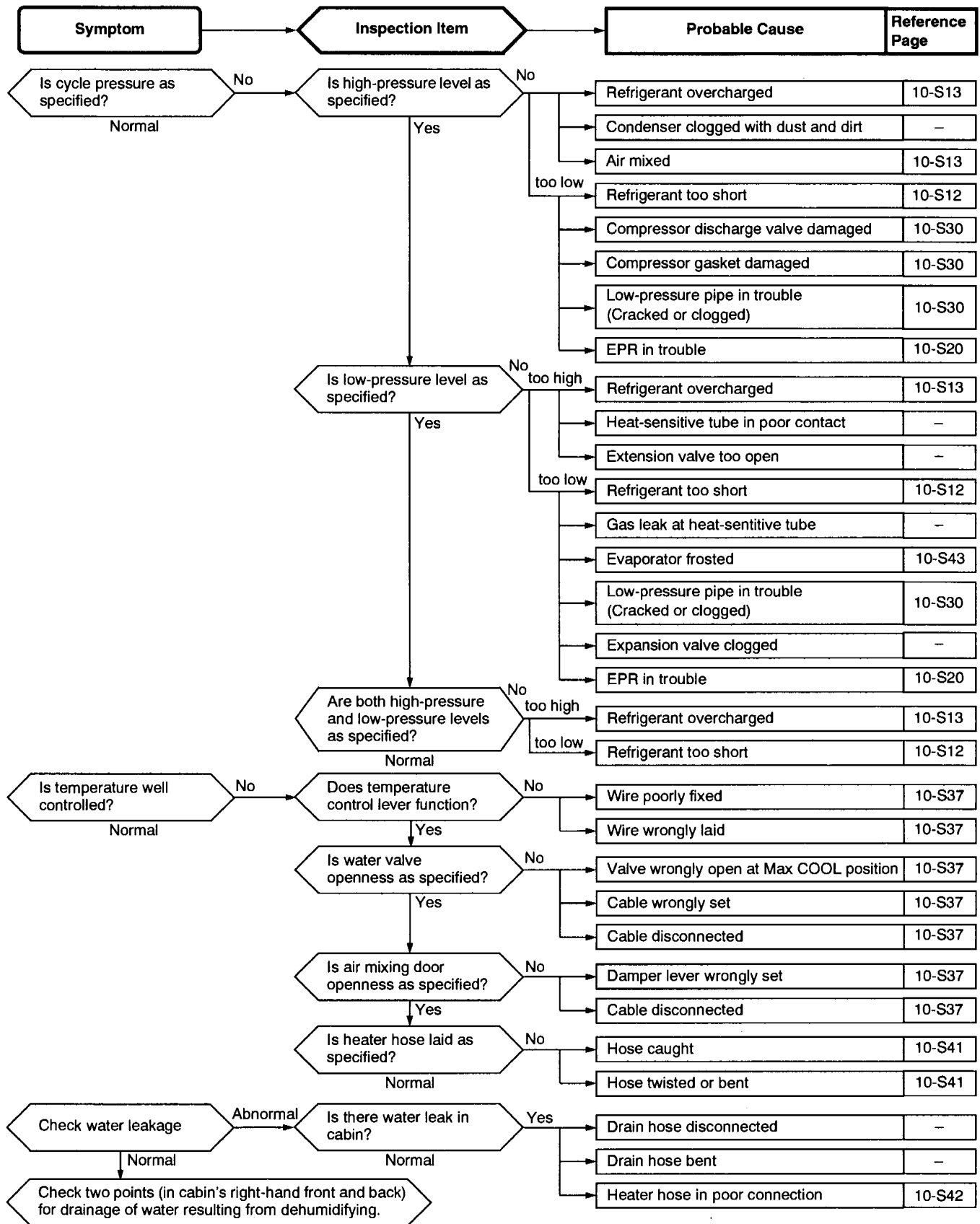

12190S00040

**WASHER MOTOR**

Symptom	Probable Cause	Solution	Reference Page
<b>Washer Motor Does Not Operate</b>	<ul style="list-style-type: none"> <li>● Fuse blown</li> <li>● Washer switch defective</li> <li>● Washer motor defective</li> <li>● Wiring defective</li> </ul>	Correct cause and replace Replace Replace Repair	– 10-S35 – 10-S35
<b>Washer Motor Operates but Washer Fluid Is Not Ejected</b>	<ul style="list-style-type: none"> <li>● No washer fluid</li> <li>● Clogged washer nozzle</li> </ul>	Replenish Clean or replace	– –

12190S00050

**SERVICING SPECIFICATIONS**

Item		Factory Specification	Allowable Limit
Refrigerating Cycle (Refrigerating Cycle is Notmal Operating) Condition <ul style="list-style-type: none"> <li>● Engine Speed : Approx. 1500 rpm</li> <li>● Embient Temperature : 30 to 35 °C 86 to 95 °F</li> <li>● Blower Switch : PURGE Position</li> </ul>	Pressure (LO Pressure Side)	0.15 to 0.20 MPa 1.5 to 2.0 kgf/cm <sup>2</sup> 21 to 28 psi	–
	Pressure (HI Pressure Side)	1.27 to 1.66 MPa 13 to 17 kgf/cm <sup>2</sup> 185 to 242 psi	–
Pressure Switch (Dual Type) (When pressure switch is turned <b>OFF</b> )	Setting Pressure (LO Pressure Side)	Less than approx. 0.196 MPa 2.0 kgf/cm <sup>2</sup> 28.4 psi	–
	Setting Pressure (HI Pressure Side)	More than approx. 3.4 MPa 32 kgf/cm <sup>2</sup> 455 psi	–
Air Conditioner Drive Belt	Tension	10 to 12 mm (0.39 to 0.47 in.) deflection at 98 N (10 kgf, 22 lbs) of force	–

12190S00060

## TIGHTENING TORQUES

Tightening torques of screws, bolts and nuts on the table below are especially specified.  
(For general use screws, bolts and nuts : See page G-9.)

Item	N·m	kgf·m	ft-lbs	
Cabin mounting screws and nuts	123.5 to 147	13 to 15	91 to 108	
Cabin bracket mounting screws				
M12 screw	77.5 to 90.2	7.9 to 9.2	57.2 to 66.5	
M14 screw	123.6 to 147.0	12.6 to 15.0	91.2 to 108.4	
Compressor mounting screws	24.5 to 29.4	2.5 to 3.0	18.1 to 21.7	
Compressor bracket mounting screws				
Screws to inlet manifold	23.6 to 27.4	2.4 to 2.8	17.4 to 20.2	
Screws to water flange	17.7 to 20.5	1.8 to 2.1	13.1 to 15.1	
High pressure pipe screw and retainer nut between compressor and condenser (High pressure pipe 1)				
screw	3.9 to 6.9	0.4 to 0.7	2.9 to 5.1	
retaining nut	19.7 to 24.5	2.0 to 2.5	14.5 to 18.0	
between condenser and receiver				
screw	3.9 to 6.9	0.4 to 0.7	2.9 to 5.1	
retaining nut	11.8 to 14.7	1.2 to 1.5	8.7 to 10.8	
between receiver and A/C unit (High pressure pipe 2)				
retaining nut	11.8 to 14.7	1.2 to 1.5	8.7 to 10.8	
Low pressure pipe				
between A/C unit and compressor				
screw	3.9 to 6.9	0.4 to 0.7	2.9 to 5.1	
retaining nut	29.5 to 34.3	3.0 to 3.5	21.7 to 25.3	
Wiper arm mounting nut	6.37 to 9.32	0.65 to 0.95	4.7 to 6.9	
Wiper motor mounting nut	2.5 to 3.4	0.25 to 0.35	1.9 to 2.5	
Main delivery hose retaining nut	46.6 to 50.9	4.8 to 5.2	34.4 to 37.6	
Turning delivery hose retaining nut	24.5 to 29.4	2.5 to 3.0	18.1 to 21.7	
GST shift cable mounting screws	7.8 to 8.8	0.8 to 0.9	5.8 to 6.5	
A/C unit mounting screw				
	(M6)	3.9 to 6.9	0.4 to 0.7	2.9 to 5.1
	(M8)	9.8 to 11.7	1.0 to 1.2	7.2 to 8.6

12190S00070



## PRECAUTIONS AT REPAIRING REFRIGERANT CYCLE

When checking or repairing the air conditioning system, the following precautions and rules must be observed. And it is of first importance that no other personnel than a well-trained serviceman should be allowed to handle the refrigerant.

### CAUTION

- Since direct contact of the liquid refrigerant with your skin will cause frostbite, always be careful when handling the refrigerant. Always wear goggles to protect your eyes when working around the system.
- The refrigerant service container has a safe strength. However, if handled incorrectly, it will explode. Therefore, always follow the instructions on the label. In particular, never heat the refrigerant container above 40 °C (104 °F) or drop it from a high height.
- Do not steam clean on the system, especially condenser since excessively high pressure will build up in the system, resulting in explosion of the system.
- If you improperly connect the hose between the service valve of compressor and gauge manifold, or incorrectly handle the valves, the refrigerant service container or charging hose will explode. When connecting the hose or handling the valve, be sure to check the high pressure side or low pressure side.
- In case the refrigerant is charged while the compressor is operated, do not open the high pressure valve of the gauge manifold.
- Beware of the toxicity of the gas. The gas is harmless and nontoxic in its original state, however it produces a toxic substance when it comes in contact with high temperature parts and decomposes.
- Do not heat the service can unless necessary. When it has to be heated, use warm water of 40 °C (104 °F) or lower. Do not heat using boiling water.

### ■ IMPORTANT

- If the refrigerant, O-rings, etc. for R12 are used in the R134a air conditioner system, problems such as refrigerant leakage or cloudiness in the sight glass may occur. Therefore, in order to prevent charging of refrigerant or erroneous connections, the shapes of the piping joint as well as the shapes of the service valve and the service tools have been changed.

### ■ IMPORTANT (Continued)

- Always keep the working place clean and dry and free from dirt and dust. Wipe off water from the line fittings with a clean cloth before disconnecting.
- Use only for R134a refrigerant service tool.
- Use for R134a refrigerant recovery and recycling machine when discharging the refrigerant.
- Before attaching the charging hose to the can tap valve of the refrigerant container, check each packing for clogging.
- When disconnecting the charging hose from the charging valve of compressor and receiver, remove it as quick as possible so that gas leakage can be minimized.
- Be sure to charge the specified amount of refrigerant, but not excessively. Over-charging of the refrigerant in particular may cause insufficient cooling, etc.
- Since the charging hose can be connected to can tap valve by hand, do not use a pliers for tightening it.
- Keep refrigerant containers in a cool and dark place avoiding such place which are subject to strong sunlight or high temperature.
- R134a compressor oil absorbs moisture easily, so that be sure to seal after disconnecting the each parts.
- Do not use old-type refrigerant R12a or compressor oil for old-type refrigerant.
- When replacing the condenser, evaporator and receiver, etc., replenish the compressor oil to compressor according to the table below.

Replacing Parts	Replenish Quantity	Brand Name
Condenser	40 cc 2.44 cu.in.	ND-OIL8 (PAG* OIL)
Evaporator	40 cc 2.44 cu.in.	
Circulation system (Total)	120 cm <sup>3</sup> 7.32 cu.in.	

\*Pag : Polyalkylenegly col (Synthetic oil)

12190S00080

# HANDLING OF SERVICE TOOLS

## (1) Manifold Gauge Set

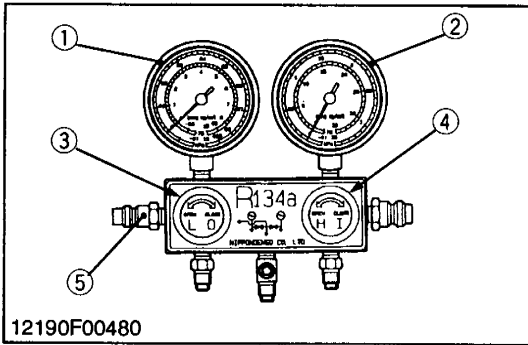

The hand valves on the manifold gauge set are used to open and close the valve. The hand valve inscribed **LO** is for the low pressure side valve (3) and **HI** is for the high pressure side valve (4). By opening or closing the high and low pressure hand valves, the following circuits are established.

- (1) LO Pressure Gauge
- (2) HI Pressure Gauge
- (3) LO Pressure Side Valve
- (4) HI Pressure Side Valve
- (5) Schrader Valve

12190S00090

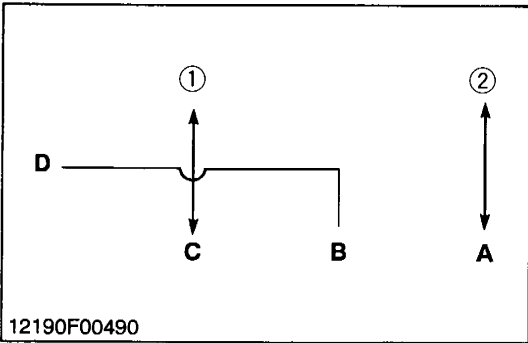

### ■ When LO Pressure Side Valve and HI Pressure Side Valve are Closed

Two circuits are established.

- Port (C) → LO pressure gauge (1)
- Port (A) → HI pressure gauge (2)

### ■ NOTE

- Schrader valve must be opened.

12190S00100

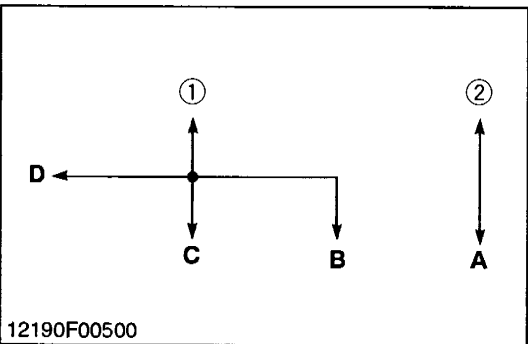

### ■ When LO Valve is Opened and HI Valve is Closed

Two circuits are established.

- Port (C) → LO pressure gauge (1)
- Port (C) → Port (B)
- Port (C) → Port (D)
- Port (A) → HI pressure gauge (2)

### ■ NOTE

- Schrader valve must be opened.

12190S00110

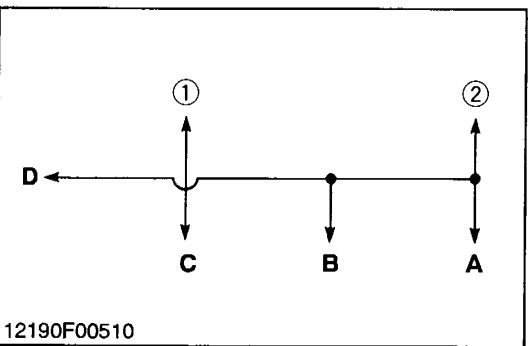

### ■ When LO Valve is Closed and HI Valve is Opened

Two circuits are established.

- Port (A) → HI pressure gauge (2)
- Port (A) → Port (B)
- Port (A) → Port (D) (Schrader valve must be opened)
- Port (C) → LO pressure gauge (1)

### ■ NOTE

- Schrader valve must be opened.

12190S00120

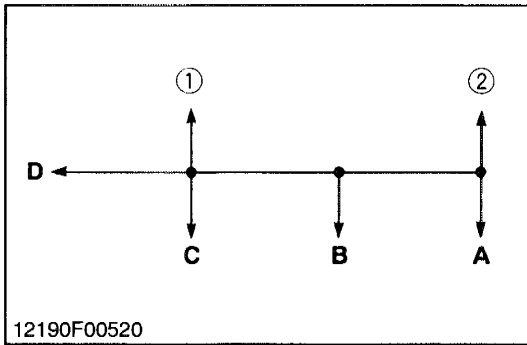

■ **When LO and HI Valves are Opened**

Circuits are established.

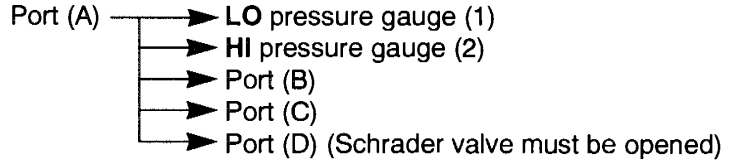

■ **NOTE**

- **Schrader valve must be opened.**

12190S00130

**(2) Refrigerant Charging Hose**

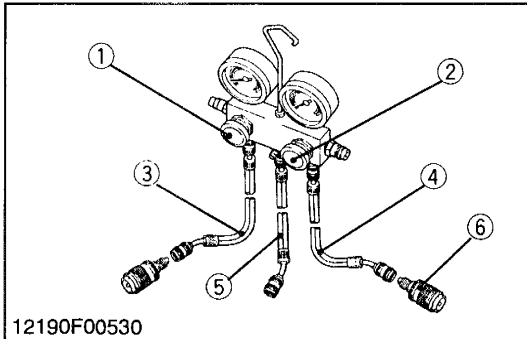

The charging hoses are classified into three colors. Each charging hose must be handled as follows :

- The air conditioner manufacture recommends that the blue hose (3) is used for the **LO** pressure side (suction side), the green hose (5) for refrigeration side (center connecting port) and the red hose (4) for **HI** pressure side (discharged side).

**(When connecting)**

- Push the quick disconnect adaptor (6) into the charging valve, and push on part A until a click is heard.

■ **NOTE**

- **When connecting, push carefully so the pipe doesn't bend.**
- **When connecting the quick disconnect connector, should the sleeve (7) move before the quick link connector can be connected to the charging valve, move the quick sleeve to its original position and try again.**
- **When some refrigerant remains in the charging hose at the time of connections, it may be difficult to connect the quick link connector. In this case, perform the operation after removing any residual pressure in the hose. (Remove the residual pressure by pushing the pusher (8).)**

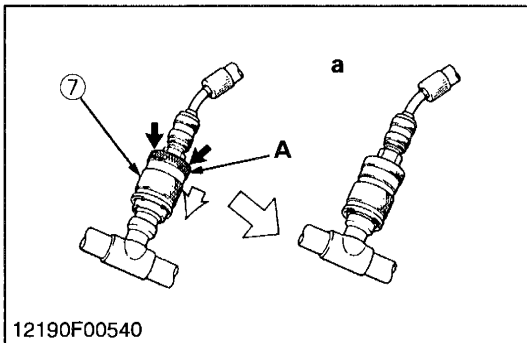

**(When reassembling)**

- While holding on to part A of the quick disconnect adaptor, slide part B up.

■ **NOTE**

- **After removing the adaptor, ensure to cap the quick disconnect adaptor service valve.**

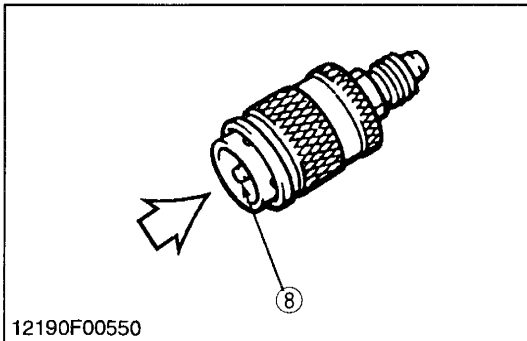

- |                              |                  |
|------------------------------|------------------|
| (1) LO Pressure Side Valve   | (7) Sleeve       |
| (2) HI Pressure Side Valve   | (8) Pusher       |
| (3) Blue Hose                | (9) Sleeve       |
| (4) Red Hose                 |                  |
| (5) Green Hose               | (a) <b>CLICK</b> |
| (6) Quick Disconnect Adaptor |                  |

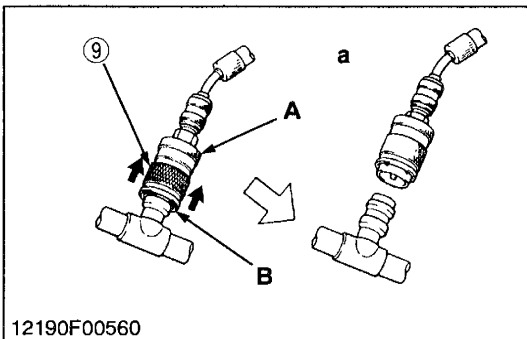

12190S00140

### (3) Vacuum Pump Adaptor

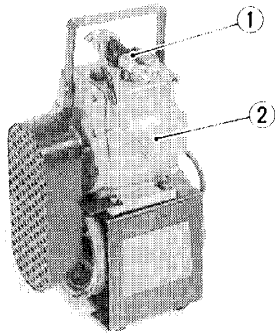

12190P00450

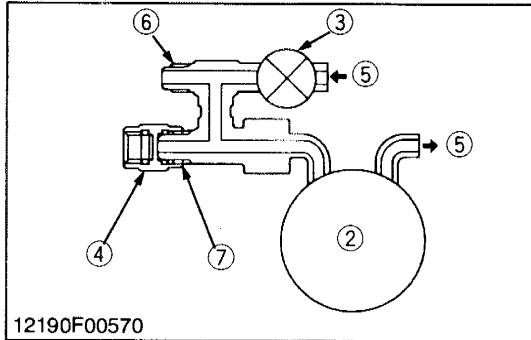

12190F00570

#### Objective of the Vacuum Pump Adaptor

1. After vacuum has been created in the air conditioning cycle, when the vacuum pump is stopped, since there is vacuum in hoses within the gauge manifold, the vacuum pump oil flows back into the charging hose. If the refrigerant is refilled with the system still in this state, the vacuum pump oil left in the charging hose enters the air conditioner cycle together with the refrigerant. Vacuum pump adaptor with a solenoid valve is used to prevent this back-flow of oil from the vacuum pump. The role of the solenoid valve is that when the current passes through the solenoid valve, the valve closes to keep out the outside air and allow the vacuum to build up, but when the current stops, the valve opens to allow in air and end the vacuum.
2. Attaching this adaptor to the R12 vacuum pump currently being used allows the pump to be used with both R134a and R12.

- |                         |               |
|-------------------------|---------------|
| (1) Vacuum Pump Adaptor | (6) For R134a |
| (2) Vacuum Pump         | (7) For R12   |
| (3) Magnetic Valve      |               |
| (4) Blind Cap           | (A) IN        |
| (5) Air                 | (B) OUT       |

12190S00150

### (4) Electric Gas Leak Tester

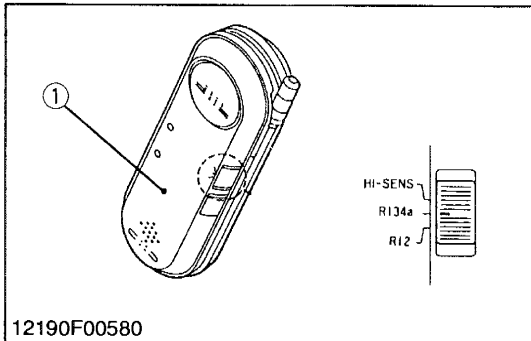

12190F00580

The current R12 gas leak tester has poor sensitivity for R134a and cannot be used. Therefore, a new electric gas leak tester with greater sensitivity has been designed and can be used with both R134a and R12.

#### (Reference)

Leak tester with halide torch

- Since the reaction with chlorine within the refrigerant is used to detect gas leaks, R134a, which contains no chlorine, cannot be detected.

- (1) Electric Gas Leak Tester

12190S00160

### (5) Can Tap Valve

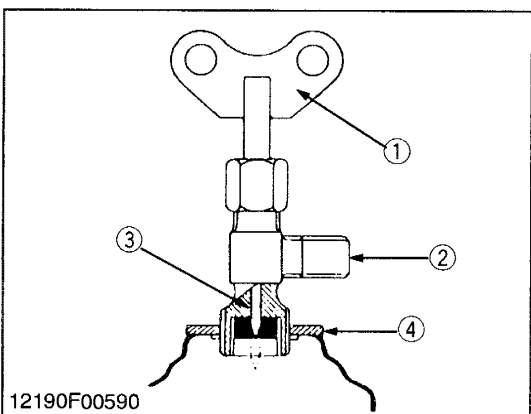

12190F00590

The can tap valve that is used to charge the refrigerant into the air conditioning system, should be used as follows :

1. Before putting the can tap valve on the refrigerant container, turn the handle (1) counterclockwise till the valve needle is fully retracted.
2. Turn the plate nut (disc) (4) counterclockwise till it reaches its highest position, then screw down the can tap valve into the sealed tap.
3. Turn the plate nut clockwise fully, and fix the center charging hose to the valve.
4. Tighten the plate nut firmly by hand.
5. Turn the handle (1) clockwise, thus making a hole in the sealed tap.
6. To charge the refrigerant into the system, turn the handle (1) counterclockwise. To stop charging, turn it clockwise.

- |                      |            |
|----------------------|------------|
| (1) Butterfly Handle | (3) Needle |
| (2) Connection       | (4) Disc   |

12190S00170

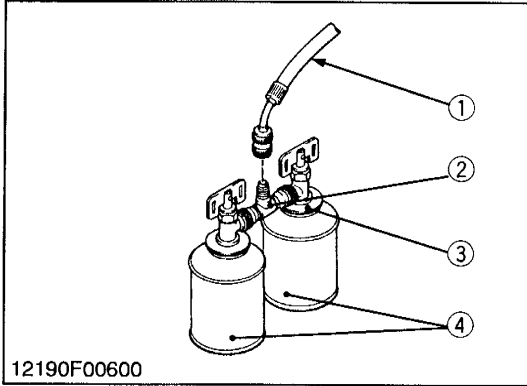
**(6) T-joint**

T-joint (2) is used to increase efficiency of gas charging using two refrigerant containers (4) at a time.

1. Install two refrigerant container service valves to T-joint (2) sides and connect the charging hose (1) to it.

- |                           |                           |
|---------------------------|---------------------------|
| (1) Charging Hose (Green) | (3) Can Tap Valve         |
| (2) T-joint               | (4) Refrigerant Container |

12190S00180

**(7) R134a Refrigerant Recovery and Recycling Machine**

When there is necessity of discharging the refrigerant on repairing the tractor, it should use recovery and recycling machine. (Don't release the refrigerant into the atmosphere.)

**■ IMPORTANT**

- Use only R134a refrigerant recovery and recycling machine, eliminate mixing R134a equipment, refrigerant and refrigerant oils with R12 systems to prevent compressor damage.

12190S00190

**CHECKING AND CHARGING REFRIGERANT CYCLE****[1] CHECKING WITH MANIFOLD GAUGE****■ IMPORTANT**

- The gauge indications described in the following testing are those taken under the same condition, so it should be noted that the gauge readings will differs somewhat with the ambient conditions.

**Condition**

- Ambient temperature : 30 to 35 °C (86 to 95 °F)
- Engine speed : Approx. 1500 rpm
- Temperature control lever : **Maximum cooling position**
- Blower switch : **HI** position

12190S00200

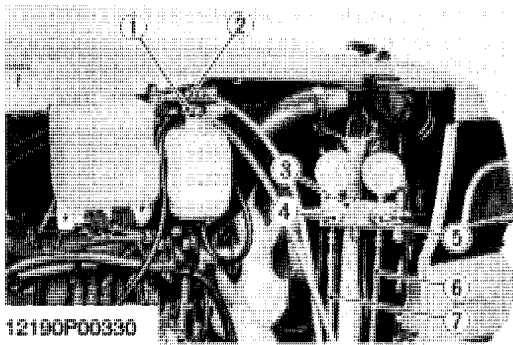

12190P00330

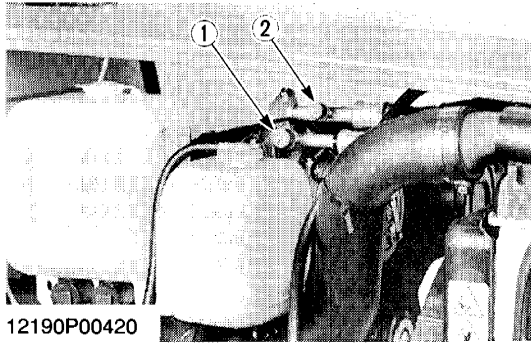

12190P00420

**Manifold Gauge Connecting and Test Preparation**

1. Close the manifold gauge HI and LO pressure side valve (5), (4) tightly.
2. Connect the charging hose (6) (red) to the HI pressure side charging valve (1) and connect the charging hose (7) (blue) to the LO pressure side charging valve (2).

**NOTE**

- **Be sure to drive out the air in the charging hoses at the manifold gauge connection end by utilizing the refrigerant pressure in the refrigerating cycle.**
3. Start the engine and set at approx. **1500 rpm**.
  4. Turn on the A/C switch and set the temperature control lever to **maximum cooling** position.
  5. Set the blower switch to **HI** position.

- |                                     |                            |
|-------------------------------------|----------------------------|
| (1) HI Pressure Side Charging Valve | (5) HI Pressure Side Valve |
| (2) LO Pressure Side Charging Valve | (6) Charging Hose (Red)    |
| (3) Manifold Gauge                  | (7) Charging Hose (Blue)   |
| (4) LO Pressure Side Valve          |                            |

12190S00210

**Normal Operating**

If the refrigerating cycle is operating normally, the reading at the **LO** pressure side (1) should be generally by around 0.15 to 0.2 MPa (1.5 to 2.0 kgf/cm<sup>2</sup>, 21 to 28 psi) and that at the **HI** pressure side (2) around 1.27 to 1.66 MPa (13 to 17 kgf/cm<sup>2</sup>, 185 to 242 psi).

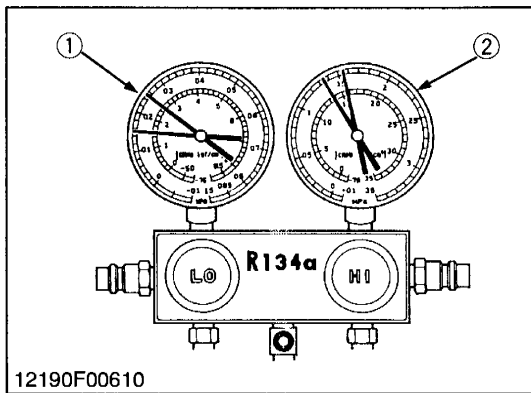

12190F00610

Gas pressure	Factory spec.	Low pressure side	0.15 to 0.20 MPa 1.5 to 2.0 kgf/cm <sup>2</sup> 21 to 28 psi
		High pressure side	1.27 to 1.66 MPa 13 to 17 kgf/cm <sup>2</sup> 185 to 242 psi

(1) LO Pressure Side

(2) HI Pressure Side

12190S00220

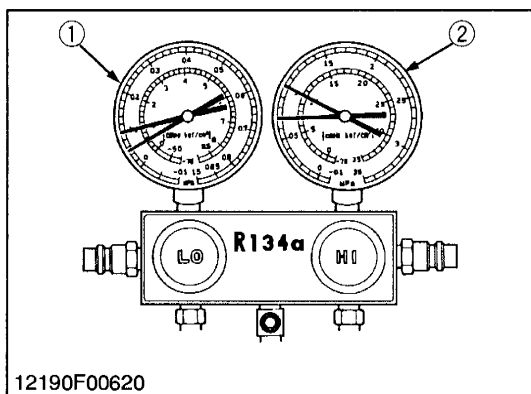

12190F00620

**Insufficient Refrigerant**

- a) Symptoms seen in refrigerating cycle
  - Both **LO** and **HI** pressure side (1), (2) pressures too low.
    - LO** pressure side (1) : 0.05 to 0.1 MPa  
(0.5 to 1.0 kgf/cm<sup>2</sup>, 7.1 to 14.2 psi)
    - HI** pressure side (2) : 0.69 to 0.98 kPa  
(7 to 10 kgf/cm<sup>2</sup>, 99.6 to 142.2 psi)
  - Bubbles seen in sight glass.
  - Air discharged from air conditioner slightly cold.
- b) Probable cause
  - Gas leaking from some place in refrigerant cycle.
- c) Solution
  - Check for leakage with electric gas leak tester (see page 10-S10) and repair.
  - Recharge refrigerant to the proper level. (See page 10-S18)

(1) LO Pressure Side

(2) HI Pressure Side

12190S00230

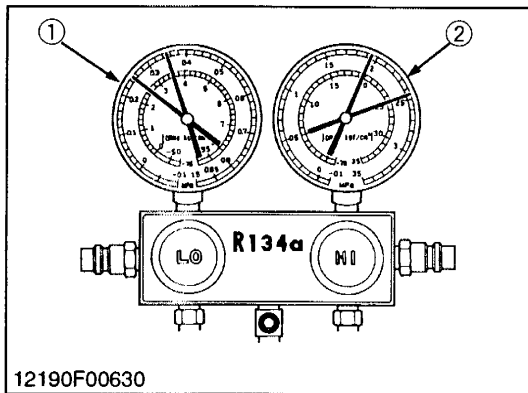

### **Excessive Refrigerant or Insufficient Condenser Cooling**

#### a) Symptoms seen in refrigerating cycle

- Both **LO** and **HI** pressure side (1), (2) pressures too high.
  - LO** pressure side (1) : 0.2 to 0.35 MPa  
(2.0 to 3.5 kgf/cm<sup>2</sup>, 28 to 49.8 psi)
  - HI** pressure side (2) : 1.96 to 2.45 MPa  
(20 to 25 kgf/cm<sup>2</sup>, 284.5 to 355.6 psi)

#### b) Probable cause

- Overcharging refrigerant into cycle.
- Condenser cooling faulty.

#### c) Solution

- Clean condenser. (See page 10-G2.)
- Adjust fan belt to proper tension. (See page G-18.)
- If the above two items are in normal condition, check refrigerant quantity. (See page 10-S20.)

### ■ NOTE

- **If excessive refrigerant is to be discharged, loosen manifold gauge LO pressure side valve and vent out slowly.**

(1) LO Pressure Side

(2) HI Pressure Side

12190S00240

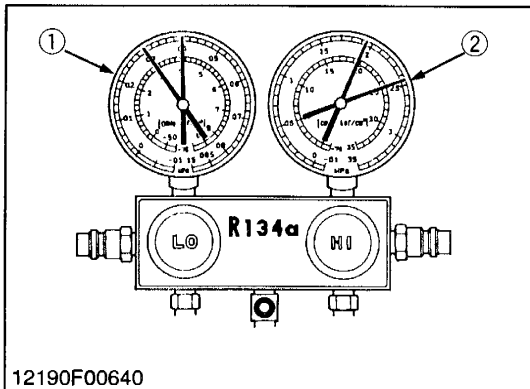

### **Air Entered in the Cycle**

#### a) Symptoms seen in refrigerating cycle

- Both **LO** and **HI** pressure side (1), (2) pressures too high.
  - LO** pressure side (1) : 0.2 to 0.35 MPa  
(2.0 to 3.5 kgf/cm<sup>2</sup>, 28 to 49.8 psi)
  - HI** pressure side (2) : 1.96 to 2.45 MPa  
(20 to 25 kgf/cm<sup>2</sup>, 284.5 to 355.6 psi)
- **LO** pressure side (1) piping not cold when touched.

#### b) Probable cause

- Air entered in refrigerating cycle.

#### c) Solution

- Replace receiver.
- Check compressor oil contamination and quantity.
- Evacuate and recharge new refrigerant. (See page 10-S17, 18.)

### ■ NOTE

- **The above cycle can be seen when the cycle is charged without evacuation.**

(1) LO Pressure Side

(2) HI Pressure Side

12190S00250

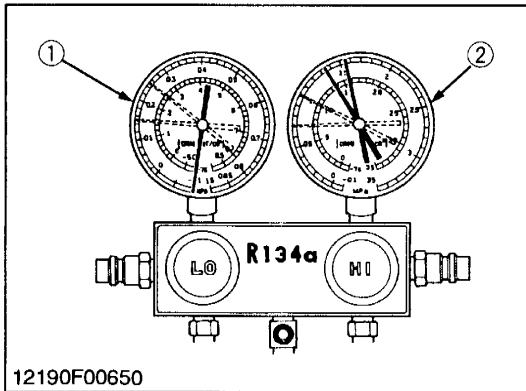

### Moisture Entered in the Cycle

#### a) Symptoms seen in refrigerating cycle

- The air conditioner operates normally at the beginning, but over time, **LO** pressure side (1) pressure is **vacuum** and **HI** pressure side (2) is **low** pressure.

**LO** pressure side (1) : Vacuum

**HI** pressure side (2) : 0.69 to 0.98 MPa  
(7 to 10 kgf/cm<sup>2</sup>, 99.6 to 142.2 psi)

#### b) Probable cause

- The moisture in the refrigerating cycle freezes in the expansion valve orifice and causes temporary blocking. After a time, the ice melts and condition returns to normal.

#### c) Solution

- Replace receiver.
- Remove moisture in cycle by means of repeated evacuation. (See page 10-S17.)
- Recharge new refrigerant to the proper level. (See page 10-S18.)

(1) **LO** Pressure Side

(2) **HI** Pressure Side

12190S00260

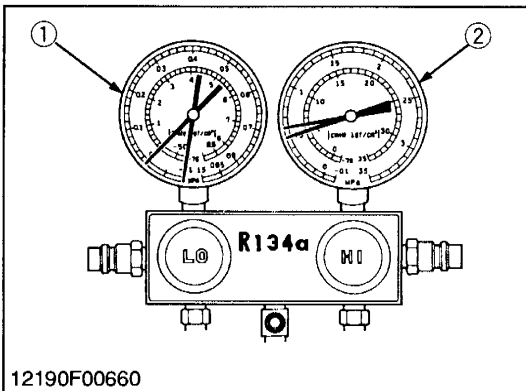

### Refrigerant Fails to Circulate

#### a) Symptoms seen in refrigerating cycle

- **LO** pressure side (1) pressure is **vacuum** and, **HI** pressure side (2) is **low** pressure.

**LO** pressure side (1) : Vacuum

**HI** pressure side (2) : 0.49 to 0.59 MPa  
(5 to 6 kgf/cm<sup>2</sup>, 21.1 to 85.3 psi)

- Frost or dew formed on piping at front and rear sides of expansion valve or receiver.

#### b) Probable cause

- Refrigerant flow obstructed by moisture or dirt in the refrigerating cycle freezing or sticking on the expansion valve orifice.

#### c) Solution

Allow to stand for some time and then resume operation to decide whether the plugging is due to moisture or dirt.

- If caused by moisture, correct by referring to instructions in previous.
- If caused by dirt, remove the expansion valve and blow out the dirt with compressed air.
- If unable to remove the dirt, replace the expansion valve. Replace the receiver. Evacuate and charge in proper amount of new refrigerant. (See page 10-S17, 18, 19.)
- If caused by gas leakage in heat sensitizing tube, replace the expansion valve.

(1) **LO** Pressure Side

(2) **HI** Pressure Side

12190S00270



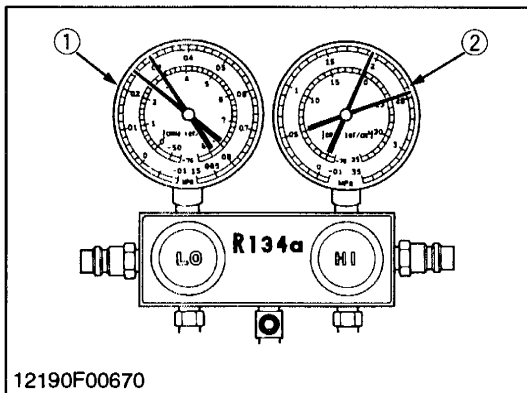

### Expansion Valve Opens Too Far or Improper Installation of Heat Sensitizing Tube

#### a) Symptoms seen in refrigerating cycle

- Both LO and HI pressure side (1), (2) pressures too high.  
 LO pressure side (1) : 0.29 to 0.39 MPa  
 (3.0 to 4.0 kgf/cm<sup>2</sup>, 42.7 to 56.9 psi)  
 HI pressure side (2) : 1.96 to 2.45 MPa  
 (20 to 25 kgf/cm<sup>2</sup>, 284.5 to 355.6 psi)

- Frost or heavy dew on low pressure side piping.

#### b) Probable cause

- Expansion valve trouble or heat sensitizing tube improperly installed.
- Flow adjustment not properly done.

#### c) Solution

- Check installed condition of heat sensitizing tube.
- If installation of heat sensitizing tube is correct, replace the expansion valve.

(1) LO Pressure Side

(2) HI Pressure Side

12190S00280

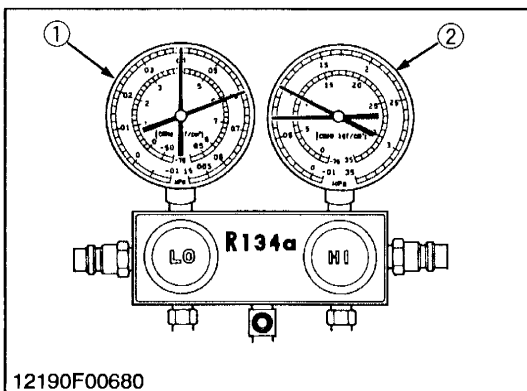

### Faulty Compression of Compressor

#### a) Symptoms seen in refrigerating cycle

- LO pressure side (1) pressure too high :0.39 to 0.59 MPa (4 to 6 kgf/cm<sup>2</sup>, 56.9 to 85.3 psi) .
- HI pressure side (2) pressure too low :0.69 to 0.98 MPa (7 to 10 kgf/cm<sup>2</sup>, 99.6 to 142.2 psi) .

#### b) Probable cause

- Leak in compressor

#### c) Solution

- Replace compressor. (See page 10-S30.)

#### ■ NOTE

- Manifold gauge indications (left side figure) at faulty compressing by compressor.

(1) LO Pressure Side

(2) HI Pressure Side

12190S00290

## [2] DISCHARGING, EVACUATING AND CHARGING

### ■ IMPORTANT

- When discharging, evacuating or charging the refrigerating system, be sure to observe the "PRECAUTION AT REPAIRING REFRIGERANT CYCLE". (See page 10-S7.)

12190S00300

### (1) Discharging the System

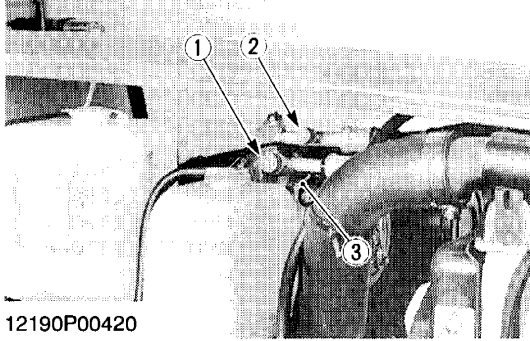

12190P00420

Prepare for the R134a refrigerant recovery and recycling machine.

1. Connect low pressure side hose (blue) from the recovery and recycling machine to LO pressure side charging valve (2) on the compressor (3). Connect high pressure side hose (red) to HI pressure side charging valve (1) on the compressor (3).
2. Follow the manufacturers instructions and discharge the system.

### ■ IMPORTANT

- Use only R134a refrigerant recovery and recycling machine. Eliminate mixing R134a equipment, refrigerant, and refrigerant oils with R12 systems to prevent compressor damage.

### ⚠ CAUTION

- Protect fingers with cloth against frostbite by refrigerant when disconnecting the hose to the charging valve.

- (1) HI Pressure Side Charging Valve      (3) Compressor  
 (2) LO Pressure Side Charging Valve

12190S00310

### (2) Evacuating the System

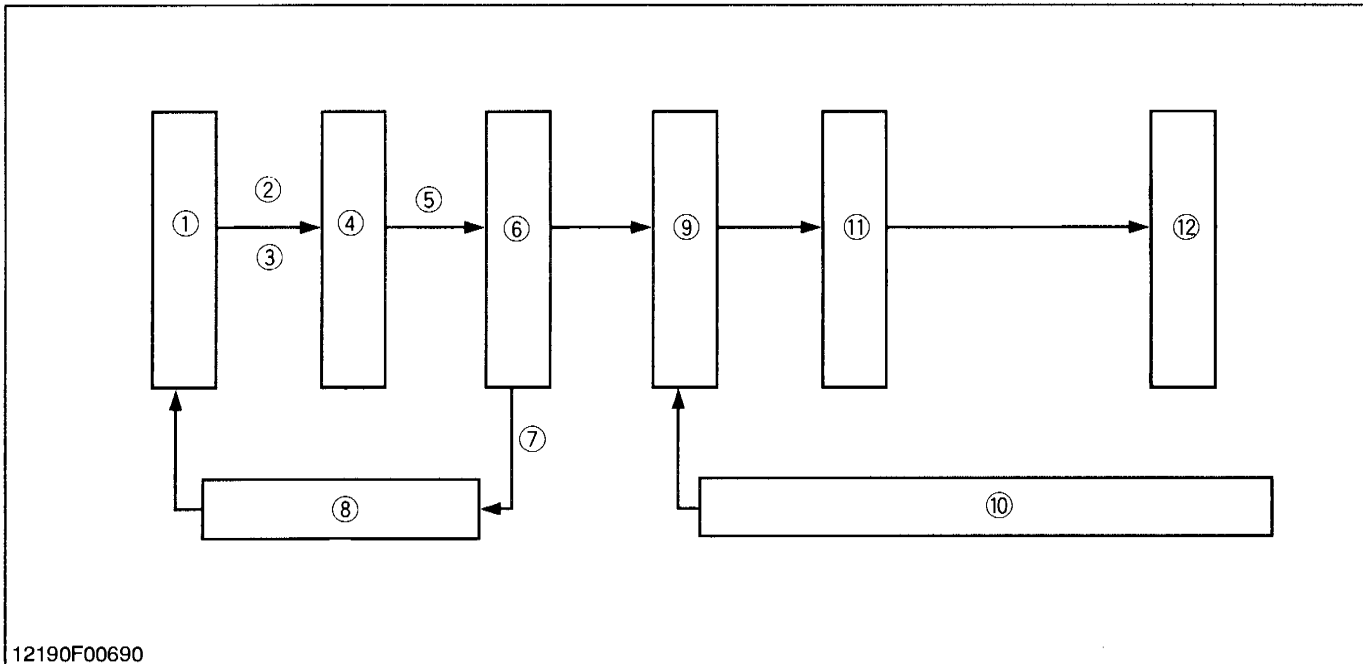

12190F00690

- |                           |                               |   |   |
|---------------------------|-------------------------------|---|---|
| (1) Begin Creating Vacuum | (5) Leave for 5 minutes       | (8) Checking Connecting Parts, and Correction | (10) Filling Refrigerant (98 kPa, 1 kgf/cm <sup>2</sup> , 14 psi) |
| (2) Approx. 15 minutes    | (6) Checking Airtightness     | (9) Charging Refrigerant                      | (11) Gas Leak Testing   |
| (3) 750 mm Hg or more     | (7) Gauge Indication Abnormal |   | (12) Charging Refrigerant   |
| (4) Stop Creating Vacuum  |                               |   |   |

12190S00320

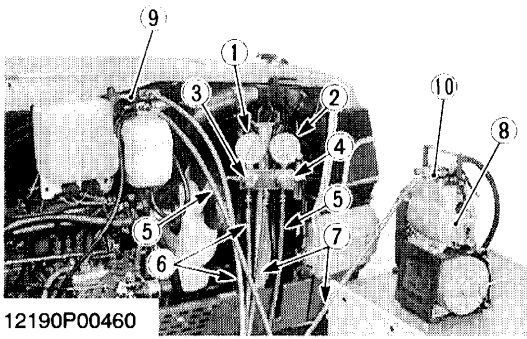

12190P00460

### Evacuating the System

1. Discharge refrigerant from the system by R134a refrigerant recovery and recycling machine. (Refer to “Discharging the system”.)
2. Connect the charging hose (5) (red) to the **HI** pressure side charging valve and connect the charging hose (6) (blue) to the **LO** pressure side charging valve.
3. Connect the center charging hose (7) (green) to a vacuum pump inlet.
4. Open both valves (3), (4) of manifold gauge fully. Then run the vacuum pump (8) to evacuate the refrigerant cycle. (For approx. **15 minutes.**)
5. When **LO** pressure gauge (1) reading is more than **750mmHg (299 in.Hg)**, stop the vacuum pump (8) and close both valves (3), (4) of manifold gauge fully.
6. Wait for over **5 minutes** with the **HI** and **LO** pressure side valves (4), (3) of gauge manifold closed, and then check that gauge indicator does not return to **0**.
7. If the gauge indicator is going to approach to **0**, check whether there is a leaking point and repair if it is, and then evacuate it again.

- |   |                           |
|---|---------------------------|
| (1) <b>LO</b> Pressure Gauge              | (6) Blue Hose             |
| (2) <b>HI</b> Pressure Gauge              | (7) Green Hose            |
| (3) <b>LO</b> Pressure Side Valve (Close) | (8) Vacuum Pump (Running) |
| (4) <b>HI</b> Pressure Side Valve (Open)  | (9) Compressor            |
| (5) Red Hose                              | (10) Vacuum Pump Adaptor  |

12190S00330

### (3) Charging the System

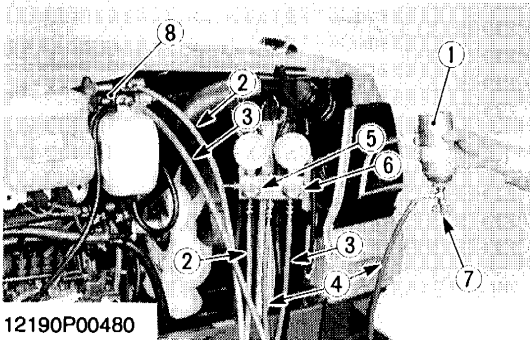
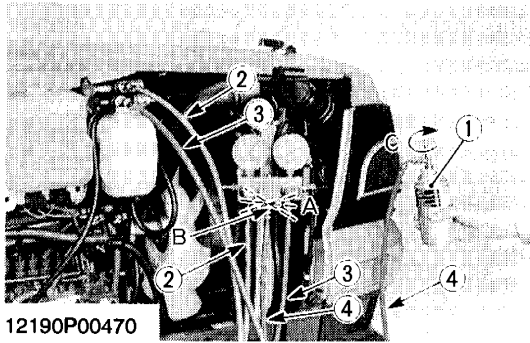

#### Charging an Empty System (Liquid)

This procedure is for charging an empty system through the **HI** pressure side with the refrigerant in the liquid state.

#### ⚠ CAUTION

- Never run the engine when charging the system through the **HI** pressure side.
- Do not open the **LO** pressure valve when refrigerant R134a is being charged in the liquid state (refrigerant container is placed upside-down).

#### ■ IMPORTANT

- After charging the refrigerant in the liquid state with approx. 500 g (1.1 lbs) through the **HI** pressure side, be sure to recharge the refrigerant in the vapor state to specified amount through the **LO** pressure side.

1. Close the **HI** and **LO** pressure side valves (6), (5) of manifold gauge after the system is evacuated completely.
2. Connect the center charging hose (4) to the can tap valve (7) fitting, and then loosen the center charging hose at the center fitting of manifold gauge until hiss can be heard.

Allow the air to escape for few seconds and tighten the nut.

3. Open the **HI** pressure side valve (6) fully, and keep the container upside-down to charge the refrigerant in the liquid state from the **HI** pressure side.
4. Charge the refrigerant in the liquid state with approx. 500 g (1.1 lbs) from the **HI** pressure side.

#### ■ NOTE

- If **LO** pressure gauge does not show a reading, the system is clogged and must be repaired.
5. Close the **HI** pressure side valve (6) of manifold gauge and can tap valve of refrigerant container.

- |   |                            |
|---|----------------------------|
| (1) Refrigerant Container (R134a)         | (7) Can Tap Valve (Open)   |
| (2) Blue Hose                             | (8) Compressor             |
| (3) Red Hose                              |                            |
| (4) Green Hose                            | (A) Air Purge              |
| (5) <b>LO</b> Pressure Side Valve (Close) | (B) Loosen the Nut         |
| (6) <b>HI</b> Pressure Side Valve (Open)  | (C) Open the Can Tap Valve |

12190S00340

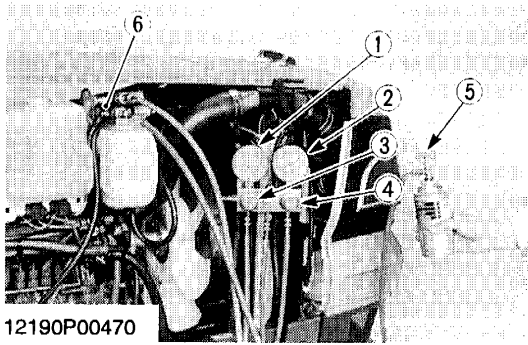

12190P00470

### **Charging an Empty or Partially Charged System (Vapor)**

This procedure is to charge the system through the **LO** pressure side with refrigerant in the vapor state. When the refrigerant container is placed right side up, refrigerant will enter the system as a vapor.

#### **⚠ CAUTION**

- **Never open the HI pressure valve of manifold gauge while the engine is running.**

#### **■ NOTE**

- **Do not turn the refrigerant container upside-down when charging the system by running the engine.**
- **Put refrigerant container into a pan of warm water (maximum temperature 40 °C (104 °F)) to keep the vapor pressure in the container slightly higher than vapor pressure in the system.**

1. Check that the **HI** pressure valve (4) is closed.
2. Start the engine and set an approx. 1500 rpm.
3. Turn on the A/C switch.  
Set the temperature control lever to maximum cooling position and the blower switch to **HI** position.
4. Open the **LO** pressure valve (3) of manifold gauge and the can tap valve (5) on refrigerant container and charge the refrigerant until air bubbles in the sight glass of the receiver vanish.
5. After charging the specified amount of refrigerant into the system, close the **LO** pressure valve (3) of manifold gauge and can tap valve (5), then stop the engine.
6. Check for gas leak with a electric gas leak tester (see page 10-S10).

#### **(Reference)**

- Specified amount of refrigerant (total) :
- 900 to 1000 g (2.0 to 2.2 lbs) [Refrigerant R134a]
- Manifold gauge indication at fully charged system (at ambient temperature : 30 °C (86 °F))

<b>HI</b> pressure side :	1.27 to 1.66 MPa 13 to 17 kgf/cm <sup>2</sup> 185 to 242 psi
<b>LO</b> pressure side :	0.15 to 0.20 MPa 1.5 to 2.0 kgf/cm <sup>2</sup> 21 to 28 psi

- |                                     |                                      |
|-------------------------------------|--------------------------------------|
| (1) <b>LO</b> Pressure Gauge        | (4) <b>HI</b> Pressure Valve (Close) |
| (2) <b>HI</b> Pressure Gauge        | (5) Can Tap Valve                    |
| (3) <b>LO</b> Pressure Valve (Open) | (6) Compressor (Running)             |

12190S00350

## (4) Checking Charge Refrigerant Amount

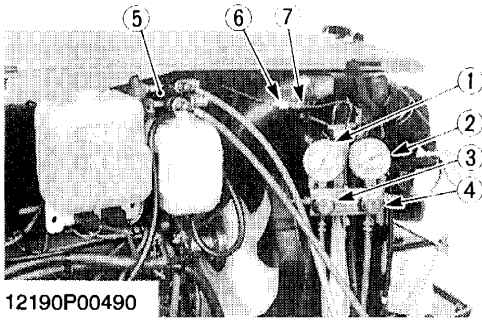

12190P00490

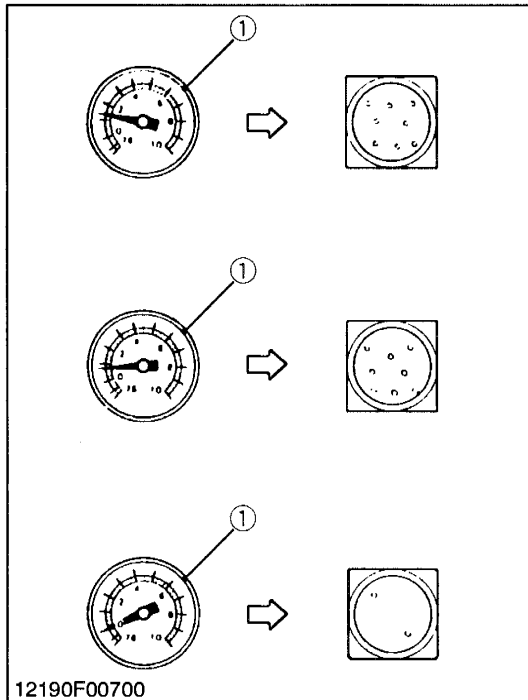

12190F00700

After charging the refrigerant, check for amount of charging refrigerant as follows.

### ■ NOTE

- The pressure on the following checking are the gauge indications at ambient temperature 30 °C (86 °F), so it should be noted that the pressure will differ some what with the ambient temperature.

1. Disconnect the **1P** connector (6) of magnetic clutch.
2. Start the engine and set at approx. **1500 rpm**.
3. Connect the **1P** connector (6) of magnetic clutch to battery directly, and then set the blower switch to **HI** position.
4. Leave the system for approx. **5 minutes** until the refrigerant cycle becomes stable, keeping pressure on the **HI** pressure side from 1.27 to 1.66 MPa (13 to 17 kgf/cm<sup>2</sup>, 185 to 242 psi).
5. When the refrigerant cycle is stabilizer, turn off the blower switch and let the compressor alone to run. Then pressure on the **LO** pressure side gradually drops. At this time, if pressure on the **HI** pressure side is maintained from 1.27 to 1.66 MPa (13 to 17 kgf/cm<sup>2</sup>, 185 to 242 psi), air bubbles which pass through the sight glass become as stated below depending on refrigerant charged amount.

### A: Insufficient refrigerant charge

Air bubbles pass continuously the sight glass when pressure on the **LO** pressure side is over 99.0 kPa (1.01 kgf/cm<sup>2</sup>, 14.4 psi). In this case, charge the refrigerant from the **LO** pressure side.

### B: Properly refrigerant charge

Air bubbles pass through the sight glass continuously when pressure on the **LO** pressure side is within 59 to 98 kPa (0.6 to 1.0 kgf/cm<sup>2</sup>, 9 to 14 psi).

If the charge refrigerant amount is proper, no air bubble is observed on the sight glass at pressure on the **LO** pressure side over 99.0 kPa (1.01 kgf/cm<sup>2</sup>, 14.4 psi) when the blower switch is turned on. When the blower switch is turned off, bubbles pass through the sight glass in case pressure on the **LO** pressure side is within 59 to 98 kPa (0.6 to 1.0 kgf/cm<sup>2</sup>, 9 to 14 psi).

### C: Excessive refrigerant charge

Air bubbles pass through the sight glass time to time or no air bubble is observed when pressure on the **LO** pressure side is under 59 kPa (0.6 kgf/cm<sup>2</sup>, 9 psi).

In this case, discharge excessive refrigerant gradually from the **LO** pressure side.

- |                               |                          |
|-------------------------------|--------------------------|
| (1) LO Pressure Gauge         | (5) Compressor (Running) |
| (2) HI Pressure Gauge         | (6) 1P Connector         |
| (3) LO Pressure Valve (Close) | (7) To Battery           |
| (4) HI Pressure Valve (Close) |                          |

12190S00360

# CHECKING, DISASSEMBLING AND SERVICING

## [1] SEPARATING CABIN FROM TRACTOR BODY

### DISASSEMBLING AND ASSEMBLING

The disassembling method described here is a procedure for disassembly that doesn't require discharging air conditioner refrigerant from the air conditioner system.

12190S00370

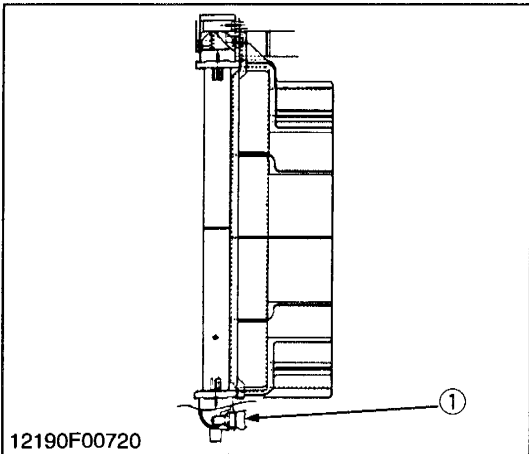
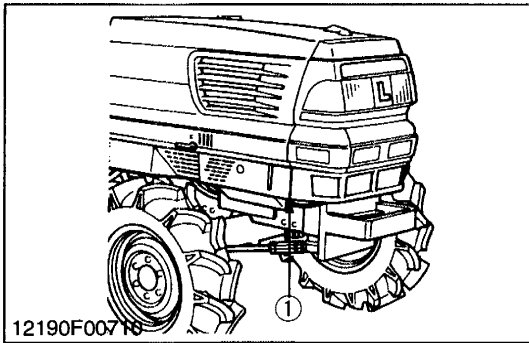

**Draining Coolant**

**⚠ CAUTION**

- **Never remove the radiator cap until coolant temperature is well below its boiling point. Then loosen cap slightly to relieve any excess pressure before removing cap completely.**

1. Stop the engine and let it cool down.
2. Remove the drain plug (1) or disconnect the hose to drain the coolant. When removing the drain plug, set the hose to drain port.
3. Remove the radiator cap to completely drain the coolant.
4. After all coolant is drained, reinstall the drain plug (1).

Coolant	Capacity	8.7 L 9.2 U.S.qts. 7.7 Imp.qts.

(1) Drain Plug

12190S00380

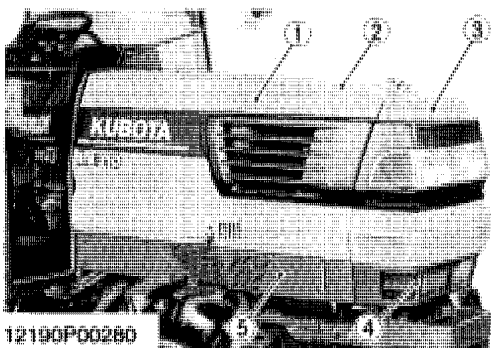

**Preparation 1**

1. Remove the side cover (1) from both sides and front mask (3).
2. Remove the front grille (4) and side skirt (5) both sides.
3. Disconnect the washer hose, then remove the bonnet (2).

- |                |                  |
|----------------|------------------|
| (1) Side Cover | (4) Front Grille |
| (2) Bonnet     | (5) Side Skirt   |
| (3) Front Mask |                  |

12190S00390

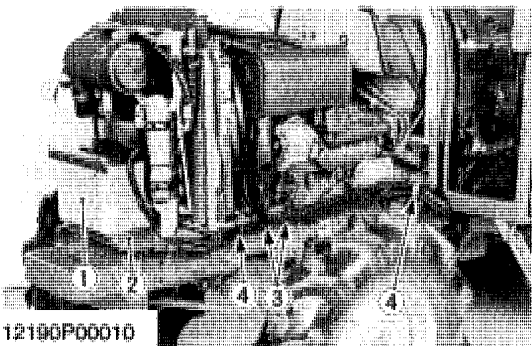

**Preparation 2**

**⚠ CAUTION**

- **When removing the battery cords from the battery, disconnect the negative first. When installing the battery cords to the battery, connect the positive cord first.**

1. Remove the battery (1).
2. Remove the plate (2).
3. Remove the hose clamps (3).
4. Remove the hose stay (4).

- |             |                |
|-------------|----------------|
| (1) Battery | (3) Hose Clamp |
| (2) Plate   | (4) Hose Stay  |

12190S00400

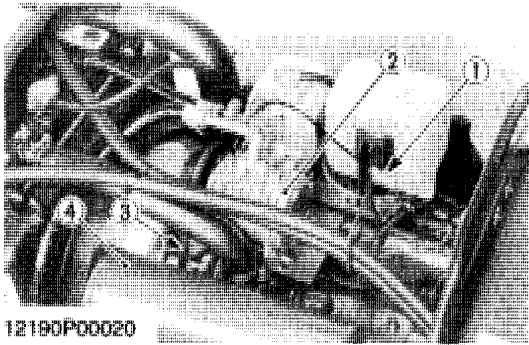

12190P00020

### Compressor

1. Remove the muffer (4).
2. Disconnect the 1P connector (1) for magnetic clutch.
3. Remove the air conditioner belt (3) and remove the compressor (2) mounting screws.

#### (When reassembling)

- After reassembling the compressor, be sure to adjust the air conditioner belt tension. (See page 10-G2.)

Tightening torque	Compressor mounting screws	24.5 to 29.4 N·m 2.5 to 3.0 kgf·m 18.1 to 21.7 ft·lbs
-------------------	----------------------------	---

- |                  |                          |
|------------------|--------------------------|
| (1) 1P Connector | (3) Air Conditioner Belt |
| (2) Compressor   | (4) Muffer               |

12190S00410

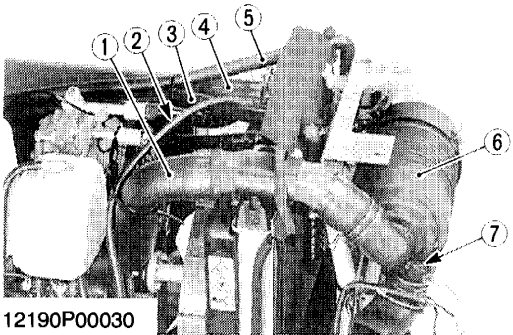

12190P00030

### Preparation 3

1. Disconnect the air cleaner hose (1).
2. Disconnect the air cleaner sensor (7) leads.
3. Disconnect the recovery tank hose (2) leads.
4. Disconnect the radiator upper hose (4).
5. Disconnect the oil cooler pipes (hoses) (3), (5). (If equipped.)
6. Remove the air cleaner a'ssy (6).

- |                            |                            |
|----------------------------|----------------------------|
| (1) Air Cleaner Hose       | (5) Oil Cooler Pipe (Hose) |
| (2) Recovery Tank Hose     | (6) Air Cleaner Assembly   |
| (3) Oil Cooler Pipe (Hose) | (7) Air Cleaner Sensor     |
| (4) Radiator Upper hose    |                            |

12190S00420

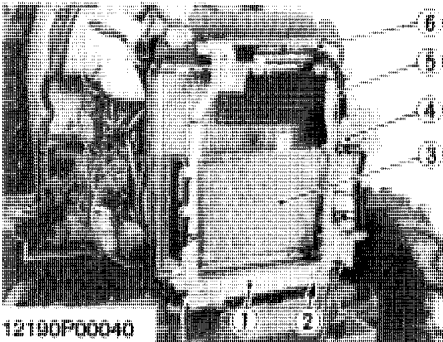

12190P00040

### Compressor, Condenser and Receiver

1. Remove the bonnet support (1) mounting screws (2).
2. Remove the hose clamp.
3. Take out the compressor (7), condenser (3), receiver (4), hoses (5), bonnet support (6) and etc. as a unit.

- |                    |                    |
|--------------------|--------------------|
| (1) Bonnet Support | (5) Hoses          |
| (2) Screws         | (6) Bonnet Support |
| (3) Condenser      | (7) Compressor     |
| (4) Receiver       |                    |

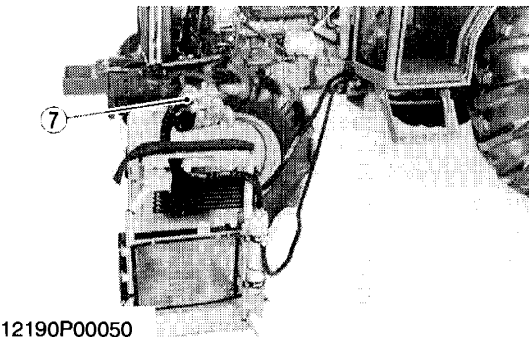

12190P00050

12190S00430



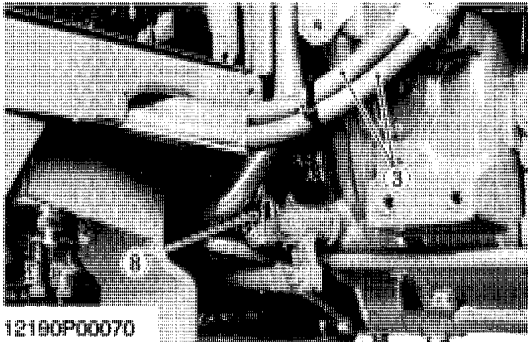
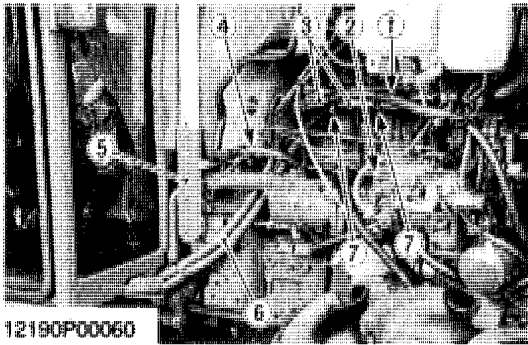

#### **Preparation 4**

1. Remove the accelerator rod (4).
2. Disconnect the engine stop cable (2).
3. Disconnect the meter cable (1).
4. Remove the pillar support (5).
5. Remove the cord bands (7) and hose stay (6).
6. Disconnect the heater hoses (3), then pull out them under the cabin.
7. Disconnect the brake rod RH (8).

#### **(When reassembling)**

- In assembling the heater hoses (2) to the water valve (5), connect the heater hose with identification mark (white paint) to upper side of the water valve (5).
- After reassembling the brake rod, be sure to adjust the brake pedal free travel. (See page 5-S3.)

- |                       |                    |
|-----------------------|--------------------|
| (1) Meter Cable       | (5) Pillar Support |
| (2) Engine Stop Cable | (6) Hose Stay      |
| (3) Heater Hoses      | (7) Cord Band      |
| (4) Accelerator Rod   | (8) Brake Rod, RH  |

12190S00440

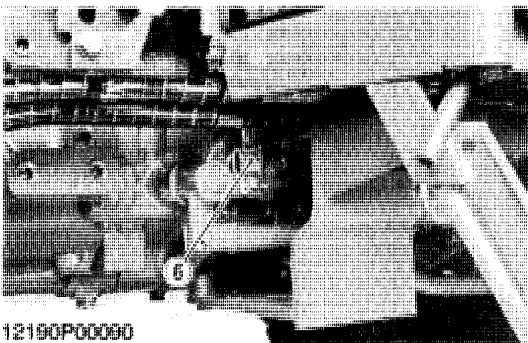
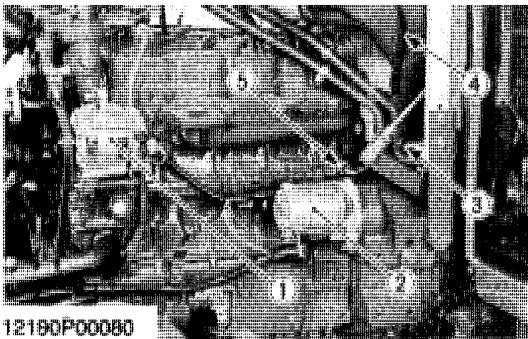

#### **Preparation 5**

1. Disconnect the 2P connector and jumper lead for alternator (1) and the jumper leads (4) for fuel level sensor, starter (2) connectors and engine oil switch (5) terminal, then remove the cord band (3).
2. Disconnect the brake rod LH (6).

#### **(When reassembling)**

- After reassembling the brake rod, be sure to adjust the brake pedal free travel. (See page 5-S3.)

- |                |                            |
|----------------|----------------------------|
| (1) Alternator | (4) Fuel Level Sensor Lead |
| (2) Starter    | (5) Engine Oil Switch      |
| (3) Cord Band  | (6) Brake Rod, LH          |

12190S00450

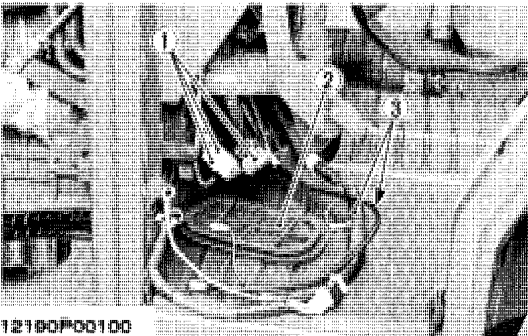

#### **Connectors**

1. Remove the rubber cover (2).
2. Pull out the wire harness (3) so that it can be seen.
3. Disconnect the three connectors (1) (white connectors).

- |                  |                  |
|------------------|------------------|
| (1) Connectors   | (3) Wire Harness |
| (2) Rubber Cover |                  |

12190S00460

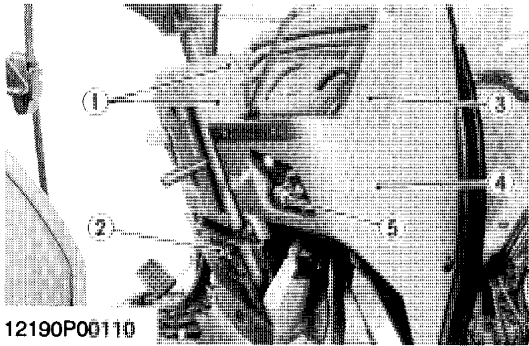

12190P00110

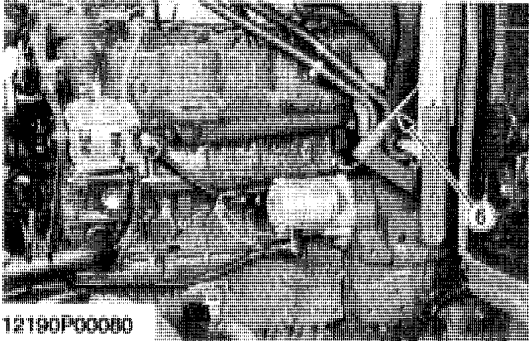

12190P00080

**Preparation 6**

1. Remove the steering post covers (1) and steering post under cover (2).
2. After tilting the steering wheel up, loosen and remove the meter panel (3) mounting screws, then lift the meter panel (3) up.
3. Disconnect the clutch rod (6) from both sides and remove it.

**(When reassembling)**

- After reassembling the clutch rod, be sure to adjust the clutch pedal free travel. (See page 2-S3.)

- |                               |                       |
|-------------------------------|-----------------------|
| (1) Steering Post Covers      | (4) Panel Under Cover |
| (2) Steering Post Under Cover | (5) Main Switch       |
| (3) Meter Panel               | (6) Clutch Rod        |

12190S00470

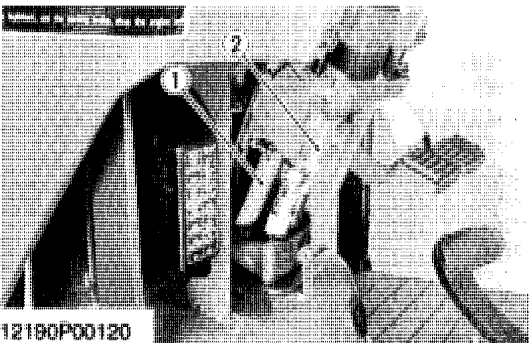

12190P00120

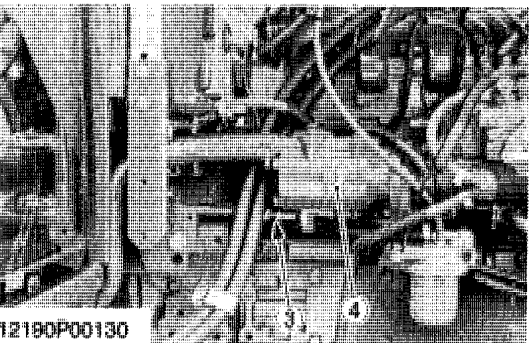

12190P00130

**Power Steering Hoses**

1. Disconnect the return hose (1) with the power steering controller (2).
2. Disconnect the main delivery hose (3) with the hydraulic pump (4).
3. Disconnect the right and left turning delivery hose (5), (6) with the hydraulic cylinder (7).

**(When reassembling)**

- When reassembling the turning delivery hoses to the steering controller, connect the delivery hose with identification mark (tape) "A" to the L port of the steering controller. (Refer to figure below.)

Tightening torque	Main delivery hose retaining nut	46.6 to 50.9 N·m 4.8 to 5.2 kgf·m 34.4 to 37.6 ft-lbs
	Turning delivery hose retaining nut	24.5 to 29.4 N·m 2.5 to 3.0 kgf·m 18.1 to 21.7 ft-lbs

- |                                 |                                       |
|---------------------------------|---------------------------------------|
| (1) Return Hose                 | (6) Left Turning Delivery Hose        |
| (2) Power Steering Controller   | (7) Hydraulic Cylinder                |
| (3) Main Delivery Hose          |                                       |
| (4) Hydraulic Pump              | <b>(A) Identification Mark (Tape)</b> |
| (5) Right Turning Delivery Hose |                                       |

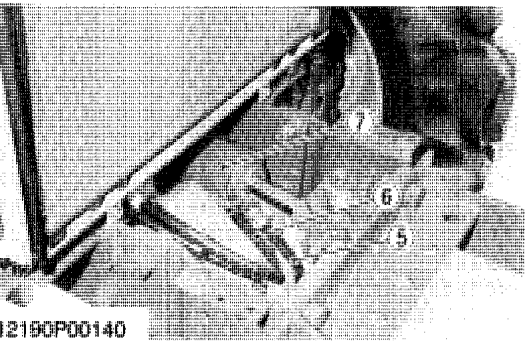

12190P00140

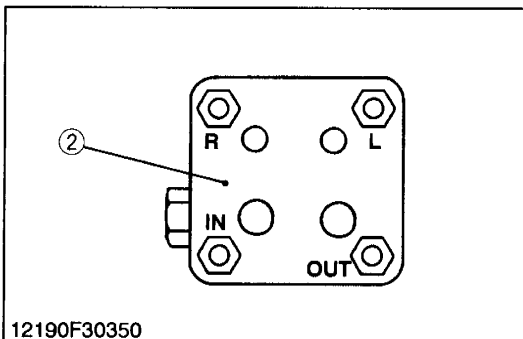

12190F30350

12190S00480

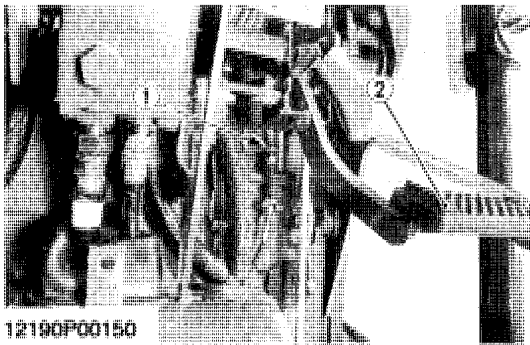

12190P00150

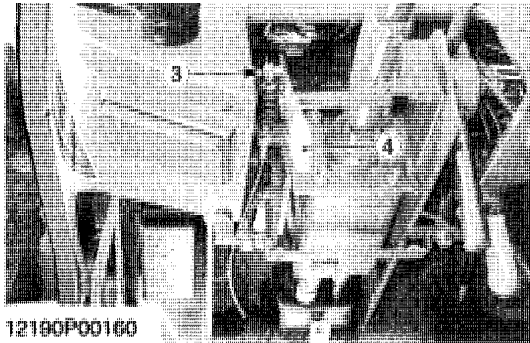

12190P00160

**Cruise Control Cable and HST Pedal Linkage**

1. Disconnect the cruise control cable (1) from the brake pedal (2).
2. Disconnect the cruise control cable (3) from the cruise lever (4).
3. Disconnect the HST pedal linkage (5) from the HST pedal (6).

- |                          |                       |
|--------------------------|-----------------------|
| (1) Cruise Control Cable | (4) Cruise Lever      |
| (2) Brake Pedal          | (5) HST Pedal Linkage |
| (3) Cruise Control Cable | (6) HST Pedal         |

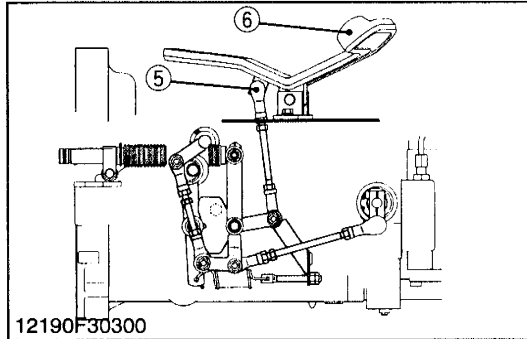

12190F30300

12190S00490

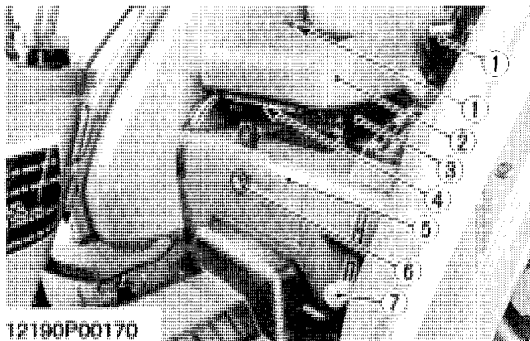

12190P00170

**Preparation 7**

1. Remove the seat (2) after pulling out the rod (4).
2. Remove the seat base (support) (3) with the safety seat belt (1).
3. Take out the auxiliary control lever grips (if equipped).
4. Take out the draft control lever grip (if equipped).
5. Disconnect the PTO limit switch (8) jumper leads.
6. Disconnect the PTO shift cable (10) to the PTO lever (9).
7. Disconnect the 1P connectors (11) for cigarette lighter.
8. Take out the lowering speed adjusting knob (6), then remove the seat under cover (5).
9. Remove the Mid PTO shift lever from the lower connector (if equipped). (Mid PTO type only.)
10. Loosen and remove the front wheel drive shift lever grip (7). (4WD type only.)

- |                                   |  |
|-----------------------------------|--|
| (1) Safety Seat Belt              | (7) Front Wheel Drive Shift Lever Grip |
| (2) Seat                          | (8) PTO Limit Switch                   |
| (3) Seat Base (Support)           | (9) PTO Lever                          |
| (4) Rod                           | (10) PTO Shift Cable                   |
| (5) Seat Under Cover              | (11) 1P Connectors                     |
| (6) Lowering Speed Adjusting Knob |  |

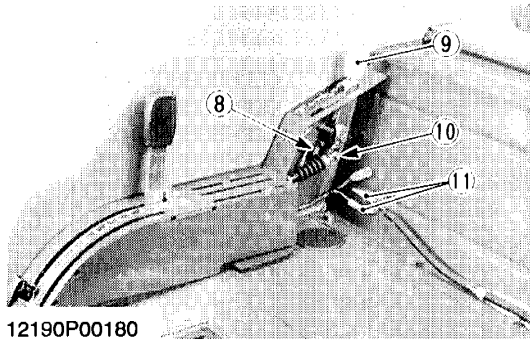

12190P00180

12190S00500

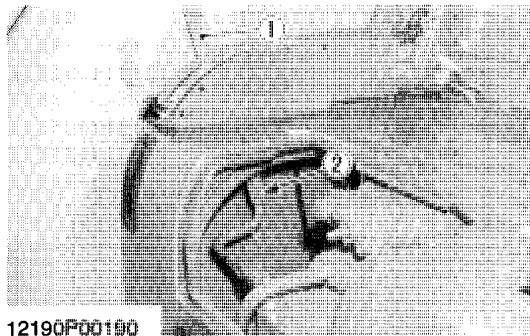

12190P00190

**Position Control Lever**

1. Remove the two screws to disconnect the position control lever (1) from the lower connection (2).

- |                            |                      |
|----------------------------|----------------------|
| (1) Position Control Lever | (2) Lower Connection |
|----------------------------|----------------------|

12190S00510

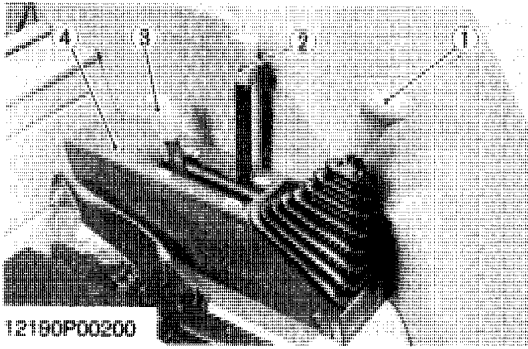

12190P00200

**Preparation 8**

**1) Manual Shift Type**

1. Loosen and remove the main gear shift lever grip (1).
2. Take out the creep speed shift lever grip (3) and Hi-Lo shift lever grip (2).
3. Remove the shift lever guide (4), then take out the boots.

- (1) Main Gear Shift Lever Grip                      (3) Creep Speed Shift Lever Grip
- (2) Hi-Lo Shift Lever Grip                         (4) Shift Lever Guide

12190S00520

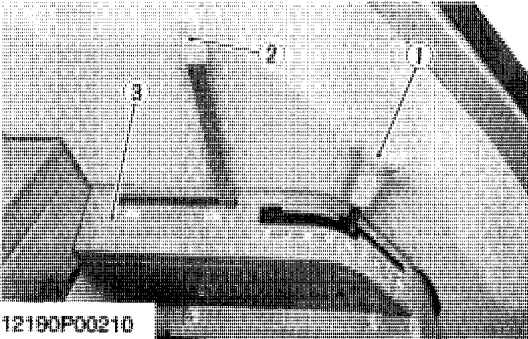

12190P00210

**2) GST Type**

1. Loosen and remove the main gear shift lever grip (1).
2. Take out the creep speed shift lever grip (2).
3. Remove the shift lever guide (3), then take out the rubber.
4. Remove the GST shift cable (4).

**(When reassembling)**

- Apply liquid gasket (Three Bond 1208D or equivalent) to the joint face between rotary valve cover and GST shift cable (4).
- Set GST shift lever to neutral position, then align the punched marks **(A)** of the rotary valve case and rotary valve shaft when installing the GST shift cable (4).

Tightening torque	GST shift cable mounting screws	7.8 to 8.8 N·m 0.8 to 0.9 kgf·m 5.8 to 6.5 ft·lbs
-------------------	---------------------------------	---

- (1) Main Gear Shift Lever Grip                      (4) GST Shift Cable
- (2) Creep Speed Shift Lever Grip
- (3) Shift Lever Grip                                      **(A) Punched Marks**

12190S00530

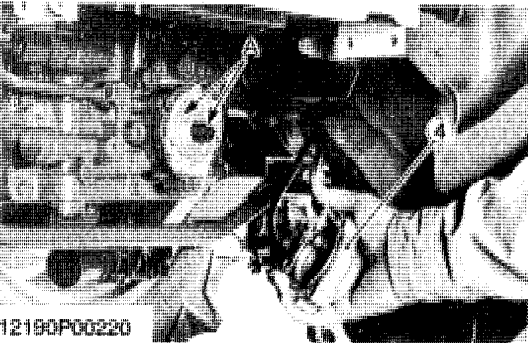

12190P00220

**2) HST Type**

1. Loosen and remove the auxiliary gear shift lever grip (2).
2. Remove the shift lever guide (1), then take out the shift lever guide rubber cover.

- (1) Shift Lever Guide                                      (2) Auxiliary Gear Shift (Lo-Me-Hi) Lever Grip

12190S00540

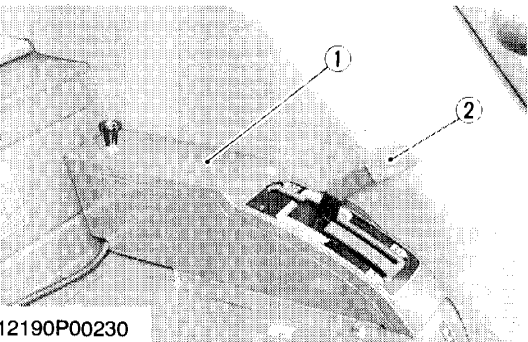

12190P00230

**Preparation 9**

1. Remove the extension shaft (1) of lowering speed adjusting valve.
2. Disconnect the differential lock rod (2).

- (1) Extension Shaft                                      (2) Differential Lock Rod

12190S00550

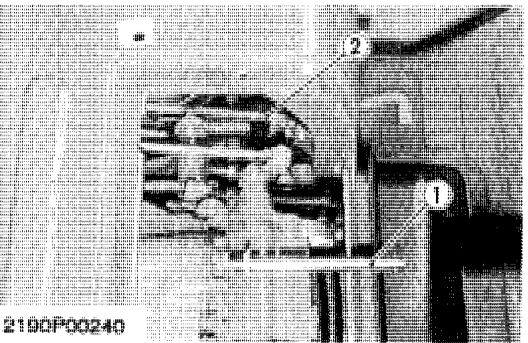

12190P00240

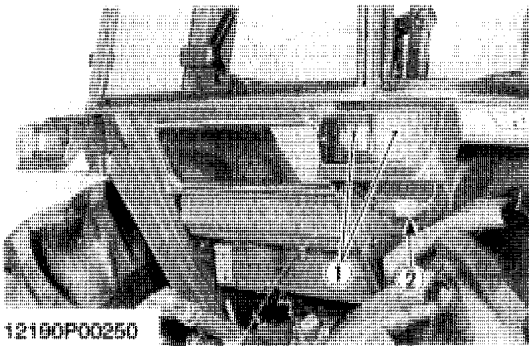

12190P00250

**Preparation 10**

1. Remove the quick coupler assembly (if equipped).
2. Disconnect the rear combination lamp (1) jumper leads (2) both sides.

- (1) Rear Combination Lamp                      (2) Jumper Leads

12190S00560

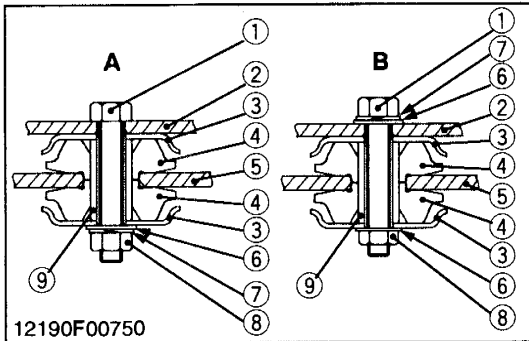

12190F00750

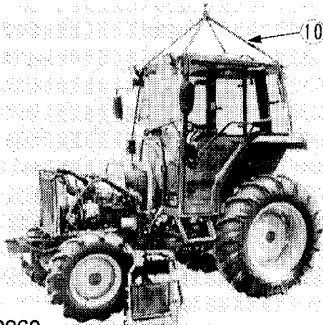

12190P00260

**Dismounting Cabin**

1. Remove the outer roof of cabin.
2. Support the cabin with nylon lift straps (10) and hoists.
3. Loosen and remove the cabin mounting screws (1) and nuts (8).
4. Dismounting the cabin from tractor body.

**NOTE**

- When lifting the cabin with the hoist, be sure not to drop the cabin mounting rubber, plate and washers.
- Set the front wheel drive shift lever to the 4WD position, and lift the cabin while making sure it doesn't catch on anything (4WD type only).
- Lift up and down the cabin with the hoist, pulling the front wheel drive shift lever backward by hand to prevent it interrupting with the cabin.

**(When reassembling)**

- Install the same washers as they were.

Tightening torque	Cabin mounting screws and nuts	123.5 to 147 N·m 13 to 15 kgf·m 91 to 108 ft-lbs
-------------------	--------------------------------	--

- |   |                       |
|---|-----------------------|
| (1) Cabin Mounting Screw                  | (7) Spring Washer     |
| (2) Bracket (Cabin Side)                  | (8) Nut               |
| (3) Plate                                 | (9) Collar            |
| (4) Rubber                                | (10) Nylon Lift Strap |
| (5) Cabin Mounting Bracket (Tractor Side) | (A) Front Side        |
| (6) Plain Washer                          | (B) Rear Side         |

12190S00570

## ADJUSTING

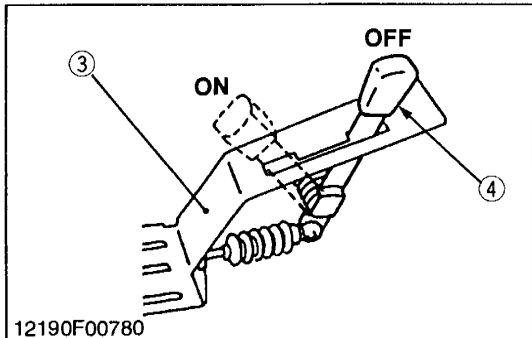
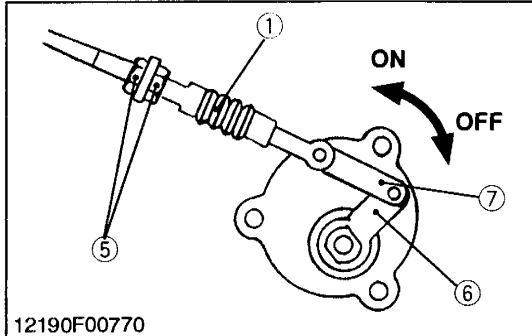
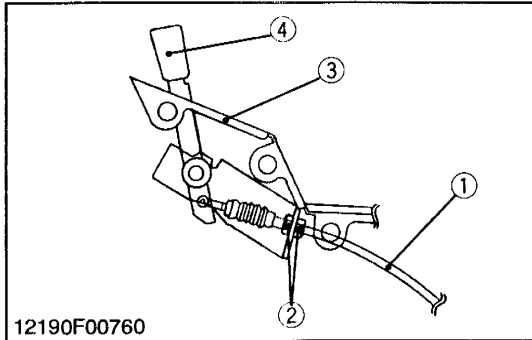

### PTO Shift Cable Adjustment

1. Tighten the lock nuts (2) at approximately center of the thread part on the PTO shift cable (1).
2. Set the PTO shift lever (4) to the **OFF** position.
3. Extend the PTO shift cable (1) until the PTO lever (6) moves at the transmission side, and then tighten the lock nuts (5).
4. Confirm following items after adjustment.
  - 4-1. The PTO shift lever (4) moves back to **OFF** position automatically when it is came off from the dent part of **ON** position by hand.
  - 4-2. The PTO shift lever (4) moves back to **OFF** position automatically when it is let go in between **ON** and **OFF**.
  - 4-3. The PTO shaft stops rotating when PTO shift lever (4) is shifted **OFF** position.
  - 4-4. The PTO shaft turns when PTO shift lever (4) is shifted **ON** position.

- |                     |                     |
|---------------------|---------------------|
| (1) PTO Shift Cable | (5) Lock Nut        |
| (2) Lock Nuts       | (6) PTO Lever       |
| (3) Lever Guide     | (7) PTO Lever Plate |
| (4) PTO Shift Lever |                     |



12190S00580

## [2] COMPRESSOR CHECKING

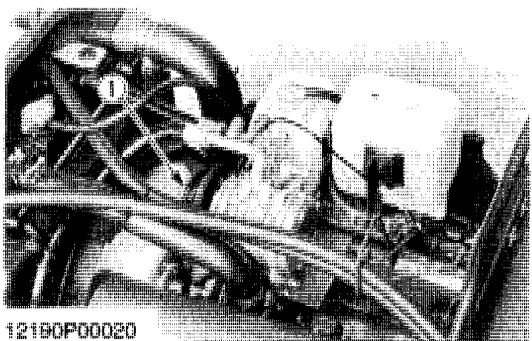

### Operation of Magnetic Clutch

1. Start the engine.
2. Check whether abrasion or abnormal noise is heard when only the magnetic clutch pulley is running while the A/C switch is turned **OFF**.
3. Check that the magnetic clutch (1) does not slip when the A/C switch and blower switch are turned **ON** (when the air conditioner is in operation).
4. If anything abnormal is found, repair or replace.

- |                     |
|---------------------|
| (1) Magnetic Clutch |
|---------------------|

12190S00590

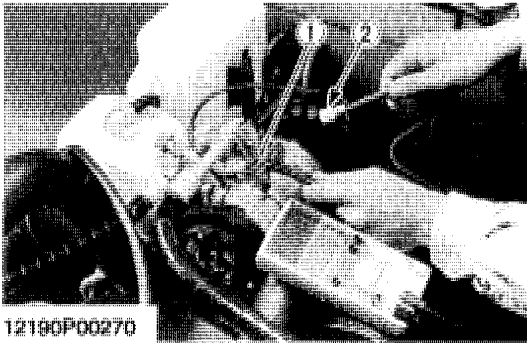

**Stator Coil**

1. Measure the resistance of the stator coil with an ohmmeter across the **1P** connector of magnetic clutch and stator body.
2. If the measurement is not within the factory specifications, replace the stator coil.

Stator coil resistance	Factory spec.	3.0 to 3.4 Ω
------------------------	---------------	--------------

(1) Stator Body

(2) 1P Connector

12190S00600

**DISASSEMBLING AND ASSEMBLING**

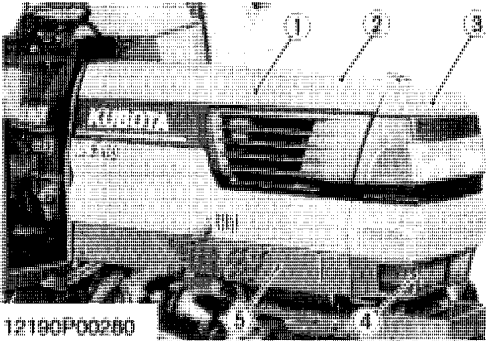

**Preparation**

1. Remove the side cover (1) both sides and front mask (3).
2. Disconnect the washer hose, then remove the bonnet (2).
3. Disconnect the battery negative cord.

- (1) Side Cover
- (2) Bonnet
- (3) Front Mask

- (4) Front Grille
- (5) Side Skirt

12190S00610

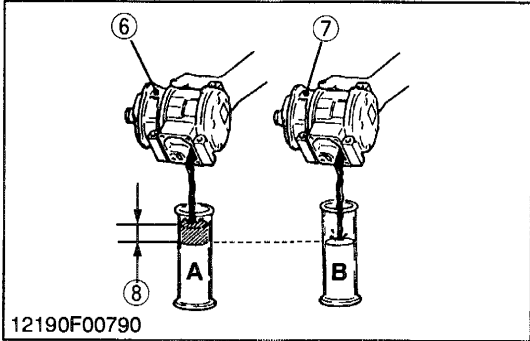
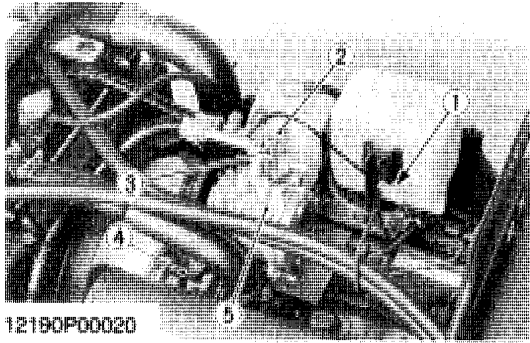

**Compressor**

1. Discharge the refrigerant from the system. (Refer to “Discharging the System” : See page 10-S16.)
2. Disconnect the low pressure pipe (suction) (3) and high pressure pipe (discharge) (2) from the compressor, then cap the open fittings immediately to keep moisture out of the system.
3. Disconnect the 1P connector (1) of magnetic clutch.
4. Remove the air conditioner belt (4) and remove the compressor (5).

**(When reassembling)**

- After reassembling the compressor, be sure to adjust the air conditioner belt tension (see page 10-G2) and recharge the refrigerant to the system. (Refer to “Charging the System” : See page 10-S18.)
- Apply compressor oil (**NIPPONDENSO ND-OIL8** or equivalent) to the O-rings and take care not to damage them.
- “S” letter is marked on the compressor for connecting the low pressure pipe (suction side).
- “D” letter is marked on the compressor for connecting the high pressure pipe (discharge side).

**(When replacing compressor)**

- When replacing the compressor with a new one, meet the oil amount with old one.

Tightening torque	High pressure pipe and low pressure pipe mounting screw	3.9 to 6.9 N·m 0.40 to 0.70 kgf·m 2.9 to 5.1 ft·lbs
	Compressor mounting screws	24.5 to 29.4 N·m 2.5 to 3.0 kgf·m 18.1 to 21.7 ft·lbs

- |                          |                                 |
|--------------------------|---------------------------------|
| (1) 1P Connector         | (5) Compressor                  |
| (2) High Pressure Pipe   | (6) New Compressor              |
| (3) Low Pressure Pipe    | (7) Old Compressor              |
| (4) Air-conditioner Belt | (8) Remove the Excess Oil (A-B) |

12190S00620

**[3] AIR CONDITIONER SYSTEM AND FRONT WINDSHIELD WIPER CHECKING**

**(1) Air Conditioner Unit**

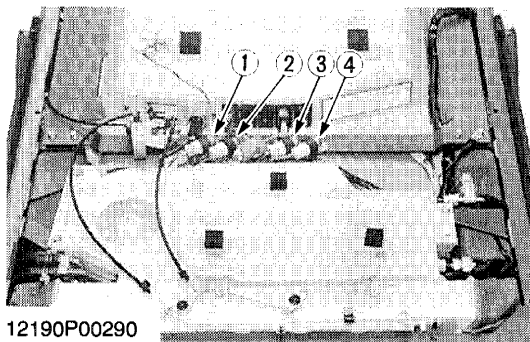

**A/C Relay**

1. Remove the outer roof of cabin, and disconnect the A/C relay (1), (2), (3), (4) connectors.
2. Perform the following checkings 1) and 2).
 

(1) A/C Relay (Blower HI)	(3) A/C Relay (Blower ME)
(2) A/C Relay (Blower LO)	(4) A/C Relay (Compressor)

12190P00290

12190S00630



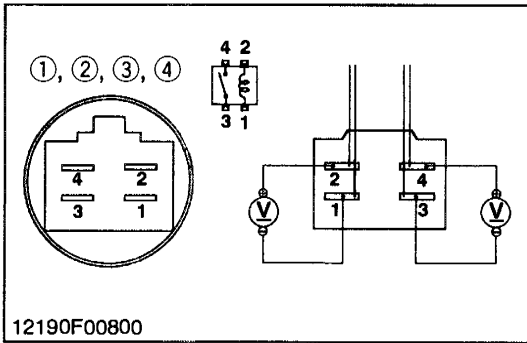

12190F00800

- (1) A/C Relay (Blower HI)
- (2) A/C Relay (Blower LO)
- (3) A/C Relay (Blower ME)
- (4) A/C Relay (Compressor)

**1) Connector Voltage**

**a) A/C Relay (Blower HI)**

1. When turning the main switch **ON** and blower switch to **HI** position, the voltage across the **2** terminal and chassis should be approx. battery voltage.

**b) A/C Relay (Blower LO)**

1. The voltage across the **4** terminal and chassis should be approx. battery voltage.
2. When turning the main switch **ON** and blower switch to **LO** position, the voltage across the **2** terminal and chassis should be approx. battery voltage.

**c) A/C Relay (Blower ME)**

1. When turning the main switch **ON** and blower switch to **ME** position, the voltage across the **2** terminal and chassis should be approx. battery voltage.

**d) A/C Relay (Compressor)**

1. The voltage across the **4** terminal and chassis should be approx. battery voltage.
2. When turning the main switch **ON**, blower switch to **LO** and A/C switch **ON**, the voltage across the terminal **2** and chassis should be approx. battery voltage.

12190S00640

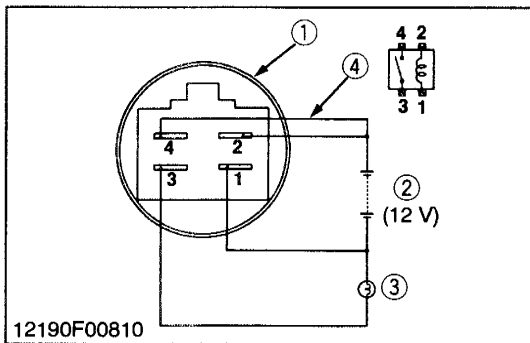

12190F00810

**2) A/C Relay Test**

1. Remove the A/C relay (1).
2. Connect the battery (2) and bulb (3) with the A/C relay (1) as shown in the left figure.
3. In this condition, the bulb should light on if the A/C relay is proper.
4. If the bulb light off when disconnecting the jumper lead (4) from the A/C relay 4 terminal, the A/C relay is proper.

- (1) A/C Relay
- (2) Battery
- (3) Bulb
- (4) Jumper Lead

12190S00650

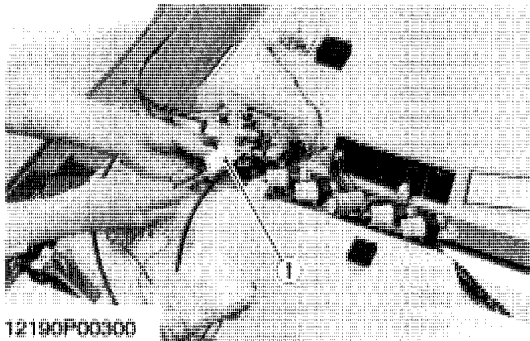

12190F00300

**A/C Blower Switch**

1. Remove the outer roof and disconnect the A/C blower switch connector (1).
2. Perform the following checkings 1) and 2).

- (1) A/C Blower Switch Connector

12190S00660

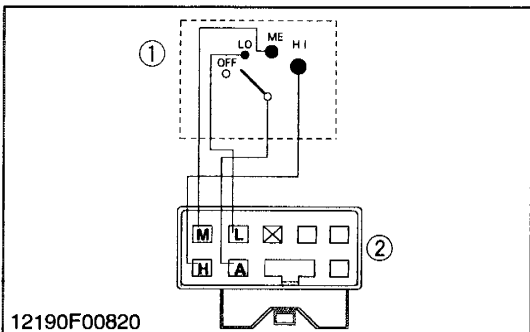

12190F00820

**1) Connector Voltage**

1. Turn the main switch **ON**.
2. Measure the voltage with a voltmeter across the connector **L** terminal and **A** terminal.
3. If the voltage differs from the battery voltage, the wiring harness, A/C relay, fuse or main switch is faulty.

Voltage	L terminal – A terminal	Approx. battery voltage
---------	-------------------------	-------------------------

- (1) A/C Blower Switch
- (2) A/C Blower Switch Connector
- (A) From Main Switch A/C Terminal

12190S00670

**2) A/C Blower Switch**

1. Check the continuity through the switch with an ohmmeter.
2. If the continuity specified below are not indicated, the switch is faulty.

Position \ Terminal		A	L	M	N
		OFF	●		
A/C blower switch	● (Low)	●	●		
	● (Medium)	●		●	
	● (High)	●			●

12190S00680

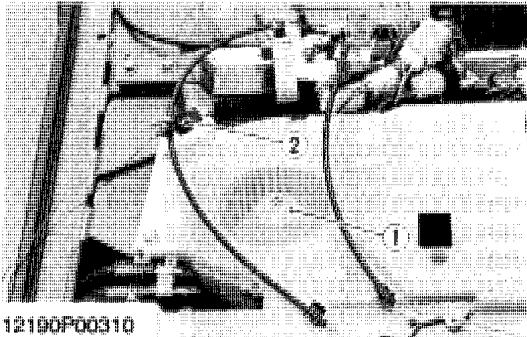

12190P00310

**A/C Blower Motor Test**

1. Remove the outer roof.
2. Turn the blower motor (1) by hand and check whether it turns smoothly.
3. Disconnect the connector (2) of blower motor (1).
4. Connect a jumper lead from battery (3) positive terminal to connector B terminal.
5. Connect a jumper lead from battery negative terminal to connector E terminal momentarily.
6. If the blower motor does not run, check the motor.

- (1) Blower Motor (3) Battery (12 V)  
 (2) Blower Motor Connector

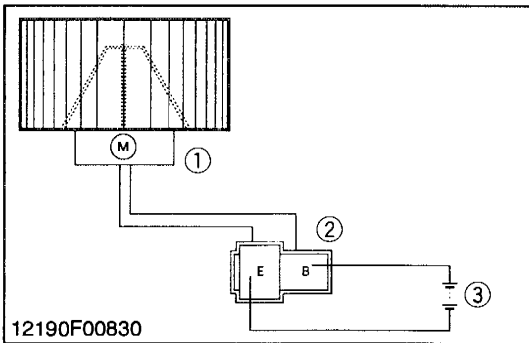

12190F00830

12190S00690

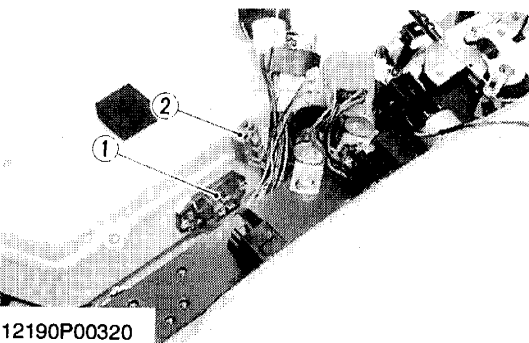

12190P00320

**A/C Blower Resistor**

1. Remove the outer roof.
2. Disconnect the 4P connector (2) for A/C blower resistor (1).
3. Measure the resistance with an ohmmeter across the R1 terminal and E terminal, and across the R2 terminal and E terminal.
4. If the factory specifications are not indicated, A/C blower resistor is faulty.

Resistance	Factory spec.	R1 terminal – E terminal	Approx. 0.9 ohm
		R2 terminal – E terminal	Approx. 1.8 ohm

- (1) A/C Blower Resistor (2) A/C Blower Resistor Connector

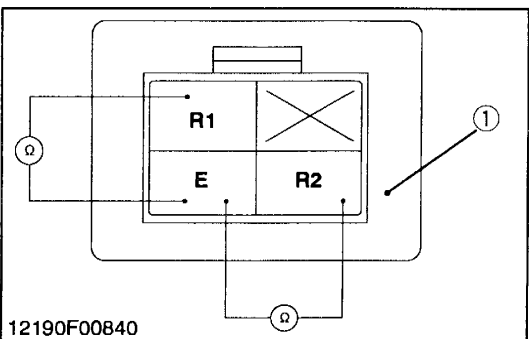

12190F00840

12190S00700

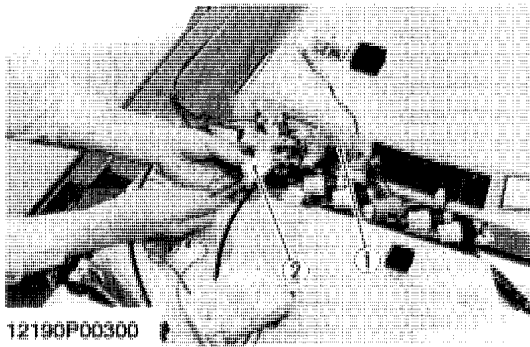

12190F00300

**A/C Switch**

1. Remove the outer roof, and disconnect the A/C switch connector (2).
2. Perform the flooring checkings 1) and 2).

(1) A/C Switch

(2) A/C Switch Connector

12190S00710

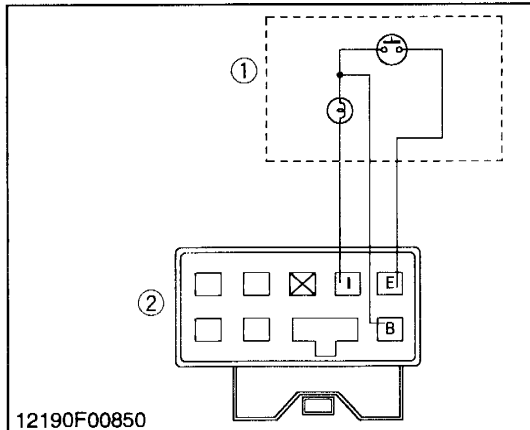

12190F00850

**1) Connector Voltage**

1. Turn the main switch **ON**.
2. Measure the voltage with a voltmeter across the connector **B** terminal and **E** terminal.
3. If the voltage differs from the battery voltage, the wiring harness, A/C relay or fuse is faulty.

Voltage	<b>B</b> terminal -- <b>E</b> terminal	Approx. battery voltage
---------	--	-------------------------

**2) A/C Switch**

1. Check the continuity through the switch with an ohmmeter.
2. If the continuity specified below is not indicated, the switch is faulty.

Position \ Terminal		<b>B</b>	<b>E</b>	<b>I</b>
		<b>OFF</b> *2	●	●
<b>A/C switch</b>	<b>ON</b> *1	●	●	●

\*1 : Push the A/C switch button to **ON** position.

\*2 : Push again the A/C switch button to **OFF** position.

(1) A/C Switch

(2) A/C Switch Connector

12190S00720

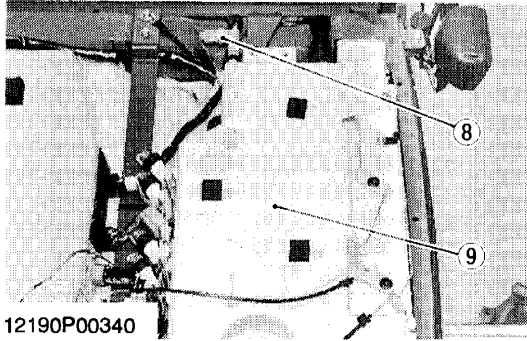
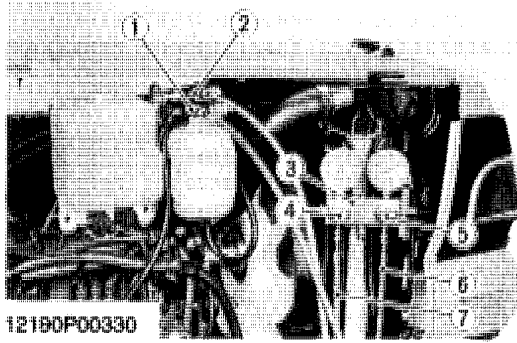

**Pressure Switch**

**1) HI Pressure Side**

1. Connect the manifold gauge (3) to compressor as following procedure.  
Close the **HI** and **LO** pressure valves (5), (4) of manifold gauge tightly, and connect the charging hoses (red and blue) (6), (7) to the respective compressor service valves. (Refer to **HANDLING OF SERVICE TOOLS** : See page 10-S8.)

**NOTE**

- **Be sure to drive out the air in the charging hoses at the manifold gauge connection end by utilizing the refrigerant pressure in the refrigerant cycle.**
2. Start the engine and set at approx. 1500 rpm. Turn on the A/C switch, then set the blower switch to **HI** position.
  3. Raise pressure on the **HI** pressure side of the refrigerant cycle by covering the condenser front with a corrugated carboard, and the dual switch (8) is activated and the compressor magnetic clutch is turned off. At this time, read the **HI** pressure gauge of the manifold gauge. If this pressure reading differs largely with the setting pressure, replace the pressure switch with a new one.

Setting pressure	Factory spec.	Dual switch <b>OFF</b>	More than approx. 3.14 MPa 32 kgf/cm <sup>2</sup> 455 psi
------------------	---------------	---------------------------	--

**2) LO Pressure Side**

1. Disconnect **2P** connector of pressure switch.
2. Measure the resistance with an ohmmeter across the connector terminals.
3. If 0 Ω is not indicated at normal condition, there is no refrigerant in the refrigerating cycle because gas leaks or pressure switch is defective.

**(Reference)**

Setting pressure	Factory spec.	Dual switch <b>OFF</b>	Less than approx. 0.196 MPa 2.0 kgf/cm <sup>2</sup> 28.4 psi
------------------	---------------	---------------------------	---

- The resistance of dual switch is 0 Ω in normal running, but is becomes infinity if the pressure is abnormal (out of factory spec.). Because the dual switch starts to work.

- |   |                              |
|---|------------------------------|
| (1) <b>HI</b> (High Pressure Side) Charging Valve | (5) <b>HI</b> Pressure Valve |
| (2) <b>LO</b> (Low Pressure Side) Charging Valve  | (6) Charging Hose (Red)      |
| (3) Manifold Gauge                                | (7) Charging Hose (Blue)     |
| (4) <b>LO</b> Pressure Valve                      | (8) Pressure Switch          |
|   | (9) Air Conditioner Unit     |

12190S00730

## (2) Front Windshield Wiper

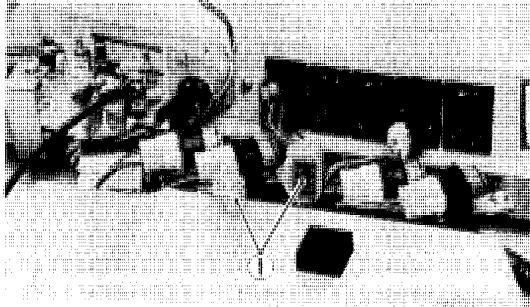

12190P00350

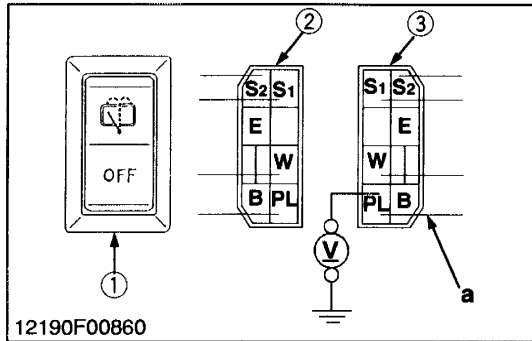

12190F00860

### Front Wiper Switch

1. Remove the outer roof, and disconnect the front wiper switch connector (1).
2. Perform the following checkings 1) and 2).

(1) Front Wiper Switch Connector

12190S00740

#### 1) Connector Voltage

1. Turn the main switch **ON**.
2. Measure the voltage with a voltmeter across the connector **W** terminal and chassis.
3. If the voltage differs from the battery voltage, the wiring harness, fuse or main switch is faulty.

Voltage	B terminal – Chassis	Approx. battery voltage
---------	----------------------	-------------------------

#### 2) Front Wiper Switch

1. Check the continuity through the switch with an ohmmeter.
2. If continuity specified below is not indicated, the switch is faulty.

Position		Terminal					
		S1	S2	B	W	E	PL
Front wiper switch	WASH I				●	●	●
	OFF	●	●			●	●
	↓	×		×			
	ON		●	●		●	●
	WASH II		●	●	●	●	●

#### (Reference)

- WASH I ..... **OFF** side of the wiper switch remains pushed in.
- WASH II ..... **ON** side remains pushed in after the wiper switch is switched **ON** and remains switched **ON**.

(1) Front Wiper Switch

(3) Front Wiper Switch Connector

(2) Front Wiper Switch Connector  
(Switch Side)

(Wiring Harness Side)

(a) From Main Switch AC Terminal

12190S00750

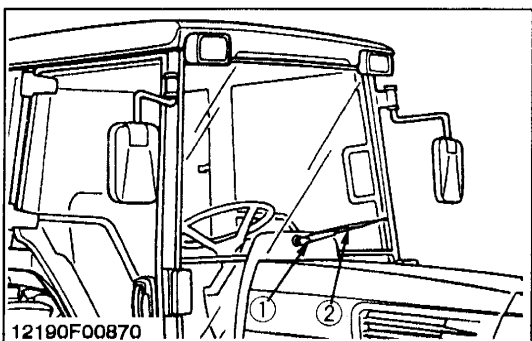

12190F00870

### Front Wiper Motor

1. Raise up the front wiper arm (1).
2. Turn the main switch **ON**.
3. Push the front wiper switch to **ON** position.
4. Count the number of wiper arm rocking per minutes.
5. If the number differs from the factory specifications, replace the wiper motor assembly.

No load rotating speed	Factory spec.	33 to 43 rpm
------------------------	---------------	--------------

(1) Wiper Arm

(2) Wiper Blade

12190S00760

# DISASSEMBLING AND ASSEMBLING

## (1) Removing Air Conditioner Unit and Front Wiper Motor

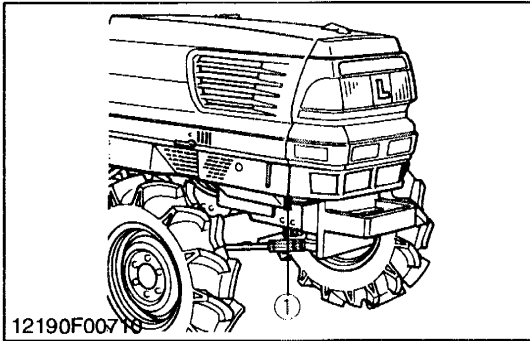

12190F00718

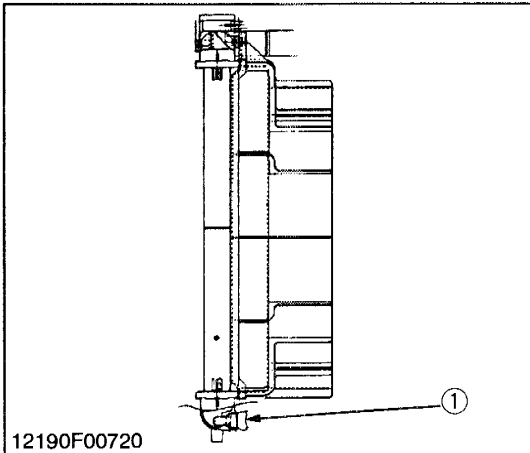

12190F00720

### Draining Coolant

#### CAUTION

- Never remove the radiator cap until coolant temperature is well below its boiling point. Then loosen cap slightly to relieve any excess pressure before removing cap completely.

1. Stop the engine and let it cool down.
2. Remove the drain plug (1) or disconnect the hose to drain the coolant. When removing the drain plug, set the hose to drain port.
3. Remove the radiator cap to completely drain the coolant.
4. After all coolant is drained, reinstall the drain plug (1).

Coolant	Capacity	8.7 L 9.2 U.S.qts. 7.7 Imp.qts.

(1) Drain Plug

12190S00380

### Discharging Refrigerant

- Refer to "Discharging the System". (See page 10-S16.)

12190S00780

### Preparation 1

1. Remove the outer roof.
2. Disconnect the battery negative cable.
3. Disconnect the A/C blower motor connector (1).
4. Disconnect the 4P connector for A/C blower resistor (2).

(1) A/C Blower Motor Connector  
(2) A/C Blower Resistor

(3) A/C Blower Resistor Connector

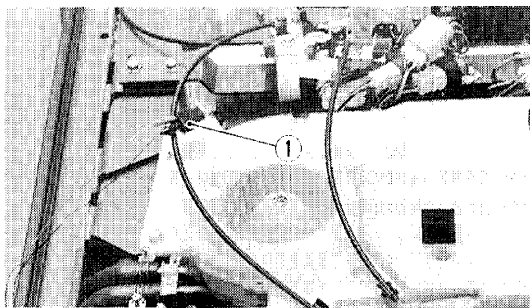

12190P00310

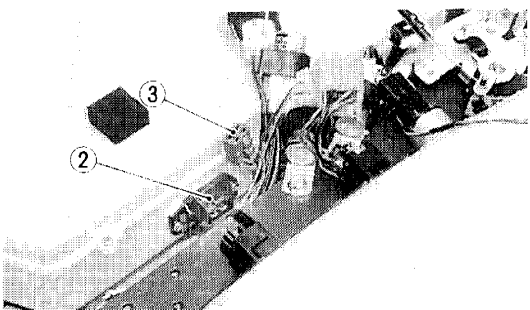

12190P00320

12190S00790

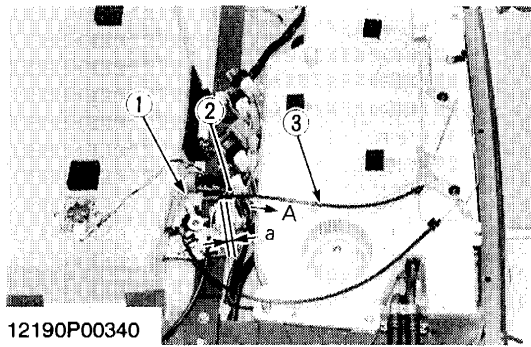

### Air Mixing Door Control Cable (Blue Cable)

1. Disconnect the air mixing door control cable (3) from the damper lever (1) of air conditioner control panel side.

#### **(When reassembling)**

- Set the damper lever (1) of the air conditioner unit at **MAX HOT** position. Reconnect the cable.
- Move the control to **MAX HOT** position. Fit the inner cable in position, and press and fix the outer cable by the cable clip (2) in the direction of arrow (A) as shown at left.
- Move the temperature control lever several times and finally set it to **MAX HOT** position to make sure the damper lever is at **HOT** position too.

- |                                   |                                      |
|-----------------------------------|--------------------------------------|
| (1) Damper Lever                  | (a) 5 to 10 mm (0.20 to 0.40 in.)    |
| (2) Cable Clip                    |                                      |
| (3) Air Mixing Door Control Cable | (A) Direction of Pulling Outer Cable |

12190S00800

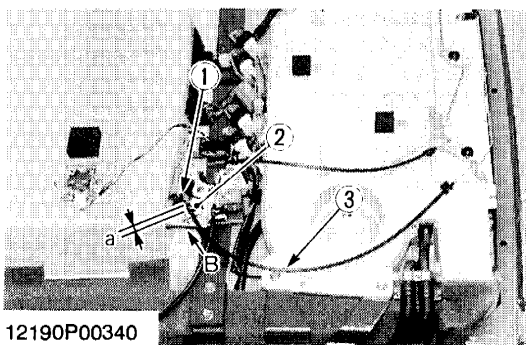

### A/C Mode Door Control Cable (Yellow Cable)

1. Disconnect the air conditioner mode door control cable (3) from the def. control lever (1) of A/C control panel side.

#### **(When reassembling)**

- Set the air conditioner unit to **DEF** mode position and reconnect the cable (3).
- Set the control at **DEF** position. Fit the inner cable in position, and press and fix the outer cable by the cable clip (2) in the direction of arrow (B) as shown at left.
- Move the mode lever several times and finally set it to **DEF** position to make sure the air conditioner unit is at **DEF** mode position.
- Lay and fix the mode door control cable over the water valve cable.

- |                             |                                      |
|-----------------------------|--------------------------------------|
| (1) DEF. Control Lever      | (a) 5 to 10 mm (0.20 to 0.40 in.)    |
| (2) Cable Clip              |                                      |
| (3) Mode Door Control Cable | (B) Direction of Pushing Outer Cable |

12190S00810

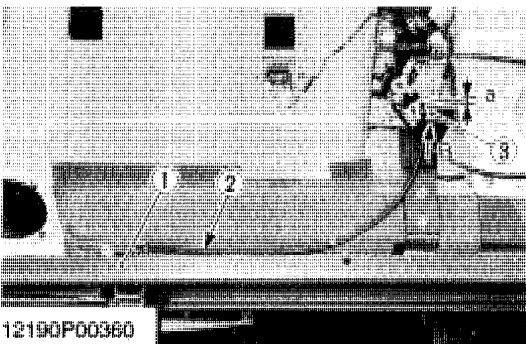

### Water Valve Control Cable (White Cable)

1. When disconnecting the water valve cable (2), follow the next reassembly procedure.

#### **(When reassembling)**

- Fully close the water valve (1) and reconnect the cable (2).
- Set the control at **MAX COOL** position. Fit the inner cable in position, and press and fix the outer cable by the cable clip (3) in the direction of arrow (A) as shown at left.
- Move the temperature control lever several times to make sure the water valve is fully closed at **MAX COOL** position.
- Do not allow the water valve cable to bend just away from the control, nor to get caught by the outer roof.

- |                               |                                      |
|-------------------------------|--------------------------------------|
| (1) Water Valve               | (a) 5 to 10 mm (0.20 to 0.40 in.)    |
| (2) Water Valve Control Cable |                                      |
| (3) Cable Clip                | (B) Direction of Pushing Outer Cable |

12190S00820

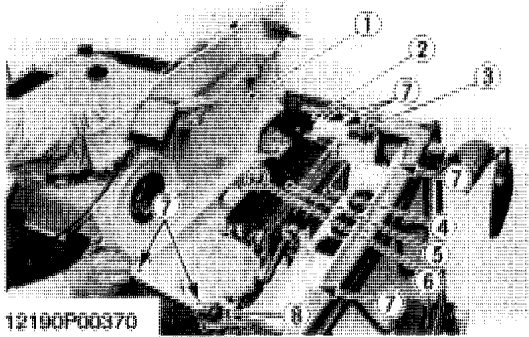

### **Air Conditioning Unit**

1. Remove the unit cover (1).
2. Disconnect the heater hoses (8).
3. Disconnect the cooler pipe (liquid) (2) and coolerpipe (suction side) (3).
4. Remove the five screws (7) and take off the unit.
5. Remove the duct hoses.

### **(When reassembling)**

- When reconnecting the cooler pipes with the unit, apply compressor oil (NIPPON-DENSO-OIL8 or equivalent) to O-rings.
- When remounting the unit, tighten five screw by hand and finally retighten them after aligning the inner roof duct with the unit duct.

Tightening torque	A/C unit mounting screw (M6)	3.92 to 6.86 N·m 0.40 to 0.70 kgf·m 2.89 to 5.06 ft-lbs
	A/C unit mounting screw (M8)	9.8 to 11.68 N·m 1.00 to 1.19 kgf·m 7.23 to 8.6 ft-lbs
	Low pressure pipe (Cooler pipe (suction)) retaining nut	29.4 to 34.3 N·m 3.0 to 3.5 kgf·m 21.7 to 25.3 ft-lbs
	High pressure pipe 1 (Cooler pipe (liquid)) retaining nut	11.8 to 14.7 N·m 1.2 to 1.5 kgf·m 8.7 to 10.8 ft-lbs

- |   |                     |
|---|---------------------|
| (1) Unit Cover  | (4) Heater Core     |
| (2) High Pressure Pipe 2 (Cooler Pipe (Liquid)) (High Pressure) | (5) Evaporator      |
| (3) Low Pressure Pipe (Cooler Pipe (Suction Side))              | (6) Expansion Valve |
|   | (7) Screws          |
|   | (8) Heater Hoses    |

12190S00830



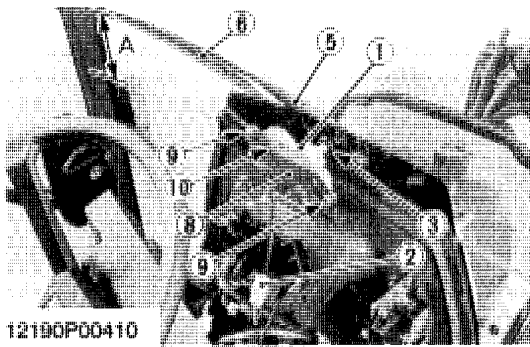

12190P00410

**Front Wiper Motor**

1. Remove the steering post covers and steering post under cover.
2. Remove the meter panel.
3. Remove the panel under cover.
4. Disconnect the front wiper motor **4P** connector (2).
5. Remove the wiper arm mounting nut (4) and wiper arm (5).
6. Remove the wiper link cap (3).
7. Disconnect the earth lead setting screw (10).
8. Remove the front wiper motor bracket (8) mounting screw (9) and nut (7), then take out the front wiper motor (1).

**(When reassembling)**

- When attaching the wiper arm (5) to the wiper motor (1), assemble so that the dimensions are as given in the photo on the left. After doing so, check if the wiper wipes symmetrically on the left and right (bilateral symmetry).

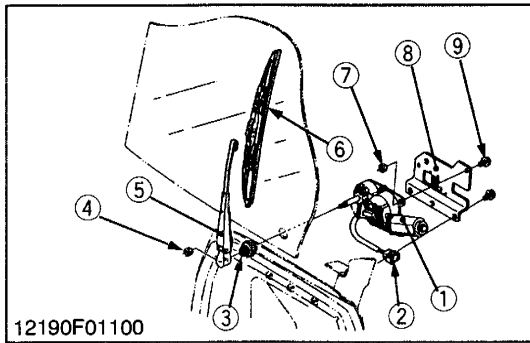

12190F01100

Tightening torque	Wiper arm mounting nut (6)	6.37 to 9.32 N-m 0.65 to 0.95 kgf-m 4.7 to 6.9 ft-lbs
	Wiper motor mounting nut (5)	2.5 to 3.4 N-m 0.25 to 0.35 kgf-m 1.9 to 2.5 ft-lbs

Distance "A"	Factory spec.	90 to 110 mm 3.5 to 4.3 in.
--------------	---------------	--------------------------------

- |   |  |
|---|--|
| (1) Front Wiper Motor                         | (7) Nut                                |
| (2) Front Wiper Motor Connector ( <b>4P</b> ) | (8) Wiper Motor Mounting Bracket       |
| (3) Wiper Link Cap                            | (9) Wiper Motor Bracket Mounting Screw |
| (4) Nut                                       | (10) Earth Lead Setting Screw          |
| (5) Wiper Arm                                 |  |
| (6) Wiper Blade                               |  |

12190S00840

**(2) Removing Air Conditioner Pipes**

**Discharging Refrigerant**

1. Refer to "Discharging the System" (See page 10-S16.)

12190S00850

**Preparation 1**

1. Remove the front mask (3) and side cover (1) both sides.
2. Remove the front grille (4) and side skirt (5) both sides.
3. Disconnect the washer hose, then remove the bonnet (2).

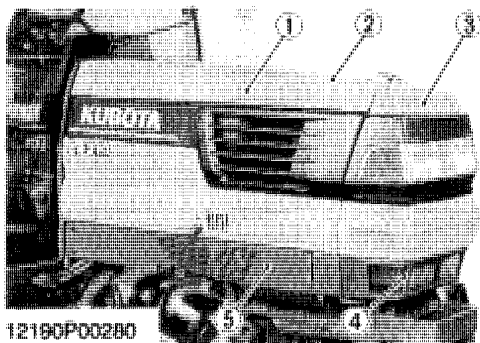

12190P00280

- |                |                  |
|----------------|------------------|
| (1) Side Cover | (4) Front Grille |
| (2) Bonnet     | (5) Side Skirt   |
| (3) Front Mask |                  |

12190S00860

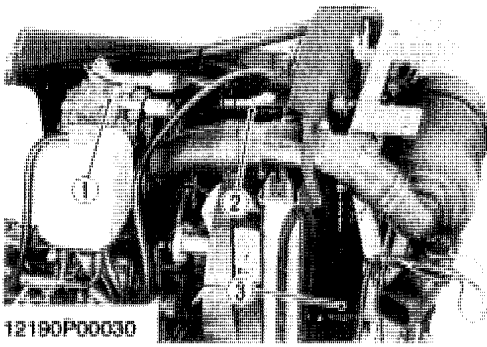

**High Pressure Pipe 1**

1. Disconnect the high pressure pipe 1 (2) from the compressor (1) and condenser (3), then cap the open fittings immediately to keep moisture out of the system.

**(When reassembling)**

- Apply compressor oil (NIPPONDENSO ND-OIL8 or equivalent) to the O-rings and take care not to damage them.

Tightening torque	High pressure pipe 1 mounting screw (Compressor side)	3.9 to 6.9 N·m 0.4 to 0.7 kgf·m 2.9 to 5.1 ft-lbs
	High pressure pipe 1 retaining nut (Condenser side)	19.7 to 24.5 N·m 2.0 to 2.5 kgf·m 14.5 to 18.0 ft-lbs

- (1) Compressor (3) Condenser  
(2) High Pressure Pipe 1

12190S00870

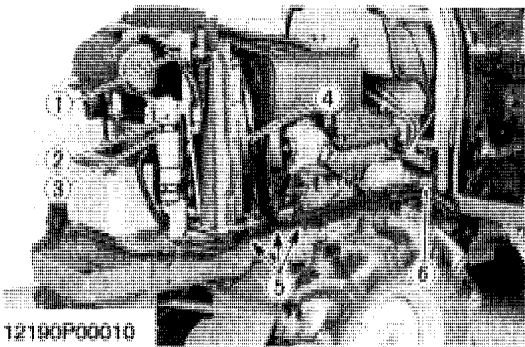

**Preparation 2**

1. Remove the hose clamp (5).
2. Remove the hose holder (6).
3. Disconnect the high pressure pipe 2 (3) from the receiver (2) and low pressure pipe (4) from the compressor, then cap the open fittings immediately to keep moisture out of the system.

**(When reassembling)**

- Apply compressor oil (NIPPONDENSO ND-OIL8 or equivalent) to the O-rings and take care not to damage them.

Tightening torque	High pressure pipe 2 retaining nut (Receiver side)	11.7 to 14.7 N·m 1.2 to 1.5 kgf·m 8.7 to 10.8 ft-lbs
	Low pressure pipe mounting screw (Compressor side)	3.9 to 6.9 N·m 0.4 to 0.7 kgf·m 2.9 to 5.1 ft-lbs

- (1) High Pressure Pipe 1 (4) Low Pressure Pipe  
(2) Receiver (5) Hose Clamp  
(3) High Pressure Pipe 2 (6) Hose Holder

12190S00880

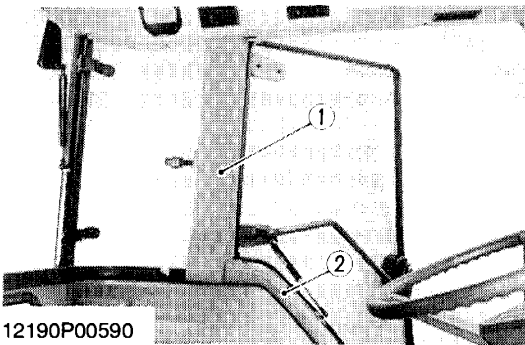

**Inner Covers**

1. Remove the inner covers (1) and (2).

- (1) Inner Cover (Upper) (2) Inner Cover (Lower)

12190S00890

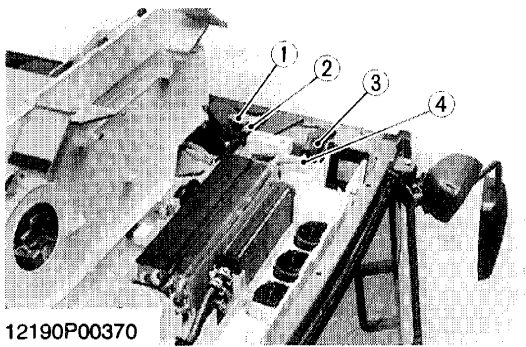

12190P00370

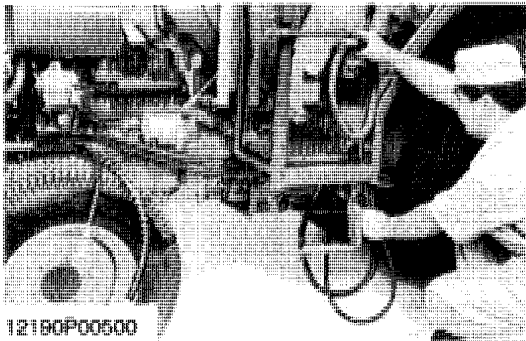

12190P00500

**Removing High Pressure and Low Pressure Pipes**

1. Remove the outer roof.
2. Disconnect the pressure switch (1) connector.
3. Disconnect the high pressure pipe 2 (2), then cap the open fitting immediately to keep moisture out of the system.
4. Remove the rubber (3) and disconnect the low pressure pipe (4), then cap the open fittings immediately to keep moisture out of the system.
5. Pull out the pressure pipes (2) and (4) from the bottom of the cabin.
6. Take out the pressure pipes (2) and (4).

**(When reassembling)**

- Replace the rubber (3) with a new one.
- Apply compressor oil (**NIPPONDENSO ND-OIL8** or equivalent) to the O-rings and take care not to damage them.

Tightening torque	High pressure pipe 2 retaining nut	11.8 to 14.7 N·m 1.2 to 1.5 kgf·m 8.7 to 10.8 ft-lbs
	Low pressure pipe retaining nut	29.5 to 34.3 N·m 3.0 to 3.5 kgf·m 21.7 to 25.3 ft-lbs

- (1) Pressure Switch (3) Rubber  
 (2) High Pressure Pipe 2 (4) Low Pressure Pipe

12190S00900

**(3) Removing Heater Hoses**

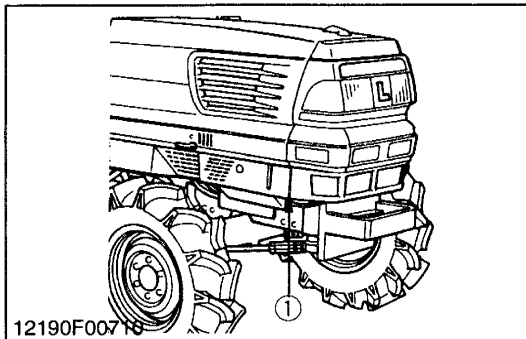

12190F00710

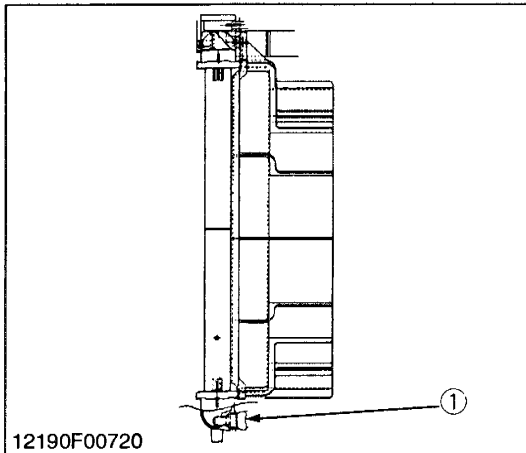

12190F00720

**Draining Coolant**

**CAUTION**

- **Never remove the radiator cap until coolant temperature is well below its boiling point. Then loosen cap slightly to relieve any excess pressure before removing cap completely.**

1. Stop the engine and let it cool down.
2. Remove the drain plug (1) or disconnect the hose to drain the coolant. When removing the drain plug, set the hose to drain port.
3. Remove the radiator cap to completely drain the coolant.
4. After all coolant is drained, reinstall the drain plug (1).

Coolant	Capacity	8.7 L 9.2 U.S.qts. 7.7 Imp.qts.
---------	----------	---------------------------------------

- (1) Drain Plug

12190S00380

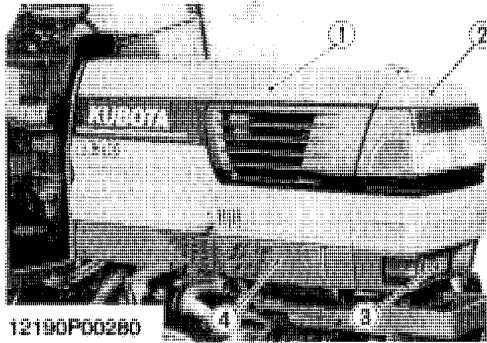

12190P00280

**Preparation 1**

1. Remove the side cover RH (1) and front mask (2).
2. Remove the front grille (3) and side skirt RH (4).

- |                     |                     |
|---------------------|---------------------|
| (1) Side Cover (RH) | (3) Front Grille    |
| (2) Front Mask      | (4) Side Skirt (RH) |

12190S00920

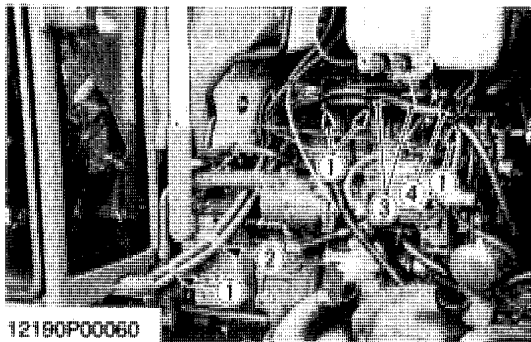

12190P00060

**Preparation 2**

1. Remove the hose bands (1).
2. Remove the hose stay (2).
3. Disconnect the heater hoses (3), then take out them under the cabin.

**(When reassembling)**

- In assembling the heater hoses (3) to the bypass pipe (4), connect the heater hose with identification mark (white paint) to upper side of the water valve.

- |               |                  |
|---------------|------------------|
| (1) Hose Band | (3) Heater Hoses |
| (2) Hose Stay | (4) Bypass Pipe  |

12190S00930

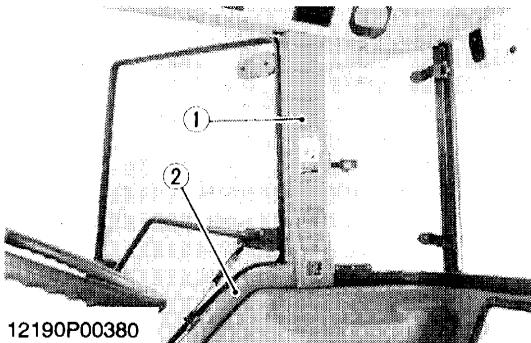

12190P00380

**Inner Covers**

1. Remove the inner covers (1) and (2).

- |                         |                         |
|-------------------------|-------------------------|
| (1) Inner Cover (Upper) | (2) Inner Cover (Lower) |
|-------------------------|-------------------------|

12190S00940

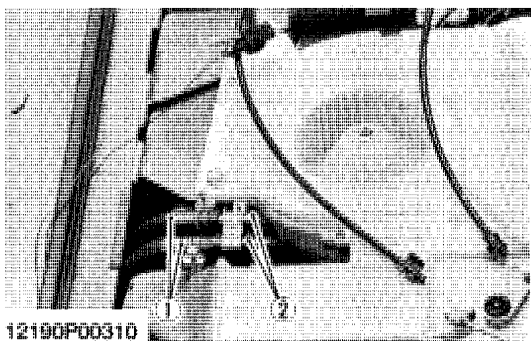

12190P00310

**Removing Heater Hoses**

1. Remove the outer roof.
2. Disconnect the heater hoses (1) from the hose pipes (2).
3. Pull out the heater hoses (1) from the bottom of the cabin.
4. Take out the heater hoses (1).

**(When reassembling)**

- In assembling the heater hose (1) to the pipe (2), connect the heater hose with identification mark (white paint) to upper side of the hose pipe.
- When connecting the heater hose with A/C unit, hose should be put into the A/C unit pipe more than 30 mm (1.2 in.).

- |                 |                 |
|-----------------|-----------------|
| (1) Heater Hose | (2) Heater Pipe |
|-----------------|-----------------|

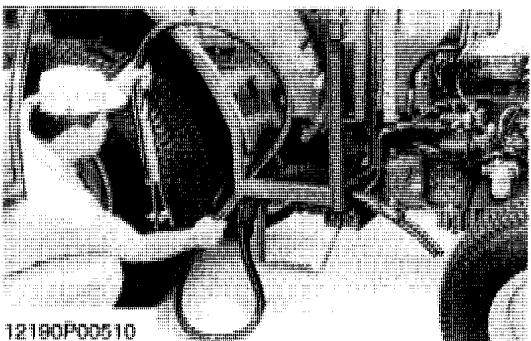

12190P00510

12190S00950

# SERVICING

## (1) Air Conditioner Unit

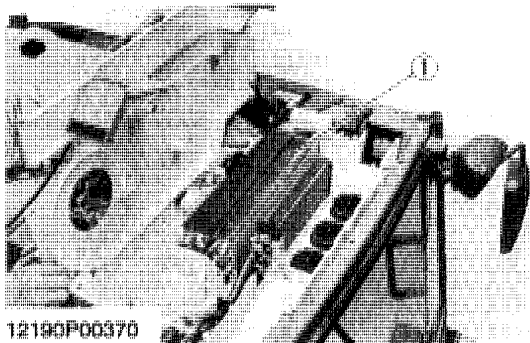

12190P00370

### Evaporator

1. Check whether white powder or dust is attached to the evaporator (1). If they are attached, wash them off with warm water and blow them off with compressed air.

### NOTE

- In case the evaporator is cleaned with warm water, cap the evaporator pipe ends so that water does not enter it.

- (1) Evaporator

12190S00960

## [4] LIGHTING SYSTEM CHECKING

### (1) Working Light

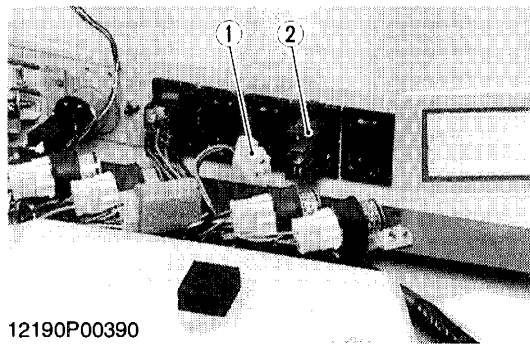

12190P00390

### Working Light Switch

1. Remove the outer roof, and disconnect the working light switch connector (1) from the switch (2) connector.
2. Perform the following checkings 1) and 2).

- (1) Working Light Switch Connector      (2) Working Light Switch

12190S00970

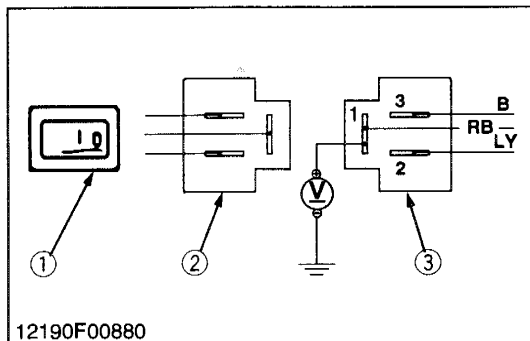

12190F00880

### 1) Connector Voltage

1. Turn the main switch **ON**.
2. Measure the voltage with a voltmeter across the connector 1 terminal and chassis.
3. If the voltage differs from the battery voltage, the wiring harness, fuse or main switch is faulty.

Voltage	1 terminal – Chassis	Approx. battery voltage
---------	----------------------	-------------------------

### 2) Working Light Switch

1. Check the continuity through the switch with an ohmmeter.
2. If continuity specified below is not indicated.

Position		Terminal		
		1	2	3
Working light switch	OFF		● (Ω)	●
	ON	●	● (Ω)	●

- (1) Working Light Switch  
 (2) Working Light Switch Connector (Switch Side)  
 (3) Working Light Switch Connector (Wiring Harness Side)

(a) From Main Switch AC Terminal

12190S00980

**(2) Hazard and Turn Signal Light**

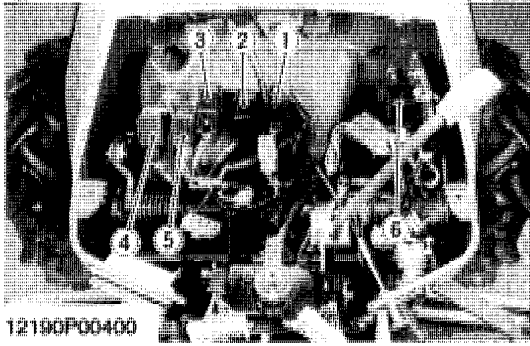

**Hazard and Turn Signal Relays**

1. Remove the panel under cover, and disconnect the relays (1), (2) and (3) connectors.
2. Perform the following checkings **1)** and **2)**.

- |                            |                   |
|----------------------------|-------------------|
| (1) Hazard Relay           | (4) Hazard Unit   |
| (2) Turn Signal Relay (LH) | (5) Starter Relay |
| (3) Turn Signal Relay (RH) | (6) Glow Relay    |

12190S00990

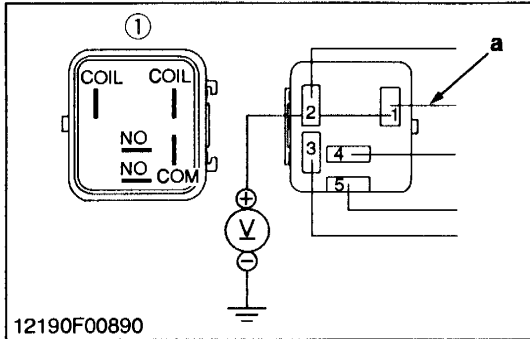

**1) Connector Voltage**

1. Turn the main switch **ON**.
2. Measure the voltage with a voltmeter across the connector **1** terminal and chassis.
3. If the voltage differs from the battery voltage, the wiring harness, fuse or main switch is faulty.

Voltage	1 terminal – Chassis	Approx; battery voltage
---------	----------------------	-------------------------

(1) Relay

(a) From Main Switch AC Terminal

12190S01000

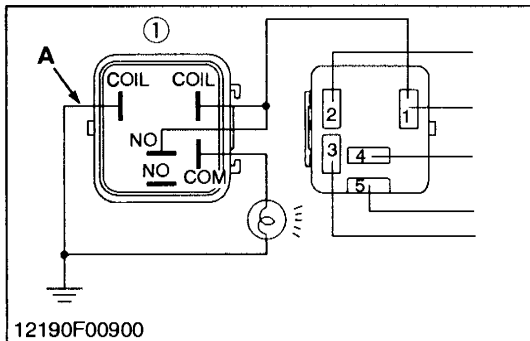

**2) Relay Test**

1. Remove the relays.
2. Connect jumper leads across the **1** terminal of connector and **COIL** terminal of relay, and across the **1** terminal of connector and **NO** terminal of relay.
3. Connect jumper leads across the **COIL** terminal of relay and chassis, and across the **COM** terminal of relay and **bulb** terminal.
4. Connect jumper leads across the **bulb** terminal and chassis, then main switch **ON** and light up the bulb.
5. If the bulb lights off when disconnecting the jumper lead **(A)** from the **COIL** terminal of relay, the relay is proper.

(1) Relay

12190S01010

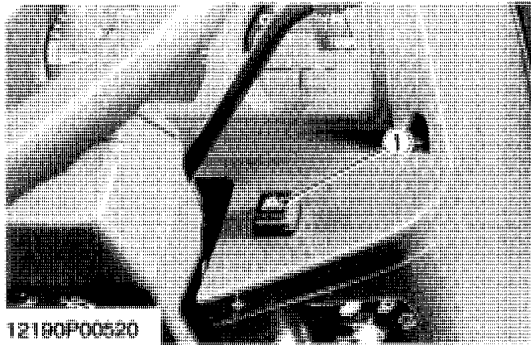

**Hazard Switch**

1. Remove the meter panel and remove the hazard switch (1).
2. Check the continuity through the switch with an ohmmeter.
3. If the continuity specified below is not indicated, the switch is faulty.

Position \ Terminal		A	B	C	D	E
		Hazard switch	OFF		●—●	
Hazard switch	ON	●—●		●—●		●—●

(1) Hazard Switch

(2) Bulb

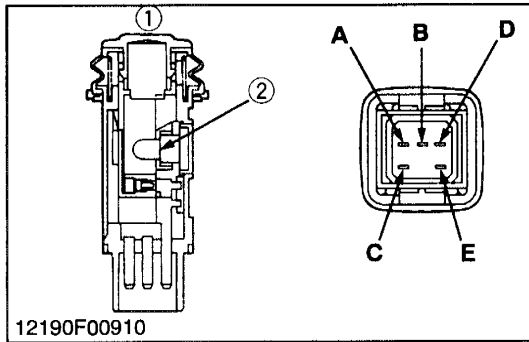

12190S01020

**[5] OTHERS  
DISASSEMBLING AND ASSEMBLING**

**(1) Cab Windshields**

**Preparation**

1. Prepare the followings.

1.1) Tools

- Cutter knife 1 pcs
- Scraper 1 pcs
- Gun for coating 1 pcs
- L shaped cutter 1 pcs
- Spoon for correction 1 pcs
- Sun grip (Suction rubber cup) 1 pcs
- Masking tape

1.2)

- \*1 Primer 35 and 47 or equivalent
- \*1 Bond U90 or equivalent
- \*2 PANDO524A Silicon or equivalent

**NOTE**

- \*1 is made by Sunrise MSI, Ltd.
- \*2 is made by Pando, Ltd.
- These materials (\*1 and \*2 Primer, Bond, Silicon) can't be provided by Kubota Corporation.
- Specially, Primer can't be stocked in a distributor for more than 60 days. Because it may set if a distributor keeps in stock for more than 60 days.
- Therefore, please find the local made equivalent materials in your country and use them when you need.

12190S01030

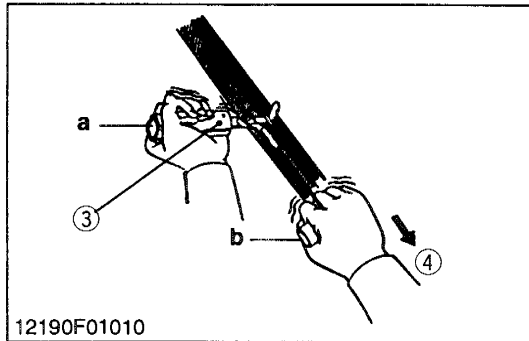
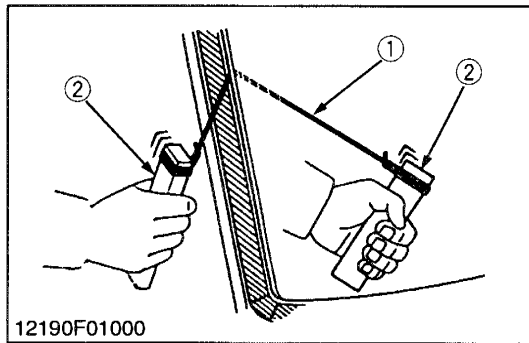

### **Before Replacing Windshields (1)**

#### **[In case of using piano wire (When glass is cracked)]**

1. Thread the piano wire from the inside of cabin. Tie its both ends to a wooden blocks or the like. (See the left figure.)
2. Pull the piano wire inward/outward alternately to cut the adhered part.

#### **NOTE**

- Do not let the piano wire make sliding contact with the edge of glass plate forcibly.

#### **[In case of using cutter knife (When glass is totally crushed finely)]**

1. Insert the knife (3) into the adhered part.
2. Keep the edge of knife blade square to the glass edge at the part (a). Slide the knife blade along the glass surface and the edge. Pull the part (b) in the direction parallel to the glass edge to cut them off.

#### **NOTE**

- Find a wider gap between the glass and body.
- Take care of handling the cutter knife not to damage your hand.

- |                |                  |
|----------------|------------------|
| (1) Piano Wire | (3) Cutter Knife |
| (2) Wood Piece | (4) Pulling      |

12190S01040

### **Before Replacing Windshields (2)**

1. When the bond U90 or equivalent attached to the cabin frame and the glass are reused, remove the bond clearly.
2. Clean the frame surface with ethyl acetate (or white gasoline, alcohol).
3. When the coating fell off vividly at the step 1 above, apply the primer 35 or equivalent to the cabin frame so that the bond can be applied evenly (resulting in better adhesion of U90).

#### **NOTE**

- Remove the bond completely.
- When the coating has fallen off, never use spray coating (or it may result in adhesive failure).
- The ethyl acetate is dangerous when it touches your eye (s). Attach a waste to its bottle opening to make ethyl acetate to penetrate it.

12190S01050



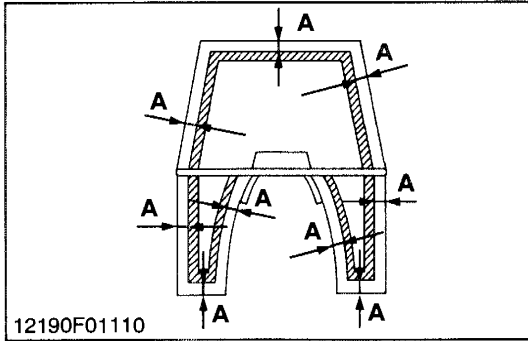
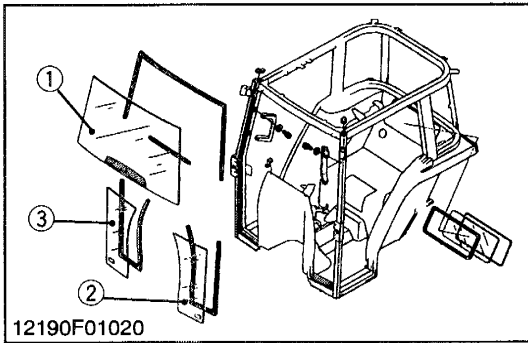

**Before Replacing Windshields (3)**

1. Check that the glasses are not damaged and cracked.
2. Turn over the glass and clean this rear surface of the glass by the waste which makes ethyl acetats and etc. to penetrate. This cleaning area of the rear surface is indicated "A" in the left figure.

■ **NOTE**

- **Checking method of face and rear surface of glass is as follows.**

- a) In the face surface side of upper windshield (1), the letters are indicated at the right upper side of it.
- b) Right lower windshield (3) is the same as left lower windshield (2).

From the view of out side, the normal letters are indicated in the left lower sindshield (2), but the reverse letters are indicated in the right lower front glass (3).

- If no cleaning the glass, it may result in adhesive failure.
- Take care of handling the ethyl acetate not to touch your eyes and etc. Attach a waste to its bottle opening to make ethyl acetate to penetrate it.

- |                              |                     |
|------------------------------|---------------------|
| (1) Upper Windshield         | A : 25 mm (1.0 in.) |
| (2) Lower Windshield (Left)  |                     |
| (3) Lower Windshield (Right) |                     |

12190S01060

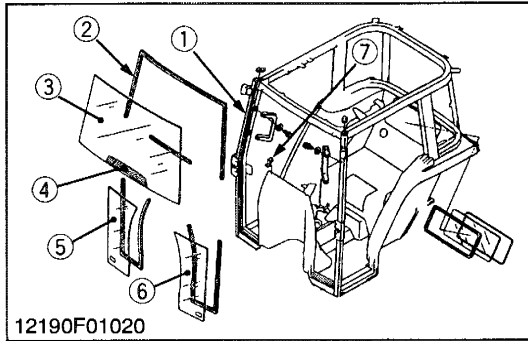

**Windshields Label**

1. Attach a label (4) on the new windshield (3) (T0270-70570).

■ **NOTE**

- **Remove the parts which may disturb your work, such as an outer roof, working lamp, and wiper before the work.**

- |                      |                              |
|----------------------|------------------------------|
| (1) Cabin Frame      | (5) Lower Windshield (Right) |
| (2) Shield Dam       | (6) Lower Windshield (Left)  |
| (3) Upper Windshield | (7) Windshield Stay          |
| (4) Label            |                              |

12190S01070

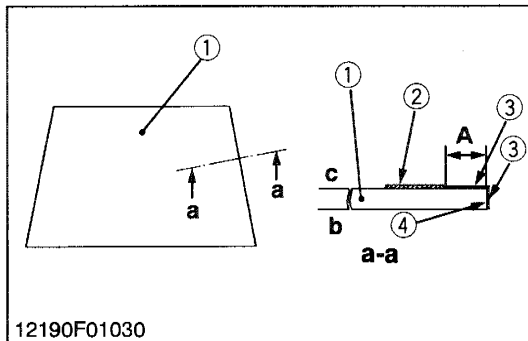

**Masking**

1. Attach a masking tape (2) (for a primer) 20 mm (0.8 in.) from the glass edge (4) (press it firmly to fix).

- |                  |                     |
|------------------|---------------------|
| (1) Windshield   | a-a : Cut Section   |
| (2) Masking Tape | b : Face Surface    |
| (3) Primer       | c : Rear Surface    |
| (4) Glass Edge   |                     |
|                  | A : 20 mm (0.8 in.) |

12190S01080

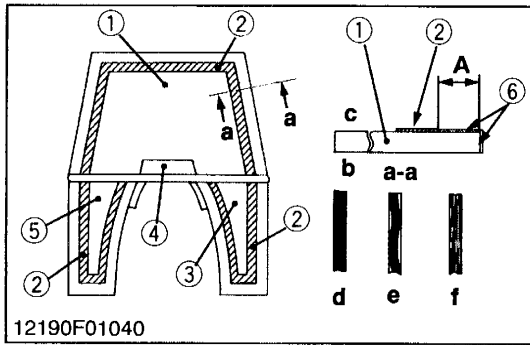

**Coating with Primer**

1. Coat the new glass with a primer (6) or equivalent) (\* on the rear surface and three sides of glass).
2. Apply a primer on the edge of glass (with a sponge or brush), too.

**NOTE**

- Rectify the primer coat if there appear deformation (curve) and stripes (unevenness) as shown in the left figure.

- |                              |                            |
|------------------------------|----------------------------|
| (1) Upper Windshield         | a-a : Cross Section        |
| (2) Masking Tape             | b : Face Surface           |
| (3) Lower Windshield (Right) | c : Rear Surface           |
| (4) Label                    | d : Correct Coating        |
| (5) Lower Windshield (Left)  | e : Incorrect (Curve)      |
| (6) Primer                   | f : Incorrect (Unevenness) |
|                              | A : 20 mm (0.8 in.)        |

12190S01090

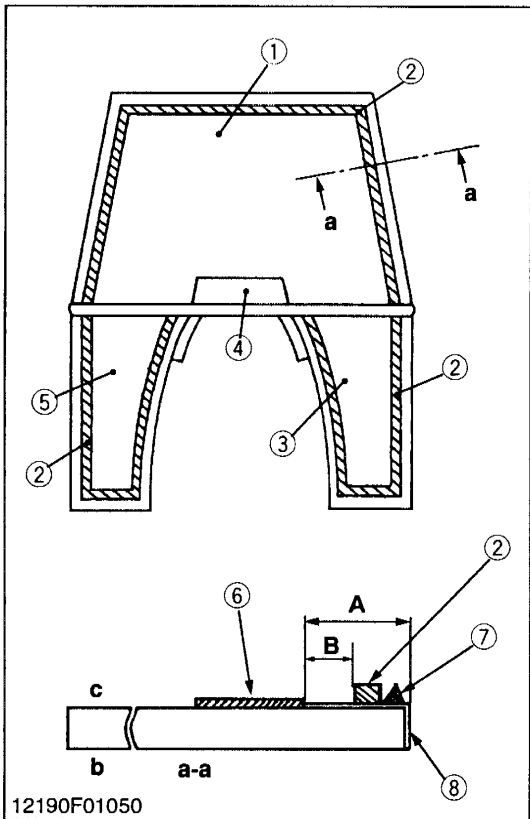

**Attaching Dam**

1. Attach a dam (2) (34070-99451 shield a'ssy dam) on the glasses (upper and lower windshield) (1), (3), (5).

**NOTE**

- Attach the dam 10 mm (0.4 in.) from the inside edge of primer applied surface as shown in the left figure.
- Attach the dam in place referring to the left figure.

2. Apply the bond U90 (7), or equivalent along the dam of glass (bonding).

**NOTE**

- Apply the bond U90 with the jig having the specified tip shape along the dam attached parts as shown in the left lower figure.
- Apply it with a uniform speed to minimize unevenness.

- |                              |                         |
|------------------------------|-------------------------|
| (1) Upper Windshield         | a-a : Cross Section     |
| (2) Dam                      | b : Face Surface        |
| (3) Lower Windshield (Right) | c : Rear Surface        |
| (4) Label                    |                         |
| (5) Lower Windshield (Left)  | A : 20 mm (0.8 in.)     |
| (6) Masking Tape             | B : 10 mm (0.4 in.)     |
| (7) Bond U90                 | E : Dia. 5 mm (0.2 in.) |
| (8) Primer                   | F : 10 mm (0.39 in.)    |
| (9) Jig                      |                         |

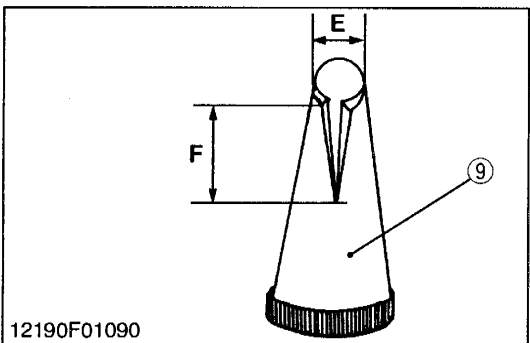

12190S01100

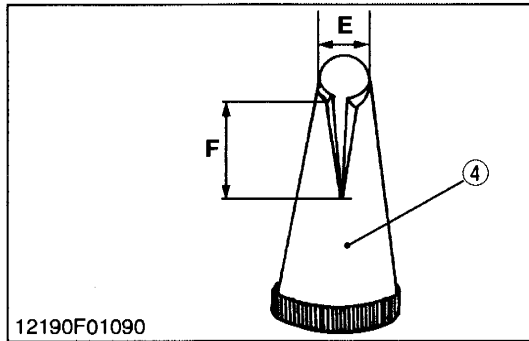
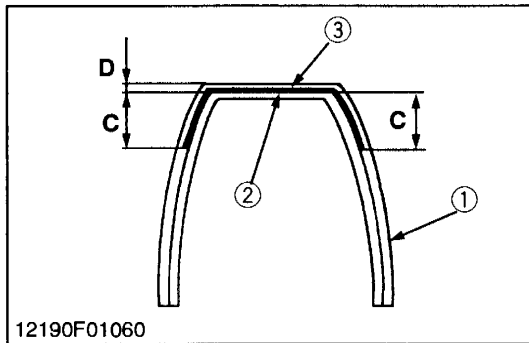

**Cabin Body Side**

1. Attach the dam (3) on the cabin body (1) side as shown in the left figure.

■ **NOTE**

- Attach the dam on the panel frame unit as shown in the left figure.
- Attach the dam of equal length, 70 to 80 mm (2.8 to 3.1 in.) on both sides as shown in the left figure.

2. Apply the bond U90 or equivalent along the dam on the cabin body side as shown in the left figure.

■ **NOTE**

- Apply the bond U90 along the dam with the jig (4) having the specified tip shape for the U90.
- Apply the bond with a uniform speed to minimize unevenness.

- |  |                                  |
|--|----------------------------------|
| (1) Cabin Body                                     | C : 70 to 80 mm (2.8 to 3.1 in.) |
| (2) Bond   | D : 2 to 3 mm (0.08 to 0.12 in.) |
| (3) Dam  | E : Dia. 5 mm (0.2 in.)          |
| (4) Jig (The Specified Tip Shape for the Bond U90) | F : 10 mm (0.39 in.)             |

12190S01120

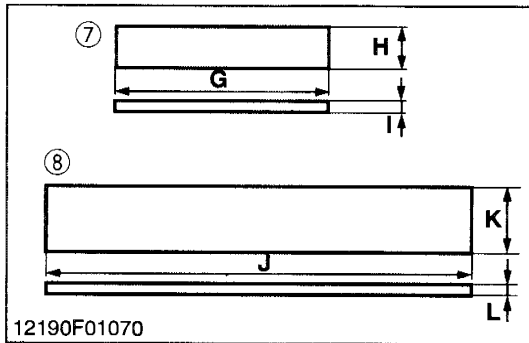
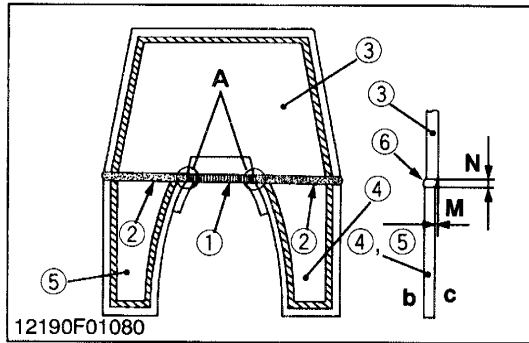

### Installing Windshield

1. Install the lower (left or right) windshield (5), (4) to the cabin with a sun grip (suction rubber cup) and fix it with a gummed tape. Leave it for five hours.

#### NOTE

- Use a jig A (7) shown in the left figure to create even clearance (5 mm (0.2 in.) approx.) between the lower windshield and cabin frame.
  - When the glass is set to the cabin frame with the fixing jig A (7), confirm that the whole clearance is even. When the glass is fixed, it is concave 5 mm (0.2 in.) approx. from the frame.
2. Set the upper windshield (3) to the cabin with the sun grip and fix it with a gummed tape.

#### NOTE

- Use a jig B (8) shown in the left figure to create even clearance (3 mm (0.12 in.) approx.) between the upper and lower windshield.
- When the glass is set with the fixing jig, confirm that the whole clearance is even. After the glass is fixed, it is concave 5 mm (0.2 in.) approx. from the frame.
- The level unevenness between the upper and lower windshields should be  $\pm 1$  mm ( $\pm 0.04$  in.) or less at the glass surface.
- The ethyl acetate is dangerous when it touches your eye (s). Attach a waste to its bottle opening to make ethyl acetate to penetrate it.

- (1) Bond U90  
 (2) PANDO524A Silicon  
 (3) Upper Windshield  
 (4) Lower Windshield (Left)  
 (5) Lower Windshield (Right)  
 (6) Protrusion for the Sake of Appearance  
 (7) Jig A  
 (8) Jlg B

b : Face Surface  
 c : Rear Surface

M : - 1 to 1 mm (- 0.04 to 0.04 in.)  
 N : 3 mm (0.12 in.)  
 G : 100 mm (3.9 in.)  
 H : 20 mm (0.8 in.)  
 I : 5 mm (0.2 in.)  
 J : 200 mm (7.9 in.)  
 K : 30 mm (1.2 in.)  
 L : 3 mm (0.12 in.)

12190S01130

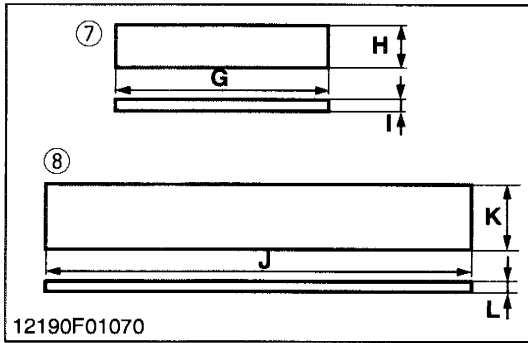
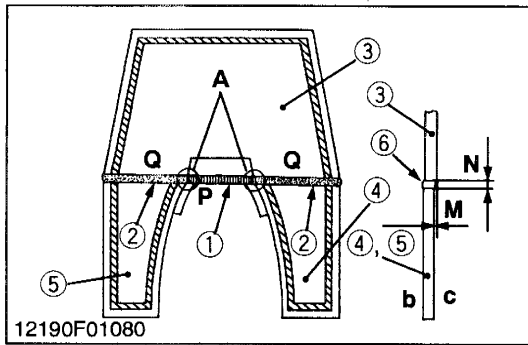

**Installing Windshield (Continued)**

4. Apply the bond U90 or equivalent to **P** part, PAN00524A silicon to **Q** part as shown in the left figure. Then rectify them with a spoon jig (**P** part) and a thin plate (**Q** part).

**NOTE**

- The part **A** shown in the left figure should be finished smoothly without any hollows of bond U90.
  - The finishing procedure of **Q** part silicon.
- I. Inject silicon to the both edges of the glass center (top points).

II. Attach a thin resin plate to the **Q** part from the inside of cabinet and inject silicon from the outside.

III. Use a thin resin plate to finish the outside surface and the inside surface in this order as shown in the left figure.

- Spread silicon equally.
- Do not mix air into silicon.
- Do not adhere silicon on the glass surface.
- Apply the primer 47 or equivalent to the bond U90 part for a better adhesive strength.
- The clearance between the front frame and the lower glass should be even on the right and left sides. The glass should not be tilted.

5. When the bond and silicon are dried well, remove the fixing gummed tape.

**NOTE**

- When the gummed tape is removed, the glass may be displaced. In this case fix it again.
- Remove the gummed tape little by little to confirm the bonding condition.

6. Check all the parts again.

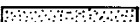
- |   |   |
|---|---|
| (1) Bond U90                              | M : - 1 to 1 mm (- 0.04 to 0.04 in.)  |
| (2) PAN00524A Silicon                     | N : 3 mm (0.12 in.)   |
| (3) Upper Windshield                      | G : 100 mm (3.9 in.)  |
| (4) Lower Windshield (Left)               | H : 20 mm (0.8 in.)   |
| (5) Lower Windshield (Right)              | I : 5 mm (0.2 in.)  |
| (6) Protrusion for the Sake of Appearance | J : 200 mm (7.9 in.)  |
| (7) Jig A                                 | K : 30 mm (1.2 in.)   |
| (8) Jlg B                                 | L : 3 mm (0.12 in.)   |
|   | P :  |
|   | Q :  |

**b : Face Surface**  
**c : Rear Surface**

12190S01140



## SPECIFICATIONS

Model		RC72-29A	RC72-36A
Suitable tractors		L3010, L3410	L3710, L3710 CABIN
Mounting method		Pantograph linkage	
Adjustment of cutting height		Gauge wheel	
Cutting height		38 to 115 mm (1.5 to 4.5 in.)	
Cutting width		1826 mm (72 in.)	
Weight (Approx.)		216 kg (476 lbs)	
Blade spindle speed		41.8 r/s (2509 rpm)	
Blade tip velocity		82.1 m/s (16160 fpm)	
Blade length		625 mm (24.6 in.)	
Number of blades		3	
Dimensions	Total length	1210 mm (47.6 in.)	
	Total width	2250 mm (88.6 in.)	
	Total height	430 mm (16.9 in.)	

# EXTERIOR VIEW AND APPLICATION

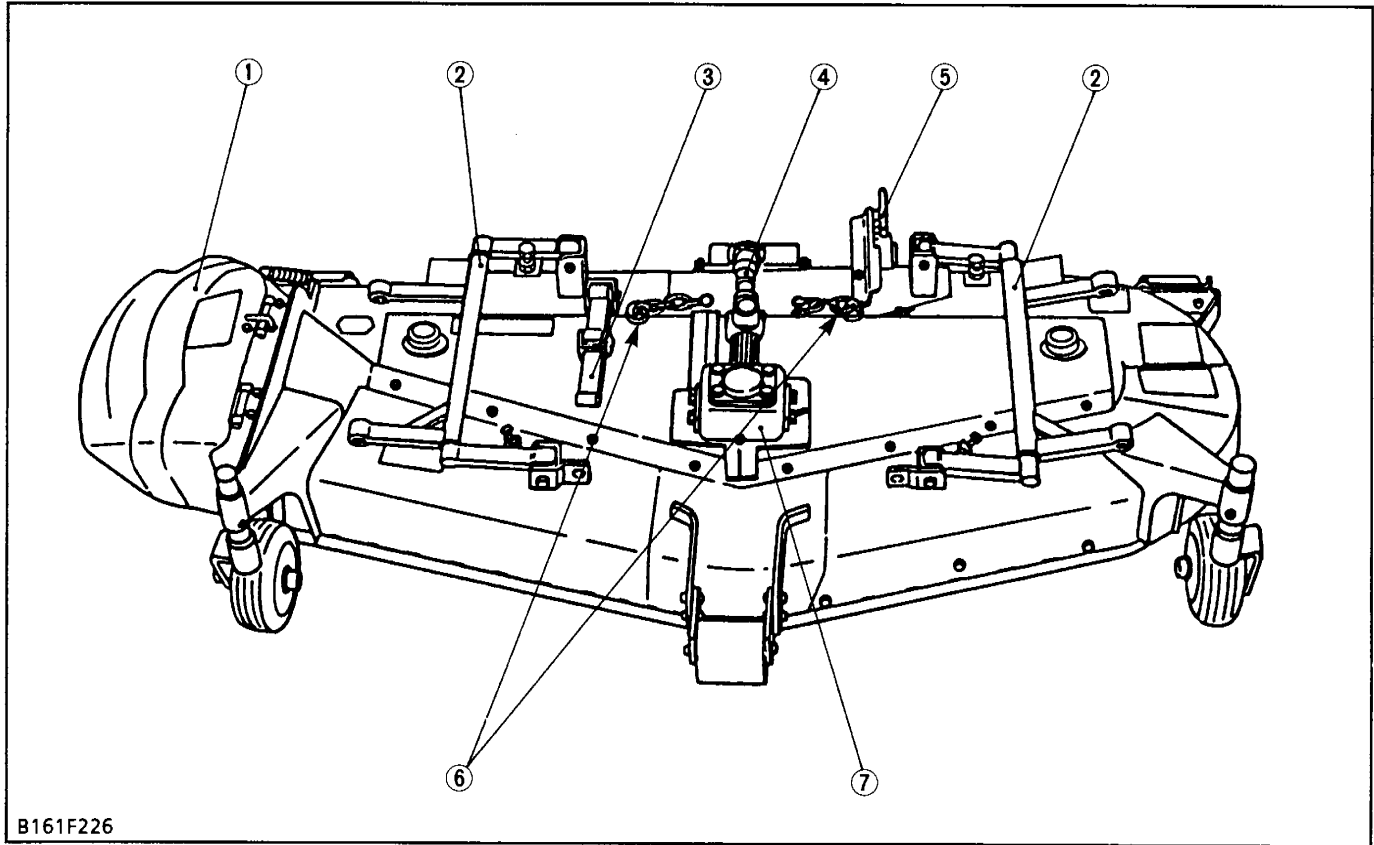

B161F226

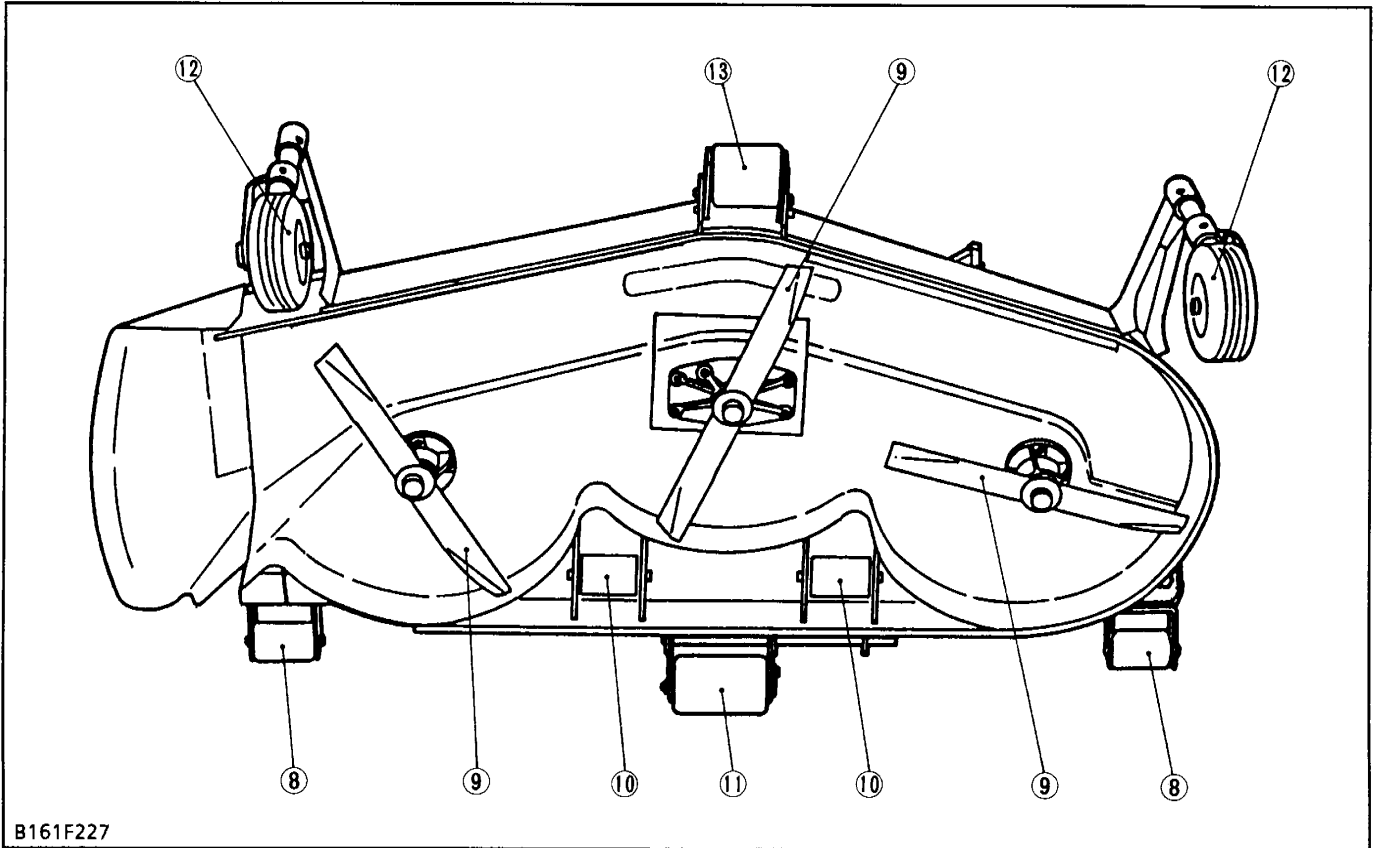

B161F227

- |                        |                   |                                |                              |
|------------------------|-------------------|--------------------------------|------------------------------|
| (1) Discharge Chute    | (5) Control Lever | (8) Rear Anti-scalp Rollers    | (11) Rear Gauge Wheel        |
| (2) Pantograph Linkage | (6) Lift Chains   | (9) Blades                     | (12) Front Gauge Wheels      |
| (3) Link 1             | (7) Gear Box      | (10) Center Anti-scalp Rollers | (13) Front Anti-scalp Roller |
| (4) Universal Joint    |                   |                                |                              |



# MECHANISM

## CONTENTS

[1] POWER TRANSMISSION ..... M-M1  
[2] LIFTING MECHANISM ..... M-M2



## [1] POWER TRANSMISSION

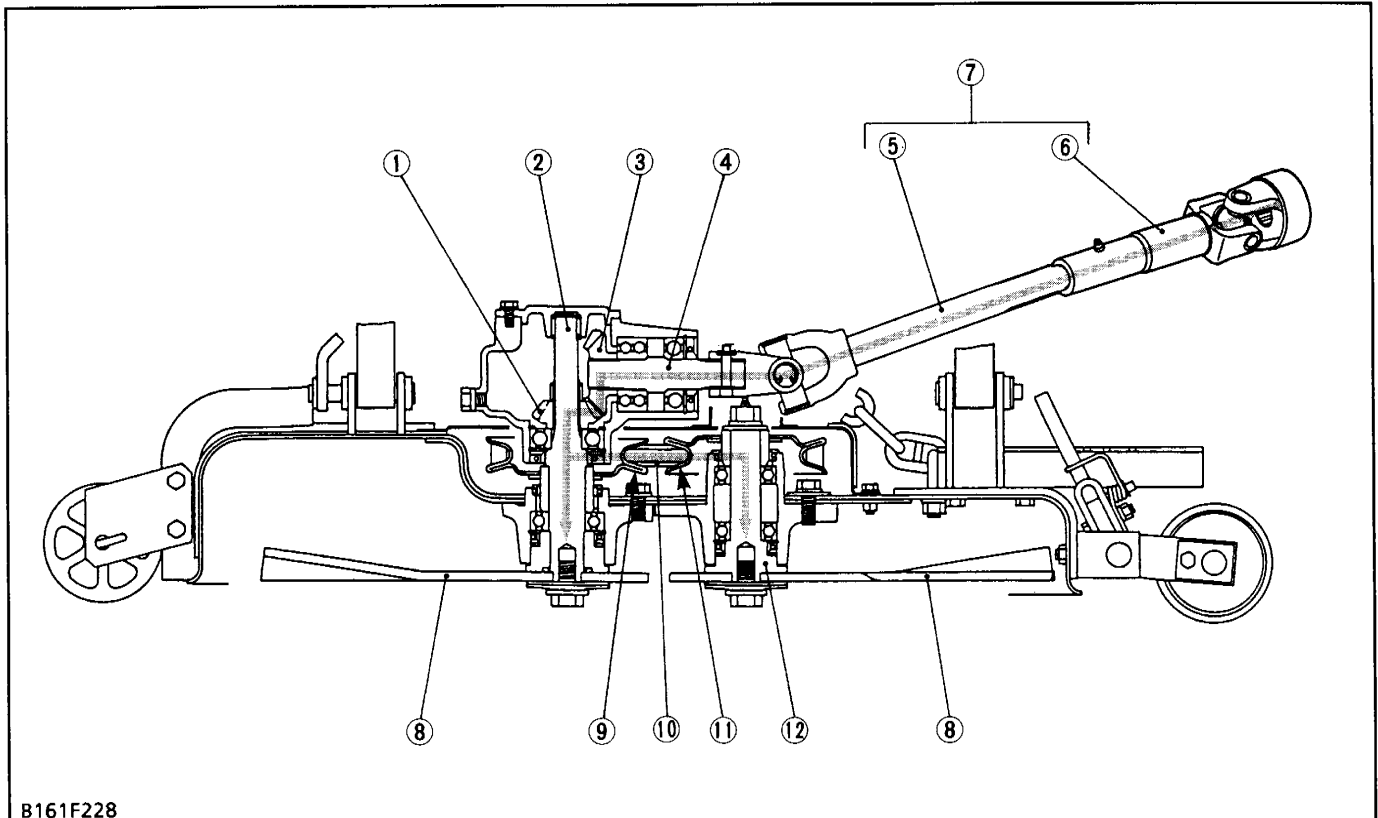

B161F228

(1) 17T Bevel Gear  
 (2) Spindle Shaft  
 (3) 20T Bevel Gear

(4) Pinion Shaft  
 (5) Shaft Yoke  
 (6) Spline Yoke

(7) Universal Joint  
 (8) Blades  
 (9) Pulley 1

(10) V-belt  
 (11) Pulley 2  
 (12) Cutter Shaft

When the PTO shift lever and mid PTO lever are shifted to "ENGAGE" positions, the power is transmitted from mid PTO to blades (8) as follows :

Mid PTO → Universal Joint (7) → Pinion Shaft (4) → 20T Bevel Gear (3) → 17T Bevel Gear (1) → Spindle Shaft (2) → (Pulley 1 (9) → V-belt (10) → Pulley 2 (11) → Cutter Shaft (12)) → Blades (8).

### (Reference)

- Keep the engine running at full throttle for best results.

## [2] LIFTING MECHANISM

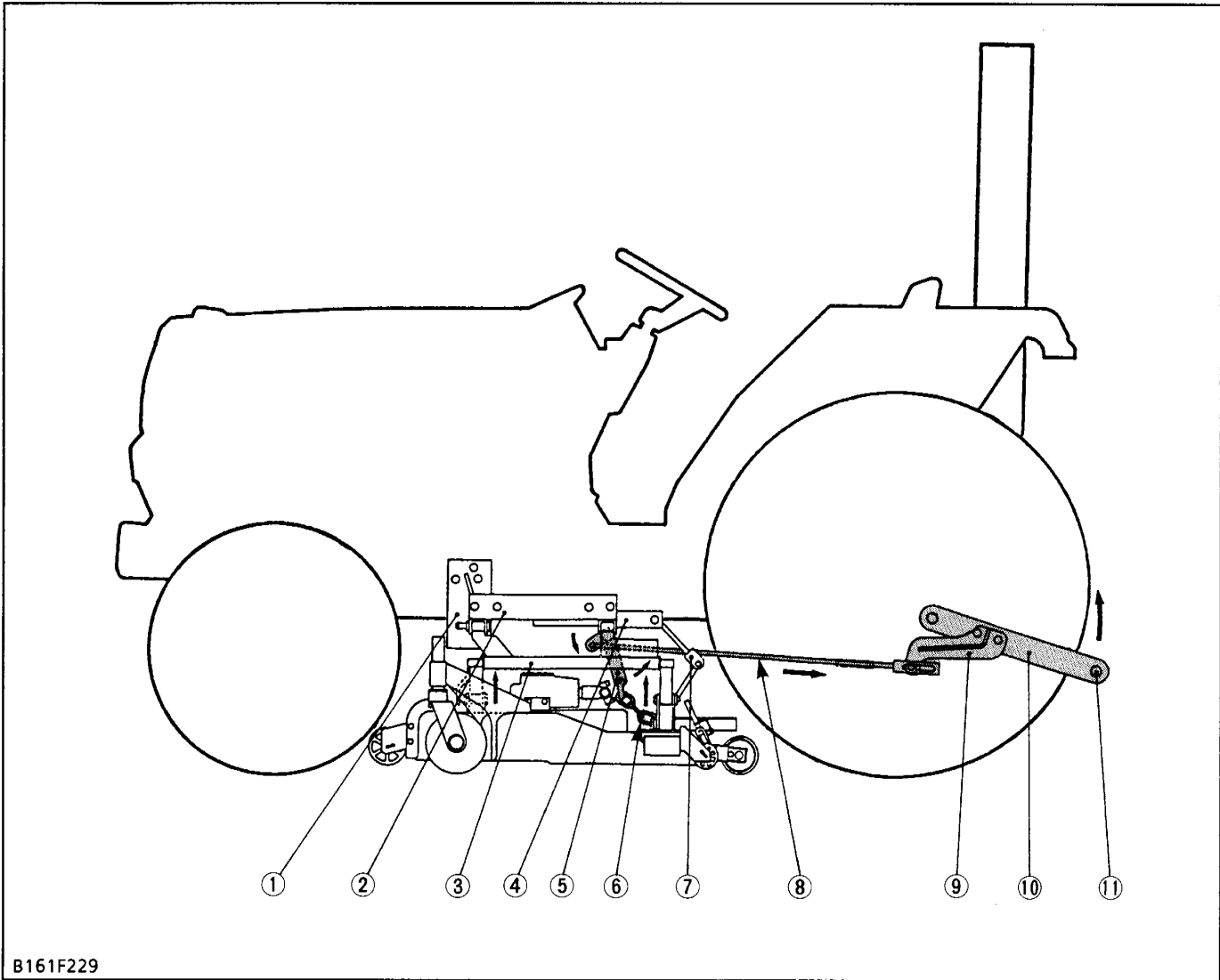

B161F229

- |                          |                         |                    |                   |
|--------------------------|-------------------------|--------------------|-------------------|
| (1) Front Hanger Bracket | (4) Rear Hanger Bracket | (7) Link 1         | (10) Lower Link   |
| (2) Side Frame           | (5) Lift Link           | (8) Connecting Rod | (11) Spreader Bar |
| (3) Upper Link           | (6) Lift Chain          | (9) Lift Bracket   |                   |

The lifting of mower is performed by the hydraulic system installed on the tractor.

For avoiding danger, the mower should be kept lifting when traveling. When the hydraulic position control lever is moved to the LIFT position, the lower link (10) is risen by the oil pressure of hydraulic system, and lift chain (6) is pulled by the connecting rod (8) and lift link (5).

Therefore, the mower is lifted.

As the upper link system is a pantographic linkage, the mower can be kept parallel at every position.

**⚠ CAUTION**

- Never operate mower in transport position.

# SERVICING

## CONTENTS

<b>GENERAL</b> .....	M-S1
<b>[1] MOWER IDENTIFICATION</b> .....	M-S1
<b>[2] GENERAL PRECAUTION</b> .....	M-S1
<b>[3] LUBRICANTS</b> .....	M-S2
<b>[4] TIGHTENING TORQUES (GENERAL USE SCREWS, BOLTS AND NUTS)</b> .....	M-S2
<b>[5] MAINTENANCE CHECK LIST</b> .....	M-S3
<b>[6] CHECK AND MAINTENANCE</b> .....	M-S3
<b>TROUBLESHOOTING</b> .....	M-S5
<b>SERVICING SPECIFICATIONS</b> .....	M-S5
<b>TIGHTENING TORQUES</b> .....	M-S5
<b>MOUNTING AND DISMOUNTING MOWER</b> .....	M-S6
<b>CHECKING, DISASSEMBLING AND SERVICING</b> .....	M-S7
<b>CHECKING AND ADJUSTING</b> .....	M-S7
<b>DISASSEMBLING AND ASSEMBLING</b> .....	M-S9
<b>SERVICING</b> .....	M-S11



# GENERAL

## [1] MOWER IDENTIFICATION

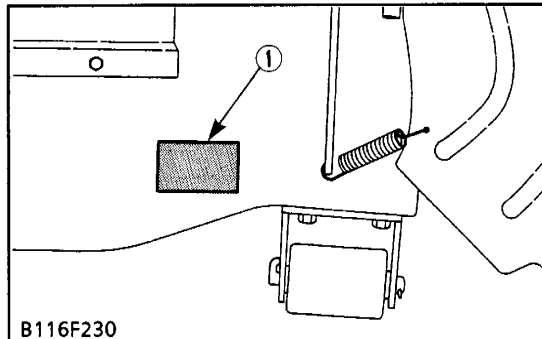

B116F230

When contacting KUBOTA, always specify mower serial number.

(1) Mower Serial Number

## [2] GENERAL PRECAUTION

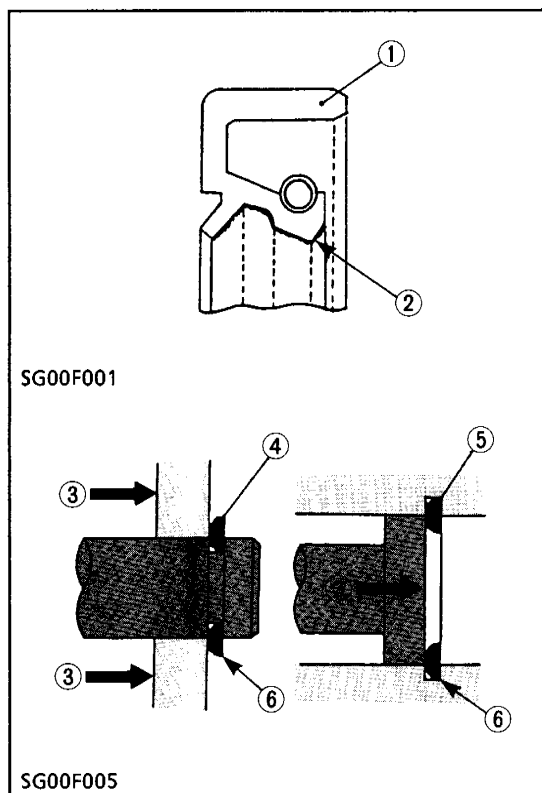

SG00F001

SG00F005

- During disassembly, carefully arrange removed parts in a clean area to prevent confusion later. Screws, bolts and nuts should be installed in their original position to prevent reassembly errors.
- When special tools are required, use KUBOTA genuine special tools. Special tools which are not frequently used should be made according to the drawings provided.
- Use KUBOTA genuine parts or KUBOTA - recommended parts and lubricants or their equivalents.
- Gaskets and O-rings must be replaced during reassembly.
- Apply grease to new O-rings or oil seals before assembling. See the figure.
- When reassembling external snap rings or internal snap rings. They must be positioned so that sharp edge faces against the direction from which a force is applied. See the figure.
- Use only metric tools when servicing this machine. Metric screws, bolts and nuts are not interchangeable with nonmetric fasteners.
- Remove oil and dirt from parts before measuring.



- |              |                        |
|--------------|------------------------|
| (1) Oil Seal | (4) External Snap Ring |
| (2) Grease   | (5) Internal Snap Ring |
| (3) Force    | (6) Sharp Edge         |

**[3] LUBRICANTS**

Place	Capacity	Lubricants
Gear box	0.75 ℓ 0.79 U.S.qts. 0.66 Imp.qts.	SAE 90 gear oil
Universal joint	Until grease overflows	SAE multi-purpose type grease
Front gauge wheel bracket	Until grease overflows	
Front and rear gauge wheels	Until grease overflows	
Three spindle shafts	Until grease overflows	
Belt tension pivot	Until grease overflows	
Tension pulley	Until grease overflows	

**[4] TIGHTENING TORQUES (GENERAL USE SCREWS, BOLTS AND NUTS)**

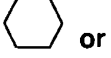
Screws, bolts and nuts whose tightening torques are not specified in this Workshop Manual should be tightened according to the table below.

Grade Unit Nominal Diameter	No-grade or 4T * (  or  )			7T * (  )		
	N·m	kgf·m	ft-lbs	N·m	kgf·m	ft-lbs
M 6	7.85 to 9.32	0.80 to 0.95	5.79 to 6.87	9.81 to 11.28	1.00 to 1.15	7.24 to 8.32
M 8	17.65 to 20.59	1.80 to 2.10	13.0 to 15.2	23.54 to 27.46	2.40 to 2.80	17.4 to 20.2
M10	39.23 to 45.11	4.00 to 4.60	29.0 to 33.2	48.05 to 55.90	4.90 to 5.70	35.5 to 41.2
M12	62.76 to 72.57	6.40 to 7.40	46.3 to 53.5	77.47 to 90.22	7.90 to 9.20	57.2 to 66.5
M14	107.9 to 125.5	11.0 to 12.8	79.6 to 92.5	123.6 to 147.1	12.6 to 15.0	91.2 to 108
M16	166.7 to 191.2	17.0 to 19.5	123 to 141	196.1 to 225.6	20.0 to 23.0	145 to 166
M18	245.2 to 284.4	25.0 to 29.0	181 to 210	274.6 to 318.7	28.0 to 32.5	203 to 235
M20	333.4 to 392.3	34.0 to 40.0	246 to 289	367.7 to 431.5	37.5 to 44.0	272 to 318

\* The figures on the table above are indicated the top of screw or bolt.



## [5] MAINTENANCE CHECK LIST

To keep the mower working in good condition as well as to avoid any accident and trouble, carry out periodic inspection and maintenance. Check the following points before use.

Service Interval	Check Points	Reference Page
Daily	<ul style="list-style-type: none"> <li>● Anything unusual in previous day's operation</li> <li>● Apply grease to belt tension pivot and belt tension pulley</li> <li>● Oil leakage</li> <li>● Make sure blade screws are tighten</li> <li>● Check wear of blade</li> <li>● Check all hardware</li> <li>● Make sure all pins are in place</li> <li>● Clean around the exhaust manifold and the muffler of the engine</li> <li>● Apply grease to internal splines and grease nipples of universal joint</li> <li>● Apply grease to three spindle shafts</li> </ul>	<p>—</p> <p>M-S4</p> <p>—</p> <p>M-S9</p> <p>M-S7</p> <p>—</p> <p>—</p> <p>—</p> <p>M-S4</p> <p>M-S4</p>
Initial 50 hours	<ul style="list-style-type: none"> <li>● Change gear box oil</li> </ul>	M-S3
Every 50 hours	<ul style="list-style-type: none"> <li>● Check oil level in gear box</li> <li>● Apply grease to wheels</li> <li>● Check belt tension</li> </ul>	<p>M-S3</p> <p>M-S4</p> <p>M-S8</p>
Every 150 hours	<ul style="list-style-type: none"> <li>● Change gear box oil</li> <li>● Clean mower deck beneath shield</li> </ul>	<p>M-S3</p> <p>M-S4</p>

## [6] CHECK AND MAINTENANCE

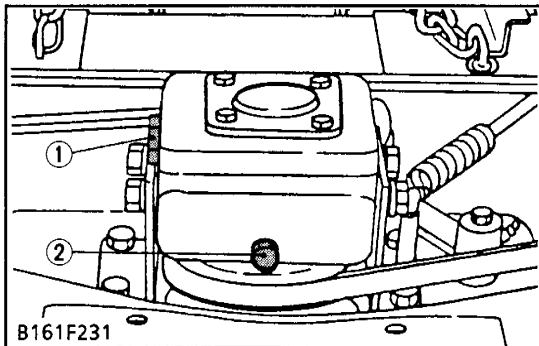

B161F231

### Checking Oil Level in Gear Box

1. Place the mower on level ground and loosen the check plug (1).
2. Check to see if oil seep from the opening.
3. If the oil level is below, add sufficient SAE 90 gear oil.

Capacity	Gear box oil	0.75 ℓ 0.79 U.S.qts. 0.66 Imp.qts.
----------	--------------	--

(1) Check Plug

(2) Drain Plug

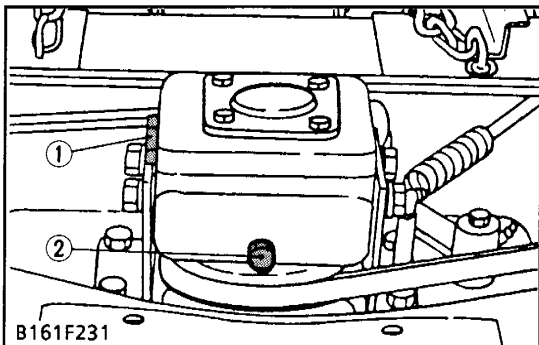

B161F231

### Changing Oil in Gear Box

1. Place the mower on level ground.
2. Remove the check plug (1) and drain plug (2), and then drain the oil.
3. Reinstall the drain plug (2), and then fill oil up to the specified level.
4. Reinstall the check plug (1).

Capacity	Gear box oil	0.75 ℓ 0.79 U.S.qts. 0.66 Imp.qts.
----------	--------------	--

(1) Check Plug

(2) Drain Plug

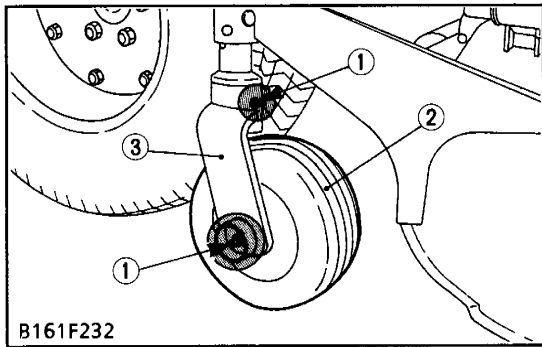

**Greasing Wheels**

1. Apply grease to the grease nipples (1), (5) of front gauge wheel brackets (3) and rear gauge wheel (4), if the amount of grease is insufficient.

- (1) Grease Nipple
- (2) Front Gauge Wheel
- (3) Front Gauge Wheel Bracket
- (4) Rear Gauge Wheel
- (5) Grease Nipple

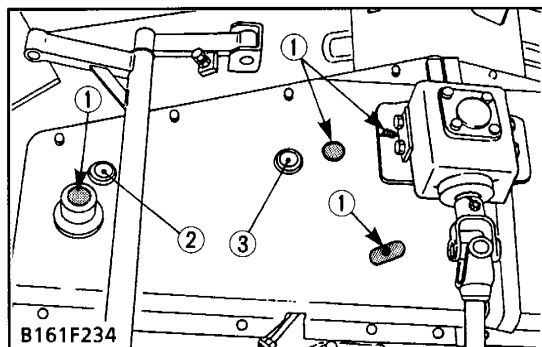
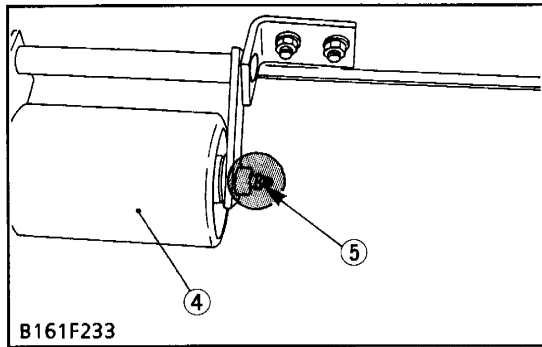

**Greasing Three Spindle Shaft, Belt Tension Pivot and Tension Pulley**

1. Remove the spindle cap (2) and belt tension pivot cap (3).
2. Apply grease to the grease nipples (1) of the spindle shafts, belt tension pivot, and tension pulley, if the amount of grease is insufficient.

- (1) Grease Nipple
- (2) Spindle Cap
- (3) Belt Tension Pivot Cap

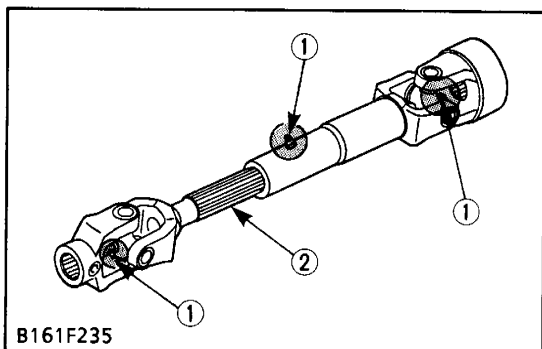

**Greasing Internal Splines and Grease Nipples of Universal Joint**

1. Apply grease to the internal splines (2) and grease nipples (1) of the universal joint, if the amount of grease is insufficient.

- (1) Grease Nipples
- (2) Spline

**Cleaning Mower Deck Beneath Shield**

1. Remove the shield.
2. Remove grass dippings, chaff and debris from the top of the mower deck.
3. Reinstall the shield.

## TROUBLESHOOTING

Symptom	Probable Cause	Solution	Reference Page
Blade Does Not Rotate	<ul style="list-style-type: none"> <li>Broken mower belt</li> </ul>	Replace mower belt	M-58
Blade Speed Is Slow	<ul style="list-style-type: none"> <li>Loosen mower belt</li> <li>Clogged grass</li> <li>Flattened out or worn cup washer</li> </ul>	Adjust belt tension or replace mower belt Remove grass Replace cup washer	M-58, S10 – M-59
Cutting Is Poor	<ul style="list-style-type: none"> <li>Worn or broken blade</li> <li>Loosen mower blade screw</li> <li>Cutting height improper</li> </ul>	Sharpen or replace blade Retighten blade screw Adjust cutting height	M-57, S9 M-59 –
Mower Is Not Lifted	<ul style="list-style-type: none"> <li>Trouble of hydraulic system (lift cylinder and control valve)</li> <li>Broken linkage system</li> </ul>	Check hydraulic system Replace linkage system	– –

## SERVICING SPECIFICATIONS

Item		Factory Specification	Allowable Limit
Bevel Gears	Backlash	0.13 to 0.25 mm 0.0051 to 0.0098 in.	–
	Turning Torque	Less than 0.69 N·m 0.07 kgf·m 0.51 ft·lbs	–
Tension Spring	Length	164 to 166 mm 6.45 to 6.53 in.	–
Stop Bolt (Front)	Length [RC72-29A]	13 to 15 mm, 0.51 to 0.59 in.	–
	[RC72-36A] ROPS	25 to 27 mm, 0.98 to 1.06 in.	–
	CABIN	31 to 33 mm, 1.22 to 1.30 in.	–
Stop Bolt (Rear)	Length [RC72-29A]	21 to 23 mm, 0.83 to 0.91 in.	–
	[RC72-36A] ROPS	17 to 19 mm, 0.67 to 0.75 in.	–
	CABIN	23 to 25 mm, 0.91 to 0.98 in.	–
Connecting Rod	Length	ROPS 899 to 901 mm 35.4 to 35.5 in.	–
		CABIN 904 to 906 mm 35.6 to 35.7 in.	–

## TIGHTENING TORQUES

Tightening torques of screws and nuts on the table below are especially specified.  
(For general use screws and nuts : See page M-52)

Item	N·m	kgf·m	ft·lbs
Blade screw	177 to 216	18 to 22	130 to 159

# MOUNTING AND DISMOUNTING MOWER

## ⚠ CAUTION

- When dismantling the mower, park the tractor on flat ground, apply the parking brake, and stop the engine.

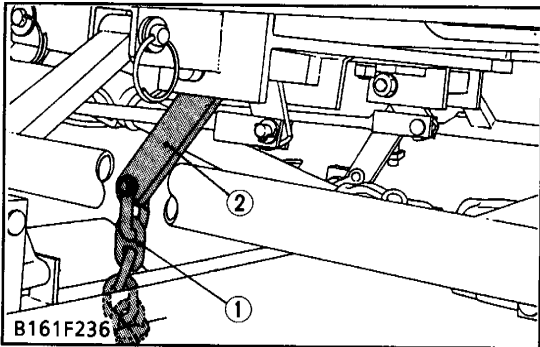

### Lift Chain

1. Remove the lift chains (1) from the lift link (2).

#### (When mounting)

- Be sure not to twist the lift chains (1).

- (1) Lift Chain (2) Lift Link

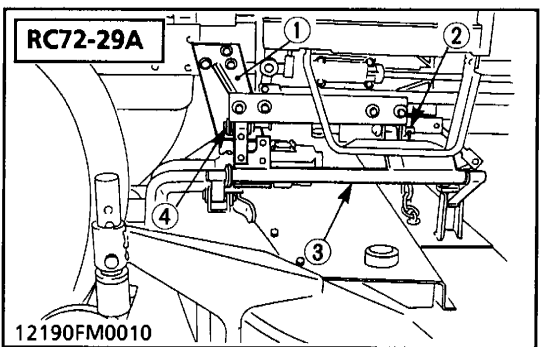

### Upper Links and Link 1

1. Remove the upper links (3) from the hanger brackets.

#### (When mounting)

- Install the upper link, noting its direction.

- (1) Hanger Bracket (2) Clevis Pin (A) (Ø14×75) (3) Upper Link (4) Clevis Pin (B) (Ø14×90)

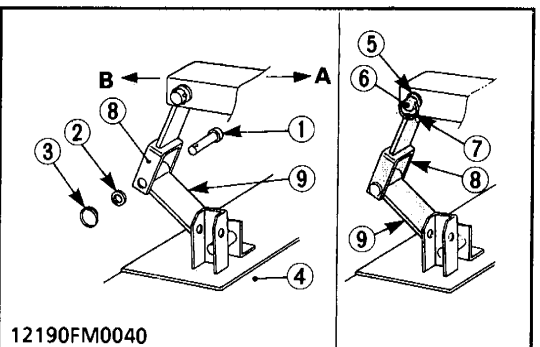
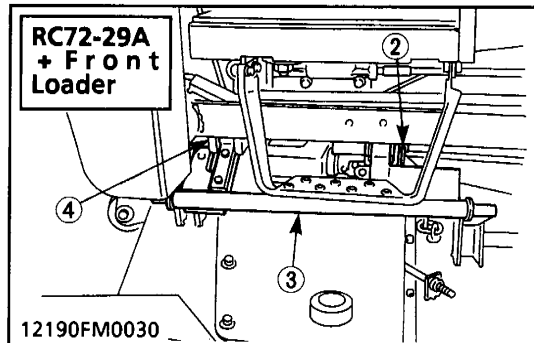
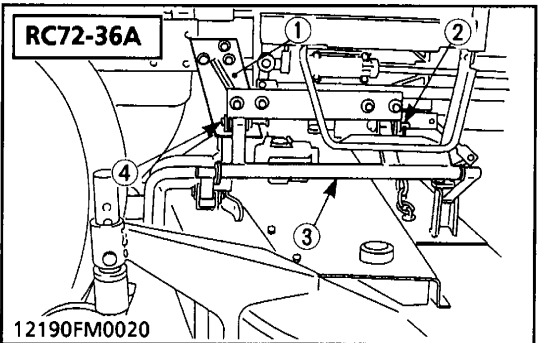

### Link 1

#### [HST Model]

1. Remove the clevis pin (1) and disconnect the link 1 (8) from the link 2 (9).

#### [Manual Transmission and GST Model]

1. Remove the clevis pin (6) and disconnect the link 1 (8) from the hanger bracket (10).

#### (When mounting)

- Install the upper link 1, noting its direction.

- (1) Clevis Pin (2) Plain Washer (3) Snap Ring (4) Mower Deck (5) Plain Washer (6) Clevis Pin (7) Snap Ring (8) Link 1 (9) Link 2 (10) Hanger Bracket

A: Front

B: Rear

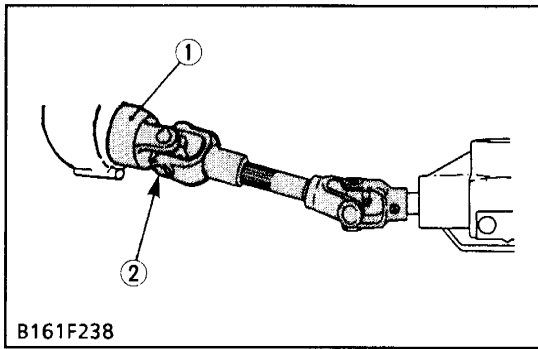

**Universal Joint**

1. Pull back the coupler (1) of the universal joint (2), and then remove it from mid PTO shaft.

**(When mounting)**

- Pull back the coupler (1) of the universal joint (2). Push the universal joint (2) onto the mid PTO shaft until the coupler locks. Slide the universal joint (2) back and forward to make sure the universal joint (2) is locked securely.

**IMPORTANT**

- Finally pull the universal joint to see if it is tight in position.

(1) Coupler

(2) Universal Joint

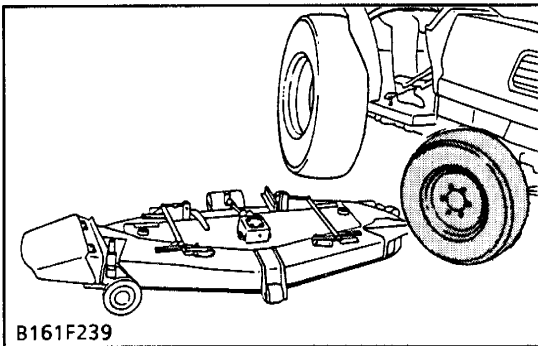

**Taking Out Mower**

1. Turn the front wheels to the left.
2. Take out the mower to the right side of the tractor.

**NOTE**

- To take out the mower easily, remove only the left front gauge wheel and attach the both rear anti-scalp rollers (1) as shown in the photograph.

(1) Rear Anti-scalp Roller

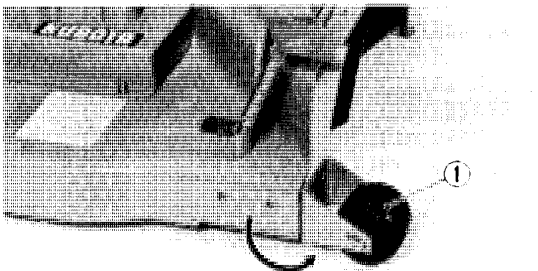

0329P204

**CHECKING, DISASSEMBLING AND SERVICING**

**CHECKING AND ADJUSTING**

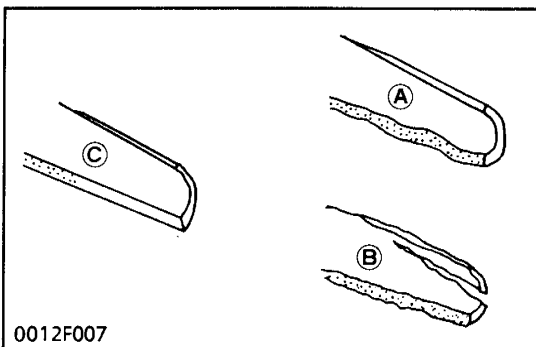

**Checking Blade**

1. Check the cutting edge of blade.
2. Sharpen the cutting edges, if the blades are as shown in figure (A). Replace the blades, if they are as shown in figure (B). (Refer to "DISASSEMBLING AND ASSEMBLING".)

**NOTE**

- To sharpen the blades by yourself, clamp the blade securely in a vise and use a large mill file along the original bevel. File to a sharp edge.
- To balance the blade, place a small rod through the center hole and check to see if the blade balances evenly. File heavy side of the blade until it balances out even.

0012F007

[A] Easy Blade Wear  
[B] Wear

[C] New Blade

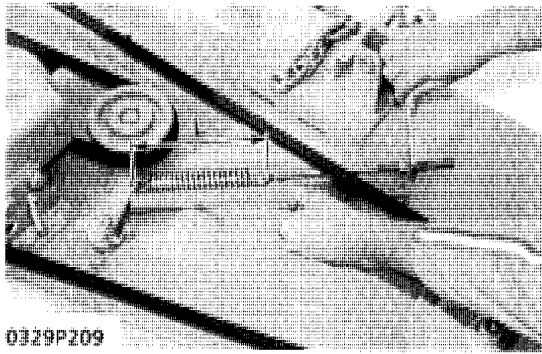

0329P209

**Adjusting Belt Tension**

1. Dismount the mower from the tractor, and remove the right and left shields from the mower deck.
2. Measure the length (L) of the tension spring.
3. If the measurement is not within the factory specifications, adjust the length with the tension screw.

Spring length	Factory spec.	164 to 166 mm 6.45 to 6.53 in.
---------------	---------------	-----------------------------------

**NOTE**

- After adjustment, secure the tension screw with the lock nut.

**Checking Belt**

1. Check to see the belt.
2. Replace the belt with a new one, if there is found surface split at more than 3 positions.

**(When replacing belt)**

1. Remove the right and left shields.
  2. Loosen the tension screw.
  3. Remove the right hand bracket (1) which mounts the gear box to the deck.
  4. Remove the belt.
- To install a new belt, reverse the above procedures.

**IMPORTANT**

- Before removing the right hand bracket (1), loosen the tension screw.
- After replacing the belt, be sure to adjust the belt tension.

(1) Right Hand Bracket

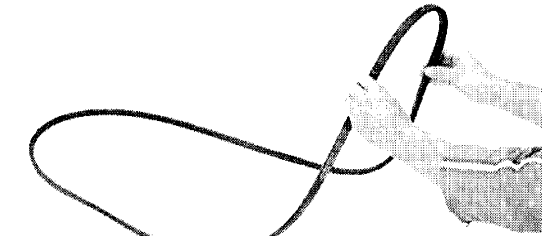

0012P029

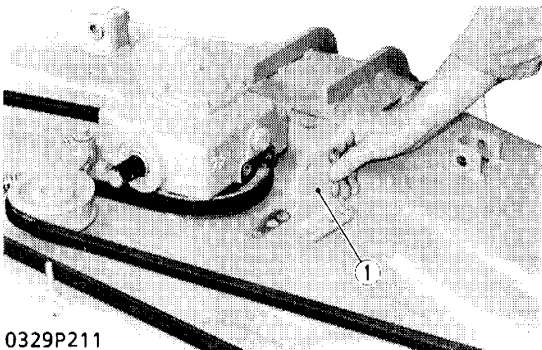

0329P211

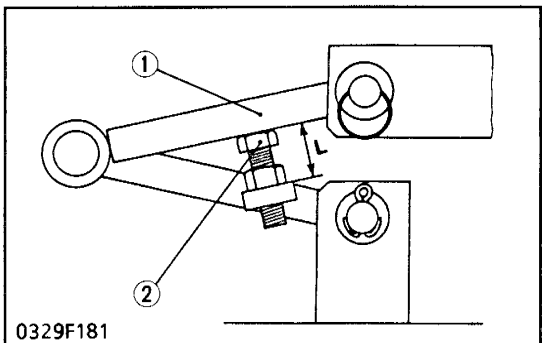

(1) Upper Link

(2) Front Stop Bolt

**Adjusting Connecting Rod**

1. Raise the tractor lower links at the maximum lifting position.
2. Adjust the length of both connecting rods with the turnbuckles until the front stop bolts (2) heads just contact the upper links (1) at the maximum lifting position of the mower.

**IMPORTANT**

- Proper adjustment of the connecting rod length is very important to avoid damage to the lift frame.
- Do not change the length (L) of the stop bolts.

Length of stop bolt (Front)	Factory spec.	RC72-29A		13 to 15 mm 0.51 to 0.59 in.
		RC72-36A	ROPS	25 to 27 mm 0.98 to 1.06 in.
			CABIN	31 to 33 mm 1.22 to 1.30 in.
Length of stop bolt (Rear)	Factory spec.	RC72-29A		21 to 23 mm 0.83 to 0.91 in.
		RC72-36A	ROPS	17 to 19 mm 0.67 to 0.75 in.
			CABIN	23 to 25 mm 0.91 to 0.98 in.

## DISASSEMBLING AND ASSEMBLING

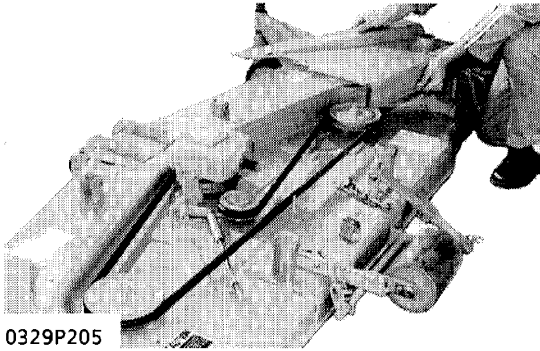

0329P205

### Shield

1. Remove the right and left pantograph linkage.
2. Remove the right and left shields.

#### (When reassembling)

- Spread the cotter pin completely.

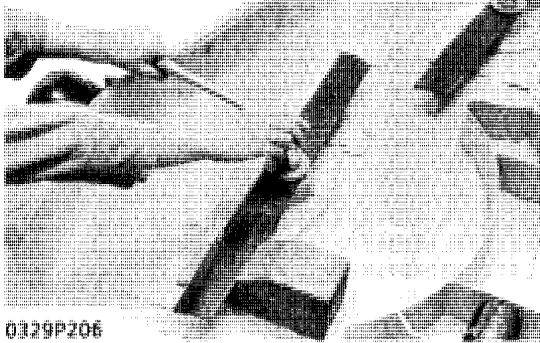

0329P206

### Blade

1. Turn over the mower.
2. Loosen the blade screw (5).
3. Remove the blade screw (5), friction washer (4), two cup washers (3) and blade (2).

#### ■ NOTE

- To remove the blade (2) securely, wedge a block of wood between one blade (2) and the housing in such position that it will hold the blade (2) safely while loosening or tightening the blade screw (5).

#### (When reassembling)

- Be sure to assemble the friction washer (4) and two cup washers (3) between the blade (2) and blade screw (5).

#### ■ IMPORTANT

- Make sure the two cup washers are not flattened out or worn, causing blade to slip easily. Replace two cup washers and friction washer if either is damaged.

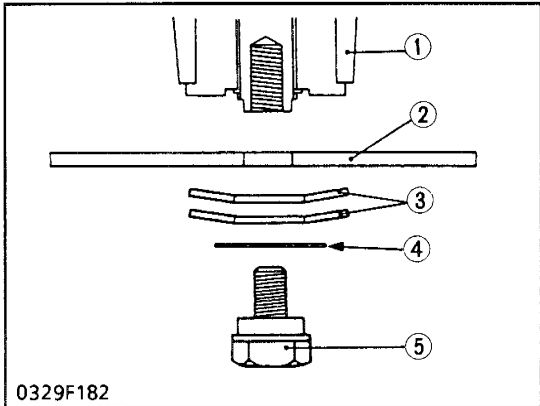

0329F182

Tightening torque	Blade screw	177 to 216 N·m 18 to 22 kgf·m 130 to 159 ft·lbs
-------------------	-------------	---

- |                    |                     |
|--------------------|---------------------|
| (1) Spindle Holder | (4) Friction Washer |
| (2) Blade          | (5) Blade Screw     |
| (3) Cup Washers    |                     |

### Blade Boss

1. Remove the external snap ring (2).
2. Remove the blade boss (1).

- |                |                        |
|----------------|------------------------|
| (1) Blade Boss | (2) External Snap Ring |
|----------------|------------------------|

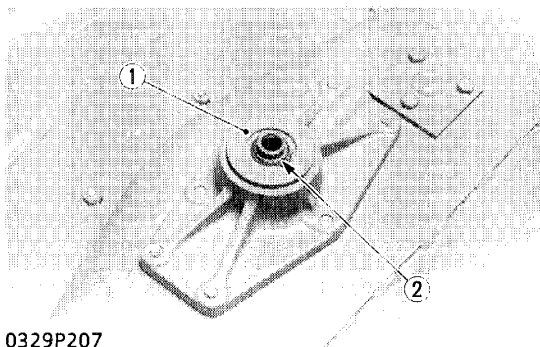

0329P207

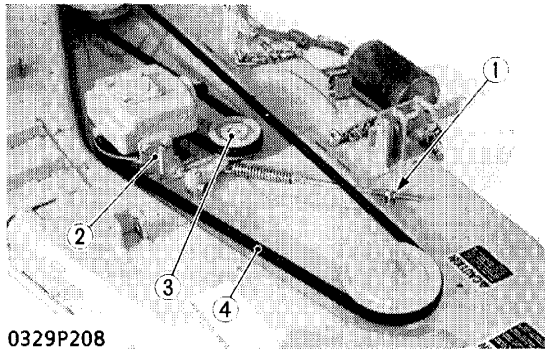

0329P208

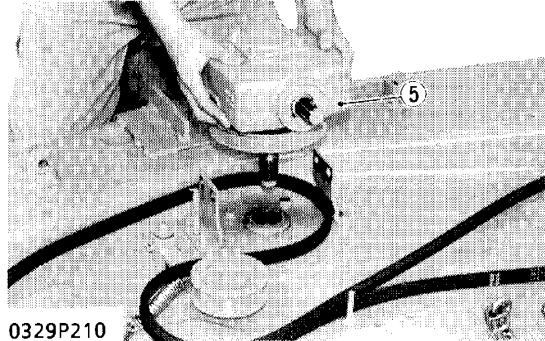

0329P210

**Gear Box**

1. Loosen the tension screws (1) and remove the V-belt (4).
2. Remove the gear box bracket (2).
3. Pull out the gear box (5) upward.
4. Loosen the drain plug.
5. Drain out gear oil.

**IMPORTANT**

- Before removing the belt, loosen the tension screw.

**(When reassembling)**

- After reassembling the V-belt, be sure to adjust the belt tension. (See page M-58.)

Capacity	Gear box oil	0.75 ℓ 0.79 U.S.qts. 0.66 Imp.qts.
----------	--------------	--

- |                      |              |
|----------------------|--------------|
| (1) Tension Screws   | (4) V-belt   |
| (2) Gear Box Bracket | (5) Gear Box |
| (3) Tension Pulley   |              |

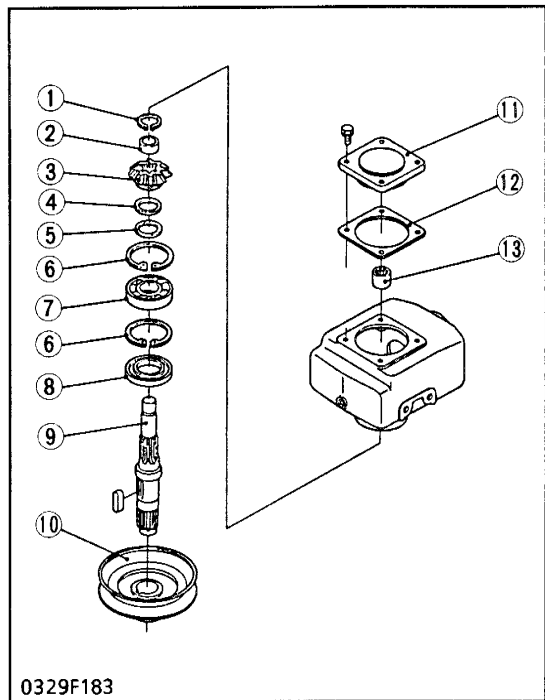

0329F183

**Spindle Shaft**

1. Remove the gear box cover (11).
2. Remove the external snap ring (1) and collar (2).
3. Remove the 17T bevel gear (3) and shims (4), (5).
4. Tap out the spindle shaft (9) downward.

- |                        |                     |
|------------------------|---------------------|
| (1) External Snap Ring | (8) Oil Seal        |
| (2) Collar             | (9) Spindle Shaft   |
| (3) 17T Bevel Gear     | (10) Pulley 1       |
| (4) Shim               | (11) Gear Box Cover |
| (5) Shim               | (12) Gasket         |
| (6) Internal Snap Ring | (13) Needle Bearing |
| (7) Ball Bearing       |                     |



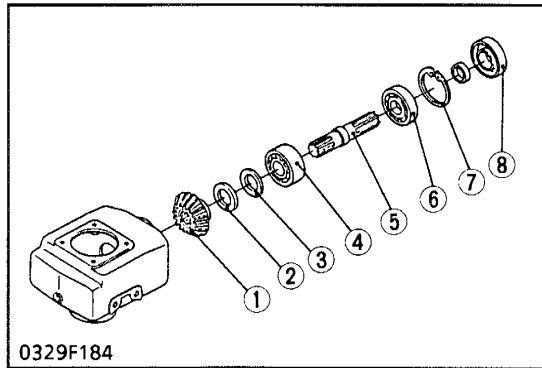

**Pinion Shaft**

1. Remove the 20T bevel gear (1) and shims (2), (3).
2. Remove the oil seal (8) and internal snap ring (7).
3. Tap out the pinion shaft (5).

**(When reassembling)**

- Check the backlash, tooth contact and turning torque. If not proper, adjust with the shims (2), (3). (Refer to **SERVICING**.)

- |                    |                        |
|--------------------|------------------------|
| (1) 20T Bevel Gear | (5) Pinion Shaft       |
| (2) Shim           | (6) Ball Bearing       |
| (3) Shim           | (7) Internal Snap Ring |
| (4) Ball Bearing   | (8) Oil Seal           |

**SERVICING**

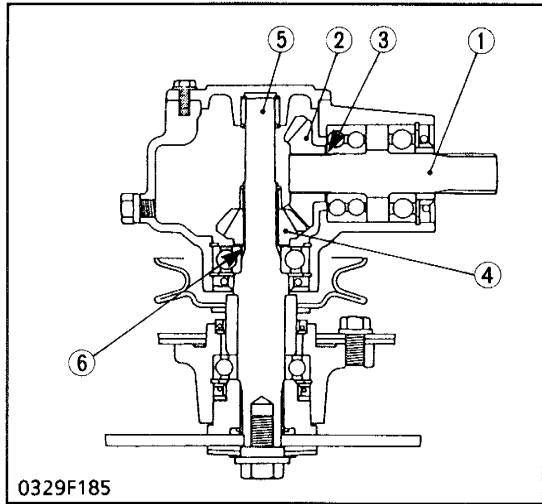

**Backlash between Bevel Gears**

1. Remove the gear box cap.
2. Place fuses on the 20T bevel gear (2).
3. Assemble the gear box cap, and turn the pinion shaft (1).
4. Remove the gear box cap again, and take out the fuses.
5. Measure the thickness of fuses with an outside micrometer. (Backlash equal thickness of fuse.)
6. If the backlash is not within the factory specifications, adjust with shims (3), (6).

Backlash between bevel gears	Factory spec.	0.13 to 0.25 mm 0.0051 to 0.0098 in.
------------------------------	---------------	---

**(Reference)**

- Thickness of adjusting shims (3), (6) : 0.2 mm (0.008 in.)  
0.3 mm (0.012 in.)

- |                    |                    |
|--------------------|--------------------|
| (1) Pinion Shaft   | (4) 17T Bevel Gear |
| (2) 20T Bevel Gear | (5) Spindle Shaft  |
| (3) Shim           | (6) Shim           |

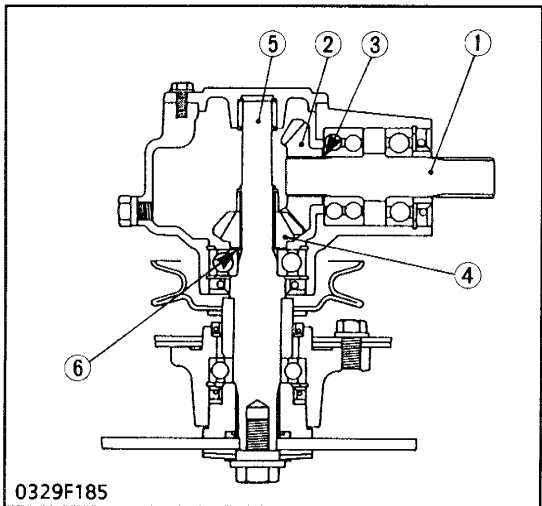

**Turning Torque of Pinion Shaft**

1. Remove the mower belt, and reassemble the gear box to the mower deck.
2. Measure the turning torque.
3. If the measurement exceeds the factory specification, check the bearing, gears, and adjust with the adjusting shims (3), (6).

Turning torque	Factory spec.	Less than 0.69 N·m 0.07 kgf·m 0.51 ft·lbs
----------------	---------------	---

**(Reference)**

- Thickness of adjusting shims (3), (6) : 0.2 mm (0.008 in.)  
0.3 mm (0.012 in.)

- |                    |                    |
|--------------------|--------------------|
| (1) Pinion Shaft   | (4) 17T Bevel Gear |
| (2) 20T Bevel Gear | (5) Spindle Shaft  |
| (3) Shim           | (6) Shim           |

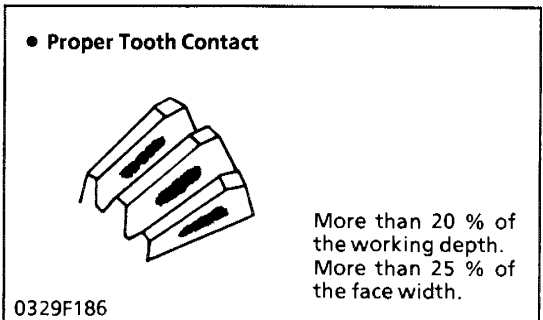

**Tooth Contact of Bevel Gears**

1. Check the tooth contact.
2. If it is not proper, adjust by the shims, where in back of the bevel gears.

**(Reference)**

- Thickness of adjusting shims : 0.2 mm (0.008 in.)  
0.3 mm (0.012 in.)



# **A L4610DT(Supplement)**

Use this workshop manual together with Workshop  
Manual for L3010, L3410, L3710, L4310 issued already.



## CONTENTS

SPECIFICATION .....	A-1
DIMENSIONS .....	A-3
<b>G</b> GENERAL .....	AG-1
<b>6</b> FRONT AXLE	
Mechanism .....	A6-M1
Servicing .....	A6-S1
<b>7</b> STEERING	
Mechanism .....	A7-M1
Servicing .....	A7-S1
<b>8</b> HYDRAULIC SYSTEM .....	A8-S1
<b>9</b> ELECTRICAL SYSTEM	
Mechanism .....	A9-M1
Servicing .....	A9-S1



## TO THE READER

This Workshop Manual has been prepared to provide servicing personnel with information on the mechanism, service and maintenance of KUBOTA L4610.

Covered here are additional sections for L4610 tractor.

As for the items which are not explained in these sections, refer to Workshop Manual for L3010, L3410, L3710, L4310.

All information, illustrations and specifications contained in this manual are based on the latest production information available at the time of publication.

The right is reserved to make changes in all information at any time without notice.

January 2000

© KUBOTA Corporation 2000

12191Z00010





# SPECIFICATIONS

Model		L4610		
		4WD-GST	4WD-HST	
Maximum PTO power		30.2 kW (40.5 HP)* / 2700	29.1 kW (39.0 HP)* / 2700	
Engine NET power		34.3 kW (46.0 HP)*		
Engine	Model	V2203-EHA		
	Type	Indirect injection, vertical, water-cooled, 4-cycle diesel engine		
	Number of cylinders	4		
	Bore and stroke	87 × 92.4 mm (3.4 × 3.6 in.)		
	Total displacement	2197 cm <sup>3</sup> (134.1 cu.in.)		
	Rated revolution	45.0 r/s (2700 rpm)		
	Combustion chamber	Spherical type (E-TVCS)		
	Fuel injection pump	Bosch type mini pump (PFR4M)		
	Governor	Centrifugal ball mechanical governor		
	Injection nozzle	Throttle type		
	Injection timing	Before T.D.C. 0.314 rad. (18°)		
	Injection order	1-3-4-2		
	Injection pressure	13.73 MPa (140 kgf/cm <sup>2</sup> , 1991 psi)		
	Compression ratio	23 : 1		
	Lubricating system	Forced lubrication by trochoidal pump		
	Cooling system	Pressurized radiator, Forced circulation with water pump		
	Starting system	Electric starting with cell starter 12 V, 1.4 kW		
	Alternator	12 V, 480 W (40 AMPS)		
	Battery	12V, RC : 137 min, CCA : 447-Cold cranking Amps at - 18 °C (- 0.4 °C)		
	Fuel	Diesel fuel No.1 [below - 10 °C (14 °F)] Diesel fuel No.2 [above - 10 °C (14 °F)]		
Lubricating oil	CC or CD (API grade)			
Weight (Dry)	206.5 kg (455 lbs)			
Capacities	Fuel tank	35.0 L (9.2 U.S.gal., 7.7 Imp.gal.)		
	Engine crankcase	7.6 L (8.0 U.S.qts., 6.7 Imp.qts.)		
	Engine coolant	7.5 L (7.9 U.S.gts., 7.0 Imp.qts.)		
	Transmission case	39.0 L (10.3 U.S.gal., 8.6 Imp.gal.)		
	Front axle case	7.5 L (7.9 U.S.qts., 6.6 Imp.qts.)		
Dimensions (with Std. tires)	Overall length (without 3P)		3020 mm (118.9 in.)	
	Overall length (with 3P)		3230 mm (127.2 in.)	
	Overall width (Minimum tread)		1585 mm (62.4 in.)	
	Overall height	Top of ROPS	2155 mm (84.8 in.)	
		Top of CABINE	2175 mm (85.6 in.)	
	Overall height (Top of steering wheel)		1535 mm (60.4 in.)	
	Wheel base		1815 mm (71.5 in.)	
	Minimum ground clearance (Under transmission)		380 mm (15.0 in.)	
	Tread	Front mm (in.)	1290 (50.8)	
Rear mm (in.)		1180 (46.5), 1200 (47.2), 1300 (51.2), 1450 (57.1), 1545 (60.8)		

12191Z00020

Model			L4610	
			4WD-GST	4WD-HST
Travelling system	Tire size (Std. tires)	Front	8.3 – 16	
		Rear	14.9 – 24	
	Clutch		Dry type single stage	
	Steering		Hydrostatic power steering	
	Transmission		Glide shift transmission (8 forward and 8 reverse speeds)	Hydraulic transmission (3 speeds)
	Brake	Travelling	Wet disc type	
		Parking	Connected with the travelling brake	
Differential		Bevel gear		
Hydraulic system	Hydraulic control system		Position control, Draft and Mixed control (if equipped)	
	Pump capacity (Max. flow rate)		Main pump 36.4 L/min. (9.6 GPM),	
	Three point hitch		SAE Category I	
	Maximum lifting capacity (24 in. behind lower link end)		1050 kg (2310 lbs)	
Rear PTO	PTO shaft		SAE 1-3/8, 6-splines (with overrunning clutch)	
	Revolution	Independent PTO	1 speed : 9.0 r/s (540 rpm) / engine 45.0 r/s (2700 rpm)	
Min. turning radius (with brake)			2.7 m (8.9 ft)	
Traction system			Fixed drawbar or swing drawbar (if equipped)	
Weight	Rops		1440 kg (3180 lbs)	1450 kg (3200 lbs)
	Cabin		–	1655 kg (3650 lbs)
Traveling speed (at rated engine speed with Std. tires)	Forward	1st	1.5 km/h (0.9 mph)	Low : 0 to 6.0 km/h (0 to 3.7 mph)
		2nd	2.1 km/h (1.3 mph)	
		3rd	3.5 km/h (2.2 mph)	
		4th	5.6 km/h (3.5 mph)	Middle : 0 to 11.2 km/h (0 to 7.0 mph)
		5th	7.3 km/h (4.6 mph)	High : 0 to 27.8 km/h (0 to 17.3 mph)
		6th	10.3 km/h (6.4 mph)	
		7th	16.7 km/h (10.4 mph)	
		8th	26.9 km/h (16.7 mph)	
	Reverse	1st	1.4 km/h (0.9 mph)	Low : 0 to 4.8 km/h (0 to 3.0 mph)
		2nd	2.0 km/h (1.2 mph)	
		3rd	3.2 km/h (2.0 mph)	
		4th	5.1 km/h (3.2 mph)	Middle : 0 to 9.0 (0 to 5.6 mph)
		5th	6.7 km/h (4.2 mph)	High : 0 to 22.2 km/h (0 to 13.8 mph)
		6th	9.4 km/h (5.8 mph)	
		7th	15.3 km/h (9.5 mph)	
		8th	24.7 km/h (15.4 mph)	

12191Z00030

# DIMENSIONS

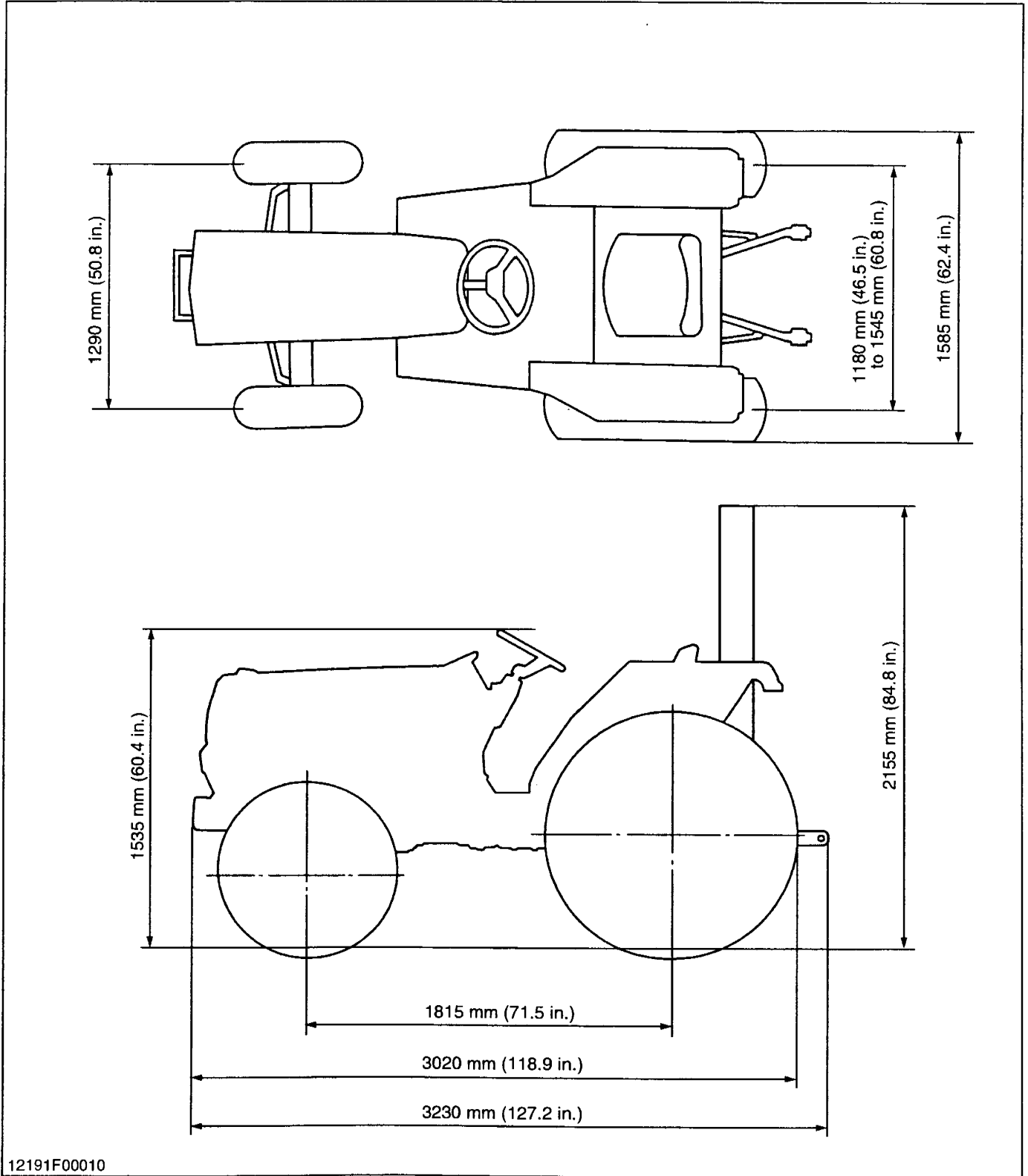

12191F00010

12191Z00040

[CABIN]

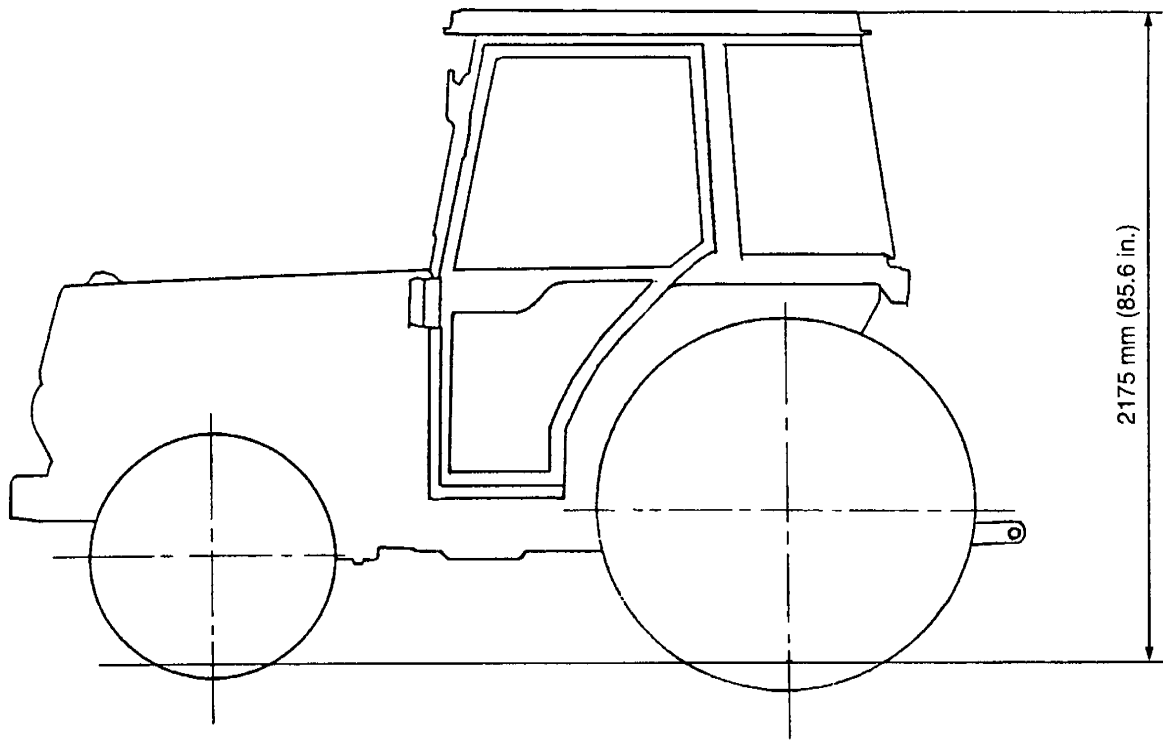

12190F00030

12191Z00050

# G GENERAL

## [1] LUBRICANTS, FUEL AND COOLING WATER

No.	Place	Capacity	Lubricants, fuel and cooling water	
		L4610		
1	Fuel tank	35 L 9.2 U.S.gals. 7.7 Imp.gals.	No. 2-D diesel fuel No. 1-D diesel fuel if temperature is below - 10 °C (14 °F)	
2	Cooling system	7.5 L 7.9 U.S.qts. 6.6 Imp.qts.	Fresh clean water with anti-freeze	
3	Engine crankcase	7.6 L 8.0 U.S.qts. 7.0 Imp.qts	Engine oil : API Service CC or CD Below 0 °C (32 °F) ..... SAE10W, 10W-30 or 10W-40 0 to 25 °C (32 to 77 °F) .... SAE20, 10W-30 or 10W-40 Above 25 °C (77 °F) ..... SAE30, 10W-30 or 10W-40	
4	Transmission case	39 L 41.2 U.S.gals. 34.3 Imp.gals.	KUBOTA SUPER UDT fluid *	
5	Front axle case [4WD]	7.5 L 7.9 U.S.qts. 6.6 Imp.qts	KUBOTA SUPER UDT fluid * or SAE80, 90 gear oil	
<b>Greasing</b>				
6	Front wheel case support (RH, LH)	Until grease overflows	2 points	SAE multi-purpose type grease
	Front axle support		2 points	
	Top link		1 points	
	Lift rod		2 points	
	Power steering cylinder		1 points	
	Battery terminal	Moderate amount	2 points	

\* KUBOTA original transmission hydraulic fluid.

12191G00010

## [2] CHECK AND MAINTENANCE

Only the maintenance item added by L4610 is described in this section. Please refer to the section of GENERAL for other maintenance items.

12191G00020

### (1) Check Points of Every 50 Hours

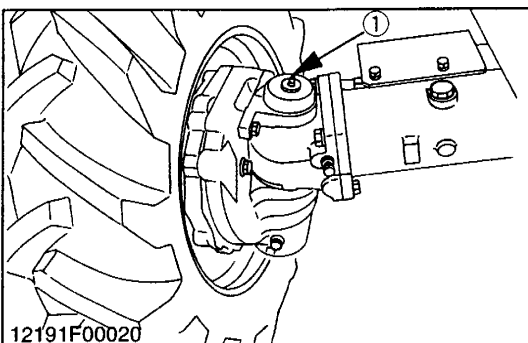

12191F00020

#### Greasing

1. Apply grease to the Front wheel case support. (RH , LH)

(1) Grease fitting (Front wheel case support) [RH ,LH]

12191G00030

**(2) Check Points of Every 200 Hours**

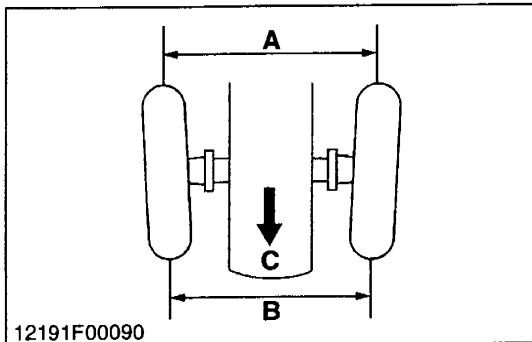

12191F00090

**Adjusting Toe-in**

1. Park the tractor on the flat place.
2. Inflate the tires to the specified preaaure.
3. Turn the front wheels straight ahead.
4. Measure the distance between the centers of front wheels at front and rear.
5. If the measurement is not within the factory specifications, adjust by changing the tie-rod length.

Toe-in (A-B)	Factory spec.	2 to 8 mm 0.1 to 0.3 in.
--------------	---------------	-----------------------------

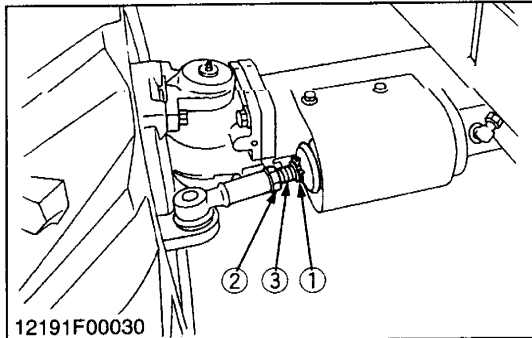

12191F00030

**Adjustment**

1. Detach the snap ring.
2. Loosen the tie-rod nut.
3. Turn the tie-rod joint to adjust the rod length until the proper toe-in measurement is obtained.
4. Retighten the tie-rod nut.
5. Attach the snap ring of the tie-rod joint.

- |                   |                                      |
|-------------------|--------------------------------------|
| (1) Snap ring     | (A) Wheel-to-wheel distance at rear  |
| (2) Tie-rod nut   | (B) Wheel-to-wheel distance at front |
| (3) Tie-rod joint | (C) "FRONT"                          |

12191G00040

**(3) Check Points of Every 400 Hours**

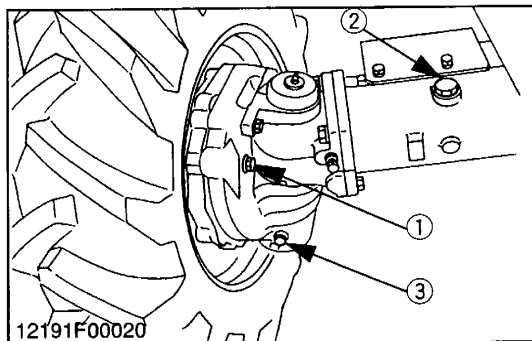

12191F00020

**Changing Front Axle Case Oil**

1. To drain the used oil, remove the right and left drain plugs (3) and filling plug (2) at the front axle case and drain the oil completely into the oil pan.
2. After draining reinstall the drain plugs (3).
3. Remove the oil level check plug (1).
4. Fill with the new oil up to the check plug port. (See "LUBRICANTS" in Maintenance Section)
5. After filling reinstall the filling plug (2) check piug (1).

Oil capacity	L4610	7.5 L 7.9 U.S.qts. 6.6 Imp.qts.
--------------	-------	---------------------------------------

- |                  |                |
|------------------|----------------|
| (1) Check plug   | (3) Drain plug |
| (2) Filling plug |                |

12191G00050

**(4) Check Points of Every 600 Hours**

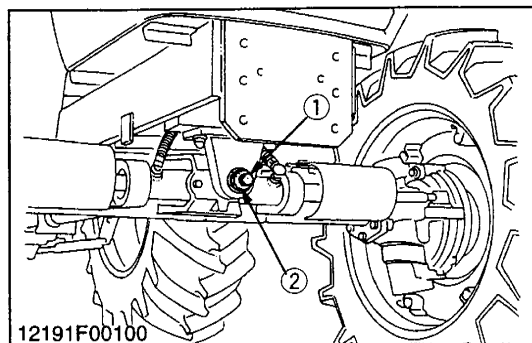

12191F00100

**Adjusting Front Axle Pivot**

1. Jack up the tractor body, then loosen the lock nut (2).
2. Measure the adjusting screw tightening torque.
3. If tightening torque is not within the factory specifications, adjust the adjusting screw (1).
4. After adjustment, tighten the lock nut firmly.

**(When reassembling)**

Tightening torque	Front axle adjusting screw	19.6 to 29.4 N-m 2.0 to 3.0 kgf-m 14.5 to 21.7 ft-lbs
	Lock nut	98.1 to 147.1 N-m 10.0 to 15.0 kgf-m 72.3 to 108.5 ft-lbs

- |                     |              |
|---------------------|--------------|
| (1) Adjusting Screw | (2) Lock Nut |
|---------------------|--------------|

12191G00060

### [3] TIRES

#### (1) Types of Tire

The following tires can be mounted on model L4610.

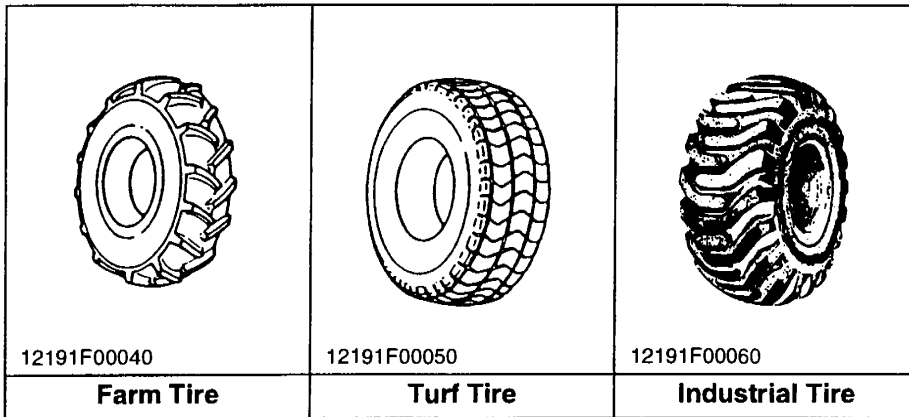

Model	Type of Tire	Front	Rear
L4610 4WD	Farm Tire	8.3-16 std.	14.9-24 std.
			13.6-24 opt.
	Turf Tire	27 × 8.50-15 opt. 29 × 12.50-15 opt.	355 / 80-D20 opt.
			21.5 L-16.1 opt.
Industrial Tire	10-16.5 opt.	17.5 L-24 opt.	

12191G00070

#### (2) Tread Adjustment

##### (2)-1 Front Wheels

[4WD Type]

Front axle is not adjustable.

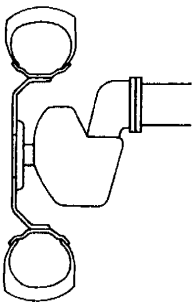
	L4610			
	Tire	8.3-16 Farm	27 × 8.50-15 Turf	29 × 12.50-15 Turf
Tread	1290 mm (50.8 in.)	1335 mm (52.6 in.)	1415 mm (55.7 in.)	1365 mm (53.7 in.)

12191F00070

12191G00080

## (2)-2 Rear Wheels

Rear tread can be adjusted in 6 steps depending on the model.

To change the tread

1. Lift the rear tires off the ground.
2. Follow the illustrations below to get the desired tread width.

**⚠ CAUTION**

- When working on slopes or working with trailer, set the wheel tread as wide as practical for the job for maximum stability.

**■ IMPORTANT**

- Always attach tires as shown in the drawings below.
- If not attached as illustrated, transmission pats may be damaged.
- Do not use tires larger than specified.

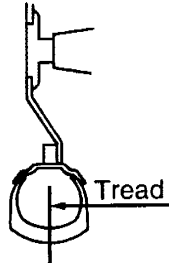
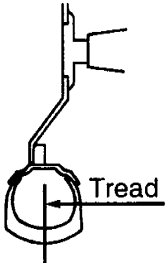
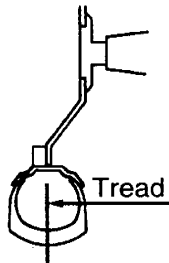
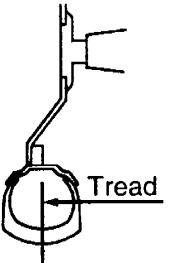
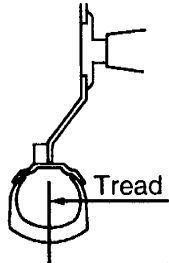
Models					
12191F00080					
L4610 13.6-24 Farm	1180 mm (46.5 in.)	1200 mm (47.2 in.)	1300 mm (51.2 in.)	1450 mm (57.1 in.)	1545 mm (60.8 in.)
L4610 14.9-24 Farm	1180 mm (46.5 in.)	1200 mm (47.2 in.)	1300 mm (51.2 in.)	1450 mm (57.1 in.)	1545 mm (60.8 in.)
L4610 17.5L-24 Industrial	—	1245 mm (49.0 in.)	1355 mm (53.3 in.)	1395 mm (54.9 in.)	1505 mm (59.3 in.)

12191G00090

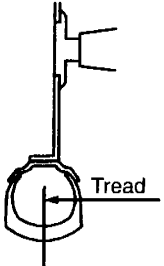

<p>Models</p> <p>12191F00110</p>	
<p>L4610 21.5L-16.1 Turf</p>	<p>1350 mm (53.1 in.)</p>
<p>L4610 21.5L-16.1 Turf</p>	<p>1460 mm (57.5 in.)</p>
<p>L4610 355/80-D20 Turf</p>	<p>1150 mm (45.3 in.)</p>
<p>L4610 355/80-D20 Turf</p>	<p>1265 mm (49.8 in.)</p>

12191G00100

### [4] SPECIFICATIONS OF IMPLEMENT LIMITATIONS

The KUBOTA Tractor has been thoroughly tested for proper performance with implements sold or approved by KUBOTA. Use with implements which exceed the maximum specifications listed below, or otherwise unfit for use with the KUBOTA Tractor may result in malfunctions or failures of the tractor, damage to other property and injury to the operator or others. (Any malfunctions or failures of the tractor resulting from use with improper implements are not covered by the warranty.)

	Tread (max. width) with farm tires		Lower link end max. Lift Capacity $W_0$
	Front	Rear	
	4WD		
L4610	1290 mm (50.8 in.)	1545 mm (60.8 in.)	1300 kg (2870 lbs.)

	Actual figures		
	Trailer loading weight $W_2$ Max. capacity	Max. Drawbar Load $W_3$ 4WD	Lift capacity 24 inch behind lower link end $W_1$
	4WD		
L4610	3000 kg (6600 lbs.)	650 kg (1430 lbs.)	1050 kg (2310 lbs.)

Lower link end max. lift capacity .....  $W_0$   
 Implement weight ..... The implement's weight which can be put on the lower link :  $W_1$   
 Trailer loading weight..... The max. loading weight for trailer (without traier's weight) :  $W_2$

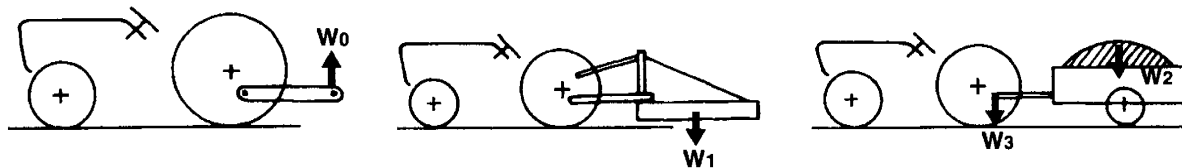

11790F00750

12191G00110

No.	Implement		Remarks	L4610	
1	Trailer		Max. Load Capacity	kg (lbs.)	3000 (6600)
			Max. Drawbar Load	kg (lbs.)	650 (1430)
2	Mower	Mid-mount	Max. Cutting Width	mm (in.)	—
			Max. Weight	kg (lbs.)	—
		Rotary-Cutter	Max. Cutting Width	mm (in.)	1829 (72)
			Max. Weight	kg (lbs.)	400 (880)
		Flail Mower	Max. Cutting Width	mm (in.)	1524 (60)
			Max. Weight	kg (lbs.)	400 (880)
		Sickle Bar	Max. Cutting Width	mm (in.)	2133 (84)
			Max. Weight	kg (lbs.)	500 (1100)
3	Sprayer	Rear mounted	Max. Tank capacity	L (gal.)	400 (106)
		Pull type	Max. Tank capacity	L (gal.)	1200 (317)
4	Rotary Tiller		Max. Tilling Width	mm (in.)	1520 (60)
5	Bottom Plow		Max. Size		14 in. × 2
6	Disc harrow : Pull type		Max. Harrowing Width	mm (in.)	1981 (78)
			Max. Weight	kg (lbs.)	400 (880)
7	Chisel Plow		Max. Width	mm (in.)	1829 (72)
			Max. Weight	kg (lbs.)	350 (770)
8	Broad Caster		Max. Tank capacity	L (gal.)	300 (80)
			Max. Weight	kg (lbs.)	100 (220)
9	Manure Spreder		Max. Capacity	kg (lbs.)	2000 (4400)
10	Cultivator		Max. Width	mm (in.)	2134 (84)
			Number of Rows		2
			Max. Weight	kg (lbs.)	400 (880)
11	Front Blade		Max. Cutting Width	mm (in.)	1829 (72)
			Max. Oil Pressure	kgf/cm <sup>2</sup> (psi)	175 (2490)
			Sub Frame		Necessary
12	Rear Blade		Max. Cutting Width	mm (in.)	1829 (72)
			Max. Oil Pressure	kgf/cm <sup>2</sup> (psi)	175 (2490)
13	Front-end Loader		Max. Lifting Capacity	kgf (lbs.)	850 (1880)
			Max. Oil Pressure	kgf/cm <sup>2</sup> (psi)	175 (2490)
			Sub Frame		Necessary
14	Box Blade		Max. Cutting Width	mm (in.)	1651 (65)
			Max. Weight	kg (lbs.)	350 (770)
15	Back Hoe		Max. Digging Depth	mm (in.)	2288 (90)
			Max. Weight	kg (lbs.)	450 (990)
			Sub Frame		Necessary
16	Snow Blade		Max. Width	mm (in.)	1830 (72)
			Max. Weight	kg (lbs.)	350 (770)
17	Snow Blower		Max. Working Width	mm (in.)	1676 (66)
			Max. Weight	kg (lbs.)	280 (620)

**NOTE :**

- Implement size may vary depending on soil and operating conditions.

12191G00120

—— MEMO ——

## 6 FRONT AXLE

### [1] STRUCTURE

The front axle supports the front of tractor and facilitates steering.

There are two kinds of front axles.

The two-wheel drive axle has free-running front wheels and the four-wheel drive axle has powered front wheels.

11790M60010

#### (1) 4 Wheel Drive Type

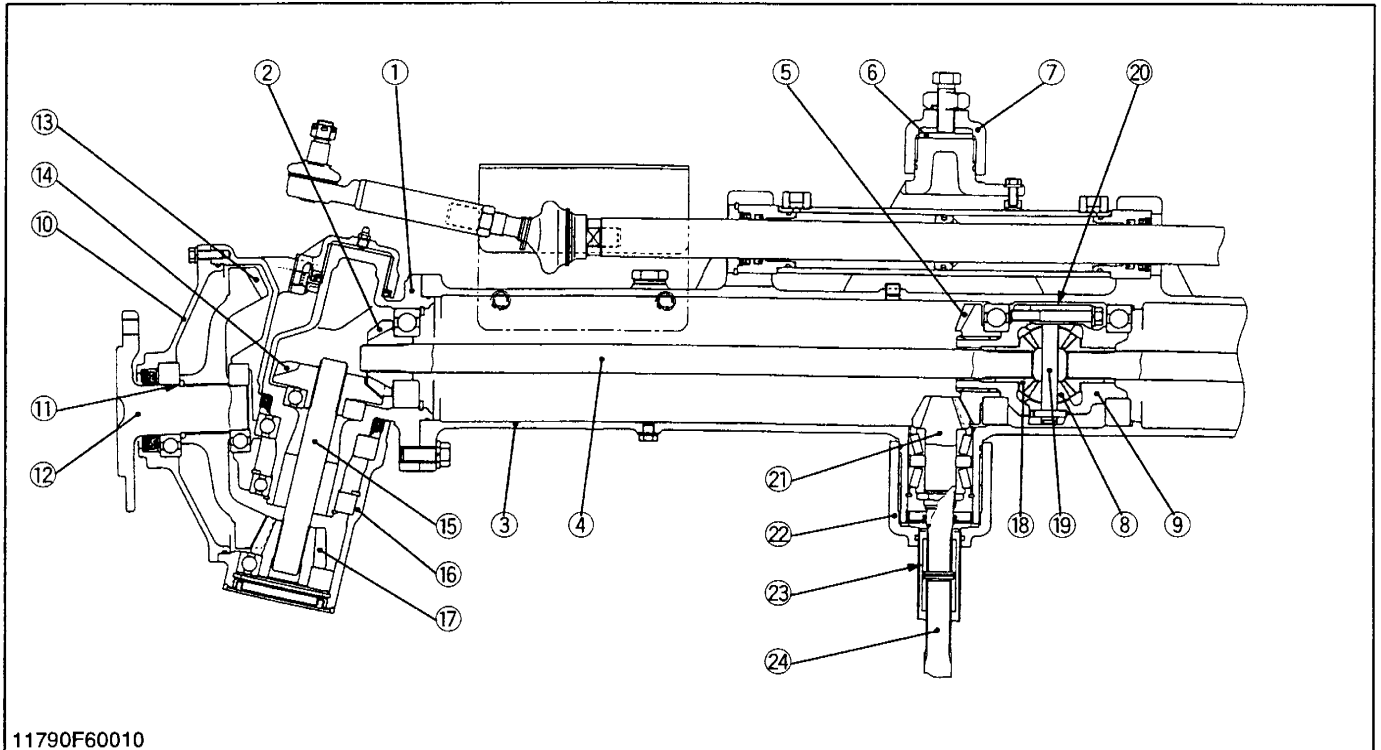

11790F60010

- |                             |                               |                             |                                |
|-----------------------------|-------------------------------|-----------------------------|--------------------------------|
| (1) Bevel Gear Case         | (7) Front Axle Bracket, Front | (13) Bevel Gear             | (19) Pinion Shaft              |
| (2) Bevel Gear              | (8) Differential Pinion       | (14) Bevel Gear             | (20) Differential Assembly     |
| (3) Front Axle Case         | (9) Differential Case         | (15) Bevel Gear Shaft       | (21) Spiral Bevel Pinion Shaft |
| (4) Differential Yoke Shaft | (10) Axle Flange              | (16) Front Gear Case        | (22) Front Axle Bracket, Rear  |
| (5) Spiral Bevel Gear       | (11) Collar                   | (17) Bevel Gear             | (23) Coupling                  |
| (6) Collar                  | (12) Axle                     | (18) Differential Side Gear | (24) Propeller Shaft           |

The front axle of the 4WD is constructed as shown above. Power is transmitted from the transmission through the propeller shaft (24) and to the spiral bevel pinion shaft (21), then to the spiral bevel gear (5) after that to the differential gear.

The power through the differential is transmitted to

the differential yoke shaft (4), and to the bevel gear shaft (15) in the bevel gear case (1).

The revolution is greatly reduced by the bevel gears (17), (13), then the power is transmitted to the axle (12).

The differential system allows each wheel to rotate at a different speed to make turning easier.

11790M60030

—— MEMO ——

## TROUBLESHOOTING

Symptom	Probable Cause	Solution	Reference Page
<b>Front Wheels Wander to Right or Left</b>	<ul style="list-style-type: none"> <li>• Tire pressure uneven</li> <li>• Improper toe-in adjustment (improper alignment)</li> <li>• Clearance between front axle case boss and front axle bracket (front, rear) bushing excessive [4WD Type]</li> <li>• Front axle rocking force too small</li> <li>• Front wheel sway excessive</li> <li>• Tie-rod end loose</li> </ul>	Adjust Adjust Replace Adjust Replace Tighten	G-39 A6-S4 A6-S7, S16 A6-S5 A6-S5 A6-S7
<b>Front Wheels Can Not Be Driven [4WD Type]</b>	<ul style="list-style-type: none"> <li>• Propeller shaft broken</li> <li>• Front wheel drive gears in transmission broken</li> <li>• Front differential gear broken</li> <li>• Shift fork broken</li> <li>• Coupling displaced</li> </ul>	Replace Replace Replace Replace Reassemble	A6-S6 – A6-S6 to S12 – A6-S6
<b>Noise [4WD Type]</b>	<ul style="list-style-type: none"> <li>• Gear backlash excessive</li> <li>• Oil insufficient</li> <li>• Bearings damaged or broken</li> <li>• Gears damaged or broken</li> <li>• Spiral bevel pinion shaft turning force improper</li> </ul>	Adjust or replace Replenish Replace Replace Adjust	A6-S13, S14 AG-1 – – A6-S11

12191S60010

# SERVICING SPECIFICATIONS

## 4WD TYPE

Item		Factory Specification	Allowable Limit
Front Wheel Alignment	Toe-in	2 to 8 mm 0.08 to 0.32 in.	—
Front Wheel	Steering Angle	0.925 to 0.960 rad. 53 to 55°	—
	Axial Sway	5.0 mm 0.196 in.	—
	Radial Sway	5.0 mm 0.196 in.	—
Front Axle	Swing Angle	0.122 to 0.157 rad. 7 to 9°	—
Differential Case, Differential Case Cover to Differential Side Gear	Clearance	0.04 to 0.123 mm 0.00157 to 0.00484 in.	0.20 mm 0.0079 in.
Differential Case	I.D.	32.000 to 32.062 mm 1.25984 to 1.26228 in.	—
Differential Case Cover	I.D.	32.000 to 32.062 mm 1.25984 to 1.26228 in.	—
Differential Side Gear	O.D.	31.939 to 31.960 mm 1.25744 to 1.25827 in.	—
Pinion Shaft to Differential Pinion	Clearance	0.064 to 0.100 mm 0.00252 to 0.00394 in.	0.25 mm 0.0096 in.
Pinion Shaft	O.D.	13.950 to 13.968 mm 0.54921 to 0.54992 in.	—
Differential Pinion	I.D.	14.032 to 14.050 mm 0.55244 to 0.55315 in.	—

11790S60370



**4WD TYPE (Continued)**

Item		Factory Specification	Allowable Limit
Differential Pinion to Differential Side Gear	Backlash	0.2 to 0.3 mm 0.008 to 0.012 in.	0.4 mm 0.016 in.
Spiral Bevel Pinion Shaft	Turning Torque	0.98 to 1.18 N 0.10 to 0.12 kgf 0.72 to 0.87 ft-lbs	—
Spiral Bevel Pinion Shaft to Spiral Bevel Gear	Backlash	0.2 to 0.3 mm 0.008 to 0.012 in.	0.4 mm 0.016 in.
10T Bevel Gear to 14T Bevel Gear	Backlash	0.2 to 0.3 mm 0.0079 to 0.0118 in.	0.6 mm 0.024 in.
9T Bevel Gear to 43T Bevel Gear	Backlash	0.25 to 0.35 mm 0.0098 to 0.0138 in.	0.6 mm 0.024 in.
Front Axle Case Boss (Front) to Bracket Bushing	Clearance	0.025 to 0.160 mm 0.00098 to 0.00630 in.	0.35 mm 0.0138 in.
Front Axle Case Boss (Front)	O.D.	49.950 to 49.975 mm 1.96653 to 1.96752 in.	—
Bushing	I.D.	50.000 to 50.110 mm 1.96850 to 1.97283 in.	—
Front Axle Case Boss (Rear) to Bracket Bushing	Clearance	0.025 to 0.190 mm 0.00098 to 0.00748 in.	0.35 mm 0.0138 in.
Front Axle Case Boss (Rear)	O.D.	70.000 to 70.035 mm 2.75590 to 2.75728 in.	—
Bushing	I.D.	70.060 to 70.190 mm 2.75826 to 2.76338 in.	—
Bevel Gear Case Boss to Front Axle Support Bushing	Clearance	0.060 to 0.220 mm 0.00236 to 0.00866 in.	0.50 mm 0.0197 in.
Bevel Gear Case Boss	O.D.	54.970 to 55.000 mm 2.16417 to 2.16535 in.	—
Front Axle Support Bushing	I.D.	55.060 to 55.190 mm 2.16772 to 2.17283 in.	—

12191S60020

# TIGHTENING TORQUES

Tightening torques of screws, bolts and nuts on the table below are especially specified.  
(For general use screws, bolts and nuts : See page G-9.)

## 4WD TYPE

Item	N·m	kgf·m	ft·lbs
Power steering hose retaining nut	24.5 to 29.4	2.5 to 3.0	18.1 to 21.7
Cylinder cover	60.8 to 70.6	6.2 to 7.2	44.8 to 52.1
Tie-rod joint and steering cylinder mounting screw	166.7 to 196.1	17.0 to 20.0	122.9 to 144.6
Front wheel mounting nut	166.7 to 196.1	17.0 to 20.0	122.9 to 144.6
Front bracket and rear bracket mounting screw	77.5 to 90.1	7.9 to 9.2	57.2 to 66.5
Front bracket and rear bracket mounting nut	77.5 to 90.1	7.9 to 9.2	57.2 to 66.5
Tie-rod end nut	156.9 to 176.5	16.0 to 18.0	115.7 to 130.2
Tie-rod joint lock nut	166.7 to 196.1	17.0 to 20.0	122.9 to 144.6
Bevel gear case mounting screw	166.7 to 196.1	17.0 to 20.0	122.9 to 144.6
Front axle rocking force adjusting screw	19.6 to 29.4	2.0 to 3.0	14.5 to 21.7
Front axle rocking force adjusting lock nut	98.1 to 147.1	10.0 to 15.0	72.3 to 108.5
Front wheel case support mounting screw	77.5 to 90.1	7.9 to 9.2	57.2 to 66.5
Axle flange mounting screw	29.4 to 34.3	3.0 to 3.5	21.7 to 25.3
Differential case cover mounting screw	60.8 to 70.6	6.2 to 7.2	44.8 to 52.1

12191S60030

# CHECKING, DISASSEMBLING AND SERVICING

## CHECKING AND ADJUSTING

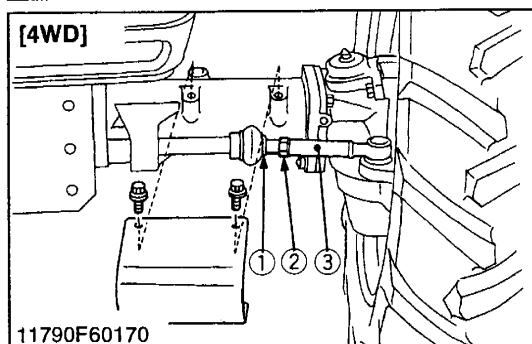
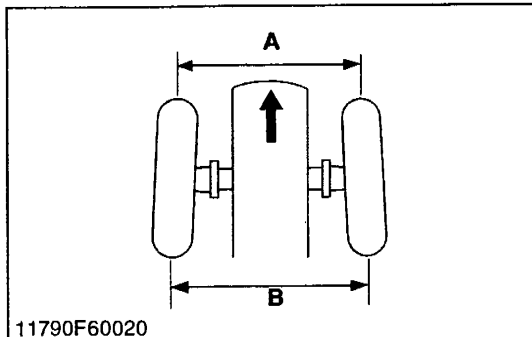

### Toe-in

1. Inflate the tires to the specified pressure.
2. Turn the front wheels straight ahead.
3. Measure the toe-in (A-B).
4. If the measurement is not within the factory specifications, adjust the tie-rod length.

Toe-in (A-B)	Factory spec.	4WD	2 to 8 mm 0.08 to 0.32 in.

### ■ Toe-in Adjustment

1. Detach the snap ring (1).
2. Loosen the tie-rod nut (2).
3. Turn the tie-rod joint (3) to adjust the rod length until the proper toe-in measurement is obtained.
4. Retighten the tie-rod nut (2).
5. Attach the snap ring (1) of the tie-rod joint (3).

- (1) Snap Ring  
(2) Tie-rod Nut

- (3) Tie-rod Joint

11790S60020

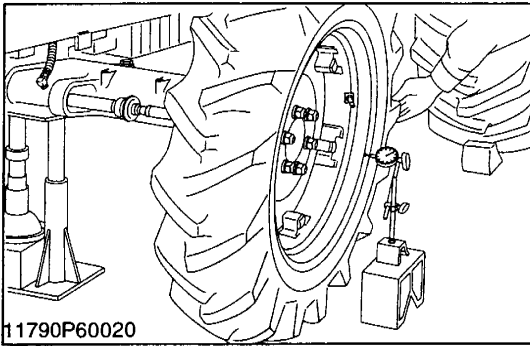

**Axial Sway of Front Wheel**

1. Jack up the front side of tractor.
2. Set a dial gauge on the outside of rim.
3. Turn the wheel slowly and read the runout of rim.
4. If the measurement exceeds the factory specifications, check the bearing, rim and front wheel hub.

Axial sway of front wheel	Factory spec.	Less than 5.0 mm 0.197 in.
---------------------------	---------------	-------------------------------

11790S60030

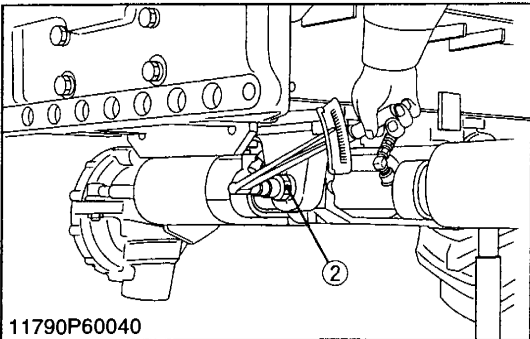

**Adjusting Front Axle Pivot**

1. Jack up the tractor body, then loosen the lock nut (2).
2. Measure the adjusting screw tightening torque.
3. If tightening torque is not within the factory specifications, adjust the adjusting screw (1).
4. After adjustment, tighten the lock nut firmly.

Tightening torque	Front axle adjusting screw	19.6 to 29.4 N·m 2.0 to 3.0 kgf·m 14.5 to 21.7 ft-lbs
	Lock nut	98.1 to 147.1 N·m 10.0 to 15.0 kgf·m 72.3 to 108.5 ft-lbs

(1) Adjusting Screw

(2) Lock Nut

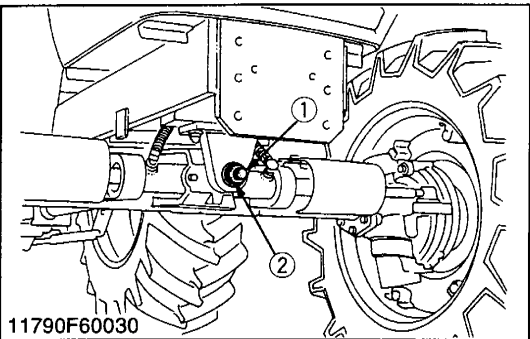

11790S60041

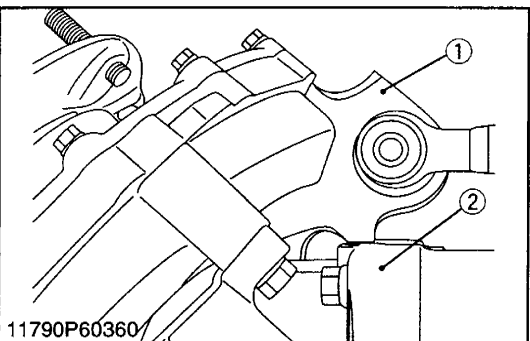

**Front Wheel Steering Angle (4WD Only)**

1. Inflate the tires to the specified pressure.
2. Steer the wheels to the extreme right until the front gear case (1) contacts with the bevel gear case (2) at right hand side of the front axle.
3. If the front gear case (1) can not be contacted with the bevel gear case (2), shorten the length of stopper (3).
4. Keeping the front gear case (1) contact with the bevel gear case (2), make a specified clearance (A) as shown in the lower table.
5. After adjustment, secure the stopper with the lock nut (4).
6. For adjusting the left steering angle, perform the same procedure as mentioned in right steering angle.

Clearance (A) between bevel gear case and stopper	Factory spec.	1.0 to 3.0 mm 0.04 to 0.12 in.
---	---------------	-----------------------------------

- (1) Front Gear Case
- (2) Bevel Gear Case
- (3) Stopper
- (4) Lock Nut

(5) Front Gear Case

(A) Clearance

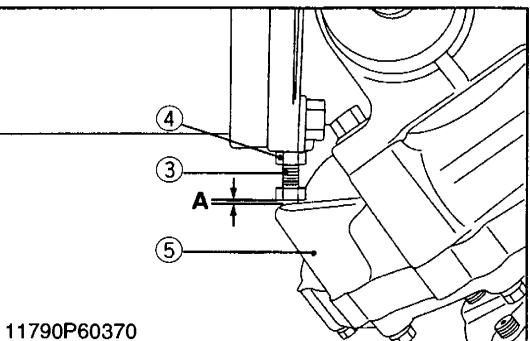

11790S60400

# DISASSEMBLING AND ASSEMBLING

## (1) Separating Front Axle [4WD Type]

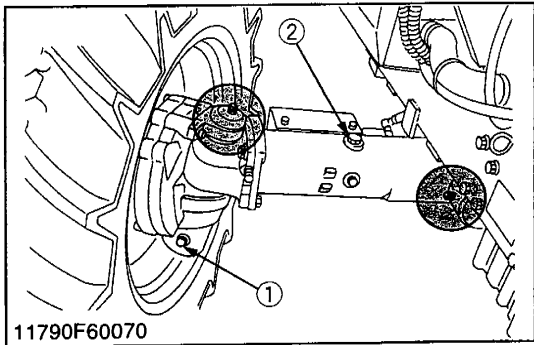

### Draining Front Axle Case Oil

1. Place oil pans underneath the front axle case.
2. Remove the drain plug (1) both sides and filling port plug (2) to drain the oil.
3. After draining, reinstall the drain plugs (1) and filling port plug (2).

### (When reassembling)

- Remove the filling port plug (2).
- Fill with the new oil.
- After filling, reinstall the filling port plug (2).

Capacity	Front axle case oil	8 L 8.5 U.S.qts. 7.04 Imp.qts.
----------	---------------------	--------------------------------------

### ■ IMPORTANT

- Use **KUBOTA SUPER UDT fluid or SAE 80, 90 gear oil.**
- Refer to “**LUBRICANTS, FUEL AND COOLING WATER**”.
- (See page AG-1.)

(1) Drain Plug

(2) Filling Port Plug

12191S60040

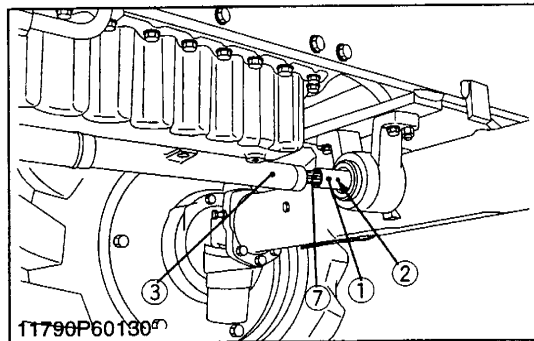

### Propeller Shaft (4WD Only)

1. Slide the propeller shaft cover (3), (5) after removing the screws (6).
2. Tap out the spring pin (2), (4) and then slide the coupling (1), (8) to the front and rear.

### (When reassembling)

- Apply grease to the splines of the propeller shaft (7).

(1) Coupling

(5) Propeller Shaft Cover

(2) Spring Pin

(6) Screw

(3) Propeller Shaft Cover

(7) Propeller Shaft

(4) Spring Pin

(8) Coupling

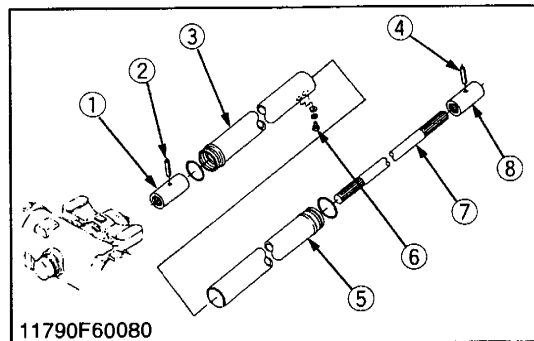

11790S60140

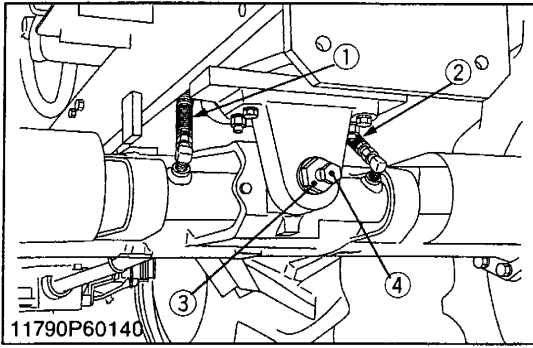

**Power Steering Hoses**

1. Disconnect the power steering hoses (1), (2) from steering cylinder.
2. Remove the cylinder cover.

**(When reassembling)**

Tightening torque	Power steering hose retaining nut	24.5 to 29.4 N-m 2.5 to 3.0 kgf-m 18.1 to 21.7 ft-lbs
	Cylinder cover	60.8 to 70.6 N-m 6.2 to 7.2 kgf-m 44.8 to 52.1 ft-lbs

- (1) Power Steering Hose 1                      (3) Lock Nut  
(2) Power Steering Hose 2                      (4) Adjusting Bolt

11790S60150

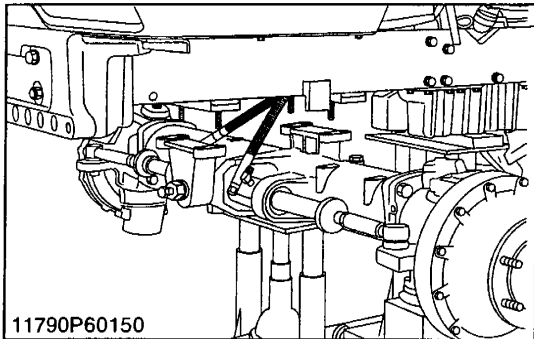

**Front Wheel and Front Axle**

1. Check the front axle and engine are securely mounted on the disassembly stand.
2. Loosen the front wheel mounting nuts.
3. Lift the front axle and remove the front wheels.
4. Loosen the lock nut (3) and adjusting screw (4).
5. Remove the bracket (front) mounting screws and nuts.
6. Remove the bracket (rear) mounting screws and nuts.
7. Separate the front axle from front axle bracket.

**(When reassembling)**

Tightening torque	Front wheel mounting nut	166.7 to 196.1 N-m 17.0 to 20.0 kgf-m 122.9 to 144.6 ft-lbs
	Bracket mounting screw and nut	77.5 to 90.1 N-m 7.9 to 9.2 kgf-m 57.2 to 66.5 ft-lbs

**■ IMPORTANT**

- Be sure to adjust the front axle rocking force. (See page A6-S5)

11790S60160

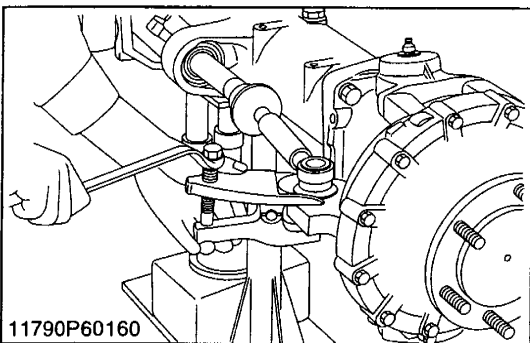

**Tie-rods**

1. Pull out the cotter pin and remove the tie-rod end slotted nuts.
2. Remove the tie-rod with a tie-rod end lifter (Code No. 07909-39051).

**(When reassembling)**

- After tightening the tie-rod end nut to the specified torques, install a cotter pin as shown in the figure left.

Tightening torque	Tie-rod end nut	156.9 to 176.5 N-m 16.0 to 18.0 kgf-m 115.7 to 130.2 ft-lbs
-------------------	-----------------	---

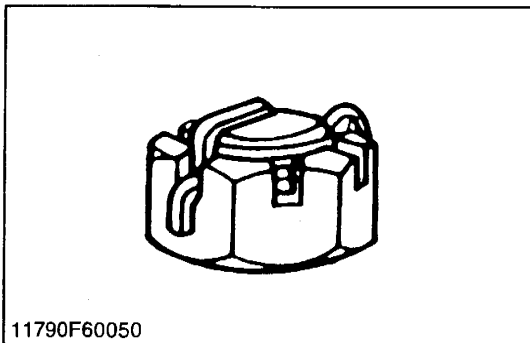

11790S60170

**(2) Disassembling Front Axle [4WD Type]**

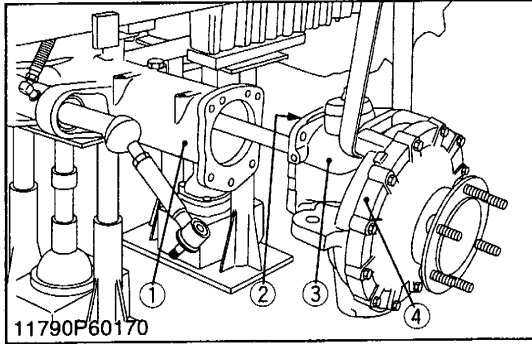

**Bevel Gear Case and Front Gear Case**

1. Remove the bevel gear case mounting screws.
2. Remove the bevel gear case (3) and front gear case (4) as a unit from the front axle case (1).

**(When reassembling)**

- Apply grease to the O-ring (2) and take care not to damage it.
- Do not interchange right and left bevel gear case assemblies.

Tightening torque	Bevel gear case mounting screw	166.7 to 196.1 N·m 17.0 to 20.0 kgf·m 122.9 to 144.6 ft·lbs
-------------------	--------------------------------	---

- (1) Front Axle Case (2) O-ring (3) Bevel Gear Case (4) Front Gear Case

11790S60180

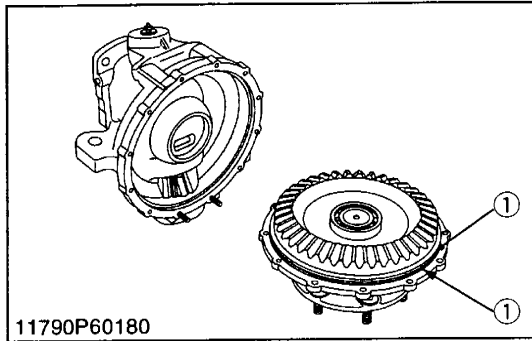

**Axle Flange and Front Gear Case**

1. Remove the axle flange mounting screws.
2. Remove the axle flange (1).

**(When reassembling)**

- Apply grease to the O-ring (2) of axle flange.
- Tighten the axle flange mounting screws and nuts diagonally in several steps.

Tightening torque	Axle flange mounting screw	29.4 to 34.3 N·m 3.0 to 3.5 kgf·m 21.7 to 25.3 ft·lbs
-------------------	----------------------------	---

- (1) Axle Flange (2) O-ring

11790S60190

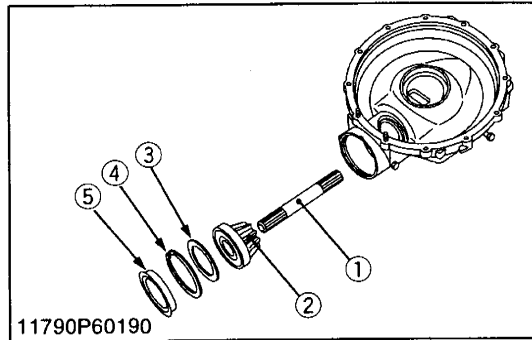

**Bevel Gear and Bevel Gear Shaft**

1. Remove the plug (5).
2. Remove the internal snap ring (4) and shim (3).
3. Tap out the bevel gear (2) with ball bearing.
4. Draw out the bevel gear shaft (1).

- (1) Bevel Gear Shaft (2) Bevel Gear (3) Shim (4) Internal Snap Ring (5) Plug

11790S60200

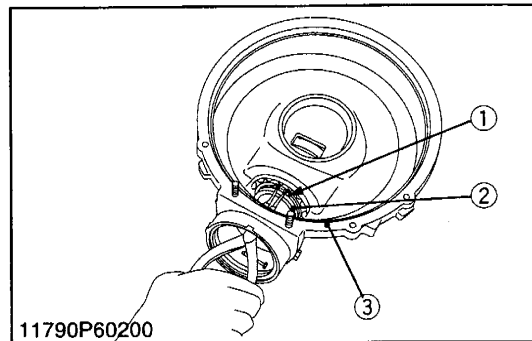

**Bevel Gear Case**

1. Remove the external snap ring (1).
2. Tap the bevel gear case (2) and separate it from the front gear case (3).

- (1) External Snap Ring (2) Bevel Gear Case (3) Front Gear Case

11790S60210

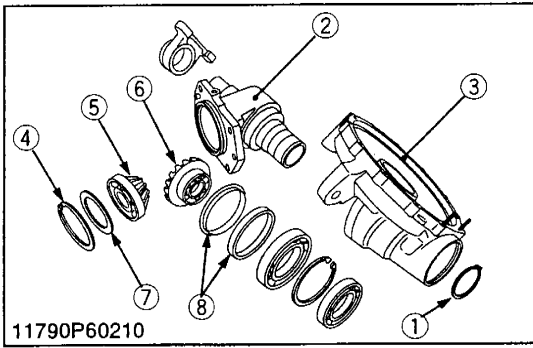

**Bevel Gear Case Gears**

1. Remove the internal snap ring (4).
2. Take out the bevel gears (5), (6) with ball bearings, and shims (7).

**(When reassembling)**

- Install the shims (7) to their original position.
- Install the oil seal (8) of bevel gear case, noting its direction.

- |                        |                |
|------------------------|----------------|
| (1) External Snap Ring | (5) Bevel Gear |
| (2) Bevel Gear Case    | (6) Bevel Gear |
| (3) Front Gear Case    | (7) Shim       |
| (4) Internal Snap Ring | (8) Oil Seal   |

11790S60220

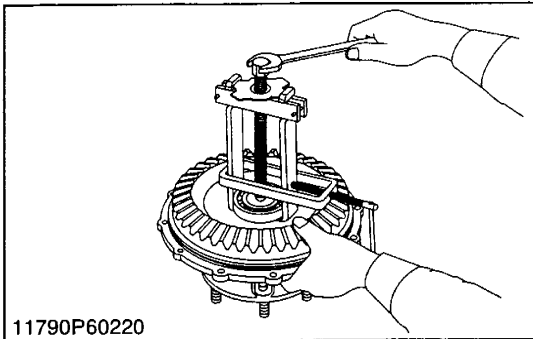

**Axle**

1. Remove the bearing with a special use puller set (Code No. 07916-09032).
2. Take out the bevel gear (2).
3. Take out the collar (1).
4. Tap out the axle (3).

**(When reassembling)**

- Install the oil seal (5) of axle flange (4), noting its direction as shown in the figure below.

- |                |                 |
|----------------|-----------------|
| (1) Collar     | (4) Axle Flange |
| (2) Bevel Gear | (5) Oil Seal    |
| (3) Axle       |                 |

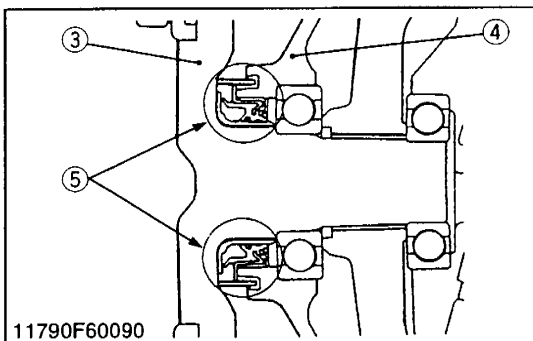
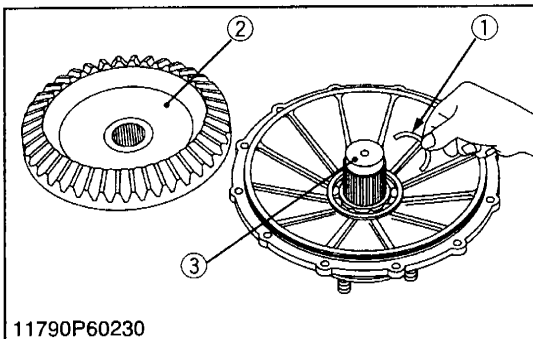

11790S60230

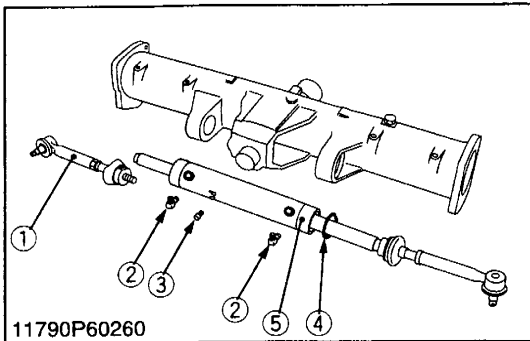
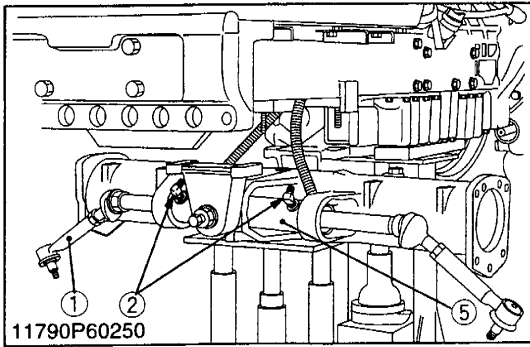

### Steering Cylinder

1. Remove the tie-rod joint (1) (right side).
2. Remove the cylinder set screw (3).
3. Remove the nipples (2) from steering cylinder.
4. Remove the internal snap ring (4).
5. Draw out the steering cylinder (5).

#### (When reassembling)

- Apply liquid lock (Three Bond 1372 or equivalent) to the tie-rod joint.

Tightening torque	Tie-rod joint and steering cylinder mounting screw	166.7 to 196.1 N·m 17.0 to 20.0 kgf·m 122.9 to 144.6 ft·lbs
-------------------	--	---

- |                        |                        |
|------------------------|------------------------|
| (1) Tie-rod Joint      | (4) Internal Snap Ring |
| (2) Nipple             | (5) Steering Cylinder  |
| (3) Cylinder Set Screw |                        |

11790S60241



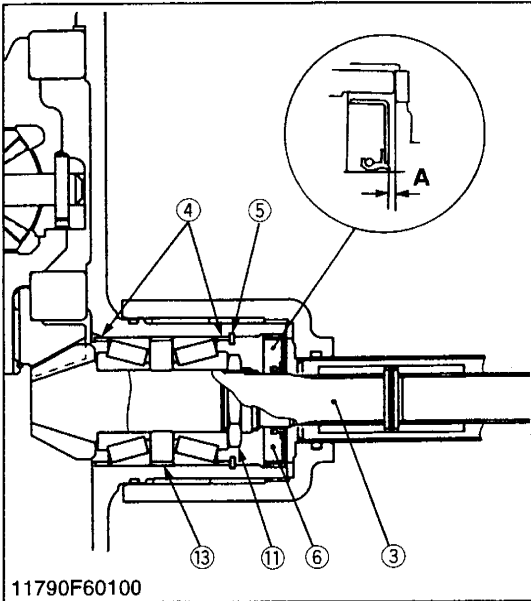
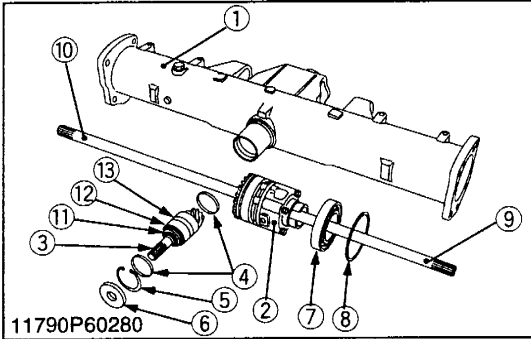
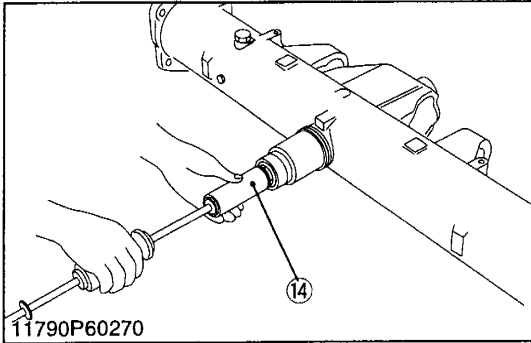

**Spiral Bevel Pinion Shaft and Differential Gear Assembly**

1. Take out the differential yoke shaft (9), (10) both sides.
2. Remove the oil seal (6) and internal snap ring (5).
3. Remove the collar (4).
4. Remove the spiral bevel pinion shaft (3) by the pinion shaft remover (14).
5. Take out the differential gear assembly (2), ball bearing (7) and shim (8) from left side of front axle case (1).
6. Remove the stake of lock nut (11), and then remove the lock nut (11).
7. Remove the taper roller bearings (12).

**(When reassembling)**

- Replace the lock nut (11) and oil seal (6) with new ones.
- Apply grease to the oil seal (6).
- Install the shims and collars to their original position.
- Install the taper roller bearings correctly, noting their direction and apply gear oil to them.
- When press-fitting a oil seal (6), observe the dimension “A” described in the figure.

**■ IMPORTANT**

- **After adjusting the turning torque, stake the lock nut (11) firmly.**

Turning torque of spiral bevel pinion shaft	Factory spec.	0.98 to 1.18 N·m 0.10 to 0.12 kgf·m 0.72 to 0.87 ft-lbs
---	---------------	---

- |  |  |
|--|--|
| <ul style="list-style-type: none"> <li>(1) Front Axle Case</li> <li>(2) Differential Gear Assembly</li> <li>(3) Spiral Bevel Pinion Shaft</li> <li>(4) Adjusting Collar</li> <li>(5) Internal Snap Ring</li> <li>(6) Oil Seal</li> <li>(7) Ball Bearing</li> <li>(8) Shim</li> <li>(9) Differential Yoke Shaft R.H.</li> </ul> | <ul style="list-style-type: none"> <li>(10) Differential Yoke Shaft L.H.</li> <li>(11) Lock Nut</li> <li>(12) Taper Roller Bearing</li> <li>(13) Collar</li> <li>(14) Pinion Shaft Remover</li> </ul> <p><b>(A) Dimension A : 0.5 to 1 mm<br/>(0.020 to 0.039 in.)</b></p> |
|--|--|

11790S60250

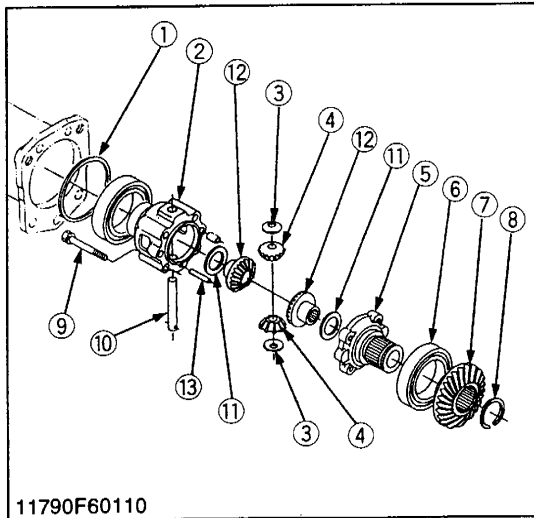

**Differential Gear**

1. Remove the differential case cover mounting screws (9) and then take out the differential case cover (5), ball bearing (6) and spiral bevel gear (7) as a unit.
2. Remove the external snap ring (8), and then remove the ball bearing (6) and spiral bevel gear (7) as a unit with a puller.
3. Remove the straight pin (13).
4. Pull out the pinion shaft (10) and take out the differential pinions (4) and differential side gears (12).

**(When reassembling)**

- Apply molybdenum disulfide (Three Bond 1901 or equivalent) to the inner circumferential surface of the differential side gears (12) and differential pinions (4).

Tightening torque	Differential case cover mounting screw	60.8 to 70.6 N·m 6.2 to 7.2 kgf·m 44.8 to 52.1 ft·lbs
-------------------	--	---

- |                             |  |
|-----------------------------|--|
| (1) Shim                    | (8) External Snap Ring                     |
| (2) Differential Case       | (9) Differential Case Cover Mounting Screw |
| (3) Thrust Collar           | (10) Pinion Shaft                          |
| (4) Differential Pinion     | (11) Shim                                  |
| (5) Differential Case Cover | (12) Differential Side Gear                |
| (6) Ball Bearing            | (13) Straight Pin                          |
| (7) Spiral Bevel Gear       |  |

11790S60260

**SERVICING**

**[4WD Type]**

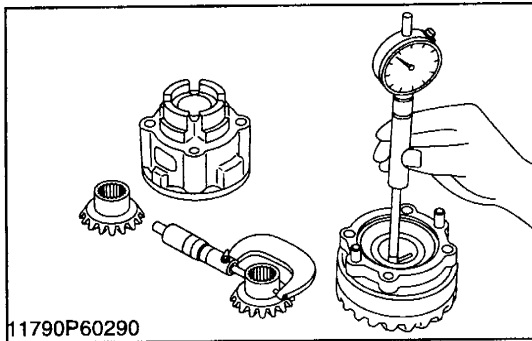

**Clearance between Differential Case (Differential Case Cover) and Differential Side Gear**

1. Measure the differential side gear O.D.
2. Measure the differential case bore I.D. and calculate the clearance.
3. Measure the differential case cover bore I.D. and calculate the clearance.
4. If the clearance exceeds the allowable limit, replace faulty parts.

Clearance between differential case (differential case cover) and differential side gear	Factory spec.	0.040 to 0.123mm 0.00157 to 0.00484 in.
	Allowable limit	0.20 mm 0.0079 in.
Differential case bore I.D.	Factory spec.	32.000 to 32.062 mm 1.25984 to 1.26228 in.
Differential case cover bore I.D.	Factory spec.	32.000 to 32.062 mm 1.25984 to 1.26228 in.
Differential side gear O.D.	Factory spec.	31.939 to 31.960 mm 1.25744 to 1.25827 in.

11790S60270

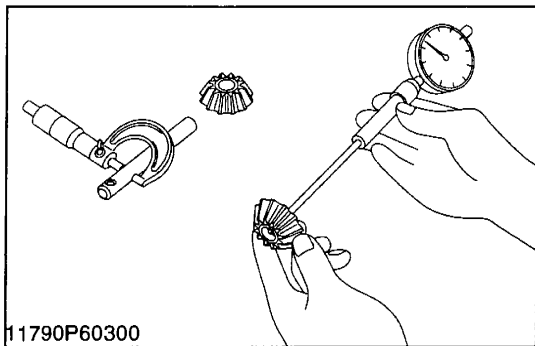

11790P60300

**Clearance between Pinion Shaft and Differential Pinion**

1. Measure the pinion shaft O.D.
2. Measure the differential pinion I.D. and calculate the clearance.
3. If the clearance exceeds the allowable limit, replace faulty parts.

Clearance between pinion shaft and differential pinion	Factory spec.	0.064 to 0.100 mm 0.00252 to 0.00394 in.
	Allowable limit	0.25 mm 0.0096 in.
Pinion shaft O.D.	Factory spec.	13.950 to 13.968 mm 0.54921 to 0.54992 in.
Differential pinion I.D.	Factory spec.	14.032 to 14.050 mm 0.55244 to 0.55315 in.

11790S60280

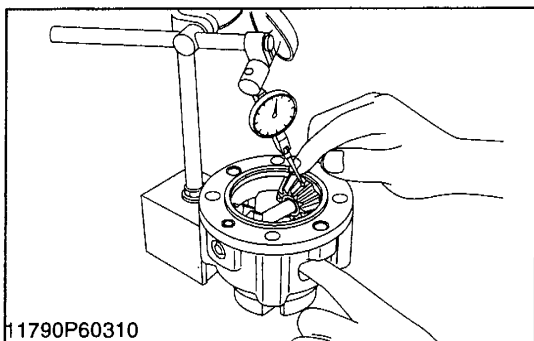

11790P60310

**Backlash between Differential Pinion and Differential Side Gear**

1. Set a dial gauge (lever type) on a tooth of the differential pinion.
2. Fix the differential side gear and move the differential pinion to measure the backlash.
3. If the measurement exceeds the factory specifications, adjust with the differential side gears shims.

Backlash between differential pinion and differential side gear	Factory spec.	0.2 to 0.3 mm 0.008 to 0.012 in.
	Allowable limit	0.4 mm 0.016 in.

**(Reference)**

- Thickness of adjusting shims
 

0.4 mm (0.016 in.)	1.0 mm (0.039 in.)
0.6 mm (0.024 in.)	1.2 mm (0.047 in.)
0.8 mm (0.031 in.)	
- Tooth contact : More than 35 %

11790S60290

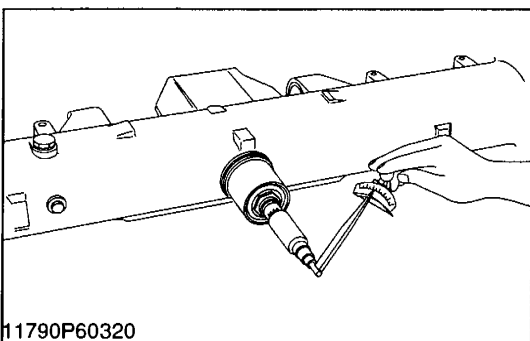

11790P60320

**Turning Torque of Spiral Bevel Pinion Shaft (Pinion Shaft Only)**

1. Install the spiral bevel pinion shaft assembly only to the front axle case.
2. Measure the turning torque of spiral bevel pinion shaft.
3. If the turning torque is not within the factory specifications, adjust with the lock nut.

Turning torque of spiral bevel pinion shaft	Factory spec.	0.98 to 1.18 N·m 0.10 to 0.12 kgf·m 0.72 to 0.87 ft-lbs
---	---------------	---

**NOTE**

- After turning torque adjustment, be sure to stake the lock nut.

11790S60300



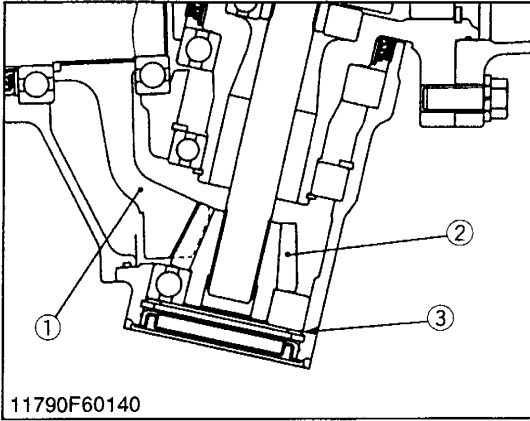

**Backlash between 9T Bevel Gear and 43T Bevel Gear**

1. Stick a strip of fuse to three spots on the 43T bevel gear (1) with grease.
2. Fix the axle flange and front gear case.
3. Turn the axle.
4. Remove the axle flange from front gear case and measure the thickness of the fuse with an outside micrometer.
5. If the backlash is not within the factory specifications, adjust with shim (3).

Backlash between 9T bevel gear and 43T bevel gear	Factory spec.	0.25 to 0.35 mm 0.0098 to 0.0138 in.
	Allowable limit	0.6 mm 0.024 in.

**(Reference)**

- Thickness of adjusting shims (3)
 

0.4 mm (0.016 in.)	1.0 mm (0.039 in.)
0.6 mm (0.024 in.)	1.2 mm (0.047 in.)
0.8 mm (0.031 in.)	
- Tooth contact : More than 35 %

- (1) 43T Bevel Gear
- (2) 9T Bevel Gear
- (3) Shim

11790S60330

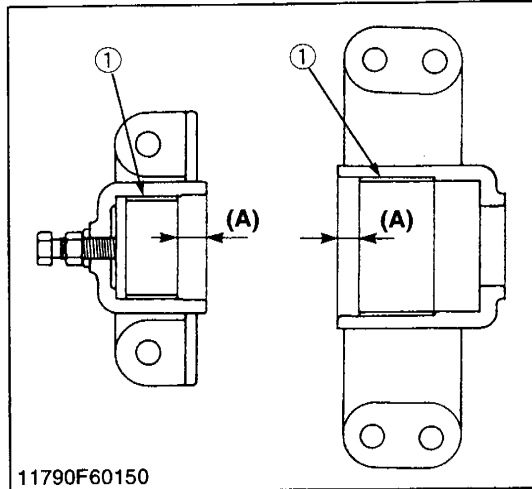
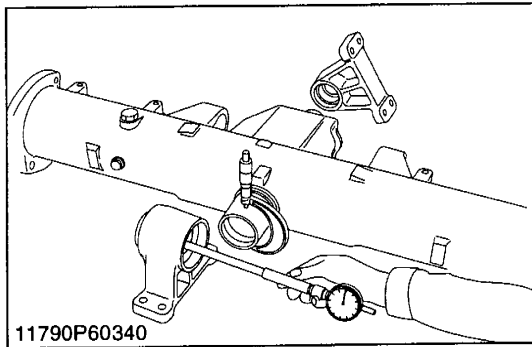

**Clearance between Front Axle Case Bosses and Bracket Bushings**

1. Measure the front axle case bosses O.D. with an outside micrometer.
2. Measure the bracket bushing I.D. and calculate the clearance.
3. If the clearance exceeds the allowable limit, replace the bracket bushing.

Clearance between front axle case boss (front) and bracket bushing (front)	Factory spec.	0.025 to 0.160 mm 0.00098 to 0.00630 in.
	Allowable limit	0.35 mm 0.0138 in.

Front axle case boss (front) O.D.	Factory spec.	49.950 to 49.975 mm 1.96653 to 1.96752 in.
Bracket bushing (front) I.D.	Factory spec.	50.000 to 50.110 mm 1.96850 to 1.97283 in.

Clearance between front axle case boss (rear) and bracket bushing (rear)	Factory spec.	0.025 to 0.190 mm 0.00098 to 0.00748 in.
	Allowable limit	0.35 mm 0.0138 in.

Front axle case boss (rear) O.D.	Factory spec.	70.000 to 70.035 mm 2.75590 to 2.75728 in.
Bracket bushing (rear) I.D.	Factory spec.	70.060 to 70.190 mm 2.75826 to 2.76338 in.

**Press-fitting Bushing**

- When press-fitting a new bushing, observe the dimension described in the figure.

Press-fit depth of bushing (A)	Factory spec.	12.0 to 13.0 mm 0.47 to 0.51 in.
--------------------------------	---------------	-------------------------------------

**NOTE**

- After replacing the bushing, be sure to adjust the front axle rocking force. (See page A6-S5.)

(1) Bushing

12191S60050

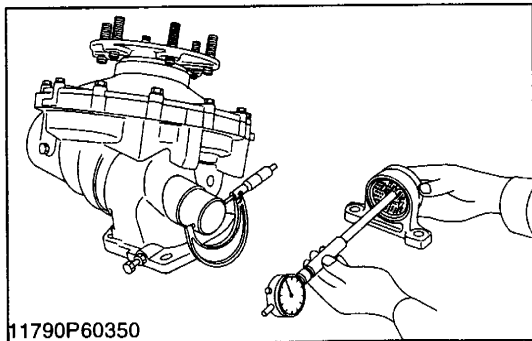

**Clearance between Bevel Gear Case Boss and Front Axle Support Bushing**

1. Measure the bevel gear case boss O.D. with an outside micrometer.
2. Measure the support bushing I.D. and calculate the clearance.
3. If the clearance exceeds the allowable limit, replace it.

Clearance between bevel gear case boss and front axle support bushing	Factory spec.	0.060 to 0.220 mm 0.00236 to 0.00866 in.
	Allowable limit	0.50 mm 0.0197 in.

Bevel gear case boss O.D.	Factory spec.	54.970 to 55.000 mm 2.16417 to 2.16535 in.
Front axle support bushing I.D.	Factory spec.	55.060 to 55.190 mm 2.16772 to 2.17283 in.

11790S60350

## 7 STEERING

### [1] STEERING CYLINDER

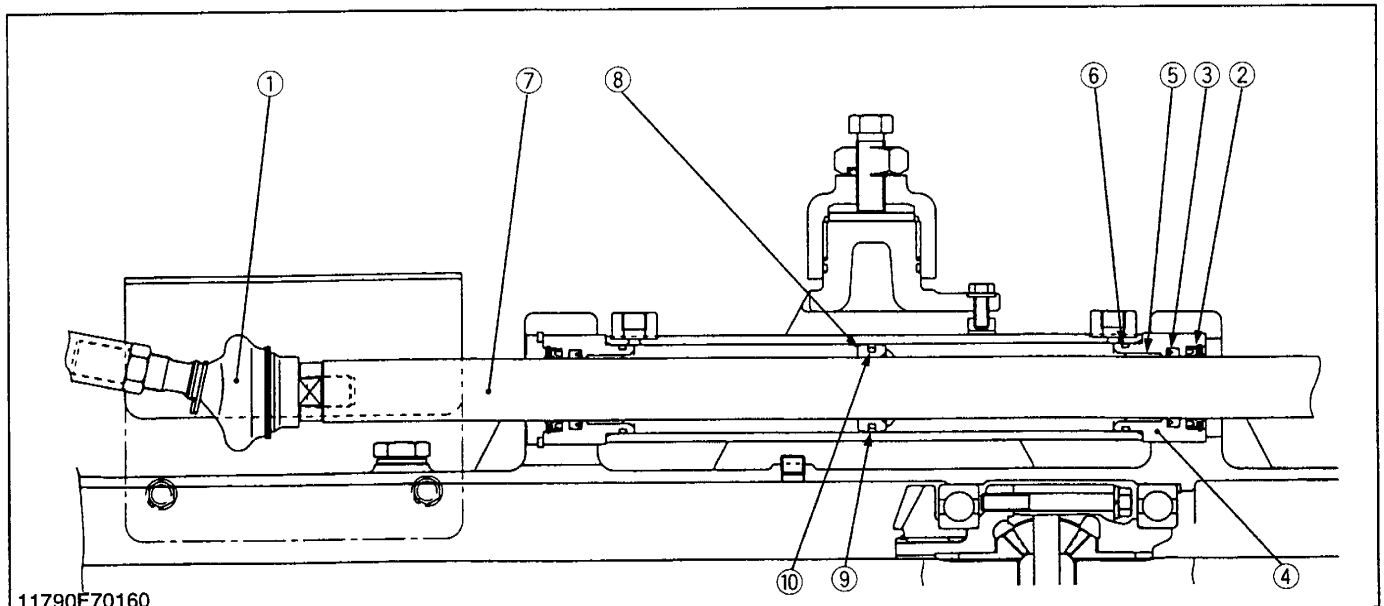

11790F70160

(1) Rubber Boots  
 (2) Scraper Seal  
 (3) Oil Seal

(4) Guide  
 (5) Bushing  
 (6) O-ring

(7) Rod  
 (8) Piston

(9) Slipper Seal  
 (10) O-ring

The steering cylinder is single piston both rod double-acting type. This steering cylinder is installed parallel to the front axle and connected to tie-rods.

The tie-rods connected to both knuckle arm guarantees equal steering movement to both front wheels.

The steering cylinder provide force in both directions. Depending upon direction the steering wheel is turned pressure oil enters at one end of the cylinder to extend, or the other end to retract it, thereby turning front wheel of the tractor.

11790M70130

—— MEMO ——



# SERVICING SPECIFICATIONS

## POWER STEERING HYDRAULIC PUMP

Item		Factory Specification	Allowable Limit
Hydraulic Pump Condition <ul style="list-style-type: none"> <li>• Engine Speed Approx. 2700 rpm</li> <li>• Rated Pressure [4WD] 11.8 to 12.7 MPa 120 to 130 kgf/cm<sup>2</sup> 1707 to 1849 psi</li> <li>• Oil Temperature 40 to 60 °C 104 to 140 °F</li> </ul>	Delivery at No Pressure	Above 18.3 L/min. 4.83 U.S.gal./min. 4.03 Imp.gal./min.	
	Delivery at Rated Pressure	Above 17.6 L/min. 4.65 U.S.gal./min. 3.87 Imp.gal./min.	15.8 L/min. 4.17 U.S.gal./min. 3.48 Imp.gal./min.
Housing	Depth of Scratch	–	0.09 mm 0.0035 in.
Bushing to Gear Shaft	Clearance	–	0.15 mm 0.0059 in.
Bushing	Length	15.79 to 15.80 mm 0.6217 to 0.6220 in.	15.60 mm 0.6142 in.

## STEERING CONTROLLER

Relief Valve Condition <ul style="list-style-type: none"> <li>• Engine Speed Maximum</li> <li>• Oil Temperature 40 to 60 °C 104 to 140 °F</li> </ul>	Setting Pressure [4WD Type]	11.8 to 12.7 MPa 120 to 130 kgf/cm <sup>2</sup> 1707 to 1849 psi	–
Rotor Set	Clearance	–	0.08 mm 0.0031 in.

12191S70010

## STEERING CYLINDER

Item		Factory Specification	Allowable Limit
Steering Cylinder	I.D.	50.000 to 50.062 mm 1.96850 to 1.97094 in.	50.100 mm 1.97244 in.
Rod to Bushing	Clearance	0.009 to 0.127 mm 0.00035 to 0.00500 in.	0.135 mm 0.00531 in.

11790S70330

# TIGHTENING TORQUES

Tightening torques of screws, and nuts on the table below are especially specified.  
(For general use screws, and nuts : See page G-9.)

Item	N·m	kgf·m	ft-lbs
Delivery pipe joint bolt (Power steering hydraulic pump to regulator valve)	39.3 to 49.0	4.0 to 5.0	29.0 to 36.2
GST-independent PTO delivery pipe joint bolt	34.3 to 39.2	3.5 to 4.0	25.3 to 28.9
Power steering delivery hose joint bolt	49.0 to 58.8	5.0 to 6.0	36.2 to 43.4
Regulator valve mounting screws	17.6 to 20.6	1.8 to 2.1	13.0 to 15.2
Hydraulic pump assembly mounting screw and nut	23.6 to 27.4	2.4 to 2.8	17.4 to 20.2
Main delivery hose retaining nut	46.6 to 50.9	4.8 to 5.2	34.4 to 37.6
Turning delivery hose retaining nut	24.5 to 29.4	2.5 to 3.0	18.1 to 21.7
Steering controller mounting nuts	23.5 to 27.5	2.4 2.8	17.4 to 20.3
Steering controller retaining nuts	23.5 to 27.5	2.4 to 2.8	17.4 to 20.3
Gerotor assembly hex. socket head cap screws	1.24 to 1.47	0.13 to 0.15	0.94 to 1.08
Tie-rod end nut [4WD Type]	156.9 to 176.5	16.0 18.0	115.7 to 130.2
Tie-rod joint and steering cylinder mounting screw	166.6 to 196.0	17.0 to 20.0	122.9 to 144.6
Steering cylinder mounting nut	39.2 to 45.1	4.0 to 4.6	28.9 to 33.3
Guide assembly	181.4 to 289.3	18.5 to 29.5	133.8 to 213.4
Cylinder cover	60.8 to 70.6	6.2 to 7.2	44.9 to 52.1
Tie-rod joint and steering cylinder	166.6 to 196.0	17.0 to 20.0	122.9 to 144.6

12191S70020

## CHECKING, DISASSEMBLING AND SERVICING

### [1] POWER STEERING HYDRAULIC PUMP

#### CHECKING

##### (1) Pump Test Using Flow-meter

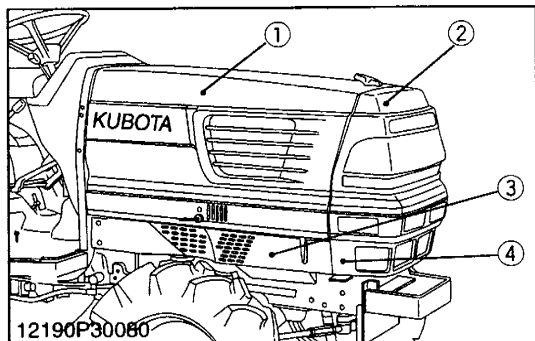

#### Preparation

1. Remove the side cover RH (1) and front mask (2)
2. Remove the front grille (3) and side skirt RH (4)
3. Remove the delivery pipe (5) between the regulator valve (6) and power steering hydraulic pump (7)

#### (When reassembling)

- Install the copper washers (8) firmly.
- Apply grease to the O-ring (9) and take care not to damage it.

Tightening torque	Delivery pipe joint bolt	39.3 to 49.0 N·m 4.0 to 5.0 kgf·m 29.0 to 36.2 ft-lbs
-------------------	--------------------------	---

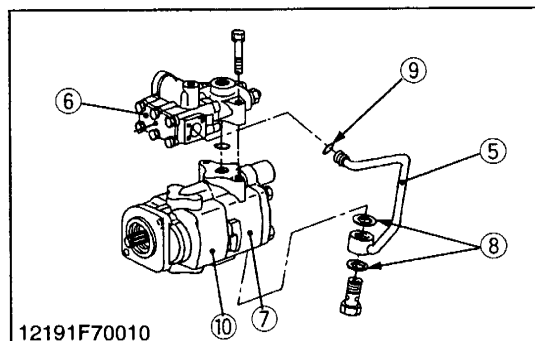

- |                   |  |
|-------------------|--|
| (1) Side Cover RH | (6) Regulator Valve                    |
| (2) Front Mask    | (7) Power Steering Hydraulic Pump      |
| (3) Front Grille  | (8) Copper Washers                     |
| (4) Side Skirt RH | (9) O-ring                             |
| (5) Delivery Pipe | (10) Three Point System Hydraulic Pump |

12191S70030

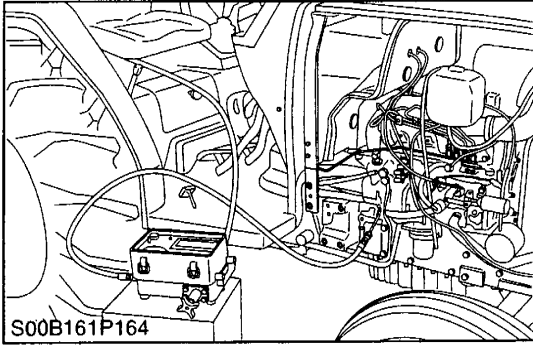

**Hydraulic Flow Test**

■ **IMPORTANT**

- When using a flowmeter other than KUBOTA specified flowmeter, be sure to use the instructions with that flowmeter.
- Do not close the flowmeter loading valve completely, before testing, because it has no relief valve.

1. Install the adaptor 69 (PF 3/8) and adaptor 66 to the pump discharge port.
2. Connect the hydraulic test hose to the adaptor 66 and flowmeter inlet port.
3. Connect the other hydraulic test hose to the flowmeter outlet port and to transmission fluid filling plug hole.
4. Open the flowmeter loading valve completely. (Turn counterclockwise.)
5. Start the engine and set the engine speed at **2000 to 2200 rpm**.
6. Slowly close the loading valve to generate pressure approx. **9.8 MPa (100 kgf/cm<sup>2</sup>, 1422 psi)**. Hold in this condition until oil temperature reaches approx. 40 °C (104 °F).
7. Open the loading valve completely.
8. Set the engine speed. (Refer to **Condition**.)
9. Read and note the pump delivery at no pressure.
10. Slowly close the loading valve to increase rated pressure. (Refer to **Condition**.) As the load is increased, engine speed drops, therefore, reset the engine speed.
11. Read and note the pump delivery at rated pressure.
12. Open the loading valve completely and stop the engine.
13. If the pump delivery does not reach the allowable limit, check the pump suction line, oil filter or hydraulic pump.

**Condition**

- Engine speed  
Approx. 2700 rpm
- Rated pressure  
[4WD Type]..... 11.8 to 12.7 MPa  
120 to 130 kgf/cm<sup>2</sup>  
1707 to 1849 psi
- Oil temperature ..... 40 to 60 °C  
104 to 140 °F

Hydraulic pump delivery at no pressure	Factory spec.	Above 18.3 L/min 4.83 U.S. gal/min 4.03 Imp.gal/min
Hydraulic pump delivery at rated pressure	Factory spec.	Above 17.6 L/min 4.65 U.S. gal/min 3.87 Imp.gal/min
	Allowable limit	15.8 L/min 4.17 U.S. gal/min 3.48 Imp.gal/min

12191S70040

## [2] RELIEF VALVE CHECKING

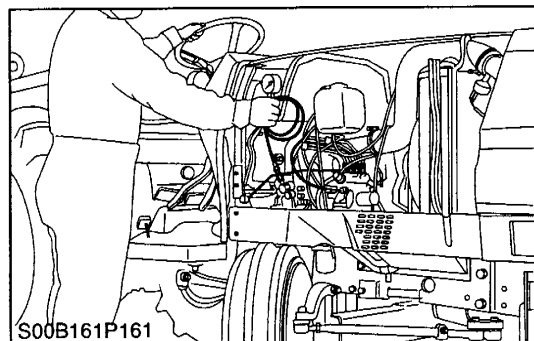
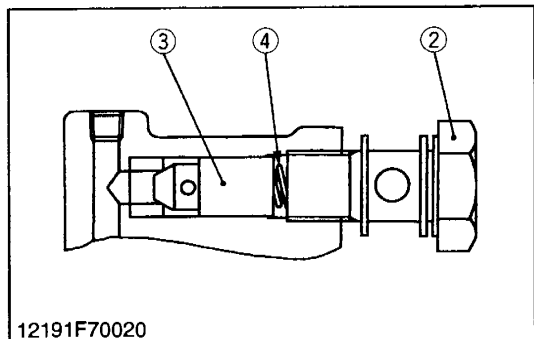
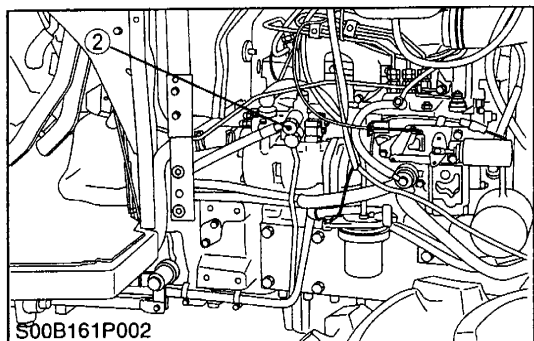
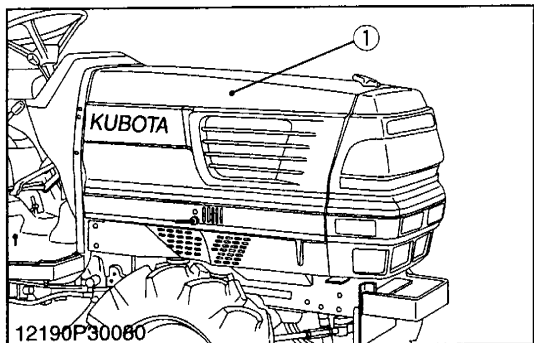

### Relief Valve Setting Pressure Test

1. Remove the side cover RH (1).
2. Disconnect the delivery hose joint bolt (2) which connects delivery hose and regulator valve.
3. Take out the spring (4) and check valve (3).
4. Install the adaptor E and adaptor 58 of relief valve setting pressure tester to the regulator valve, and then set a thread joint, cable and pressure gauge.
5. Start the engine and set the engine speed at max. speed.
6. Fully turn the steering wheel to the left or right and read the pressure when the relief valve functions.
7. Stop the engine.
8. If the pressure is not within the factory specifications, check the pump delivery line, replace the relief valve assembly or repair the power steering.

Power steering relief valve setting pressure	Factory spec. [4WD]	11.8 to 12.7 MPa 120 to 130 kgf/cm <sup>2</sup> 1707 to 1849 psi
--	---------------------	--

### (When reassembling)

- Install the spring (4) and check valve (3) firmly.
- Install the copper washers firmly.

Tightening torque	Power steering delivery hose joint bolt	49.0 to 58.8 N·m 5.0 to 6.0 kgf·m 36.2 to 43.4ft·lbs
-------------------	---	--

### Condition

- Engine speed ..... Maximum
- Oil temperature ..... 40 to 60 °C

- |                              |                 |
|------------------------------|-----------------|
| (1) Side Cover RH            | (3) Check Valve |
| (2) Delivery Hose Joint Bolt | (4) Spring      |

12191S70050

### [3] STEERING CYLINDER DISASSEMBLING AND ASSEMBLING

[4WD Type]

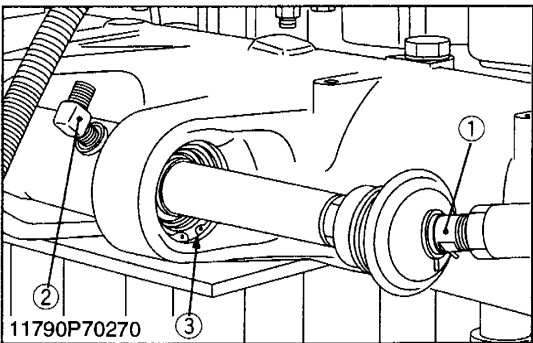
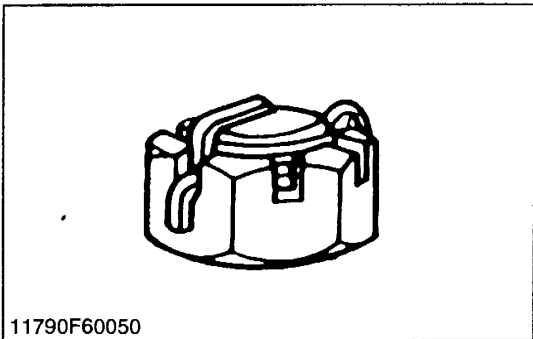
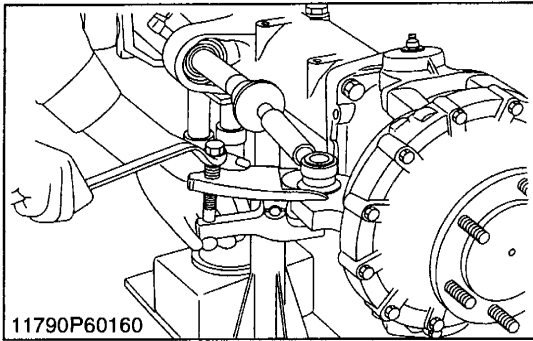
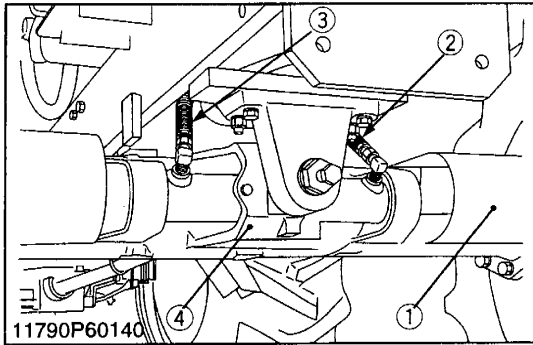

**Tie-rod**

1. Remove the cylinder cover (1).
2. Disconnect the power steering hoses (2), (3) from cylinder.
3. Remove the set screw (4).
4. Place a disassembly stand under the engine and support it with a jack.
5. Pull out the cotter pin and remove the tie-rod end nuts.
6. Remove the tie-rod with a tie-rod end lifter (Code No. 07909-39051).

**(When reassembling)**

- After tightening the tie-rod end nut to the specified torque, install a cotter pin as shown in the figure left.

Tightening torque	Tie-rod end nut	156.9 to 176.5 N·m 16.0 to 18.0 kgf·m 115.7 to 130.2 ft-lbs
	Cylinder cover	60.8 to 70.6 N·m 6.2 to 7.2 kgf·m 44.9 to 52.1 ft-lbs

- |                         |                         |
|-------------------------|-------------------------|
| (1) Cylinder Cover      | (3) Power Steering Hose |
| (2) Power Steering Hose | (4) Set Screw           |

11790S70250

**Steering Cylinder**

1. Remove the tie-rod joint (1) (right and left).
2. Remove the nipples (2) from steering cylinder.
3. Remove the internal snap ring (3).
4. Draw out the steering cylinder to the left.

**(When reassembling)**

- Apply liquid lock (Three Bond 1372 or equivalent) to the tie-rod joint.

Tightening torque	Tie-rod joint and steering cylinder	166.6 to 196.0 N·m 17.0 to 20.0 kgf·m 122.9 to 144.6 ft-lbs
-------------------	-------------------------------------	---

- |                   |                        |
|-------------------|------------------------|
| (1) Tie-rod Joint | (3) Internal Snap Ring |
| (2) Nipple        |                        |

11790S70261

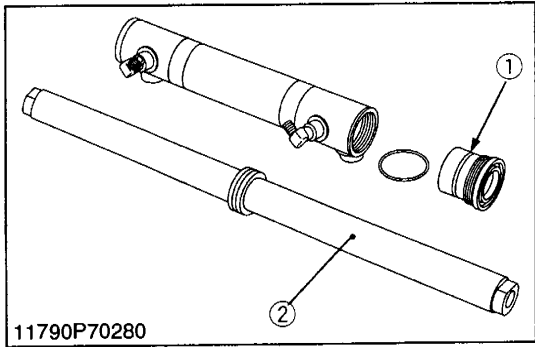

11790P70280

**Disassembling Steering Cylinder**

1. Remove the guide assembly (1) and draw out the piston rod (2).

**(When reassembling)**

- Apply transmission fluid to the oil seal and O-ring.

- (1) Guide Assembly (2) Piston Rod

11790S70270

**SERVICING**

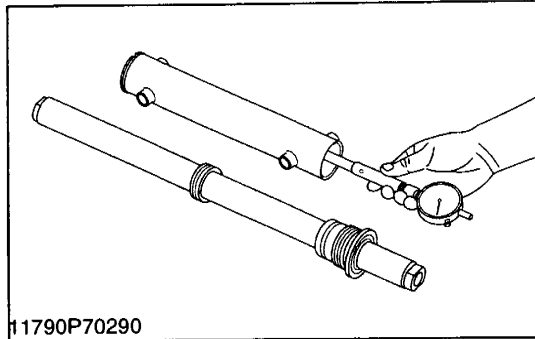

11790P70290

**Steering Cylinder I.D.**

1. Measure the steering cylinder I.D. with a cylinder gauge.
2. If the cylinder I.D. exceed the allowable limit, replace the cylinder barrel.

Steering cylinder I.D.	Factory spec.	50.000 to 50.062 mm 1.96850 to 1.97094 in.
	Allowable limit	50.100 mm 1.97244 in.

11790S70280

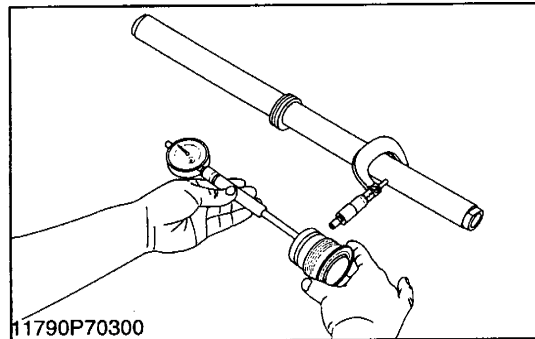

11790P70300

**Clearance between Rod and Bushing**

1. Measure the bushing I.D. with a cylinder gauge.
2. Measure the rod O.D. with a outside micrometer, and calculate the clearance.
3. If the clearance exceeds the allowable limit, replace as a unit.

Clearance between rod and bushing	Factory spec.	0.009 to 0.127 mm 0.00035 to 0.00500 in.
	Allowable limit	0.135 mm 0.00531 in.

11790S70290

## 8 HYDRAULIC SYSTEM

### SERVICING SPECIFICATIONS

#### POWER STEERING HYDRAULIC PUMP

Item		Factory Specification	Allowable Limit
Hydraulic Pump Condition <ul style="list-style-type: none"> <li>● Engine Speed Approx. 2700 rpm</li> <li>● Rated Pressure 16.2 to 17.7 MPa 165 to 180 kgf/cm<sup>2</sup> 2347 to 2560 psi</li> <li>● Oil Temperature 40 to 60 °C 104 to 140 °F</li> </ul>	Delivery at No Pressure	Above 36.4 L/min. 9.62 U.S.gal./min. 8.01 Imp.gal./min.	—
	Delivery at Rated Pressure	Above 34.9 L/min. 9.22 U.S.gal./min. 7.68 Imp.gal./min.	31.4 L/min. 8.30 U.S.gal./min. 6.91 Imp.gal./min.
Housing	Depth of Scratch	—	0.09 mm 0.0035 in.
Bushing to Gear Shaft	Clearance	—	0.12 mm 0.0043 in.
Bushing	Length	20.49 to 20.50 mm 0.8067 to 0.807 in.	20.30 mm 0.7992 in.

#### RELIEF VALVE

<b>Relief Valve</b> Condition <ul style="list-style-type: none"> <li>● Engine Speed Maximum</li> <li>● Oil Temperature 40 to 60 °C 104 to 140 °F</li> </ul>	Setting Pressure	16.2 to 17.7 MPa 165 to 180 kgf/cm <sup>2</sup> 2347 to 2560 psi	—
--	------------------	--	---

#### CONTROL LINKAGE

Lift Arm	Free Play (at Maximum Raising Position)	10 to 15 mm 0.39 to 0.59 in.	—
----------	--	---------------------------------	---

12191S80010

# CHECKING, DISASSEMBLING AND SERVICING

## [1] HYDRAULIC PUMP

### CHECKING

#### (1) Pump Test Using Flow-meter

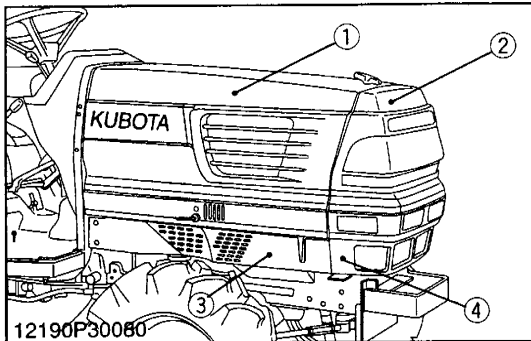

#### Preparation

1. Remove the side cover RH (1) and front mask (2).
2. Remove the front grille (3) and side skirt RH (4).
3. Remove the delivery pipe (5) between the three point system hydraulic pump (6) and front hydraulic block (7).

#### (When reassembling)

- Install the copper washers (8) and O-ring (9) firmly.

Tightening torque	Delivery pipe joint bolt	49.0 to 58.8 N·m 5.0 to 6.0 kgf·m 36.2 to 43.4 ft-lbs
-------------------	--------------------------	---

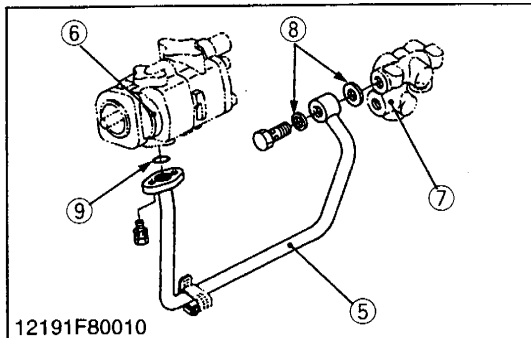

- (1) Side Cover RH
- (2) Front Mask
- (3) Front Grille
- (4) Side Skirt RH
- (5) Delivery Pipe

- (6) Three Point System Hydraulic Pump
- (7) Front Hydraulic Block
- (8) Copper Washers
- (9) O-ring

12191S80020



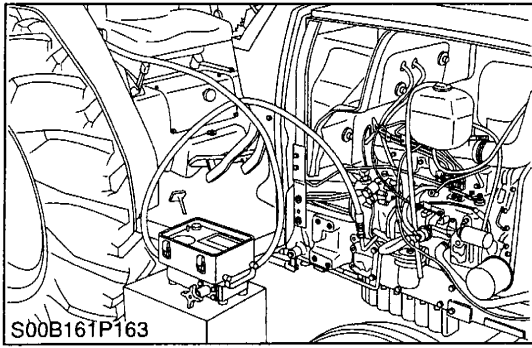

**Condition**

- Engine speed  
Approx. 2700 rpm
- Rated pressure  
..... 16.2 to 17.7 MPa  
165 to 180 kgf/cm<sup>2</sup>  
2347 to 2560 psi
- Oil temperature ..... 40 to 60 °C  
104 to 140 °F

**Hydraulic Flow Test**

■ **IMPORTANT**

- When using a flowmeter other than KUBOTA specified flowmeter, be sure to use the instructions with that flowmeter.
  - Do not close the flowmeter loading valve completely, before testing, because it has no relief valve.
1. Install the adaptor 61 with O-ring to the pump discharge port.
  2. Connect the hydraulic test hose to the adaptor 61 and flowmeter inlet port.
  3. Connect the other hydraulic test hose to the flowmeter outlet port and to transmission fluid filling plug hole.
  4. Open the flowmeter loading valve completely. (Turn counterclockwise.)
  5. Start the engine and set the engine speed at **2000 to 2200 rpm**.
  6. Slowly close the loading valve to generate pressure approx. **14.7 MPa (150 kgf/cm<sup>2</sup>, 2133 psi)**. Hold in this condition until oil temperature reaches approx. **40 °C (104 °F)**.
  7. Open the loading valve completely.
  8. Set the engine speed. (Refer to **Condition**.)
  9. Read and note the pump delivery at no pressure.
  10. Slowly close the loading valve to increase pressure approx. **17.16 MPa (175 kgf/cm<sup>2</sup>, 2489 psi)**. As the load is increased, engine speed drops, therefore, reset the engine speed.
  11. Read and note the pump delivery at rated pressure.
  12. Open the loading valve completely and stop the engine.
  13. If the pump delivery does not reach the allowable limit, check the pump suction line, oil filter or hydraulic pump.

Hydraulic pump delivery at no pressure	Factory spec.	Above 36.4 L/min 9.62 U.S. gal/min 8.01 Imp.gal/min
	Factory spec.	Above 34.9 L/min 9.22 U.S. gal/min 7.68 Imp.gal/min
Hydraulic pump delivery at rated pressure	Allowable limit	31.4 L/min 8.30 U.S. gal/min 6.91 Imp.gal/min

12191S80030

# 9 ELECTRICAL SYSTEM

## [1] STARTING SYSTEM

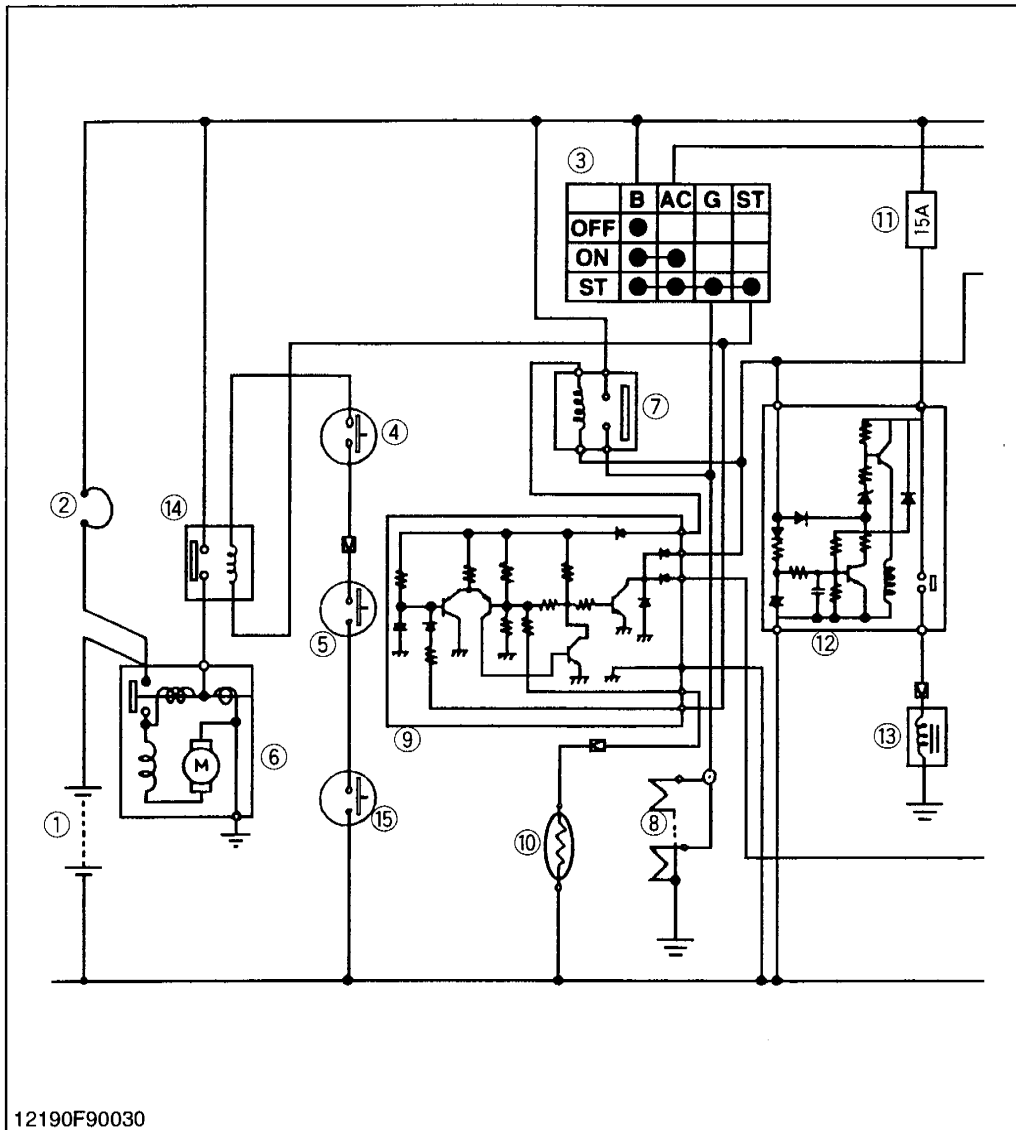

- (1) Battery
- (2) Slow Blow Fuse
- (3) Main Switch
- (4) Shuttle Limit Switch (GST)  
HST Pedal Switch (HST)
- (5) PTO Limit Switch (GST,  
HST)
- (6) Starter Motor
- (7) Glow Relay
- (8) Glow Plug
- (9) Glow Controller
- (10) Water Temperature Sensor  
(for Preheating System)
- (11) Fuse
- (12) Timer Relay
- (13) Key Stop Solenoid
- (14) Starter Relay
- (15) Clutch Pedal Switch (HST)

12190F90030

When the main switch (3) is turned to the **ON** position, the terminal **B** is connected to the terminal **AC** then magnetizes the coil of glow relay (7).

The glow relay (7) is turned **ON**, the glow plugs (8) become red hot, and at the same time, light up the glow lamp on the meter panel.

When the main switch (3) is turned to the **START** position with the shuttle limit switch (4) (Mechanical transmission and GST Mode), HST switch (HST Model),

clutch pedal switch (HST Model) and PTO limit switch (5) **ON**, after the glow lamp is put out light.

The terminal **B** is connected to the terminal **AC**, **ST** and **G** so that the starter motor (6) begins running and the glow plugs (8) are kept red hot.

The main switch (3) automatically returns to the **ON** position when it is released after the engine starts.

At the **ON** position, the starting circuit to be opened, stopping the starter motor (6).

12191M90010

# SERVICING

## [1] STARTING SYSTEM CHECKING

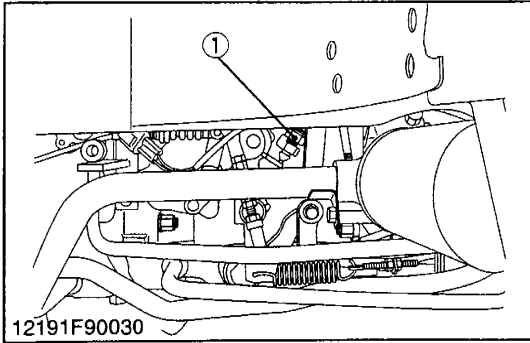

### Checking HST Pedal Switch

1. Disconnect the 2P connector from HST pedal switch.
2. Connect the circuit tester to the 2P connector of switch.
3. Measure the resistance across the terminal 1 and 2.
4. If the HST pedal switch is defective, replace it.

Resistance (Across switch terminal)	When the HST pedal is in neutral position	0 ohm
	When the HST pedal is in other position	Infinity

(1) HST Pedal Switch

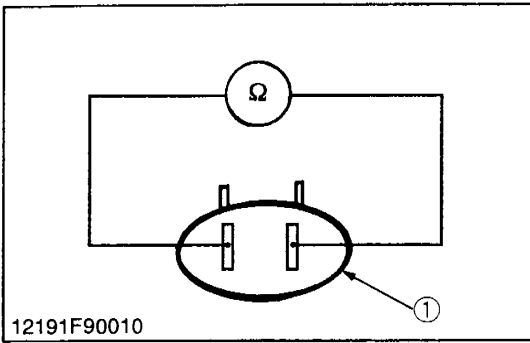

12191S90010

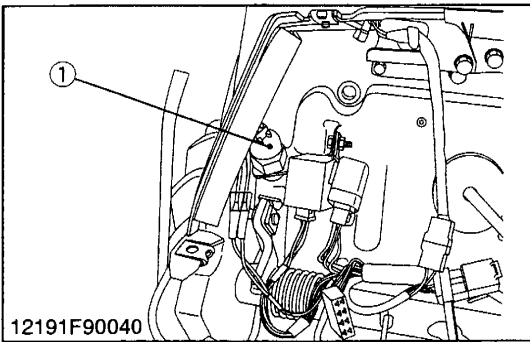

### Checking Clutch Pedal Switch

1. Disconnect the leads from clutch pedal switch.
2. Connect the circuit tester to the switch leads.
3. Measure the resistance between leads.
4. If the clutch pedal switch is defective, replace it.

Resistance (Across switch terminal)	When switch push is pushed	0 ohm
	When switch push is released	Infinity

(1) Clutch Pedal Switch

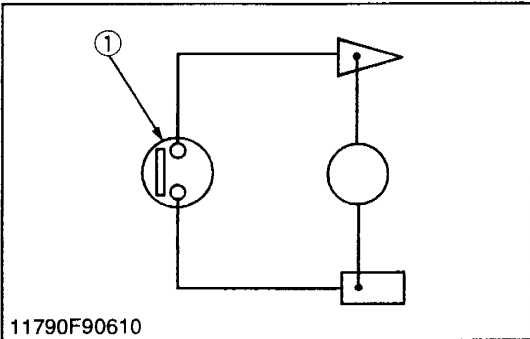

12191S90020

