

OPERATOR'S MANUAL

KUBOTA TRACTOR

MODEL L35



F-7768

READ AND SAVE THIS MANUAL

Kubota

ABBREVIATION LIST

Abbreviations	Definitions
2WD	Two Wheel Drive
4WD	Four Wheel Drive
API	American Petroleum Institute
ASAE	American Society of Agricultural Engineers, USA
ASTM	American Society for Testing and Materials, USA
DIN	Deutsches Institut für Normung, GERMANY
DT	Dual Traction [4WD]
fpm	Feet Per Minute
GST	Glide Shift Transmission
Hi-Lo	High Speed-Low Speed
HST	Hydrostatic Transmission
m/s	Meters Per Second
PTO	Power Take Off
RH/LH	Right-hand and left-hand sides are determined by facing in the direction of forward travel
ROPS	Roll-Over Protective Structures
rpm	Revolutions Per Minute
r/s	Revolutions Per Second
SAE	Society of Automotive Engineers, USA
SMV	Slow Moving Vehicle

California Proposition 65

▲ WARNING ▲

The engine exhaust from this product contains chemicals known to the State of California to cause cancer, birth defects or other reproductive harm.

UNIVERSAL SYMBOLS

As a guide to the operation of your tractor, various universal symbols have been utilized on the instruments and controls. The symbols are shown below with an indication of their meaning.

	Safety Alert Symbol		Remote Cylinder-Retract
	Diesel Fuel		Remote Cylinder-Extend
	Fuel-Level		Steering Wheel-Tilt Control
	Engine-Rotational Speed		Hazard Warning Lights
	Hourmeter/Elapsed Operating Hours		Headlight-Low Beam
	Engine Coolant-Temperature		Headlight-High Beam
	Diesel Preheat/Glow Plugs(Low Temperature Start Aid)		Four-Wheel Drive-On
	Parking Brake		Four-Wheel Drive-Off
	Engine Intake/Combustion Air-Filter		Fast
	Battery Charging Condition		Slow
	Engine Oil-Pressure		Creep
	Turn Signal		Read Operator's Manual
	Engine-Stop		Tractor-Forward Movement-Overhead View of Machine
	Engine Shut-Off Control		Tractor-Rearward Movement-Overhead View of Machine
	Engine-Run		Engine Speed Control
	Starter Control		
	Power Take-Off Clutch Control-Off Position		
	Power Take-Off Clutch Control-On Position		
	Differential Lock		
	Position Control-Raised Position		
	Position Control-Lowered Position		
	Draft Control-Shallow Position		
	Draft Control-Deep Position		
	3-Point Lowering Speed Control		

FOREWORD

You are now the proud owner of a KUBOTA Tractor. This tractor is a product of KUBOTA quality engineering and manufacturing. It is made of fine materials and under a rigid quality control system. It will give you long, satisfactory service. To obtain the best use of your tractor, please read this manual carefully. It will help you become familiar with the operation of the tractor and contains many helpful hints about tractor maintenance. It is KUBOTA's policy to utilize as quickly as possible every advance in our research. The immediate use of new techniques in the manufacture of products may cause some small parts of this manual to be outdated. KUBOTA distributors and dealers will have the most up-to-date information. Please do not hesitate to consult with them.



SAFETY FIRST

This symbol, the industry's "Safety Alert Symbol", is used throughout this manual and on labels on the machine itself to warn of the possibility of personal injury. Read these instructions carefully. It is essential that you read the instructions and safety regulations before you attempt to assemble or use this unit.



DANGER : Indicates an imminently hazardous situation which, if not avoided, will result in death or serious injury.



WARNING : Indicates a potentially hazardous situation which, if not avoided, could result in death or serious injury.



CAUTION: Indicates a potentially hazardous situation which, if not avoided, may result in minor or moderate injury.

IMPORTANT : Indicates that equipment or property damage could result if instructions are not followed.

NOTE : Gives helpful information.

CONTENTS

▲ SAFE OPERATION 1

SERVICING OF TRACTOR.....7

SPECIFICATIONS.....8

SPECIFICATION TABLE8

TRAVELING SPEEDS9

IMPLEMENT LIMITATIONS 10

Operation Section

INSTRUMENT PANEL AND CONTROLS .. 12

PRE-OPERATION CHECK 14

DAILY CHECK 14

OPERATING THE ENGINE 15

STARTING THE ENGINE 15

COLD WEATHER STARTING..... 17

STOPPING THE ENGINE 18

WARMING UP 18

JUMP STARTING 19

OPERATING THE TRACTOR20

OPERATING NEW TRACTOR 20

STARTING20

STOPPING26

CHECK DURING DRIVING26

PARKING27

OPERATING TECHNIQUES27

REVERSING THE SEAT29

PTO30

PTO OPERATION30

THREE-POINT HITCH & DRAWBAR31

3-POINT HITCH.....32

FIXED HITCH(Option)33

HYDRAULIC UNIT34

3-POINT HITCH CONTROL SYSTEM34

TIRES, WHEELS AND BALLAST35

TIRES35

BALLAST36

Maintenance Section

MAINTENANCE37

SERVICE INTERVALS37

LUBRICANTS38

PERIODIC SERVICE39

HOW TO OPEN THE HOOD39

DAILY CHECK39

EVERY 50 HOURS 42

EVERY 100 HOURS 45

EVERY 200 HOURS 48

EVERY 400 HOURS 51

EVERY 800 HOURS 52

EVERY 1 YEAR 52

EVERY 2 YEARS 52

SERVICE AS REQUIRED 54

STORAGE56

TRACTOR STORAGE 56

REMOVING THE TRACTOR
FROM STORAGE 56

TROUBLESHOOTING57

ENGINE TROUBLESHOOTING.....57

OPTIONS58



SAFE OPERATION

Careful operation is your best insurance against an accident.

Read and understand this section carefully before operating the tractor.

All operators, no matter how much experience they may have had, should read this and other related manuals before operating the tractor or any implement attached to it. It is the owner's obligation to instruct all operators in safe operation.

1. BEFORE OPERATING THE TRACTOR

- (1) Know your equipment and its limitations. Read this entire manual before attempting to start and operate the tractor.
- (2) Pay special attention to the danger, warning and caution labels on the tractor itself.
- (3) KUBOTA recommends the use of a Roll Over Protective Structures (ROPS) and seat belt in almost all applications. This combination will reduce the risk of serious injury or death, should the tractor be upset.

If the ROPS is loosened or removed for any reason, make sure that all parts are reinstalled correctly before operating the tractor.

Never modify or repair a ROPS because welding, bending, drilling, grinding, or cutting any portion may weaken the structure.

A damaged ROPS structure must be replaced, not repaired or revised. If any structural member of the ROPS is damaged, replace the entire structure at your local KUBOTA dealer.

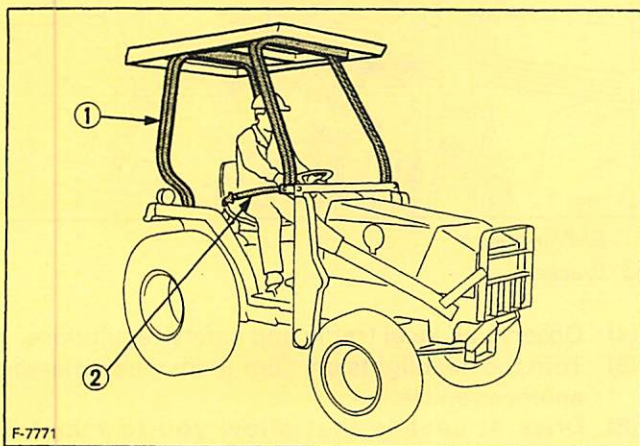

① ROPS

② Seat belt

- (4) Always use the seat belt if the tractor has a ROPS. Do not use it if there is no ROPS. Check the seat belt regularly and replace if frayed or damaged.

- (5) Do not operate tractor or any implement attached to it while under the influence of alcohol, medication, or other substances or while fatigued.
- (6) Carefully check the vicinity before operating tractor or any implement attached to it. Check for overhead clearance which may interfere with a ROPS. Do not allow any bystanders around or near tractor during operation.
- (7) Before allowing other people to use your tractor, explain how to operate and have them read this manual before operation.
- (8) Never wear loose, torn, or bulky clothing around tractor. It may catch on moving parts or controls, leading to the risk of accident. Use additional safety items, e.g. hard hat, safety boots or shoes, eye and hearing protection, gloves, etc., as appropriate or required.
- (9) Do not allow passengers to ride on any part of the tractor at anytime. The operator must remain in the tractor seat throughout operation.
- (10) Check brakes, clutch, and other mechanical parts for improper adjustment and wear. Replace worn or damaged parts promptly. Check the tightness of all nuts and bolts regularly. (For further details, see Maintenance section.)
- (11) Keep your tractor clean. Dirt, grease, and trash accumulations contribute to fires and lead to personal injury.
- (12) Use only implements meeting the specifications listed under IMPLEMENT LIMITATIONS in this manual and use only implements approved by KUBOTA.
- (13) Use proper weights to front or rear of tractor to reduce the risk of upsets. When using the front loader, put the implement or ballast on 3-point hitch to improve stability. Follow the safe operating procedures specified in the attached manual to the equipment.
- (14) Do not modify the tractor if special applications may be unsafe.

2. OPERATING THE TRACTOR

- (1) Never start engine or operate levers from anywhere other than the seat.
- (2) Before, starting the engine, make sure that all levers (including auxiliary control levers) are in their neutral positions, that the parking brake is engaged, and that both the clutch and the Power Take-Off (PTO) are disengaged. Fasten the seat belt if the tractor has a ROPS.
- (3) Do not start engine by shorting across starter terminals or bypassing the safety start switch. Machine may start in gear and move if normal starting circuitry is bypassed.

- (4) Pull only from the drawbar. Never hitch to axle housing or any other point except drawbar; such arrangements only increase the risk of serious personal injury or death due to a tractor upset.

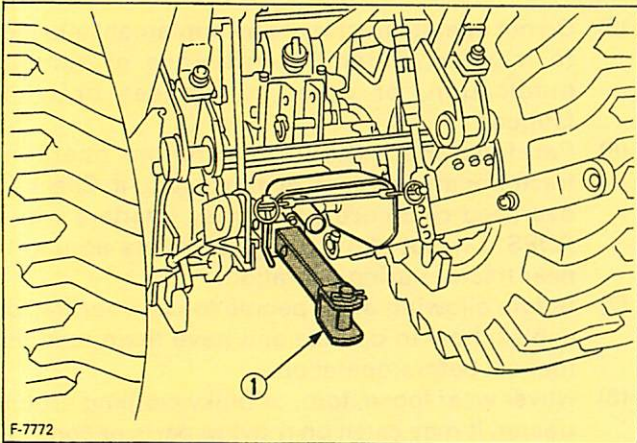

① Drawbar (Fixed hitch, Option)

- (5) Do not operate or idle engine in a non-ventilated area. Carbon monoxide gas is colorless, odorless, and deadly.
- (6) Keep all shields and guards in place. Replace any that are missing or damaged.
- (7) Avoid sudden starts. To avoid upsets, slow down when turning, on uneven terrain, and before stopping.
- (8) The tractor cannot turn with the differential locked and attempting to do so could be dangerous.
- (9) Do not operate near ditches, holes, embankments, or other terrain features which may collapse under the tractor's weight. The risk of tractor upset is even higher when the ground is loose or wet.
- (10) Driving forward out of a ditch or mired condition or up a steep slope risks a tractor to be upset backward. Always back out of these situations. Extra caution is required with four-wheel drive models because their higher traction can give the operator false confidence in the tractor's ability to climb slopes.
- (11) To avoid upsets, always back up steep slopes. Stay off hills and slopes too steep for safe operation.
- (12) Watch where you are going at all times. Watch for and avoid obstacles. Be alert at row ends, near trees, and other obstructions.
- (13) When working in groups, always let the others know what you are going to do before you do it.
- (14) Never "freewheel". Disengaging the clutch or shifting into neutral while descending a slope could lead to a loss of control.
- (15) Never try to get on or off a moving tractor.

3. DRIVING THE TRACTOR ON THE ROAD

- (1) Lock the two brake pedals together to help assure straight-line stops. Uneven braking at road speeds could cause the tractor to tip over.

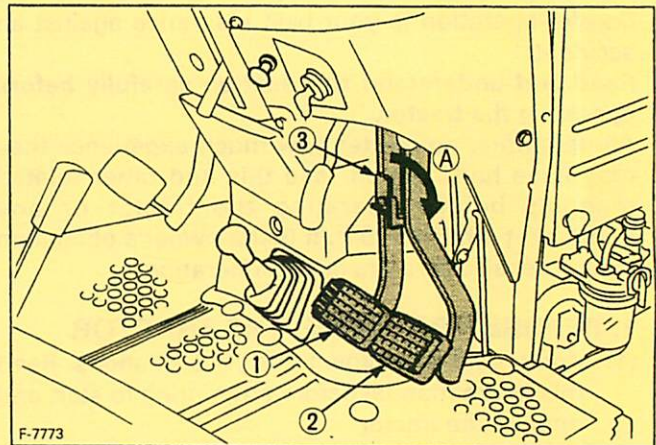

- ① Brake pedal (LH) A Whenever travelling on the road
 ② Brake pedal (RH)
 ③ Brake pedal lock

- (2) Always slow the tractor down before turning. Turning at high speed may tip the tractor over.
- (3) Make sure that the Slow Moving Vehicle (SMV) sign is clean and visible. Use hazard lights as required.

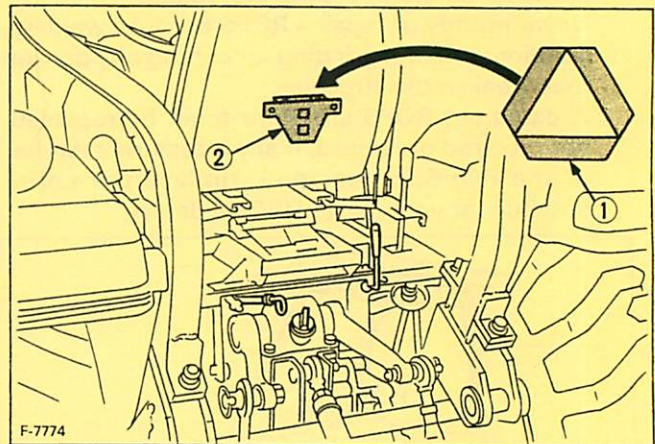

- ① SMV emblem
 ② Bracket

- (4) Observe all local traffic and safety regulations.
- (5) Turn the headlights on. Dim them when meeting another vehicle.
- (6) Drive at speeds that allow you to maintain control at all times.
- (7) Do not apply the differential lock while traveling at road speeds. The tractor may run out of control.
- (8) Avoid sudden motions of the steering wheel as they can lead to a dangerous loss of stability. The risk is especially great when the tractor is traveling at road speeds.

- (9) Do not operate an implement while the tractor is on the road. Lock the 3-point hitch in the raised position.
- (10) When towing other equipment, use a safety chain and place an SMV emblem on it as well.

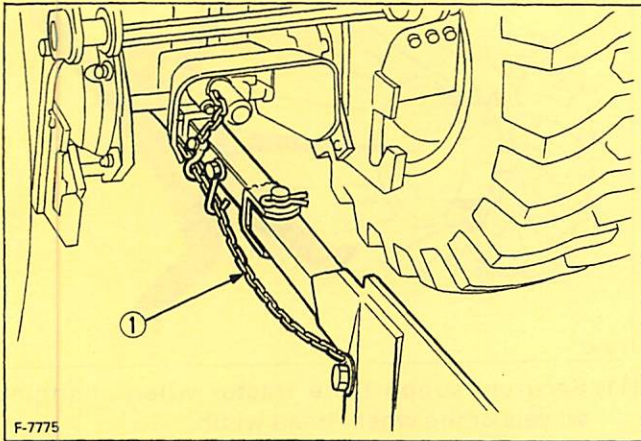

① Safety chain

4. PARKING THE TRACTOR

- (1) Disengage the PTO, lower all implements, place all control levers in their neutral positions, set the parking brake, stop the engine, and remove the key.
- (2) Make sure that the tractor has come to a complete stop before dismounting.

5. OPERATING THE PTO

- (1) Wait until all moving components have completely stopped before getting off the tractor, connecting, disconnecting, adjusting, cleaning, or servicing any PTO driven equipment.
- (2) Keep the PTO shaft cover in place at all times. Replace the PTO shaft cap when the shaft is not in use.

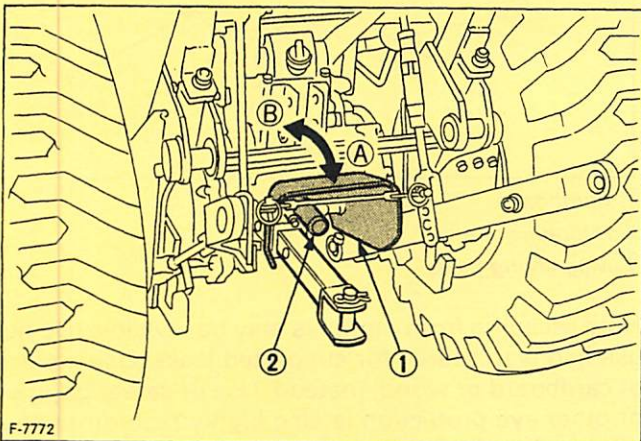

① PTO shaft cover

A "NORMAL POSITION"

② PTO shaft cap

B "RAISED POSITION"

- (3) Before installing or using PTO driven equipment, read the manufacturer's manual and review the safety labels attached to the equipment.

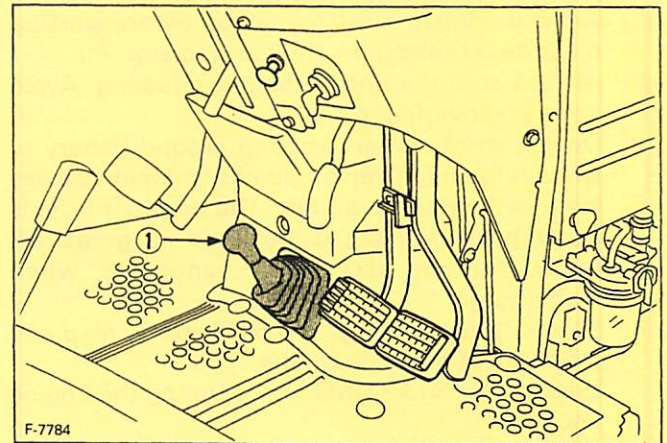

① PTO gear shift lever

- (4) When operating stationary PTO driven equipment, always apply the tractor parking brake and place chocks behind and in front of the rear wheels. Stay clear of all rotating parts.

6. USING 3-POINT HITCH

- (1) Use the 3-point hitch only with equipment designed for 3-point hitch usage.
- (2) When using a 3-point hitch mounted implement, be sure to install the proper counterbalance weight on the front of the tractor.
- (3) When transporting on the road, set the implement lowering control in the "LOCK" position to hold the implement in the raised position.

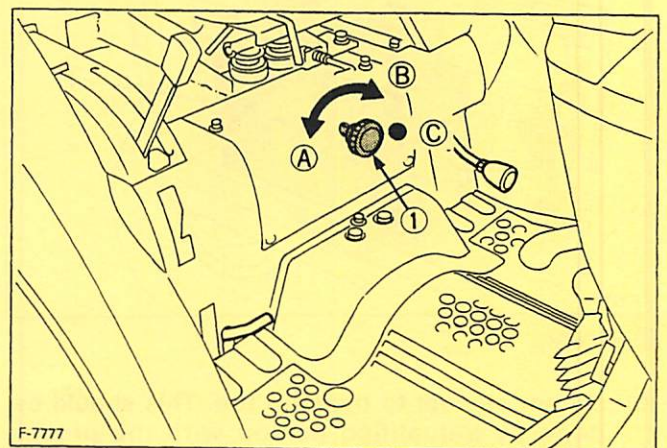

① 3-point hitch lowering speed knob

A "FAST"

B "SLOW"

C "LOCK"

7. SERVICING THE TRACTOR

Before servicing the tractor, park it on a firm level surface, set the parking brake, place the gear shift lever in neutral and stop the engine.

- (1) Allow the tractor time to cool off before working on or near the engine, muffler, radiator, etc.
- (2) Always stop the engine before refueling. Avoid spills and overfilling.
- (3) Do not smoke when working around battery or when refueling. Keep all sparks and flames away from battery and fuel tank. The battery presents an explosive hazard because it gives off hydrogen and oxygen.... especially when recharging.
- (4) Before "jump starting" a dead battery, read and follow all of the instructions. (See "JUMP STARTING" in Operating the Engine Section)
- (5) Keep first aid kit and fire extinguisher handy at all times.
- (6) Do not remove radiator cap while coolant is hot. When cool, slowly rotate cap to the first stop and allow sufficient time for excess pressure to escape before removing the cap completely. If the tractor has a coolant recovery tank, add coolant there instead of to the radiator.
- (7) Disconnect the battery's ground cable before working on or near electric components.
- (8) To avoid sparks from an accidental short circuit, always disconnect the battery's ground cable ⊖ first and connect it last.

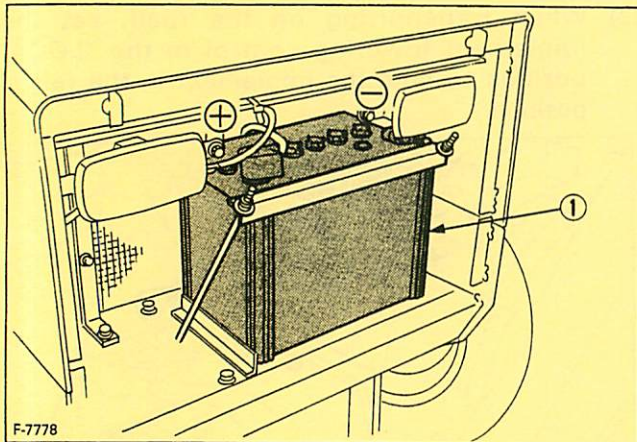

① Battery

- (9) Do not attempt to mount a tire. This should be done by a qualified person with the proper equipment.

- (10) Always maintain the correct tire pressure. Do not inflate tires above the recommended pressure shown in the operator's manual.



- (11) Securely support the tractor when changing wheels or the wheel tread width.
- (12) Make sure that wheel bolts have been tightened to the specified torque.
- (13) Escaping hydraulic fluid under pressure has sufficient force to penetrate skin, causing serious personal injury. Before disconnecting hydraulic lines, be sure to release all residual pressure. Before applying pressure to the hydraulic system, make sure that all connections are tight and that all lines, pipes, and hoses are free of damage.

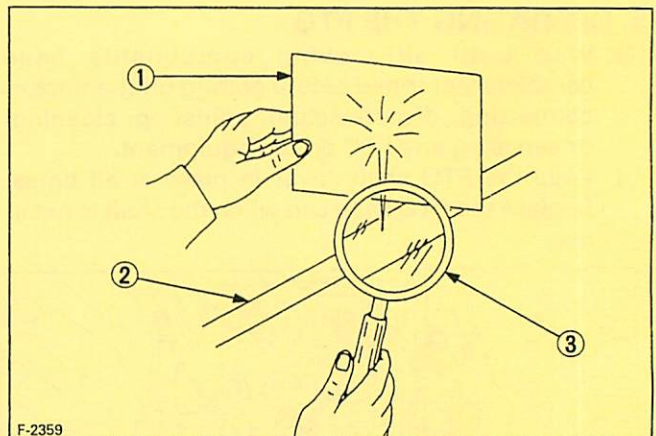

- ① Cardboard
- ② Hydraulic line
- ③ Magnifying glass

Fluid escaping from pinholes may be invisible. Do not use hands to search for suspected leaks; Use a piece of cardboard or wood, instead. Use of safety goggles or other eye protection is also highly recommended. If injured by escaping fluid, see a medical doctor at once. This fluid can produce gangrene or severe allergic reaction.

8. DANGER, WARNING AND CAUTION LABELS

① Part No. TA040-4965-2

	<p>⚠ DANGER</p> <p style="text-align: right;">TA040-49652 ©</p>
	<p>TO AVOID POSSIBLE INJURY OR DEATH FROM A MACHINE RUNAWAY.</p> <ol style="list-style-type: none"> Do not start engine by shorting across starter terminals or bypassing the safety start switch. Machine may start in gear and move if normal starting circuitry is bypassed. Start engine only from operator's seat with transmission and PTO OFF. Never start engine while standing on the ground.

⑥ Part No. 32751-4921-2

<p>⚠ WARNING</p>
<p>TO AVOID SERIOUS PERSONAL INJURY OR DEATH:</p> <ol style="list-style-type: none"> Keep tractor seat in forward position except when operating backhoe. Using seat in reversed position while operating attachments other than backhoe may result in entanglement with PTO shaft or 3-point hitch. <p style="text-align: right;">32751-49212 ©</p>

② Part No. TA040-4932-2

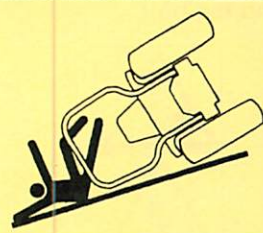
<p>⚠ WARNING</p>	<p>TO AVOID PERSONAL INJURY OR DEATH FROM ROLL-OVER:</p> <ol style="list-style-type: none"> Kubota recommends the use of a Roll-Over Protective Structures (ROPS) and seat belt in almost all applications. Remove the ROPS only when it substantially interferes with operation or itself presents a safety risk. (Examples include work in orchards and vineyards.) ALWAYS REINSTALL IT BEFORE USING THE TRACTOR IN OTHER APPLICATIONS. Never use just the seat belt or just the ROPS. They must be used together. For further details, consult your Operator's Manual or your local dealer. <p style="text-align: right;">TA040-49322 ©</p>
	

⑦ Part No. 35080-6528-2

<p>⚠ CAUTION</p>
<p>Pull the engine stop knob back and hold it until the engine stops in case of emergency.</p> <p style="text-align: right;">35080-65282 ©</p>

③ Part No. TA040-4933-2

<p>⚠ WARNING</p>	<p>BEFORE DISMOUNTING TRACTOR:</p> <ol style="list-style-type: none"> PARK ON LEVEL GROUND WHENEVER POSSIBLE. If parking on a gradient, position tractor at right angles to the slope. ALWAYS SET PARKING BRAKE. Leaving transmission in gear with the engine stopped will not prevent tractor from rolling. LOWER ALL IMPLEMENTS TO THE GROUND. Failure to comply to this warning may allow the wheels to slip, and could cause injury or death. LOCK SHUTTLE SHIFT LEVER IN NEUTRAL POSITION AND STOP THE ENGINE. <p style="text-align: right;">TA040-49332 ©</p>
	

⑧ Part No. TA040-4935-1

<p>⚠ WARNING</p>
<p>TO AVOID PERSONAL INJURY:</p> <ol style="list-style-type: none"> Attach pulled or towed loads to the drawbar only. Use the 3-point hitch only with equipment designed for 3-point hitch usage. <p style="text-align: right;">TA040-49351 ©</p>

④ Part No. TA040-4959-2

<p>⚠ WARNING</p> <p style="text-align: right;">TA040-49592 ©</p>	<p>TO AVOID PERSONAL INJURY.</p> <ol style="list-style-type: none"> Keep PTO shield in place at all times. Before using PTO, set drawbar at 14in. (356mm) from drawbar pin hole to the end of PTO shaft. Do not operate the PTO at speeds faster than the speed recommended by the implement manufacturer.
	

⑤ Part No. TA040-4956-1

Diesel fuel only No fire

	
<p style="font-size: small;">TA040-49561</p>	

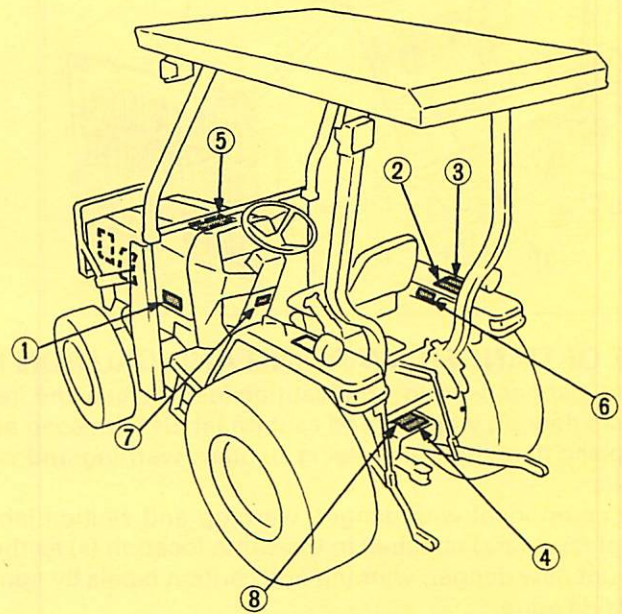

⑨ Part No. 35260-3491-3

CAUTION 35260-34913③

TO AVOID PERSONAL INJURY:

1. Read and understand the operator's manual before operation.
2. Before starting the engine, make sure that everyone is at a safe distance from the tractor and that the PTO is OFF.
3. Do not allow passengers on the tractor at any time.
4. Before allowing other people to use the tractor, have them read the operator's manual.
5. Check the tightness of all nuts and bolts regularly.
6. Keep all shields in place and stay away from all moving parts.
7. Lock the two brake pedals together before driving on the road.
8. Slow down for turns, or rough roads, or when applying individual brakes.
9. On public roads use SMV emblem and hazard lights, if required by local traffic and safety regulations.
10. Pull only from the drawbar.
11. Before dismounting, lower the implement, set the parking brake, stop the engine and remove the key.

⑫ Part No. TA040-4958-1
Do not touch hot surface like muffler, etc.



⑬ Part No. 32751-4958-1
Stay clear of engine fan and fan belt.



⑩ Part No. TA040-3015-1

DANGER EXPLOSIVE GASES Cigarettes, flames or sparks could cause battery to explode. Always shield eyes and face from battery. Do not charge or use booster cables or adjust post connections without proper instruction and training.
KEEP VENT CAPS TIGHT AND LEVEL

POISON CAUSES SEVERE BURNS Contains sulfuric acid. Avoid contact with skin, eyes or clothing. In event of accident flush with water and call a physician immediately.
KEEP OUT OF REACH OF CHILDREN

⑪ Part No. 32751-4957-1
Stay clear of engine fan and fan belt.

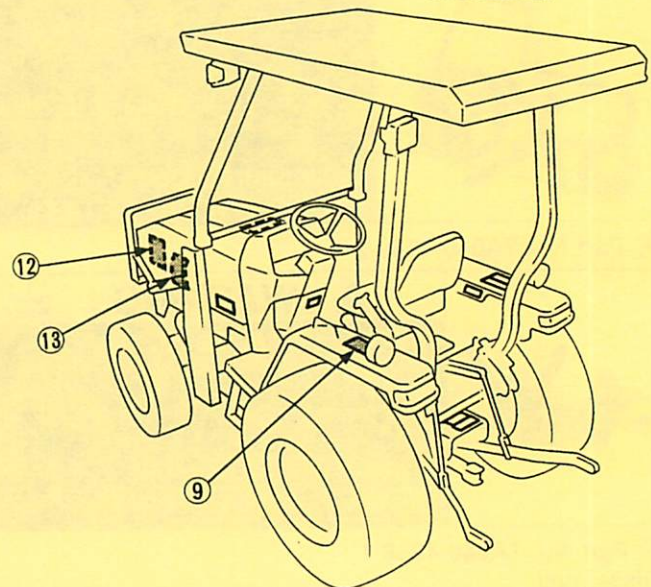
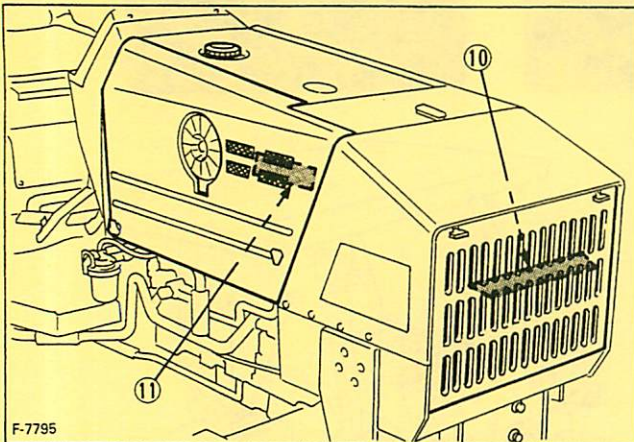

CARE OF DANGER, WARNING AND CAUTION LABELS

- (1) Keep danger, warning and caution labels clean and free from obstructing material.
- (2) Clean danger, warning and caution labels with soap and water, dry with a soft cloth.
- (3) Replace damaged or missing danger, warning and caution labels with new labels from your local KUBOTA dealer.
- (4) If a component with danger, warning and caution label (s) affixed is replaced with new part, make sure new label (s) is (are) attached in the same location (s) as the replaced component.
- (5) Mount new danger, warning and caution labels by applying on a clean dry surface and pressing any bubbles to outside edge.

SERVICING OF TRACTOR

Your dealer is interested in your new tractor and has the desire to help you get the most value from it. After reading this manual thoroughly, you will find that you can do some of the regular maintenance yourself. However, when in need of parts or major service, be sure to see your KUBOTA dealer.

For service, contact the KUBOTA Dealership from which you purchased your tractor or your local KUBOTA dealer.

When in need of parts, be prepared to give your dealer both the tractor and engine serial numbers. Locate the serial numbers now and record them in the space provided.

	Type	Serial No.
--	------	------------

Tractor	_____	_____
---------	-------	-------

Engine	_____	_____
--------	-------	-------

Date of Purchase	_____	_____
------------------	-------	-------

Name of Dealer	_____	
(To be filled in by purchaser)		

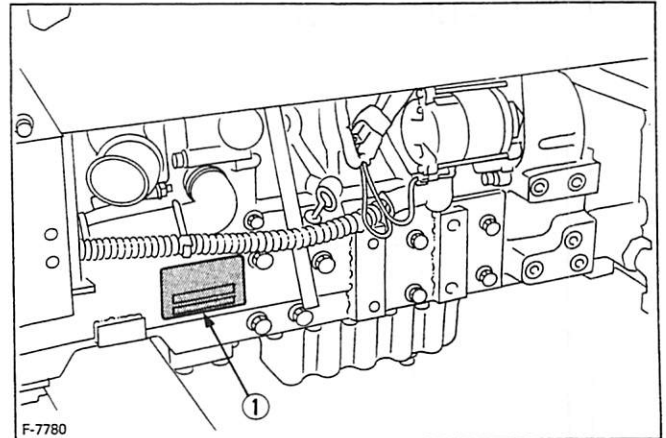

① Tractor identification plate

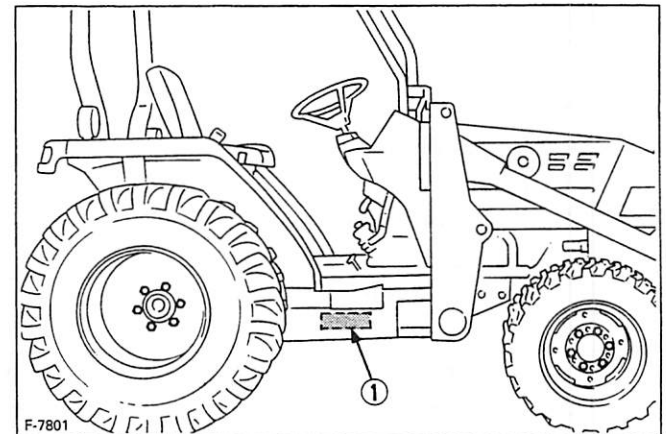

① Tractor serial number

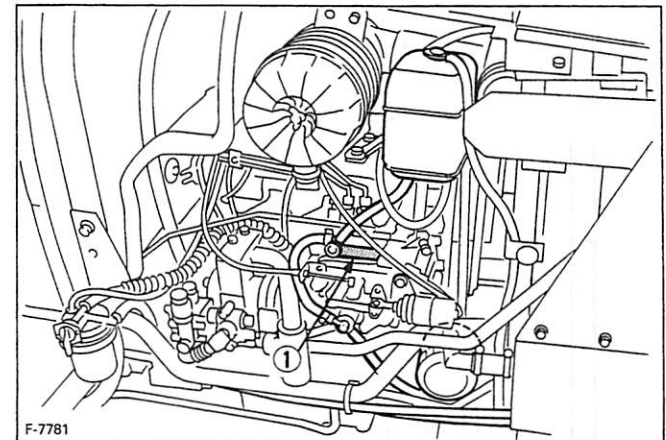

① Engine serial number

SPECIFICATIONS

SPECIFICATION TABLE

Model		L35	
Engine gross power		26.2 kW (35.1 HP) *	
PTO power		19.4 kW (26 HP) *	
Engine	Model	D1703	
	Type	Vertical, water-cooled, 4-cycle diesel	
	No. of cylinders	3	
	Bore and stroke	87 mm X 92.4 mm (3.4 in. X 3.6 in.)	
	Total displacement	1647 cm ³ (100.5 cu.in.)	
	Rated revolution	45 r/s (2700 rpm)	
	Fuel	Diesel fuel No. 2-D	
	Starter	Electric starter with battery, glow plug, 12V, 1.0kW	
	Lubrication	Forced lubrication by trochoid pump	
	Cooling	Water with pressurized radiator	
Battery	12V		
Capacities	Fuel tank	35 ℓ (9.2 U.S.gals.)	
	Engine crankcase (with filter)	4.8 ℓ (5.1 U.S.qts.)	
	Engine coolant	7.0 ℓ (7.4 U.S.qts.)	
	Transmission case	39 ℓ (41.2 U.S.qts.)	
	Front axle case	5.5 ℓ (5.8 U.S.qts.)	
Tires	Front	27X10.5-15 (NHS, Trac Loader)	
	Rear	15-19.5 (NHS, Trac Loader)	
Dimensions	Overall length (without 3P)	mm (in.)	2720 (107.1)
	Overall width	mm (in.)	1590 (62.3)
	Overall height with ROPS & FOPS	mm (in.)	2400 (94.5)
	Wheel base	mm (in.)	1700 (66.9)
	Min. ground clearance	mm (in.)	325 (12.8)
	Tread	Front	mm (in.)
Rear		mm (in.)	1200 (47.2)
Weight	kg (lbs.)	1450 (3197)	
PTO shaft		Transmission case rear	
Rear PTO		SAE 1-3/8 1 speed (9 r/s at 37.0 engine r/s) (540 rpm at 2219 engine rpm)	
Clutch		Dry single plate	
Steering		Hydrostatic power steering	
Transmission		Glide shift transmission; 8 forward and 8 reverse	
Min. turning radius m (feet)		2.47 (8.1) **	
Brake		Right and left independent with interlocking device	
Differential		Bevel gear	

NOTE: * Manufacturer's estimate
** with brake

The company reserves the right to change the specifications without notice.

TRAVELING SPEEDS

(At rated engine rpm)

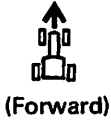
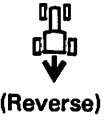
Model	L35		
Tire size (Rear)	15—19.5		
Shuttle shift lever	Main gear shift lever	km/h	mph
 (Forward)	1	1.4	0.9
	2	2.0	1.3
	3	3.3	2.0
	4	4.9	3.0
	5	6.9	4.3
	6	9.7	6.0
	7	15.8	9.8
	8	23.3	14.5
 (Reverse)	1	1.3	0.8
	2	1.9	1.1
	3	3.0	1.9
	4	4.4	2.8
	5	6.3	3.9
	6	8.9	5.5
	7	14.5	9.0
	8	21.4	13.3

The company reserves the right to change the specifications without notice.

IMPLEMENT LIMITATIONS

The KUBOTA Tractor has been thoroughly tested for proper performance with implements sold or approved by KUBOTA. Use with implements which exceed the maximum specifications listed below, or which are otherwise unfit for use with the KUBOTA Tractor may result in malfunctions or failures of the tractor, damage to other property and injury to the operator or others. [Any malfunctions or failures of the tractor resulting from use with improper implements are not covered by the warranty.]

Tread (max. width)		Operating condition	Lower link end max. loading weight W_0	Actual figures	
Front	Rear			Implement weight W_1	Trailer loading weight W_2
1165 mm (45.9 in.)	1200 mm (47.2 in.)	General control operation (Flat ground and slope condition)	Below 1200 kg (2645 lbs.)	As in the following list	Below 1500 kg (3300 lbs.)

Lower link end max. loading weight ... The max. allowable load which can be put on the lower link end: W_0
 Implement weight The implement's weight which can be put on the lower link: W_1
 Trailer loading weight The max. loading weight for trailer (without trailer's weight): W_2

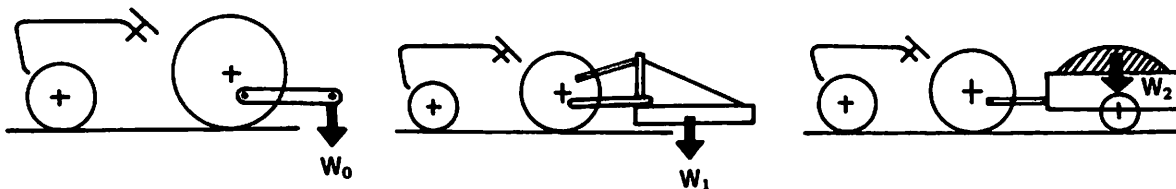

NOTE:

- Implement size may vary depending on soil operating conditions.

No.	Implement	Remarks	L35	
1	Trailer	Max. Load Capacity kg (lbs.)	1500 (3300)	
		Max. Drawbar Load kg (lbs.)	500 (1100)	
2	Mower	Rotary Cutter	Max. Cutting Width mm (in.)	1829 (72)
			Max. Weight kg (lbs.)	350 (770)
		Flail Mower	Max. Cutting Width mm (in.)	1524 (60)
			Max. Weight kg (lbs.)	400 (880)
		Sickle Bar	Max. Cutting Width mm (in.)	2133 (84)
			Max. Weight kg (lbs.)	500 (1100)
3	Sprayer	Max. Tank capacity ℓ (gals.)	Rear mounted 400 (106)	
			Pull type 1000 (264)	
4	Rotary Tiller	Max. Tilling Width mm (in.)	1520 (60)	
5	Backhoe *	Max. Digging Depth mm (ft)	2780 (9.2)	
		Max. Weight kg (lbs.)	750 (1655)	
6	Disc-harrow (Pull type)	Max. Harrowing Width mm (in.)	1829 (72)	
		Max. Weight kg (lbs.)	350 (770)	
7	Chisel Plow	Max. Cutting Width mm (in.)	1829 (72)	
		Max. Weight kg (lbs.)	350 (770)	
8	Broad Caster	Max. Tank Capacity ℓ (gals.)	250 (66)	
		Max. Weight kg (lbs.)	100 (220)	
9	Manure Spreader	Max. Capacity kg (lbs.)	2000 (4400)	
10	Cultivator	Max. Width mm (in.)	2134 (84)	
		Number of Rows	2	
		Max. Weight kg (lbs.)	350 (770)	
11	Rear Blade	Max. Cutting Width mm (in.)	1829 (72)	
		Max. Oil Pressure kgf/cm ² (psi.)	175 (2490)	
12	Front-end Loader **	Max. Lifting Capacity kg (lbs.)	750	
		Max. Oil Pressure kgf/cm ² (psi.)	175 (2490)	
13	Box Blade	Max. Cutting Width mm (in.)	1829 (72)	
		Max. Weight kg (lbs.)	400 (880)	

* KUBOTA provides BT900 Backhoe for L35.

No other Backhoe installed by 3-point hitch is permitted for L35.

** KUBOTA provide TL720 Front-end Loader for L35

NOTE:

- Implement size may vary depending on soil operating conditions.

INSTRUMENT PANEL AND CONTROLS

■ Instrument Panel, Switches and Hand Controls

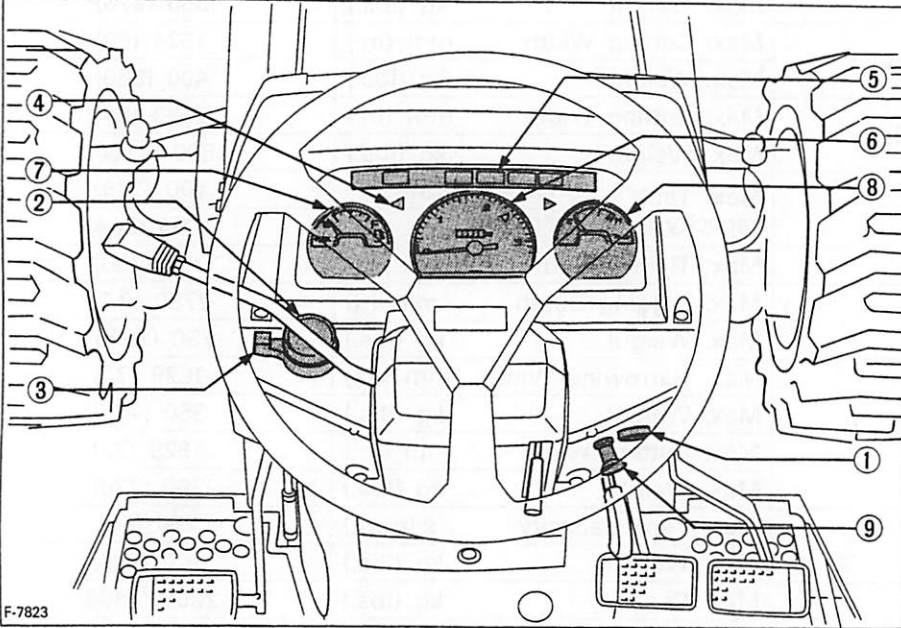

ILLUSTRATED CONTENTS

① Key switch	16
② Head light switch	22
③ Hazard light switch	22
④ Hazard light indicator	22
⑤ Easy Checker™	17,27
⑥ Hourmeter/Tachometer	28
⑦ Fuel gauge	27
⑧ Coolant temperature gauge	28
⑨ Engine stop knob	18

Foot and Hand Controls

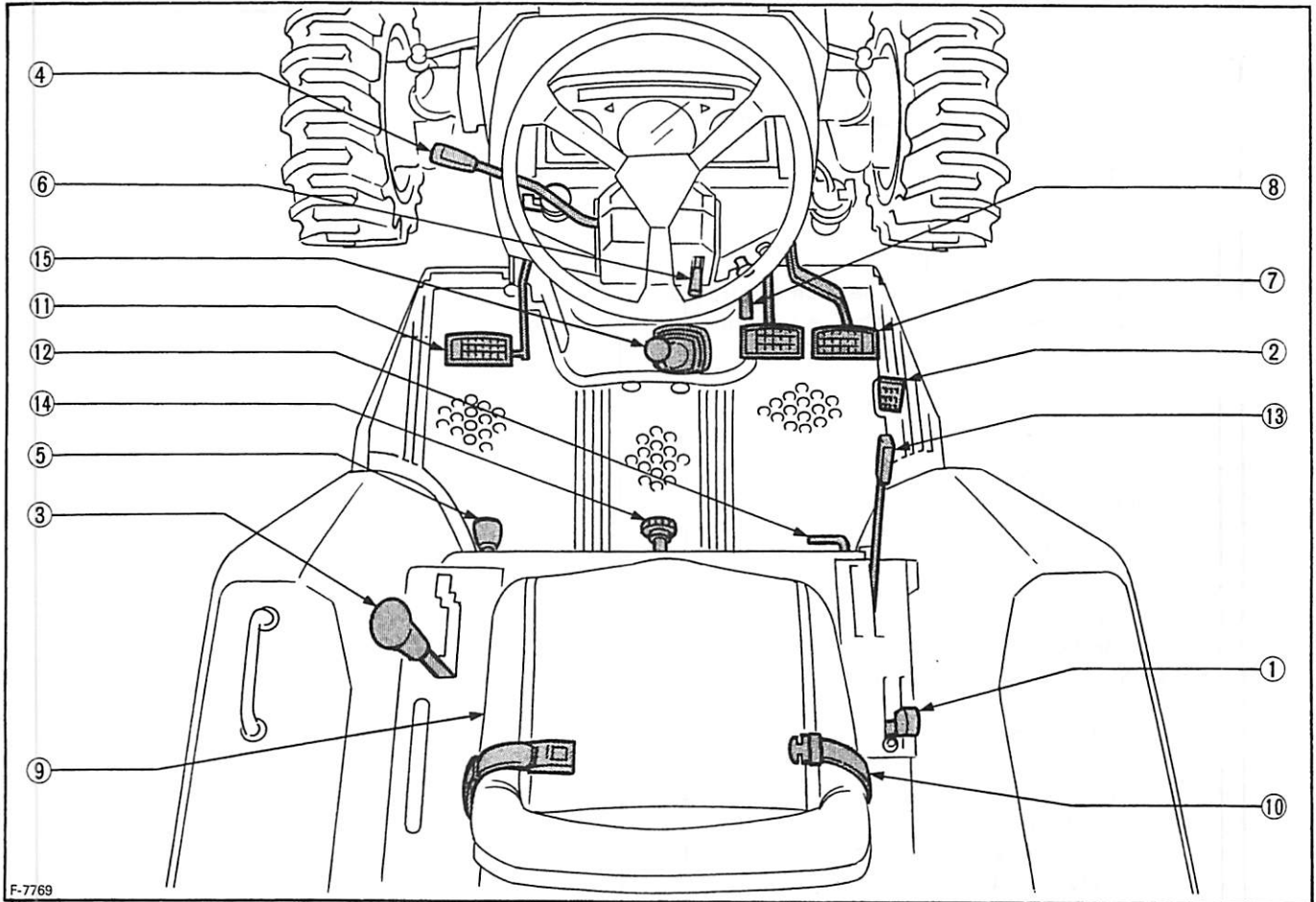

F-7769

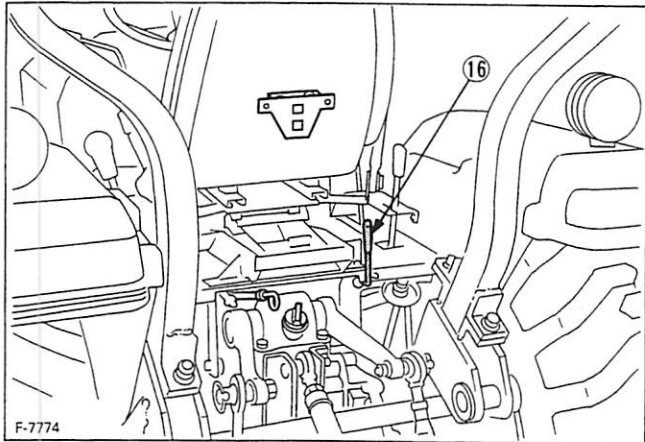

F-7774

ILLUSTRATED CONTENTS

① Hand throttle lever	16,26
② Foot throttle	16,26
③ Main gear shift lever	16,24,25
④ Shuttle shift lever	16,24
⑤ Front wheel drive lever	26
⑥ Steering wheel tilt lever	22
⑦ Brake pedal	22
⑧ Parking brake lever	15,26
⑨ Operator's seat	21
⑩ Seat belt	21
⑪ Clutch pedal	23
⑫ Differential lock pedal	28,29
⑬ Position control lever	16,34
⑭ 3-Point hitch lowering speed knob	34
⑮ PTO gear shift lever	16,30
⑯ Directional valve lever	34

PRE-OPERATION CHECK

DAILY CHECK

To prevent trouble from occurring, it is important to know the conditions of the tractor well. Check it before starting.



CAUTION

To avoid personal injury:

- Be sure to check and service the tractor on a level surface with the engine shut off and the parking brake "ON".

Check item

- Walk around inspection
- Check engine oil level
- Check transmission oil level
- Check coolant level
- Clean grill and radiator screen
- Check air cleaner evacuator valve
(When used in a dusty place)
- Check brake and clutch pedal
- Check indicators, gauges and meter
- Check lights
- Check seat belt, ROPS & FOPS
- Refuel
(See "DAILY CHECK" in Periodic Service Section)
- Care of danger, warning and caution labels
(See "DANGER, WARNING AND CAUTION LABELS" in safe operation section.)

OPERATING THE ENGINE



CAUTION

To avoid personal injury:

- Read "Safe Operation" in the front of this manual.
- Read the danger, warning and caution labels located on the tractor.
- To avoid the danger of exhaust fume poisoning, do not operate the engine in a closed building without proper ventilation.
- Never start engine while standing on ground.
Start engine only from operator's seat.

IMPORTANT:

- Do not use starting fluid or ether.
- When starting the engine after long storage (of more than three months), first pull the engine stop knob and then activate the starter for about ten seconds to allow oil to reach every engine part.
- To protect the battery and the starter, make sure that the starter is not continuously turned for more than 30 seconds.

STARTING THE ENGINE

1. Set the parking brake

- (1) To set the parking brake;
 - 1) Interlock the brake pedals.
 - 2) Depress the brake pedals.
 - 3) Latch the brake pedals with the parking brake lever.
- (2) To release the parking brake, depress the brake pedals again.

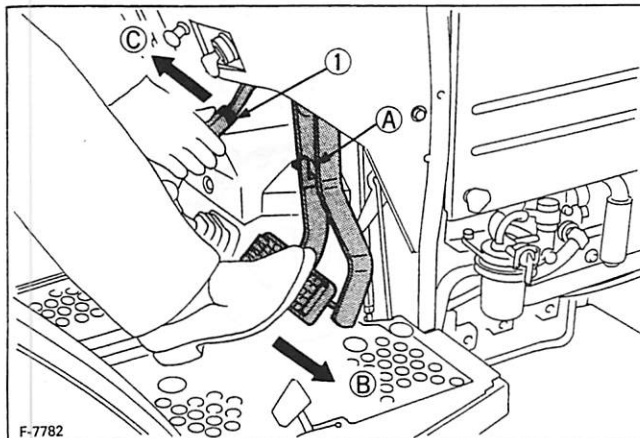

- ① Parking brake lever
- Ⓐ Interlock the brake pedals
- Ⓑ "DEPRESS"
- Ⓒ "PULL"

2. Make sure the fuel cock is in the "OPEN" position.

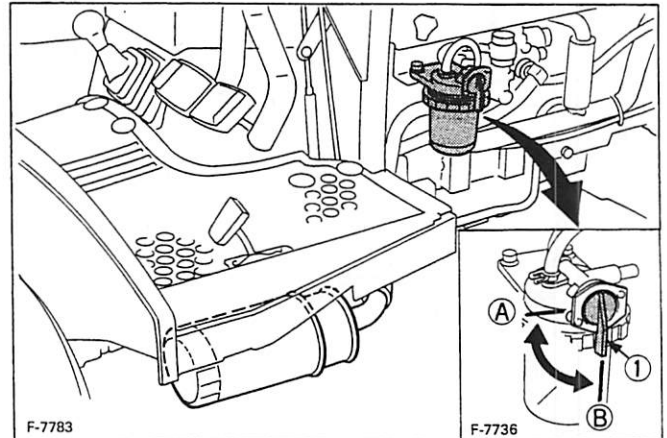

- ① Fuel cock
- Ⓐ "CLOSE"
- Ⓑ "OPEN"

3. Make sure the engine stop knob is pushed in.

Push in the engine stop knob if it is pulled out, or the engine will not start.

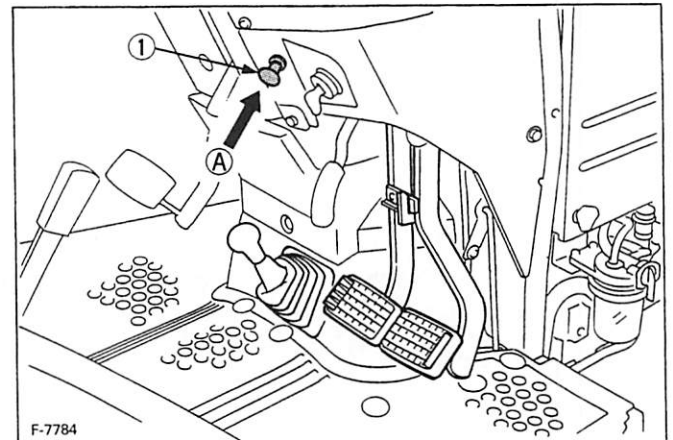

- ① Engine stop knob
- Ⓐ "PUSH"

4. Place the shift levers in "NEUTRAL" position.

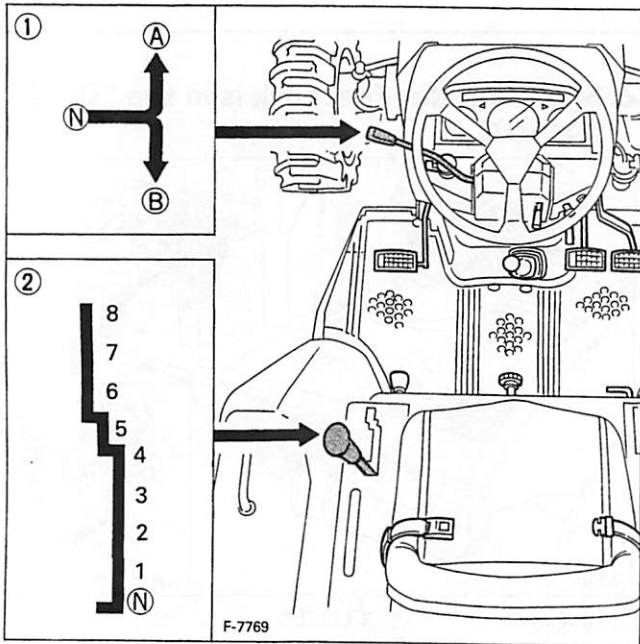

- ① Shuttle shift lever A "FORWARD"
- B "REVERSE"
- ② Main gear shift lever N "NEUTRAL POSITION"

5. Place the PTO gear shift lever in "DISENGAGE" position.

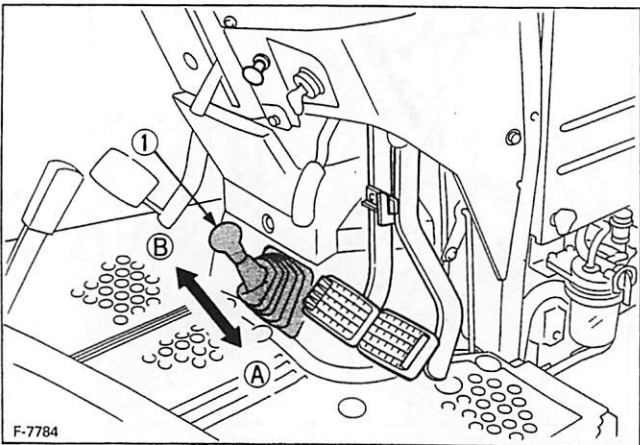

- ① PTO gear shift lever A "ENGAGE"
- B "DISENGAGE"

6. Place the hydraulic control lever in "LOWEST" position.

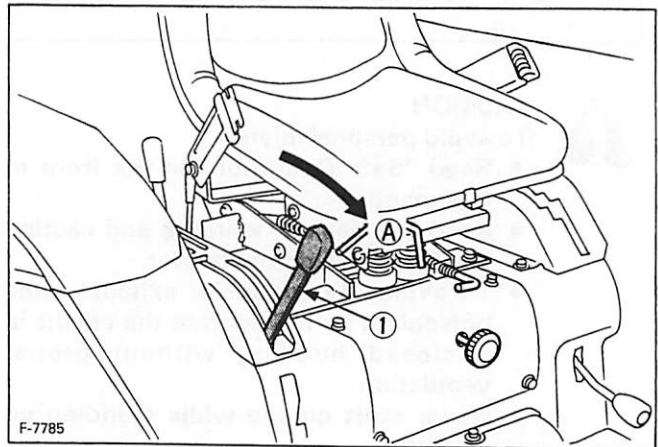

- ① Position control lever A "DOWN"

7. Set the throttle lever to about 1/2 way.

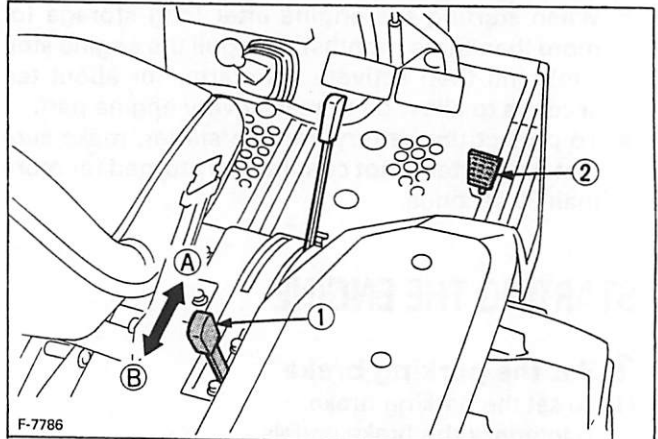

- ① Hand Throttle lever A "INCREASE"
- ② Foot Throttle B "DECREASE"

8. Insert the key into the key switch and turn it "ON".

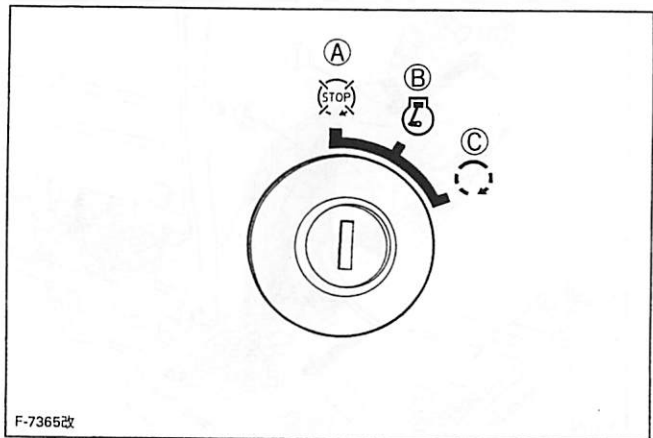

- A "OFF"
- B "ON"
- C "START"

◆ Check Easy Checker™ lamps:

- (1) When the key is turned "ON", ③ ⑤ lamps should come on. If trouble should occur at any location while the engine is running, the warning lamp corresponding to that location comes on.
- (2) Glow plug indicator ⑥ comes "ON" while engine is being preheated and goes off automatically when preheat is completed. Illuminating time of indicator varies according to the temperature of cooling water.
- (3) The parking brake warning lamp ⑦ comes "ON" while parking brake is applied and goes off when released it.

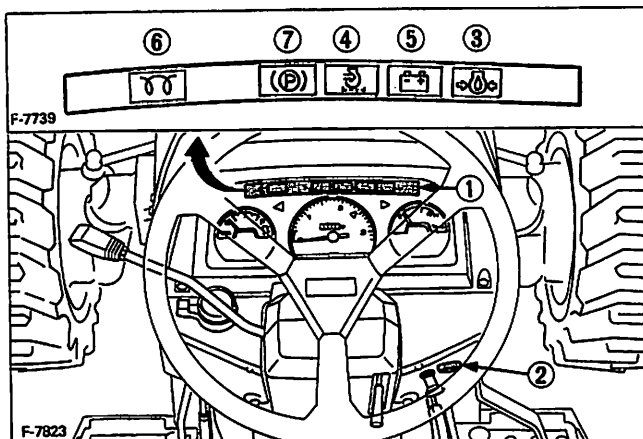

- ① Easy checker™
- ② Key switch
- ③ Engine oil pressure
- ④ Air cleaner
- ⑤ Electrical charge
- ⑥ Glow plug indicator
- ⑦ Parking brake

IMPORTANT:

- Daily checks with the Easy Checker™ only, are not sufficient. Never fail to conduct daily checks carefully by referring to Daily Check. (See "DAILY CHECK" in Periodic Service Section)

9. Fully depress the clutch pedal.

10. Turn the key to "START" position and release when the engine starts.

IMPORTANT:

- Because of the safety device, the engine will not start except when the PTO gear shift lever placed in the "OFF" position and shuttle shift lever placed in the "NEUTRAL" position.

11. Check to see that all the lamps on the Easy Checker™ are "OFF".

If the lamp is still on, immediately stop the engine and determine the cause.

12. Release the clutch pedal.

COLD WEATHER STARTING

If the ambient temperature is below -5°C (23°F) and the engine is very cold, start it in the following manner:

Take steps (1) through (9) above.

10. Turn the key to "ON" (glow plug) and keep it there until glow plug indicator goes off.

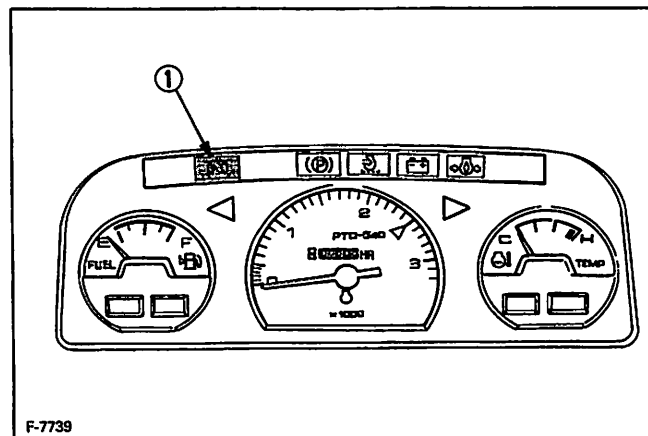

① Glow plug indicator

11. Turn the key to the start position and the engine should start.

(If the engine fails to start after 10 seconds, turn off the key for 30 seconds. Then repeat steps (10) and (11). To protect the battery and the starter, make sure that the starter is not continuously turned for more than 30 seconds.)

■ **Block Heater (Option)**

A block heater is available as an option from your dealer. It will assist you in starting your tractor when the ambient temperature is below -20°C (-4°F).

STOPPING THE ENGINE

1. After slowing the engine to idle, turn the key to "OFF".
2. Remove the key.

■ Engine Stop Knob



CAUTION

To avoid personal injury:

- Pull the engine stop knob back and hold it until the engine stops in case of emergency.

The engine stops when the key is turned OFF.

If the engine does not stop, pull the engine stop knob back and hold it until the engine stops.

After the engine has stopped, be sure to push the engine stop knob back in, or the engine will not start next time.

NOTE:

- If key does not stop the engine, consult your local KUBOTA dealer.

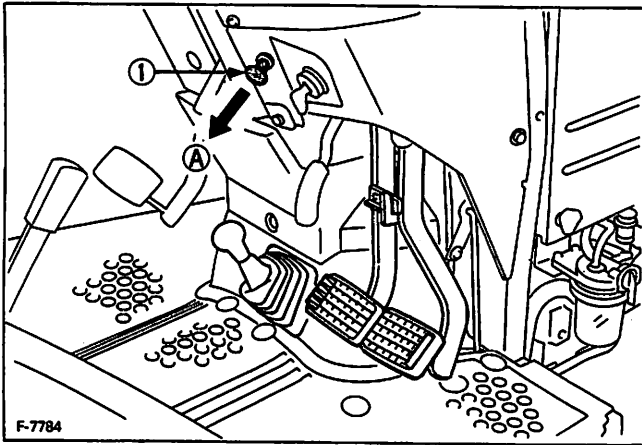

① Engine stop knob

Ⓐ Pull to "STOP"

WARMING UP



CAUTION

To avoid personal injury:

- Be sure to set the parking brake during warm-up.

For five minutes after engine start-up, allow engine to warm up without applying any load, this is to allow oil to reach every engine part. If load should be applied to the engine without this warm-up period, trouble such as seizure, breakage or premature wear may develop.

■ Warm-up and Transmission Oil in the Low Temperature Range

A tractor with GST utilizes a hydraulic clutch. Hydraulic oil serves as transmission oil, and power steering. In cold weather, the oil may be cold with increased viscosity. This can cause delayed oil circulation or abnormally low hydraulic pressure for some time after engine start-up. This in turn can result in trouble in the hydraulic system or damage to the power steering or hydraulic clutch.

To prevent the above, observe the following instructions:

Warm up the engine at about 50% of rated rpm according to the table below:

Ambient temperature	Warm-up time requirement
Above 0°C (32°F)	At least 10 minutes
0 to -10°C (32 to 14°F)	10 to 20 minutes
-10 to -20°C (14 to -4°F)	20 to 30 minutes
Below -20°C (-4°F)	More than 30 minutes

IMPORTANT:

- Do not operate the tractor under full load condition until it is sufficiently warmed up.

JUMP STARTING



CAUTION

To avoid personal injury:

- Battery gases can explode. Keep cigarettes, sparks, and flames away from battery.
- If tractor battery is frozen, do not jump start engine.
- Do not connect other end of negative \ominus jumper cable to negative \ominus terminal of tractor battery.

When jump starting engine, follow the instructions below to safely start the engine.

- (1) Bring helper vehicle with a battery of the same voltage as disabled tractor within easy cable reach. "THE VEHICLES MUST NOT TOUCH".
- (2) Engage the parking brakes of both vehicles and put the shift levers in neutral. Shut the engine off.
- (3) Put on safety goggles and rubber gloves.
- (4) Remove the vent caps from both batteries. (if equipped)
- (5) Cover vent holes with damp rags. Do not allow the rag to touch the battery terminals.
- (6) Attach the red clamp to the positive (red, \oplus or pos.) terminal of the dead battery and clamp the other end of the same cable to the positive (red, \oplus or pos.) terminal of the helper battery.
- (7) Clamp the other cable to the negative (black, \ominus or neg.) terminal of the helper battery.
- (8) Clamp the other end to the engine block or frame of the disabled tractor as far from the dead battery as possible.
- (9) Start the helper vehicle and let its engine run for a few moments. Start the disabled tractor.
- (10) Disconnect the jumper cables in the exact reverse order of attachment. (Steps 8, 7 and 6).
- (11) Remove and discard the damp rags. Reinstall the vent caps.

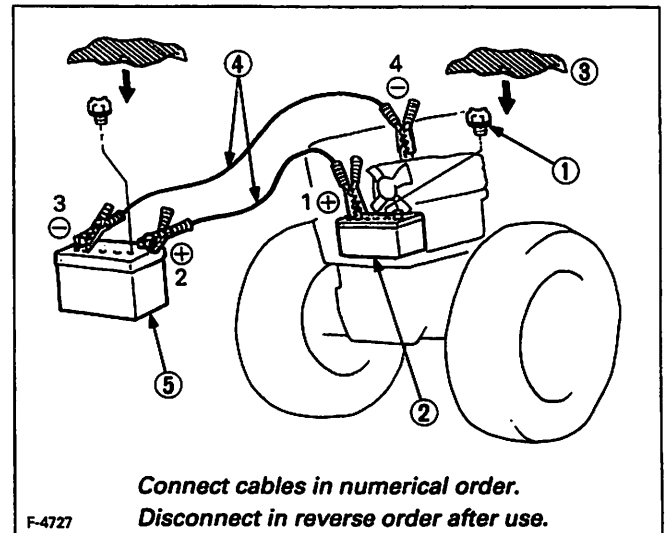

- ① Remove vent caps (if equipped)
- ② Dead battery
- ③ Lay a damp rag over open vents
- ④ Jumper cables
- ⑤ Helper battery

IMPORTANT:

- This machine has a 12volt negative \ominus ground starting system.
- Use only same voltage for jump starting.
- Use of a higher voltage source on tractors electrical system could result in severe damage to tractors electrical system.
Use only matching voltage source when "Jump starting" a low or dead battery condition.

OPERATING THE TRACTOR

OPERATING NEW TRACTOR

How a new tractor is handled and maintained determines the life of the tractor.

A new tractor just off the factory production line has been, of course, tested, but the various parts are not accustomed to each other, so care should be taken to operate the tractor for the first 50 hours at a slower speed and avoid excessive work or operation until the various parts become "broken-in." The manner in which the tractor is handled during the "breaking-in" period greatly affects the life of your tractor. Therefore, to obtain the maximum performance and the longest life of the tractor, it is very important to properly break-in your tractor. In handling a new tractor, the following precautions should be observed.

■ Do not Operate the Tractor at Full Speed for the First 50 Hours.

- Do not start quickly nor apply the brakes suddenly.
- In winter, operate the tractor after fully warming up the engine.
- Do not run the engine at speeds faster than necessary.
- On rough roads, slow down to suitable speeds. Do not operate the tractor at fast speed.

The above precautions are not limited only to new tractors, but to all tractors. But it should be especially observed in the case of new tractors.

■ Changing Lubricating Oil for New Tractors

The lubricating oil is especially important in the case of a new tractor. The various parts are not "broken-in" and are not accustomed to each other; small metal grit may develop during the operation of the tractor; and this may wear out or damage the parts. Therefore, care should be taken to change the lubricating oil a little earlier than would ordinarily be required.

For further details of change interval hours. (See "MAINTENANCE" Section)

STARTING

1. Adjusting the driving position.

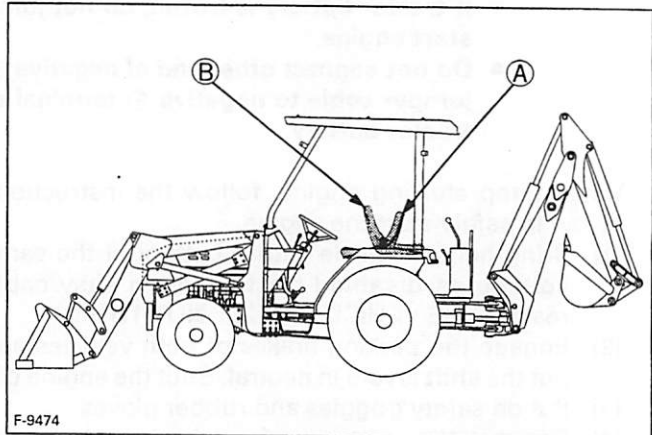

F-9474

- Ⓐ "TRACTOR DRIVING POSITION"
- Ⓑ "BACKHOE POSITION"

■ Operator's Seat



CAUTION

To avoid personal injury:

- Make sure that the seat is completely secured after each adjustment.
- Do not allow any person other than the driver to ride on the tractor.

◆ Travel adjustment

Pull up the travel adjust lever and slide the seat backward or forward, as required. The seat will lock in position when the lever is released.

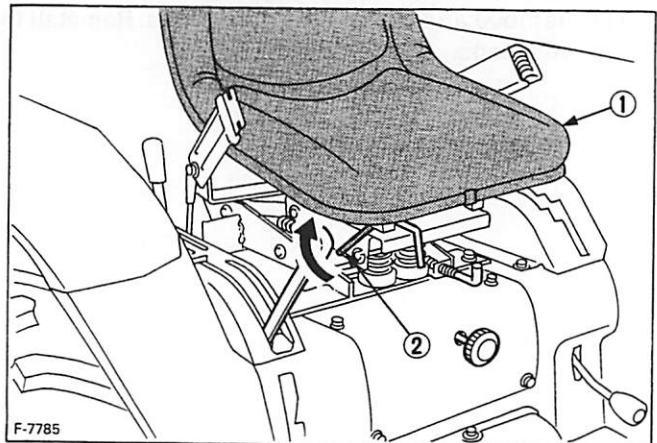

F-7785

- ① Seat
- ② Adjusting lever

IMPORTANT:

- After adjusting the operator's seat, be sure to check to see that the seat is properly locked.
- See "REVERSING THE SEAT" section when using seat in backhoe position.

Seat Belt



CAUTION

To avoid personal injury:

- Always use the seat belt while driving tractors, when the ROPS is installed. Do not use the seat belt if the tractor is not equipped with ROPS.

Adjust the seat belt after fully extended and connect to the buckle. This seat belt is non-locking retractable type.

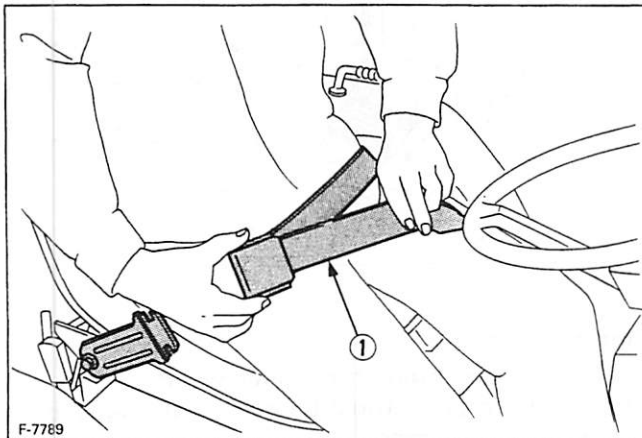

① Seat belt

Tilt Steering Adjustment



CAUTION

To avoid personal injury:

- Do not adjust the steering wheel while the tractor is in motion.
- Make sure the steering wheel is locked after adjusting.

Steering wheel is adjustable when tilt lever is unlocked.

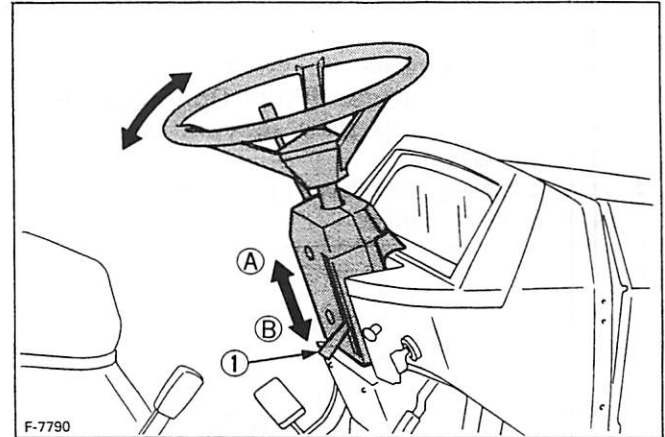

① Tilt lever

A "UNLOCK"

B "LOCK"

2. Selecting light switch positions.

Head Light Switch, Hazard Light Switch (if equipped)

- A OFF ... Head lights OFF.
- B ... Head lights ON, high beam.
- C ... Head lights dimmed, low beam.

When hazard light switch is turned to clockwise, the hazard lights blink. Hazard light indicators on the instrument panel monitor the hazard lights condition.

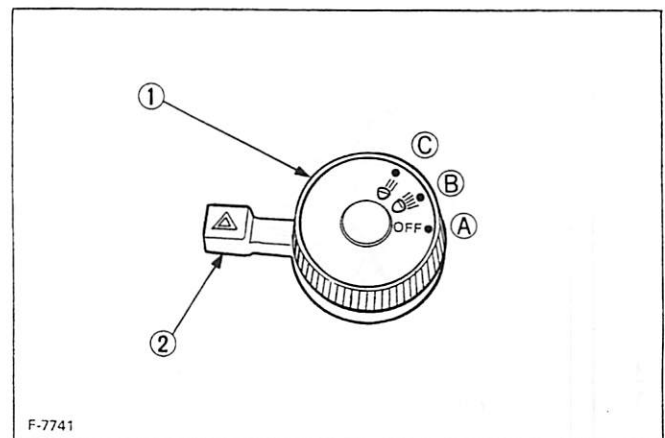

① Head light switch

② Hazard light switch

3. Checking the brake pedal.

■ Brake Pedals (Right and Left)



WARNING

To avoid personal injury:

- Applying only one rear wheel brake at high speeds could cause the tractor to swerve or roll-over.

- (1) Before operating the tractor on the road, be sure to interlock the right and left pedals as illustrated below.
- (2) Use individual brakes to assist in making sharp turns at slow speeds (Field Operation Only). Disengage the brake pedal lock and depress only one brake pedal.
- (3) Be sure brake pedals have equal adjustment when using locked together.

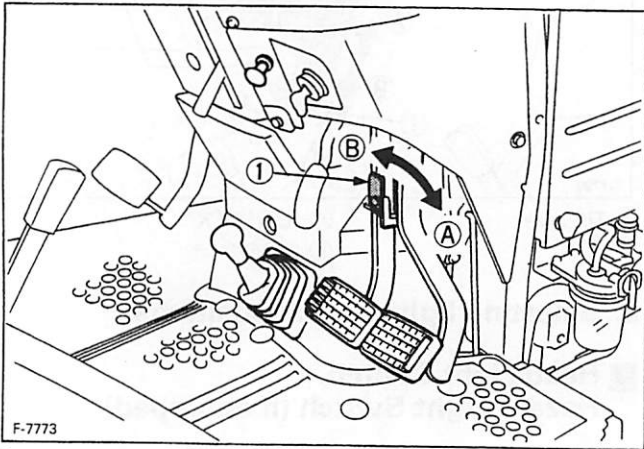

① Brake pedal lock A "LOCK"
B "RELEASE"

4. Raise the implement. (see "HYDRAULIC UNIT" section)

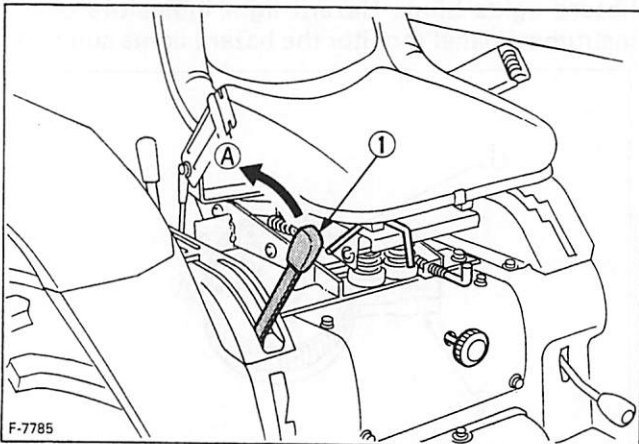

① Position control lever A "UP"

5. Depress the clutch pedal.

■ Clutch Pedal



CAUTION

To avoid personal injury:

- Sudden release of the clutch may cause the tractor to lunge in an unexpected manner.

The clutch is disengaged when the clutch pedal is fully pressed down.

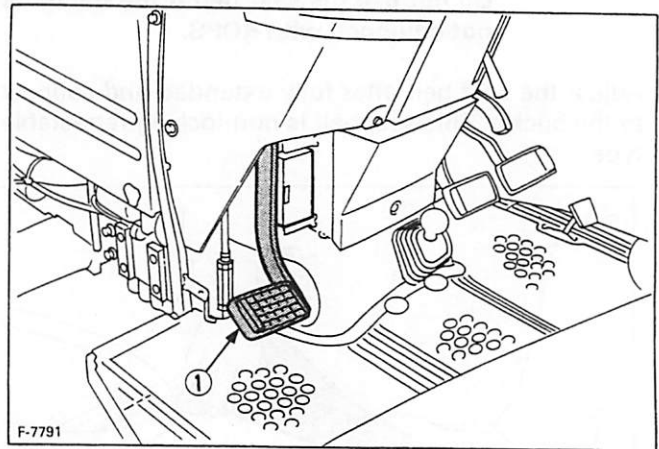

① Clutch pedal

IMPORTANT:

To help prevent premature clutch wear:

- The clutch pedal must be quickly disengaged and be slowly engaged.
- Avoid operating the tractor with your foot resting on the clutch pedal.
- Select proper gear and engine speeds depending on the type of job.

6. Selecting the travel speed.

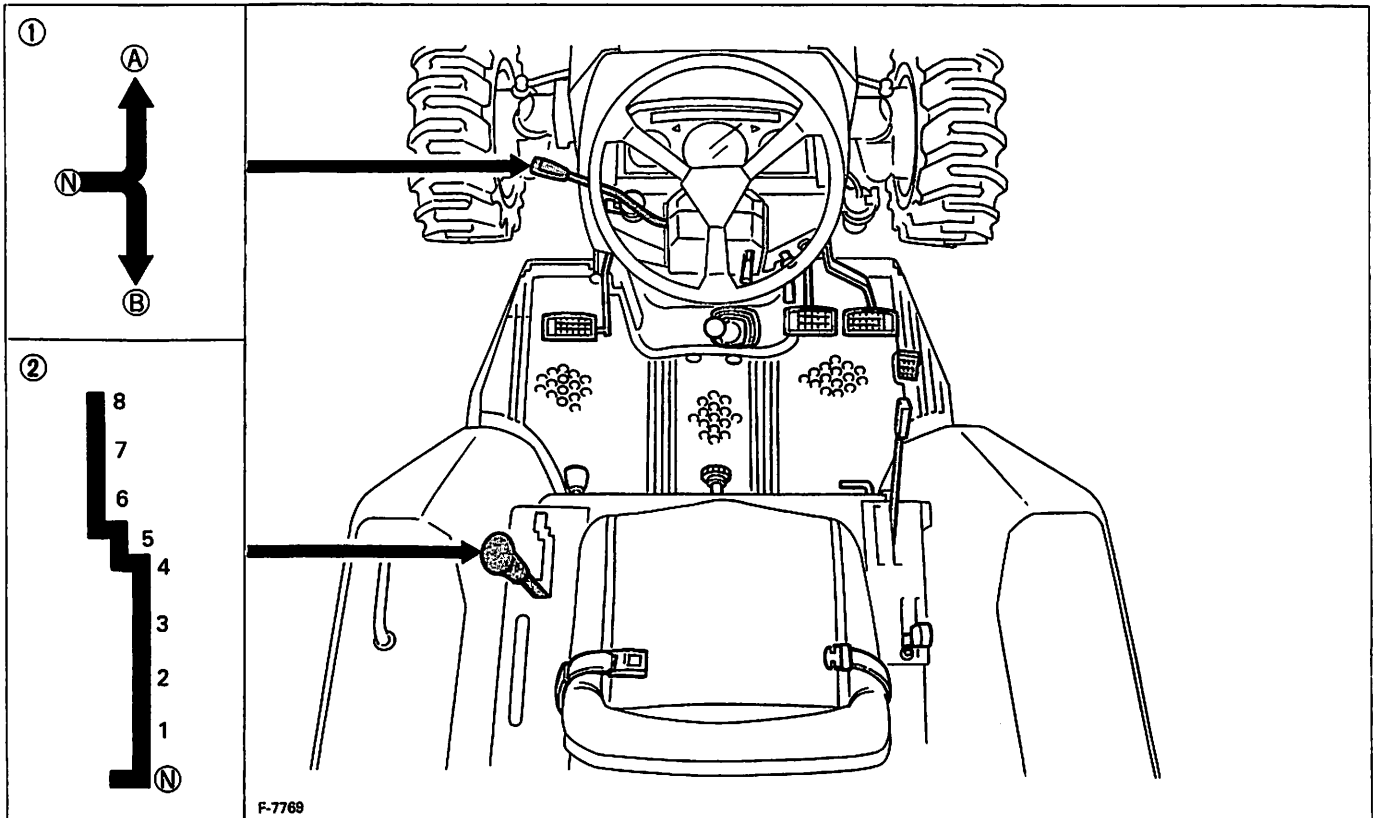

- ① Shuttle shift lever A "FORWARD"
 ② Main gear shift lever B "REVERSE"
 N "NEUTRAL POSITION"

■ Shuttle Shift Lever



WARNING
 To avoid personal injury:
BEFORE DISMOUNTING TRACTOR:

- **ALWAYS SET PARKING BRAKE**
 Leaving transmission in gear with the engine stopped will not prevent tractor with GST transmission from rolling.
- **STOP THE ENGINE AND REMOVE THE KEY**

Raise up and shift the shuttle shift lever forward to obtain forward speeds and shift it backward to obtain reverse speeds without using the clutch pedal. Tractor with glide shift transmission can obtain live PTO by moving shuttle shift lever to neutral position.

IMPORTANT:

- Reduce engine speed to low idle before shifting the shuttle shift lever.
- Shuttle shift change should not be done all at one time.
 Move the shuttle shift lever to the neutral position momentarily before you accomplish the shuttle change.

■ Main Gear Shift Lever

Main gear shift lever has NINE positions, neutral and 1st thru 8th gear. Main gear shift lever pattern is shown in the following illustration.

With the Glide Shift Transmission, you can shift at any time, stopped or on-the-go. The Shuttle Shift lever must be in forward or reverse.

There is no need to use the clutch when starting out or shifting up or down.

"Live" PTO operation can be obtained with Glide Shift Transmission tractors. Depress clutch and move PTO gear shift lever to 540 rpm. Release the clutch and the PTO will be engaged. Move Shuttle shift lever to forward or reverse. Forward or Reverse movement can now be obtained with the main gear shift lever. To stop the tractor movement without disengaging PTO, shift main gear shift lever to neutral or move shuttle shift lever to neutral and set parking brake.

The PTO continues running even if you change the traveling speed or stop the tractor.

Before dismounting tractor, shift the main gear shift lever to the neutral position and set parking brake.

IMPORTANT:

- Start in lower gears and shift one gear at a time until desired gear is obtained.
- To prolong clutch life, avoid slipping the hydraulic clutch. Pay attention to the following points:
 - Select proper gear and engine speeds depending on the type of job.
 - Avoid lugging the engine, especially in higher gears. If RPM's drop excessively, shift to a lower gear.
- In cold climate, it may take longer for the main gear shift lever to work. This is because the transmission oil must get warm enough.
 - Warm up the machine long enough. If there is not enough time to do so, start the machine with the shuttle shift lever or the clutch.
 - There is no problem with a delay in starting. The machine will start as the oil temperature goes up.



CAUTION

To avoid personal injury:

- Use the clutch when making an emergency stop or working in confined areas, such as getting tractor in position to attach an implement.
- An accident may occur with erratic shifting operation.
For safe operation, move main gear shift lever only one gear at a time.
- Shift the main gear shift lever firmly and without hesitation. Improper shift lever position will cause the tractor to momentarily coast on slopes.
- Avoid changing gears when climbing or descending a slope.
- Before ascending or descending a slope, shift to a gear low enough to control tractor speed without using brakes.
If you shift gears while ascending or descending a slope, be prepared to use the brakes to maintain control.
- Operate in reverse at slow speeds to maintain control.

STOPPING

■ Stopping

- (1) Slow the engine down.
- (2) Step on the clutch and brake pedal.
- (3) After the tractor has stopped, disengage the PTO, lower the implement, shift the transmission to neutral, release the clutch pedal, set the parking brake.

CHECK DURING DRIVING

■ Immediately Stop the Engine if:

- The engine suddenly slows down or accelerates,
- Unusual noises suddenly appear,
- Exhaust fumes suddenly become very dark,

While driving, make the following checks to see that all the parts are functioning normally.

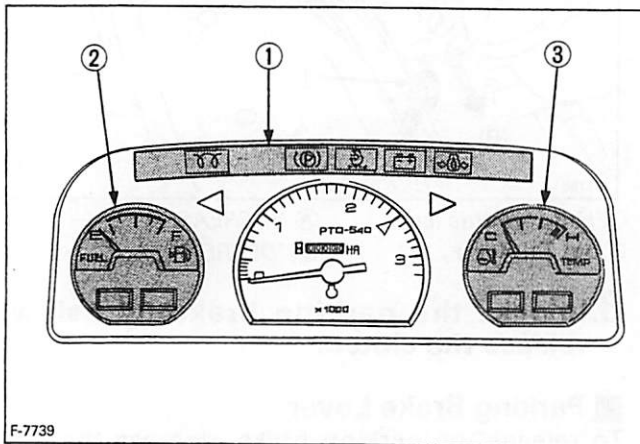

F-7739

- ① Easy checker™
- ② Fuel gauge
- ③ Coolant temperature gauge

■ Easy Checker™

If the warning lamps in the Easy Checker™ come on during operation, immediately stop the engine, and find the cause as shown below.

Never operate the tractor while Easy Checker™ lamp is on.

⚠ Engine oil pressure.

If the oil pressure in the engine goes below the prescribed level, the warning lamp in the Easy Checker™ will come on.

If this should happen during operation, and it does not go off when the engine is accelerated to more than 1000 rpm, check level of engine oil. (See "Checking Engine Oil Level" in daily check in periodic service section.)



Air cleaner.

If the air cleaner is clogged, the warning lamp in the Easy Checker™ will come on.

If this should happen during operation, clean the air cleaner element.

(See "Cleaning Air Cleaner Element" in every 100 hours in periodic service section.)



Electrical charge

If the alternator is not charging the battery, the warning lamp in the Easy Checker™ will come on.

If this should happen during operation, check the electrical charging system or consult your local KUBOTA dealer.

NOTE:

- For checking and servicing of your tractor, consult your local KUBOTA dealer for instructions.

■ Fuel Gauge

When the key switch is on, the fuel gauge indicates the fuel level.

Be careful not to empty the fuel tank. Otherwise air may enter the fuel system.

Should this happen, the system should be bled (See "Bleeding Fuel System" in as required in Periodic Service Section)

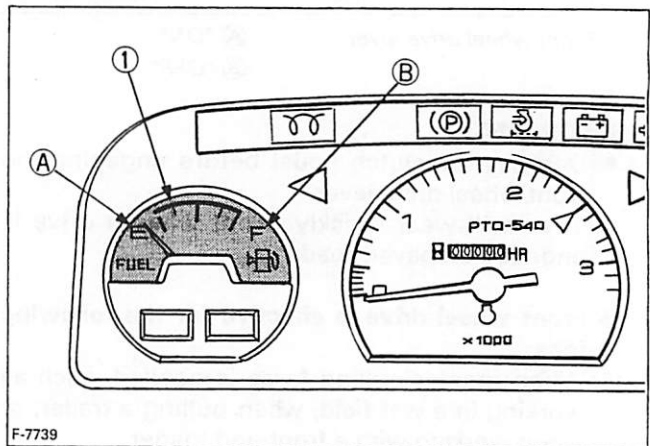

F-7739

- ① Fuel gauge
- Ⓐ "EMPTY"
- Ⓑ "FULL"

■ Coolant Temperature Gauge



CAUTION

To avoid personal injury:

- Do not remove radiator cap until coolant temperature is well below its boiling point. Then loosen cap slightly to the stop to relieve any pressure before removing cap completely.

- (1) With the key switch at "ON", this gauge indicates the temperature of the coolant. "C" for "cold" and "H" for "hot."
- (2) If the indicator reaches the "H" setting (red zone), engine coolant is overheated. Check the tractor by referring to "Troubleshooting" section.

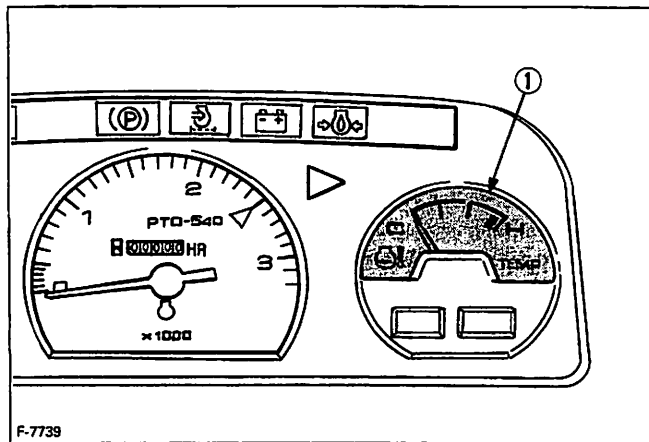

① Coolant temperature gauge

■ Hourmeter/Tachometer

This meter gives readings for engine speed, PTO shaft speed and the hours the tractor has been operated.

- (1) The tachometer shows the engine speed and corresponding PTO shaft speed.
- (2) The hourmeter indicates in five digits the hours the tractor has been used; the last digit indicates 1/10 of an hour.

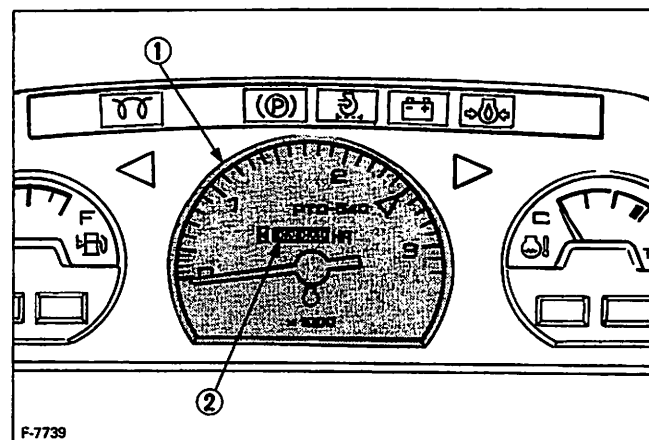

- ① Engine revolution
- ② Hours used

PARKING

■ Parking



CAUTION

To avoid personal injury:

- Always set the parking brake and stop the engine before leaving the tractor seat.

- (1) When parking, be sure to set the parking brake.
- (2) Before getting off the tractor, disengage the PTO, lower all implements, place all control levers in their neutral positions, set the parking brake, stop the engine and remove the key.
- (3) If it is necessary to park on an incline, be sure to chock the wheels to prevent accidental rolling of the machine.

OPERATING TECHNIQUES

■ Differential Lock



WARNING

To avoid personal injury:

- It is extremely dangerous to operate tractor at high speed or attempt to turn the tractor in either direction with differential lock engaged. Be sure to release the lock before making such a turn.

If one of the rear wheels should slip, step on the differential lock pedal. Both wheels will then turn together, reducing slippage.

Differential lock is maintained only while the pedal is depressed.

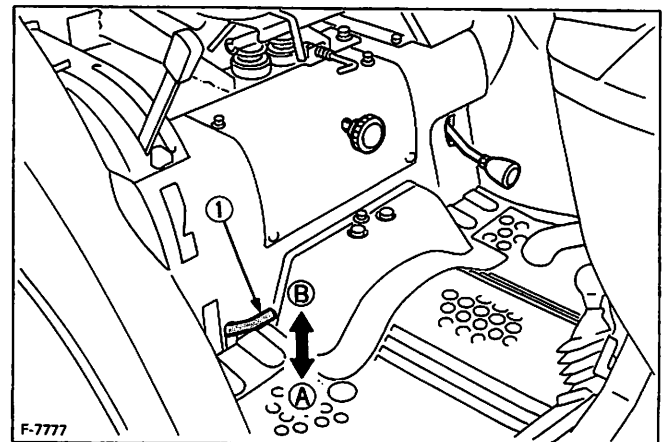

- ① Differential lock pedal
- ② A Press to "ENGAGE"
- ③ B Release to "DISENGAGE"

IMPORTANT:

- To prevent damage to power train, do not engage differential lock when one wheel is spinning and the other is completely stopped.
- When using the differential lock, always slow the engine down.
- If the differential lock cannot be released in the above manner, step lightly on the brake pedals alternately.

■ Operating the Tractor on a Road**CAUTION**

To avoid personal injury:

- To help assure straight line stops when driving at transport speeds, lock the brake pedals together. Uneven braking at road speeds could cause the tractor to roll-over.
- When traveling on road with 3-point hitch mounted implement attached, be sure to have sufficient front weight on the tractor to maintain steering ability.

Be sure SMV emblem and warning lamps are clean and visible. If towed or rear-mounted equipment obstructs these safety devices, install SMV emblem and warning lamps on equipment.

Consult your local KUBOTA dealer for further detail.

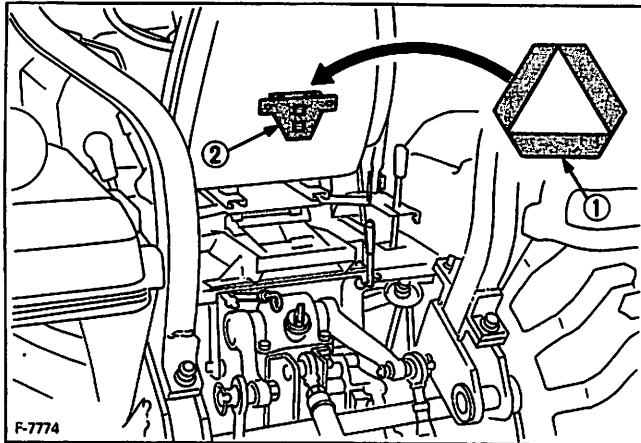

① SMV emblem

② Bracket

■ Operating on Slopes and Rough Terrain.**CAUTION**

To avoid personal injury:

- Always back up when going up a steep slope. Driving forward could cause the tractor to tip over backward. Stay off hills and slopes too steep for safe operation.
- Avoid changing gears when climbing or descending a slope.
- If operating slope, never disengage the clutch or shift levers to neutral. Doing so could cause loss of control.
- Do not drive the tractor close to the edges of ditches or banks which may collapse under the weight of the tractor. Especially when the ground is loose or wet.

- (1) Be sure wheel tread is adjusted to provide maximum stability.
(See "Wheel Adjustment" in wheels, Tires and Ballast section.)
- (2) Slow down for slopes, rough ground, and sharp turns, especially when transporting heavy, rear mounted equipment.
- (3) Before descending a slope, shift to a gear low enough to control speed without using brakes.

■ Directions for Use of Power Steering

- (1) Power steering is activated only while the engine is running. Slow engine speeds make the steering a little heavier. While the engine is stopped, the tractor functions in the same manner as tractors without power steering.
- (2) When the steering wheel is turned all the way to the stop, the relief valve is activated. Do not hold the steering wheel in this position for a long period of time.
- (3) Avoid turning the steering wheel while the tractor is stopped, or tires and rims may wear out sooner.
- (4) The power steering mechanism makes the steering easier. Be careful when driving on a road at high speeds.

REVERSING THE SEAT

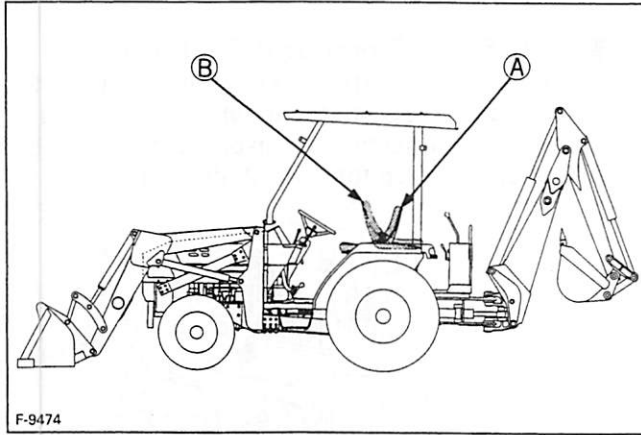

- Ⓐ "TRACTOR DRIVING POSITION"
- Ⓑ "BACKHOE POSITION"

The seat is reversible for backhoe operation. Follow the procedure below to turn the seat around.

- (1) Pull the lever forward as shown in the illustration to release the seat lock while pushing the seat.

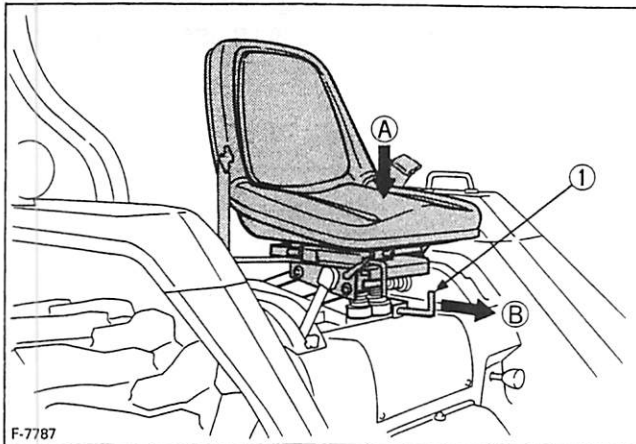

- ① Seat lock lever
- Ⓐ "PUSH"
- Ⓑ "RELEASE"

- (2) Raise the seat on top.
- (3) Twist the seat turning lever to counter-clockwise as shown in the illustration. Turn the seat around rearward and push it down for backhoe operation. The seat is automatically locked at the backhoe position.

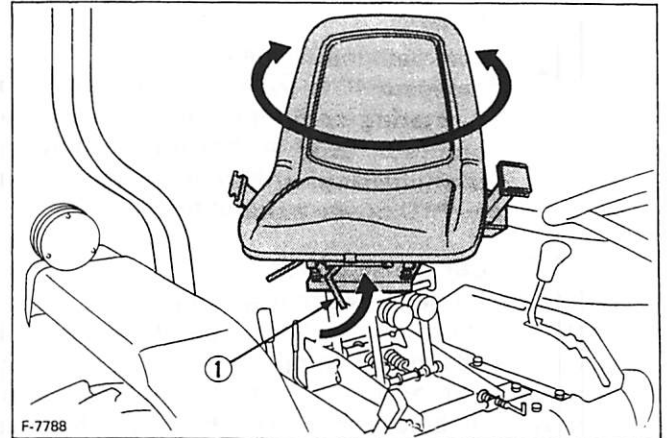

- ① Seat turning lever

IMPORTANT:

- Turn the seat at the top position to avoid damage of seat.
- See "Operator's Seat" section when using seat in driving position.

- (4) For tractor driving position, push the lever backward while pushing the seat, and follow the reverse procedure mentioned above.

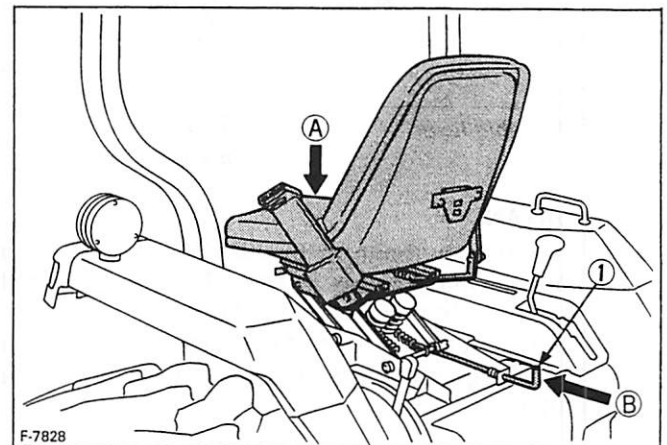

- ① Seat lock lever
- Ⓐ "PUSH"
- Ⓑ "RELEASE"

THREE-POINT HITCH & DRAWBAR

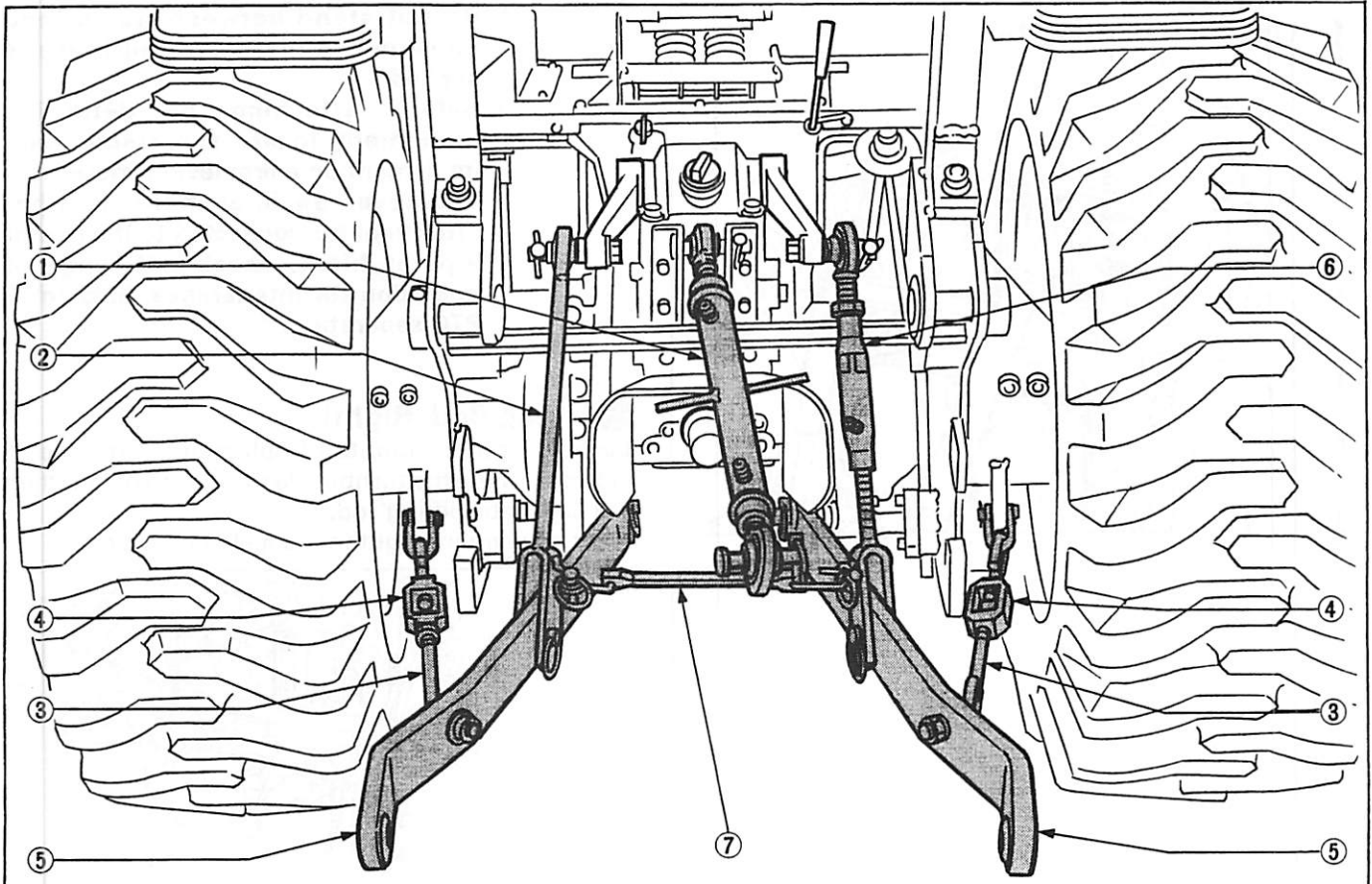

F-7770

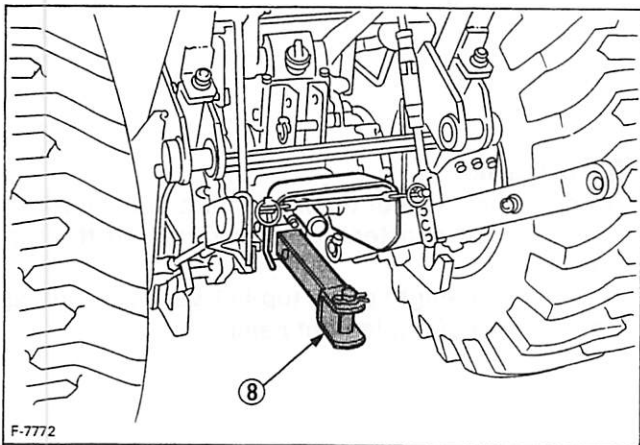

F-7772

- ① Top link
- ② Lifting rod (Left)
- ③ Check chains
- ④ Turnbuckle
- ⑤ Lower link
- ⑥ Lifting rod (Right)
- ⑦ Lower link holder
- ⑧ Fixed hitch (option)

3-POINT HITCH

1. Make preparations for attaching implement

■ Top Link Mounting Holes

Use (A) hole or (B) hole.

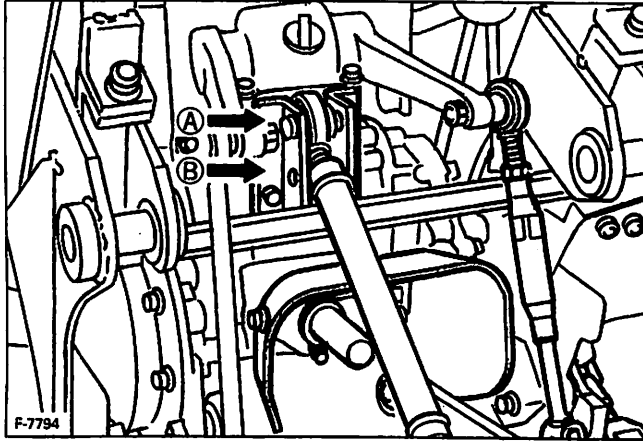

2. Attaching and detaching implements



CAUTION

To avoid personal injury:

- Be sure to stop the engine.
- Do not stand between tractor and implement unless parking brake is applied.
- Before attaching or detaching implement locate the tractor and implement on a firm level surface.
- Whenever an implement or other attachment is connected to the tractor 3-point hitch, check full range of operation for interference, binding or PTO separation.

■ Lifting Rod (Right)

Level a 3-point mounted implement from side to side by turning the turnbuckle to shorten or lengthen the adjustable lifting rod.

After adjustment, tighten the lock nut securely.

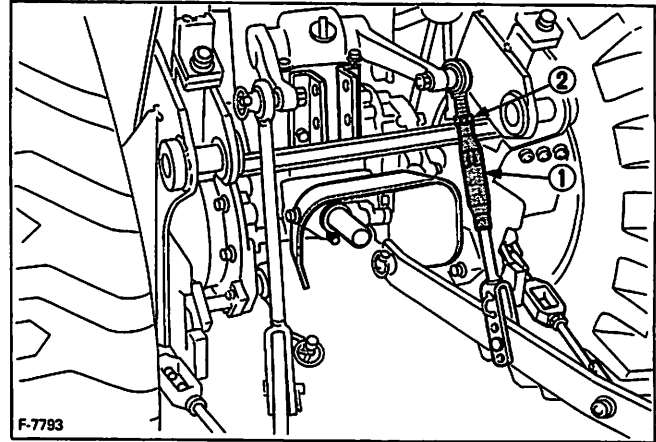

① Turnbuckle

② Lock nut

■ Top Link

(1) Adjust the angle of the implement to the desired position by shortening or lengthening the top link.

(2) The proper length of the top-link varies according to the type of implement being used.

■ Check Chains

Adjust the turn buckle to control horizontal sway of the implement.
After adjustment, retighten the lock nut.

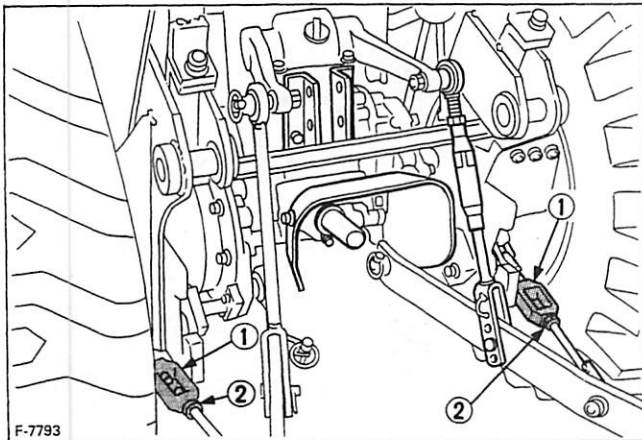

- ① Turnbuckle
- ② Lock nut

Type of implement	Chain adjustment
Plow, furrower, subsoiler, cultivator, ditcher	Loosen until the implement can be moved 50 to 60 mm (2 to 2.5 in.) horizontally.
Rotary, mower, hayrake, tedder, ridger	Tighten

■ Lower Link Holder

When operating the tractor without a 3-point hitch implement, it is necessary to lock the lower links to prevent them from hitting the tractor rear wheels.

FIXED HITCH (Option)



CAUTION

To avoid personal injury:

- Never pull from the top link, the rear axle or any point above the hitch. Doing so could cause the tractor to tip over rearward causing personal injury.

■ Adjusting Hitch Length

When towing an implement, recommend use of (A) hole in the fixed hitch.

The hitch load is referred to "IMPLEMENT LIMITATIONS" section.

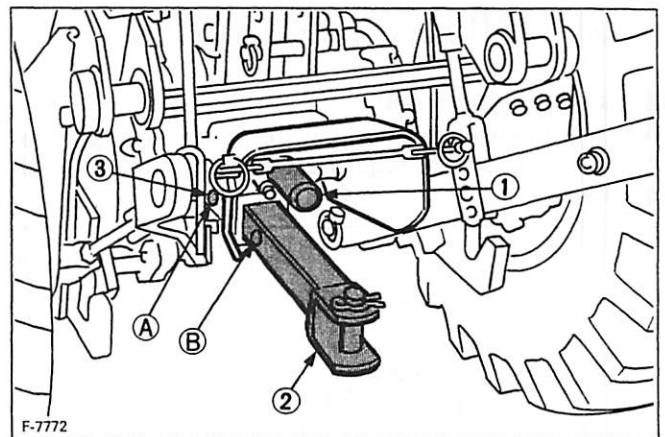

- ① PTO shaft
- ② Fixed hitch (option)
- ③ Pin

Holes : (A), (B)

IMPORTANT

- When mounting the BT900 Backhoe, take off the fixed hitch ②.

HYDRAULIC UNIT

IMPORTANT

- Do not operate until the engine is warmed up. If operation is attempted when the engine is still cold, the hydraulic system may be damaged.
- If noises are heard when implement is lifting after the hydraulic control lever has been activated, the hydraulic mechanism is not adjusted properly. Unless corrected the unit will be damaged. Contact your KUBOTA dealer for adjustment.

3-POINT HITCH CONTROL SYSTEM

Position Control

This will control the working depth of 3-point hitch mounted implement regardless of the amount of pull required.

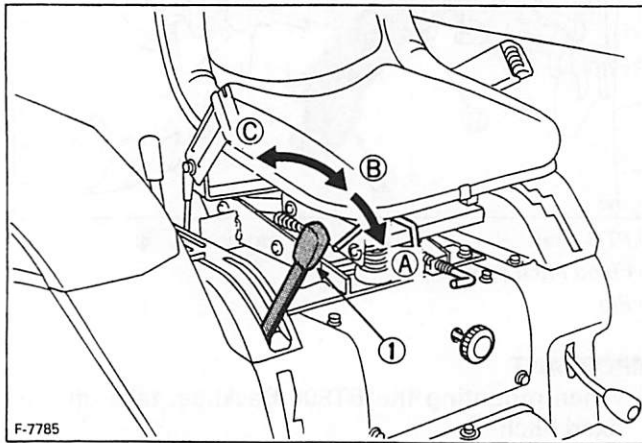

- ① Position control lever
- A "FLOAT"
 - B "DOWN"
 - C "UP"

3-point Hitch Lowering Speed



CAUTION

To avoid personal injury:

- Fast lowering speed may cause damage or injury. Lowering speed of implement should be adjusted to two or more seconds.

The lowering speed of the 3-point hitch can be controlled by adjusting the 3-point lowering speed knob.

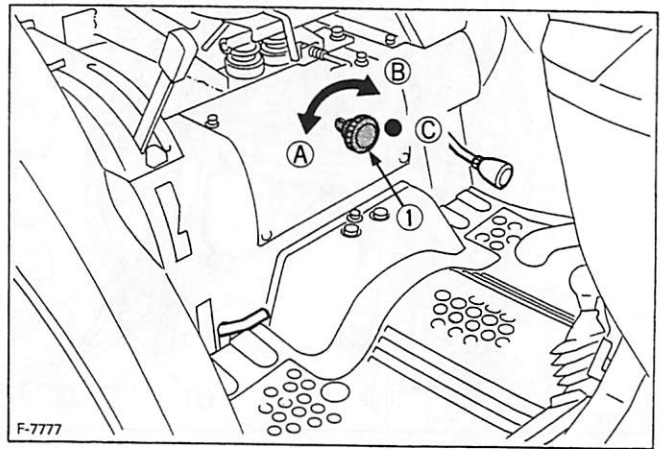

- ① 3-Point lowering speed knob
- A "FAST"
 - B "SLOW"
 - C "LOCK"

Directional Valve

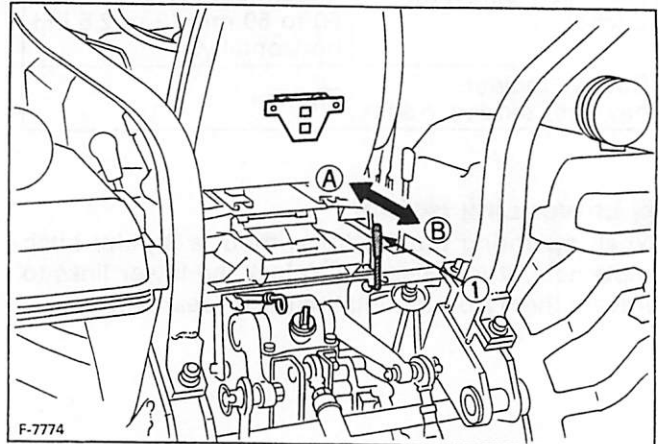

- ① Directional valve lever
- A "TO USE BACKHOE"
 - B "TO USE 3-POINT HITCH"

When using BT900 Backhoe, push the directional valve lever forward. If not, the hydraulic temperature rises. When using 3-point hitch, pull the directional valve lever rearward completely.

IMPORTANT:

- If the lever is not at "3-POINT HITCH POSITION B", 3-point hitch does not move.

TIRES, WHEELS AND BALLAST

TIRES



WARNING

To avoid personal injury:

- Do not attempt to mount a tire. This should be done by a qualified person with the proper equipment.
- Always maintain the correct tire pressure.

Do not inflate tires above the recommended pressure shown in the operator's manual.

IMPORTANT:

- Do not use tires larger than specified.
- When you intend to mount different size of tires from equipped ones, consult your dealer about front drive gear ratio for detail.
Excessive wear of tires may occur due to improper gear ratio.

Inflation Pressure

Though the tire pressure is factory-set to the prescribed level, it naturally drops slowly in the course of time. Thus, check it everyday and inflate as necessary.

Front	27×10.5—15	275 kPa (2.8 kgf/cm ² , 40 psi)
Rear	15—19.5	207 kPa (2.1 kgf/cm ² , 30 psi)

Treads

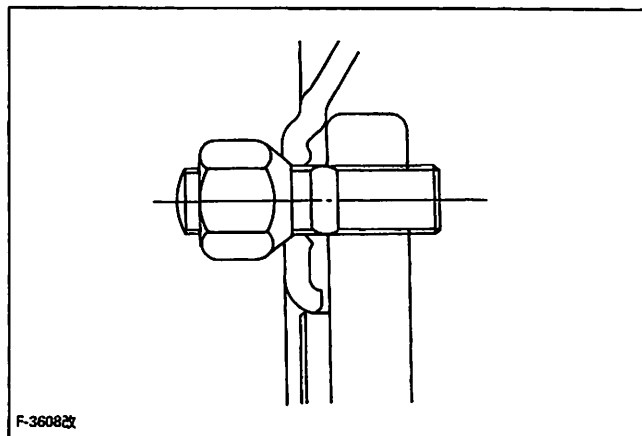
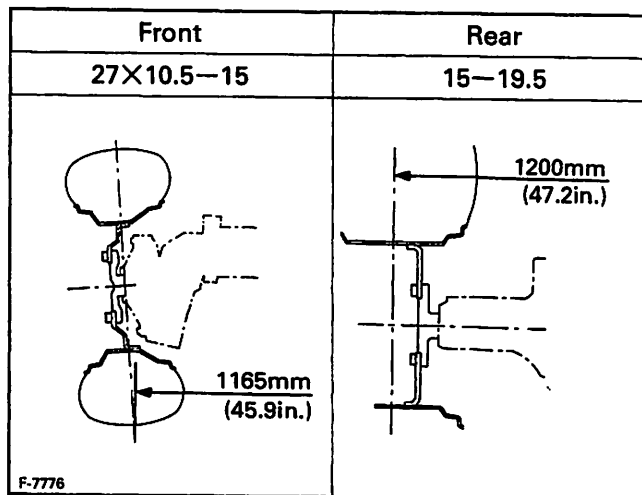

NOTE:

- Front wheels with beveled or tapered holes:
Use the tapered side of lug nut.

IMPORTANT:

- Always attach tires as shown in the above illustration.
- If not attached as illustrated, transmission parts may be damaged.
- Do not use tires larger than specified.

BALLAST



CAUTION

To avoid personal injury:

- Additional ballast will be needed for transporting heavy implements. When the implement is raised, drive slowly over rough ground, regardless of how much ballast is used.
- Do not fill the front wheel with liquid to maintain steering control.

Front Ballast

Heavy pulling and heavy rear mounted implements tend to lift front wheels. Therefore do not remove the loader from the tractor at all times to maintain steering control and prevent tip over.

Rear Ballast

Add weight to rear wheels if needed to improve traction or for stability. The amount of rear ballast should be matched to job and the ballast should be removed when it is not needed.

The weight should be added to the tractor in the form of liquid ballast.

- When the BT900 backhoe is installed to the tractor, rear ballast should be removed.

Liquid Ballast in Rear Tires

Water and calcium chloride solution provides safe economical ballast. Used properly, it will not damage tires, tubes or rims. The addition of calcium chloride is recommended to prevent the water from freezing. Use of this method of weighting the wheels has the full approval of the tire companies. See your tire dealer for this service.

Liquid weight per tire (75 Percent filled)

Tire sizes	15-19.5
Slush free at -10°C (14°F) Solid at -30°C (-22°F) [Approx. 1 kg (2 lbs.) CaCl ₂ per 4 ℓ (1 gal) of water]	142 kg (314 lbs.)
Slush free at -24°C (-11°F) Solid at -47°C (-52°F) [Approx. 1.5 kg (3.5 lbs.) CaCl ₂ per 4 ℓ (1 gal) of water]	149 kg (329 lbs.)
Slush free at -47°C (-52°F) Solid at -52°C (-62°F) [Approx. 2.25 kg (5 lbs.) CaCl ₂ per 4 ℓ (1 gal) of water]	159 kg (350 lbs.)

IMPORTANT:

- Do not fill tires with water or solution more than 75% of full capacity (to the valve stem level).

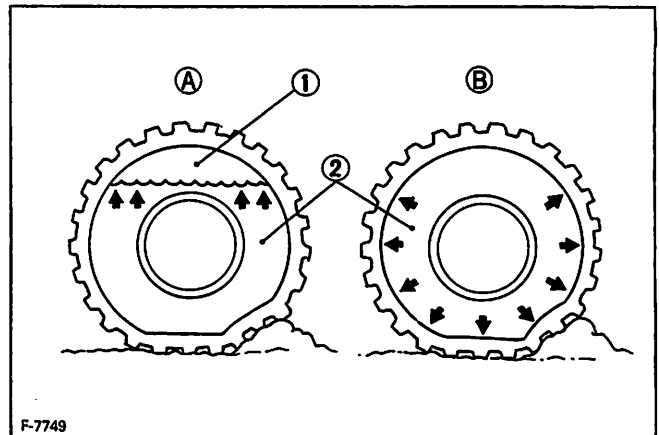

- ① Air A Correct-75% Air compresses like a cushion
- ② Water B Incorrect-100% Full Water can not be compressed

MAINTENANCE

SERVICE INTERVALS

No.	Items	Period	Indication on hour meter																Since then	Refer- ence page
			50	100	150	200	250	300	350	400	450	500	550	600	650	700	750	800		
1	Engine oil	Change	⊙	○		○		○		○		○		○		○		○	every 100 Hr	45
2	Engine oil filter	Replace	⊙			○				○								○	every 200 Hr	48
3	Hydraulic oil filter	Replace	⊙			○				○								○	every 200 Hr	49
4	Transmission fluid	Change	⊙							○								○	every 400 Hr	51
5	Front axle case oil	Change	⊙							○								○	every 400 Hr	51
6	Front axle pivot	Adjust	⊙							○								○	every 400 Hr	52
7	Greasing		○	○	○	○	○	○	○	○	○	○	○	○	○	○	○	○	every 50 Hr	42
8	Engine start system	Check	○	○	○	○	○	○	○	○	○	○	○	○	○	○	○	○	every 50 Hr	43
9	Wheel bolt torque	Check	○	○	○	○	○	○	○	○	○	○	○	○	○	○	○	○	every 50 Hr	43
10	Battery condition	Check	○	○	○	○	○	○	○	○	○	○	○	○	○	○	○	○	every 50 Hr	44
11	Air cleaner element	Clean		○		○		○		○		○		○		○		○	every 100 Hr *	46
		Replace																	every 1 year	52
12	Fuel filter element	Clean		○		○		○		○		○		○		○		○	every 100 Hr	46
		Replace								○								○	every 400 Hr	51
13	Fan belt	Adjust		○		○		○		○		○		○		○		○	every 100 Hr	47
14	Clutch	Adjust		○		○		○		○		○		○		○		○	every 100 Hr	47
15	Brake	Adjust		○		○		○		○		○		○		○		○	every 100 Hr	48
16	Radiator hose and clamp	Check				○				○								○	every 200 Hr	49
		Replace																	every 2 years	53
17	Power steering oil line	Check				○				○								○	every 200 Hr	50
		Replace																	every 2 years	53
18	Fuel line	Check				○				○								○	every 200 Hr	50
		Replace																	every 2 years	53
19	Toe-in	Adjust				○				○								○	every 200 Hr	50
20	Engine valve clearance	Adjust																○	every 800 Hr **	52
21	Cooling system	Flush																	every 2 years	52
22	Coolant	Change																	every 2 years	52
23	Fuel system	Bleed																		54
24	Clutch housing water	Drain																	Service as required	54
25	Fuse	Replace																		54
26	Light bulb	Replace																		55

IMPORTANT

● The jobs indicated by ⊙ must be done by all means 50 hours after the break-in respectively.

* Air cleaner should be cleaned more often in dusty conditions than in normal conditions.

** Consult your local KUBOTA dealer for this service.

LUBRICANTS

No.	Locations	Capacities		Lubricants						
		L35								
1	Fuel	35 ℓ (9.2 U.S.gals.)		No.2-D diesel fuel No.1-D diesel fuel if temperature is below -10°C (14°F)						
2	Coolant	7.0 ℓ (7.4 U.S.qts.)		Fresh clean water with anti-freeze						
3	Engine crankcase	4.8 ℓ (5.1 U.S.qts.)		<ul style="list-style-type: none"> ● Engine oil: API Service Classification CC or CD <table border="1"> <tr> <td>Above 25°C (77°F)</td> <td>SAE30, SAE10W-30 or 10W-40</td> </tr> <tr> <td>0~25°C (32~77°F)</td> <td>SAE20, SAE10W-30 or 10W-40</td> </tr> <tr> <td>Below 0°C (32°F)</td> <td>SAE10W, SAE10W-30 or 10W-40</td> </tr> </table>	Above 25°C (77°F)	SAE30, SAE10W-30 or 10W-40	0~25°C (32~77°F)	SAE20, SAE10W-30 or 10W-40	Below 0°C (32°F)	SAE10W, SAE10W-30 or 10W-40
Above 25°C (77°F)	SAE30, SAE10W-30 or 10W-40									
0~25°C (32~77°F)	SAE20, SAE10W-30 or 10W-40									
Below 0°C (32°F)	SAE10W, SAE10W-30 or 10W-40									
4	Transmission case	39 ℓ (41.2 U.S.qts.)		● KUBOTA UDT or SUPER UDT fluid*						
5	Front axle case [4WD]	5.5 ℓ (5.8 U.S.qts.)		● KUBOTA UDT or SUPER UDT fluid or SAE80 · SAE90 gear oil						
6	Greasing	No. of greasing point		Capacity	Type of grease					
	Steering Lever	1		Until grease overflows.	Multipurpose type grease					
	Top link	2								
	Lifting rod	1								
	Battery terminal	2		moderate amount						
	Seat adjuster	—		moderate amount						
	Reversible seat	—		moderate amount						

NOTE:

*KUBOTA UDT or SUPER UDT fluid.....KUBOTA original transmission hydraulic fluid.

NOTE:

- Engine Oil:
Oil used in the engine should have an American Petroleum Institute (API) service classification and Proper SAE Engine Oil according to the ambient temperatures as shown above:
- Transmission oil:
The oil used to lubricate the transmission is also used as hydraulic fluid. To insure proper operation of the hydraulic system and complete lubrication of the transmission, it is important that a multi-grade transmission fluid be used in this system. We recommend the use of **KUBOTA SUPER UDT fluid** for optimum protection and performance. (Consult your local KUBOTA dealer for further detail.)
Do not mix different brands together.
- Indicated capacity of water and oil are manufacture's estimate.

PERIODIC SERVICE

HOW TO OPEN THE HOOD



CAUTION

To avoid personal injury from contact with moving parts;

- Never open the front grill or engine side cover while the engine is running.
- Do not touch muffler or exhaust pipes while they are hot; Severe burns could result.

Engine Side Cover and Front Grill

- (1) To remove the front grill, twist the pin to vertical position.
- (2) To remove the engine side cover, loose knob bolt completely, and then lift the engine side cover off.

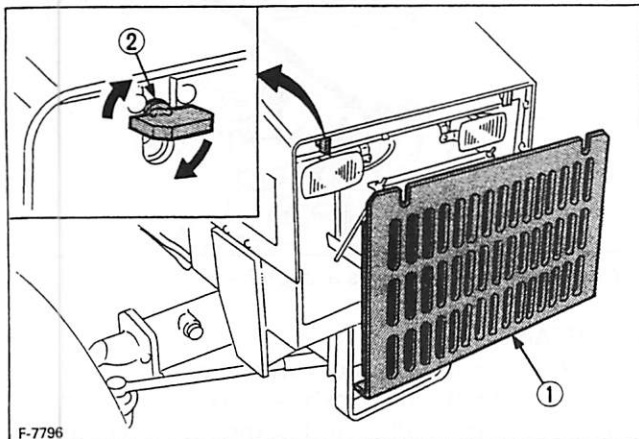

F-7796

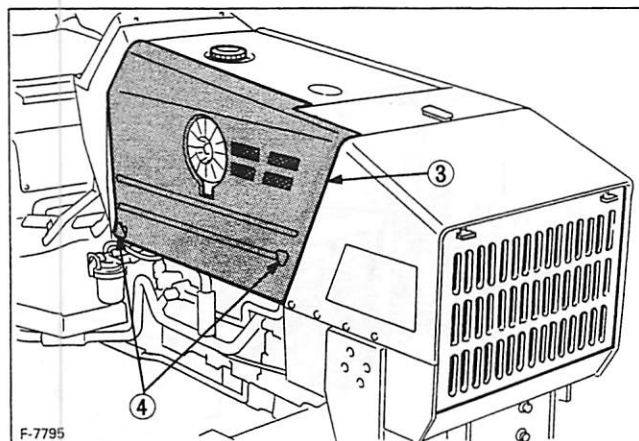

F-7795

- ① Front grill
- ② Pin
- ③ Engine side cover
- ④ Knob bolt

DAILY CHECK

For your own safety and maximum service life of the machine, make a thorough daily inspection before operating the machine to start the engine.



CAUTION

To avoid personal injury:

- Be sure to check and service the tractor on a flat place with the engine shut off and the parking brake "ON".

Walk Around Inspection

Look around and under the tractor for such items as loose bolts, trash build-up, oil or coolant leaks, broken or worn parts.

Checking and Refueling



CAUTION

To avoid personal injury:

- Do not smoke while refueling.
- Be sure to stop the engine before refueling.

- (1) Turn the key switch to "ON", check the amount of fuel by fuel gauge.
- (2) Fill fuel tank when fuel gauge shows 1/4 or less fuel in tank.
- (3) Use grade No.2-Diesel fuel at temperatures above -10°C (14°F).
Use grade No.1-Diesel fuel at temperatures below -10°C (14°F).

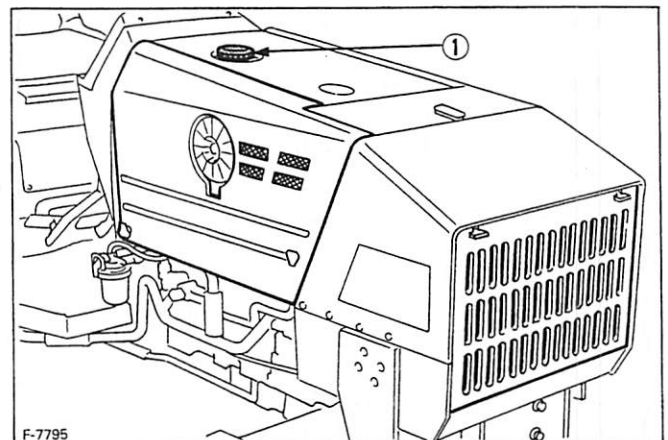

F-7795

- ① Fuel tank cap

Fuel tank capacity	35 ℓ (9.2 U.S.gals.)
--------------------	----------------------

IMPORTANT:

- Do not permit dirt or trash to get into the fuel system.
- Be careful not to let the fuel tank become empty, or air can enter the fuel system, necessitating bleeding before next engine start.
- Be careful not to spill during refueling. If should spill, wipe it off at once, or it may cause a fire.

NOTE:

No.2-D is a distillate fuel of lower volatility for engines in industrial and heavy mobile service.
(SAE J313 JUN87)

Grade of Diesel Fuel Oil According to ASTM D975

Flash Point, °C (°F)	Water and Sediment, volume %	Carbon Residue on, 10 percent Residuum, %	Ash, weight %
Min	Max	Max	Max
52 (125)	0.05	0.35	0.01

Distillation Temperatures, °C (°F) 90% Point		Viscosity Kinematic cSt or mm ² /s at 40°C		Viscosity Saybolt, SUS at 100°F		Sulfur, weight %	Copper Strip Corrosion	Cetane Number
Min	Max	Min	Max	Min	Max	Max	Max	Min
282 (540)	338 (640)	1.9	4.1	32.6	40.1	0.50	No.3	40

Checking Engine Oil Level



CAUTION

To avoid personal injury:

- Be sure to stop the engine before checking the oil level.

- (1) Park the machine on a flat surface.
- (2) Check engine oil before starting the engine or 5 minutes or more after the engine has stopped.
- (3) To check the oil level, draw out the dipstick, wipe it clean, replace it, and draw it out again. Check to see that the oil level lies between the two notches. If the level is too low, add new oil to the prescribed level at the oil inlet.

(See "LUBRICANTS" in Maintenance Section)

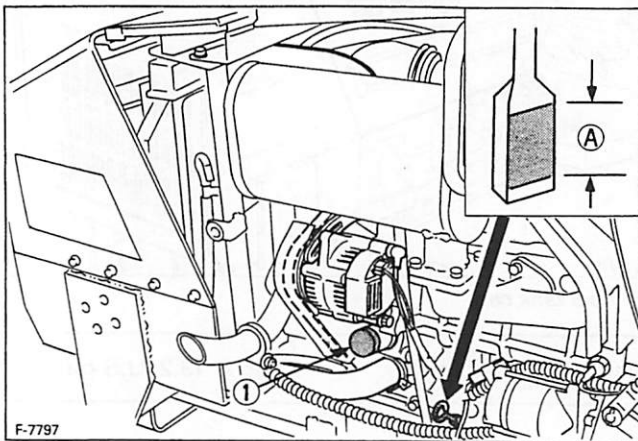

① Oil inlet A Oil level is acceptable within this range.

IMPORTANT:

- When using an oil of different maker or viscosity from the previous one, remove all of the old oil. Never mix two different types of oil.
- If oil level is low, do not run engine.

Checking Transmission Fluid Level

- (1) Park the machine on a flat surface, lower the implement and shut off engine.
- (2) To check the oil level, draw out the dipstick, wipe it clean, replace it, and draw it out again. Check to see that the oil level lies between the two notches. If the level is too low, add new oil to the prescribed level at the oil inlet.

(See "LUBRICANTS" in Maintenance Section)

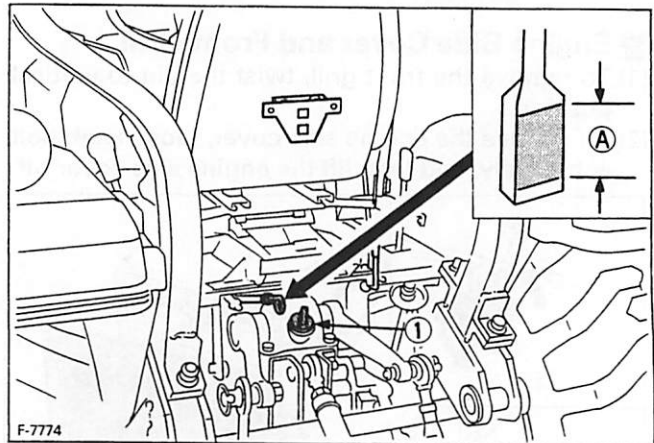

① Oil inlet A Oil level is acceptable within this range.

IMPORTANT:

- If oil level is low, do not run engine.
- When using BT900 Backhoe and checking oil level, locate the tractor/loader/backhoe on a flat and set the loader/backhoe as illustrated below.

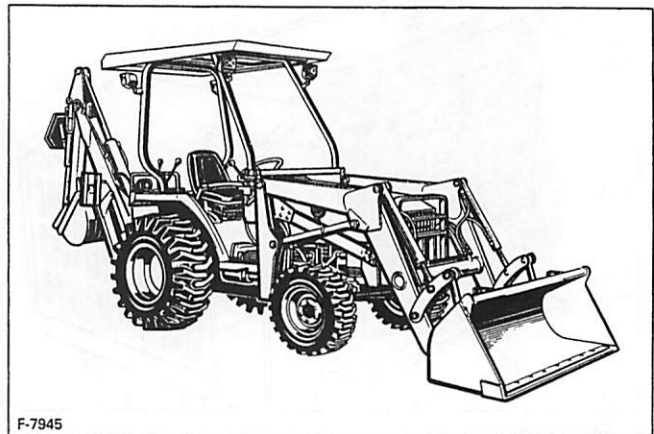

F-7945

■ Checking Coolant Level



CAUTION

To avoid personal injury:

- Do not remove the radiator cap when the engine is hot. Then loosen cap slightly to the stop to relieve any excess pressure before removing cap completely.

- (1) Check to see that the coolant level is between the "FULL" and "LOW" marks of recovery tank.
- (2) When the coolant level drops due to evaporation, add water only up to the full level.
In case of leakage, add anti-freeze and water in the specified mixing ratio up to the full level.
(See "Flush Cooling System and Changing Coolant" in every 2 years maintenance.)

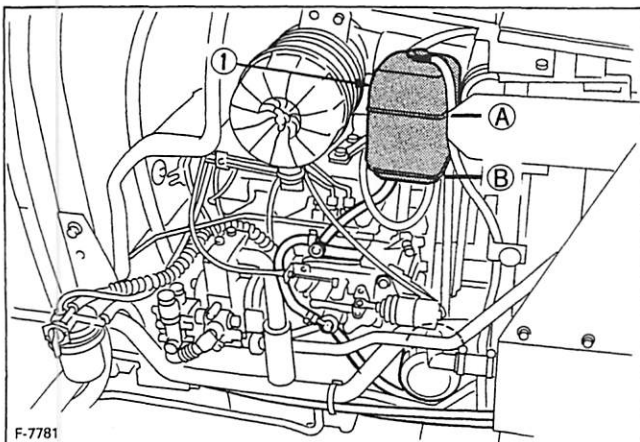

① Recovery tank

A "FULL"

B "LOW"

IMPORTANT:

- If the radiator cap has to be removed, follow the caution above and securely retighten the cap.
- Use clean, fresh water and anti-freeze to fill the recovery tank.
- If water should be leak, consult your local KUBOTA dealer.

■ Cleaning Grill and Radiator Screen



CAUTION

To avoid personal injury:

- Be sure to stop the engine before removing the screen.

- (1) Check front grill and side screens to be sure they are clean from debris.
- (2) Detach the screen and remove all the foreign material.

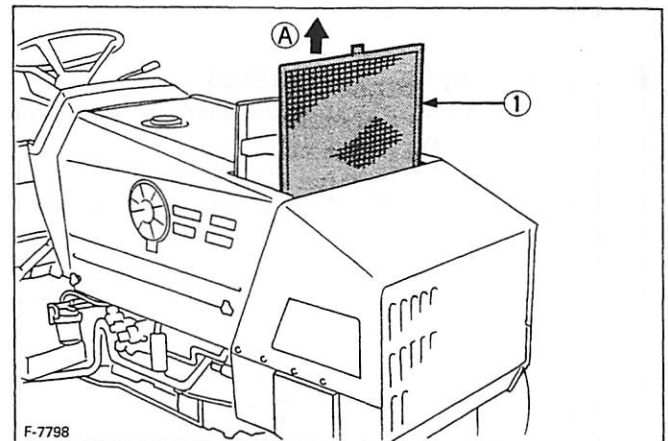

① Radiator screen

A "DETACH"

IMPORTANT:

- Grill and screen must be clean from debris to prevent engine from overheating and to allow good air intake for air cleaner.

■ Checking Brake Pedals and Clutch Pedal

- (1) Inspect the brake and clutch pedals for free travel, and smooth operation.
- (2) Adjust if incorrect measurement is found:
(See "Adjusting Clutch and Brake Pedal" in every 100 hours maintenance.)

NOTE:

- Brake pedals should be equal when depressed.

■ Checking Gauges, Meter and Easy Checker™

- (1) Inspect the instrument panel for broken gauge(s), meter(s) and Easy Checker™ lamps.
- (2) Replace if broken.

■ Checking Head Light, Hazard Light etc.

- (1) Inspect the lights for broken bulbs and lenses.
- (2) Replace if broken.

■ Checking Seat Belt and ROPS

- (1) Always check condition of seat belt and ROPS attaching hardware before operating tractor.
- (2) Replace if damaged.

EVERY 50 HOURS

■ Lubricating Grease Fittings

Apply a small amount of multipurpose grease to the following points every 50 hours:

If you operated the machine in extremely wet and muddy conditions, lubricate grease fittings more often.

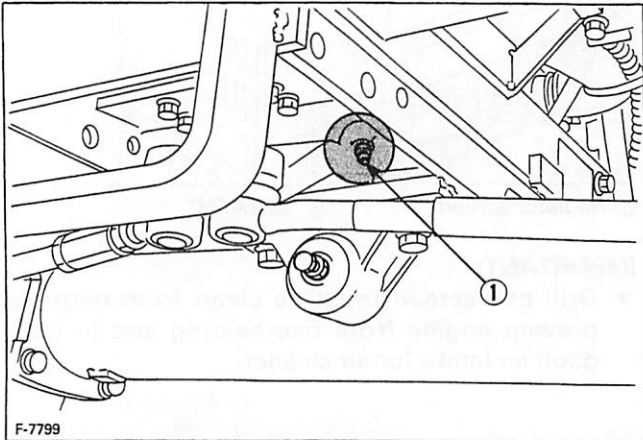

F-7799

① Grease fitting (Steering lever)

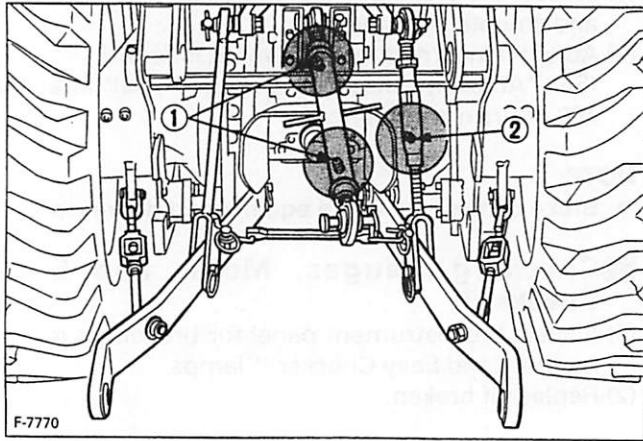

F-7770

① Grease fitting (Top link)
② Grease fitting (Lifting rod) [RH]

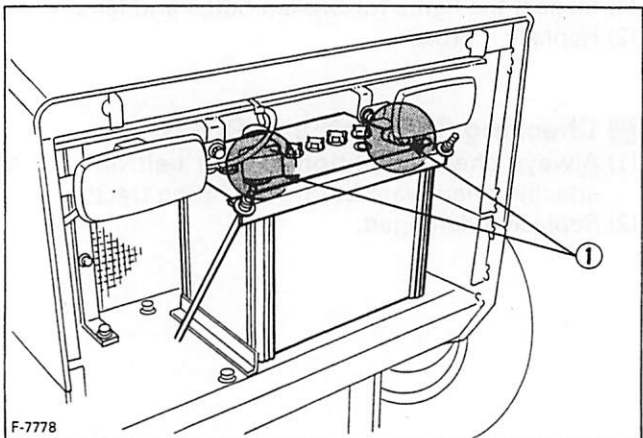

F-7778

① Battery terminals

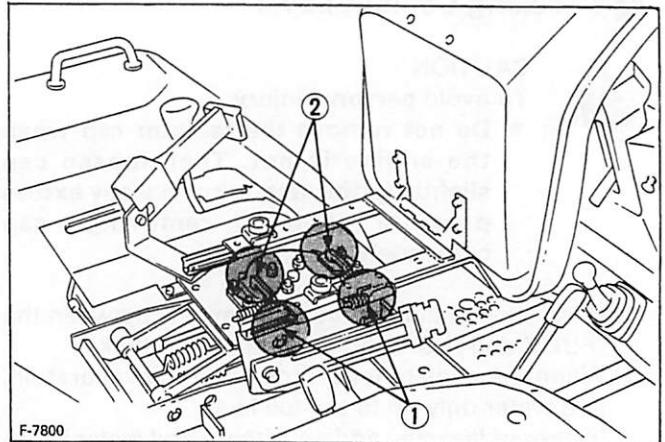

F-7800

① Seat adjuster
② Reversible seat

■ Checking Engine Start System



CAUTION

To avoid personal injury:

- Do not allow anyone near the tractor while testing.
- If the tractor does not pass the test do not operate the tractor.

◆ Preparation before testing.

1. Place all control levers in the "NEUTRAL" position.
2. Set the parking brake and stop the engine.

◆ Test 1 : Switch for the shuttle shift lever.

1. Sit on operator's seat.
2. Shift the shuttle shift lever to the forward or reverse position.
3. Depress the clutch pedal fully.
4. Disengage the PTO gear shift lever.
5. Pull out the engine stop knob and turn the key to "START" position.
6. The engine must not crank.
7. If it cranks, consult your local KUBOTA dealer for this service.

◆ Test 2 : Switch for the PTO gear shift lever.

1. Sit on operator's seat.
2. Engage the PTO gear shift lever.
3. Depress the clutch pedal fully.
4. Shift the shuttle shift lever to the neutral position.
5. Pull out the engine stop knob and turn the key to "START" position.
6. The engine must not crank.
7. If it cranks, consult your local KUBOTA dealer for this service.

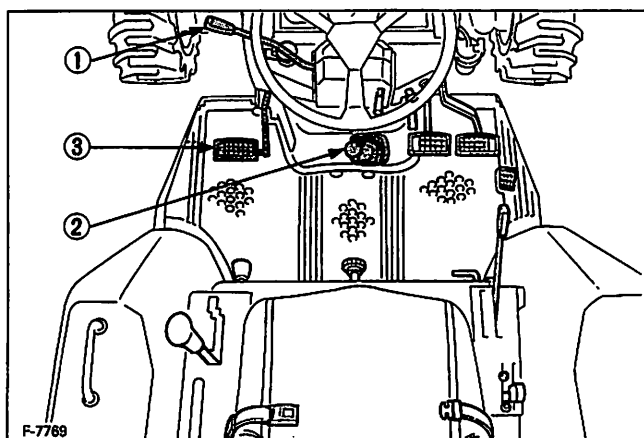

- ① Shuttle shift lever
- ② PTO gear shift lever
- ③ Clutch pedal

■ Checking Wheel Bolt Torque



CAUTION

To avoid personal injury:

- Never operate tractor with a loose rim, wheel, or axle.
- Any time bolts and nuts are loosened, retighten to specified torque.
 - Check all bolts and nuts frequently and keep them tight.

Check wheel bolts and nuts regularly especially when new. If there are loosened, tighten as follows.

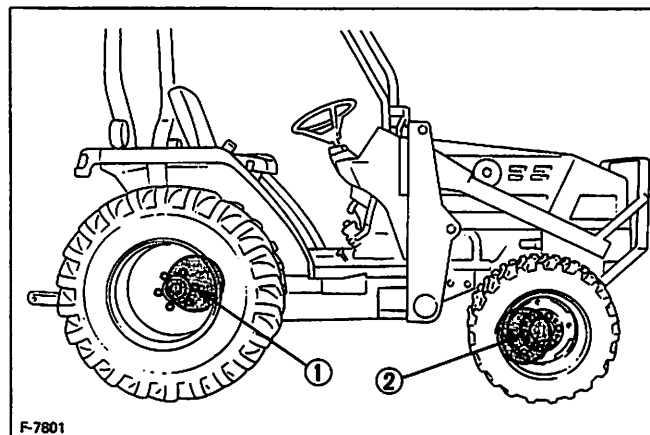

- ① 215 N·m (22kgf·m, 160ft·lbs)
- ② 137 N·m (14kgf·m, 100ft·lbs)

BATTERY



CAUTION

To avoid personal injury:

- Never remove the vent plugs while the engine is running.
- Keep electrolyte away from eyes, hands and clothes. If you are splattered with it, wash it away completely with water immediately and get medical attention.
- Wear eye protection and rubber gloves when working around battery.

Mishandling the battery shortens the service life and adds to maintenance costs.

The original battery is maintenance free type battery, but need some servicing.

If the battery is weak, the engine is difficult to start and the lights become dim. It is important to check the battery periodically.

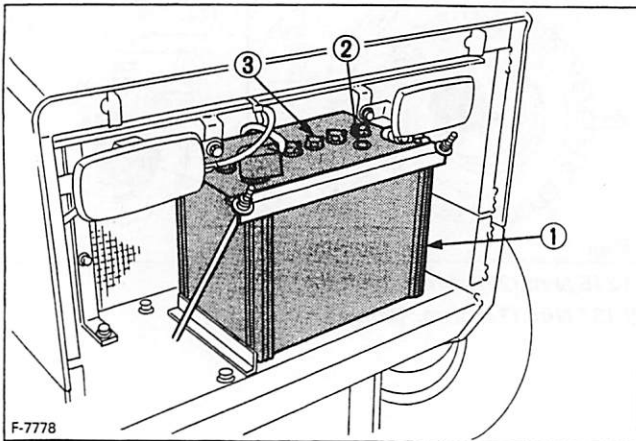

- ① Battery
- ② Indicator
- ③ Vent plug

How to read the indicator

Check the battery condition by reading the indicator.

State of indicator display

Blue: Specific gravity of electrolyte and quantity of electrolyte are both in good condition

White: Needs inspecting (Sequence of inspection):

- (1) Add only distilled water if the electrolyte level is low. (Proper level is shown in Fig.1) You can start work again if the indicator display turns to blue. Charge battery if the indicator display remains white. (Normal charging rate is shown in table 1)
- (2) Charge battery if the electrolyte level is normal.

Battery Charging



CAUTION

To avoid personal injury:

- When the battery is being activated, hydrogen and oxygen gases in the battery are extremely explosive. Keep open sparks and flames away from the battery at all times, especially when charging the battery.
- When charging battery, remove battery vent plugs.
- When disconnecting the cable from the battery, start with the negative terminal first. When connecting the cable to the battery, start with the positive terminal first.
- Never check battery charge by placing a metal object across the posts. Use a voltmeter or hydrometer.

- (1) Make sure each electrolyte level is to the bottom of vent wells, if necessary add distilled water in a well-ventilated area.

Fig. 1

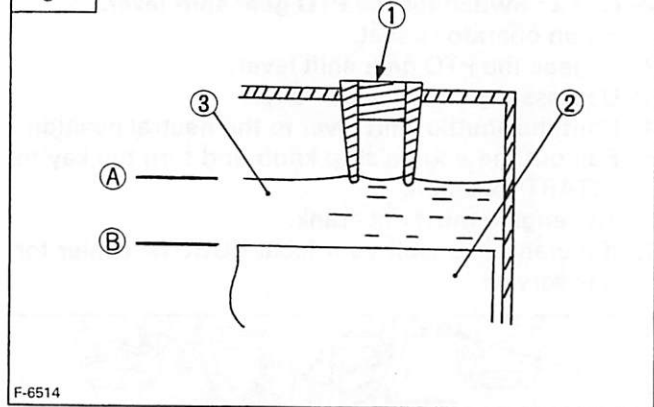

- ① Vent well
- ② Separator
- ③ Electrolyte
- (A) Highest level
- (B) Lowest level

- (2) The water in the electrolyte evaporates during recharging. Liquid shortage damages the battery. Excessive liquid spills over and damages the tractor body.
- (3) To slow charge the battery, connect the battery positive terminal to the charger positive terminal and the negative to the negative, then recharge in the standard fashion.
- (4) A boost charge is only for emergencies. It will partially charge the battery at a high rate and in a short time. When using a boost-charged battery, it is necessary to recharge the battery as early as possible. Failure to do this will shorten the battery's service life.

- (5) When the specific gravity of electrolyte become between 1.27 and 1.29 charge has completed.
- (6) When exchanging an old battery into new one, use battery of equal specification shown in **table 1**.

Table 1

Tractor model	Battery TYPE	Volts (v)	Capacity at 5H.R (A.H)
L35	75D26R-MF	12	52

Tractor model	Reserve Capacity (min)	Cold Cranking Amps	Normal Charging Rate (A)
L35	123	490	5.2

◆ Direction for Storage

- (1) When storing the tractor for long periods of time, remove the battery from tractor, adjust the electrolyte to the proper level and store in a dry place out of direct sunlight.
- (2) The battery self-discharges while it is stored. Recharge it once every three months in hot seasons and once every six months in cold seasons.

EVERY 100 HOURS

■ Changing Engine Oil



CAUTION

To avoid personal injury:

- Be sure to stop the engine before changing the oil.
- Allow engine to cool down sufficiently, oil can be hot and can burn.

- (1) To drain the used oil, remove the drain plug at the bottom of the engine and drain the oil completely into the oil pan.
All the used oil can be drained out easily when the engine is still warm.
- (2) After draining reinstall the drain plug.
- (3) Fill with the new oil up to the upper notch on the dipstick.
(See "LUBRICANTS" in Maintenance Section)

Oil capacity with filter	4.8 ℓ (5.1 U.S.qts.)
--------------------------	----------------------

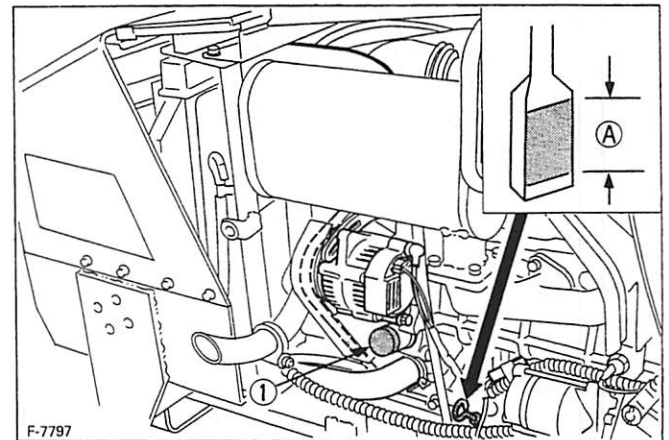

① Oil inlet A Oil level is acceptable within this range

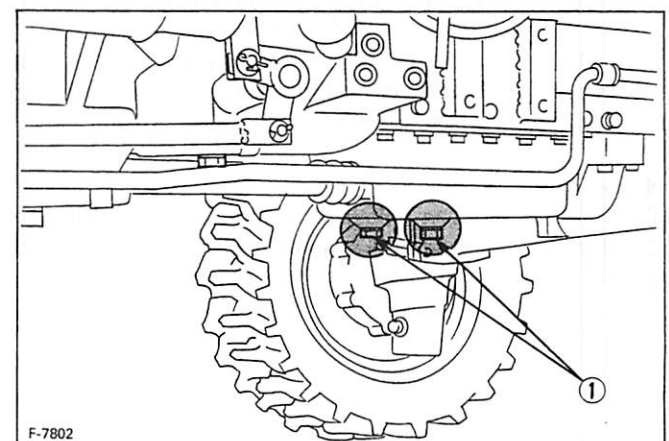

① Drain plug

■ Cleaning Air Cleaner Element

- (1) Remove the element.
- (2) Clean the element:
 - 1) When dry dust adheres to the element, blow compressed air from the inside turning the element. Pressure of compressed air must be under 686kPa (7kgf/cm², 99 psi).
 - 2) When carbon or oil adheres to the element, soak the element in detergent for 15 minutes then wash it several times in water, rinse with clean water and dry it naturally. After element is fully dried, inspect inside of the element with a light and check if it is damaged or not. (referring to the instructions on the label attached to the element.)
- (3) Replace air cleaner element if:

Once yearly or after every sixth cleaning, whichever comes first.

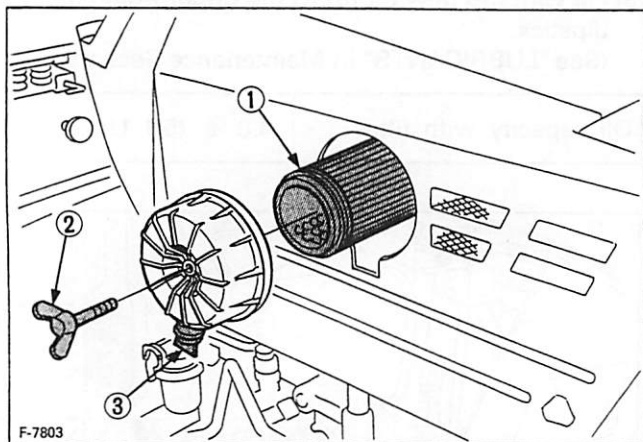

- ① Element
- ② Wing bolt
- ③ Evacuator valve

IMPORTANT:

- The air cleaner uses a dry element, never apply oil.
- Do not run the engine with filter element removed.
- Make sure the wing nut or bolt with rubber dust seal for the element is tight enough. If it is loose, dust and dirt may be sucked in, wearing down the cylinder and piston rings earlier and thereby resulting in poor power output.

◆ Evacuator Valve

Open the evacuator valve once a week under ordinary conditions - or daily when used in a dusty place - to get rid of large particles of dust and dirt.

■ Cleaning Fuel Filter

This job should not be done in the field, but in a clean place.

- (1) Close the fuel filter cock.
- (2) Unscrew the screw ring and remove the filter bowl, and rinse the inside with kerosene.
- (3) Take out the element and dip it in the kerosene to rinse.
- (4) After cleaning, reassemble the fuel filter, keeping out dust and dirt.
- (5) Bleed the fuel system.

(See "Bleeding Fuel System" in as required maintenance)

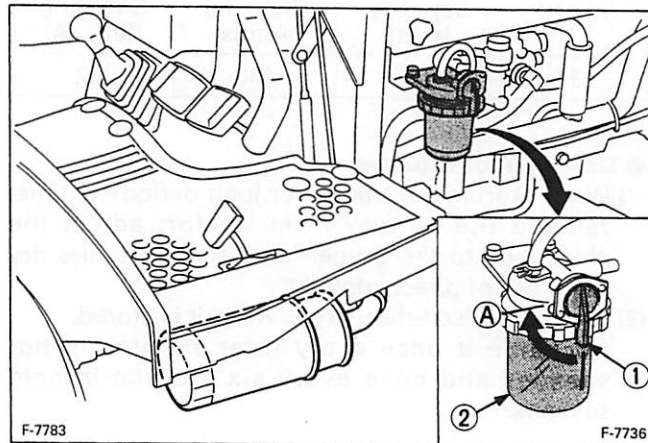

- ① Fuel cock
- ② Fuel filter bowl
- A "CLOSE"

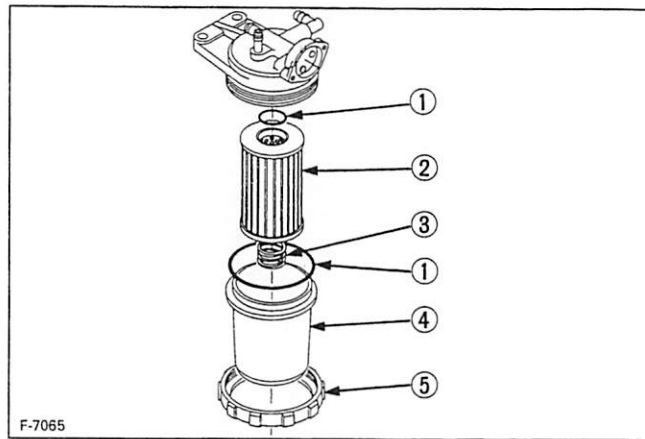

- ① O ring
- ② Filter element
- ③ Spring
- ④ Filter bowl
- ⑤ Screw ring

IMPORTANT:

- If dust and dirt enters the fuel system, the fuel pump and injection nozzles are subject to premature wear. To prevent this, be sure to clean the fuel filter bowl periodically.

■ Adjusting Fan Belt Tension



CAUTION

To avoid personal injury:

- Be sure to stop the engine before checking belt tension.

Proper fan belt tension	A deflection of between 7 to 9 mm (0.28 to 0.34 in.) when the belt is pressed in the middle of the span.
-------------------------	--

- (1) Stop the engine and remove the key.
- (2) Apply moderate thumb pressure to belt between pulleys.
- (3) If tension is incorrect, loosen the alternator mounting bolts and, using a lever placed between the alternator and the engine block, pull the alternator out until the deflection of the belt falls within acceptable limits.
- (4) Replace fan belt if it is damaged.

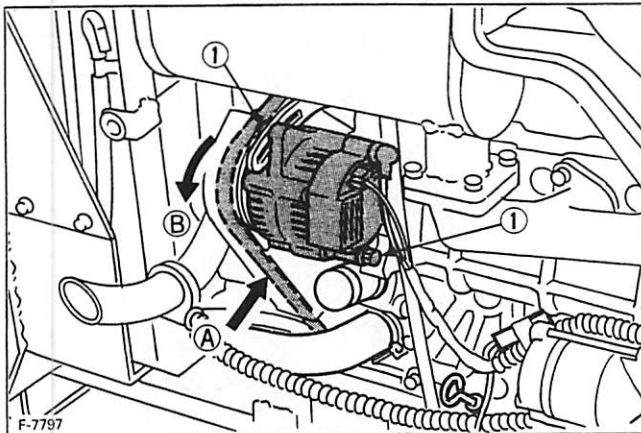

- ① Bolt
- Ⓐ Check the belt tension
- Ⓑ To tighten

NOTE:

- L35 has a front mount hydraulic pump. When replacing the fan belt, remove spacer and two bolts. And then, the fan belt can be moved past between the drive shaft and the coupling.

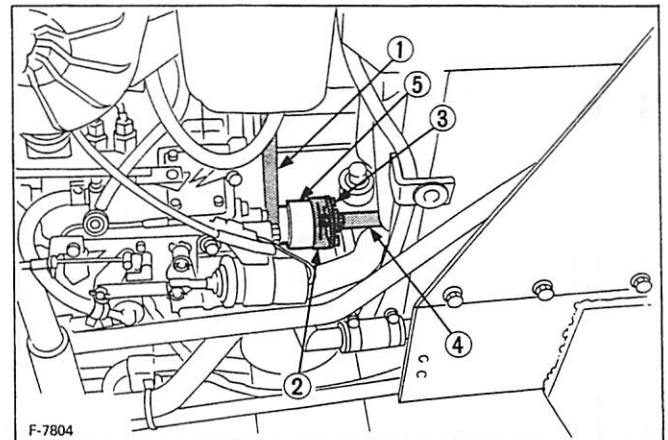

- ① Fan belt
- ② Spacer
- ③ Bolt
- ④ Drive shaft (Hydraulic pump)
- ⑤ Coupling

■ Adjusting Clutch Pedal

Proper clutch pedal free travel	20 to 30 mm (0.8 to 1.2 in.) on the pedal
---------------------------------	---

- (1) Stop the engine and remove the key.
- (2) Slightly depress the clutch pedal and measure free travel at top of pedal stroke.
- (3) If adjustment is needed, loosen the lock nut, remove the clevis pin and adjust the rod length within acceptable limits.
- (4) Retighten the lock nut and split the cotter pin.

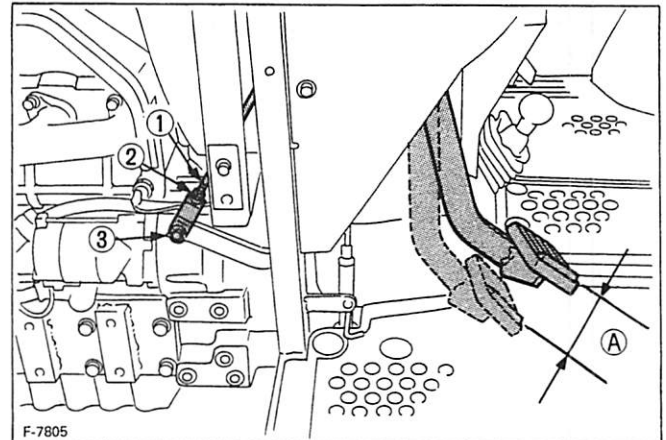

- ① Clutch rod
- ② Nut
- ③ Clevis pin
- Ⓐ Free travel

■ Adjusting Brake Pedal



CAUTION

To avoid personal injury:

- Stop the engine and chock the wheels before checking brake pedal.

Proper brake pedal free travel	15 to 20 mm (0.6 to 0.8 in.) on the pedal.
	Keep the free travel in the right and left brake pedals equal.

- (1) Release the parking brake.
- (2) Slightly depress the brake pedals and measure free travel at top of pedal stroke.
- (3) If adjustment is needed, loosen the lock nut and turn the turnbuckle to adjust the rod length with in acceptable limits.
- (4) Retighten the lock nut.

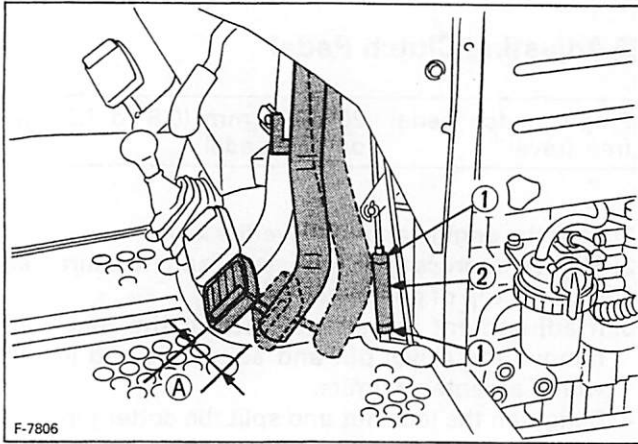

① Lock nut

Ⓐ Free travel

② Turnbuckle

EVERY 200 HOURS

■ Replacing Engine Oil Filter



CAUTION

To avoid personal injury:

- Be sure to stop the engine before changing the oil filter cartridge.
- Allow engine to cool down sufficiently, oil can be hot and can burn.

- (1) Remove the oil filter.
- (2) Put a film of clean engine oil on rubber seal of new filter
- (3) Tighten the filter quickly until it contacts the mounting surface.
Tighten filter by hand an additional 1/2 turn only.
- (4) After the new filter has been replaced, the engine oil normally decreases a little. Make sure that the engine oil does not leak through the seal and be sure to check the oil level on the dipstick. Then, replenish the engine oil up to the prescribed level.

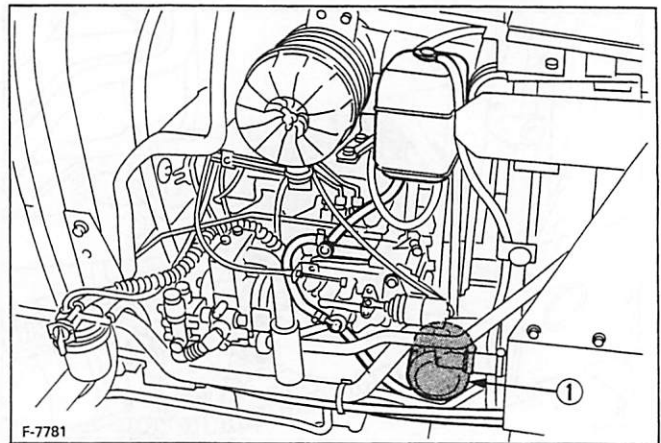

① Engine oil filter

IMPORTANT:

- To prevent serious damage to the engine, use only a genuine KUBOTA filter.

■ Replacing Hydraulic Oil Filter



CAUTION

To avoid personal injury:

- Allow engine to cool down sufficiently, oil can be hot and can burn.

- (1) Remove the oil filter.
- (2) Put a film of clean transmission oil on rubber seal of new filter.
- (3) Tighten the filter quickly until it contacts the mounting surface.
Tighten filter by hand an additional 1/2 turn only.
- (4) After the new filter has been replaced, the transmission fluid level will decrease a little. Make sure that the transmission fluid does not leak through the seal, and check the fluid level.
Top up if necessary.

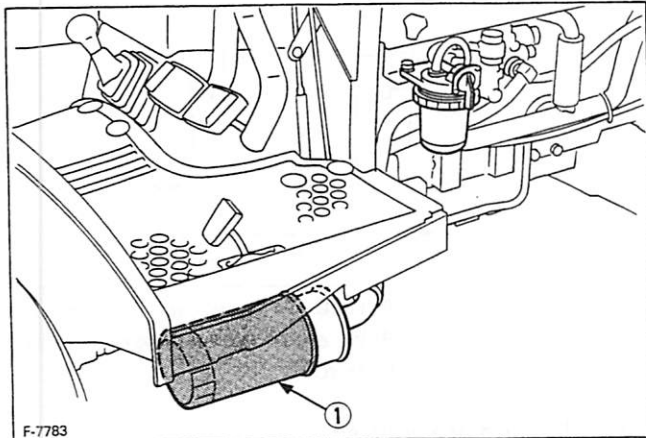

① Hydraulic oil filter

IMPORTANT:

- To prevent serious damage to the hydraulic system, use only a genuine KUBOTA filter.

■ Checking Radiator Hose and Clamp

Check to see if radiator hoses are properly fixed every 200 hours of operation or six months, whichever comes first.

- (1) If hose clamps are loose or water leaks, tighten bands securely.
- (2) Replace hoses and tighten hose clamps securely, if radiator hoses are swollen, hardened or cracked. Replace hoses and hose clamps every 2 years or earlier if checked and found that hoses are swollen, hardened or cracked.

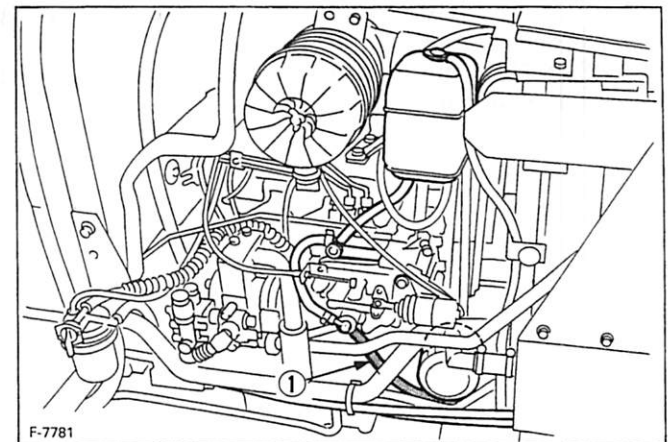
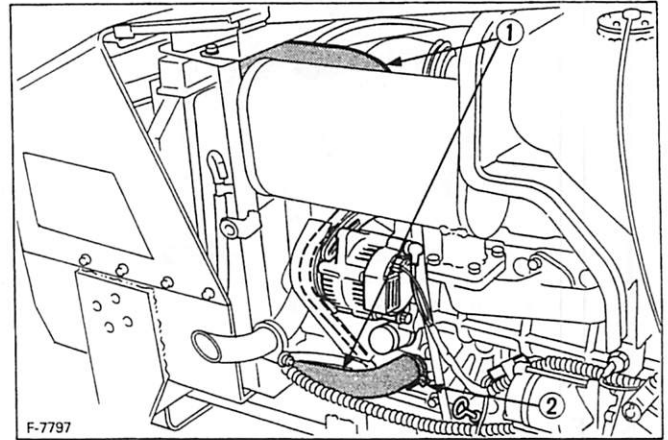

① Radiator hoses

② Clamp bands

◆ Precaution at Overheating

Take the following actions in the event the coolant temperature be nearly or more than the boiling point, what is called "Overheating"

- (1) Stop the machine operation in a safe place and keep the engine unloaded idling.
- (2) Don't stop the engine suddenly, but stop it after about 5 minutes of unloaded idling.
- (3) Keep yourself well away from the machine for further 10 minutes or while the steam blown out.
- (4) Checking that there gets no danger such as burn, get rid of the causes of overheating according to the manual, see "Troubleshooting" section, And then, start again the engine.

■ Checking Power Steering Line
■ Checking Fuel Line

- (1) Check to see that all lines and hose clamps are tight and not damaged.
- (2) If hoses and clamps are found worn or damaged, replace or repair them at once.

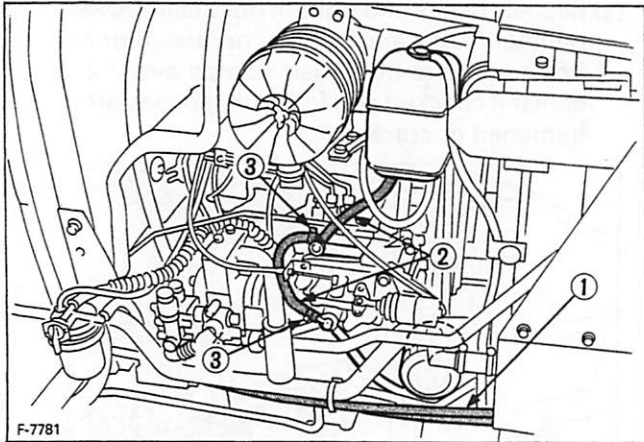

- ① Power steering pressure hoses
- ② Fuel lines
- ③ Clamp bands

NOTE:

- If the fuel line is removed, be sure to properly bleed the fuel system. (See "Bleeding Fuel System" in as required maintenance)

■ Adjusting Toe-in

- (1) Park tractor on a flat place.
- (2) Turn steering wheel so front wheels are in the straight ahead position.
- (3) Lower the implement, lock the park brake and stop the engine.
- (4) Measure distance between tire beads at front of tire, hub height.
- (5) Measure distance between tire beads at rear of tire, hub height.
- (6) Front distance should be 2 to 8 mm (0.08 to 0.3 in.) less than rear distance. If not, adjust tie rod length.

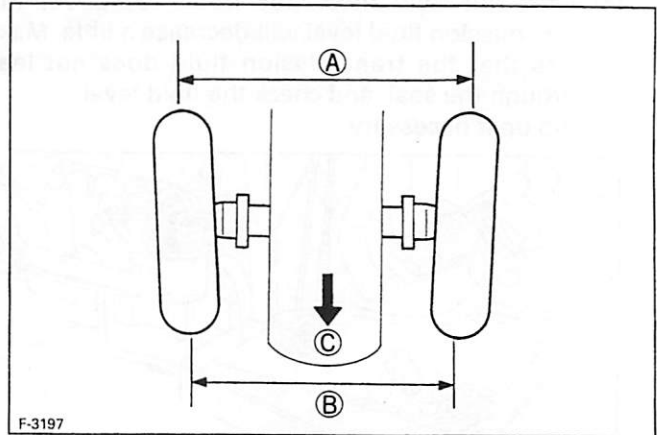

- A Wheel - to - wheel distance at rear
- B Wheel - to - wheel distance at front
- C "FRONT"

◆ Adjusting procedure

- (1) Loosen the lock nut and turn the turnbuckle to adjust the rod length until the proper toe-in measurement is obtained.
- (2) Retighten the lock nut.

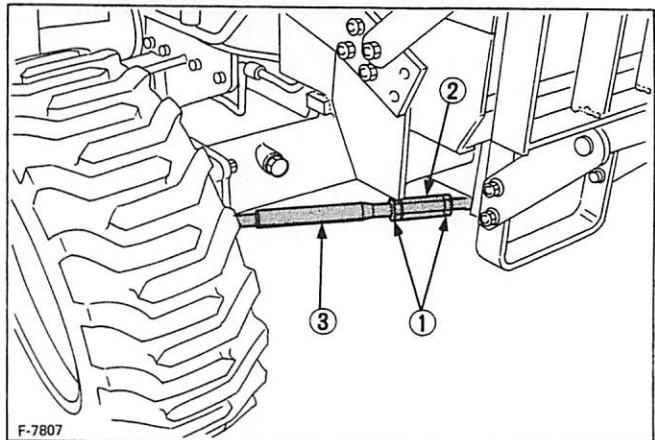

- ① Lock nuts
- ② Turn buckle
- ③ Tie rod

EVERY 400 HOURS

■ Changing Transmission Fluid



CAUTION

To avoid personal injury:

- Allow engine to cool down sufficiently, oil can be hot and can burn.

- (1) To drain the used oil, remove the drain plug at the bottom of the transmission case and drain the oil completely into the oil pan.
- (2) After draining reinstall the drain plug.
- (3) Fill with the new KUBOTA SUPER UDT fluid up to the upper notch on the dipstick.
(See "LUBRICANTS" in Maintenance Section)
- (4) After running the engine for a few minutes, stop it and check the oil level again; add oil to prescribed level.

Oil capacity	39 ℓ (41.2 U.S.qts.)
--------------	----------------------

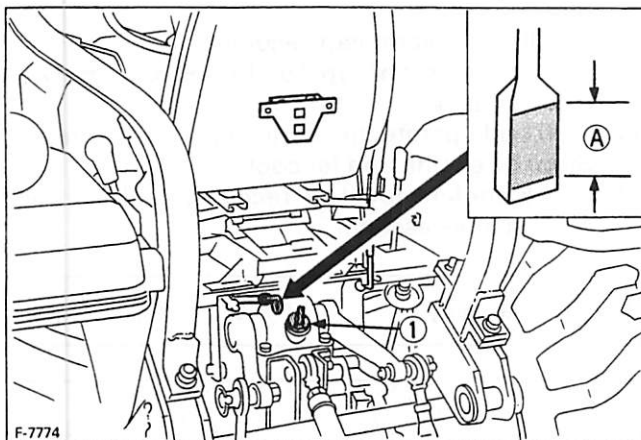

① Oil inlet A Oil level is acceptable within this range

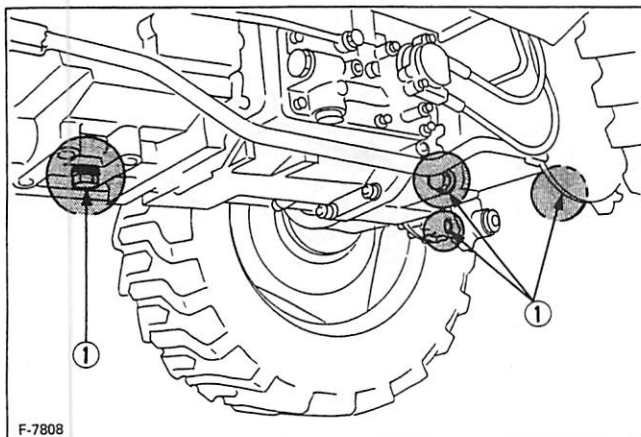

① Drain plugs

IMPORTANT:

- Do not operate the tractor immediately after changing the transmission fluid.
Run the engine at medium speed for a few minutes to prevent damage to the transmission.

■ Replacing Fuel Filter Element

(See "Cleaning fuel filter" in every 100 hours maintenance.)

■ Changing Front Axle Case Oil

- (1) To drain the used oil, remove the right and left drain plugs and filling plugs at the front axle case and drain the oil completely into the oil pan.
- (2) After draining reinstall the drain plugs.
- (3) Remove the oil level check plug.
- (4) Fill with the new oil up to the check plug port.
(See "LUBRICANTS" in Maintenance Section)
- (5) After filling reinstall the filling plug and check plug.

Oil capacity	5.5 ℓ (5.8 U.S.qts.)
--------------	----------------------

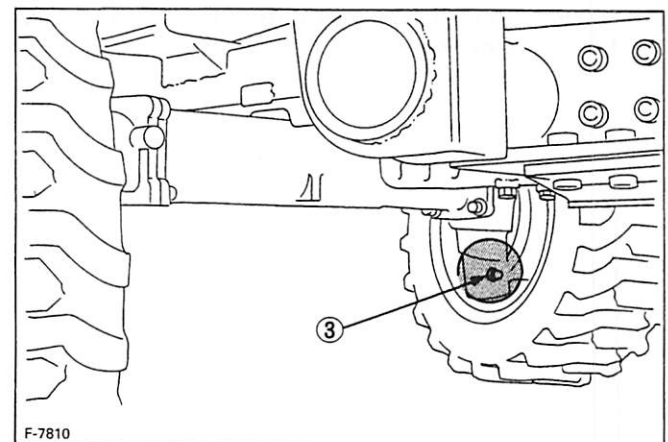
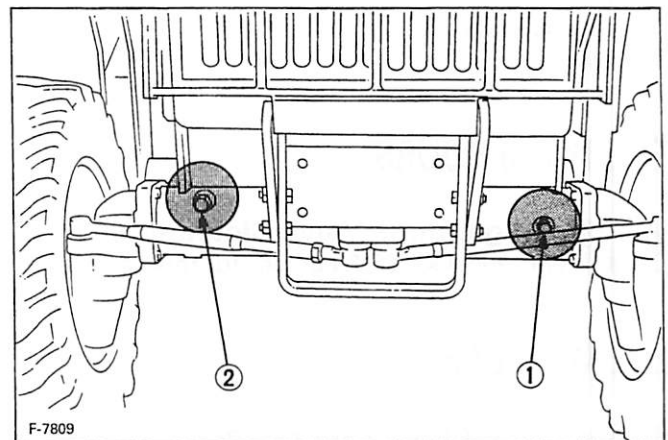

① Check plug
② Filling plug
③ Drain plug

■ Adjusting Front Axle Pivot

If the front axle pivot pin adjustment is not correct, front wheel vibration can occur causing vibration in the steering wheel.

◆ Adjusting procedure

Loosen the lock nut, tighten the adjusting screw all the way, and then loosen the screw by 1/6 turn. Retighten the lock nut.

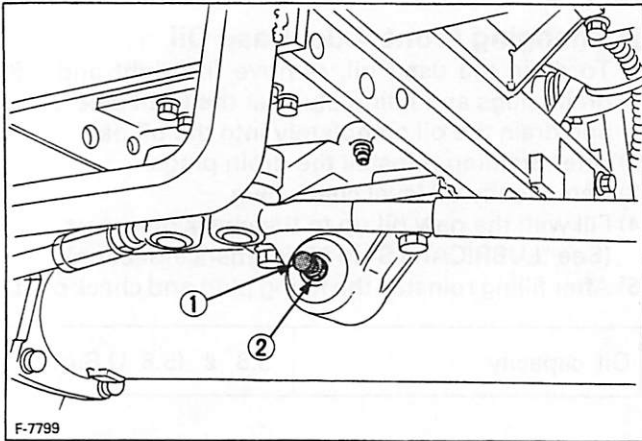

- ① Adjusting screw
- ② Lock nut

EVERY 800 HOURS

■ Adjusting Engine Valve Clearance

Consult your local KUBOTA dealer for this service.

EVERY 1 YEAR

■ Replacing Air Cleaner Element

(See "Cleaning Air Cleaner Primary Element" in every 100 hours maintenance.)

EVERY 2 YEARS

■ Flush Cooling System and Changing Coolant



CAUTION

To avoid personal injury:

- Do not remove the radiator cap when the engine is hot. Then loosen cap slightly to the stop to relieve any excess pressure before removing cap completely.

- (1) Stop the engine and let cool down.
- (2) To drain the coolant, open the radiator drain plug. And remove radiator cap. The radiator cap must be removed to completely drain the coolant.
- (3) After all coolant is drained, close the drain plug.
- (4) Fill with clean water and cooling system cleaner.
- (5) Follow directions of the cleaner instruction.
- (6) After flushing, fill with clean water and anti-freeze until the coolant level is just below the port.
Install the radiator cap securely.
- (7) Fill with coolant up to the "FULL" mark of recovery tank.
- (8) Start and operate the engine for few minutes.
- (9) Stop the engine and let cool.
- (10) Check coolant level of recovery tank and add coolant if necessary.

Coolant capacity	7.0 ℓ (7.4 U.S.qts.)
------------------	----------------------

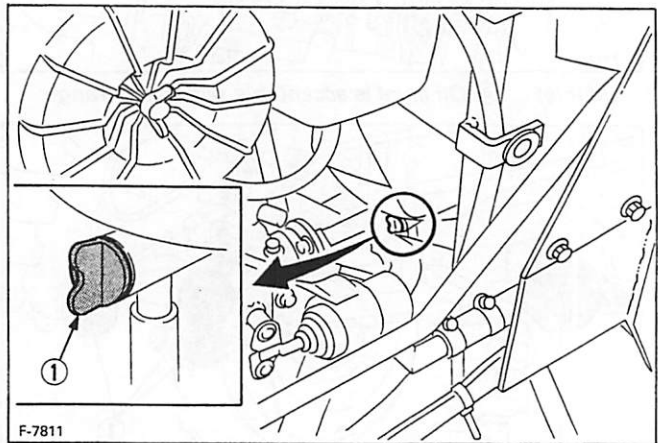

- ① Drain plug

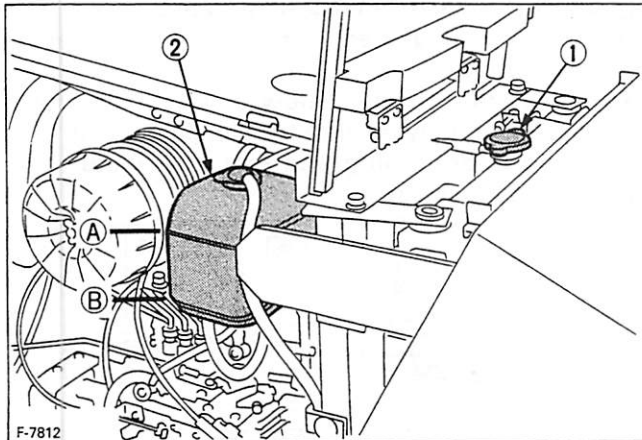

① Radiator cap A "FULL"
 ② Recovery tank B "LOW"

IMPORTANT:

- Do not start engine without coolant.
- Use clean, fresh water and anti-freeze to fill the radiator and recovery tank.
- When the anti-freeze is mixed with water, the anti-freeze mixing ratio must be less than 50%.
- Securely tighten radiator cap. If the cap is loose or improperly fitted, water may leak out and the engine could overheat.

■ Anti-Freeze

If it freezes, cooling water can damage the cylinders and radiator. It is necessary, if the ambient temperature falls below 0°C (32°F), to remove cooling water after operating or to add anti-freeze to it.

- (1) There are two types of anti-freeze available; use the permanent type (PT) for this engine.
- (2) Before adding anti-freeze for the first time, clean the radiator interior by pouring fresh water and draining it a few times.
- (3) The procedure for mixing of water and anti-freeze differs according to the make of the anti-freeze and the ambient temperature, basically it should be referred to SAE J1034 standard, more specifically also to SAE J814c.
- (4) Mix the anti-freeze with water, and then fill in to the radiator.

Vol % Anti-freeze	Freezing Point		Boiling Point*	
	°F	°C	°F	°C
40	-12	-24	222	106
50	-34	-37	226	108

* At 760mmHg pressure (atmospheric). A higher boiling point is obtained by using a radiator pressure cap which permits the development of pressure within the cooling system.

NOTE:

- The above data represents industry standards that necessitate a minimum glycol content in the concentrated anti-freeze.
- When the cooling water level drops due to evaporation, add water only. In case of leakage, add anti-freeze and water in the specified mixing ratio.
- Anti-freeze absorbs moisture. Keep unused anti-freeze in a tightly sealed container.
- Do not use radiator cleaning agents when anti-freeze has been added to the cooling water. (Anti-freeze contains an anti-corrosive agent, which will react with the radiator cleaning agent forming sludge which will affect the engine parts.)

■ Replacing Radiator Hose (Water pipes)

Replace the hoses and clamps.
 (See "Checking Radiator Hose and Clamp" in every 200 hours maintenance.)

■ Replacing Power Steering Hose

Replace the hoses and clamps, if necessary.
 (See "Checking Power Steering line" in every 200 hours maintenance.)

■ Replacing Fuel Hose

Replace the hoses and clamps, if necessary.
 (See "Checking Fuel line" in every 200 hours maintenance.)

SERVICE AS REQUIRED

■ Bleeding Fuel System

Air must be removed:

- (1) When the fuel filter or lines are removed.
- (2) When tank is completely empty.
- (3) After the tractor has not been used for a long period of time.

◆ Bleeding procedure is as follows:

- (1) Fill the fuel tank with fuel, and open the fuel cock.

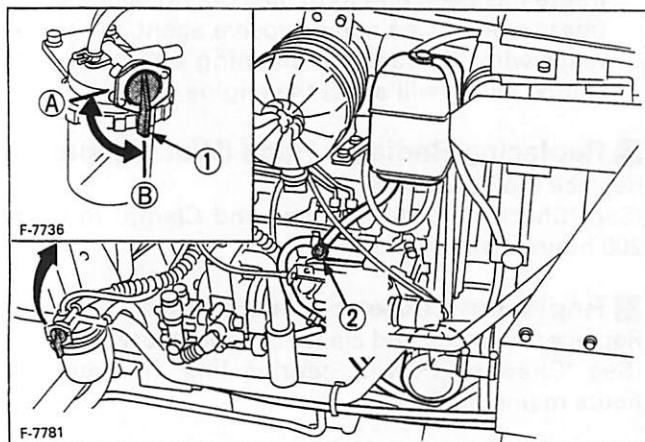

- | | |
|-----------------|-----------|
| ① Fuel cock | Ⓐ "CLOSE" |
| ② Air vent cock | Ⓑ "OPEN" |

- (2) Open the air vent cock on the fuel injection pump.
- (3) Start the engine and run for about 30 seconds, and then stop the engine.
- (4) Close the air vent cock.

IMPORTANT:

- Always close the air vent cock except for bleeding fuel lines. Otherwise, engine runs irregularly or stalls frequently.

■ Draining Clutch Housing Water

The tractor is equipped with drain plug under the clutch housing.

After operating in rain, snow or tractor has been washed, water may get into the clutch housing. Remove the drain plug and drain the water, then install the plug again.

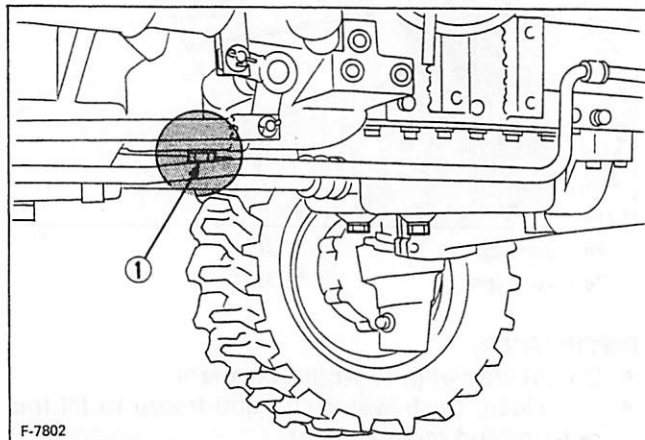

- ① Water drain plug

■ Replacing Fuse

The tractor electrical system is protected from potential damage by fuses.

A blown fuse indicates that there is an overload or short somewhere in the electrical system.

If any of the fuses should blow, replace with a new one of the same capacity,

IMPORTANT:

- Before replacing a blown fuse, determine why the fuse blew and make any necessary repairs. Failure to follow this procedure may result in serious damage to the tractor electrical system. Refer to the troubleshooting section of this manual or your local KUBOTA dealer for specific information dealing with electrical problems.
- If any of them should blow, replace with a new one of the same capacity.

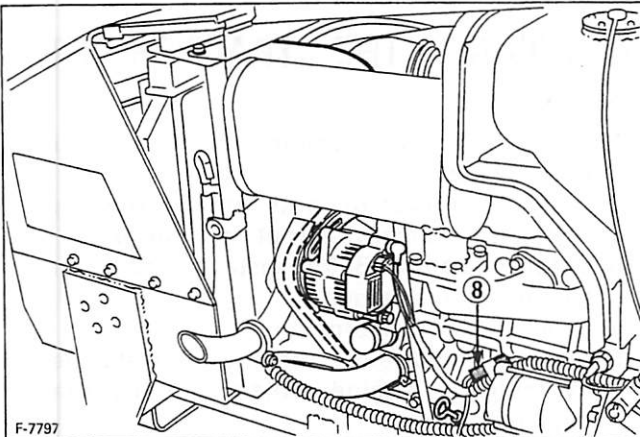
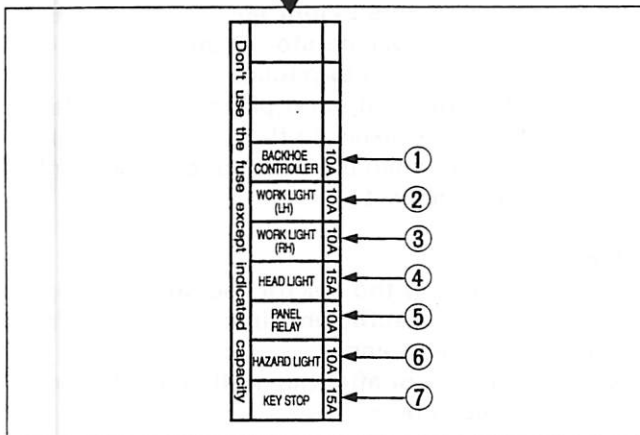
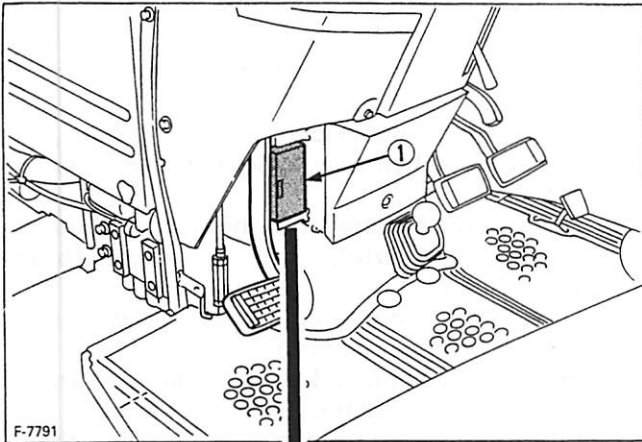

◆ Protected circuit

Fuse No.	Capacity (A)	Protected circuit
①	10	Backhoe controller
②	10	Work light (LH)
③	10	Work light (RH)
④	15	Head light
⑤	10	Panel, Relay
⑥	10	Hazard light
⑦	15	Key stop
⑧	Slow blow fuse	Check circuit against wrong battery connection.

■ Replacing Light Bulb

- (1) Head lights and rear combination lights
Take the bulb out of the light body and replace with a new one.
- (2) Other lights
Detach the lens and replace the bulb.

Light	Capacity
Headlights	25W/25W
Tail light, Parking light (rear)	8W
Hazard light	27W
Instrument panel light	3.4W

STORAGE



CAUTION

To avoid personal injury:

- Do not clean the machine with engine running.
- To avoid the danger of exhaust fume poisoning, do not operate the engine in a closed building without proper ventilation.
- When storing, remove the key from the key switch to avoid unauthorized persons from operating the tractor and getting injured.

TRACTOR STORAGE

If you intend to store your tractor for an extended period of time, follow the procedures outlined below. These procedures will insure that the tractor is ready to operate with minimum preparation when it is removed from storage,

- (1) Check the bolts and nuts for looseness, and tighten if necessary.
- (2) Apply grease to tractor areas where bare metal will rust also to pivot areas.
- (3) Detach the weights from the tractor body.
- (4) Inflate the tires to a pressure a little higher than usual.
- (5) Change the engine oil and run the engine to circulate oil throughout the engine block and internal moving parts for about five minutes.
- (6) Pull the engine stop knob all the way out.
- (7) Keep the clutch disengaged. If the clutch is left engaged for a long period of time, the clutch plate may rust, making clutch disengagement impossible at the next operation.

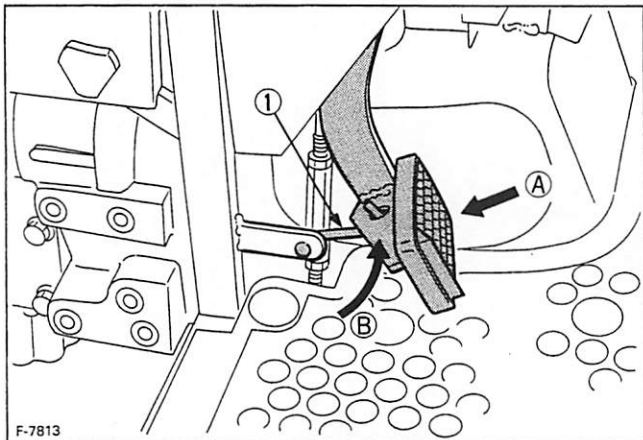

① Lock plate

Ⓐ "DEPRESS"

Ⓑ "HOOK TO LOCK"

- (8) With all implements lowered to the ground, coat any exposed hydraulic cylinder piston rods with grease.
- (9) Remove the battery from the tractor. Store the battery following the battery storage procedures.
(See "Battery condition" in every 50 hours in periodic service section.)
- (10) Keep the tractor in a dry place where the tractor is sheltered from rain. Cover the tractor.
- (11) Store the tractor indoors in a dry area that is protected from sunlight and excessive heat. If the tractor must be stored outdoors, cover it with a waterproof tarpaulin.
Jack the tractor up and place blocks under the front and rear axles so that all four tires are off the ground. Keep the tires out of direct sunlight and extreme heat.

IMPORTANT:

- When washing the tractor, be sure to stop the engine. Allow sufficient time for the engine to cool before washing.
- Cover the tractor after the muffler and the engine have cooled down.

REMOVING THE TRACTOR FROM STORAGE

- (1) Check the tire air pressure and inflate the tires if they are low.
- (2) Jack the tractor up and remove the support blocks from under the front and rear axles.
- (3) Install the battery. Before installing the battery, be sure it is fully charged.
- (4) Check the fan belt tension.
- (5) Check all fluid levels (engine oil, transmission/hydraulic oil, engine coolant and any attached implements).
- (6) Start the engine. Observe all gauges. If all gauges are functioning properly and reading normal, move the tractor outside. Once outside, park the tractor and let the engine idle for at least five minutes. Shut the engine off and walk around tractor and make a visual inspection looking for evidence of oil or water leaks.
- (7) With the engine fully warmed up, release the parking brake and test the brakes for proper adjustment as you move forward. Adjust the brakes as necessary.

TROUBLESHOOTING

ENGINE TROUBLESHOOTING

If something is wrong with the engine, refer to the table below for the cause and its corrective measure.

Trouble		Cause	Countermeasure
Engine is difficult to start or won't start.		<ul style="list-style-type: none"> No fuel flow. 	<ul style="list-style-type: none"> Check the fuel tank and the fuel filter. Replace filter if necessary.
		<ul style="list-style-type: none"> Air or water is in the fuel system. 	<ul style="list-style-type: none"> Check to see if the fuel line coupler bolt and nut are tight. Bleed the fuel system (See "Bleeding Fuel System" in as required maintenance)
		<ul style="list-style-type: none"> In winter, oil viscosity increases, and engine revolution is slow. 	<ul style="list-style-type: none"> Use oils of different viscosities, depending on ambient temperatures. Use engine block heater. (Option)
		<ul style="list-style-type: none"> Battery becomes weak and the engine does not turn over quick enough. 	<ul style="list-style-type: none"> Clean battery cables and terminals. Charge the battery. In cold weather, always remove the battery from the engine, charge and store it indoors. Install it on the tractor only when the tractor is going to be used.
Insufficient engine power.		<ul style="list-style-type: none"> Insufficient of dirty fuel. The air cleaner is clogged. 	<ul style="list-style-type: none"> Check the fuel system. Clean the element.
Engine stops suddenly.		<ul style="list-style-type: none"> Insufficient fuel. 	<ul style="list-style-type: none"> Refuel. Bleed the fuel system if necessary.
Exhaust fumes are colored.	Black	<ul style="list-style-type: none"> Fuel quality is poor. Too much oil. 	<ul style="list-style-type: none"> Change the fuel and fuel filter. Check the proper amount of oil.
	Blue white	<ul style="list-style-type: none"> The inside of exhaust muffler is dumped with fuel. Injection nozzle trouble. Poor quality fuel. 	<ul style="list-style-type: none"> Heat the muffler by applying load to the engine. Check the injection nozzle. Change the fuel and fuel filter.
Engine overheats.		<ul style="list-style-type: none"> Engine overloaded. 	<ul style="list-style-type: none"> Shift to lower gear or reduce load.
		<ul style="list-style-type: none"> Low coolant level. 	<ul style="list-style-type: none"> Fill cooling system to the correct level; check radiator and hoses for loose connections or leaks.
		<ul style="list-style-type: none"> Loose or defective fan belt. 	<ul style="list-style-type: none"> Adjust or replace fan belt.
		<ul style="list-style-type: none"> Dirty radiator core or grille screens. 	<ul style="list-style-type: none"> Remove all trash.
		<ul style="list-style-type: none"> Coolant flow route corroded. 	<ul style="list-style-type: none"> Flush cooling system.

If you have any questions, contact your local KUBOTA dealer.

OPTIONS

Consult your local KUBOTA dealer for further detail.

- **Engine precleaner**
For extremely dusty conditions.
- **Engine Block Heater**
For extremely cold weather starting.
- **Vertical Muffler**
- **Spark Arrestor**
- **SMV (Slow Moving Vehicle) Emblem:**
To identify slow moving vehicle.
- **Work Light (Front, Rear)**
High visibility for night work.
- **Rear Work Light**
High visibility for night work.
- **Back Up Alarm**
- **Fixed hitch**
- **Top & tilt kit**
- **Front guard**
- **Double Element Air Cleaner**

KUBOTA Corporation is . . .

Since its inception in 1890, KUBOTA Corporation has grown to rank as one of the major firms in Japan.

To achieve this status, the company has through the years diversified the range of its products and services to a remarkable extent, until today, 19 plants and 16,000 employees produce over 1,000 different items, large and small.

All these products and all the services which accompany them, however, are unified by one central commitment. KUBOTA makes products which, taken on a national scale, are basic necessities. Products which are indispensable, products intended to help individuals and nations fulfill the potential inherent in their environment. For KUBOTA is the Basic Necessities Giant.

This potential includes water supply, food from the soil and from the sea, industrial development, architecture and construction, transportation.

Thousands of people depend on KUBOTA's know-how, technology, experience and customer service. You too can depend on KUBOTA.

Kubota®

KUBOTA TRACTOR CORPORATION

CORPORATE OFFICE: 3401 DEL AMO BOULEVARD, TORRANCE, CA 90503

WESTERN DIVISION: 1175 S. Guild Ave., Lodi, CA 95240 • (209) 334-9910

CENTRAL DIVISION: 14855 F.A.A. Blvd., Fort Worth, TX 76155 • (817) 871-0900

NORTHERN DIVISION: One Kubota Way, Groveport, OH 43125 • (614) 835-1100

SOUTHEAST DIVISION: 1025 Northbrook Parkway, Suwanee, GA 30024 • (770) 995-8855

Copyright (c) 2002 by Kubota Tractor Corporation - All Rights Reserved

This manual may not be copied in whole or in part without the written consent of Kubota Tractor Corporation



* 3 2 7 5 1 - 1 9 7 1 2 *

REPRINTED IN U.S.A.
June 2002
Code No. 32751-19712

