

OPERATOR'S MANUAL

KUBOTA TRACTOR

MODEL L4600



1AGAPBXAP0010

READ AND SAVE THIS MANUAL

Kubota

ABBREVIATION LIST

Abbreviations	Definitions
2WD	Two Wheel Drive
4WD	Four Wheel Drive
API	American Petroleum Institute
ASABE	American Society of Agricultural and Biological Engineers, USA
ASTM	American Society for Testing and Materials, USA
DIN	Deutsches Institut für Normung, GERMANY
DT	Dual Traction [4WD]
fpm	Feet Per Minute
GST	Glide Shift Transmission
Hi-Lo	High Speed-Low Speed
HST	Hydrostatic Transmission
m/s	Meters Per Second
PTO	Power Take Off
RH/LH	Right-hand and left-hand sides are determined by facing in the direction of forward travel
ROPS	Roll-Over Protective Structures
rpm	Revolutions Per Minute
r/s	Revolutions Per Second
SAE	Society of Automotive Engineers, USA
SMV	Slow Moving Vehicle

California Proposition 65

⚠ WARNING ⚠

The engine exhaust from this product contains chemicals known to the State of California to cause cancer, birth defects or other reproductive harm.

IMPORTANT

The engine in this machine is not equipped by the manufacturer with a standard spark arrester. It is a violation of California Public Resource Code Section 4442 to use or operate this engine on or near any forest-covered, brush-covered land, or grass-covered land unless the exhaust system is equipped with a working spark arrester meeting state laws. Other states or federal areas may have similar laws.

UNIVERSAL SYMBOLS

As a guide to the operation of your tractor, various universal symbols have been utilized on the instruments and controls. The symbols are shown below with an indication of their meaning.

	Safety Alert Symbol		Remote Cylinder-Retract
	Diesel Fuel		Remote Cylinder-Extend
	Fuel-Level		Steering Wheel-Tilt Control
	Engine-Rotational Speed		Hazard Warning Lights
	Hourmeter/Elapsed Operating Hours		Master Lighting Switch
	Engine Coolant-Temperature		Position Lamps
	Diesel Preheat/Glow Plugs(Low Temperature Start Aid)		Headlight-Low Beam
	Diesel Preheat/Glow Plugs(Low Temperature Start Aid)		Headlight-High Beam
	Parking Brake		Audible Warning Device
	Engine Intake/Combustion Air-Filter		Four-Wheel Drive-On
	Battery Charging Condition		Four-Wheel Drive-Off
	Engine Oil-Pressure		Fast
	Turn Signal		Slow
	Engine-Stop		Creep
	Engine-Run		Read Operator's Manual
	Starter Control		Tractor-Forward Movement-Overhead View of Machine
	Power Take-Off Control-Off Position		Tractor-Rearward Movement-Overhead View of Machine
	Power Take-Off Control-On Position		Engine Speed Control
	Differential Lock		
	Position Control-Raised Position		
	Position Control-Lowered Position		
	Draft Control-Shallow Position		
	Draft Control-Deep Position		
	3-Point Lowering Speed Control		

FOREWORD

You are now the proud owner of a KUBOTA Tractor. This tractor is a product of KUBOTA quality engineering and manufacturing. It is made of fine materials and under a rigid quality control system. It will give you long, satisfactory service. To obtain the best use of your tractor, please read this manual carefully. It will help you become familiar with the operation of the tractor and contains many helpful hints about tractor maintenance. It is KUBOTA's policy to utilize as quickly as possible every advance in our research. The immediate use of new techniques in the manufacture of products may cause some small parts of this manual to be outdated. KUBOTA distributors and dealers will have the most up-to-date information. Please do not hesitate to consult with them.



SAFETY FIRST

This symbol, the industry's "Safety Alert Symbol", is used throughout this manual and on labels on the machine itself to warn of the possibility of personal injury. Read these instructions carefully. It is essential that you read the instructions and safety regulations before you attempt to assemble or use this unit.



DANGER : Indicates an imminently hazardous situation which, if not avoided, will result in death or serious injury.



WARNING : Indicates a potentially hazardous situation which, if not avoided, could result in death or serious injury.



CAUTION : Indicates a potentially hazardous situation which, if not avoided, may result in minor or moderate injury.

IMPORTANT : Indicates that equipment or property damage could result if instructions are not followed.

NOTE : Gives helpful information.

CONTENTS

▲ SAFE OPERATION	1
SERVICING OF TRACTOR.....	1
SPECIFICATIONS.....	2
SPECIFICATION TABLE	2
TRAVELING SPEEDS	4
IMPLEMENT LIMITATIONS	5
INSTRUMENT PANEL AND CONTROLS.....	7
PRE-OPERATION CHECK	10
DAILY CHECK	10
OPERATING THE ENGINE.....	11
STARTING THE ENGINE	11
COLD WEATHER STARTING	14
Block Heater (if equipped)	14
STOPPING THE ENGINE.....	15
WARMING UP	15
Warm-Up Transmission Oil in the Low Temperature Range	15
JUMP STARTING	15
OPERATING THE TRACTOR	17
OPERATING NEW TRACTOR	17
Do not Operate the Tractor at Full Speed for the First 50 Hours.....	17
Changing Lubricating Oil for New Tractors.....	17
OPERATING FOLDABLE ROPS (if equipped)	17
To Fold the ROPS	17
To Raise the ROPS to Upright Position.....	18
Adjustment of Foldable ROPS.....	19
STARTING	19
Operator's Seat.....	19
Seat Belt.....	20
Head Light / Turn Signal / Hazard Light Switch.....	20
Tractor Lights.....	21
Brake Pedals (Right and Left).....	21
Clutch Pedal	22
Main Gear Shift Lever & Range Gear Shift Lever.....	23
Synchro-Shuttle Shift Lever	23
Front Wheel Drive Lever.....	24
Hand Throttle Lever	24
Foot Throttle	24
Parking Brake	24
Range Gear Shift Lever (L-M-H).....	25
Front Wheel Drive Lever.....	26
Hand Throttle Lever	26
Parking Brake	26
Speed Control Pedal.....	27

Cruise Control Lever.....	27
STOPPING.....	28
Stopping.....	28
CHECK DURING DRIVING	28
Immediately Stop the Engine if:.....	28
Easy Checker(TM).....	28
Fuel Gauge.....	29
Coolant Temperature Gauge.....	29
Hourmeter/Tachometer.....	29
PARKING.....	30
Parking.....	30
Parking.....	30
OPERATING TECHNIQUES	31
Differential Lock.....	31
Operating the Tractor on a Road.....	31
Operating on Slopes and Rough Terrain.....	32
Directions for Use of Power Steering.....	32
Electrical Outlet.....	32
PTO.....	33
PTO OPERATION.....	33
PTO Clutch Control Switch.....	33
Stationary PTO.....	34
PTO Shaft Cover and Shaft Cap.....	34
THREE-POINT HITCH & DRAWBAR.....	35
3-POINT HITCH.....	36
Selecting the top link mounting holes.....	36
Drawbar.....	36
Lifting Rod (Right).....	36
Top Link.....	36
Telescopic Stabilizers.....	37
DRAWBAR.....	37
Adjusting Drawbar Length.....	37
Swing Drawbar(if equipped).....	38
HYDRAULIC UNIT.....	39
3-POINT HITCH CONTROL SYSTEM.....	39
Position Control.....	39
Draft Control (if equipped).....	39
Mixed Control.....	40
Float Control.....	40
3-point Hitch Lowering Speed.....	40
AUXILIARY HYDRAULICS	41
Hydraulic Block Type Outlet.....	41
REMOTE HYDRAULIC CONTROL SYSTEM (if equipped).....	41
Remote Control Valve.....	41
Remote Control Valve Lever.....	41
Remote Control Valve Coupler Connecting and Disconnecting.....	42
Hydraulic Control Unit Use Reference Chart.....	43
TIRES, WHEELS AND BALLAST.....	44
TIRES.....	44

Inflation Pressure.....	44
Dual Tires	44
WHEEL ADJUSTMENT	44
Front Wheels (with two wheel drive).....	44
Front Wheels (with four wheel drive).....	46
Rear Wheels.....	47
BALLAST	48
Front Ballast.....	48
Rear Ballast	48
Liquid Ballast in Rear Tires.....	49
MAINTENANCE.....	50
SERVICE INTERVALS	50
LUBRICANTS, FUEL AND COOLANT	52
PERIODIC SERVICE.....	55
HOW TO OPEN THE HOOD	55
Hood.....	55
Side Cover.....	55
DAILY CHECK.....	56
Walk Around Inspection.....	56
Checking and Refueling.....	56
Checking Engine Oil Level.....	57
Checking Transmission Fluid Level.....	57
Checking Coolant Level.....	58
Cleaning Evacuator Valve	58
Cleaning Grill, Radiator Screen and Oil Cooler	58
Checking Brake Pedals and Clutch Pedal.....	59
Checking Gauges, Meter and Easy Checker(TM).....	59
Checking Head Light, Turn Signal / Hazard Light etc.....	59
Checking Seat Belt and ROPS.....	59
Checking and Cleaning of Electrical Wiring and Battery Cables	59
Checking Movable Parts.....	59
EVERY 50 HOURS.....	60
Lubricating Grease Fittings.....	60
Checking Engine Start System.....	61
Checking Wheel Bolt Torque.....	62
Checking Tie-rod Dust Cover	62
EVERY 100 HOURS.....	63
Cleaning Air Cleaner Primary Element.....	63
Cleaning Fuel Filter.....	63
Adjusting Fan Belt Tension.....	64
Checking Fuel Line.....	64
Adjusting Clutch Pedal.....	64
Adjusting Brake Pedal	65
Checking Battery Condition	65
EVERY 200 HOURS.....	66
Replacing Engine Oil Filter	66
Changing Engine Oil.....	67
Replacing Transmission Oil Filter [HST Type].....	67
Checking Radiator Hose and Clamp	68
Checking Oil Cooler Line.....	68

CONTENTS

Checking Intake Air Line.....	69
Checking Power Steering Line	69
Adjusting Toe-in.....	69
EVERY 400 HOURS	70
Changing Transmission Fluid / Replacing Hydraulic Oil Filter	70
Changing Front Axle Case Oil	71
Replacing Fuel Filter Element.....	72
Lubricating Grease Fitting [2WD Model].....	72
EVERY 600 HOURS	72
Adjusting Front Axle Pivot.....	72
EVERY 800 HOURS	72
Adjusting Engine Valve Clearance	72
EVERY 1500 HOURS	72
Checking Fuel Injection Nozzle (Injection Pressure)	72
EVERY 3000 HOURS	72
Checking Injection Pump	72
EVERY 1 YEAR	72
Replacing Air Cleaner Primary Element and Secondary Element.....	72
EVERY 2 YEARS.....	72
Flushing Cooling System and Changing Coolant	72
Anti-Freeze	73
Replacing Radiator Hose (Water pipes)	74
Replacing Power Steering Hose.....	74
Replacing Fuel Hose	74
Replacing Oil Cooler Line.....	74
Replacing Intake Air Line.....	74
SERVICE AS REQUIRED.....	74
Bleeding Fuel System.....	74
Draining Clutch Housing Water	75
Replacing Fuse.....	75
Replacing Light Bulb.....	76
Replacing Head Lamp	76
STORAGE	77
TRACTOR STORAGE	77
REMOVING THE TRACTOR FROM STORAGE.....	77
TROUBLESHOOTING.....	78
ENGINE TROUBLESHOOTING	78
OPTIONS.....	79



SAFE OPERATION

Careful operation is your best insurance against an accident.

Read and understand this manual carefully before operating the tractor.

All operators, no matter how much experience they may have, should read this and other related manuals before operating the tractor or any implement attached to it. It is the owner's obligation to instruct all operators in safe operation.

1. BEFORE OPERATING THE TRACTOR

1. Know your equipment and its limitations. Read this entire manual before attempting to start and operate the tractor.
2. Pay special attention to the danger, warning and caution labels on the tractor.
3. Do not operate tractor or any implement attached to it while under the influence of alcohol, medication, controlled substances or while fatigued.
4. Before allowing other people to use your tractor, explain how to operate and have them read this manual before operation.
5. Never wear loose, torn, or bulky clothing around tractor. It may catch on moving parts or controls, leading to the risk of an accident. Use additional safety items, e.g. hard hat, safety boots or shoes, eye and hearing protection, gloves, etc., as appropriate or required.
6. Do not allow passengers to ride on any part of the tractor at anytime. The operator must remain in the tractor seat during operation.
7. Check brakes, clutch, linkage pins and other mechanical parts for improper adjustment and wear. Replace worn or damaged parts promptly. Check the tightness of all nuts and bolts regularly. (For further details, see "MAINTENANCE" section.)
8. Keep your tractor clean. Dirt, grease, and trash build up may contribute to fires and lead to personal injury.
9. Use only implements meeting the specifications listed under "IMPLEMENT LIMITATIONS" in this manual or implements approved by KUBOTA.
10. Use proper weights on the front or rear of the tractor to reduce the risk of upsets. When using the front loader, put an implement or ballast on the 3-point hitch to improve stability. Follow the safe operating procedures specified in the implement or attachment manual.
11. The narrower the tread, the greater the risk of a tractor upset. For maximum stability, adjust the wheels to the widest practical tread width for your application. (See "TIRES, WHEELS AND BALLAST" section.)

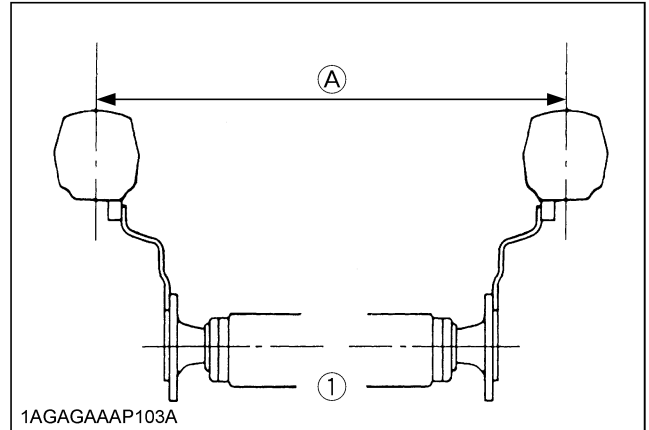

(1) Rear wheels

(A) Tread Width

12. Do not modify the tractor. Unauthorized modification may affect the function of the tractor, which may result in personal injury.

◆ CAB, ROPS

1. KUBOTA recommends the use of a CAB or Roll Over Protective Structures (ROPS) and seat belt in almost all applications. This combination will reduce the risk of serious injury or death, should the tractor be upset. Check for overhead clearance which may interfere with a CAB or ROPS.
2. Set parking brake and stop engine. Remove any obstruction that may prevent raising or folding of the ROPS. Do not allow any bystanders. Always perform function from a stable position at the rear of the tractor. Hold the top of the ROPS securely when raising or folding. Make sure all pins are installed and locked.
3. If the CAB or ROPS is loosened or removed for any reason, make sure that all parts are reinstalled correctly before operating the tractor.
4. Never modify or repair any structural member of a CAB or ROPS because welding, bending, drilling, grinding, or cutting may weaken the structure.
5. A damaged CAB or ROPS structure must be replaced, not repaired or revised.
6. If any structural member of the CAB or ROPS is damaged, replace the entire structure at your local KUBOTA Dealer.

7. If the tractor is equipped with a foldable ROPS it may be temporarily folded down only when absolutely necessary for areas with height constraints. (There is no operator protection provided by the ROPS in the folded position. For operator safety the ROPS should be placed in the upright and locked position and the seat belt fastened for all other operations.)
8. Always use the seat belt if the tractor has a CAB or ROPS.
Do not use the seat belt if a foldable ROPS is down or there is no ROPS. Check the seat belt regularly and replace if frayed or damaged.

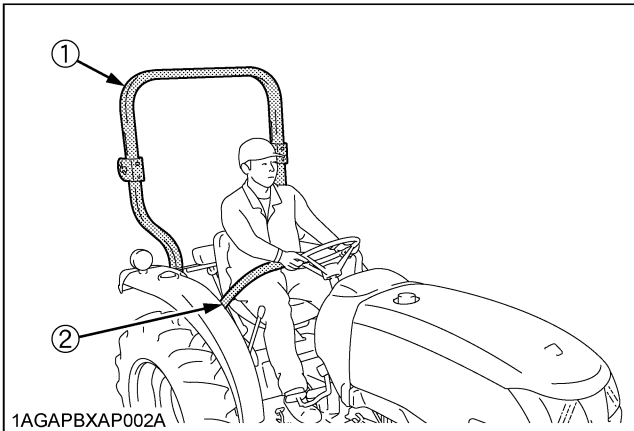

(1) ROPS
(2) Seat belt

2. OPERATING THE TRACTOR

Operator safety is a priority. Safe operation, specifically with respect to overturning hazards, entails understanding the equipment and environmental conditions at the time of use. Some prohibited uses which can affect overturning hazards include traveling and turning with implements and loads carried too high etc. This manual sets forth some of the obvious risks, but the list is not, and cannot be, exhaustive. It is the operator's responsibility to be alert for any equipment or environmental condition that could compromise safe operation.

◆ Starting

1. Always sit in the operator's seat when starting engine or operating levers or controls. Adjust seat per instructions in the operating the tractor section. Never start engine while standing on the ground.
2. Before starting the engine, make sure that all levers (including auxiliary control levers) are in their neutral positions, that the parking brake is engaged, and that both the clutch and the Power Take-Off (PTO) are disengaged or "OFF".
Fasten the seat belt if the tractor has a CAB or a foldable ROPS in the upright and locked position.

3. Do not start engine by shorting across starter terminals or bypassing the safety start switch. Machine may start in gear and move if normal starting circuitry is bypassed.
4. Do not operate or idle engine in a non-ventilated area. Carbon monoxide gas is colorless, odorless, and deadly.
5. Check before each use that operator presence controls are functioning correctly. Test safety systems. (See "Checking Engine Start System" in "EVERY 50 HOURS" in "PERIODIC SERVICE" section.)
Do not operate unless they are functioning correctly.

◆ Working

1. Pull only from the drawbar. Never hitch to axle housing or any other point except drawbar; such arrangements will increase the risk of serious personal injury or death due to a tractor upset.

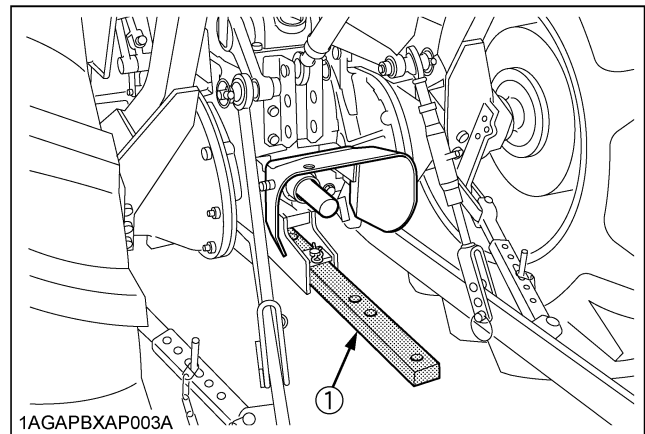

(1) Drawbar

2. For trailing PTO-driven implements, set the drawbar to the towing position.
3. Attach pulled or towed loads to the drawbar only.
4. Keep all shields and guards in place. Replace any that are missing or damaged.
5. Avoid sudden starts. To avoid upsets, slow down when turning, on uneven ground, and before stopping.
6. The tractor cannot turn with the differential locked and attempting to do so could be dangerous.
7. Do not operate near ditches, holes, embankments, or other ground surface features which may collapse under the tractor's weight. The risk of tractor upset is even higher when the ground is loose or wet. Tall grass can hide obstacles, walk the area first to be sure.
8. Watch where you are going at all times. Watch for and avoid obstacles. Be alert at row ends, near trees, and other obstructions.
9. When working in groups, always let the others know what you are going to do before you do it.
10. Never try to get on or off a moving tractor.
11. Always sit in the operator's seat when operating levers or controls.
12. Do not stand between tractor and implement or trailed vehicle unless parking brake is applied.

◆ Safety for children

Tragedy can occur if the operator is not alert to the presence of children. Children generally are attracted to machines and the work they do.

1. Never assume that children will remain where you last saw them.
2. Keep children out of the work area and under the watchful eye of another responsible adult.
3. Be alert and shut your machine down if children enter the work area.
4. Never carry children on your machine. There is no safe place for them to ride. They may fall off and be run over or interfere with your control of the machine.
5. Never allow children to operate the machine even under adult supervision.
6. Never allow children to play on the machine or on the implement.
7. Use extra caution when backing up. Look behind and down to make sure area is clear before moving.

◆ Operating on slopes

Slopes are major factor related to loss-of-control and tip-over accidents, which can result in severe injury or death. All slopes require extra caution.

1. To avoid upsets, always back up steep slopes. If you cannot back up the slope or if you feel uneasy on it, do not operate on it. Stay off slopes too steep for safe operation.
2. Driving forward out of a ditch, mired condition or up a steep slope increases the risk of a tractor to be upset backward. Always back out of these situations. Extra caution is required with four-wheel drive models because their increased traction can give the operator false confidence in the tractor's ability to climb slopes.
3. Keep all movement on slopes slow and gradual. Do not make sudden changes in speed, direction or apply brake and make sudden motions of the steering wheel.
4. Avoid disengaging the clutch or changing gears speed when climbing or going down a slope. If on a slope disengaging the clutch or changing gears to neutral could cause loss of control.
5. Special attention should be made to the weight and location of implements and loads as such will affect the stability of the tractor.
6. To improve stability on slope, set widest wheel tread as shown in "TIRES, WHEELS AND BALLAST" section.

Follow recommendations for proper ballasting.

◆ Driving the tractor on the road

1. Lock the two brake pedals together to help assure straight-line stops. Uneven braking at road speeds could cause the tractor to tip over.

[Manual Transmission Type]

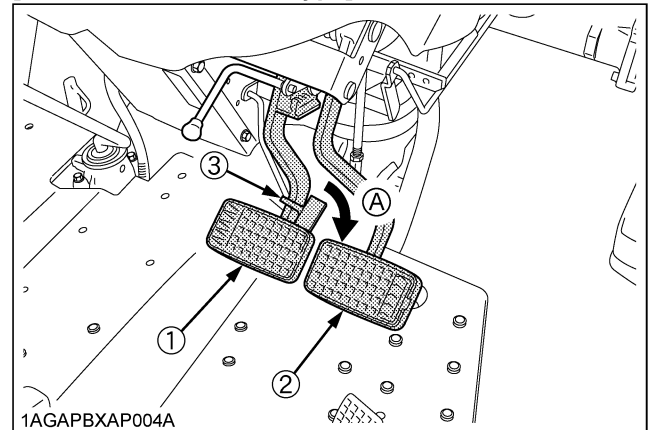

[HST Type]

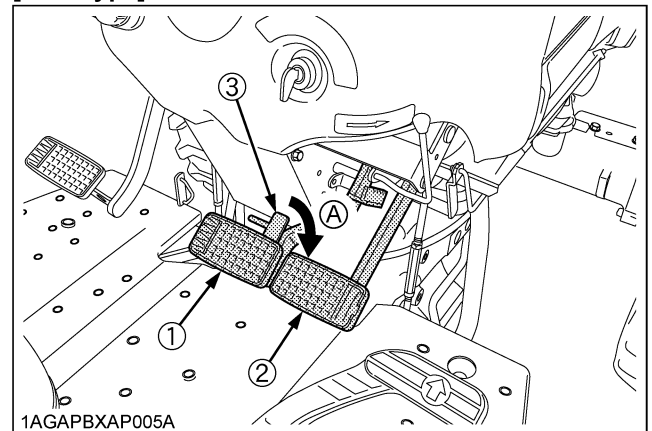

- (1) Brake Pedal (LH) (A) Whenever travelling on the road
 (2) Brake Pedal (RH)
 (3) Brake Pedal Lock

2. Check the front wheel engagement. The braking characteristics are different between two and four wheel drive. Be aware of the difference and use carefully.
3. Always slow the tractor down before turning. Turning at high speed may tip the tractor over.

4. Make sure that the Slow Moving Vehicle (SMV) sign is clean and visible. Use hazard lights and turn signals as required.

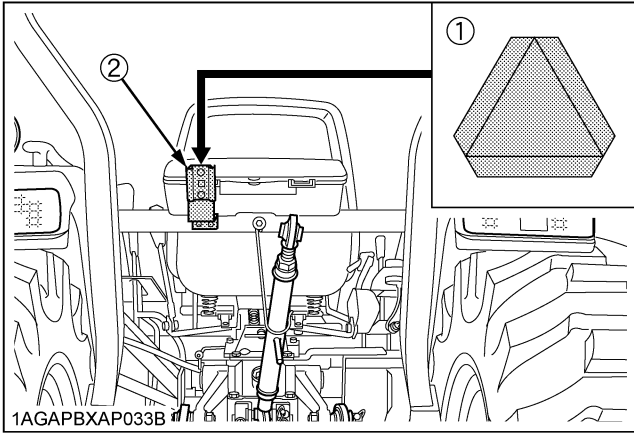

(1) SMV emblem
(2) Bracket

5. Observe all local traffic and safety regulations.
6. Turn the headlights on. Dim them when meeting another vehicle.
7. Drive at speeds that allow you to maintain control at all times.
8. Do not apply the differential lock while traveling at road speeds. The tractor may run out of control.
9. Avoid sudden motions of the steering wheel as they can lead to a dangerous loss of stability. The risk is especially great when the tractor is traveling at road speeds.
10. Keep the ROPS in the "UP" position and wear the seat belt when driving the tractor on the road. Otherwise, you will not be protected in the event of a tractor roll-over.
11. Do not operate an implement while the tractor is on the road. Lock the 3-point hitch in the raised position.
12. When towing other equipment, use a safety chain and place an SMV emblem on it as well.

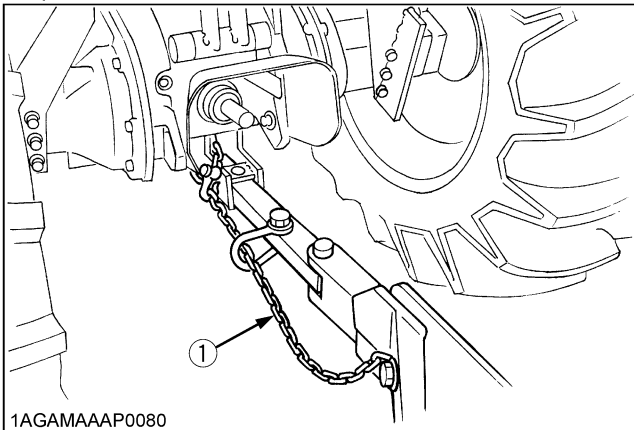

(1) Safety chain

13. Set the implement lowering speed knob in the "LOCK" position to hold the implement in the raised position.

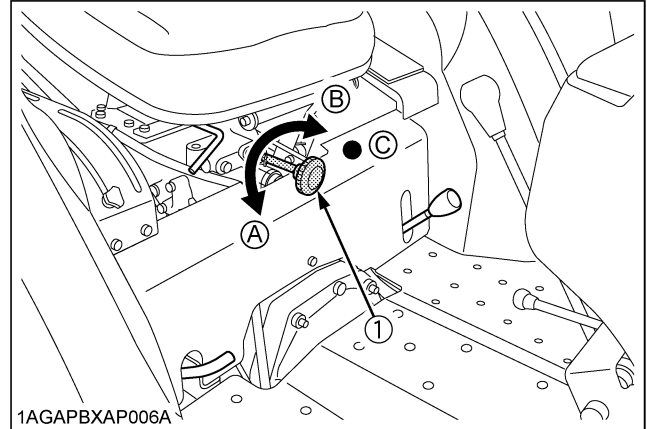

(1) 3-point hitch lowering speed knob
(A) "FAST"
(B) "SLOW"
(C) "LOCK"

3. PARKING THE TRACTOR

1. Disengage the PTO, lower all implements to the ground, place all control levers in their neutral positions, set the parking brake, stop the engine, remove the key from the ignition and lock the cab door (if equipped). Leaving transmission in gear with the engine stopped will not prevent tractor from rolling. (HST type)
2. Make sure that the tractor has come to a complete stop before dismounting.
3. Avoid parking on steep slopes, if at all possible park on a firm and level surface; if not, park across a slope with chock the wheels.
Failure to comply with this warning may allow the tractor to move and could cause injury or death.

4. OPERATING THE PTO

1. Wait until all moving components have completely stopped before getting off the tractor, connecting, disconnecting, adjusting, cleaning, or servicing any PTO driven equipment.

- Keep the PTO shaft cover in place at all times. Replace the PTO shaft cap when the shaft is not in use.

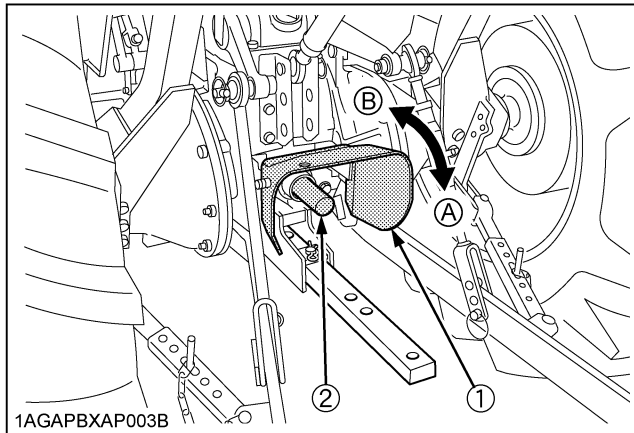

(1) PTO Shaft cover (A) "NORMAL POSITION"
(2) PTO Shaft cap (B) "RAISED POSITION"

- Before installing or using PTO driven equipment, read the manufacturer's manual and review the safety labels attached to the equipment.
- When operating stationary PTO driven equipment, always apply the tractor parking brake and place chocks behind and in front of the rear wheels. Stay clear of all rotating parts. Never step over rotating parts.

5. USING 3-POINT HITCH

- Use the 3-point hitch only with equipment designed for 3-point hitch usage.
- When using a 3-point hitch mounted implement, be sure to install the proper counterbalance weight on the front of the tractor.

6. SERVICING THE TRACTOR

Before servicing the tractor, park it on a firm, flat and level surface, set the parking brake, lower all implements to the ground, place the gear shift lever in neutral, stop the engine and remove the key.

- Allow the tractor time to cool off before working on or near the engine, muffler, radiator, etc.
- Always stop the engine before refueling. Avoid spills and overfilling.
- Do not smoke when working around battery or when refueling. Keep all sparks and flames away from battery and fuel tank. The battery presents an explosive hazard, because it gives off hydrogen and oxygen especially when recharging.
- Before "jump starting" a dead battery, read and follow all of the instructions. (See "JUMP STARTING" in "OPERATING THE ENGINE" section.)

- Keep first aid kit and fire extinguisher handy at all times.
- Do not remove radiator cap while coolant is hot. When cool, slowly rotate cap to the first stop and allow sufficient time for excess pressure to escape before removing the cap completely. If the tractor has a coolant recovery tank, add coolant or water to the tank, not the radiator. (See "Checking Coolant Level" in "DAILY CHECK" in "PERIODIC SERVICE" section.)
- Disconnect the battery's ground cable before working on or near electric components.
- To avoid the possibility of battery explosion, do not use or charge the refillable type battery if the fluid level is below the LOWER (lower limit level) mark. Check the fluid level regularly and add distilled water as required so that the fluid level is between the UPPER and LOWER levels.
- To avoid sparks from an accidental short circuit, always disconnect the battery's ground cable (-) first and reconnect it last.

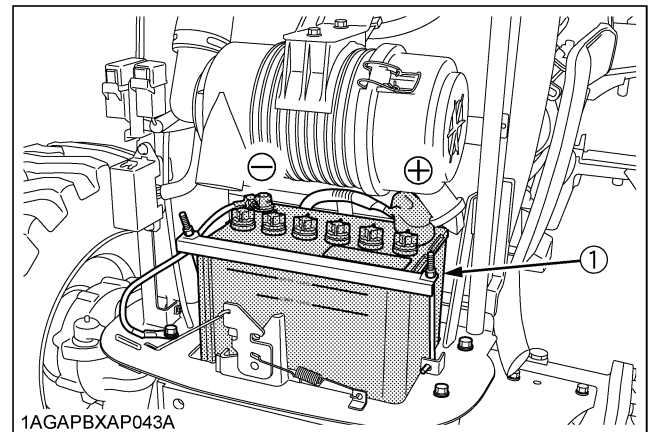

(1) Battery

- Do not attempt to mount a tire on a rim. This should be done by a qualified person with the proper equipment.
- Always maintain the correct tire pressure. Do not inflate tires above the recommended pressure shown in the operator's manual.

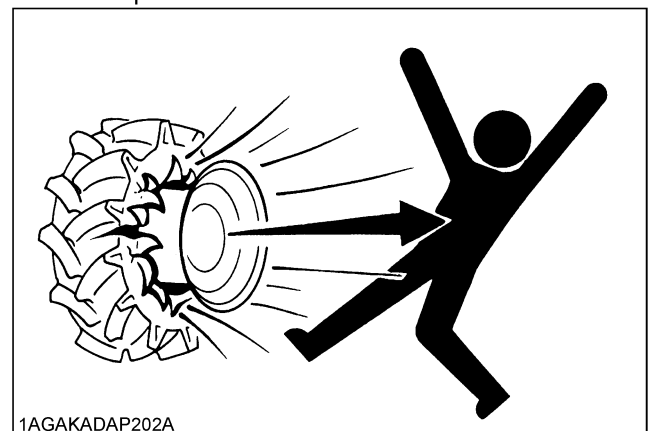

- Securely support the tractor when either changing wheels or adjusting the wheel tread width.

13. Make sure that wheel bolts have been tightened to the specified torque.
14. Do not work under any hydraulically supported devices. They can settle, suddenly leak down, or be accidentally lowered. If it is necessary to work under tractor or any machine elements for servicing or adjustment, securely support them with stands or suitable blocking beforehand.
15. Escaping hydraulic fluid under pressure has sufficient force to penetrate skin, causing serious personal injury. Before disconnecting hydraulic lines, be sure to release all residual pressure. Before applying pressure to the hydraulic system, make sure that all connections are tight and that all lines, pipes, and hoses are free of damage.

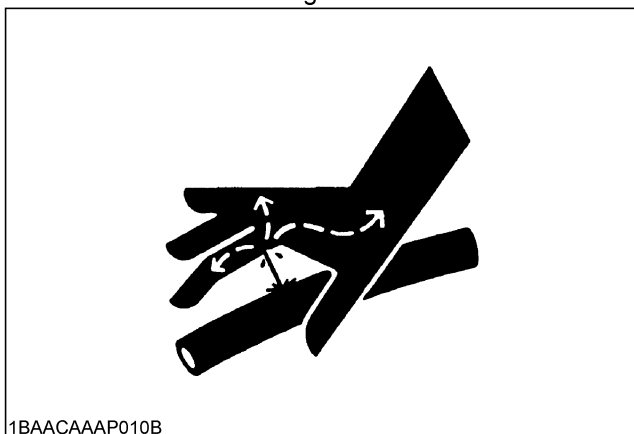

16. Fluid escaping from pinholes may be invisible. Do not use hands to search for suspected leaks; use a piece of cardboard or wood. Use of safety goggles or other eye protection is also highly recommended. If injured by escaping fluid, see a medical doctor at once. This fluid will produce gangrene or severe allergic reaction.

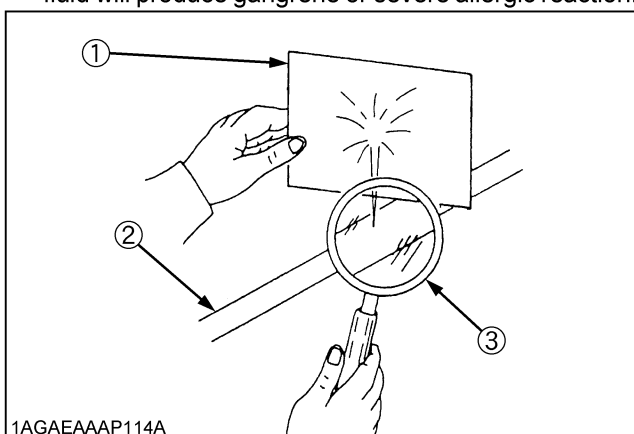

- (1) Cardboard
- (2) Hydraulic line
- (3) Magnifying glass

7. DANGER, WARNING AND CAUTION LABELS

(1) Part No. TC430-9848-1

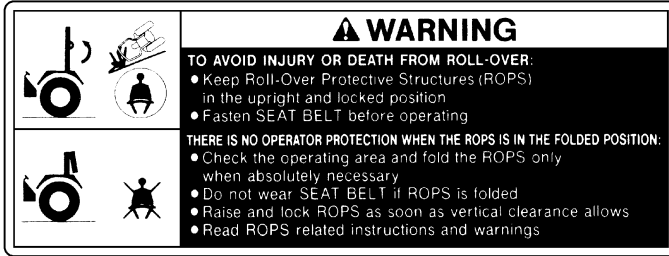

1AGAMAAAP2370

(2) Part No. TC430-4933-1 [Manual Transmission type]

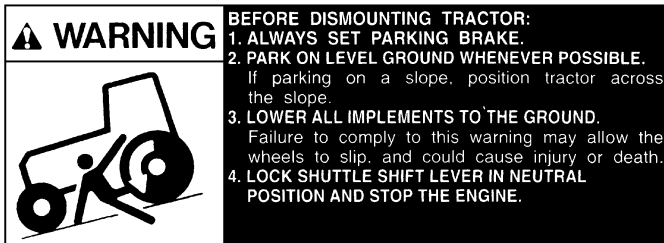

1AGAMAAAP400A

(2) Part No. TC404-4933-1 [HST type]

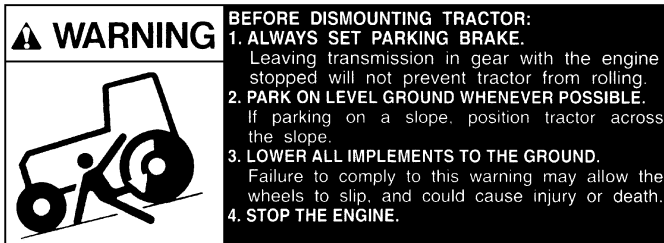

1AGAMAAAP3720

(3) Part No. TC404-4956-1

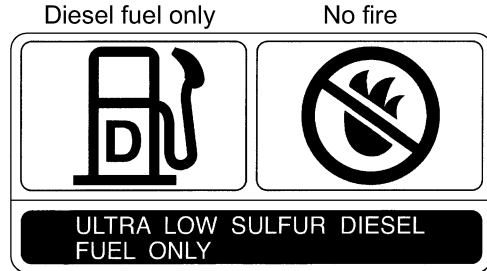

1AGAIDHAP154E

(4) Part No. TC402-4958-1

Do not get your hands close to engine fan and fan belt.



1AGAMAAAP2620

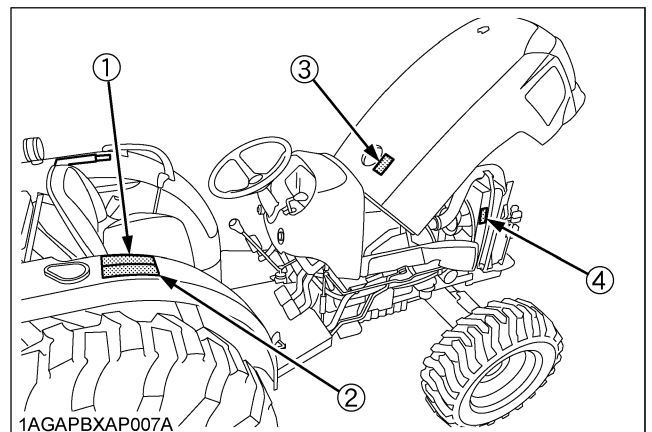

1AGAPBXAP007A

1AGAPBXAP010A

(1) Part No. TC430-4997-1

⚠ CAUTION

TO AVOID PERSONAL INJURY:

1. Read and understand the operator's manual before operation.
2. Before starting the engine, make sure that everyone is at a safe distance from the tractor and that the PTO is OFF.
3. Do not allow passengers on the tractor at any time.
4. Before allowing other people to use the tractor, have them read the operator's manual.
5. Check the tightness of all nuts and bolts regularly.
6. Keep all shields in place and stay away from all moving parts.
7. Lock the two brake pedals together before driving on the road.
8. Slow down for turns, or rough roads, or when applying individual brakes.
9. On public roads use SMV emblem and hazard lights, if required by local traffic and safety regulations.
10. Pull only from the drawbar.
11. Before dismounting, lower the implement to the ground, set the parking brake, stop the engine and remove the key.
12. Securely support tractor and implements before working underneath.

1AGAMAAAP2390

(4) Part No. TC402-4958-1
Do not get your hands close to engine fan and fan belt.



1AGAMAAAP2620

(2) Part No. TC430-4744-1

⚠ WARNING

Operation of this equipment may create sparks that can start fires around dry vegetation. A spark arrester may be required. The operator should contact local fire agencies for laws or regulations relating to fire prevention requirements.

1AGAIHFAP069A

(3) Part No. TC430-4965-1

⚠ DANGER

TO AVOID POSSIBLE INJURY OR DEATH FROM A MACHINE RUNAWAY.

1. Do not start engine by shorting across starter terminals or bypassing the safety start switch. Machine may start in gear and move if normal starting circuitry is bypassed.
2. Start engine only from operator's seat with transmission and PTO OFF. Never start engine while standing on the ground.

1AGAMAAAP2450

(5) Part No. TC422-4958-1
Do not touch hot surface like muffler, etc.



1AGAMAAAP2400

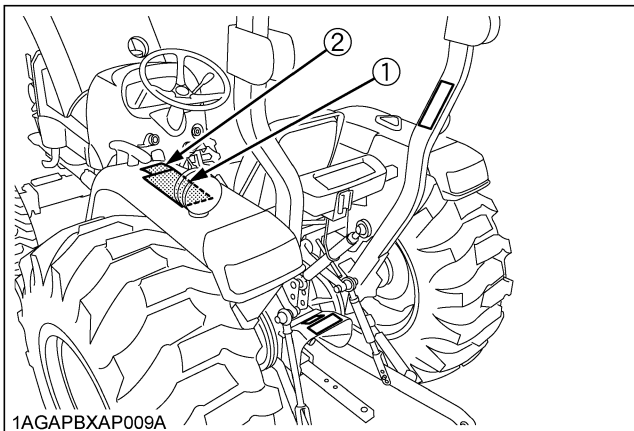

1AGAPBXAP009A

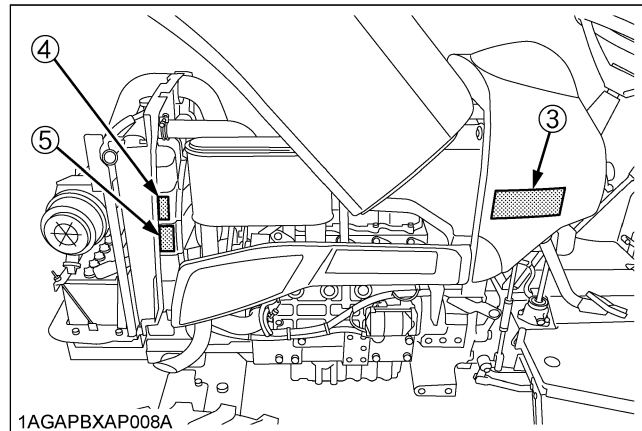

1AGAPBXAP008A

1AGAPBXAP011A

(1) Part No. TC430-4959-1

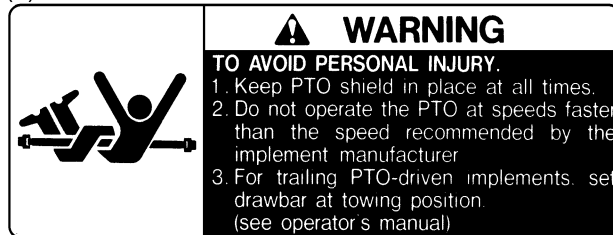

1AGAMAAAP2470

(2) Part No. TC430-4935-1

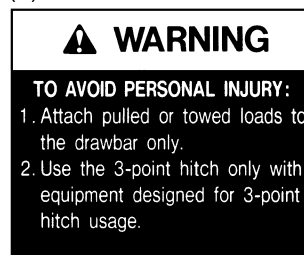

1AGAMAAAP2500

(3) Part No. TC430-9554-1

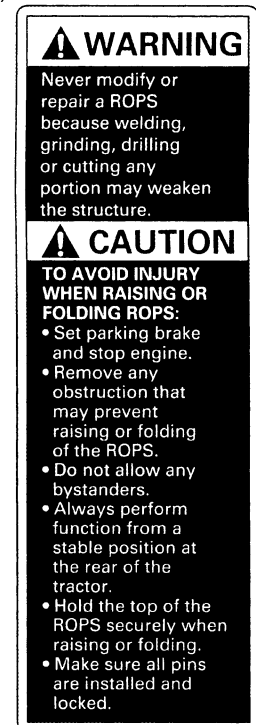

1AGAMAAAP2380

(4) Part No. TC430-3013-1

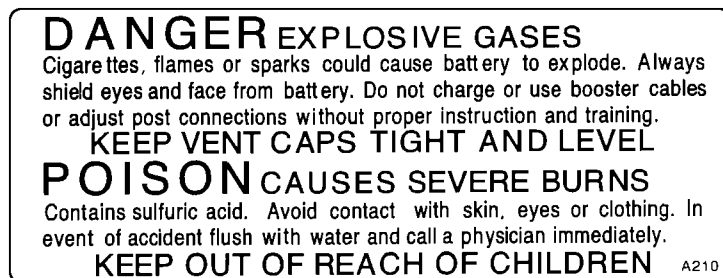

1AGAPBXAP0720

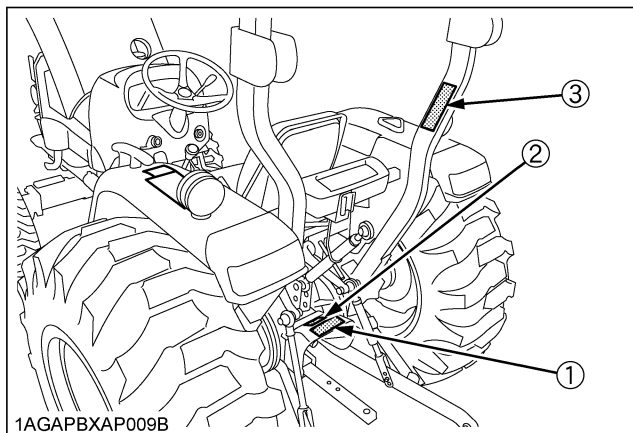

1AGAPBXAP009B

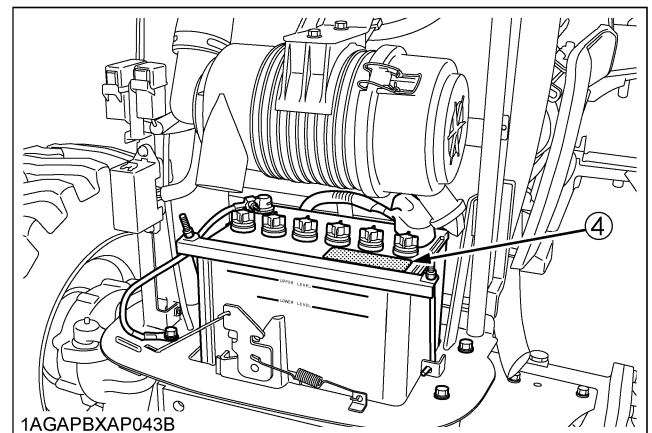

1AGAPBXAP043B

1AGAPBXAP012A

8. CARE OF DANGER, WARNING AND CAUTION LABELS

1. Keep danger, warning and caution labels clean and free from obstructing material.
2. Clean danger, warning and caution labels with soap and water, dry with a soft cloth.
3. Replace damaged or missing danger, warning and caution labels with new labels from your local KUBOTA Dealer.
4. If a component with danger, warning and caution label(s) affixed is replaced with new part, make sure new label(s) is (are) attached in the same location(s) as the replaced component.
5. Mount new danger, warning and caution labels by applying on a clean dry surface and pressing any bubbles to outside edge.

SERVICING OF TRACTOR

Your dealer is interested in your new tractor and has the desire to help you get the most value from it. After reading this manual thoroughly, you will find that you can do some of the regular maintenance yourself.

However, when in need of parts or major service, be sure to see your KUBOTA Dealer.

For service, contact the KUBOTA Dealership from which you purchased your tractor or your local KUBOTA Dealer. When in need of parts, be prepared to give your dealer the tractor, CAB/ROPS and engine serial numbers.

Locate the serial numbers now and record them in the space provided.

	Type	Serial No.
Tractor		
CAB / ROPS		
Engine		
Date of Purchase		
Name of Dealer		
(To be filled in by purchaser)		

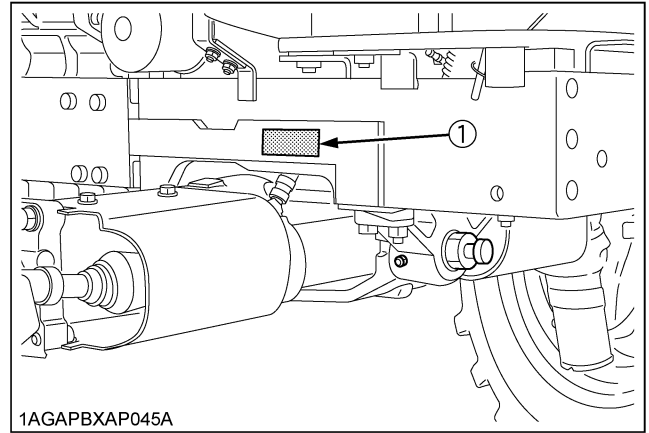

(1) Tractor serial number

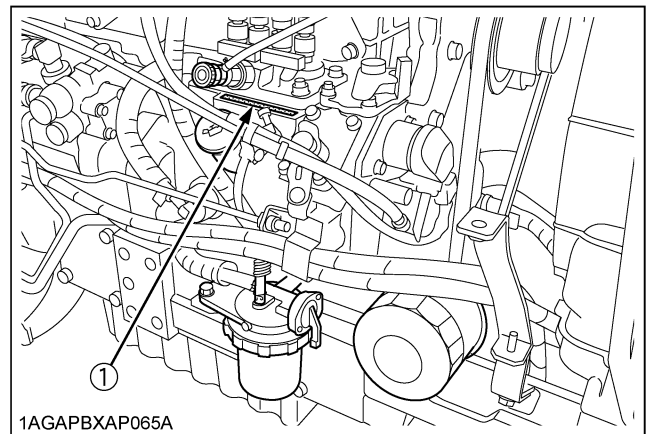

(1) Engine serial number

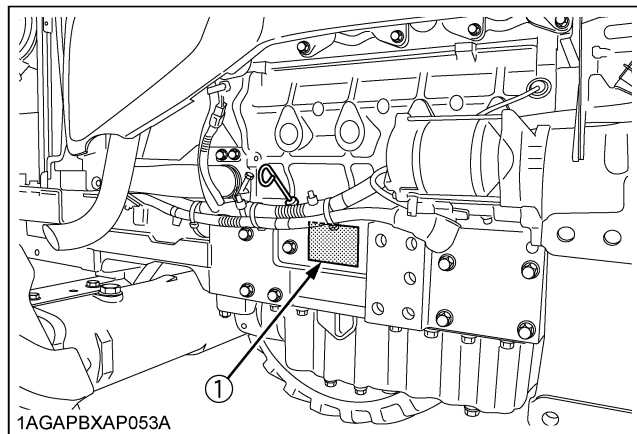

(1) Tractor identification plate

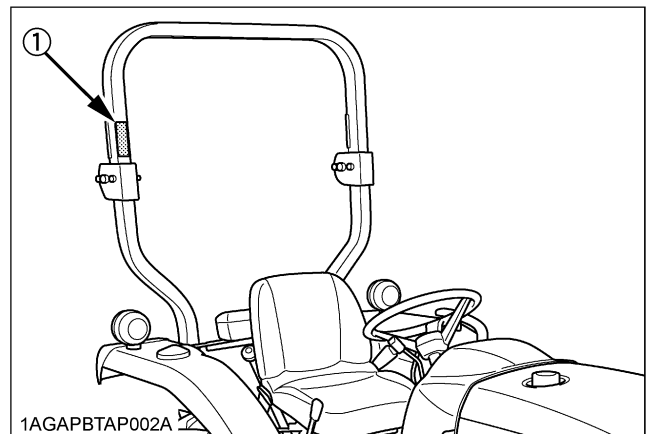

(1) ROPS identification plate (ROPS Serial No.)

SPECIFICATIONS

SPECIFICATION TABLE

Model			L4600			
			Manual Transmission		HST	
			2WD	4WD		
Engine	Model		V2203-M-E3-LB3			
	Type		Indirect injection, Vertical, Water-Cooled 4 cycle diesel			
	Number of cylinders		4			
	Total displacement	L (cu.in.)	2.197 (134.1)			
	Bore and stroke	mm (in.)	87 x 92.4 (3.4 x 3.6)			
	Rated revolution	rpm	2600			
	Low idling revolution	rpm	900 - 1000			
	Net power*	kW (HP) / rpm	32.7 (43.8) / 2600			
	PTO power* (factory observed)	kW (HP) / rpm	28.6 (38.3) / 2600	27.4 (36.8) / 2600		
	Maximum torque : Gross	N-m (ft-lbs.)	143.2 (105.6)			
	Battery capacity		12V, RC : 133min, CCA : 582A			
Capacities	Fuel tank	L (U.S.gals.)	48 (12.7)			
	Engine crankcase (with filter)	L (U.S.qts.)	7.6 (8.0)			
	Engine coolant	L (U.S.qts.)	6.5 (6.9)			
	Transmission case	L (U.S.gals.)	40 (10.6)			
Dimensions	Overall length (without 3p)	mm (in.)	3120 (122.8)	2995 (117.9)		
	Overall width (min. tread)	mm (in.)	1585 (62.4)			
	Overall height (with ROPS)	mm (in.)	2330 (91.7)			
	Wheel base	mm (in.)	1850 (72.8)	1845 (72.6)		
	Min. ground clearance	mm (in.)	385 (15.2)			
	Tread	Front	mm (in.)	1280 (50.4), 1380 (54.3), 1480 (58.3), 1580 (62.2)	1155 (45.5)	
		Rear	mm (in.)	1180 (46.5), 1200 (47.2), 1300 (51.2), 1450 (57.1), 1545 (60.8)		
Weight (with ROPS)		kg (lbs.)	1410 (3109)	1445 (3186)	1450 (3197)	
Traveling system	Standard tire size	Front	7.5L - 15	8.3 - 16		
		Rear	14.9 - 24			
	Clutch		Dry type single stage			
	Steering		Hydrostatic power steering			
	Transmission		Gear shift, 8 forward and 8 reverse	Hydrostatic transmission 3 range speed		
	Braking system		Mechanical, Wet disk type			
	Min. turning radius (with brake)	m (feet)	2.7 (8.9)	2.6 (8.5)		





Model			L4600		
			Manual Transmission	HST	
			2WD	4WD	
Hydraulic unit	Hydraulic control system		Position control		
	Pump capacity	L (U.S.gals.) / min	29.4 (7.8)		
	Three point hitch		Category 1		
	Max. lift force	At lift points	kg (lbs.)	1300 (2870)	
		24 in. behind lift points	kg (lbs.)	1053 (2320)	
System pressure		MPa (kgf / cm ²) [psi]	17.7 (180) [2560]		
PTO	Rear PTO		SAE 1-3/8, 6-splines		
	PTO / Engine speed	rpm	540 / 2475	540 / 2640	

NOTE: *Manufacturer's estimate The company reserves the right to change the specifications without notice.

TRAVELING SPEEDS

[Manual Transmission Type]

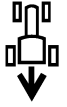

(At rated engine rpm)

Model			L4600	
Tire size (Rear)			14.9-24	
	Range gear shift lever	Main gear shift lever	km/h	mph
Forward 	Low 	1	2.2	1.4
		2	2.8	1.7
		3	4.6	2.8
		4	6.7	4.2
	High 	1	8.0	5.0
		2	10.0	6.2
		3	16.3	10.1
		4	24.0	14.9
Reverse 	Low 	1	2.1	1.3
		2	2.7	1.7
		3	4.4	2.7
		4	6.4	4.0
	High 	1	7.7	4.8
		2	9.6	6.0
		3	15.6	9.7
		4	23.0	14.3

The company reserves the right to change the specifications without notice

[HST Type]

(At rated engine rpm)

Model		L4600	
Tire size (Rear)		14.9-24	
	Range shift lever	km/h	mph
Forward 	L	5.9	3.7
	M	12.2	7.6
	H	25.4	15.8
Reverse 	L	5.3	3.3
	M	11.0	6.8
	H	22.9	14.2

The company reserves the right to change the specifications without notice

IMPLEMENT LIMITATIONS

The KUBOTA Tractor has been thoroughly tested for proper performance with implements sold or approved by KUBOTA. Use with implements which are not sold or approved by KUBOTA and which exceed the maximum specifications listed below, or which are otherwise unfit for use with the KUBOTA Tractor may result in malfunctions or failures of the tractor, damage to other property and injury to the operator or others. [Any malfunctions or failures of the tractor resulting from use with improper implements are not covered by the warranty.]

	Tread (max. width) with farm tires			Lower link end max. lifting capacity W 0
	Front		Rear	
	2WD	4WD		
L4600	1580 mm (62.2 in.)	1155 mm (45.5 in.)	1545 mm (60.8 in.)	1300 kg (2870 lbs.)

	Actual figures		
	Implement weight W 1 and/or size	Max. Drawbar Load W 2	Trailer loading weight W 3 Max. capacity
L4600	As in the following list (Shown on the next page)	650 kg (1430 lbs.)	3000 kg (6600 lbs.)

Lower link end max. hydraulic lifting capacityW 0
 Implement weightThe implement's weight which can be put on the lower link : W 1
 Max. drawbar loadW 2
 Trailer loading weightThe max. loading weight for trailer (without trailer's weight) : W 3

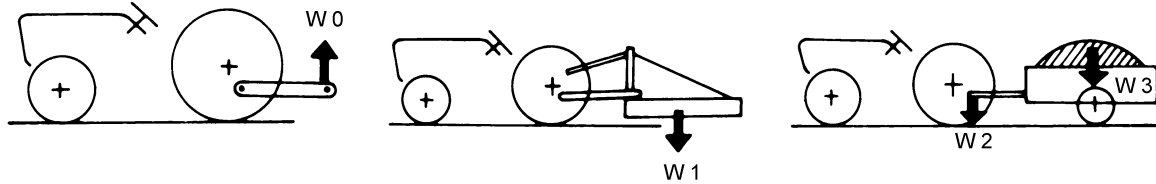

1AGAIAZAP121B

NOTE :
 ● Implement size may vary depending on soil operating conditions.

6 IMPLEMENT LIMITATIONS

No.	Implement	Remarks		L4600
1	Trailer	Max. load capacity	kg (lbs.)	3000 (6600)
		Max. drawbar load	kg (lbs.)	650 (1430)
2	Mid-mount	Max. cutting width	mm (in.)	---
		Max. weight	kg (lbs.)	---
	Rotary-Cutter	Max. cutting width	mm (in.)	1829 (72)
		Max. weight	kg (lbs.)	400 (880)
	Flail Mower	Max. cutting width	mm (in.)	1524 (60)
		Max. weight	kg (lbs.)	400 (880)
	Sickle Bar	Max. cutting width	mm (in.)	2133 (84)
		Max. weight	kg (lbs.)	500 (1100)
3	Rear mounted	Max. tank capacity	L (gals.)	400 (106)
	Pull type	Max. tank capacity	L (gals.)	1200 (317)
4	Rotary Tiller	Max. tilling width	mm (in.)	1520 (60)
5	Bottom Plow	Max. size		14 in. x 2
6	Disk harrow : Pull type	Max. harrowing width	mm (in.)	1981 (78)
		Max. weight	kg (lbs.)	400 (880)
7	Chisel Plow	Max. width	mm (in.)	1829 (72)
		Max. weight	kg (lbs.)	350 (770)
8	Broad Caster	Max. tank capacity	L (gals.)	300 (80)
		Max. weight	kg (lbs.)	100 (220)
9	Manure Spreader	Max. capacity	kg (lbs.)	2000 (4400)
10	Cultivator	Max. width	mm (in.)	2134 (84)
		Number of rows		2
		Max. weight	kg (lbs.)	400 (880)
11	Front Blade	Max. cutting width	mm (in.)	1829 (72)
		Max. oil pressure	MPa (psi)	17.2 (2490)
		Sub frame		Necessary
12	Rear Blade	Max. cutting width	mm (in.)	1829 (72)
		Max. oil pressure	MPa (psi)	17.2 (2490)
13	Front-end Loader	Max lifting capacity	kg (lbs.)	700 (1545)
		Max. oil pressure	MPa (psi)	18.0 (2560)
		Sub frame		Necessary
14	Box Blade	Max. cutting width	mm (in.)	1651 (65)
		Max. weight	kg (lbs.)	350 (770)
15	Back Hoe	Max. digging depth	mm (in.)	2288 (90)
		Max. weight	kg (lbs.)	450 (990)
		Sub frame		Necessary
16	Snow Blade	Max. width	mm (in.)	1829 (72)
		Max. weight	kg (lbs.)	350 (770)
17	Snow Blower	Max. working width	mm (in.)	1676 (66)
		Max. weight	kg (lbs.)	280 (620)

NOTE :

- Implement size may vary depending on soil operating conditions.

INSTRUMENT PANEL AND CONTROLS

■ Instrument Panel, Switches and Hand Controls

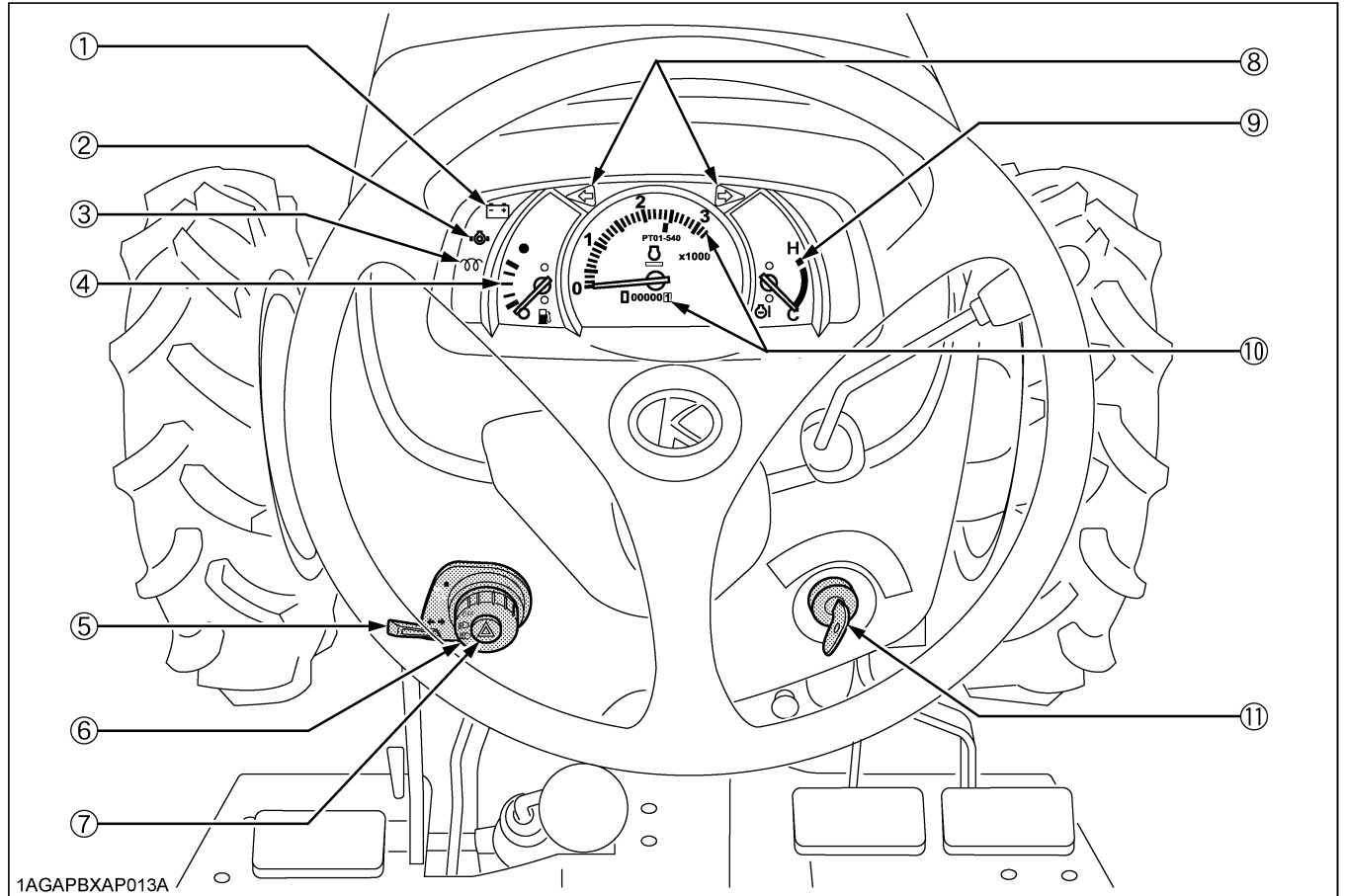

1AGAPBXAP013A

ILLUSTRATED CONTENTS

(1)	Electrical charge lamp.....	28
(2)	Engine oil pressure lamp.....	28
(3)	Glow plug indicator.....	14
(4)	Fuel gauge.....	29
(5)	Turn signal switch.....	20
(6)	Head light switch.....	20
(7)	Hazard light switch.....	20
(8)	Turn signal / Hazard light indicator.....	20
(9)	Coolant temperature gauge.....	29
(10)	Hourmeter / Tachometer.....	29
(11)	Key switch.....	11

■ Foot and Hand Controls

◆ Manual Transmission Type

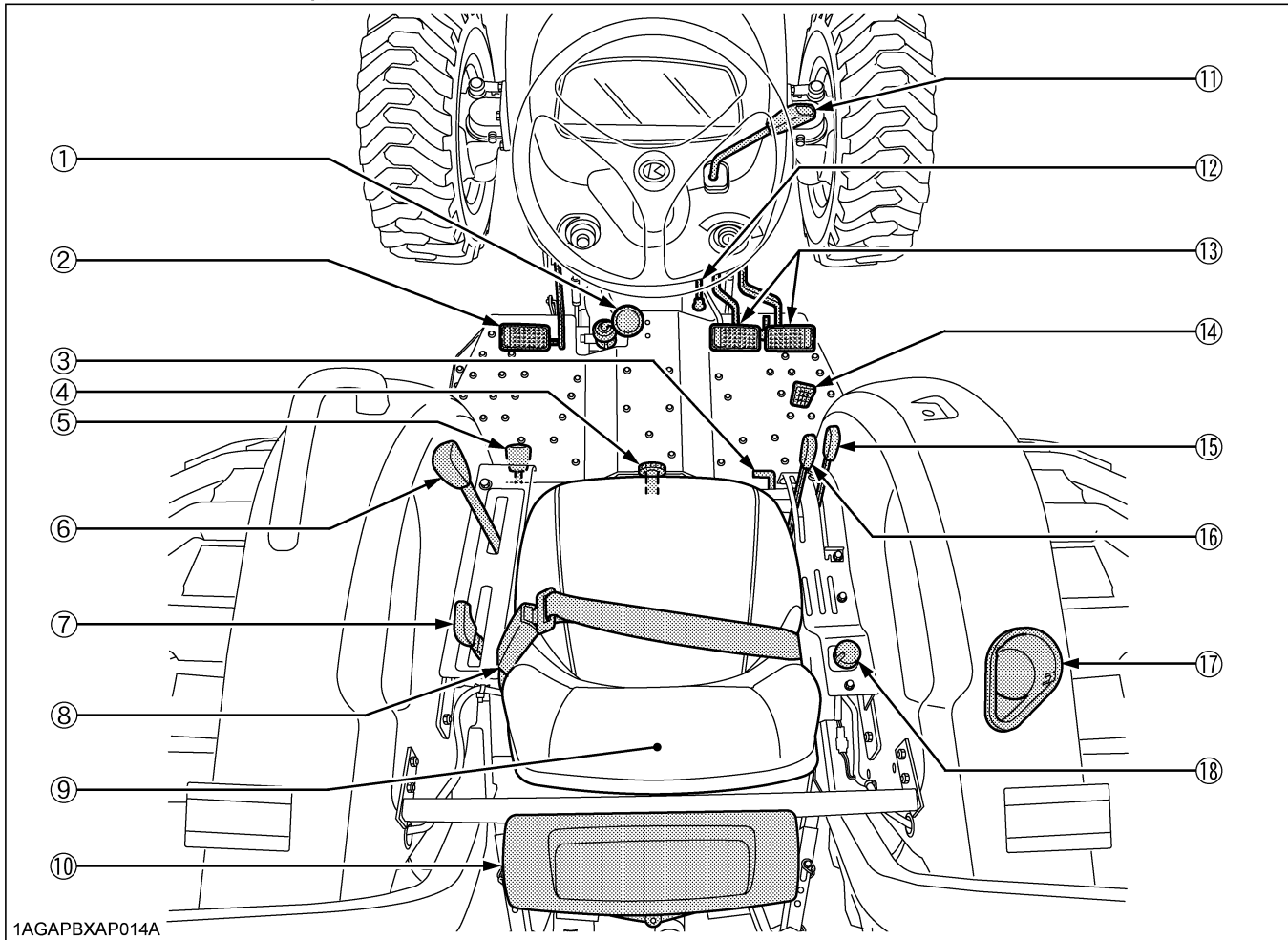

1AGAPBXAP014A

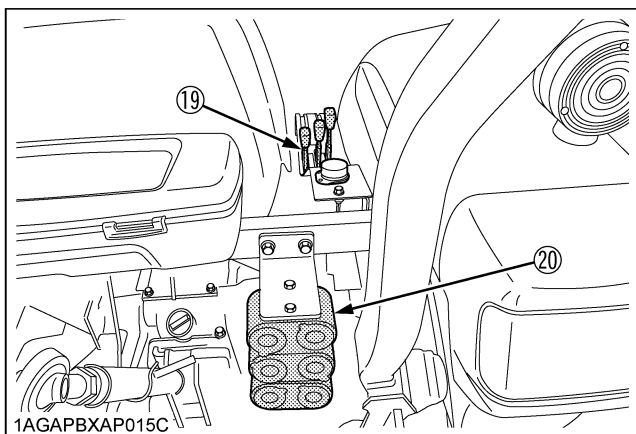

1AGAPBXAP015C

ILLUSTRATED CONTENTS

(1)	Main gear shift lever.....	23
(2)	Clutch pedal.....	22
(3)	Differential lock pedal.....	31
(4)	3-Point hitch lowering speed knob.....	40
(5)	Front wheel drive lever (4WD Type).....	24
(6)	Synchro-shuttle shift lever.....	23
(7)	Range gear shift lever.....	23
(8)	Seat belt.....	20
(9)	Operator's seat.....	19
(10)	Tool box.....	-
(11)	Hand throttle lever.....	24
(12)	Parking brake lever.....	30
(13)	Brake pedal.....	21
(14)	Foot throttle.....	24
(15)	Position control lever.....	39
(16)	Draft control lever (If equipped).....	39
(17)	Cup holder.....	-
(18)	PTO clutch control switch.....	33
(19)	Remote control valve lever (if equipped).....	41
(20)	Remote control valve coupler (if equipped).....	42

◆ HST Type

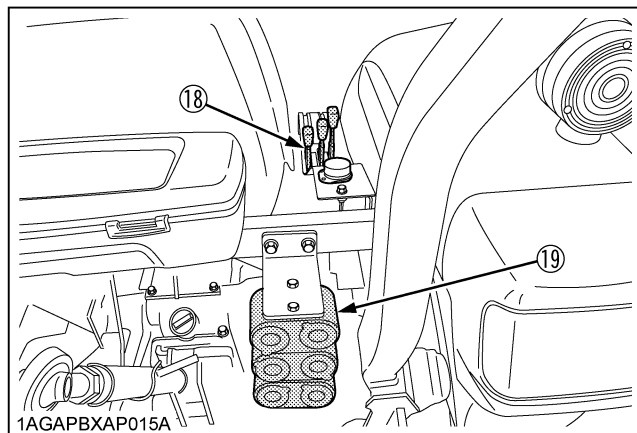
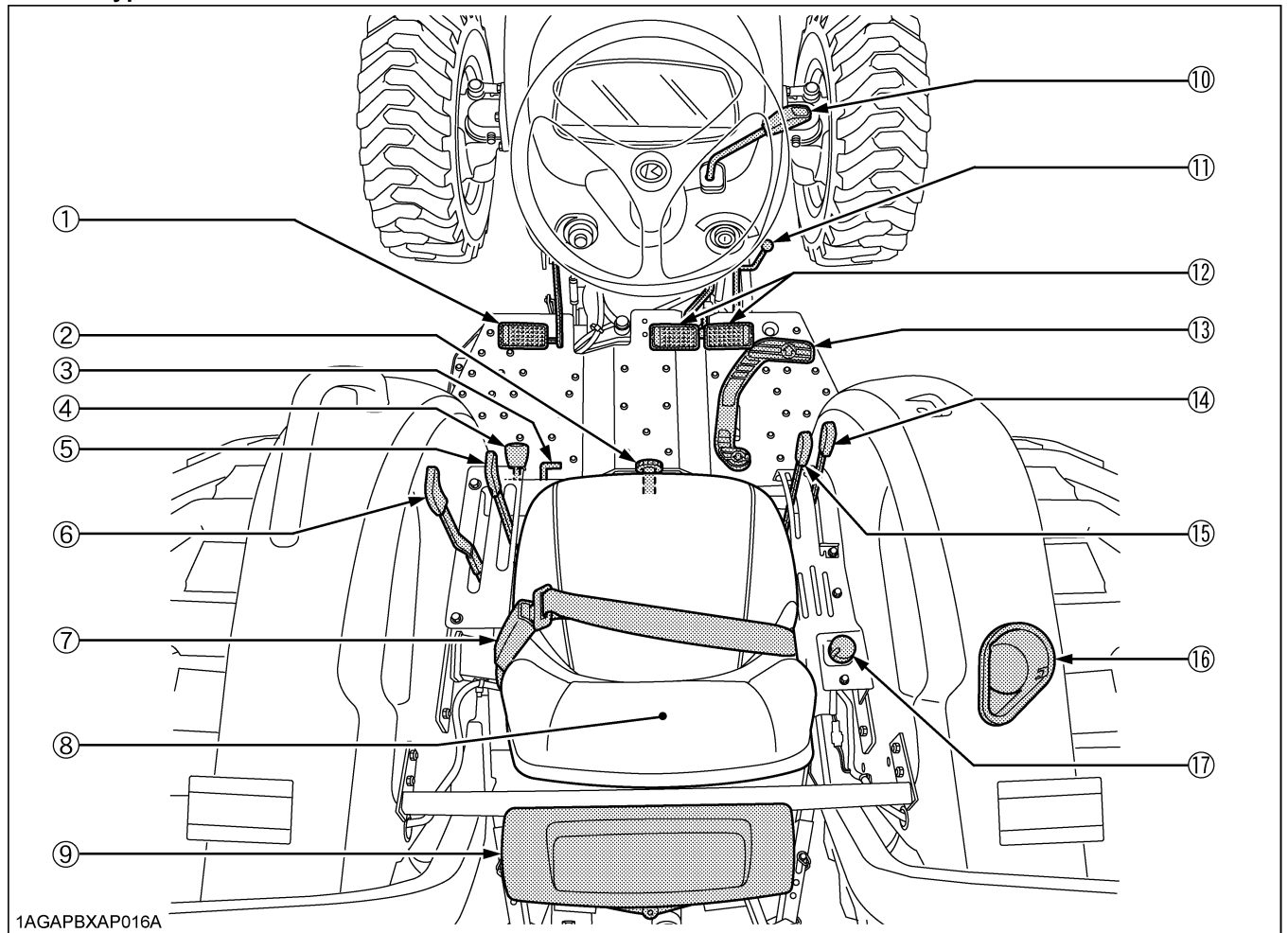

ILLUSTRATED CONTENTS

(1)	Clutch pedal.....	22
(2)	3-Point hitch lowering speed knob.....	40
(3)	Differential lock pedal.....	31
(4)	Front wheel drive lever (4WD Type).....	26
(5)	Range gear shift lever.....	25
(6)	Cruise control lever.....	27
(7)	Seat belt.....	20
(8)	Operator's seat.....	19
(9)	Tool box.....	-
(10)	Hand throttle lever.....	26
(11)	Parking brake lever.....	30
(12)	Brake pedal.....	21
(13)	Speed control pedal.....	27
(14)	Position control lever.....	39
(15)	Draft control lever (If equipped).....	39
(16)	Cup holder.....	-
(17)	PTO clutch control switch.....	33
(18)	Remote control valve lever (if equipped).....	41
(19)	Remote control valve coupler (if equipped).....	42

PRE-OPERATION CHECK

DAILY CHECK

To prevent trouble from occurring, it is important to know the condition of the tractor well. Check it before starting.



CAUTION

To avoid personal injury:

- **Be sure to check and service the tractor on a level surface with the engine shut off and the parking brake "ON" and implement lowered to the ground.**

Check item

- Walk around inspection
- Check engine oil level
- Check transmission oil level
- Check coolant level
- Clean grill and radiator screen
- Clean oil cooler [HST model]
- Check air cleaner evacuator valve
(When used in a dusty place)
- Check brake and clutch pedal
- Check indicators, gauges and meter
- Check lights
- Check wire harness
- Check seat belt and ROPS
- Check movable parts
- Refuel
(See "DAILY CHECK" in "PERIODIC SERVICE" section.)
- Care of danger, warning and caution labels
(See "DANGER, WARNING AND CAUTION LABELS" in "SAFE OPERATION" section.)

OPERATING THE ENGINE



CAUTION

To avoid personal injury:

- Read "Safe Operation" in the front of this manual.
- Read the danger, warning and caution labels located on the tractor.
- To avoid the danger of exhaust fume poisoning, do not operate the engine in a closed building without proper ventilation.
- Never start engine while standing on ground. Start engine only from operator's seat.
- Make it a rule to set all shift levers to the "NEUTRAL" positions and to place PTO clutch control switch in "OFF" position before starting the engine.

IMPORTANT :

- Do not use starting fluid or ether.
- To protect the battery and the starter, make sure that the starter is not continuously turned for more than 10 seconds.

STARTING THE ENGINE

1. Make sure the parking brake is set.

1. To set the parking brake;
 - (1) Interlock the brake pedals.
 - (2) Depress the brake pedals.
 - (3) Latch the brake pedals with the parking brake lever.
2. To release the parking brake, depress the brake pedals again.

[Manual Transmission Type]

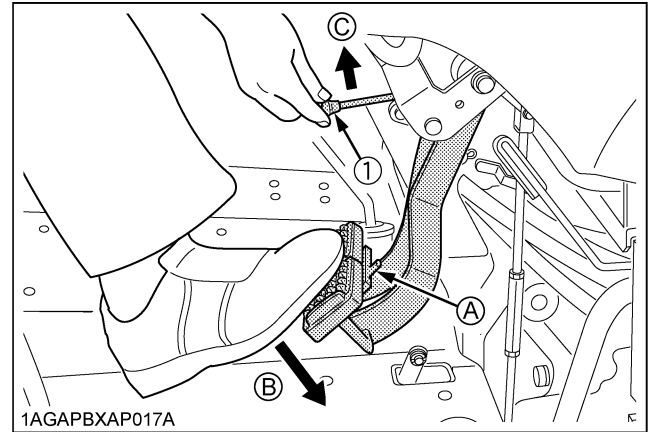

(1) Parking brake lever

(A) Interlock the brake pedals

(B) "DEPRESS"

(C) "PULL"

[HST Type]

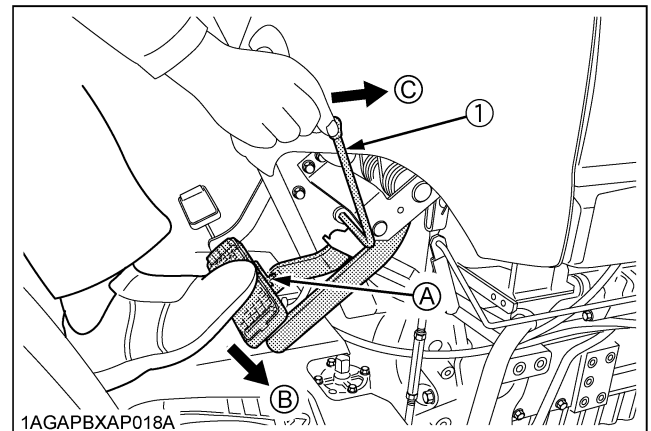

(1) Parking brake lever

(A) Interlock the brake pedals

(B) "DEPRESS"

(C) "PUSH"

IMPORTANT :

- To prevent damage to the parking brake lever, make sure that brake pedals are fully depressed before pushing or pulling the parking brake lever.

2. Make sure the fuel cock is in the open position.

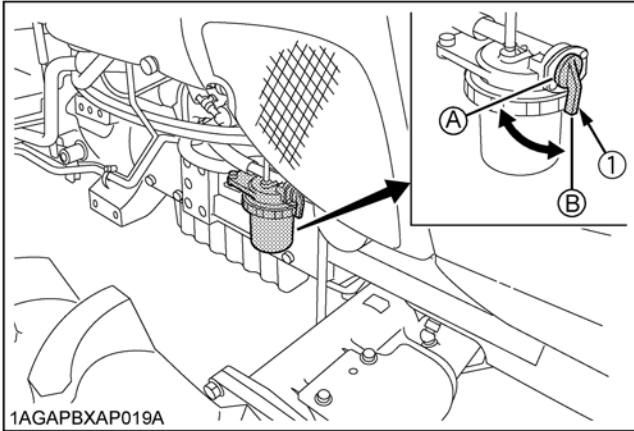

(1) Fuel cock

(A) "CLOSE"
(B) "OPEN"

3. Place the shift levers in "NEUTRAL" position.

[Manual Transmission Type]

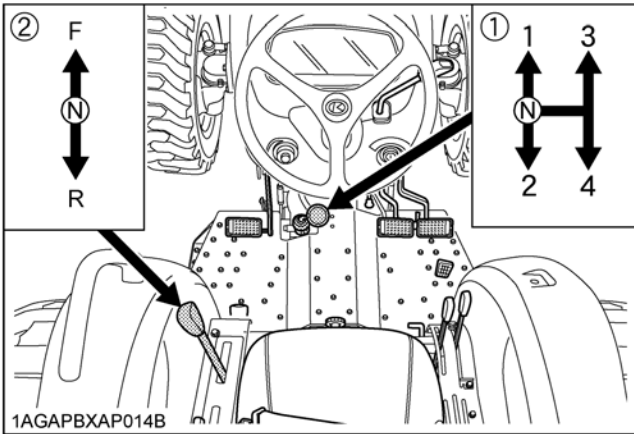

(1) Main gear shift lever

(2) Synchro-shuttle shift lever

(F) "FORWARD"

(N) "NEUTRAL POSITION"

(R) "REVERSE"

3. Make sure the cruise control lever is in "NEUTRAL" position.
Place the Speed control Pedal in "NEUTRAL" position.
Place the range gear shift lever in "NEUTRAL" position.

[HST Type]

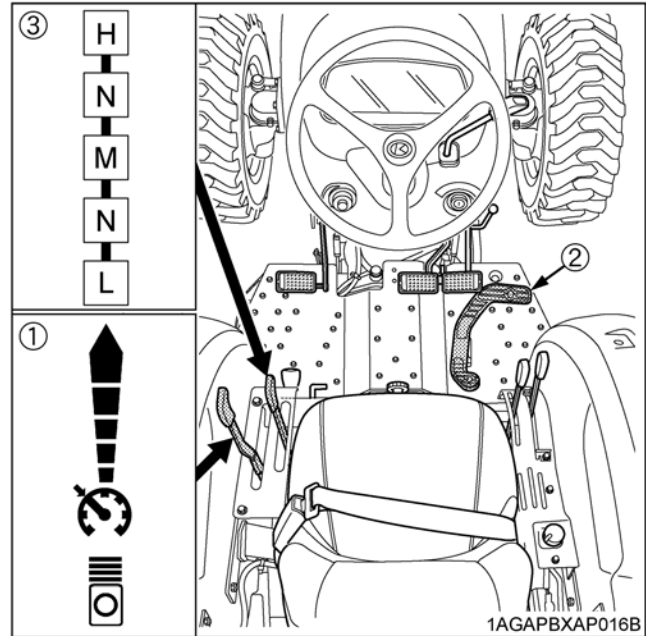

(1) Cruise control lever

(2) Speed control pedal

(3) Range gear shift lever

(N) "NEUTRAL POSITION"

○ "NEUTRAL POSITION"

NOTE :

- Depress the both brake pedals together, doing so the cruise control lever automatically returns to the off position.
- When removing the foot from speed control pedal, the pedal automatically returns to the neutral position.

4. Place the PTO clutch control switch in "OFF" position.

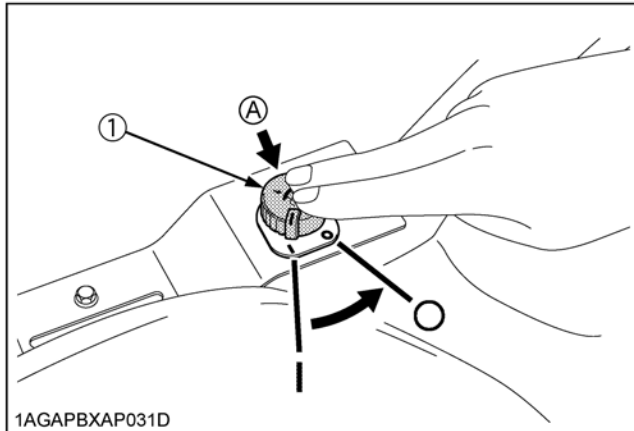

1AGAPBXAP031D

- (1) PTO clutch control switch
- ⏴ "ON" (Engaged)
 - "OFF" (Disengaged)
 - (A) "PUSH"

6. Set the throttle lever to about 1/2 way.

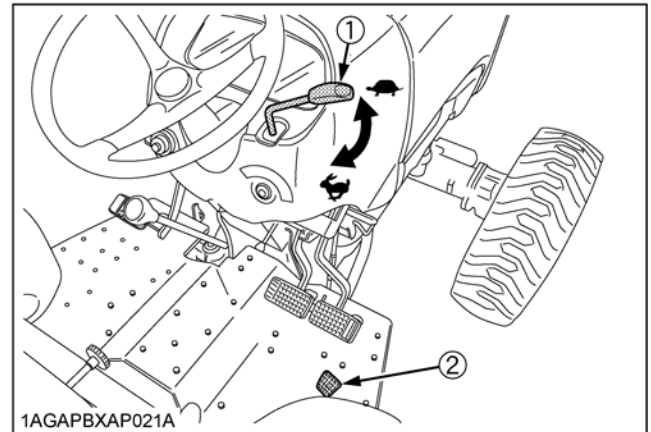

1AGAPBXAP021A

- (1) Hand throttle lever
- ➡ "INCREASE"
 - ⬅ "DECREASE"
- (2) Foot throttle
[except HST Type]

5. Place the hydraulic control levers in "LOWEST" position

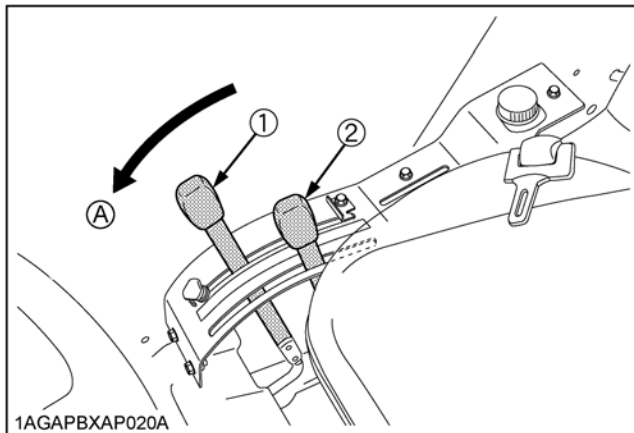

1AGAPBXAP020A

- (1) Position control lever
- (2) Draft control lever (if equipped)
- (A) "DOWN"

7. Insert the key into the key switch and turn it "ON".

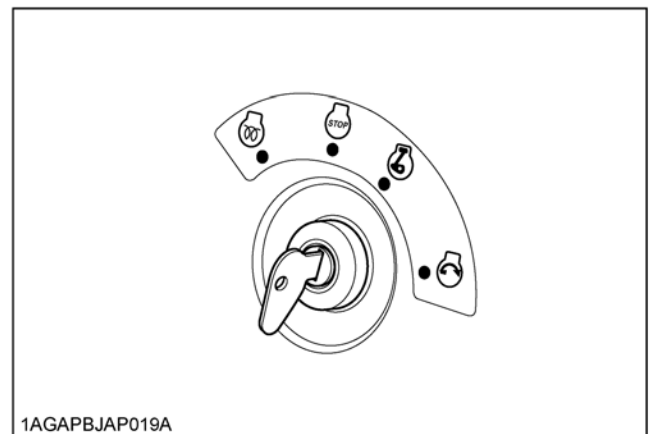

1AGAPBJAP019A

- ⏴ "PREHEAT"
- ⏴ "ON"
- ⏴ "OFF"
- ⏴ "START"

◆ **Check Warning lamps:**

When the key is turned "ON", lamps (1) (2) should come on. If trouble should occur at any location while the engine is running, the warning lamp corresponding to that location comes on.

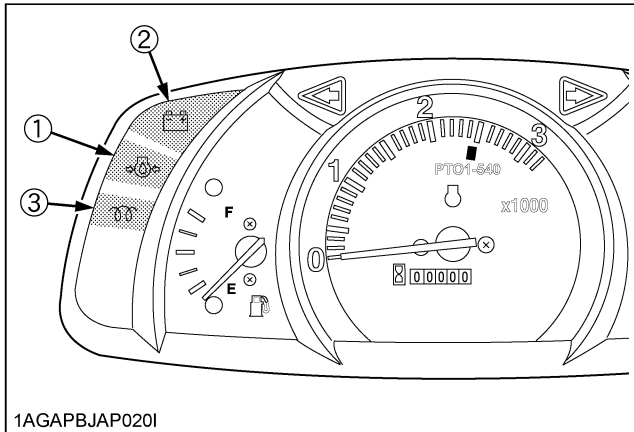

1AGAPBJAP020I

- (1) Engine oil pressure
- (2) Electrical charge
- (3) Glow plug indicator

IMPORTANT :

- Daily checks with the warning lamps only are not sufficient. Never fail to conduct physical daily checks carefully by referring to Daily Check section. (See "DAILY CHECK" in "PERIODIC SERVICE" section.)

8. Fully depress the clutch pedal.

9. Turn the key to the start position and the engine should start.

IMPORTANT:

[Manual Transmission Type]

- Because of the safety devices, the engine will not start except when the PTO clutch control switch is placed in the "OFF" position and shuttle shift lever is placed in the "NEUTRAL" position.

[HST Type]

- Because of the safety devices, the engine will not start except when the PTO clutch control switch is placed in the "OFF" position, the speed control pedal is placed in the "NEUTRAL" position and the clutch pedal is depressed.

10. Check to see that engine oil pressure and electrical charge lamps are "OFF".

If the lamp is still on, immediately stop the engine and determine the cause.

11. Release the clutch pedal.

COLD WEATHER STARTING

If the ambient temperature is below -5 °C (23 °F) and the engine is very cold, follow the procedure below after taking the step 1 through 8 in the previous pages.

9. Turn the key to "PREHEAT" and keep it there for ten seconds.

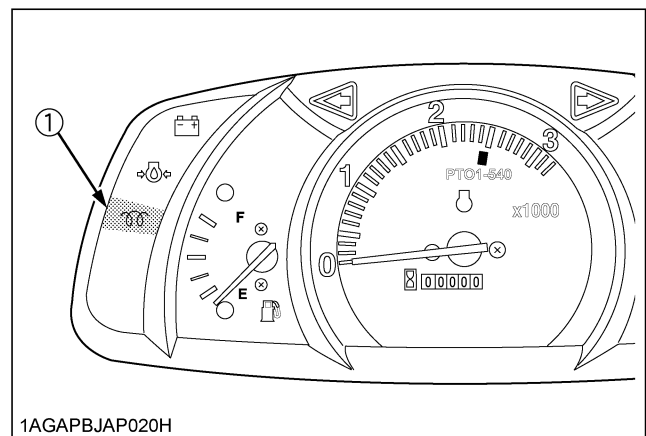

1AGAPBJAP020H

- (1) Glow plug indicator

10. Turn the key to the start position and the engine should start.

(If the engine fails to start after 10 seconds, turn off the key for 30 seconds. Then repeat steps (9) and (10). To protect the battery and the starter, make sure that the starter is not continuously turned for more than 10 seconds.)

■ Block Heater (if equipped)

A block heater is available as an option from your dealer. It will assist you in starting your tractor when the ambient temperature is below -20 °C (-4 °F).

STOPPING THE ENGINE

1. After slowing the engine to idle, turn the key to "OFF".
2. Remove the key.

NOTE :

- If key does not stop the engine, consult your local KUBOTA Dealer.

WARMING UP



CAUTION

To avoid personal injury:

- Be sure to set the parking brake during warm-up.
- Be sure to set all shift levers to the "NEUTRAL" positions and to place PTO clutch control switch in "OFF" position during warm-up.

For five minutes after engine start-up, allow engine to warm up without applying any load, this is to allow oil to reach every engine part. If load should be applied to the engine without this warm-up period, trouble such as seizure, breakage or premature wear may develop.

■ Warm-Up Transmission Oil in the Low Temperature Range

Hydraulic oil serves as transmission fluid. In cold weather, the oil may be cold with increased viscosity. This can cause delayed oil circulation or abnormally low hydraulic pressure for some time after engine start-up. This in turn can result in trouble in the hydraulic system. To prevent the above, observe the following instructions:

Warm up the engine at about 50% of rated rpm according to the table below:

Ambient temperature	Warm-up time requirement
Higher than -10 °C (14 °F)	Approx. 5 minutes
-15 to -10 °C (5 to 14 °F)	5 to 10 minutes
-20 to -15 °C (-4 to 5 °F)	10 to 20 minutes
Below -20 °C (-4 °F)	More than 20 minutes

IMPORTANT :

- Do not operate the tractor under full load condition until it is sufficiently warmed up.

JUMP STARTING



CAUTION

To avoid personal injury:

- Battery gases can explode. Keep cigarettes, sparks, and flames away from battery.
- If tractor battery is frozen, do not jump start engine.
- Do not connect other end of negative (-) jumper cable to negative (-) terminal of tractor battery.

When jump starting engine, follow the instructions below to safely start the engine.

1. Bring helper vehicle with a battery of the same voltage as disabled tractor within easy cable reach. "THE VEHICLES MUST NOT TOUCH".
2. Engage the parking brakes of both vehicles and put the shift levers in neutral. Shut both engines off.
3. Put on safety goggles and rubber gloves.
4. Ensure the vent caps are securely in place. (if equipped)
5. Cover vent holes with damp rags. Do not allow the rag to touch the battery terminals.
6. Attach the red clamp to the positive (red, (+) or pos.) terminal of the dead battery and clamp the other end of the same cable to the positive (red, (+) or pos.) terminal of the helper battery.
7. Clamp the other cable to the negative (black, (-) or neg.) terminal of the helper battery.
8. Clamp the other end to the engine block or frame of the disabled tractor as far from the dead battery as possible.
9. Start the helper vehicle and let its engine run for a few moments. Start the disabled tractor.
10. Disconnect the jumper cables in the exact reverse order of attachment. (Steps 8, 7 and 6).
11. Remove and discard the damp rags.

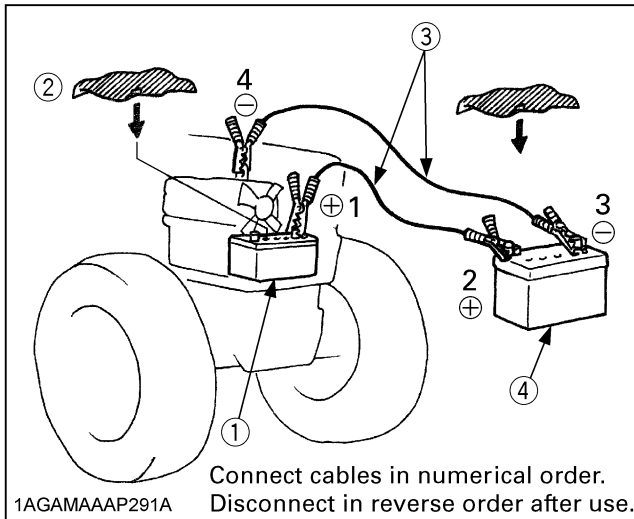

- (1) Dead battery
- (2) Lay a damp rag over the vent caps
- (3) Jumper cables
- (4) Helper battery

IMPORTANT :

- This machine has a 12 volt negative (-) ground starting system.
- Use only same voltage for jump starting.
- Use of a higher voltage source on tractor's electrical system could result in severe damage to tractor's electrical system.
Use only matching voltage source when "Jump starting" a low or dead battery condition.
- Do not operate the tractor with the battery cable disconnected from the battery.
- Do not operate the tractor without the battery mounted.
- Do not operate the tractor with the battery dead.
Charge the battery fully enough before operating the tractor.
Otherwise the tractor might malfunction.

OPERATING THE TRACTOR

OPERATING NEW TRACTOR

How a new tractor is handled and maintained determines the life of the tractor.

A new tractor just off the factory production line has been, of course, tested, but the various parts are not accustomed to each other, so care should be taken to operate the tractor for the first 50 hours at a slower speed and avoid excessive work or operation until the various parts become "broken-in". The manner in which the tractor is handled during the "breaking-in" period greatly affects the life of your tractor. Therefore, to obtain the maximum performance and the longest life of the tractor, it is very important to properly break-in your tractor. In handling a new tractor, the following precautions should be observed.

■ Do not Operate the Tractor at Full Speed for the First 50 Hours

- Do not start quickly nor apply the brakes suddenly.
- In winter, operate the tractor after fully warming up the engine.
- Do not run the engine at speeds faster than necessary.
- On rough roads, slow down to suitable speeds.
Do not operate the tractor at fast speed.

The above precautions are not limited only to new tractors, but to all tractors. But it should be especially observed in the case of new tractors.

■ Changing Lubricating Oil for New Tractors

The lubricating oil is especially important in the case of a new tractor. The various parts are not "broken-in" and are not accustomed to each other; small metal grit may develop during the operation of the tractor; and this may wear out or damage the parts. Therefore, care should be taken to change the lubricating oil a little earlier than would ordinarily be required.

For further details of change interval hours.
(See "MAINTENANCE" section.)

OPERATING FOLDABLE ROPS (if equipped)



CAUTION

To avoid personal injury:

- When raising or folding the ROPS, apply parking brake, stop the engine and remove the key.
Always perform function from a stable position at the rear of tractor.
- Fold the ROPS down only when absolutely necessary and fold it up and lock it again as soon as possible.
- Before proceeding to fold ROPS, check for any possible interference with installed implements and attachments.
If interference occurs, contact your KUBOTA Dealer.

■ To Fold the ROPS

1. Remove both set bolts.

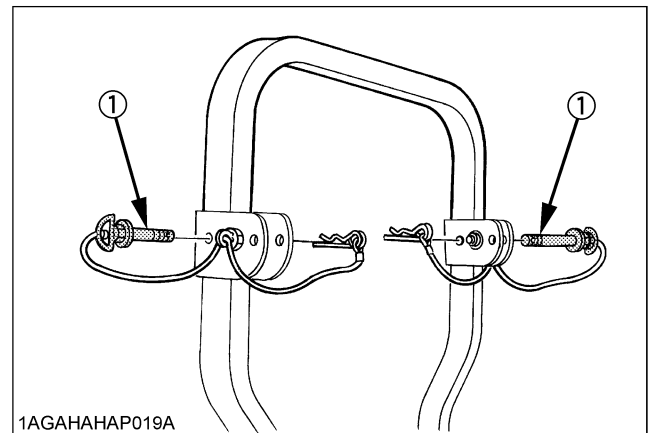

(1) Set bolt

2. Fold the ROPS.

CAUTION

To avoid personal injury:

- Hold the ROPS tightly with both hands and fold the ROPS slowly and carefully.

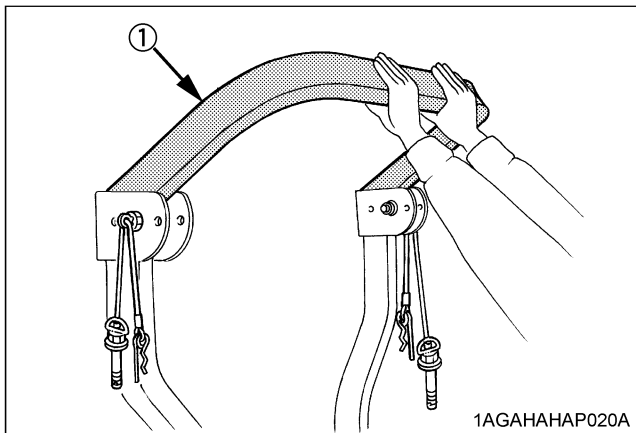

(1) ROPS

3. Align set bolt holes and insert both set bolts. Slightly tighten the set bolts and secure them with the hair pin cotters.

CAUTION

To avoid personal injury:

- Make sure that both set bolts are properly installed and secured with the hair pin cotters.

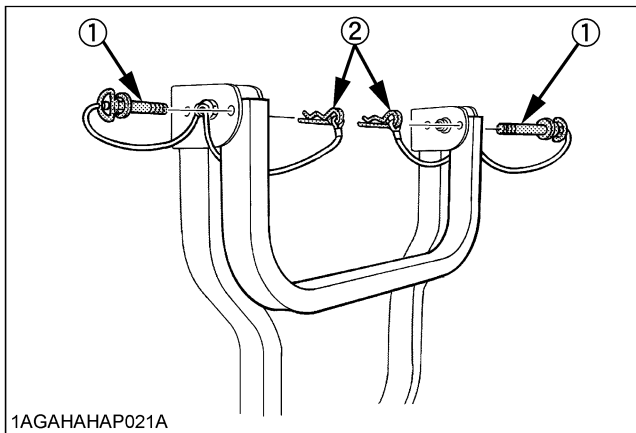

(1) Set bolt
(2) Hair pin cotter

To Raise the ROPS to Upright Position

1. Remove both hair pin cotters and set bolts.

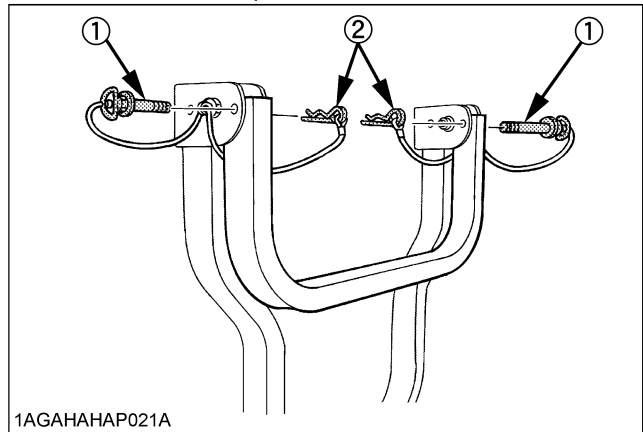

(1) Set bolt
(2) Hair pin cotter

2. Raise ROPS to the upright position.

CAUTION

To avoid personal injury:

- Raise the ROPS slowly and carefully.

3. Align set bolt holes, insert both set bolts. Slightly tighten the set bolts and secure them with the hair pin cotters.

CAUTION

To avoid personal injury:

- Make sure that both set bolts are properly installed as soon as the ROPS is in the upright position and secured with the hair pin cotters.

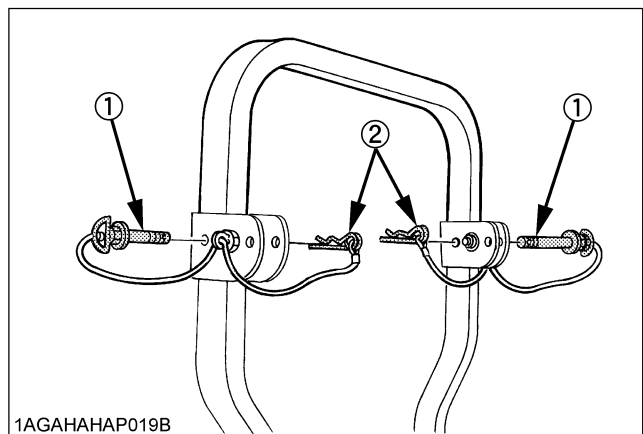

(1) Set bolt
(2) Hair pin cotter

■ Adjustment of Foldable ROPS

- Adjust free fall of the ROPS upper frame regularly.
- If you feel less friction in folding the ROPS, remove the cotter pin (1), tighten the nut (2) until you feel the right friction in the movement and then replace the cotter pin.

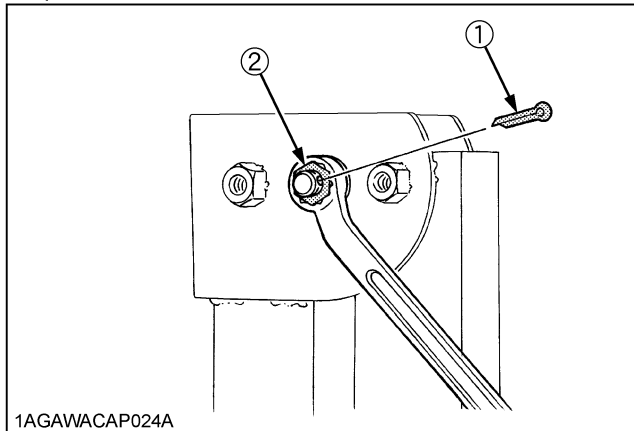

(1) Cotter pin
(2) Nut

STARTING

1. Adjusting the operator's position.

■ Operator's Seat

⚠ CAUTION

To avoid personal injury:

- Make adjustments to the seat only while the tractor is stopped.
- Make sure that the seat is completely secured after each adjustment.
- Do not allow any person other than the operator to ride on the tractor.

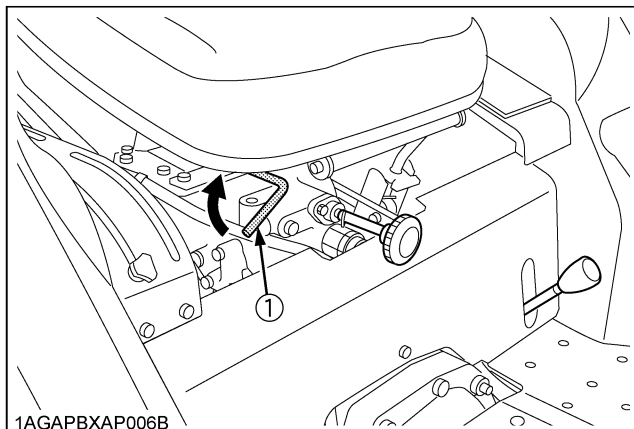

(1) Travel adjust lever

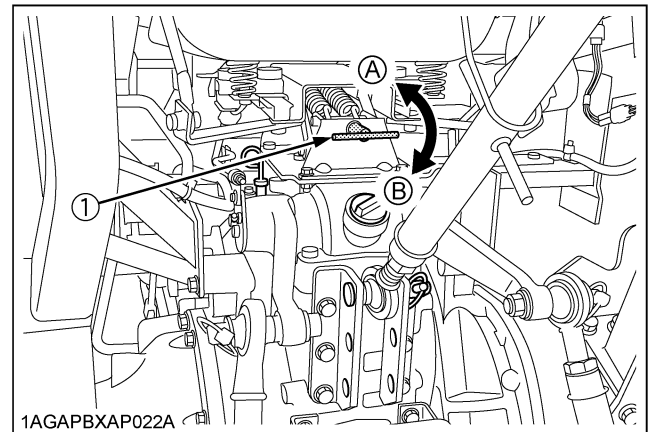

(1) Suspension adjust handle (A) To decrease tension
(B) To increase tension

◆ Travel adjustment

Pull up the travel adjust lever and slide the seat backward or forward, as required. The seat will lock in position when the lever is released.

◆ Suspension adjustment

Turn the suspension adjust handle to achieve the optimum suspension setting.

IMPORTANT :

- After adjusting the operator's seat, be sure to check to see that the seat is properly locked.
- Position the suspension adjust handle at the horizontal position.

■ Seat Belt



WARNING

To avoid personal injury:

- Always use the seat belt when any ROPS or CAB are installed.
- Do not use the seat belt if a foldable ROPS is down or there is no ROPS.

Adjust the seat belt for proper fit and connect the buckle. This seat belt is auto-locking retractable type.

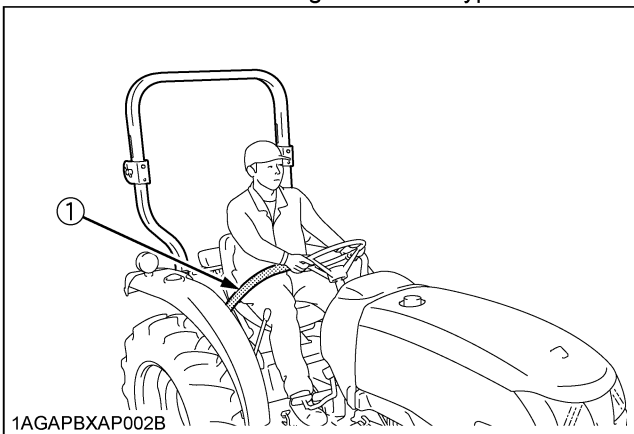

(1) Seat belt

2. Selecting light switch positions.

■ Head Light / Turn Signal / Hazard Light Switch

◆ Head Light Switch

Turn the light switch clockwise, and the following lights are activated on the switch position.

- (A) OFF.... Head lights OFF.
- (B) Head lights dimmed, low beam.
- (C) Head lights ON, high beam.

◆ Hazard Light Switch

When hazard light switch is pushed, the hazard lights flash along with the indicator on the instrument panel. Press the hazard light switch again to turn off the light.

◆ Turn Signal with Hazard Light

1. To indicate a right turn with the hazard lights already flashing (hazard on), turn the knob clockwise.
2. To indicate a left turn with the hazard lights already flashing, turn the knob counterclockwise.

3. When the left or right turn signal is activated in combination with the hazard lights, the indicated turning light will flash and the other will stay on.

◆ Turn Signal without Hazard light

1. To indicate a right turn without hazard lights (hazard off), turn the knob clockwise.
2. To indicate a left turn without hazard lights, turn the knob counterclockwise.
3. When the left or right turn signal is activated without the hazard lights, the indicated turning light will flash and the other will be on.

NOTE :

- Be sure to return switch to center position after turning.

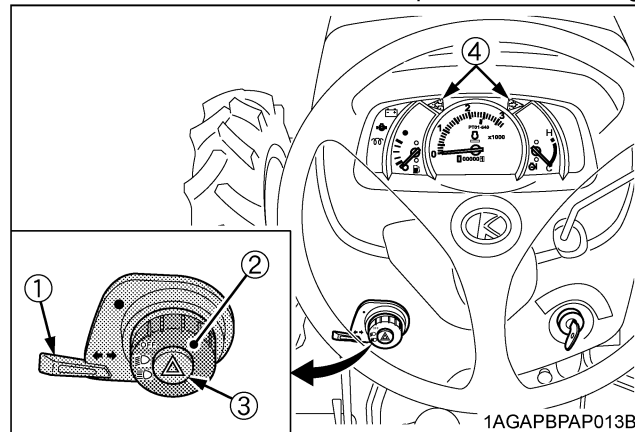

- (1) Turn signal light switch
- (2) Head light switch
- (3) Hazard light switch
- (4) Hazard / Turn signal indicator

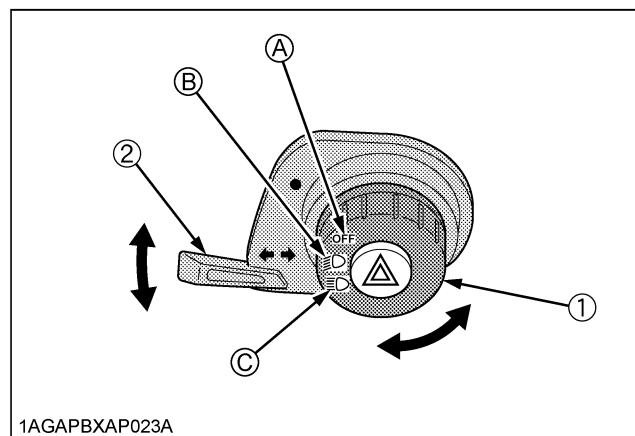

- (1) Head light switch
- (2) Turn signal light switch
- (A) "OFF"
- (B) "ON (LOW)"
- (C) "ON (HIGH)"

■ **Tractor Lights**

- (1) Head light
- (2) Turn signal / Hazard light
- (3) Rear turn signal / Hazard light
- (4) Tail light

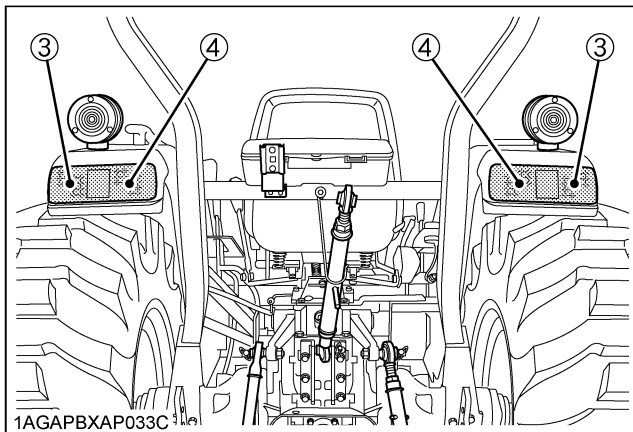
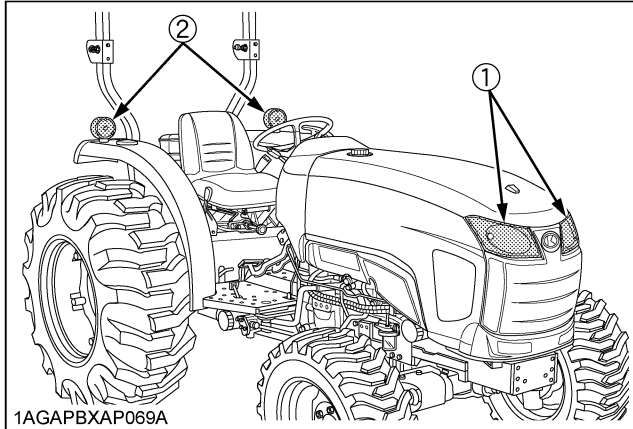

3. **Checking the brake pedal.**

■ **Brake Pedals (Right and Left)**



WARNING

To avoid personal injury:

- Be sure to interlock the right and left pedals. Applying only one rear wheel brake at high speeds could cause the tractor to swerve or roll-over.
- Be sure brake pedals have equal adjustment when using locked together. Incorrect or unequal brake pedal adjustment can cause the tractor to swerve or roll-over.



CAUTION

To avoid personal injury:

- Do not make sudden braking. An accident may occur such as by heavy towed load shifting forward or loss of control.
- To avoid skidding and loss of steering control when driving on icy, wet, or loose surfaces, make sure the tractor is correctly ballasted, operated at reduced speed, operated with front wheel drive engaged (if equipped).
- The braking characteristics are different between two and four wheel drive. Be aware of the difference and use carefully.

1. Before operating the tractor on the road or before applying the parking brake, be sure to interlock the right and left pedals as illustrated below.
2. Use individual brakes to assist in making sharp turns at slow speeds (Field Operation Only). Disengage the brake pedal lock and depress only one brake pedal.
3. Be sure brake pedals have equal adjustment when using locked together.

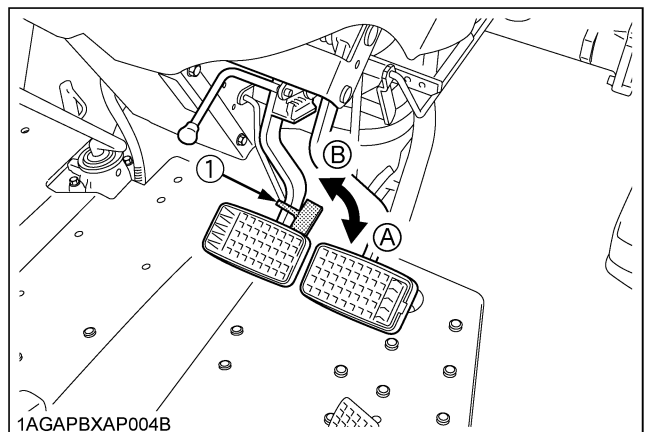

(1) Brake pedal lock

(A) "LOCK"

(B) "RELEASE"

4. Raise the implement.
(See "HYDRAULIC UNIT" section.)

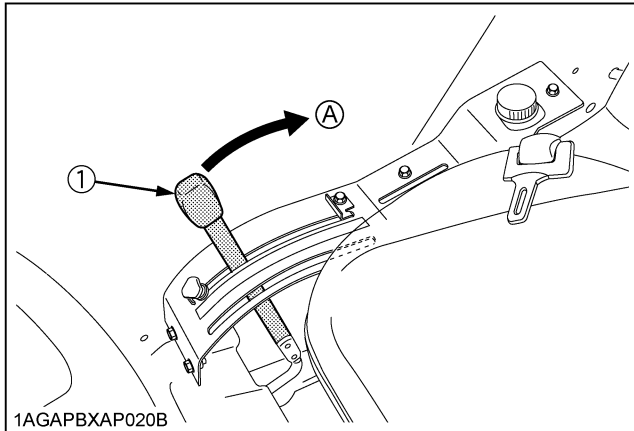

(1) Position control lever (A) "UP"

5. Depress the clutch pedal.

■ Clutch Pedal



CAUTION

To avoid personal injury:

- Sudden release of the clutch may cause the tractor to lunge in an unexpected manner.

The clutch is disengaged when the clutch pedal is fully pressed down.

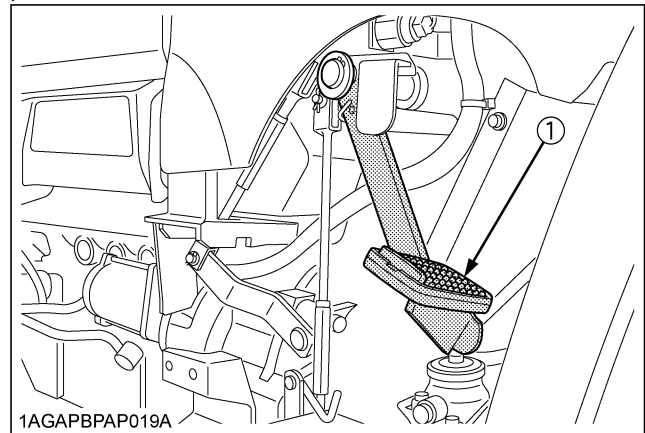

(1) Clutch pedal

IMPORTANT :

To help prevent premature clutch wear:

- The clutch pedal must be quickly disengaged and be slowly engaged.
- Avoid operating the tractor with your foot resting on the clutch pedal.
- Select proper gear and engine speed depending on the type of job.

6. Selecting the Travel Speed.

[Manual Transmission Type]

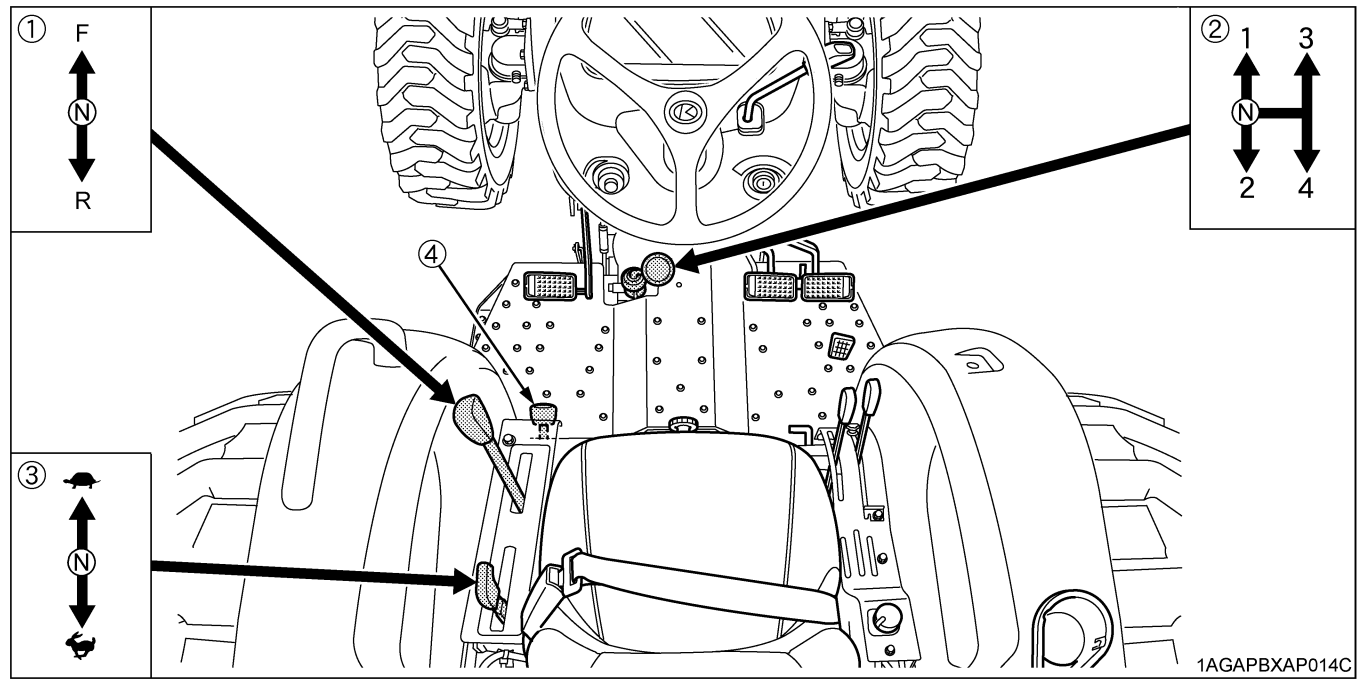

- (1) Synchro-shuttle shift lever
 (2) Main gear shift lever
 (3) Range gear shift lever
 (4) Front wheel drive lever

- (F) "FORWARD"
 (N) "NEUTRAL POSITION"
 (R) "REVERSE"

- ☰ "LOW"
 ☷ "HIGH"

■ Main Gear Shift Lever & Range Gear Shift Lever

The main gear shift and the range gear shift can only be shifted when tractor is completely stopped and clutch is depressed.

IMPORTANT :

- To change speeds, press the clutch pedal completely down and stop the tractor before attempting to proceed with speed change.

■ Synchro-Shuttle Shift Lever

Shift the shuttle shift lever forward to obtain forward speeds and shift back to obtain reverse speeds. When changing the shuttle shift lever, depress the clutch pedal and stop the tractor before shifting.

IMPORTANT :

- The synchro-shuttle shift lever may be shifted while the tractor is moving slowly and the clutch is depressed, but sudden gear shifting may cause transmission damage.

NOTE :

- When you stand up from the seat with the shuttle lever at "FORWARD" or "BACKWARD", the engine will stop regardless of whether the tractor is moving or not. This is because the tractor is equipped with Operator Presence Control system (OPC).

HST

MT

Front Wheel Drive Lever

[4WD]



CAUTION

To avoid personal injury:

- Do not engage the front wheel drive when traveling at road speed.
- When driving on icy, wet, or loose surfaces, make sure the tractor is correctly ballasted to avoid skidding and loss of steering control. Operate at reduced speed and engage front wheel drive.
- An accident may occur if the tractor is suddenly braked, such as by heavy towed loads shifting forward or loss of control.
- The braking characteristics are different between two and four wheel drive. Be aware of the difference and use carefully.

Use the lever to engage the front wheels with the tractor stopped. Shift the lever to "ON" to engage the front wheel drive.

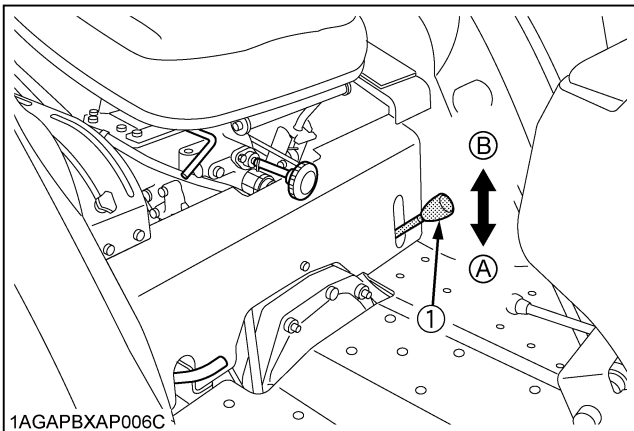

(1) Front wheel drive lever (A) "ON" (B) "OFF"

IMPORTANT :

- Depress the clutch pedal before engaging the front wheel drive lever.
- If the front wheel drive lever is difficult to set to OFF, stop the tractor, turn the steering wheel and move the lever.
- Tires will wear quickly if front wheel drive is engaged on paved roads.

◆ Front wheel drive is effective for the following jobs:

1. When greater pulling force is needed, such as working in a wet field, when pulling a trailer, or when working with a front-end loader.
2. When working in sandy soil.
3. When working on a hard soil where a rotary tiller might push the tractor forward.

4. For increased braking at reduced speed.

7. Accelerate the engine.

Hand Throttle Lever

Pulling the throttle lever back increases engine speed, and pushing it forward decreases engine speed.

Foot Throttle

Use the foot throttle when traveling on the road. Press down on it for higher speed. The foot throttle is interlocked with the hand throttle lever; when using the foot throttle, keep the hand throttle lever in low idling position.

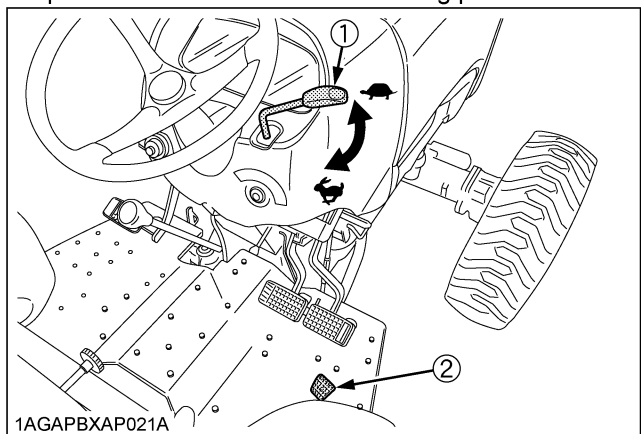

(1) Hand throttle lever (2) Foot throttle
 ↖ "INCREASE"
 ↗ "DECREASE"

8. Unlock the parking brake and slowly release the clutch.

Parking Brake

To release the parking brake, depress the brake pedals again.

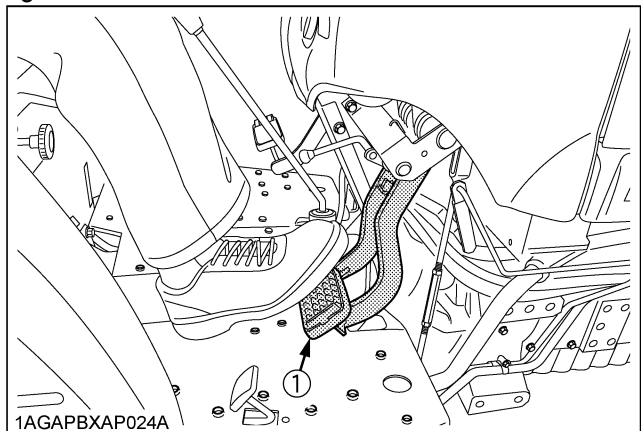

(1) Brake pedals

6. Selecting the Travel Speed.

[HST Type]

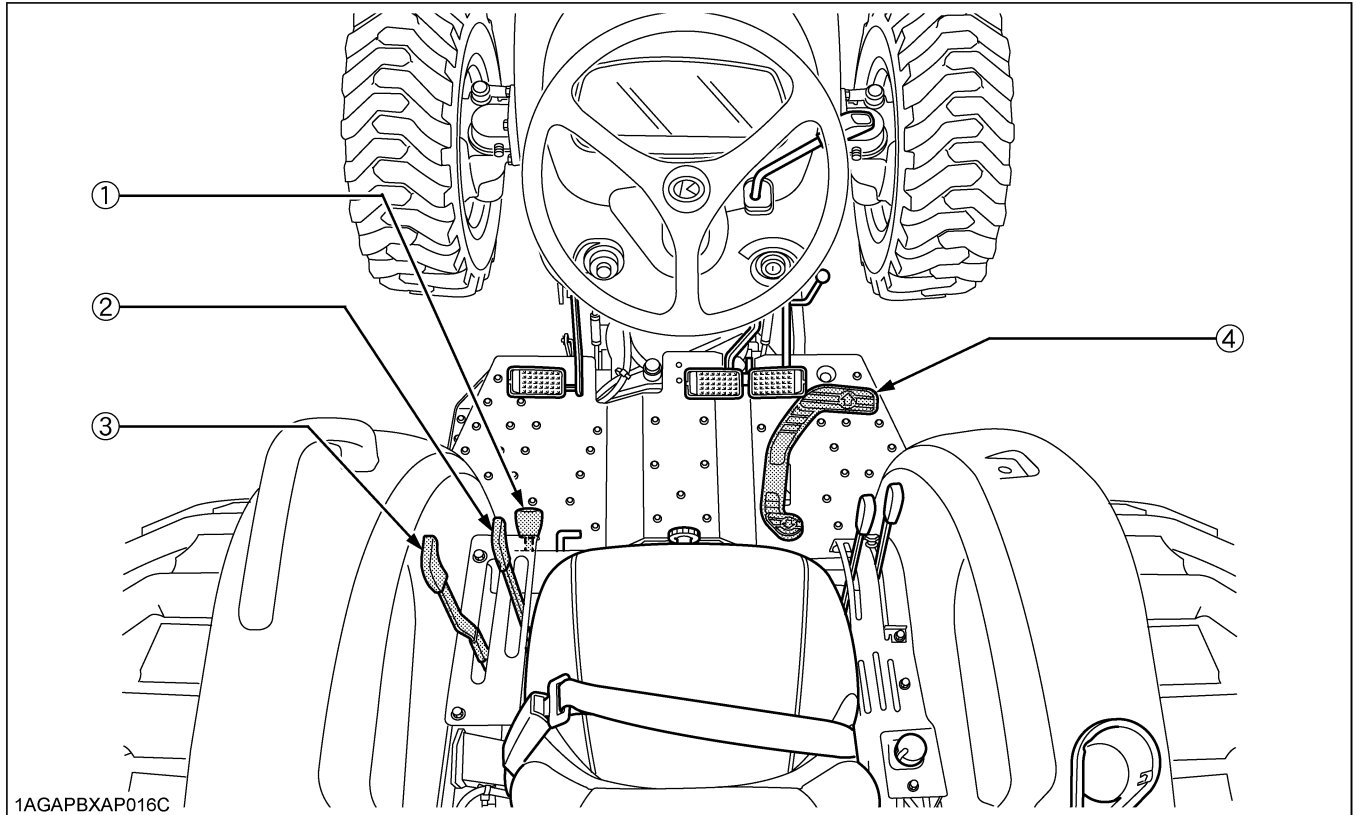

1AGAPBXAP016C

- (1) Front wheel drive lever
- (2) Range gear shift lever
- (3) Cruise control lever
- (4) Speed control pedal

■ Range Gear Shift Lever (L-M-H)

The range gear shift can only be shifted when the tractor is completely stopped and the speed control pedal is in the neutral position.

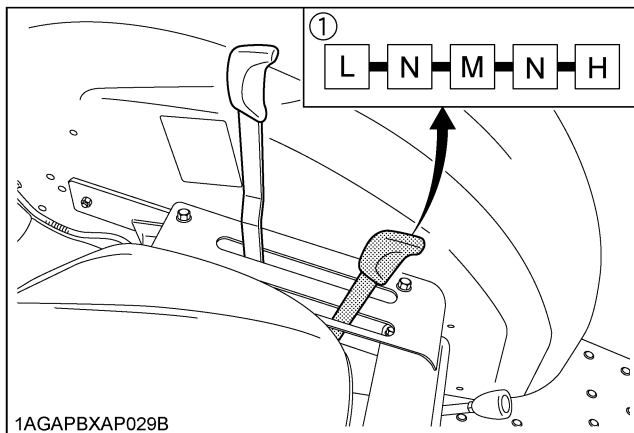

1AGAPBXAP029B

- (1) Range gear shift lever (L-M-H)
- (H) "HIGH"
- (M) "MIDDLE"
- (L) "LOW"
- (N) "NEUTRAL POSITION"

IMPORTANT:

To avoid transmission and shift linkage damage when shifting:

- Completely stop the tractor using the brake pedals.
- Do not force the range gear shift lever.
- If it is difficult to shift the lever into L, M, or H from neutral position:

On slopes be sure to set the parking brake before starting the procedure.

- (1) Slightly depress the speed control pedal to rotate the gears inside of the transmission.
- (2) Release the speed control pedal to the neutral position.
- (3) Depress the clutch pedal, wait for a moment and then shift the lever.

■ Front Wheel Drive Lever

⚠ CAUTION

To avoid personal injury:

- Do not engage the front wheel drive when traveling at road speed.
- When driving on icy, wet or loose surfaces, make sure the tractor is correctly ballasted to avoid skidding and loss of steering control. Operate at reduced speed and engage front wheel drive.
- An accident may occur if the tractor is suddenly braked, such as by heavy towed loads shifting forward or loss of control.
- The braking characteristics are different between two and four wheel drive. Be aware of the difference and use carefully.

Use the lever to engage the front wheels with the tractor stopped. Shift the lever to "ON" to engage the front wheel drive.

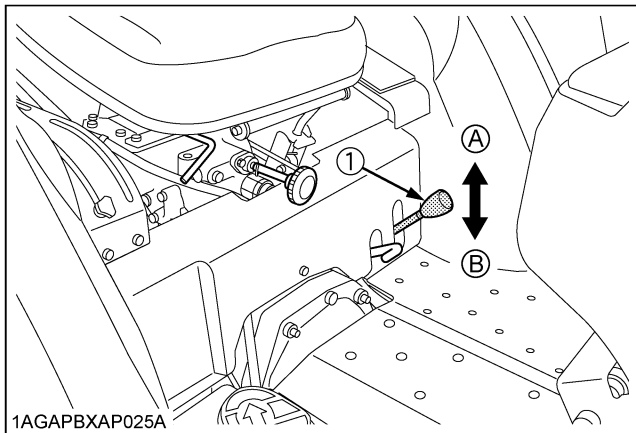

(1) Front wheel drive lever (A) "ON"
(B) "OFF"

IMPORTANT :

- Depress the clutch pedal before engaging the front wheel drive lever.
- If the front wheel drive lever is difficult to set to OFF, stop the tractor, turn the steering wheel and move the lever.
- Tires will wear quickly if front wheel drive is engaged on paved roads.

◆ Front wheel drive is effective for the following jobs:

1. When greater pulling force is needed, such as working in a wet field, when pulling a trailer, or when working with a front-end loader.
2. When working in sandy soil.
3. When working on a hard soil where a rotary tiller might push the tractor forward.
4. For increased braking at reduced speed.

7. Accelerate the engine.

■ Hand Throttle Lever

Pulling the throttle lever back increases engine speed, and pushing it forward decreases engine speed.

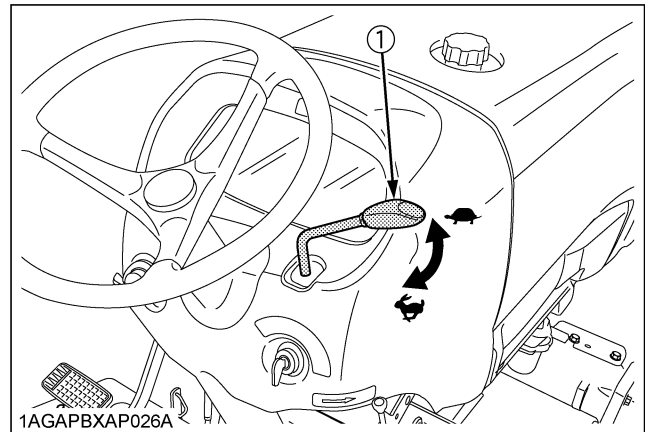

(1) Hand throttle lever
 ↖ "INCREASE"
 ↗ "DECREASE"

8. Unlock the parking brake and slowly release the clutch.

■ Parking Brake

To release the parking brake, depress the brake pedals again.

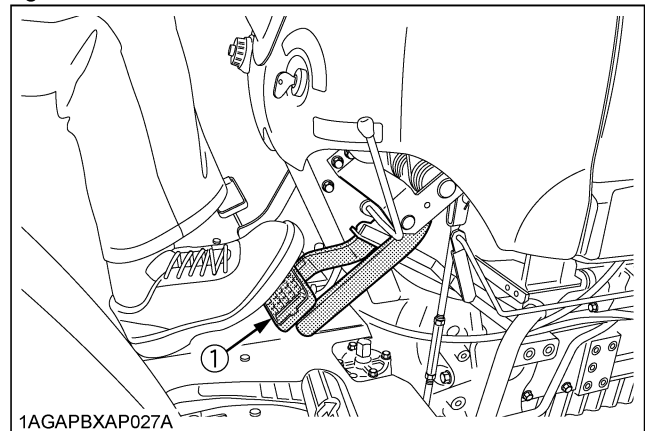

(1) Brake pedals

9. Depress the Speed Control Pedal. [HST Type]

■ Speed Control Pedal



WARNING

To avoid personal injury:

- Do not operate if tractor moves on level ground with foot off of Speed Control Pedal.
- Consult your local KUBOTA Dealer.

Forward Pedal

Depress the speed control pedal with the toe of your right foot to move forward.

Reverse Pedal

Depress the speed control pedal with the heel of your right foot to move backward.

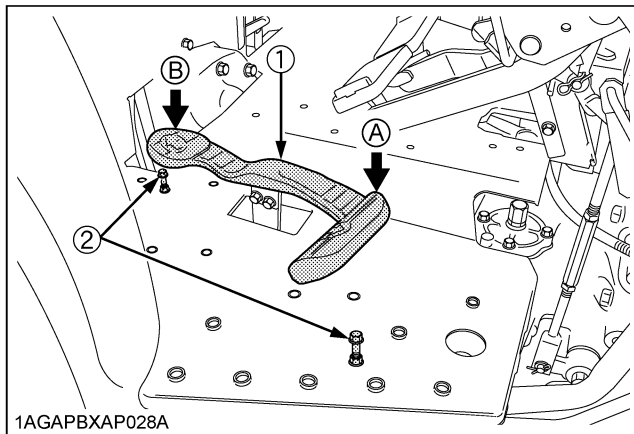

(1) Speed control Pedal
(2) Stopper bolt

(A) "FORWARD"
(B) "REVERSE"

IMPORTANT :

- To prevent serious damage to the HST, do not adjust the stopper bolts.

NOTE :

- When you stand up from the seat with the speed control pedal stepped on or the cruise control lever engaged (ON), the engine will stop regardless of whether the tractor is moving or not. This is because the tractor is equipped with Operator Presence Control system (OPC).

■ Cruise Control Lever



CAUTION

To avoid personal injury:

- Pull the cruise control lever completely to the rear before starting the engine.
- Do not use the cruise control when driving on the road.
- Be sure to connect both the left and the right brakes to release the cruise control. The speed cruise control won't be released with single brake activation.

Cruise control is designed for tractor operating efficiency and operator comfort. This device will provide a constant forward operating speed by mechanically holding the cruise control lever at the selected position.

◆ To engage Cruise Control Device

1. The proper forward speed will be maintained if you apply the cruise control lever at any position.
2. To operate faster than the set speed, depress the speed control pedal further down in this condition. The set speed will be resumed if you release the pedal.

◆ To disengage Cruise Control Device

- Move the lever all the way back and then to "NEUTRAL" position to release the cruise control.
- Depress both brake pedals.

NOTE :

- Cruise control will be disengaged automatically when both brake pedals are depressed.
- The cruise control device does not disengage when the individual right or left brake is applied.
- Cruise control device will not operate in reverse.
- Preferably set the cruise control lever, while holding down the speed control pedal. This makes the setting smoother.

- When releasing the cruise mode, be sure to return the cruise control lever fully backward.

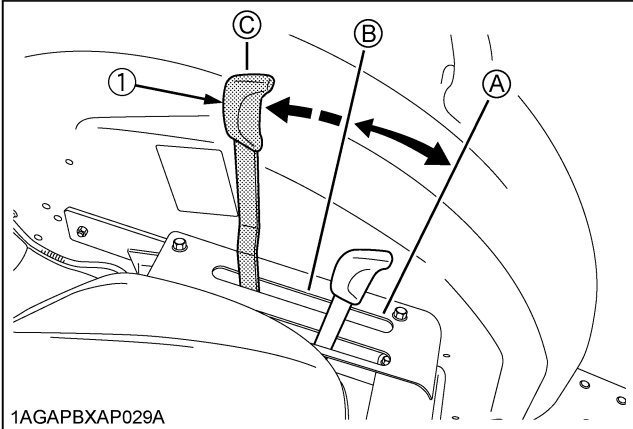

1AGAPBXAP029A

- (1) Cruise control lever
 (A) "INCREASE"
 (B) "DECREASE"
 (C) "NEUTRAL"

NOTE :

- When you stand up from the seat with the speed control pedal stepped on or the cruise control lever engaged (ON), the engine will stop regardless of whether the tractor is moving or not. This is because the tractor is equipped with Operator Presence Control system (OPC).

STOPPING

■ Stopping

1. Slow down the engine.
2. Step on the clutch and brake pedal.
3. After the tractor has stopped, disengage the PTO, lower the implement to the ground, shift the transmission to neutral, release the clutch pedal, and set the parking brake.

CHECK DURING DRIVING

■ Immediately Stop the Engine if:

- The engine suddenly slows down or accelerates,
- Unusual noises are suddenly heard,
- Exhaust fumes suddenly become very dark,

■ Easy Checker(TM)

If the indicators in the Easy Checker(TM) come on during operation, immediately stop the engine, and find the cause as shown below.

Never operate the tractor while Easy Checker(TM) lamp is on.

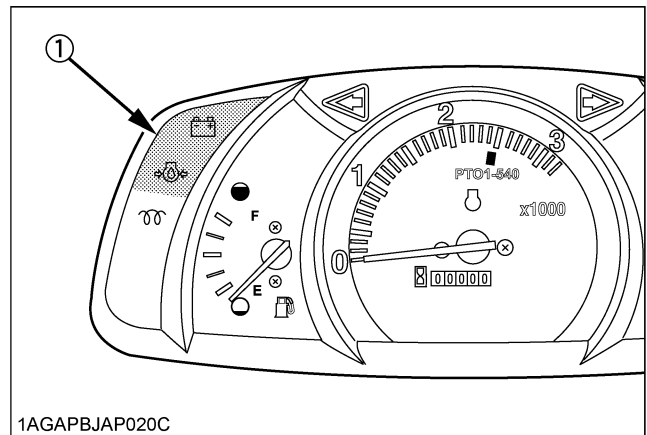

1AGAPBJAP020C

(1) Easy checker(TM)

 Engine oil pressure

If the oil pressure in the engine goes below the prescribed level, the indicator in the Easy Checker(TM) will come on. If this should happen during operation, and it does not go off when the engine is accelerated to more than 1000 rpm, check level of engine oil. (See "Checking Engine Oil Level" in "DAILY CHECK" in "PERIODIC SERVICE" section.)

 Electrical charge

If the alternator is not charging the battery, the indicator in the Easy Checker(TM) will come on. If this should happen during operation, check the electrical charging system or consult your local KUBOTA Dealer.

NOTE :

- For checking and servicing of your tractor, consult your local KUBOTA Dealer for instructions.

Fuel Gauge

When the key switch is on, the fuel gauge indicates the fuel level.

Be careful not to empty the fuel tank. Otherwise air may enter the fuel system.

Should this happen, the system should be bled. (See "Bleeding Fuel System" in "SERVICE AS REQUIRED" in "PERIODIC SERVICE" section.)

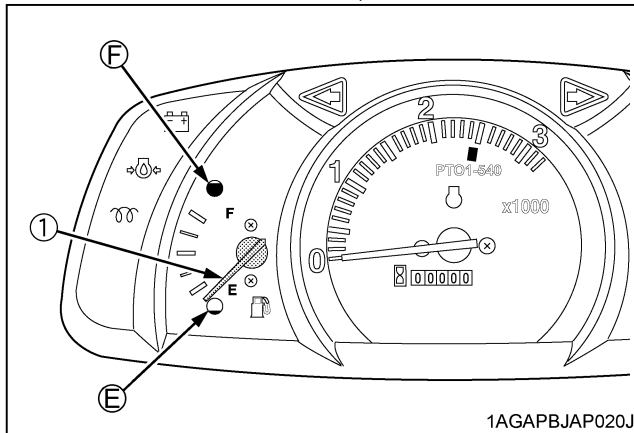

(1) Fuel gauge (E) "EMPTY"
(F) "FULL"

Coolant Temperature Gauge



CAUTION

To avoid personal injury:

- Do not remove radiator cap until coolant temperature is well below its boiling point. Then loosen cap slightly to the stop to relieve any pressure before removing cap completely.

- With the key switch at "ON", this gauge indicates the temperature of the coolant. "C" for "cold" and "H" for "hot".
- If the indicator reaches the red zone position, engine coolant is overheated. Check the tractor by referring to "TROUBLESHOOTING" section.

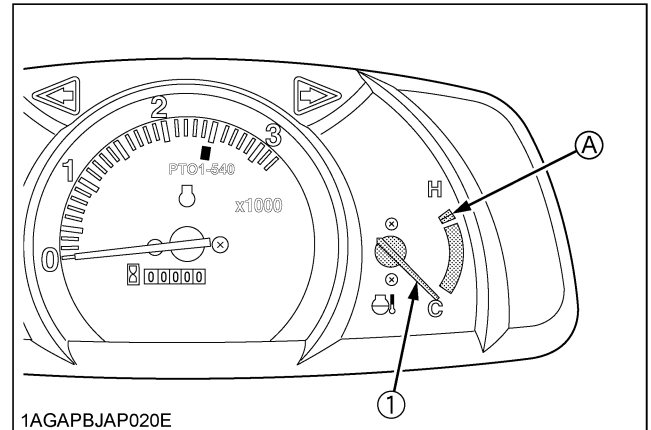

(1) Coolant temperature gauge (A) "RED ZONE"

Hourmeter/Tachometer

This meter gives readings for engine speed, PTO shaft speed and the hours the tractor has been operated.

- The tachometer indicates the engine speed and the 540 PTO shaft speed location on the dial.
- The hourmeter indicates in five digits the hours the tractor has been used; the last digit indicates 1/10 of an hour.

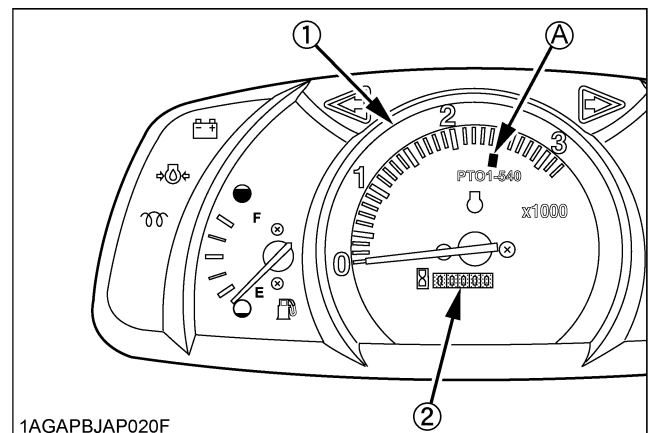

(1) Engine revolution (A) PTO : 540rpm
(2) Hours used

HST

MT

PARKING

■ Parking [Manual Transmission Type]

CAUTION

- To avoid personal injury:
BEFORE DISMOUNTING TRACTOR
- ALWAYS SET PARKING BRAKE AND LOWER ALL IMPLEMENTS TO THE GROUND.
 - STOP THE ENGINE AND REMOVE THE KEY.

1. When parking, be sure to set the parking brake.
To set the parking brake;
 - (1) Interlock the brake pedals.
 - (2) Depress the brake pedals.
 - (3) Latch the brake pedals with the parking brake lever.

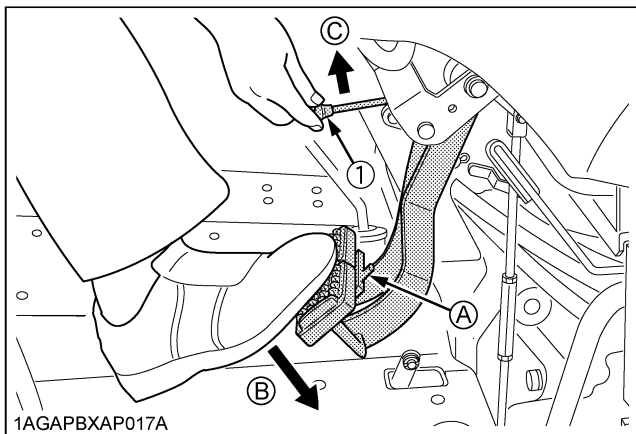

(1) Parking brake lever (A) Interlock the brake pedals
(B) "DEPRESS"
(C) "PULL"

IMPORTANT :

- To prevent damage to the parking brake lever, make sure that brake pedals are fully depressed before pulling the parking brake lever.
2. Before getting off the tractor, disengage the PTO, lower all implements to the ground, place all control levers in their neutral positions, set the parking brake, stop the engine and remove the key.
 3. If it is necessary to park on an incline, be sure to chock the wheels to prevent accidental rolling of the machine.

■ Parking [HST Type]

CAUTION

- To avoid personal injury:
BEFORE DISMOUNTING TRACTOR
- ALWAYS SET PARKING BRAKE AND LOWER ALL IMPLEMENTS TO THE GROUND.
Leaving transmission in gear with the engine stopped will not prevent tractor with HST transmission from rolling.
 - STOP THE ENGINE AND REMOVE THE KEY.

1. When parking, be sure to set the parking brake.
To set the parking brake;
 - (1) Interlock the brake pedals.
 - (2) Depress the brake pedals.
 - (3) Latch the brake pedals with the parking brake lever.

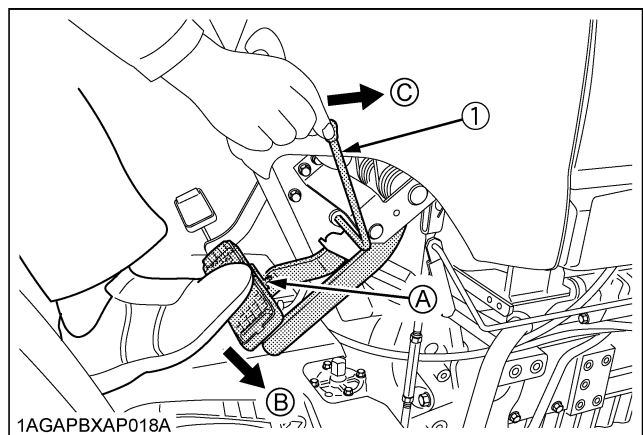

(1) Parking brake lever (A) Interlock the brake pedals
(B) "DEPRESS"
(C) "PUSH"

IMPORTANT :

- To prevent damage to the parking brake lever, make sure that brake pedals are fully depressed before pushing the parking brake lever.
2. Before getting off the tractor, disengage the PTO, lower all implements to the ground, place all control levers in their neutral positions, set the parking brake, stop the engine and remove the key.
 3. If it is necessary to park on an incline, be sure to chock the wheels to prevent accidental rolling of the machine.

OPERATING TECHNIQUES

■ Differential Lock



WARNING

To avoid personal injury due to loss of steering control:

- Do not operate the tractor at high speed with differential lock engaged.
- Do not attempt to turn with the differential lock engaged.
- Be sure to release the differential lock before making a turn in field conditions.

If one of the rear wheels should slip, step on the differential lock pedal. Both wheels will turn together, then reduce slippage.

Differential lock is maintained only while the pedal is depressed.

[Manual Transmission Type]

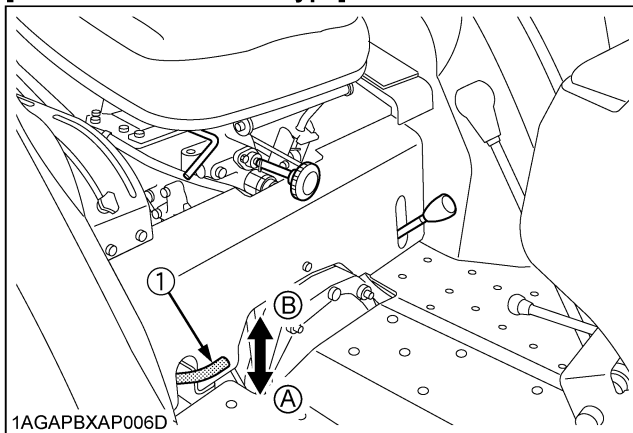

[HST Type]

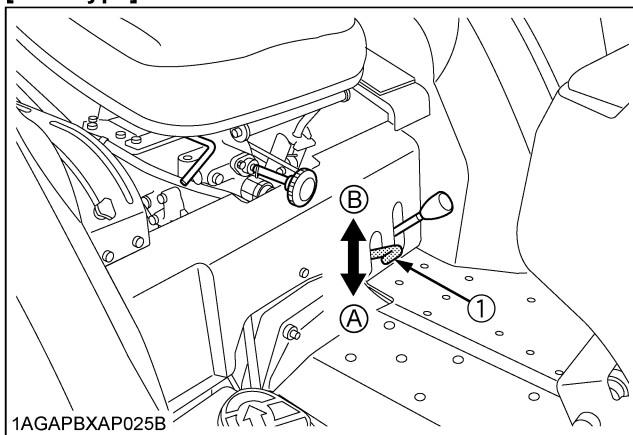

(1) Differential lock pedal

(A) Press to "ENGAGE"

(B) Release to "DISENGAGE"

IMPORTANT :

- When using the differential lock, always slow the engine down.
- To prevent damage to power train, do not engage differential lock when one wheel is spinning and the other is completely stopped.
- If the differential lock cannot be released, step lightly on the brake pedals alternately.

■ Operating the Tractor on a Road



CAUTION

To avoid personal injury:

- To help assure straight line stops when driving at transport speeds, lock the brake pedals together. Uneven braking at road speeds could cause the tractor to roll-over.
- When traveling on road with 3-point hitch mounted implement attached, be sure to have sufficient front weight on the tractor to maintain steering ability.

Be sure SMV emblem and warning lamps are clean and visible. If towed or rear-mounted equipment obstructs these safety devices, install SMV emblem and warning lamps on equipment.

Consult your local KUBOTA Dealer for further details.

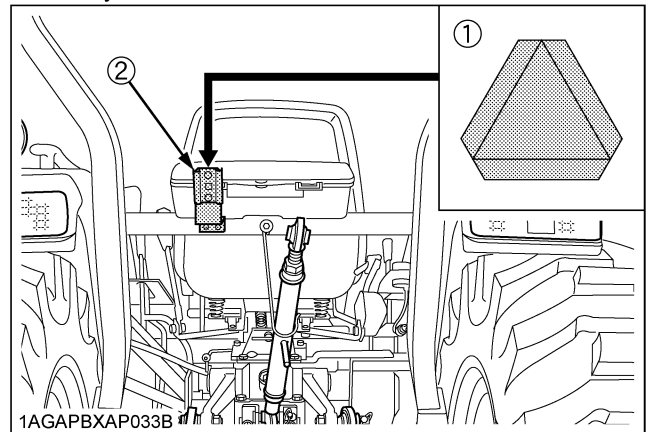

(1) SMV emblem

(2) Bracket

■ Operating on Slopes and Rough Terrain

CAUTION

To avoid personal injury:

- Always back up when going up a steep slope. Driving forward could cause the tractor to tip over backward. Stay off hills and slopes too steep for safe operation.
- Avoid changing gears when climbing or descending a slope.
- If operating on a slope, never disengage the clutch or shift levers to neutral. Doing so could cause loss of control.
- Do not drive the tractor close to the edges of ditches or banks which may collapse under the weight of the tractor. Especially when the ground is loose or wet.

1. Be sure wheel tread is adjusted to provide maximum stability.
(See "WHEEL ADJUSTMENT" in "TIRES, WHEELS AND BALLAST" section.)
2. Slow down for slopes, rough ground, or sharp turns, especially when transporting heavy, rear mounted equipment.
3. Before descending a slope, shift to a gear low enough to control speed without using brakes.

■ Directions for Use of Power Steering

1. Power steering is activated only while the engine is running. Slow engine speeds make the steering a little heavier. While the engine is stopped, the tractor functions in the same manner as tractors without power steering.
2. When the steering wheel is turned all the way to the stop, the relief valve is activated. Do not hold the steering wheel in this position for a long period of time.
3. Avoid turning the steering wheel while the tractor is stopped, or tires may wear out sooner.
4. The power steering mechanism makes the steering easier. Be careful when driving on a road at high speeds.

■ Electrical Outlet

A electrical outlet is supplied for use with implement.

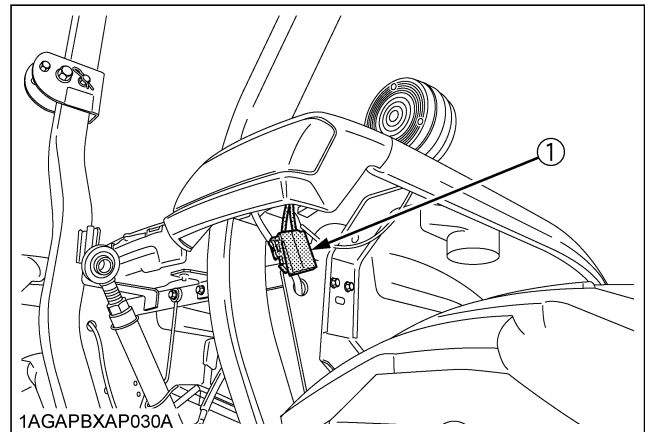

(1) Accessory electrical outlet (5 A)

PTO

PTO OPERATION



CAUTION

To avoid personal injury:

- Disengage PTO, stop engine, and allow all rotating components to come to a complete stop before connecting, disconnecting, adjusting, or cleaning any PTO driven equipment.

■ PTO Clutch Control Switch

1. The tractor has a 540 rpm speed position and 6-spline shaft.
2. The PTO clutch control switch engages or disengages the PTO clutch which gives the PTO independent control.

Turn the switch to "ON" to engage the PTO clutch. Turn the switch to "OFF" to disengage the PTO clutch.

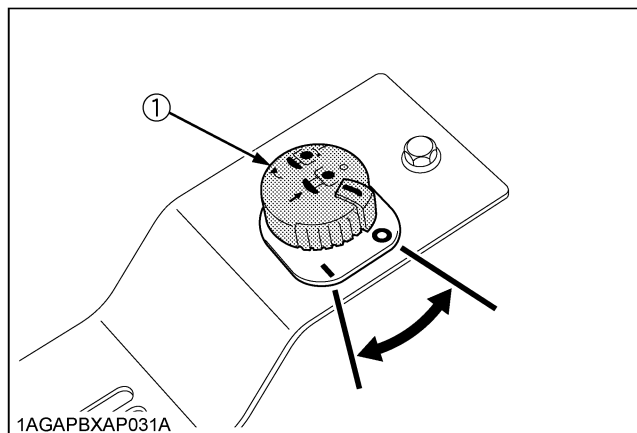

(1) PTO clutch control switch | "ON" ○ "OFF"

◆ PTO Clutch Control Switch

To turn ON

While pushing the switch, turn clockwise to the " | " position and release your hand. (In the ON position, switch slightly rises itself.)

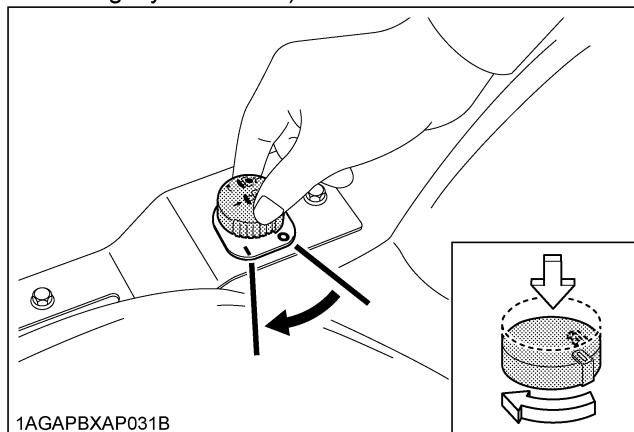

To Turn OFF

Tap on top of the switch, and the switch will return to the OFF position.

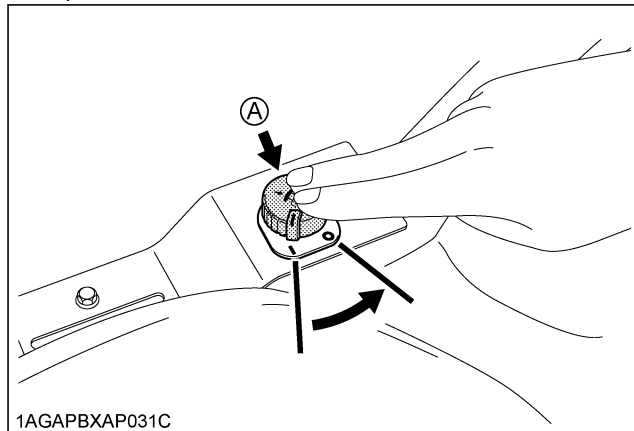

(A) "PUSH"

IMPORTANT :

- To avoid shock loads to the PTO, reduce engine speed when engaging the PTO, then open the throttle to the recommended speed.
- To avoid damage of PTO clutch and implement, proper warm up is strongly recommended in cold weather.
Do not continuously turn the PTO clutch control switch.

NOTE :

- There is a PTO-1 540 rpm indicated mark on the tachometer board.

- Tractor engine will not start if the PTO clutch control switch is in the engaged "ON" position.

■ Stationary PTO

To park the tractor and use the PTO system (for chipper or pump, for example), start the PTO system in the following steps.

1. Apply the parking brakes and place blocks at the tires.
2. Make sure the shift levers are at NEUTRAL, and start the engine.
3. Tilt the operator's seat forward.
4. Set the PTO clutch control switch to engage "ON".

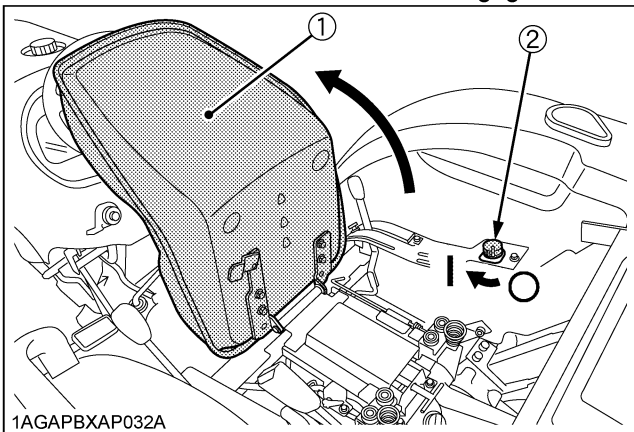

- (1) Seat
 (2) PTO clutch control switch
- ! "ON"
 ○ "OFF"

5. Set the engine speed to provide recommended rear PTO speed.

NOTE :

- If the PTO system is engaged and you stand up from the seat or the seat is not tilted forward, the engine stops automatically after standing up.

■ PTO Shaft Cover and Shaft Cap

Keep the PTO shaft cover in place at all times.

Replace the PTO shaft cap when the shaft is not in use. When connecting or disconnecting the joint to PTO shaft, raise up the PTO shaft cover.

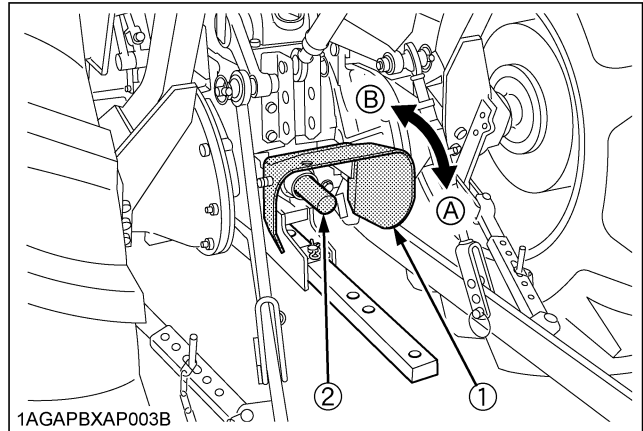

- (1) PTO shaft cover
 (2) PTO shaft cap
- (A) "NORMAL POSITION"
 (B) "RAISED POSITION"

THREE-POINT HITCH & DRAWBAR

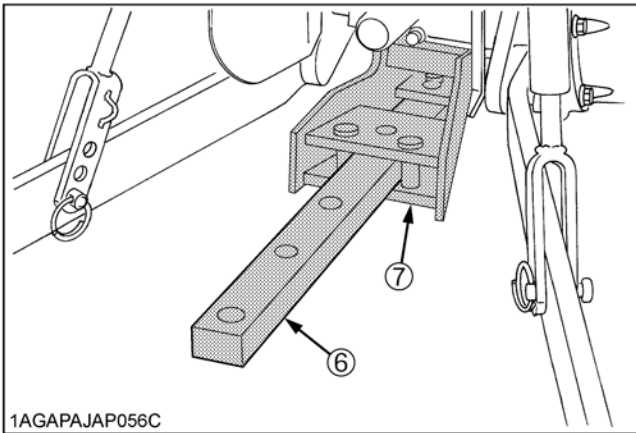
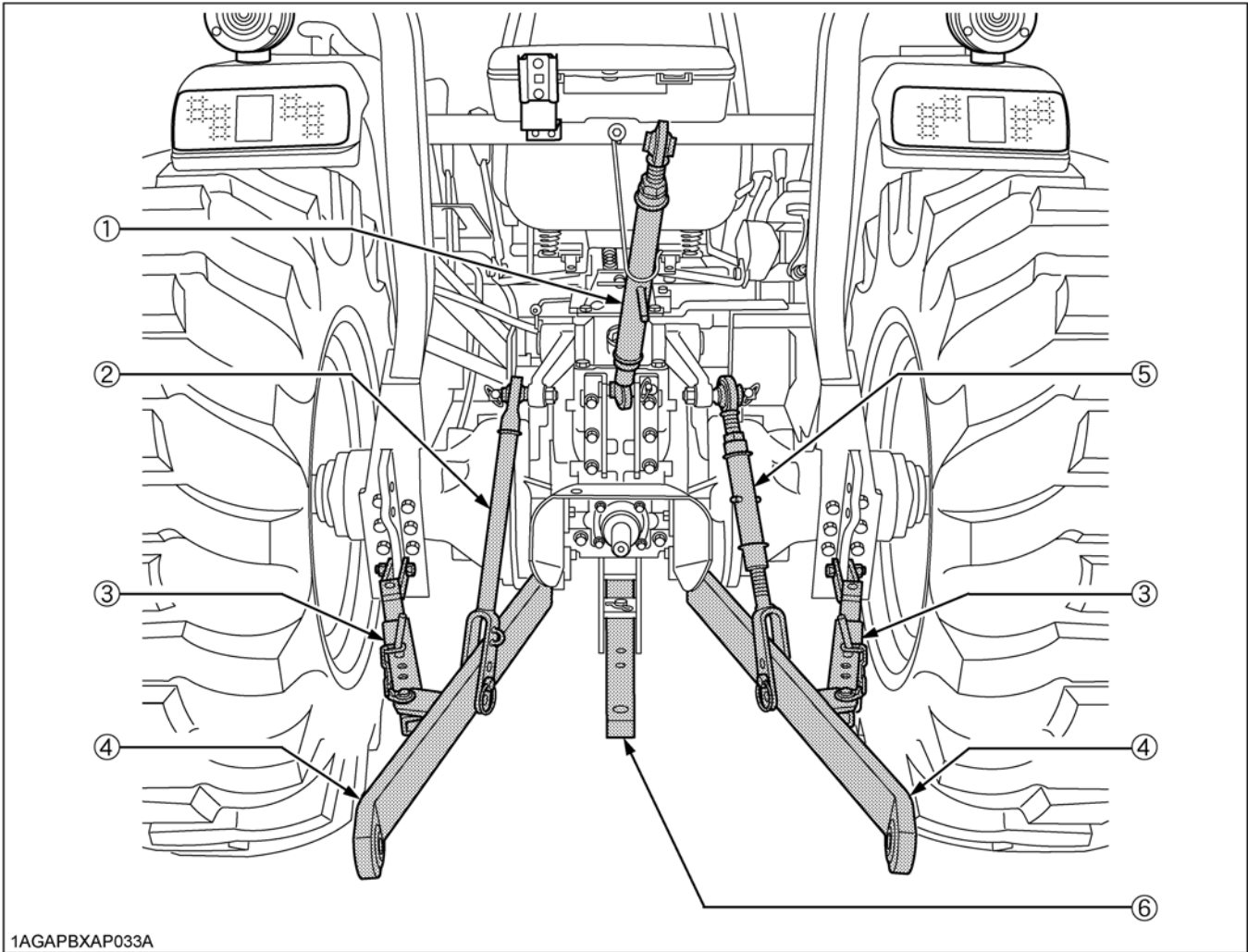

- (1) Top link
- (2) Lifting rod (Left)
- (3) Telescopic stabilizers
- (4) Lower link
- (5) Lifting rod (Right)
- (6) Drawbar
- (7) Swing drawbar frame [option]

3-POINT HITCH

1. Make preparations for attaching implement.

■ Selecting the top link mounting holes

Select the proper set of holes by referring to the "Hydraulic Control Unit Use Reference Chart" in "HYDRAULIC UNIT" section.

If the hydraulic unit is set for draft control, draft response is more sensitive when an implement is connected to the upper set of top link mounting holes. If draft control is not required, it is recommended to use the low set (4).

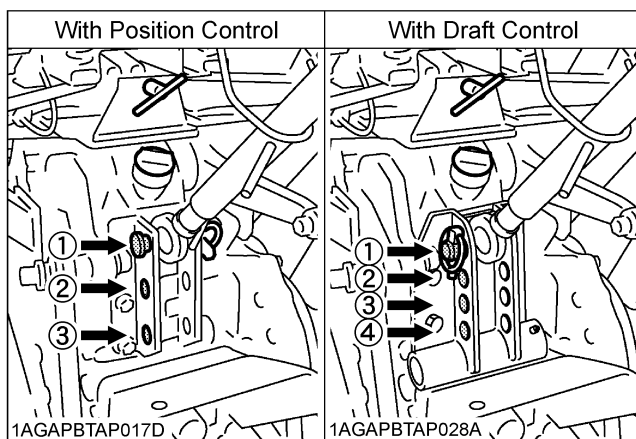

■ Drawbar

Remove the drawbar if a close mounted implement is attached.

2. Attaching and detaching implements



CAUTION

To avoid personal injury:

- Be sure to stop the engine.
- Do not stand between tractor and implement unless parking brake is applied.
- Before attaching or detaching implement, locate the tractor and implement on a firm level surface.
- Whenever an implement or other attachment is connected to the tractor 3-point hitch, check full range of operation for interference, binding or PTO separation.

■ Lifting Rod (Right)

Level a 3-point mounted implement from side to side by turning the adjusting handle to shorten or lengthen the adjustable lifting rod with the implement on the ground. After adjustment, tighten the lock nut securely.

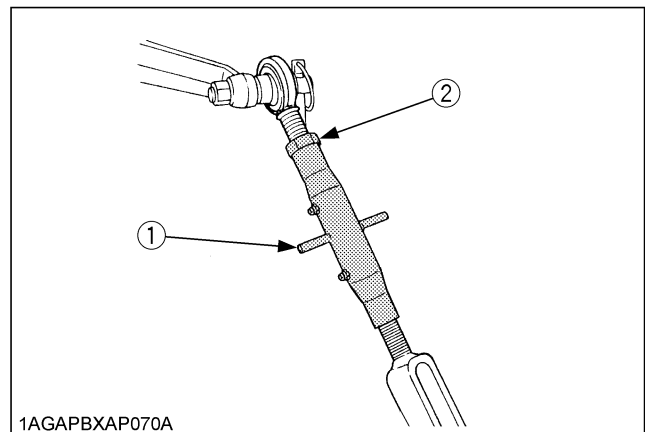

- (1) Adjusting handle
(2) Lock nut

■ Top Link

1. Adjust the angle of the implement to the desired position by shortening or lengthening the top link. After adjustment, tighten the lock nut securely.
2. The proper length of the top link varies according to the type of implement being used.

Telescopic Stabilizers

Adjust the telescopic stabilizers to control horizontal sway of the implement. Select the proper set of holes by referring to the "Hydraulic Control Unit Use Reference Chart" in "REMOTE HYDRAULIC CONTROL SYSTEM" in "HYDRAULIC UNIT" section.

After aligning satisfactorily, insert the set-pin through any one of the four holes on the outer tube that align with one of the holes on the inner bar, both stabilizers will be locked.

If the set-pin is inserted through the slot to engage one of the holes on the inner bar, a limited degree of sway will be permitted.

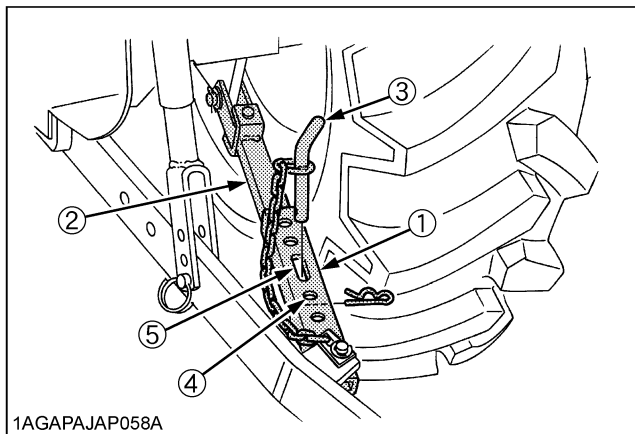

- (1) Outer tube
- (2) Inner bar
- (3) Set-pin
- (4) Hole
- (5) Slot

DRAWBAR

WARNING

To avoid personal injury:

- Never pull from the top link, the rear axle or any point above the drawbar. Doing so could cause the tractor to tip over rearward causing personal injury or death.

Adjusting Drawbar Length

When towing an implement, recommend use of (B) hole in drawbar.

The drawbar load is referred to "IMPLEMENT LIMITATIONS" section.

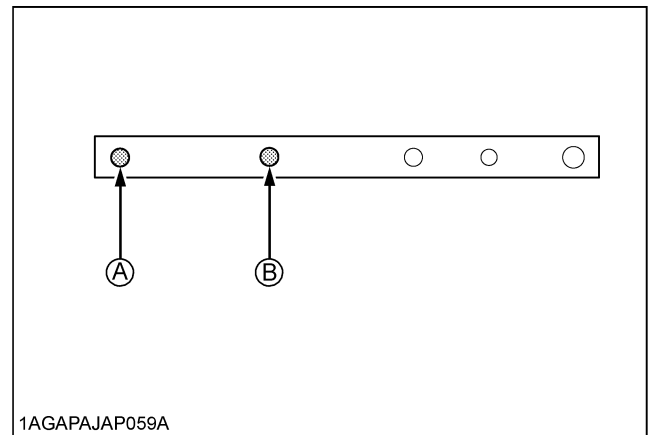
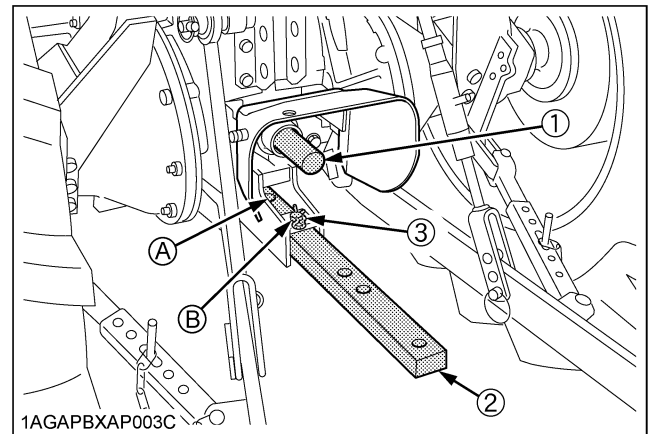

- (1) PTO shaft
- (2) Drawbar
- (3) Pivot pin

Holes : (A),(B)

■ **Swing Drawbar(if equipped)**

The drawbar can be used in three different ways as illustrated below. Assemble it correctly with joint pins set at the points as marked by • in the figure.

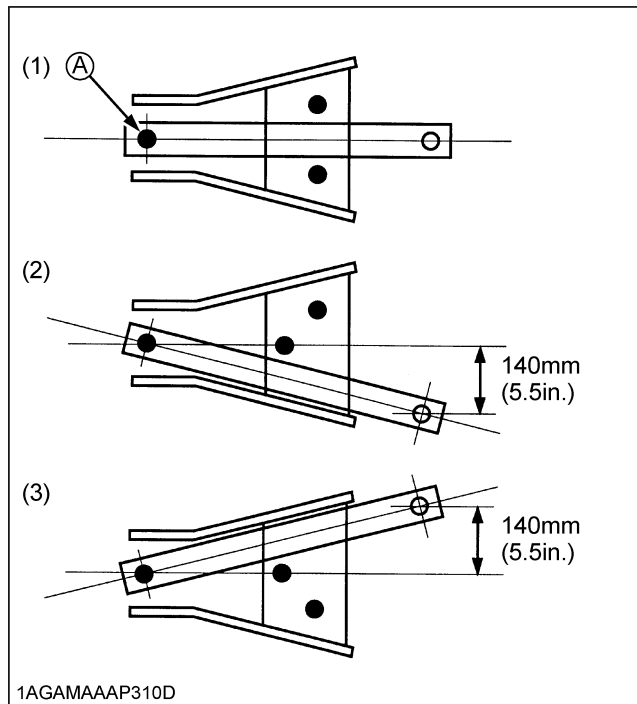

Hole : A

HYDRAULIC UNIT

IMPORTANT :

- Do not operate until the engine is warmed up. If operation is attempted when the engine is still cold, the hydraulic system may be damaged.
- If noises are heard when implement is lifting after the hydraulic control lever has been activated, the hydraulic mechanism is not adjusted properly. Unless corrected, the unit will be damaged. Contact your KUBOTA Dealer for adjustment.

3-POINT HITCH CONTROL SYSTEM

■ Position Control

This will control the working depth of 3-point implements regardless of the amount of pull required.

Place the draft control lever in the lowest position and set the implement working depth with the position control lever.

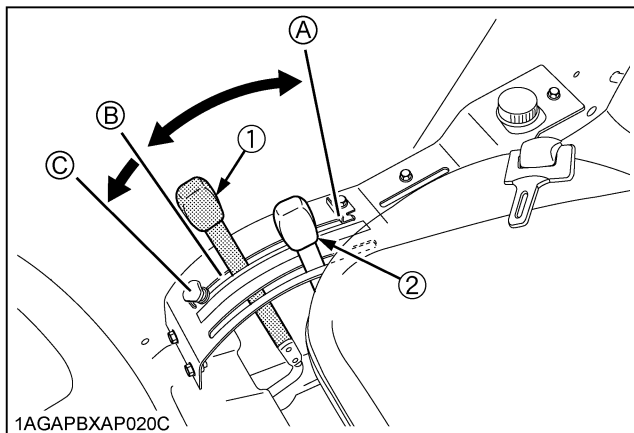

- (1) Position control lever
(2) Draft control lever [if equipped]

- (A) "UP"
(B) "DOWN"
(C) "FLOAT"

■ Draft Control (if equipped)

This will control the pull of the 3-point implement. As the load on the 3-point hitch changes due to various soil conditions, the draft control system automatically responds to these changes by either raising or lowering the implement slightly to maintain a constant pull.

Place the position control lever in the lowest position and set the implement pull with the draft control lever.

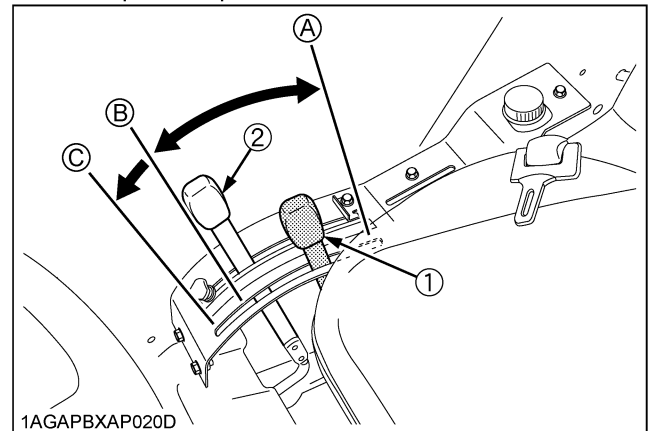

- (1) Draft control lever
(2) Position control lever

- (A) "SENSITIVE"
(B) "INSENSITIVE"
(C) "FLOAT"

■ Mixed Control

In draft control, when draft decreases, the implement automatically lowers to increase draft. However, the implement sometimes lowers too much. To limit the degree, the implement can be lowered, set the position control lever at the lowest working depth desired for the implement. Lower the draft control lever to the point where the implement is at the desired depth.

This stops the implement from going too deep and causing loss of traction and ground speed.

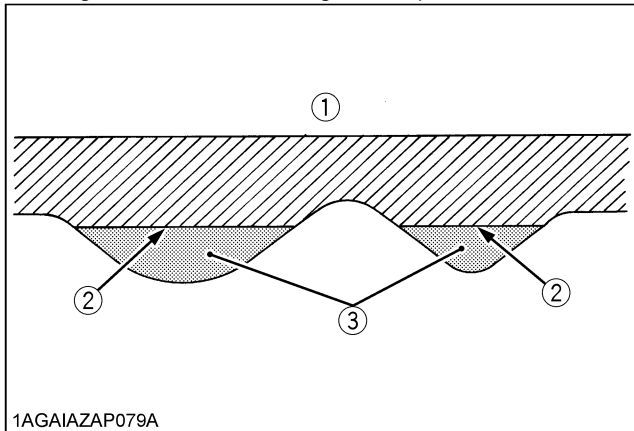

1AGAIAZAP079A

- (1) Ground surface
- (2) Implement penetrate limit
- (3) Light soil

■ Float Control

[with Draft control]

Place both the draft control lever and the position control lever in the float position to make the lower links move freely along with the ground conditions.

[with Position control]

Place the position control lever in the float position to make the lower links move freely along with the ground conditions.

■ 3-point Hitch Lowering Speed



CAUTION

To avoid personal injury:

- Fast lowering speed may cause damage or injury. Lowering speed of implement should be adjusted to two or more seconds.

The lowering speed of the 3-point hitch can be controlled by adjusting the 3-point hitch lowering speed knob.

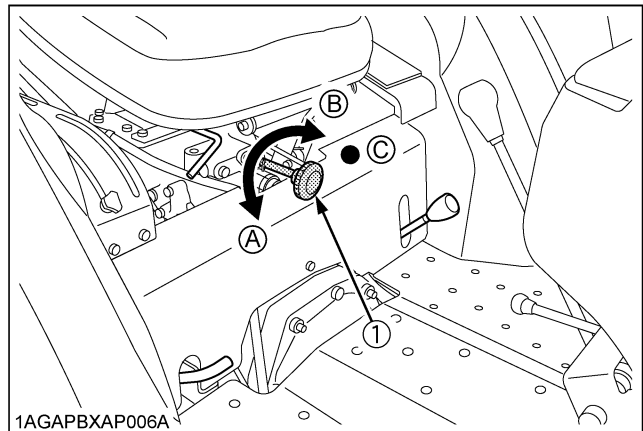

1AGAPBXAP006A

- (1) 3-point hitch lowering speed knob
- (A) "FAST"
- (B) "SLOW"
- (C) "LOCK"

AUXILIARY HYDRAULICS

Hydraulic Block Type Outlet

Hydraulic block type outlet is useful when adding hydraulically operated equipment such as: front end loader, front blade, etc.

When implement is attached

1. Remove the block cover.
2. Route the implement inlet, outlet, and return hoses as shown in the illustration.

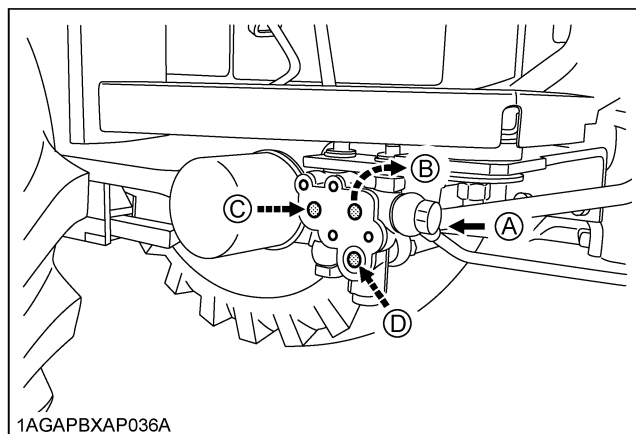
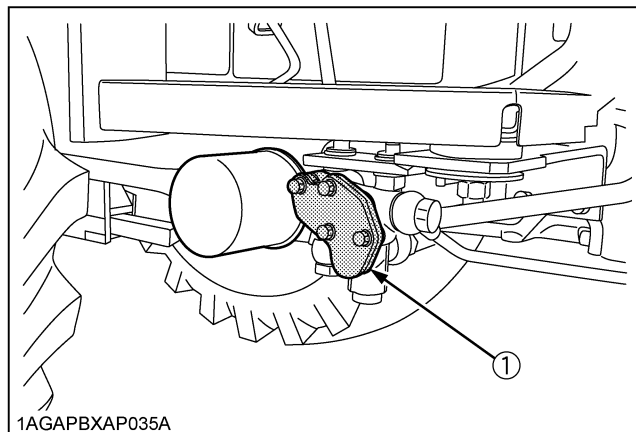

(1) Block cover

- (A) Front gear pump
- (B) To implement
Max flow
31.7 L/min (8.4 gals./min)
Max pressure
17.7 MPa (180 kgf/cm²)
- (C) From implement (Outlet)
- (D) From implement (Tank port)

REMOTE HYDRAULIC CONTROL SYSTEM (if equipped)

The hydraulic auxiliary control valves can be installed up to triple segments.

Remote Control Valve

There are two types of remote valves available for these models.

- Double acting valve:
- Double acting valve with float position:
This valve may be placed in the float mode with the control lever all the way forward. The cylinder is free to extend or retract, letting an implement such as a loader bucket follow the ground.

NOTE :

- The floating valve can be attached as the second segment only.
- It is possible to use double segments with BH92 backhoe.

Remote Control Valve Lever

The remote control valve lever directs pressurized oil flow to the implement hydraulic system.

[Example: Installing triple segment valve]

1st 3rd	Double acting valve
2nd	Double acting valve with float position

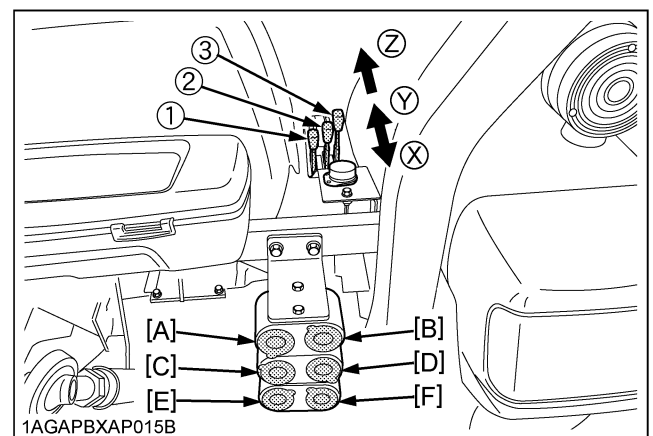

- (1) Remote control valve lever with Double acting valve (1)
- (2) Remote control valve lever with Double acting valve / Float position (2)
- (3) Remote control valve lever with Double acting valve (3)
- (X) "REARWARD"
- (Y) "FORWARD"
- (Z) "FULL FORWARD"

Pressure →
 Returning ←

Lever (1)		---		Forward		Rearward	
Port	[A]	---		In	←	Out	→
	[B]	---		Out	→	In	←
Lever (2)		Full Forward		Forward		Rearward	
Port	[C]	In	Float	In	←	Out	→
	[D]	Out		Out	→	In	←
Lever (3)		---		Forward		Rearward	
Port	[E]	---		In	←	Out	→
	[F]	---		Out	→	In	←
				Coupler size			
Port [A] [B] [C] [D] [E] [F]				PT 1/2			

IMPORTANT :

- Do not hold the lever in the "REARWARD" or "FORWARD" position once the remote cylinder has reached the end of the stroke, as this will cause oil to flow through the relief valve. Forcing oil through the relief valve for extended periods will overheat the oil.
- When using the tractor hydraulic system to power front loader, do not operate boom and bucket cylinders simultaneously.

NOTE :

- To use the single-acting cylinder with the float valve, connect this cylinder to the [C] port.
 To extend a single-acting cylinder, pull the remote control valve lever rearward. To retract a cylinder, push it fully forward to the "FLOAT" position. Do not hold it in the down position, the transmission fluid may be overheat.

Remote Control Valve Coupler Connecting and Disconnecting



CAUTION

To avoid personal injury:

- Stop the engine and relieve pressure before connecting or disconnecting lines.
- Do not use your hand to check for leaks.

◆ Connecting

1. Clean both couplers.
2. Remove dust plugs.
3. Insert the implement coupler to the tractor hydraulic coupler.
4. Pull the implement coupler slightly to make sure couplers are firmly connected.

◆ Disconnecting

1. Lower the implement first to the ground to release hydraulic pressure in the hoses.
2. Clean the couplers.
3. Relieve pressure by moving hydraulic control levers with engine shut off. Pull the hose straight from the hydraulic coupler to release it.
4. Clean oil and dust from the coupler, then replace the dust plugs.

NOTE :

- Your local KUBOTA Dealer can supply parts to adapt couplers to hydraulic hoses.

Hydraulic Control Unit Use Reference Chart

In order to handle the hydraulics properly, the operator must be familiar with the following. Though this information may not be applicable to all types of implements and soil conditions, it is useful for general conditions.

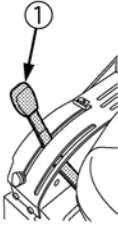
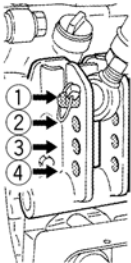
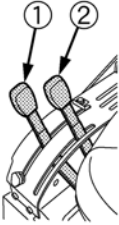
Implement	Soil condition	with Position control		with Draft control		Gauge wheel	Telescopic stabilizers	Remarks
		1AGAMAAAP314B 	1AGAPAAAAP043F 	1AGAMAAAP315A 	1AGAPAJAP006F 			
Moldboard plow	Light soil Medium soil Heavy soil	1 or 2 2 or 3 3	Position control	1 or 2 2 or 3 3	Draft and Mixed control	YES/NO	Loose	Insert the set-pin through the slot on the outer tube that align with one of the holes on the inner bar. For implements with gauge wheels, lower the position control lever all way.
Disc plow	---	2 or 3		2 or 3				
Harrow (spike, springtooth, disc type)	---	2 or 3		2 or 3	Place the draft control lever to the suitable position and set the implement pull with the position control lever			
Sub-soiler ...	---	2 or 3		2 or 3				
Weeder, ridger...	---	3	Position control	4	Position control	YES	Tighten	Telescopic stabilizer should be tight enough to prevent excessive implement movement when implement is in raised position.
Earthmover, digger, scraper, manure fork, rear carrier.....					Hold the draft control lever at the most front position during operation.	YES/NO		
Mower (mid- and rear-mount type)					NO			

TIRES, WHEELS AND BALLAST

TIRES

WARNING

To avoid personal injury:

- Do not attempt to mount a tire on a rim. This should be done by a qualified person with the proper equipment.
- Always maintain the correct tire pressure. Do not inflate tires above the recommended pressure shown in the operator's manual.

IMPORTANT :

- Do not use tires other than those approved by KUBOTA.

■ Inflation Pressure

Though the tire pressure is factory-set to the prescribed level, it naturally drops slowly in the course of time. Thus, check it everyday and inflate as necessary.

NOTE :

- Maintain the maximum pressure in front tires, if using a front loader or when equipped with a full load of front weights.

	Tire sizes	Inflation Pressure
Rear	14.9-24, 6PR	140 kPa (1.4 kgf/cm ² , 20 psi)
	44 x 18-20, 4PR	140 kPa (1.4 kgf/cm ² , 20 psi)
	17.5L-24, 6PR	140 kPa (1.4 kgf/cm ² , 20 psi)
Front	6.00-16, 4PR	220 kPa (2.2 kgf/cm ² , 32 psi)
	8.3-16, 6PR	150 kPa (1.5 kgf/cm ² , 22 psi)
	27 x 8.50-15, 4PR	80 kPa (0.8 kgf/cm ² , 11 psi)
	29 x 12.50-15, 4PR	140 kPa (1.4 kgf/cm ² , 20 psi)
	10-16.5, 6PR	140 kPa (1.4 kgf/cm ² , 20 psi)
	7.5L-15, 6PR	220 kPa (2.2 kgf/cm ² , 32 psi)
	27-10.50LL15, 4PR	80 kPa (0.8 kgf/cm ² , 11 psi)
	305R343	140 kPa (1.4 kgf/cm ² , 20 psi)

■ Dual Tires

Dual tires are not approved.

WHEEL ADJUSTMENT

CAUTION

To avoid personal injury:

- When working on slopes or when working with trailer, set the wheel tread as wide as practical for maximum stability.
- Support tractor securely on stands before removing a wheel.
- Do not work under any hydraulically supported devices. They can settle, suddenly leak down, or be accidentally lowered. If necessary to work under tractor or any machine elements for servicing or adjustment, securely support them with stands or suitable blocking beforehand.
- Never operate tractor with a loose rim, wheel, or axle.

■ Front Wheels (with two wheel drive)

Front tread width can be adjusted as shown with the standard equipped tires.

To change the tread width

1. Remove the front axle mounting bolts and the tie-rod mounting bolts.
2. Move the front axles (right and left) to the desired position, and tighten the bolts.
3. Adjust the toe-in: [2 to 8mm (0.1 to 0.3 in.)] (See "Adjusting Toe-in" in "EVERY 200 HOURS" in "PERIODIC SERVICE" section.)

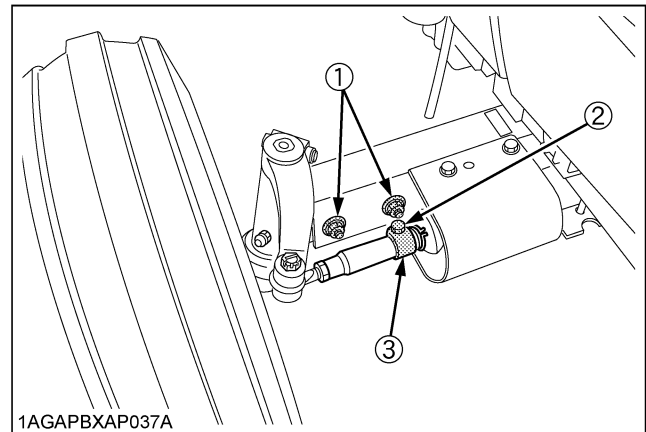

- (1) Front axle mounting bolt
124 to 147 N-m (12.6 to 15 kgf-m) [91.5 to 108.9 ft-lbs.]
- (2) Tie-rod mounting bolt
61 to 71 N-m (6.2 to 7.2 kgf-m) [44.8 to 52.1 ft-lbs.]
- (3) Tie rod clamp

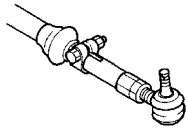
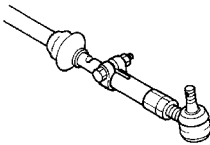
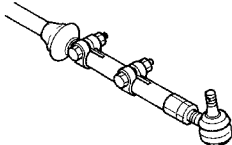
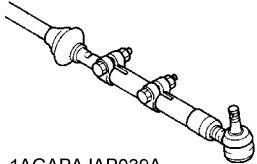
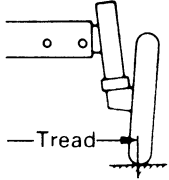
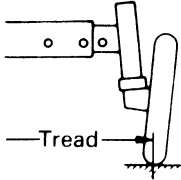
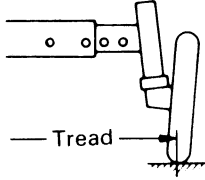
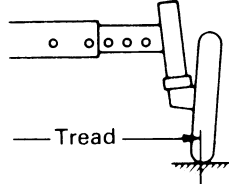
Models		 1AGAPAJAP036A	 1AGAPAJAP037A	 1AGAPAJAP038A	 1AGAPAJAP039A
		 —Tread—	 —Tread—	 —Tread—	 —Tread—
Farm	6.00-16	1210 mm (47.6 in.)	1310 mm (51.6 in.)	1410 mm (55.5 in.)	1510 mm (59.4 in.)
	7.5L-15	1280 mm (50.4 in.)	1380 mm (54.3 in.)	1480 mm (58.3 in.)	1580 mm (62.2 in.)
Turf	27x8.5-15	1235 mm (48.6 in.)	1335 mm (52.6 in.)	1435 mm (56.5 in.)	1535 mm (60.4 in.)

IMPORTANT :

- The front tread width for the front loader application on 2WD models should not be greater than 1280 mm (50.4 in.).

NOTE :

- Wheels with beveled or tapered holes: Use the tapered side of lug nut.

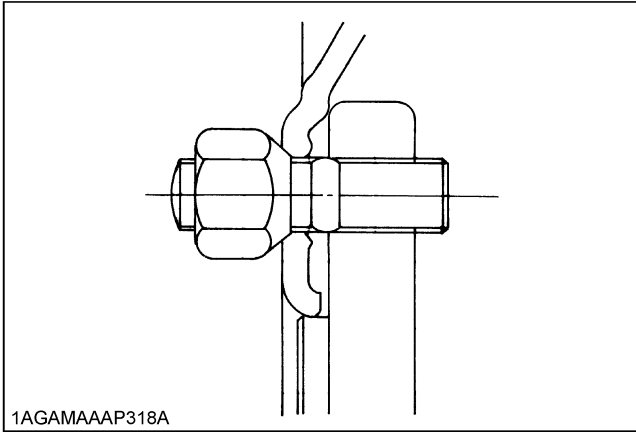

Front Wheels (with four wheel drive)

Front tread can not be adjusted.

IMPORTANT :

- Do not turn front discs to obtain wider tread.
- When re-fitting or adjusting a wheel, tighten the bolts to the following torques then recheck after driving the tractor 200 m (200 yards) and 10 times of shuttle movement by 5 m (5 yards), and thereafter according to service interval.
(See "MAINTENANCE" section.)

NOTE :

- Wheels with beveled or tapered holes: Use the tapered side of lug nut.

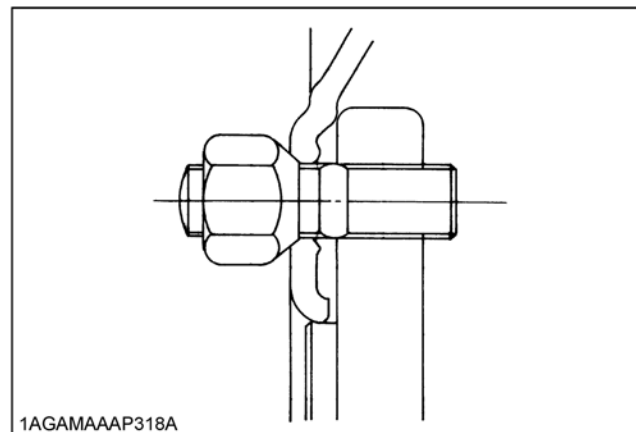
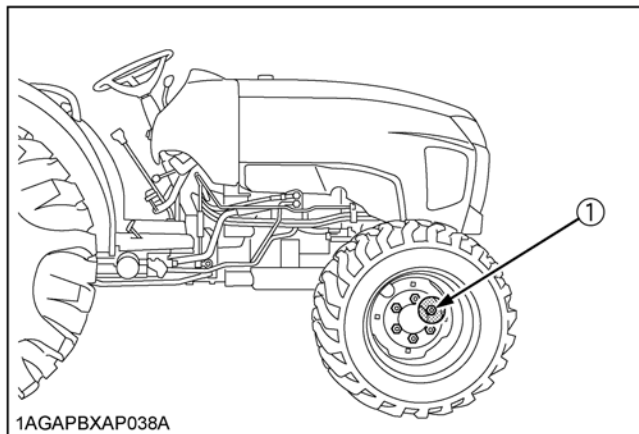

(1) 124.0 to 147.0 N-m (12.6 to 15.0 kgf-m, 91.5 to 108.4 ft-lbs)

<p>Tread</p> <p>1AGAMAAAP392A</p>	Tire	8.3-16 Farm	27 x 8.50-15 Turf	27 x 10.50LL15 Turf	305R343 Turf	10-16.5 IND
	Tread	1155 mm (45.5 in.)	1200 mm (47.2 in.)	1180 mm (46.5 in.)	1305 mm (51.4 in.)	1195 mm (47.0 in.)

NOTE :

- IND...for Industrial

■ Rear Wheels

Rear tread width can be adjusted as shown with the standard equipped tires.

To change the tread width

1. Remove the wheel rim and / or disk mounting bolts.
2. Change the position of the rim and / or disk (right and left) to the desired position, and tighten the bolts.

IMPORTANT :

- Always attach wheels as shown in the drawings.
- If not attached as illustrated, transmission parts may be damaged.
- When re-fitting or adjusting a wheel, tighten the bolts to the following torques then recheck after driving the tractor 200 m (200 yards) and 10 times of shuttle movement by 5 m (5 yards), and thereafter according to service interval.
(See "MAINTENANCE" section.)

NOTE :

- If Backhoe is attached, use the tread widths other than * widths in the chart.

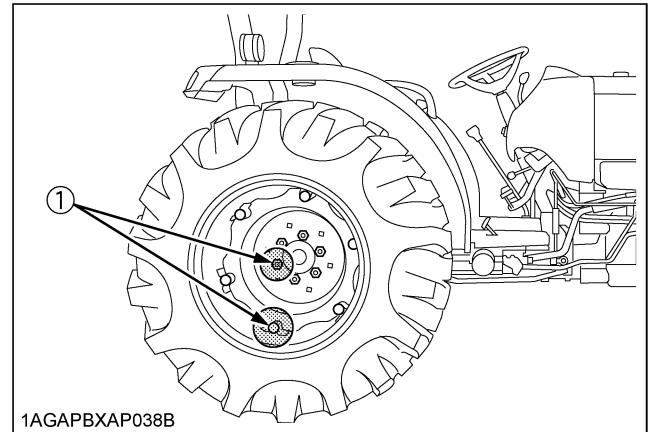

1AGAPBXAP038B

(1) 196.0 to 225.0 N-m (20.0 to 23.0 kgf-m, 144.6 to 166.0 ft-lbs)

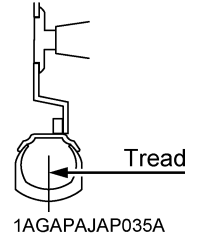
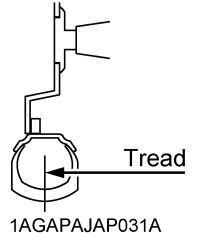
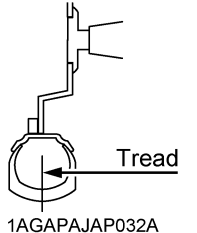
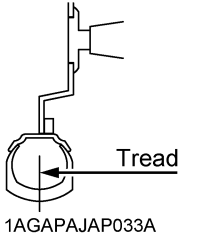
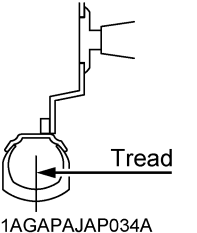
Models					
14.9-24 Farm	* 1180 mm (46.5 in.)	* 1200 mm (47.2 in.)	1300 mm (51.2 in.)	1450 mm (57.1 in.)	1545 mm (60.8 in.)
17.5L-24 IND	---	* 1250 mm (49.2 in.)	1360 mm (53.5 in.)	1390 mm (54.7 in.)	1500 mm (59.1 in.)

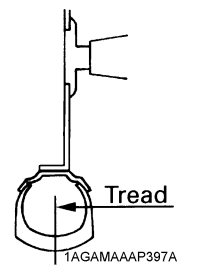
Models	
44x18-20 Turf	1430 mm (56.3 in.)

BALLAST

CAUTION

To avoid personal injury:

- Additional ballast will be needed for transporting heavy implements. When the implement is raised, drive slowly over rough ground, regardless of how much ballast is used.
- Do not fill the front wheels with liquid to maintain steering control.

■ Front Ballast

Add weights if needed for stability (2WD, 4WD models) and improve traction (4WD model). Heavy pulling and heavy rear mounted implements tend to lift front wheels. Add enough ballast to maintain steering control and prevent tip over. Remove weight when no longer needed.

◆ Front End Weights (option)

The front end weights can be attached to the bumper. See your implement operator's manual for required number of weights or consult your local KUBOTA Dealer to use.

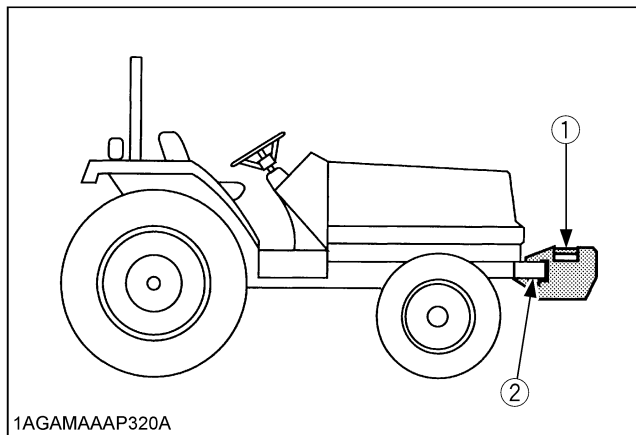

(1) Front end weights
(2) Bumper

IMPORTANT :

- Do not overload tires.
- Add no more weight than indicated in chart.

NOTE :

- The front end weights can be attached to the bumper (option on 4WD models).

Maximum weight	25 kg x 7 pieces (386 lbs.)
----------------	--------------------------------

■ Rear Ballast

Add weight to rear wheels if needed to improve traction or for stability. The amount of rear ballast should be matched to job and the ballast should be removed when it is not needed.

The weight should be added to the tractor in the form of liquid ballast, rear wheel weights or a combination of both.

◆ Rear Wheel Weights (option)

The rear wheel weights can be attached to the rear wheel. See your implement operator's manual for required number of weights or consult your local KUBOTA Dealer to use.

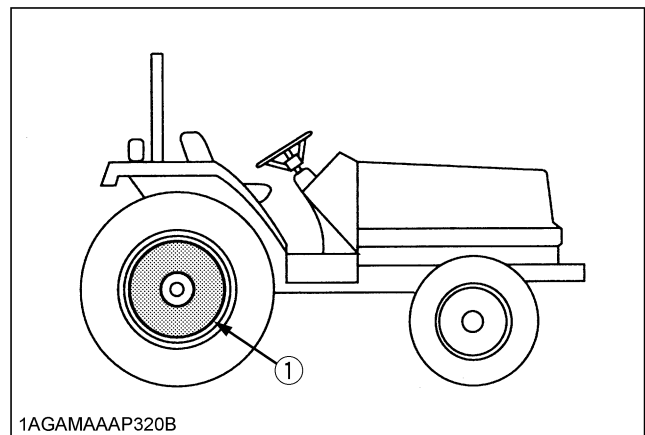

(1) Rear wheel weights

IMPORTANT :

- Do not overload tires.
- Add no more weight than indicated in chart.

Maximum weight per wheel	28 kg x 3 Pieces (185 lbs.)
--------------------------	--------------------------------

■ Liquid Ballast in Rear Tires

Water and calcium chloride solution provides safe economical ballast. Used properly, it will not damage tires, tubes or rims. The addition of calcium chloride is recommended to prevent the water from freezing. Use of this method of weighting the wheels has the full approval of the tire companies. See your tire dealer for this service.

Liquid weight per tire (75 Percent filled)

Tire sizes	14.9-24	17.5L-24
Slush free at -10 °C (14 °F) Solid at -30 °C (-22 °F) [Approx. 1 kg (2 lbs.) CaCl ₂ per 4 L (1 gal) of water]	205 kg (450 lbs.)	235 kg (515 lbs.)
Slush free at -24 °C (-11 °F) Solid at -47 °C (-52 °F) [Approx. 1.5 kg (3.5 lbs.) CaCl ₂ per 4 L (1 gal) of water]	215 kg (475 lbs.)	250 kg (550 lbs.)
Slush free at -47 °C (-52 °F) Solid at -52 °C (-62 °F) [Approx. 2.25 kg (5 lbs.) CaCl ₂ per 4 L (1 gal) of water]	225 kg (495 lbs.)	265 kg (585 lbs.)

IMPORTANT :

- Do not fill tires with water or solution more than 75% of full capacity (to the valve stem level at 12 o'clock position).

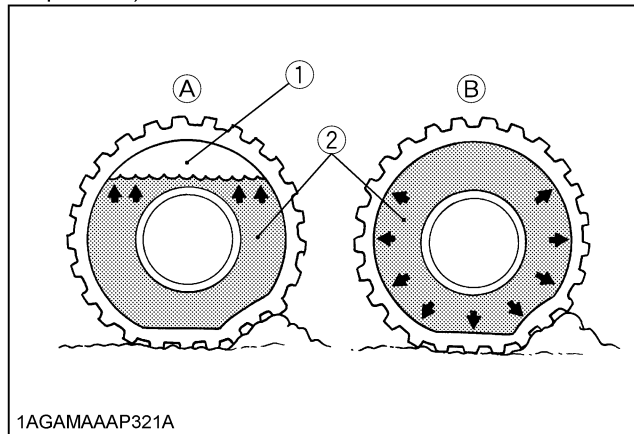

- (1) Air (A) Correct-75% Air compresses like a cushion
 (2) Water (B) Incorrect-100% Full Water can not be compressed

MAINTENANCE

SERVICE INTERVALS

No.	Items		Indication on hour meter													Interval	Ref. page			
			50	100	150	200	250	300	350	400	450	500	550	600	650					700
1	Greasing	-	○	○	○	○	○	○	○	○	○	○	○	○	○	○	every 50 Hr	60		
2	Engine start system	Check	○	○	○	○	○	○	○	○	○	○	○	○	○	○	every 50 Hr	61		
3	Wheel bolt torque	Check	○	○	○	○	○	○	○	○	○	○	○	○	○	○	every 50 Hr	62		
4	Tie-rod dust cover	Check	○	○	○	○	○	○	○	○	○	○	○	○	○	○	every 50 Hr	62	*4	
5	Battery condition	Check		○		○		○		○		○		○		every 100 Hr	65	*5		
6	Fan belt	Adjust		○		○		○		○		○		○		every 100 Hr	64			
7	Clutch	Adjust	◎	○		○		○		○		○		○		every 100 Hr	59			
8	Brake	Adjust		○		○		○		○		○		○		every 100 Hr	65			
9	Air cleaner element	Primary element	Clean		○		○		○		○		○		○	every 100 Hr	63	*1	@	
		Replace														every 1 year	72	*2		
		Secondary element	Replace														every 1 year	72		
10	Fuel filter element	Clean		○		○		○		○		○		○		every 100 Hr	63		@	
		Replace								○						every 400 Hr	72			
11	Fuel line	Check		○		○		○		○		○		○		every 100 Hr	64		@	
		Replace														every 2 year	74	*4		
12	Engine oil	Change	◎			○				○				○		every 200 Hr	67			
13	Engine oil filter	Replace	◎			○				○				○		every 200 Hr	66			
14	Transmission oil filter [HST]	Replace	◎			○				○				○		every 200 Hr	67			
15	Toe-in	Adjust				○				○				○		every 200 Hr	69			
16	Radiator hose and clamp	Check				○				○				○		every 200 Hr	68			
		Replace														every 2 year	74			

No.	Items		Indication on hour meter													Interval	Ref. page			
			50	100	150	200	250	300	350	400	450	500	550	600	650					700
17	Power steering oil line	Check				○				○				○			every 200 Hr	69		
		Replace															every 2 year	74	*4	
18	Intake air line	Check				○				○				○			every 200 Hr	69		
		Replace															every 2 year	74	*4	@
19	Oil cooler line [HST]	Check				○				○				○			every 200 Hr	68		
		Replace															every 2 year	74	*4	
20	Hydraulic oil filter	Replace	◎							○							every 400 Hr	70		
21	Transmission fluid	Change								○							every 400 Hr	70		
22	Front axle case oil (4WD)	Change								○							every 400 Hr	71		
23	Greasing (2WD front wheel hub)	-								○							every 400 Hr	72		
24	Front axle pivot	Adjust												○			every 600 Hr	72		
25	Engine valve clearance	Adjust															every 800 Hr	72	*4	
26	Fuel injection nozzle Injection pressure	Check															every 1500 Hr	72	*4	@
27	Injection pump	Check															every 3000 Hr	72	*4	@
28	Cooling system	Flush															every 2 year	72		
29	Coolant	Change															every 2 year	72		
30	Fuel system	Bleed															Service as required	74		
31	Clutch housing water	Drain														75				
32	Fuse	Replace														75				
33	Light bulb	Replace														76				

IMPORTANT :

- The jobs indicated by ◎ must be done after the first 50 hours of operation.
- *1 Air cleaner should be cleaned more often in dusty conditions than in normal conditions.
- *2 Every year or every 6 times of cleaning.
- *3 Replace only if necessary.
- *4 Consult your local KUBOTA Dealer for this service.
- *5 When the battery is used for less than 100 hours per year, check the battery condition by reading the indicator annually.
- The items listed above (@ marked) are registered as emission related critical parts by KUBOTA in the U.S.EPA nonroad emission regulation. As the engine owner, you are responsible for the performance of the required maintenance on the engine according to the above instruction.
Please see Warranty Statement in detail.

LUBRICANTS, FUEL AND COOLANT

No.	Locations	Capacities	Lubricants	
1	Fuel	48.0 L (12.7 U.S.gals.)	No. 2-D diesel fuel No. 1-D diesel fuel if temperature is below -10 °C(14 °F)	
2	Coolant	6.5 L (6.9 U.S.qts.)	Fresh clean soft water with anti-freeze	
3	Engine crankcase (with filter)	7.6 L (8.0 U.S.qts.)	• Engine oil : Refer to next page	
			Above 25°C (77°F)	SAE30, SAE10W-30 or 15W-40
			0 to 25°C (32 to 77°F)	SAE20, SAE10W-30 or 15W-40
			Below 0°C (32°F)	SAE10W, SAE10W-30 or 15W-40
4	Transmission case	40.0 L (10.6 U.S. gals.)	• KUBOTA SUPER UDT-2 fluid	
5	Front axle case [4WD]	6.5 L (6.9 U.S.qts.)	• KUBOTA SUPER UDT-2 fluid or SAE 80 - SAE 90 gear oil	
6	Greasing	No. of greasing points	Capacity	Type of grease
	• Front wheel hub	2 [2WD only]	A small amount	Bearing grease
	• Knuckle shaft	2 [2WD only]	Until grease overflows.	Multipurpose Grease NLGI-2 OR NLGI-1 (GC-LB)
	• Front axle support	2 [4WD only]		
	• Tie-rod ends	2 [4WD only]		
	• Battery terminals	2		
	• Lift rod	2		
	• Top link	2		
• Hydraulic arm shaft	2			

NOTE :

The product name of KUBOTA genuine UDT fluid may be different from that in the Operator's Manual depending on countries or territories. Consult your local KUBOTA Dealer for further detail.

For North American market

NOTE :

◆ **Engine Oil:**

- Oil used in the engine should have an American Petroleum Institute (API) service classification and Proper SAE Engine Oil according to the ambient temperatures as shown above:

- Refer to the following table for the suitable API classification engine oil according to the engine type (with internal EGR, external EGR or non-EGR) and the fuel.

Fuel used	Engine oil classification (API classification)	
	Oil class of engines except external EGR	Oil class of engines with external EGR
Ultra Low Sulfur Fuel [<0.0015% (15 ppm)]	CF, CF-4, CG-4, CH-4 or CI-4	CF or CI-4 (Class CF-4, CG-4 and CH-4 engine oils cannot be used on EGR type engines)

EGR: Exhaust Gas Re-circulation

- The CJ-4 engine oil is intended for DPF (Diesel Particulate Filter) type engines, and cannot be used on this tractor.

	except external EGR	with external EGR
Model	L4600	---

◆ **Fuel:**

- Cetane number of 45 minimum. Cetane number greater than 50 is preferred, especially for temperatures below -20 °C (-4 °F) or elevations above 1500 m (5000 ft).
- Diesel fuels specified to EN 590 or ASTM D975 are recommended.
- No.2-D is a distillate fuel of lower volatility for engines in industrial and heavy mobile service. (SAE J313 JUN87)

◆ **Transmission Oil:**

*KUBOTA Super UDT-2: For an enhanced ownership experience, we highly recommend Super UDT-2 to be used instead of standard hydraulic/transmission fluid.

Super UDT-2 is a proprietary KUBOTA formulation that delivers superior performance and protection in all operating conditions.

Regular UDT is also permitted for use in this machine.

- Indicated capacities of water and oil are manufacturer's estimate.

For other than North American market

NOTE :

◆ **Engine Oil:**

- Oil used in the engine should have an American Petroleum Institute (API) service classification and Proper SAE Engine Oil according to the ambient temperatures as shown above:
- With the emission control now in effect, the CF-4 and CG-4 lubricating oils have been developed for use of a low-sulfur fuel on on-road vehicle engines. When an off-road vehicle engine runs on a high-sulfur fuel, it is advisable to employ the "CF or better" lubricating oil with a high Total Base Number (TBN of 10 minimum).
- Refer to the following table for the suitable API classification engine oil according to the engine type (with internal EGR, external EGR or non-EGR) and the fuel (low-sulfur or high-sulfur fuel).

Fuel used	Engine oil classification (API classification)	
	Oil class of engines except external EGR	Oil class of engines with external EGR
High Sulfur Fuel [≥ 0.05% (500 ppm)]	CF (If the "CF-4, CG-4, CH-4 or CI-4" lubricating oil is used with a high-sulfur fuel, change the lubricating oil at shorter intervals. (approximately half))	---
Low Sulfur Fuel [<0.05% (500 ppm)] or Ultra Low Sulfur Fuel [<0.0015% (15 ppm)]	CF, CF-4, CG-4, CH-4 or CI-4	CF or CI-4 (Class CF-4, CG-4 and CH-4 engine oils cannot be used on EGR type engines)

EGR: Exhaust Gas Re-circulation

- The CJ-4 engine oil is intended for DPF (Diesel Particulate Filter) type engines, and cannot be used on this tractor.

	except external EGR	with external EGR
Model	L4600	---

◆ **Fuel:**

- Cetane number of 45 minimum. Cetane number greater than 50 is preferred, especially for temperatures below -20 °C or elevations above 1500 m.
- If diesel fuel with sulfur content greater than 0.5% (5000 ppm) sulfur content is used, reduce the service interval for engine oil and filter by 50%.
- NEVER use diesel fuel with sulfur content greater than 0.05% (500 ppm) for EXTERNAL EGR type engine.
- DO NOT use diesel fuel with sulfur content greater than 1.0% (10000 ppm).
- Diesel fuels specified to EN 590 or ASTM D975 are recommended.
- No.2-D is a distillate fuel of lower volatility for engines in industrial and heavy mobile service. (SAE J313 JUN87)

◆ **Transmission Oil:**

The oil used to lubricate the transmission is also used as hydraulic fluid. To insure proper operation of the hydraulic system and to complete lubrication of the transmission, it is important that a multi-grade transmission fluid is used in this system. We recommend the use of **KUBOTA UDT or SUPER UDT fluid** for optimum protection and performance. (Consult your local KUBOTA Dealer for further detail.)

Do not mix different brands together.

- Indicated capacities of water and oil are manufacturer's estimate.

PERIODIC SERVICE

CAUTION

To avoid personal injury:

- Do not work under any hydraulically supported devices. They can settle, suddenly leak down, or be accidentally lowered. If necessary to work under tractor or any machine elements for servicing or adjustment, securely support them with stands or suitable blocking beforehand.

HOW TO OPEN THE HOOD

CAUTION

To avoid personal injury from contact with moving parts;

- Never open the hood or engine side cover while the engine is running.
- Do not touch muffler or exhaust pipes while they are hot; Severe burns could result.
- Hold the hood with other hand while unlocking release lever.

■ Hood

To open the hood, hold the hood and pull the release lever and open the hood.

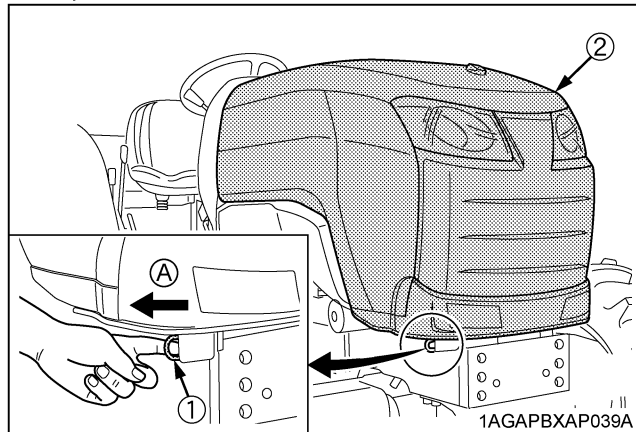

(1) Release lever
(2) Hood

(A) "PULL"

NOTE :

- To close the hood, push the hood into position using both hands.

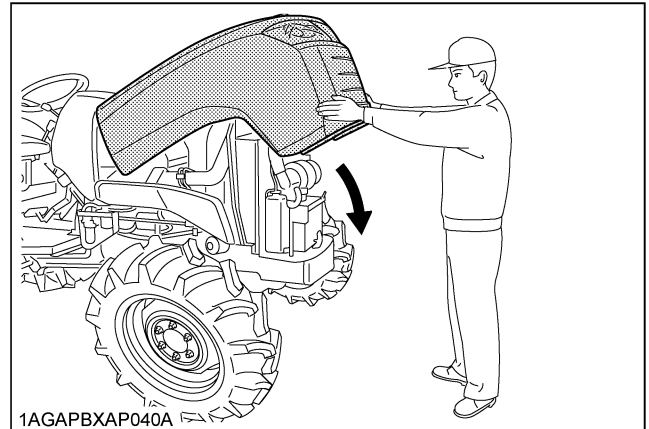

■ Side Cover

1. Remove the bolts at the both sides and detach the side cover.
2. To attach the side cover, insert the bottom pin of side cover first, and then tighten the bolts.

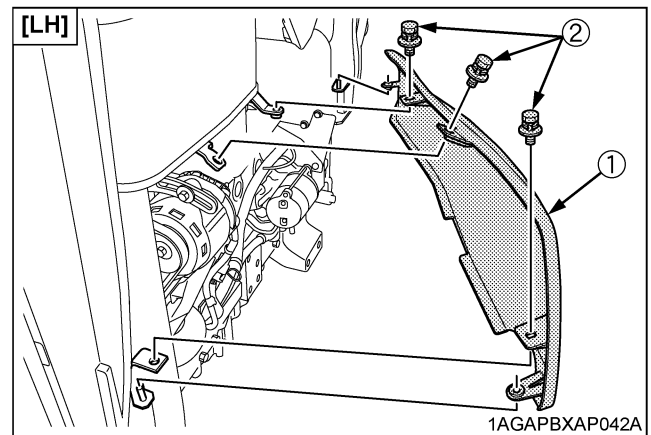

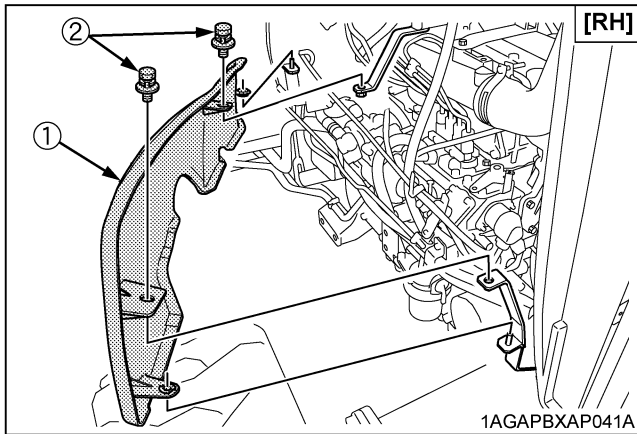

(1) Side cover
(2) Bolt

DAILY CHECK

For your own safety and maximum service life of the machine, make a thorough daily inspection before operating the machine to start the engine.



CAUTION

To avoid personal injury:

- Be sure to check and service the tractor on a level surface with the engine shut off and the parking brake "ON" and implement lowered to the ground.

Walk Around Inspection

Look around and under the tractor for such items as loose bolts, trash build-up, oil or coolant leaks, broken or worn parts.

Checking and Refueling



CAUTION

To avoid personal injury:

- Do not smoke while refueling.
- Be sure to stop the engine before refueling.

1. Turn the key switch to "ON", check the amount of fuel by fuel gauge.
2. Fill fuel tank when fuel gauge shows 1/4 or less fuel in tank.

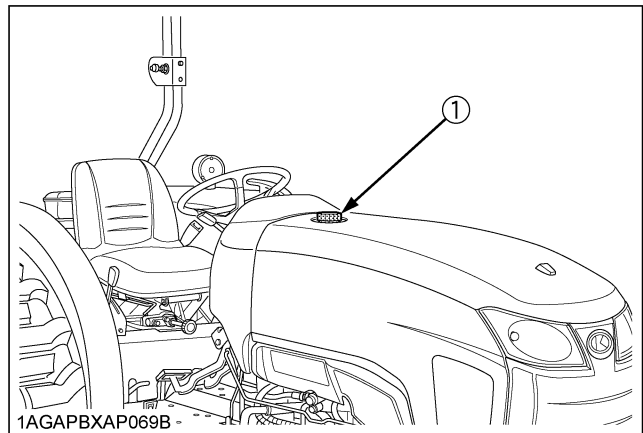

(1) Fuel tank cap

Fuel tank capacity	48 L (12.7 U.S.gals.)
--------------------	-----------------------

IMPORTANT :

- Do not permit dirt or trash to get into the fuel system.
- Be careful not to let the fuel tank become empty, otherwise air will enter the fuel system, necessitating bleeding before next engine start.
- Be careful not to spill during refueling. If a spill should occur, wipe it off at once, or it may cause a fire.
- To prevent condensation (water) accumulation in the fuel tank, fill the tank before parking overnight.

■ Checking Engine Oil Level



CAUTION

To avoid personal injury:

- Be sure to stop the engine before checking the oil level.

1. Park the machine on a flat surface.
2. Check engine oil before starting the engine or 5 minutes or more after the engine has stopped.
3. To check the oil level, draw out the dipstick, wipe it clean, replace it, and draw it out again. Check to see that the oil level lies between the two notches.

If the level is too low, add new oil to the prescribed level at the oil inlet.

(See "LUBRICANTS" in "MAINTENANCE" section.)

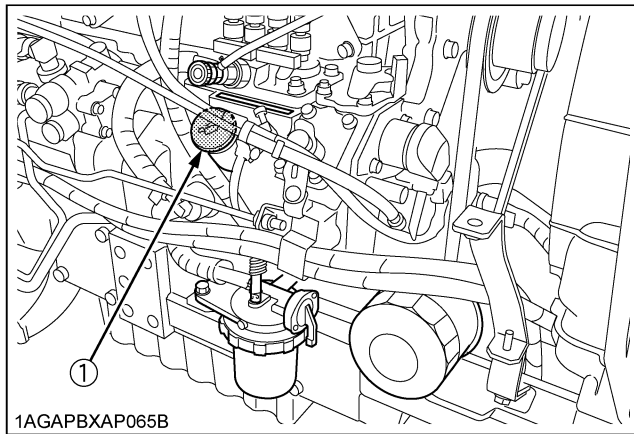

(1) Oil inlet

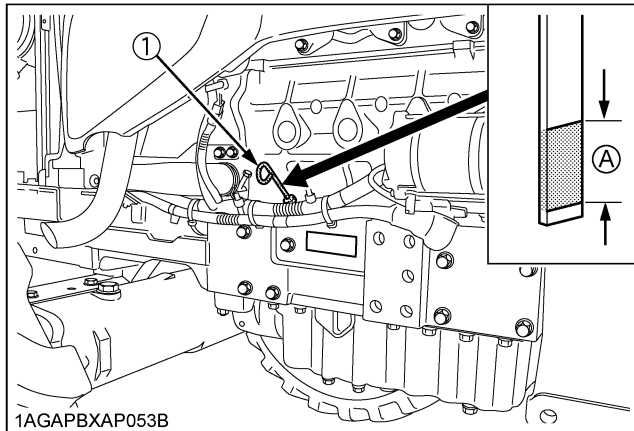

(1) Dipstick (A) Oil level is acceptable within this range.

IMPORTANT :

- When using an oil of different maker or viscosity from the previous one, remove all of the old oil. Never mix two different types of oil.
- If oil level is low, do not run engine.

■ Checking Transmission Fluid Level

1. Park the machine on a flat surface, lower the implement and shut off engine.
2. To check the oil level, draw out the dipstick, wipe it clean, replace it, and draw it out again. Check to see that the oil level lies between the two notches.

If the level is too low, add new oil to the prescribed level at the oil inlet.

(See "LUBRICANTS" in "MAINTENANCE" section.)

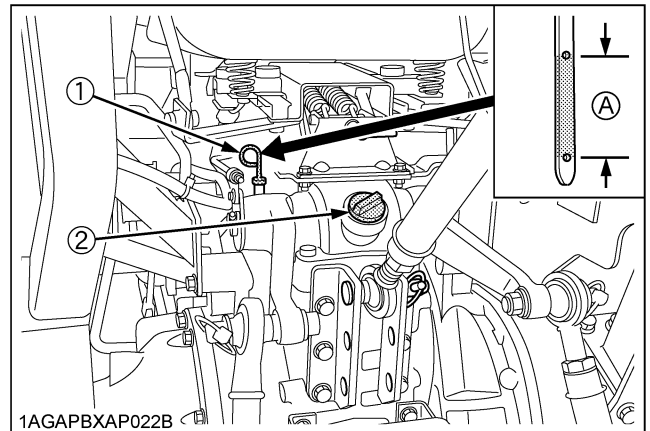

(1) Dipstick
(2) Oil inlet

(A) Oil level is acceptable within this range.

IMPORTANT :

- If oil level is low, do not run engine.

■ Checking Coolant Level

CAUTION

To avoid personal injury:

- Do not remove radiator cap while coolant is hot. When cool, slowly rotate cap to the first stop and allow sufficient time for excess pressure to escape before removing the cap completely.

1. Check to see that the coolant level is between the "FULL" and "LOW" marks of recovery tank.
2. When the coolant level drops due to evaporation, add soft water only up to the full level.
In case of leakage, add anti-freeze and soft water in the specified mixing ratio up to the full level.
(See "Flushing Cooling System and Changing Coolant" in "EVERY 2 YEARS" in "PERIODIC SERVICE" section.)
3. When the coolant level is lower than "LOW" mark of recovery tank, remove the radiator cap and check to see that the coolant level is just below the port. If level is low, add coolant.

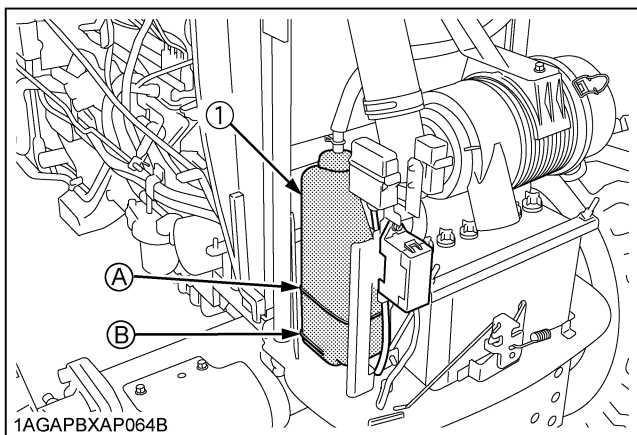

(1) Recovery tank

(A) "FULL"
(B) "LOW"

IMPORTANT :

- If the radiator cap has to be removed, follow the caution above and securely retighten the cap.
- Use clean, fresh soft water and anti-freeze to fill the radiator.
- If coolant should leak, consult your local KUBOTA Dealer.

■ Cleaning Evacuator Valve

Open the evacuator valve to get rid of large particles of dust and dirt.

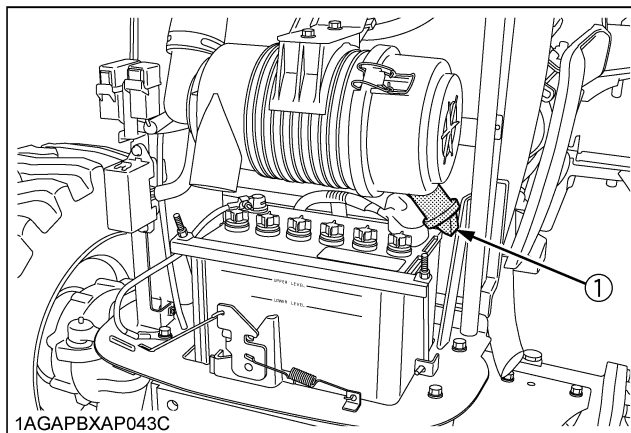

(1) Evacuator valve

■ Cleaning Grill, Radiator Screen and Oil Cooler

CAUTION

To avoid personal injury:

- Be sure to stop the engine before removing the screen.

1. Check front grill and side screens to be sure they are clean of debris.
2. Detach the screen with the fixed spring being held up and remove all foreign materials and clean the front of radiator completely.

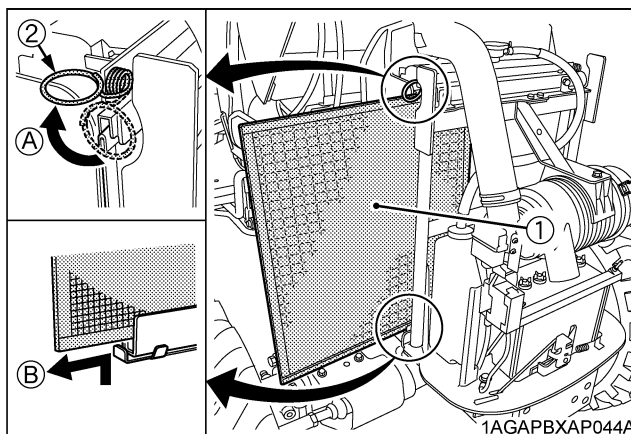

(1) Radiator screen
(2) Fixed spring

(A) "HOLD UP"
(B) "DETACH"

[HST Type]

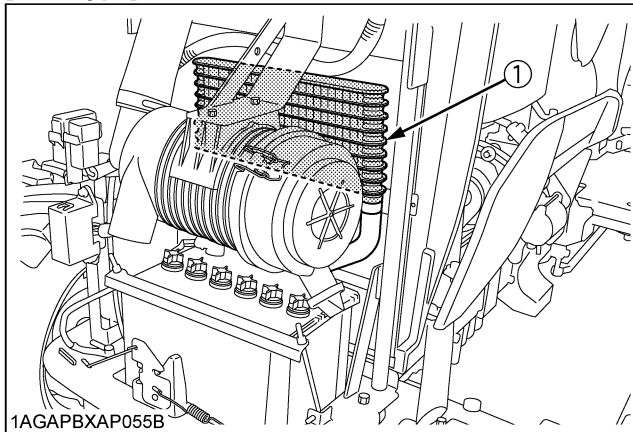

(1) Oil cooler

IMPORTANT :

- Grill and screen must be clean from debris to prevent engine from overheating and to allow good air intake for the air cleaner.

■ Checking Brake Pedals and Clutch Pedal



WARNING

To avoid personal injury:

- Be sure brake pedals have equal adjustment when using locked together. Incorrect or unequal brake pedal adjustment can cause the tractor to swerve or roll-over.

1. Inspect the brake and clutch pedals for free travel, and smooth operation.
2. Adjust if incorrect measurement is found: (See "Adjusting Clutch Pedal" and "Adjusting Brake Pedal" in "EVERY 100 HOURS" in "PERIODIC SERVICE" section.)

■ Checking Gauges, Meter and Easy Checker(TM)

1. Inspect the instrument panel for broken gauge(s), meter(s) and Easy Checker(TM) lamps.
2. Replace if broken.

■ Checking Head Light, Turn Signal / Hazard Light etc.

1. Inspect the lights for broken bulbs and lenses.
2. Replace if broken.

■ Checking Seat Belt and ROPS

1. Always check condition of seat belt and ROPS attaching hardware before operating tractor.
2. Replace if damaged.

■ Checking and Cleaning of Electrical Wiring and Battery Cables



CAUTION

To avoid personal injury:

- A loosened terminal or connector, or damaged wire may affect the performance of electrical components or cause short circuits. Leakage of electricity could result in a fire hazard, a dead battery or damage to electrical components.
- Replace damaged wires or connections promptly.
- If a fuse blows soon after replacement, **DO NOT USE A LARGER THAN RECOMMENDED FUSE OR BYPASS THE FUSE SYSTEM.**
- Many wiring connections are protected by waterproof plugs, plug and unplug these connections carefully and make sure they are sealed correctly after assembly.
- Accumulation of dust, chaff and spilled fuel deposits around the battery, electrical wiring, engine or exhaust system are fire hazards. **CLEAN THESE AREAS BEFORE STARTING WORK.**

To avoid premature electrical malfunctions **DO NOT APPLY** high pressure water directly to battery, wiring, connectors, electrical components or instrument panel.

Inspect the following regularly:

1. Check wiring for chafed or cracked insulation.
2. Check wiring harness clamps. Replace if necessary.
3. Check connectors and terminals for looseness, contamination or overheated (discolored) connections.
4. Check instrument panel for correct operation of switches and gauges.

Consult your KUBOTA Dealer regarding maintenance, diagnosis and repair.

■ Checking Movable Parts

If any of the movable parts, such as levers and pedals, is not smoothly moved because of rust or anything sticky, do not attempt to force it into motion.

In the above case, remove the rust or the sticky thing, and apply oil or grease on the relevant spot.

Otherwise, the machine may get damaged.

EVERY 50 HOURS

■ Lubricating Grease Fittings

Apply a small amount of multipurpose grease to the following points every 50 hours:

If you operated the machine in extremely wet and muddy conditions, lubricate grease fittings more often.

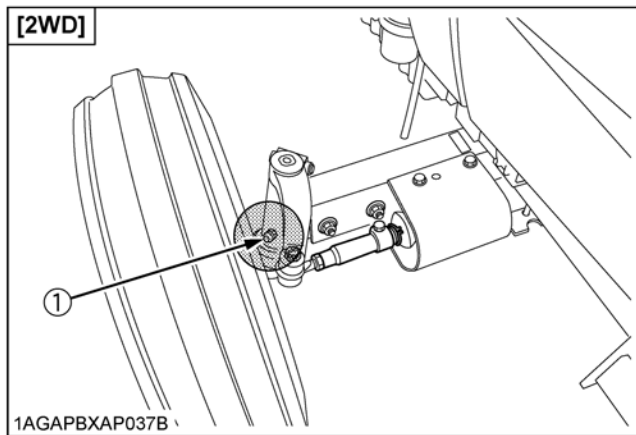

(1) Grease fitting (Knuckle shaft)[RH, LH]

When apply a grease to both front axle supports, apply a grease until grease overflows from breather port.

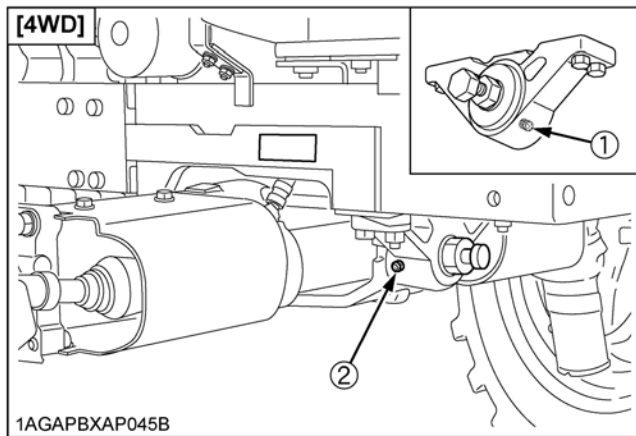

(1) Grease fitting (Front axle support)
(2) Breather

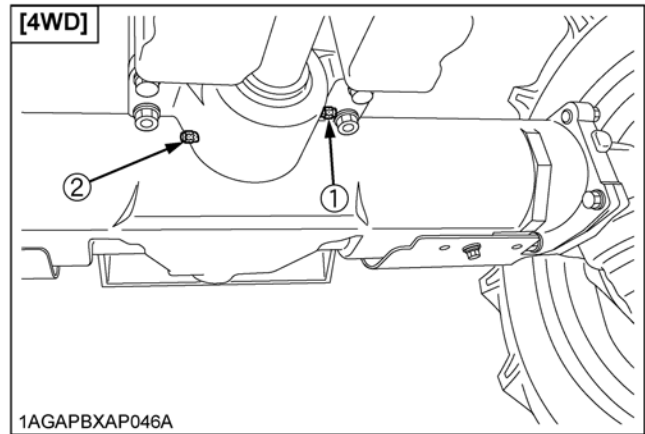

(1) Grease fitting (Front axle support)
(2) Breather

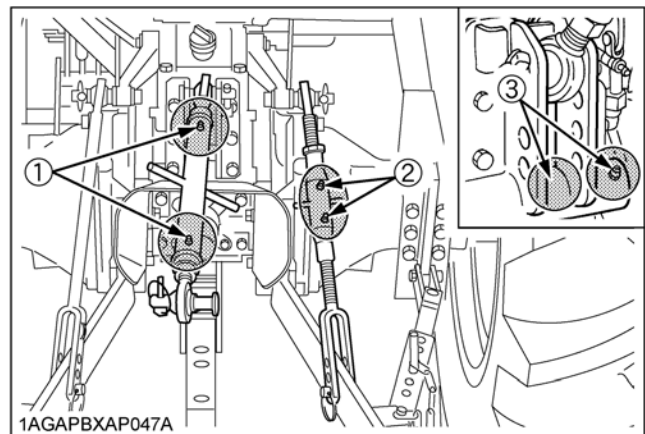

(1) Grease fitting (Top link)
(2) Grease fitting (Lifting rod) [RH]
(3) Grease fitting (Top link bracket)(with draft control)(if equipped)

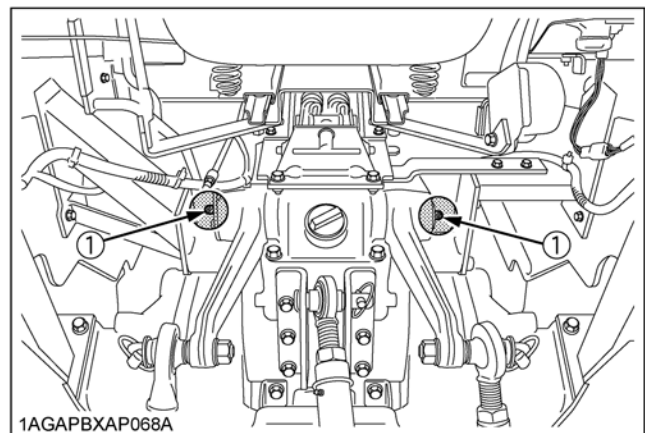

(1) Grease fitting (Hydraulic arm axle)

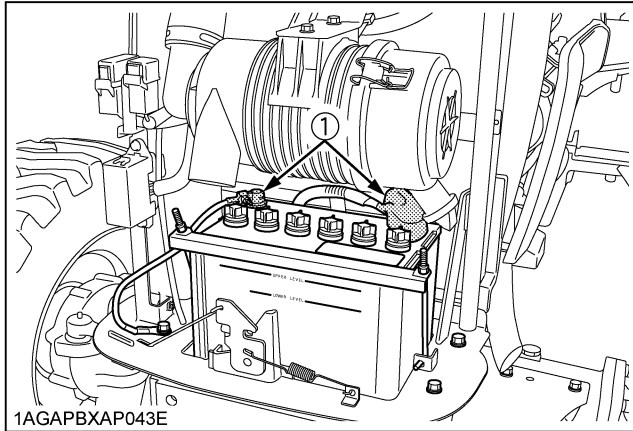

(1) Battery terminals

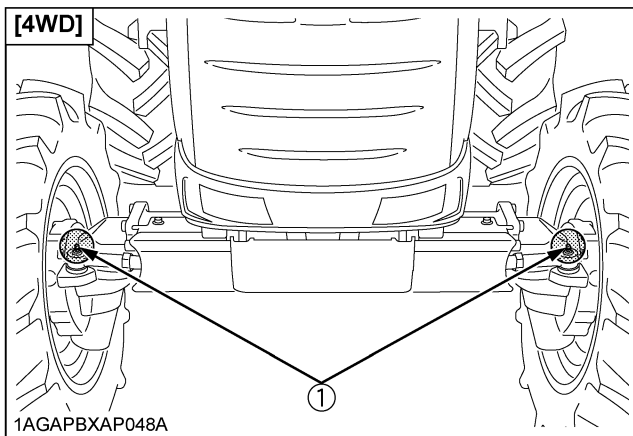

(1) Grease fitting (Tie-rod ends)

■ Checking Engine Start System



CAUTION

To avoid personal injury:

- Do not allow anyone near the tractor while testing.
- If the tractor does not pass the test, do not operate the tractor.

◆ Preparation before testing.

1. Place all control levers in the "NEUTRAL" position.
2. Set the parking brake and stop the engine.

[Manual Transmission Type]

◆ Test: Switch for the shuttle shift lever.

1. Sit on the operator's seat
2. Shift the shuttle shift lever to the forward or reverse position.
3. Depress the clutch pedal fully.
4. Disengage the PTO clutch control switch or lever.
5. Turn the key to "START" position.
6. The engine must not crank.
7. If it cranks, consult your local KUBOTA Dealer for this service.

◆ Test: Switch for the PTO clutch control switch or lever.

1. Sit on the operator's seat.
2. Engage the PTO clutch control switch or lever.
3. Depress the clutch pedal fully.
4. Shift the shuttle shift lever to the neutral position.
5. Turn the key to "START" position.
6. The engine must not crank.
7. If it cranks, consult your local KUBOTA Dealer for this service.

◆ Test: Switch for the operator's seat

1. Sit on the operator's seat.
2. Start the engine.
3. Engage the PTO clutch control switch or lever.
4. Stand up. (Do not get off the machine.)
5. The engine must shut off after approximately 1 second.
6. If it does not stop, consult your local KUBOTA Dealer for this service.

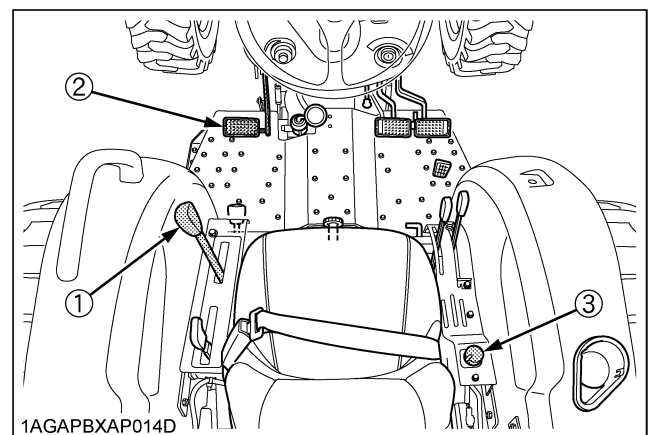

(1) Shuttle shift lever

(2) Clutch pedal

(3) PTO clutch control switch

[HST Type]

◆ Test: Switch for the speed control pedal.

1. Sit on the operator's seat.
2. Depress the speed control pedal to the desired direction.
3. Depress the clutch pedal fully.
4. Disengage the PTO clutch control switch or lever.
5. Turn the key to "START" position.
6. The engine must not crank.
7. If it cranks, consult your local KUBOTA Dealer for this service.

◆ Test: Switch for the PTO clutch control switch or lever.

1. Sit on the operator's seat.
2. Engage the PTO clutch control switch or lever.
3. Depress the clutch pedal fully.
4. Place the speed control pedal in neutral position.
5. Turn the key to "START" position.

6. The engine must not crank.
7. If it cranks, consult your local KUBOTA Dealer for this service.

◆ **Test: Switch for the operator's seat**

1. Sit on the operator's seat.
2. Start the engine.
3. Engage the PTO clutch control switch or lever.
4. Stand up. (Do not get off the machine.)
5. The engine must shut off after approximately 1 second.
6. If it does not stop, consult your local KUBOTA Dealer for this service.

◆ **Test: Switch for the clutch pedal.**

1. Sit on the operator's seat.
2. Disengage the PTO clutch control switch or lever.
3. Place the speed control pedal in neutral position.
4. Release the clutch pedal.
5. Turn the key to "START" position.
6. The engine must not crank.
7. If it cranks, consult your local KUBOTA Dealer for this service.

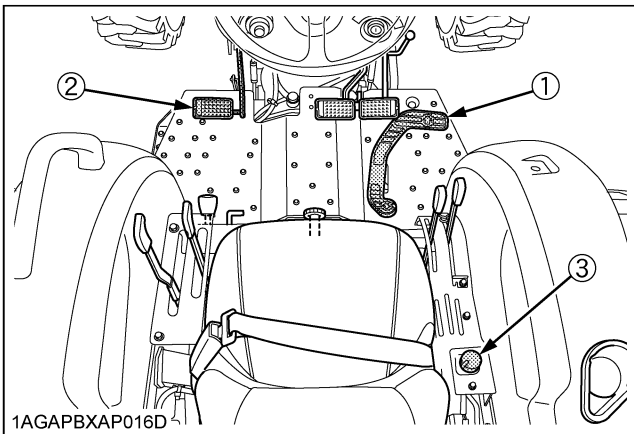

- (1) Speed control pedal
- (2) Clutch pedal
- (3) PTO clutch control switch

■ **Checking Wheel Bolt Torque**



CAUTION

To avoid personal injury:

- Never operate tractor with a loose rim, wheel, or axle.
- Any time bolts and nuts are loosened, retighten to specified torque.
- Check all bolts and nuts frequently and keep them tight.

Check wheel bolts and nuts regularly especially when new. If they are loose, tighten them as follows.

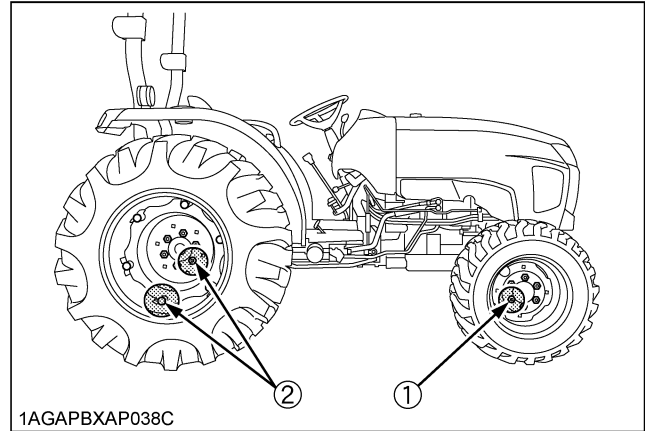

- (1) 124.0 to 147.0 N-m (12.6 to 15.0 kgf-m, 91.5 to 108.4 ft-lbs)
- (2) 196.0 to 225.0 N-m (20.0 to 23.0 kgf-m, 144.6 to 166.0 ft-lbs)

■ **Checking Tie-rod Dust Cover**

1. Check to see that dust covers are not damaged.
2. If dust covers are damaged, consult local KUBOTA Dealer for this service.

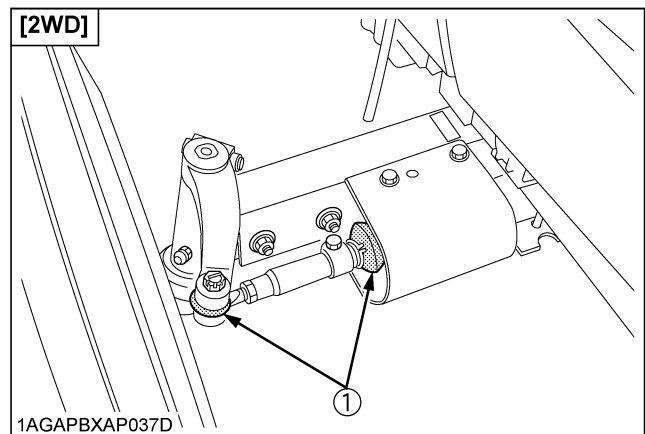
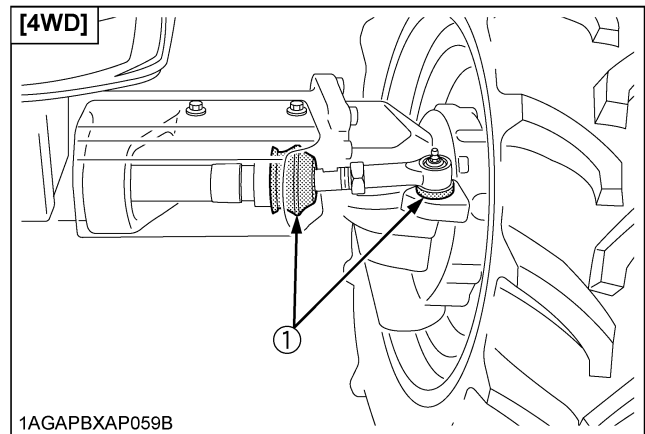

- (1) Dust cover

IMPORTANT :

- If dust covers are cracked, water and dust invade into tie-rod and it will be early wear.

EVERY 100 HOURS

■ Cleaning Air Cleaner Primary Element

1. Remove the air cleaner cover and primary element.
2. Clean the primary element:
 - (1) When dry dust adheres to the element, blow compressed air from the inside, turning the element. Pressure of compressed air must be under 205 kPa (2.1 kgf/cm², 30 psi).
 - (2) When carbon or oil adheres to the element, soak the element in detergent for 15 minutes then wash it several times in water, rinse with clean water and dry it naturally. After element is fully dried, inspect inside of the element with a light and check if it is damaged or not.
3. Replace air cleaner primary element:
Once yearly or after every sixth cleaning, whichever comes first.

NOTE :

- Check to see if the evacuator valve is blocked with dust.

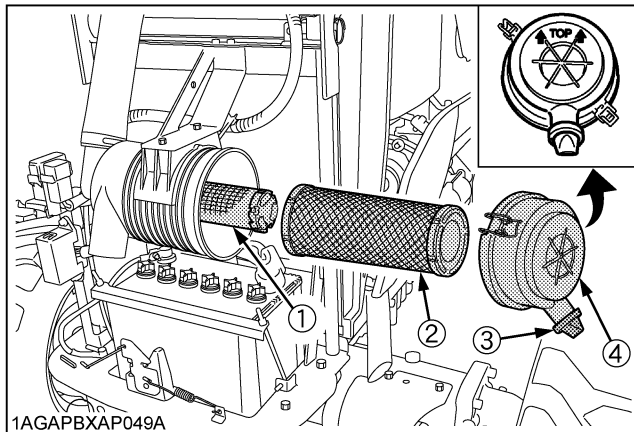

- (1) Secondary (safety) element
- (2) Primary element
- (3) Evacuator valve
- (4) Cover

IMPORTANT :

- The air cleaner uses a dry element, never apply oil.
- Do not run the engine with filter element removed.
- Be sure to refit the cover with the arrow ↑ (on the rear of cover) upright. If the cover is improperly fitted, evacuator valve will not function and dust will adhere to the element.
- Do not touch the secondary element except in cases where replacing is required.
(See "Replacing Air Cleaner Secondary Element" in "EVERY 1 YEAR" in "PERIODIC SERVICE" section.)

◆ Evacuator Valve

Open the evacuator valve once a week under ordinary conditions - or daily when used in a dusty place - to get rid of large particles of dust and dirt.

■ Cleaning Fuel Filter

This job should not be done in the field, but in a clean place.

1. Close the fuel cock.
2. Unscrew the screw ring and remove the filter bowl, and rinse the inside with kerosene.
3. Take out the element and dip it in the kerosene to rinse.
4. After cleaning, reassemble the fuel filter, keeping out dust and dirt.
5. Bleed the fuel system.
(See "Bleeding Fuel System" in "SERVICE AS REQUIRED" in "PERIODIC SERVICE" section.)

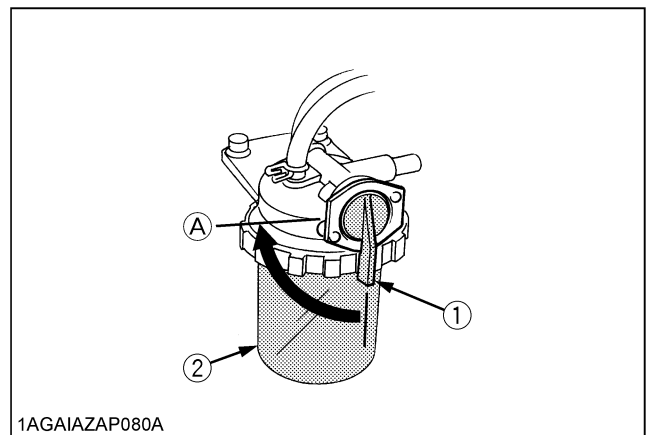

- (1) Fuel cock
- (A) "CLOSE"
- (2) Fuel filter bowl

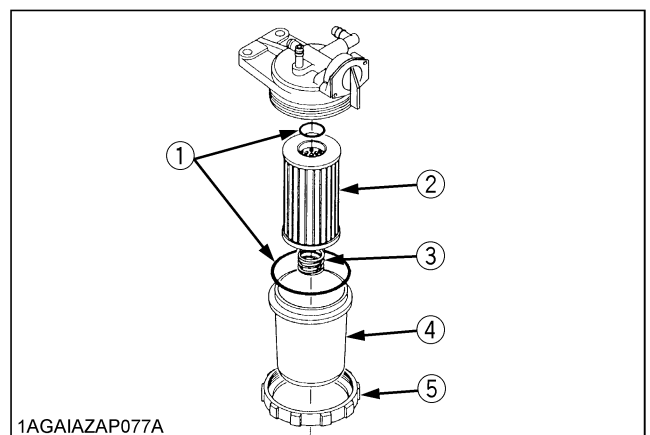

- (1) O ring
- (2) Filter element
- (3) Spring
- (4) Filter bowl
- (5) Screw ring

IMPORTANT :

- If dust and dirt enters the fuel system, the fuel pump and injection nozzles are subject to premature wear. To prevent this, be sure to clean the fuel filter bowl and element periodically.

■ Adjusting Fan Belt Tension

⚠ CAUTION

To avoid personal injury:

- Be sure to stop the engine before checking belt tension.

Proper fan belt tension	A deflection is 12 mm (0.48 in.) when the belt is pressed (68.6 N [7 kgf, 15.4 lbs]) in the middle of the span.
-------------------------	---

1. Stop the engine and remove the key.
2. Apply moderate thumb pressure to belt between pulleys.
3. If tension is incorrect, loosen the alternator mounting bolts and, using a lever placed between the alternator and the engine block, pull the alternator out until the deflection of the belt falls within acceptable limits.
4. Replace fan belt if it is damaged.

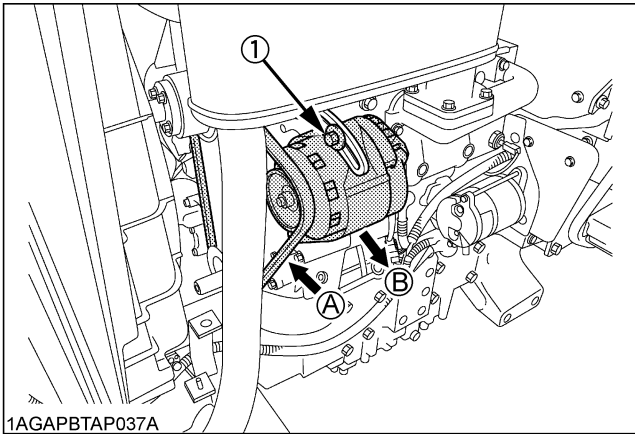

(1) Bolt

(A) Check the belt tension
(B) To tighten

■ Checking Fuel Line

1. Check to see that all lines and hose clamps are tight and not damaged.
2. If hoses and clamps are found worn or damaged, replace or repair them at once.

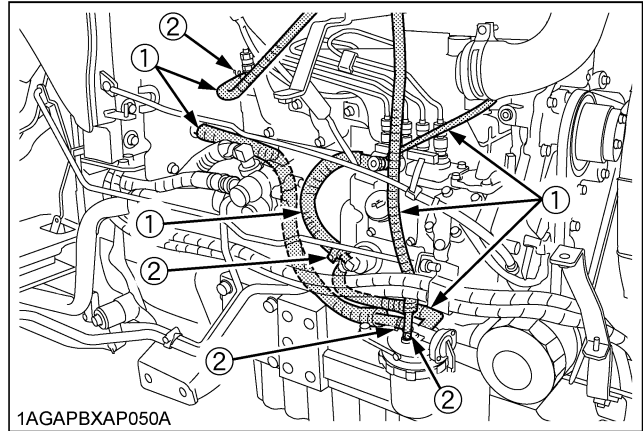

1AGAPBXAP050A

(1) Fuel lines
(2) Clamp bands

NOTE :

- If the fuel line is removed, be sure to properly bleed the fuel system.
(See "Bleeding Fuel System" in "SERVICE AS REQUIRED" in "PERIODIC SERVICE" section.)

■ Adjusting Clutch Pedal

Proper clutch pedal free travel	20 to 30 mm (0.8 to 1.2 in.) on the pedal
---------------------------------	---

◆ Adjusting procedure

1. Stop the engine and remove the key.
2. Slightly depress the clutch pedal and measure free travel at the top of pedal stroke.
3. If adjustment is needed, loosen the lock nut and turn the turnbuckle to adjust the rod length within acceptable limits.
4. Retighten the lock nut.

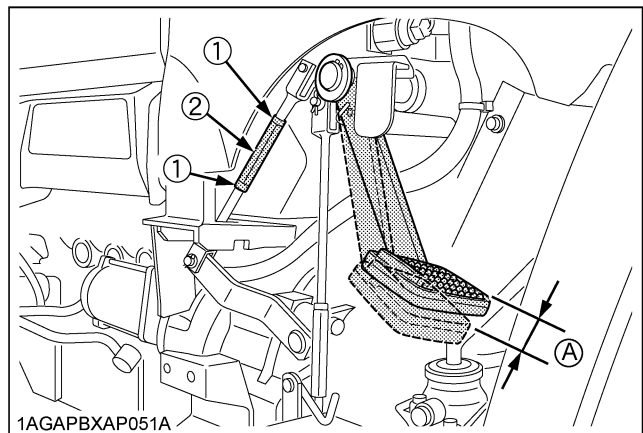

1AGAPBXAP051A

(1) Lock nut
(2) Turnbuckle

(A) "FREE TRAVEL"

■ Adjusting Brake Pedal

⚠ CAUTION

To avoid personal injury:

- Stop the engine and chock the wheels before checking brake pedal.

Proper brake pedal free travel	15 to 20 mm (0.6 to 0.8 in.) on the pedal
	Keep the free travel in the right and left brake pedals equal.

1. Release the parking brake.
2. Slightly depress the brake pedals and measure free travel at the top of pedal stroke.
3. If adjustment is needed, loosen the lock nut and turn the turnbuckle to adjust the rod length within acceptable limits.
4. Retighten the lock nut.

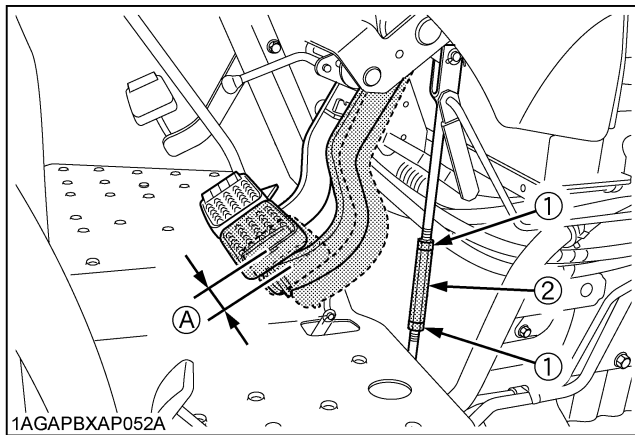

(1) Lock nut
(2) Turnbuckle

(A) "FREE TRAVEL"

■ Checking Battery Condition

⚠ DANGER

To avoid the possibility of battery explosion:

For the refillable type battery, follow the instructions below.

- Do not use or charge the refillable type battery if the fluid level is below the LOWER (lower limit level) mark. Otherwise, the battery component parts may prematurely deteriorate, which may shorten the battery's service life or cause an explosion. Check the fluid level regularly and add distilled water as required so that the fluid level is between the UPPER and LOWER levels.

⚠ CAUTION

To avoid personal injury:

- Never remove the battery cap while the engine is running.
- Keep electrolyte away from eyes, hands and clothes. If you are splattered with it, wash it away completely with water immediately and get medical attention.
- Keep open sparks and flames away from the battery at all times. Hydrogen gas mixed with oxygen becomes very explosive.
- Wear eye protection and rubber gloves when working around battery.

Mishandling the battery shortens the service life and adds to maintenance costs.

The original battery is maintenance free, but needs some servicing. If the battery is weak, the engine will be difficult to start and the lights will be dim. It is important to check the battery periodically.

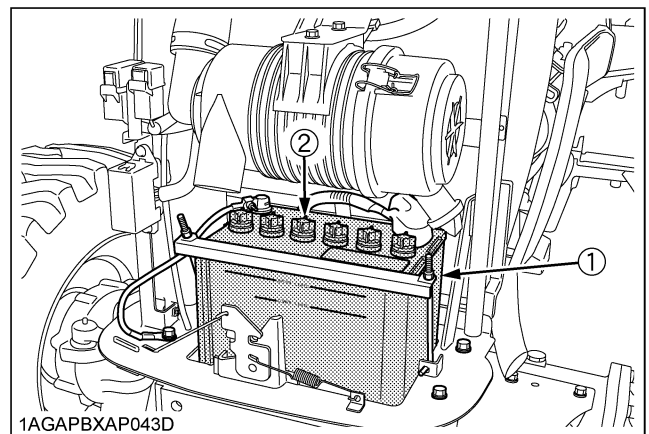

(1) Battery
(2) Vent cap

◆ Battery Charging

CAUTION

To avoid personal injury:

- When the battery is being activated, hydrogen and oxygen gases in the battery are extremely explosive. Keep open sparks and flames away from the battery at all times, especially when charging the battery.
- When charging the battery, ensure the vent caps are securely in place. (if equipped)
- When disconnecting the cable from the battery, start with the negative terminal first. When connecting the cable to the battery, start with the positive terminal first.
- Never check battery charge by placing a metal object across the posts. Use a voltmeter or hydrometer.

1. Make sure each electrolyte level is to the bottom of vent wells, if necessary add distilled water in a well-ventilated area.

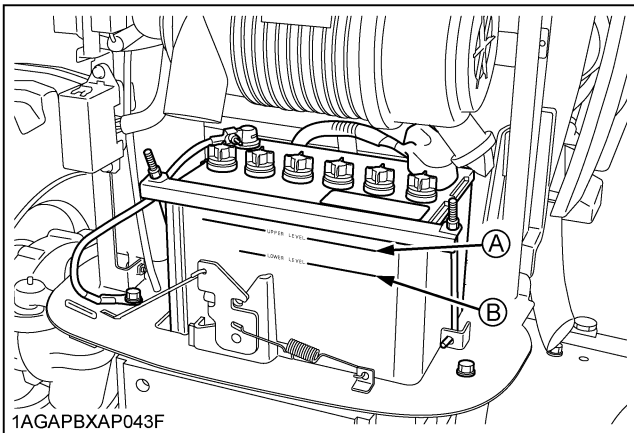

(A) Highest level

(B) Lowest level

2. The water in the electrolyte evaporates during recharging. Liquid shortage damages the battery. Excessive liquid spills over and damages the tractor body.
3. To slow charge the battery, connect the battery positive terminal to the charger positive terminal and the negative to the negative, then recharge in the standard fashion.
4. A boost charge is only for emergencies. It will partially charge the battery at a high rate and in a short time. When using a boost-charged battery, it is necessary to recharge the battery as early as possible. Failure to do this will shorten the battery's service life.
5. When the specific gravity of electrolyte is between 1.27 and 1.29, the charging is completed.
6. When exchanging an old battery for a new one, use battery of equal specification shown in **table 1**.

[TABLE 1]

Battery Type	Volts (V)	Capacity at 5H.R	Reserve at (min)	Cold Cranking Amps	Normal Charging Rate(A)
80D-26R	12	55	133	582	6.5

◆ Direction for Storage

1. When storing the tractor for long periods of time, remove the battery from tractor, adjust the electrolyte to the proper level and store in a dry place out of direct sunlight.
2. The battery self-discharges while it is stored. Recharge it once every three months in hot seasons and once every six months in cold seasons.

EVERY 200 HOURS

■ Replacing Engine Oil Filter

CAUTION

To avoid personal injury:

- Be sure to stop the engine before changing the oil filter cartridge.
- Allow engine to cool down sufficiently, oil can be hot and can burn.

1. Remove the oil filter.
2. Put a film of clean engine oil on the rubber seal of the new filter.
3. Tighten the filter quickly until it contacts the mounting surface. Tighten filter by hand an additional 1/2 turn only.
4. After the new filter has been replaced, the engine oil normally decreases a little. Make sure that the engine oil does not leak through the seal and be sure to check the oil level on the dipstick. Then, replenish the engine oil up to the prescribed level.

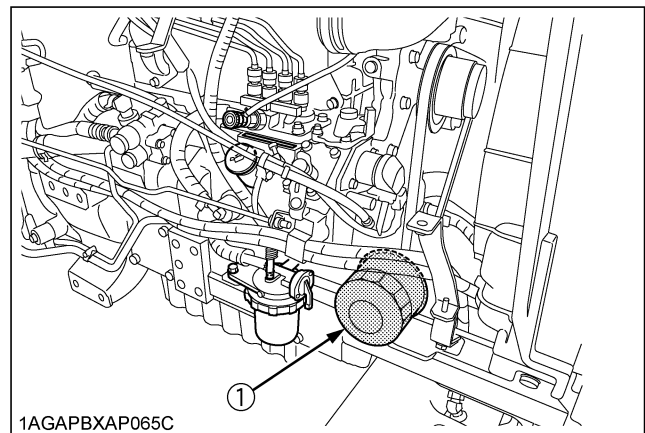

(1) Engine oil filter

IMPORTANT :

- To prevent serious damage to the engine, use only a KUBOTA genuine filter.

■ Changing Engine Oil

CAUTION

To avoid personal injury:

- Be sure to stop the engine before changing the oil.
- Allow engine to cool down sufficiently, oil can be hot and can burn.

1. To drain the used oil, remove the drain plug at the bottom of the engine and drain the oil completely into the oil pan.

All the used oil can be drained out easily when the engine is still warm.

2. After draining reinstall the drain plug.
 3. Fill with the new oil up to the upper notch on the dipstick.
- (See "LUBRICANTS" in "MAINTENANCE" section.)

Oil capacity with filter	7.6 L (8.0 U.S.qts.)
--------------------------	----------------------

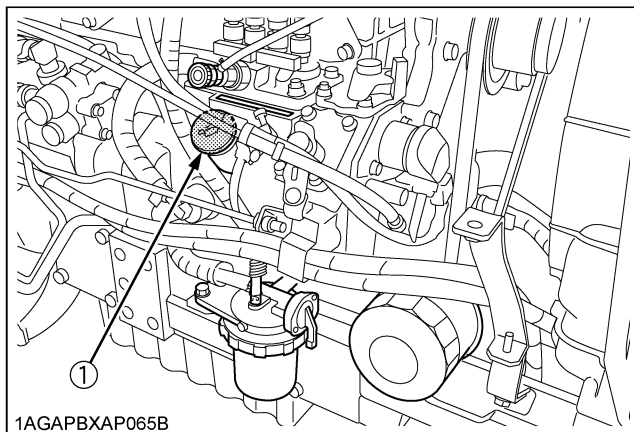

(1) Oil inlet

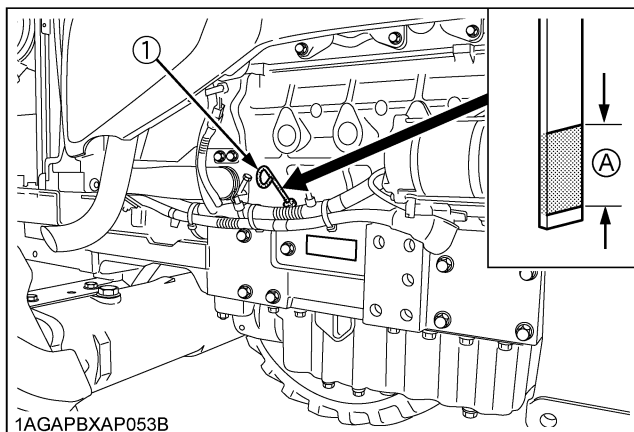

(1) Dipstick

(A) Oil level is acceptable within this range

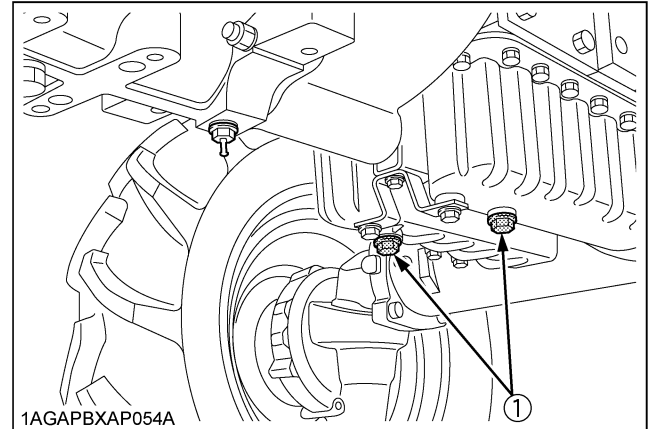

(1) Drain plug

■ Replacing Transmission Oil Filter [HST Type]

CAUTION

To avoid personal injury:

- Be sure to stop the engine before changing the oil filter cartridge.
- Allow engine to cool down sufficiently, oil can be hot and can burn.

1. Place the oil pan underneath the transmission oil filter and remove the filter. Do not remove the hydraulic oil filter. Otherwise, the oil comes out.

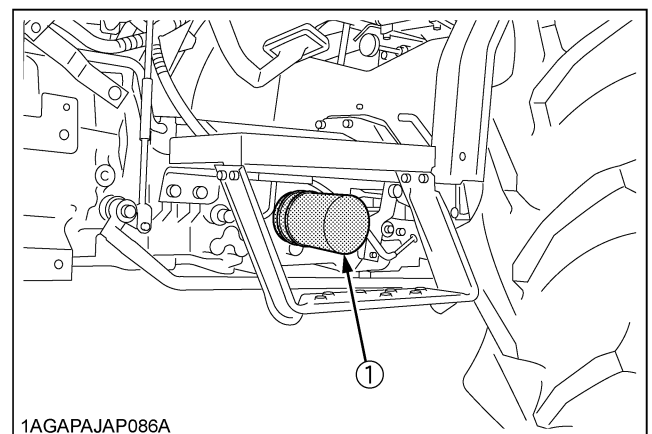

(1) Transmission oil filter [HST Type]

2. Put a film of clean transmission oil on the rubber seal of the new filter.
3. Quickly tighten the filter until it contacts the mounting surface, then, with a filter wrench, tighten it an additional 1 turn only.
4. After the new filter has been replaced, fill the transmission oil up to the upper notch on the dipstick.

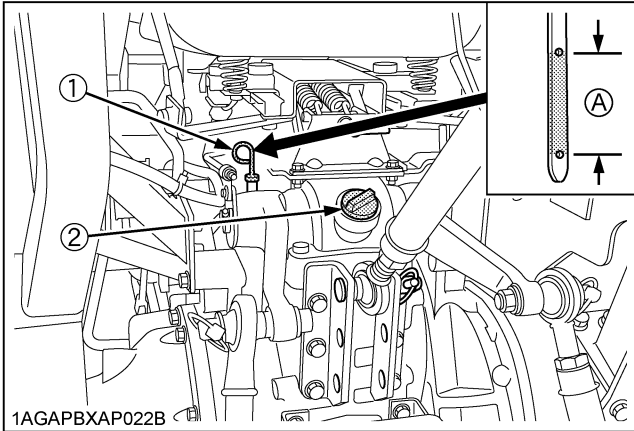

(1) Dipstick (A) Oil level is acceptable within this range.
 (2) Oil inlet

5. After running the engine for a few minutes, stop the engine and check the oil level again, add oil to the prescribed level.
6. Make sure that the transmission fluid doesn't leak past the seal on the filter.

IMPORTANT :

- To prevent serious damage to the hydraulic system, use only a KUBOTA genuine filter.
- Do not operate the tractor immediately after changing the transmission fluid.
 Run the engine at medium speed for a few minutes to prevent damage to the transmission.

■ Checking Radiator Hose and Clamp

Check to see if radiator hoses are properly fixed every 200 hours of operation or six months, whichever comes first.

1. If hose clamps are loose or water leaks, tighten bands securely.
2. Replace hoses and tighten hose clamps securely, if radiator hoses are swollen, hardened or cracked.

Replace hoses and hose clamps every 2 years or earlier if checked and found that hoses are swollen, hardened or cracked.

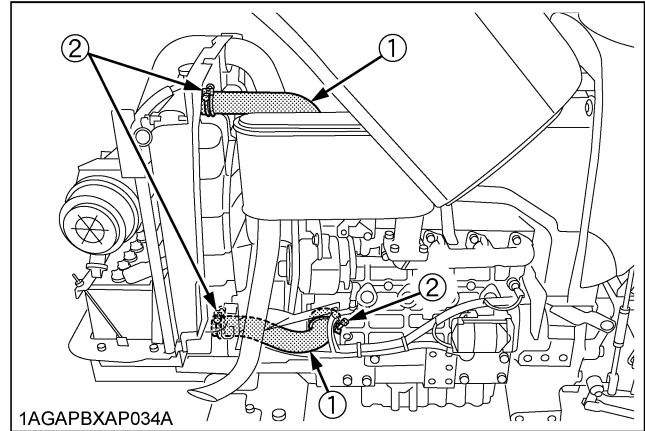

(1) Radiator hoses
 (2) Clamp bands

◆ Precaution at Overheating

Take the following actions in the event the coolant temperature is nearly or more than the boiling point, what is called "Overheating"

1. Park the tractor in a safe place and keep the engine unloaded idling.
2. Don't stop the engine suddenly, but stop it after about 5 minutes of unloaded idling.
3. Keep yourself well away from the machine for further 10 minutes or while the steam blows out.
4. Check that there are no dangers such as burns. Get rid of the causes of overheating according to the manual, see "TROUBLESHOOTING" section, and then, start again the engine.

■ Checking Oil Cooler Line

[HST Type]

1. Check to see that all lines and hose clamps are tight and not damaged.
2. If hoses and clamps are found worn or damaged, replace or repair them at once.

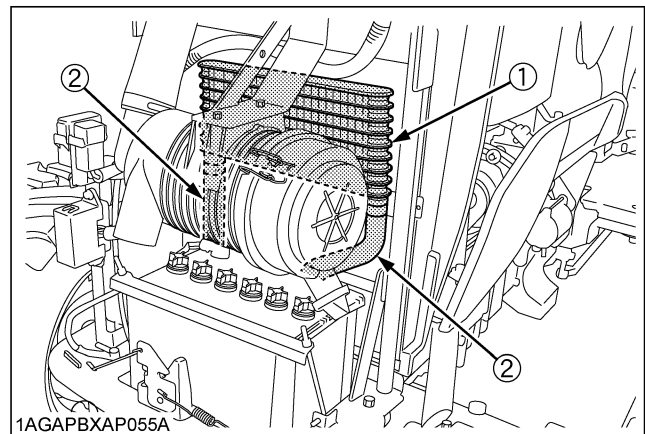

(1) Oil cooler
 (2) Oil cooler line

■ Checking Intake Air Line

1. Check to see that hoses and hose clamps are tight and not damaged.
2. If hoses and clamps are found worn or damaged, replace or repair them at once.

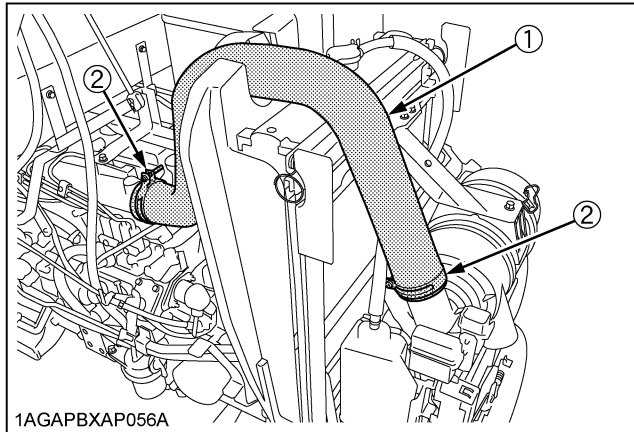

- (1) Hose
(2) Hose clamps

■ Checking Power Steering Line

1. Check to see that all lines and hose clamps are tight and not damaged.
2. If hoses and clamps are found worn or damaged, replace or repair them at once.

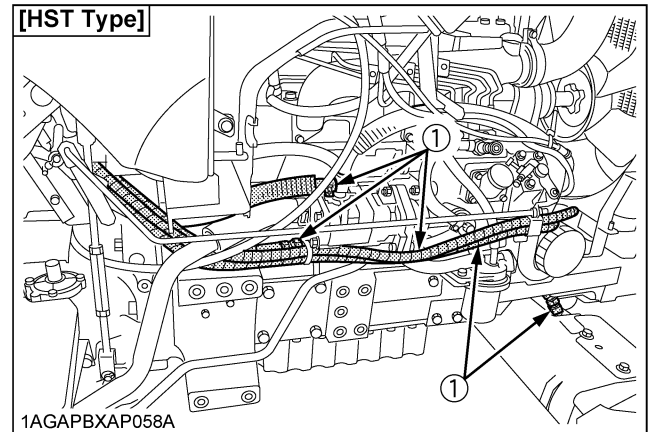
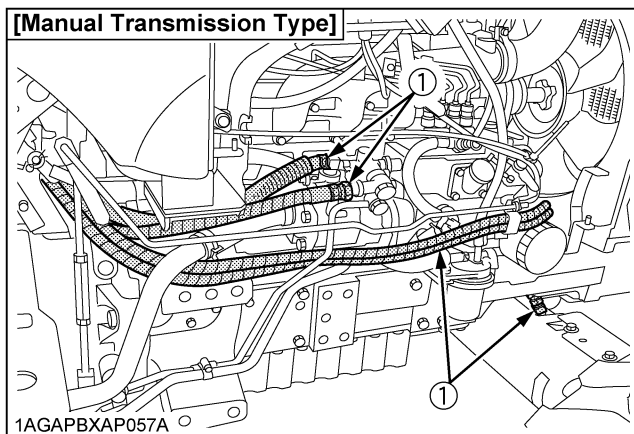

- (1) Power steering pressure hoses

■ Adjusting Toe-in

Proper toe-in	2 to 8 mm (0.08 to 0.31 in.)
---------------	------------------------------

1. Park tractor on a flat place.
2. Turn steering wheel so front wheels are in the straight ahead position.
3. Lower the implement, lock the park brake and stop the engine.
4. Measure distance between tire beads at front of tire, at hub height.
5. Measure distance between tire beads at rear of tire, at hub height.
6. Front distance should be shorter than rear distance. If not, adjust tie rod length.

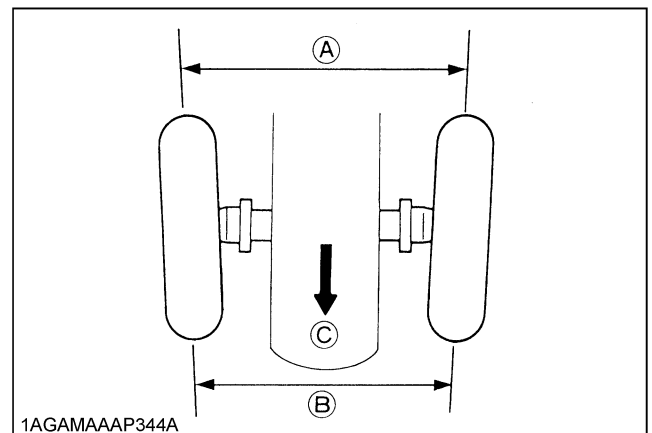

- (A) Wheel - to - wheel distance at rear
(B) Wheel - to - wheel distance at front
(C) "FRONT"

◆ **Adjusting procedure [2WD]**

1. Detach the snap ring.
2. Loosen the tie-rod nut.
3. Turn the tie-rod joint to adjust the rod length until the proper toe-in measurement is obtained.
4. Retighten the tie-rod nut.
5. Attach the snap ring of the tie-rod joint.

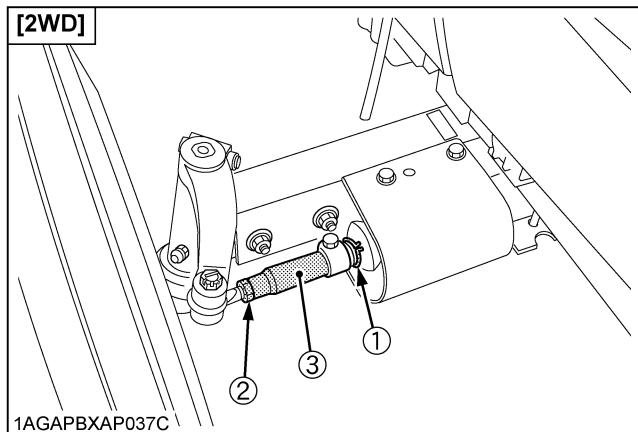

- (1) Snap ring
 (2) Tie-rod nut
 (83.3 to 88.2 N-m, 8.5 to 9.0 kgf-m, 61.4 to 65 ft-lbs)
 (3) Tie-rod joint

◆ **Adjusting procedures [4WD]**

1. Loosen the tie-rod nut.
2. Turn the tie-rod joint to adjust the rod length until the proper toe-in measurement is obtained.
3. Retighten the tie-rod nut.

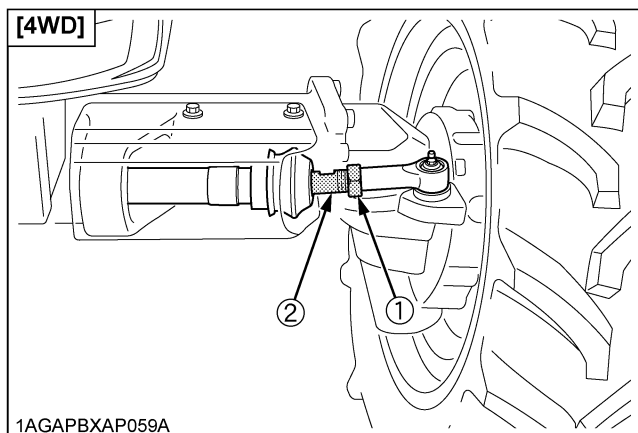

- (1) Tie-rod nut
 (167 to 196 N-m, 17 to 20 kgf-m, 123.2 to 144.6 ft-lbs)
 (2) Tie-rod joint

EVERY 400 HOURS

■ **Changing Transmission Fluid / Replacing Hydraulic Oil Filter**

◆ **Cleaning Magnetic Filter**



CAUTION

To avoid personal injury:

- Be sure to stop the engine before changing the oil filter cartridge.
- Allow engine to cool down sufficiently, oil can be hot and can burn.

1. Remove the drain plugs at the bottom of the transmission case and drain the oil completely into the oil pan.
2. After draining reinstall the drain plugs.

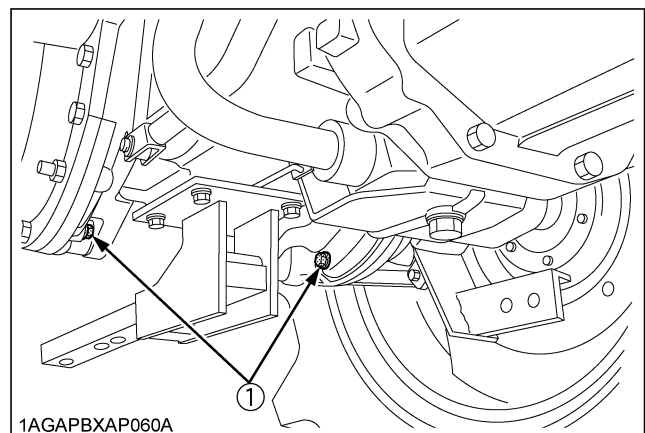

[Manual Transmission Type]

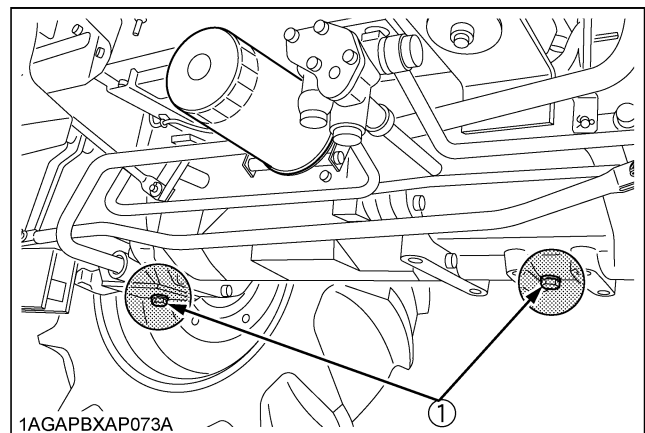

- (1) Drain plugs

[HST Type]

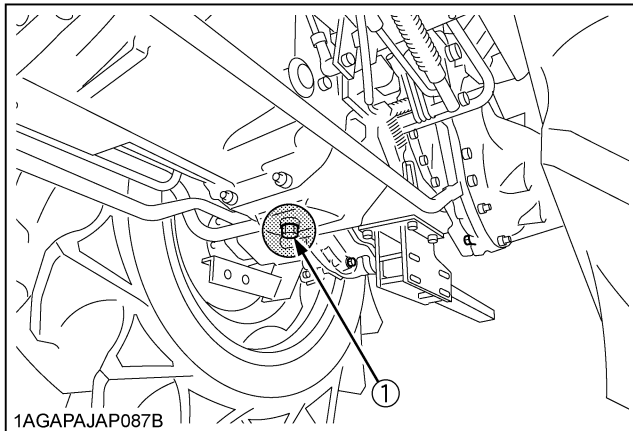

1AGAPAJAP087B

(1) Drain plug

3. Remove the oil filter.
4. Wipe off metal filings from the magnetic filter with a clean rag.

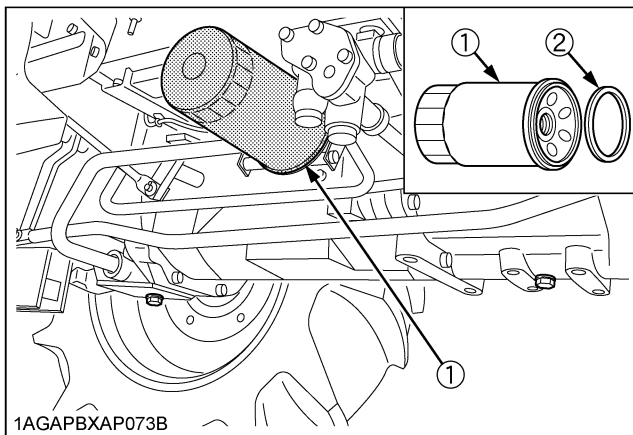

1AGAPBXAP073B

(1) Hydraulic oil filter
(2) Magnetic filter (Wipe off metal filings)

5. Put a film of clean transmission oil on the rubber seal of the new filter.
6. Quickly tighten the filter until it contacts the mounting surface, then tighten it by hand an additional 1/2 turn only.
7. Fill with the new KUBOTA SUPER UDT fluid up to the upper notch on the dipstick.
(See "LUBRICANTS" in "MAINTENANCE" section.)
8. After running the engine for a few minutes, stop the engine and check the oil level again, add oil to the prescribed level.
9. Make sure that the transmission fluid doesn't leak past the seal on the filter.

Oil capacity	40 L (10.6 U.S.gals.)
--------------	-----------------------

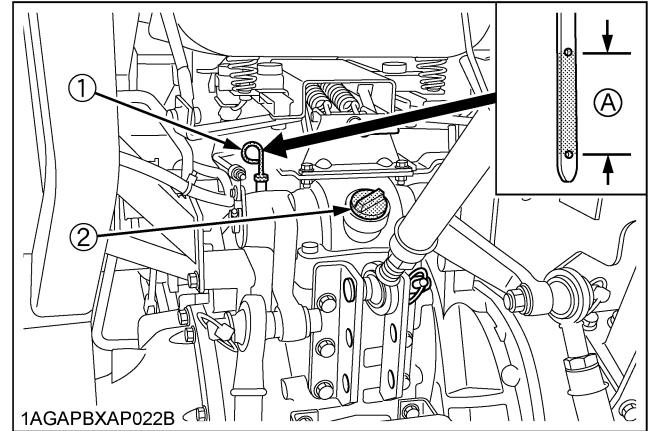

1AGAPBXAP022B

(1) Dipstick (A) Oil level is acceptable within this range.
(2) Oil inlet

IMPORTANT :

- To prevent serious damage to the hydraulic system, use only a KUBOTA genuine filter.
- Do not operate the tractor immediately after changing the transmission fluid.
Run the engine at medium speed for a few minutes to prevent damage to the transmission.

■ Changing Front Axle Case Oil [4WD]

1. To drain the used oil, remove the right and left drain plugs and filling plug at the front axle case and drain the oil completely into the oil pan.
2. After draining reinstall the drain plugs.
3. Remove the oil level check plug.
4. Fill with the new oil up to the check plug port.
(See "LUBRICANTS" in "MAINTENANCE" section.)
5. After filling reinstall the filling plug and check plug.

Oil capacity	6.5L (6.9 U.S.qts.)
--------------	---------------------

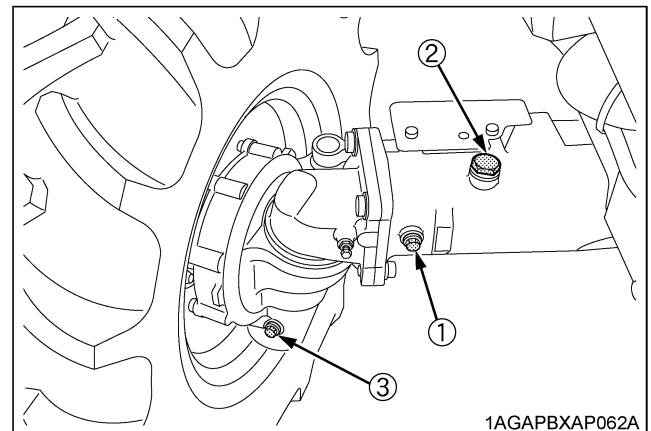

1AGAPBXAP062A

(1) Check plug
(2) Filling plug
(3) Drain plug

■ Replacing Fuel Filter Element

(See "Cleaning Fuel Filter" in "EVERY 100 HOURS" in "PERIODIC SERVICE" section.)

■ Lubricating Grease Fitting [2WD Model]

Detach the cover, and apply bearing grease.

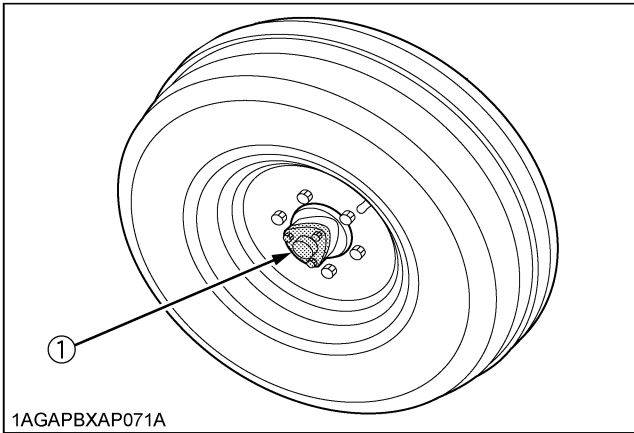

1AGAPBXAP071A

(1) Front wheel hub cover

EVERY 600 HOURS

■ Adjusting Front Axle Pivot

If the front axle pivot pin adjustment is not correct, front wheel vibration can occur causing vibration in the steering wheel.

◆ Adjusting procedure

Loosen the lock nut, screw-in the adjusting screw until seated, then tighten the screw with an additional 1/6 turn. Re-tighten the lock nut.

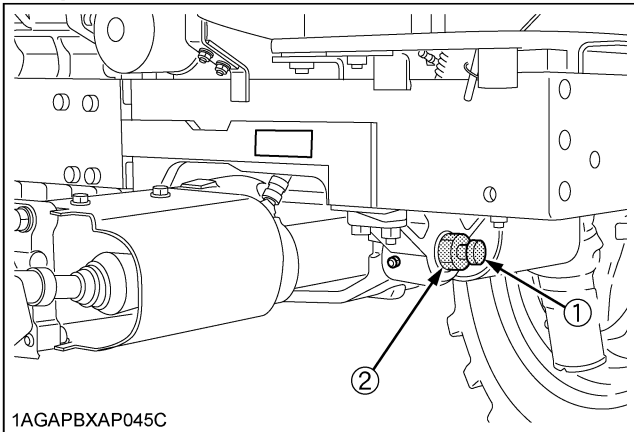

1AGAPBXAP045C

(1) Adjusting screw
(2) Lock nut

EVERY 800 HOURS

■ Adjusting Engine Valve Clearance

Consult your local KUBOTA Dealer for this service.

EVERY 1500 HOURS

■ Checking Fuel Injection Nozzle (Injection Pressure)

Consult your local KUBOTA Dealer for this service.

EVERY 3000 HOURS

■ Checking Injection Pump

Consult your local KUBOTA Dealer for this service.

EVERY 1 YEAR

■ Replacing Air Cleaner Primary Element and Secondary Element

(See "Cleaning Air Cleaner Primary Element" in "EVERY 100 HOURS" in "PERIODIC SERVICE" section.)

EVERY 2 YEARS

■ Flushing Cooling System and Changing Coolant

⚠ CAUTION

To avoid personal injury:

- Do not remove radiator cap while coolant is hot. When cool, slowly rotate cap to the first stop and allow sufficient time for excess pressure to escape before removing the cap completely.

1. Stop the engine, remove the key and let it cool down.
2. To drain the coolant, open the radiator drain plug and remove radiator cap. The radiator cap must be removed to completely drain the coolant.
3. After all coolant is drained, reinstall the drain plug.
4. Fill with clean soft water and cooling system cleaner.
5. Follow directions of the cleaner instruction.
6. After flushing, fill with clean soft water and anti-freeze until the coolant level is just below the radiator cap. Install the radiator cap securely.
7. Fill with coolant up to the "FULL" mark of recovery tank.
8. Start and operate the engine for few minutes.
9. Stop the engine, remove the key and let cool.
10. Check coolant level of recovery tank and add coolant if necessary.
11. Properly dispose of used coolant.

Coolant capacity	6.5 L (6.9 U.S.qts.)
------------------	----------------------

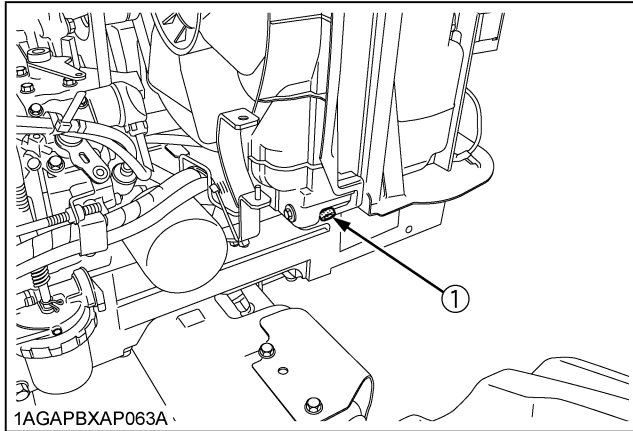

(1) Drain plug

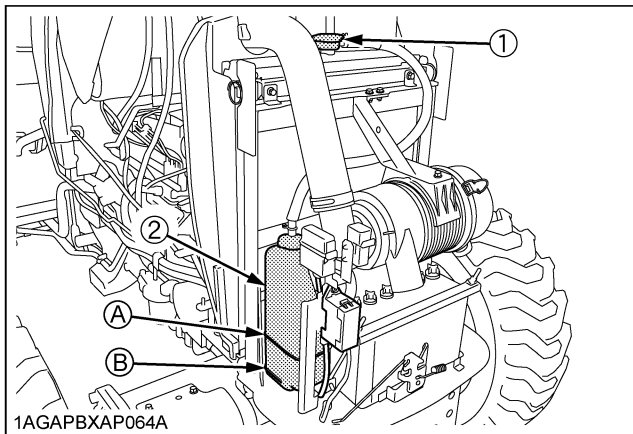

(1) Radiator cap
(2) Recovery tank

(A) "FULL"
(B) "LOW"

IMPORTANT :

- Do not start engine without coolant.
- Use clean, fresh soft water and anti-freeze to fill the radiator and recovery tank.
- When mixing the anti-freeze with water, the anti-freeze mixing ratio is 50 %.
- Securely tighten radiator cap. If the cap is loose or improperly fitted, water may leak out and the engine could overheat.

■ Anti-Freeze

⚠ CAUTION

To avoid personal injury:

- When using antifreeze, put on some protection such as rubber gloves (Antifreeze contains poison.).
- If should drink antifreeze, throw up at once and take medical attention.
- When antifreeze comes in contact with the skin or clothing, wash it off immediately.
- Do not mix different types of Antifreeze. The mixture can produce chemical reaction causing harmful substances.
- Antifreeze is extremely flammable and explosive under certain conditions. Keep fire and children away from antifreeze.
- When draining fluids from the engine, place some container underneath the engine body.
- Do not pour waste onto the grounds, down a drain, or into any water source.
- Also, observe the relevant environmental protection regulations when disposing of antifreeze.

If it freezes, coolant can damage the cylinders and radiator. If the ambient temperature falls below 0 °C (32 °F) or before a long-term storage, let out cooling water completely, or mix fresh water with long-life coolant and fill the radiator and recovery tank with the mixture.

1. Long-life coolant (hereafter LLC) comes in several types. Use ethylene glycol (EG) type for this engine.
2. Before employing LLC-mixed cooling water, fill the radiator with fresh water and empty it again. Repeat this procedure 2 or 3 times to clean up the inside.
3. Mixing the LLC
Put the LLC in cooling water in the percentage (%) for a target temperature. When mixing, stir it up well, and then fill into the radiator.
4. The procedure for the mixing of water and antifreeze differs according to the make of the antifreeze and the ambient temperature. Refer to SAE J1034 standard, more specifically also to SAE J814c.

IMPORTANT :

- When the antifreeze is mixed with water, the antifreeze mixing ratio must be less than 50%.

Vol % Anti-freeze	Freezing Point		Boiling Point*	
	°C	°F	°C	°F
40	-24	-12	106	222
50	-37	-34	108	226

- * At 1.013×10^5 Pa (760mmHg) pressure (atmospheric). A higher boiling point is obtained by using a radiator pressure cap which permits the development of pressure within the cooling system.
- 5. Adding the LLC
 - (1) Add only water if the mixture reduces in amount by evaporation.
 - (2) If there is a mixture leak, add the LLC of the same manufacturer and type in the same mixture percentage.
 - * Never add any long-life coolant of different manufacturer. (Different brands may have different additive components, and the engine may fail to perform as specified.)
- 6. When the LLC is mixed, do not employ any radiator cleaning agent. The LLC contains anticorrosive agent. If mixed with the cleaning agent, sludge may build up, adversely affecting the engine parts.
- 7. Kubota's genuine long-life coolant has a service life of 2 years. Be sure to change the coolant every 2 years.

NOTE :

- The above data represent industry standards that necessitate a minimum glycol content in the concentrated antifreeze.
- When the coolant level drops due to evaporation, add water only to keep the antifreeze mixing ratio less than 50%. In case of leakage, add antifreeze and water in the specified mixing ratio before filling in to the radiator.

■ Replacing Radiator Hose (Water pipes)

Replace the hoses and clamps.

(See "Checking Radiator Hose and Clamp" in "EVERY 200 HOURS" in "PERIODIC SERVICE" section.)

■ Replacing Power Steering Hose

Consult your local KUBOTA Dealer for this service.

■ Replacing Fuel Hose

Consult your local KUBOTA Dealer for this service.

■ Replacing Oil Cooler Line

[HST Type]

Consult your local KUBOTA Dealer for this service.

■ Replacing Intake Air Line

Consult your local KUBOTA Dealer for this service.

SERVICE AS REQUIRED**■ Bleeding Fuel System**

Air must be removed:

1. When the fuel filter or lines are removed.
2. When the tank is completely empty.
3. After the tractor has not been used for a long period of time.

◆ Bleeding procedure is as follows:

1. Fill the fuel tank with fuel, and open the fuel cock.

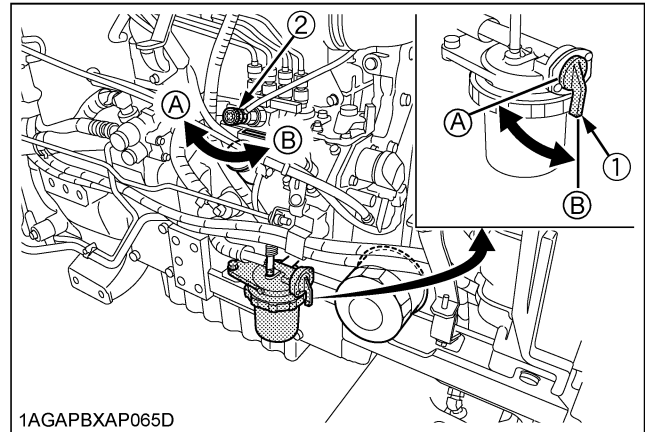

- | | |
|-------------------|-------------|
| (1) Fuel cock | (A) "CLOSE" |
| (2) Air vent cock | (B) "OPEN" |

2. Open the air vent cock on the fuel injection pump.
3. Start the engine and run for about 30 seconds, and then stop the engine.
4. Close the air vent cock.

IMPORTANT :

- Always close the air vent cock except for bleeding fuel lines. Otherwise, engine runs irregularly or stalls frequently.

■ Draining Clutch Housing Water

The tractor is equipped with split pin plug under the clutch housing.

After operating in rain, snow or tractor has been washed, water may get into the clutch housing. Check it by pushing in the split pin.

If water has entered into the clutch housing, remove the plug and drain the water, then install the plug again.

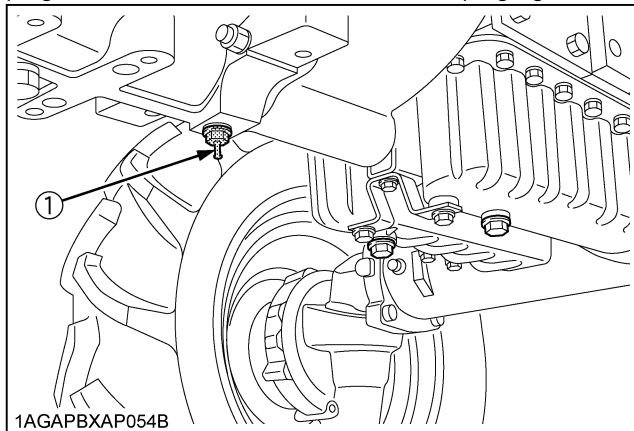

1AGAPBXAP054B

(1) Split pin plug

■ Replacing Fuse

The tractor electrical system is protected from potential damage by fuses.

A blown fuse indicates that there is an overload or short somewhere in the electrical system.

If any of the fuses should blow, replace with a new one of the same capacity.

IMPORTANT :

- Before replacing a blown fuse, determine why the fuse blew and make any necessary repairs. Failure to follow this procedure may result in serious damage to the tractor electrical system. Refer to the "TROUBLESHOOTING" section of this manual or your local KUBOTA Dealer for specific information dealing with electrical problems.

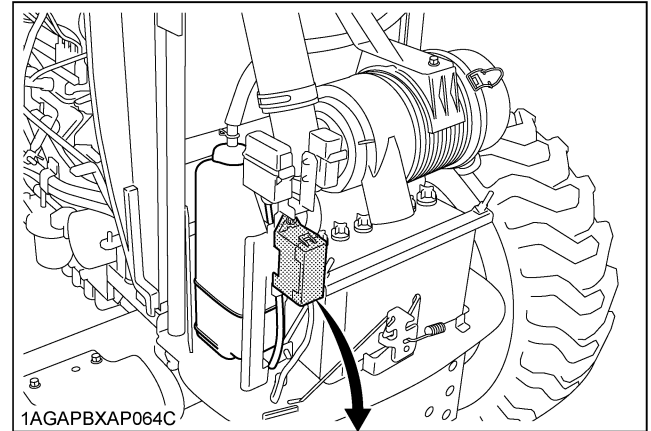

1AGAPBXAP064C

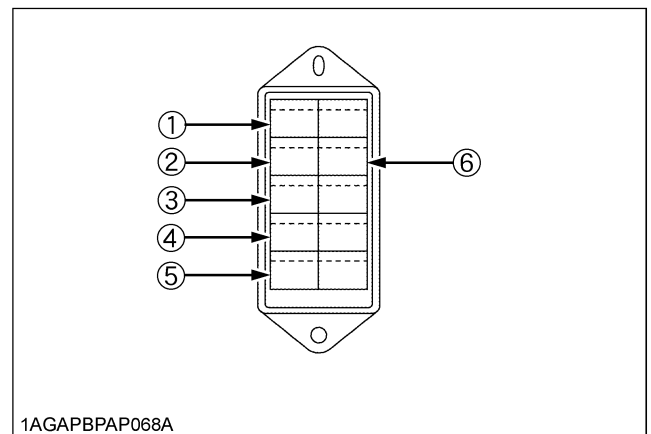

1AGAPBPAP068A

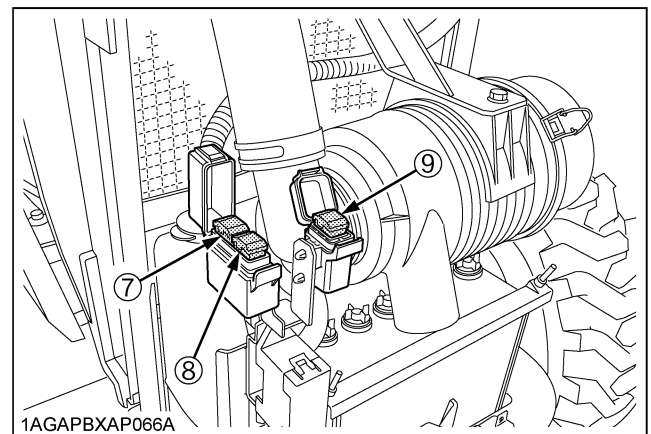

1AGAPBXAP066A

FUSE No.	CAPACITY(A)	Protected circuit
(1)	15	Hazard
(2)	5	Work light
(3)	5	Panel
(4)	10	Head light
(5)	5	OPC CONTROLLER
(6)	5	Glow lamp
(7)	50	Main
(8)	40	Key stop
(9)	40	Key switch

■ Replacing Light Bulb

Light	Capacity
Head light	25W / 25W
Tail light	5W
Turn signal / Hazard light (rear)	21W
Turn signal / Hazard light (front)	23W
Instrument panel light	1.7W

■ Replacing Head Lamp



CAUTION

To avoid personal injury:

- Be careful not to drop the bulb, hit anything against the lamp, apply excess force, and get the lamp scratched. If broken, glass may cause injury. Pay more attention to halogen lamps in particular, which have high pressure inside.
- Before replacing the lamp, be sure to turn off the light and wait until the bulb cools down, otherwise, you may get burned.

◆ Removing Bulb

1. Remove the rubber boot.
2. Turn the socket counterclockwise while pressing and remove it.
3. Remove the bulb.

◆ Attaching Bulb

1. Align (A) of the bulb with (B) of the lamp case and attach the bulb.
2. Align (C) of the socket with (D) of the lamp case and attach the socket.
3. Attach the rubber boot.

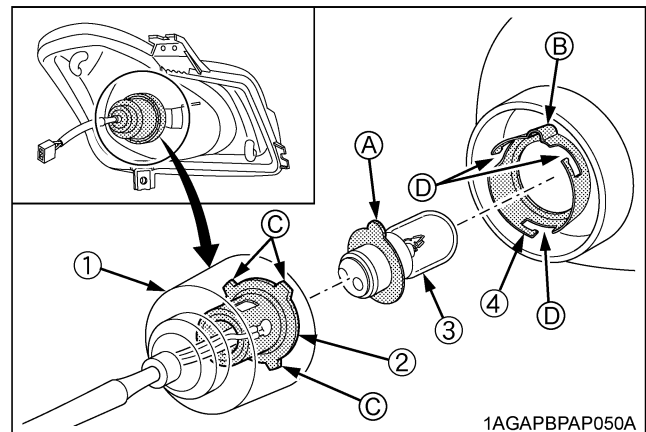

(1) Rubber boot

(2) Socket

(3) Bulb

(4) Lamp Case

(A) "Align to (B)"

(C) "Align to (D)"

IMPORTANT :

- Be sure to use a new bulb of the specified wattage.
- Never touch the bulb surface (glass) with bare hands. Fingerprints, for example, may break the bulb.

STORAGE



CAUTION

To avoid personal injury:

- Do not clean the machine while the engine is running.
- To avoid the danger of exhaust fume poisoning, do not operate the engine in a closed building without proper ventilation.
- When storing, remove the key from the key switch to avoid unauthorized persons from operating the tractor and getting injured.

TRACTOR STORAGE

If you intend to store your tractor for an extended period of time, follow the procedures outlined below.

These procedures will insure that the tractor is ready to operate with minimum preparation when it is removed from storage.

1. Check the bolts and nuts for looseness, and tighten if necessary.
2. Apply grease to tractor areas where bare metal will rust also to pivot areas.
3. Detach the weights from the tractor body.
4. Inflate the tires to a pressure a little higher than usual.
5. Change the engine oil and run the engine to circulate oil throughout the engine block and internal moving parts for about five minutes.
6. Keep the clutch disengaged. If the clutch is left engaged for a long period of time, the clutch plate may rust, making clutch disengagement impossible at the next operation.

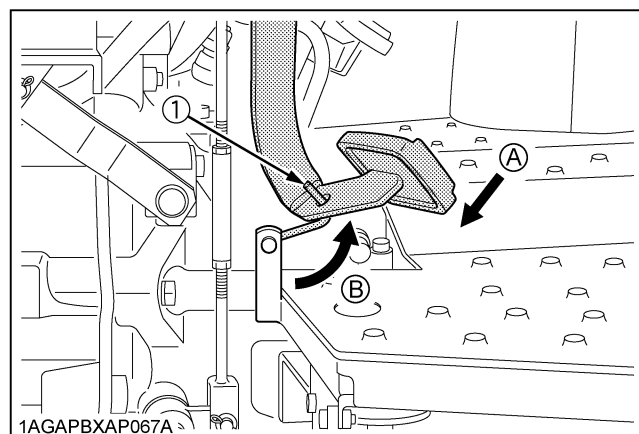

(1) Lock plate

(A) "DEPRESS"

(B) "HOOK TO LOCK"

7. With all implements lowered to the ground, coat any exposed hydraulic cylinder piston rods with grease.

8. Remove the battery from the tractor. Store the battery following the battery storage procedures. (See "Checking Battery Condition" in "EVERY 100 HOURS" in "PERIODIC SERVICE" section.)
9. Keep the tractor in a dry place where the tractor is sheltered from the elements. Cover the tractor.
10. Store the tractor indoors in a dry area that is protected from sunlight and excessive heat. If the tractor must be stored outdoors, cover it with a waterproof tarpaulin. Jack the tractor up and place blocks under the front and rear axles so that all four tires are off the ground. Keep the tires out of direct sunlight and extreme heat.

IMPORTANT :

- When washing the tractor, be sure to stop the engine. Allow sufficient time for the engine to cool before washing.
- Cover the tractor after the muffler and the engine have cooled down.

REMOVING THE TRACTOR FROM STORAGE

1. Check the tire air pressure and inflate the tires if they are low.
2. Jack the tractor up and remove the support blocks from under the front and rear axles.
3. Install the battery. Before installing the battery, be sure it is fully charged.
4. Check the fan belt tension.
5. Check all fluid levels (engine oil, transmission/hydraulic oil, engine coolant and any attached implements).
6. Start the engine. Observe all gauges. If all gauges are functioning properly and reading normal, move the tractor outside. Once outside, park the tractor and let the engine idle for at least five minutes. Shut the engine off and walk around tractor and make a visual inspection looking for evidence of oil or water leaks.
7. With the engine fully warmed up, release the parking brake and test the brakes for proper adjustment as you move forward. Adjust the brakes as necessary.

TROUBLESHOOTING

ENGINE TROUBLESHOOTING

If something is wrong with the engine, refer to the table below for the cause and its corrective measure.

Trouble		Cause	Countermeasure
Engine is difficult to start or won't start.		<ul style="list-style-type: none"> No fuel flow. 	<ul style="list-style-type: none"> Check the fuel tank and the fuel filter. Replace filter if necessary.
		<ul style="list-style-type: none"> Air or water is in the fuel system. 	<ul style="list-style-type: none"> Check to see if the fuel line coupler bolt and nut are tight. Bleed the fuel system (See "Bleeding Fuel System" in "SERVICE AS REQUIRED" in "PERIODIC SERVICE" section.)
		<ul style="list-style-type: none"> In winter, oil viscosity increases, and engine revolution is slow. 	<ul style="list-style-type: none"> Use oils of different viscosities, depending on ambient temperatures. Use engine block heater (Optional)
		<ul style="list-style-type: none"> Battery becomes weak and the engine does not turn over quick enough. 	<ul style="list-style-type: none"> Clean battery cables & terminals. Charge the battery. In cold weather, always remove the battery from the engine, charge and store it indoors. Install it on the tractor only when the tractor is going to be used.
		<ul style="list-style-type: none"> Preheat (glow plug) system trouble. 	<ul style="list-style-type: none"> Check to see if the slow blow fuse of the preheat (glow plug) blows. Check to see if the preheat (glow plug) functions in cold weather.
Insufficient engine power.		<ul style="list-style-type: none"> Insufficient or dirty fuel. The air cleaner is clogged. 	<ul style="list-style-type: none"> Check the fuel system. Clean or replace the element.
Engine stops suddenly.		<ul style="list-style-type: none"> Insufficient fuel. 	<ul style="list-style-type: none"> Refuel. Bleed the fuel system if necessary.
Exhaust fumes are colored.	Black	<ul style="list-style-type: none"> Fuel quality is poor. Too much oil. The air cleaner is clogged. 	<ul style="list-style-type: none"> Change the fuel and fuel filter. Check the proper amount of oil. Clean or replace the element.
	Blue white	<ul style="list-style-type: none"> The inside of exhaust muffler is dumped with fuel. Injection nozzle trouble. Fuel quality is poor. 	<ul style="list-style-type: none"> Check to see if the preheat (glow plug) functions in cold weather. Heat the muffler by applying load to the engine. Check the injection nozzle. Change the fuel and fuel filter.
Engine overheats		<ul style="list-style-type: none"> Engine overloaded 	<ul style="list-style-type: none"> Shift to lower gear or reduce load.
		<ul style="list-style-type: none"> Low coolant level 	<ul style="list-style-type: none"> Fill cooling system to the correct level; check radiator and hoses for loose connections or leaks.
		<ul style="list-style-type: none"> Loose or defective fan belt 	<ul style="list-style-type: none"> Adjust or replace fan belt.
		<ul style="list-style-type: none"> Dirty radiator core or grille screens 	<ul style="list-style-type: none"> Remove all trash.
		<ul style="list-style-type: none"> Coolant flow route corroded 	<ul style="list-style-type: none"> Flush cooling system.

If you have any questions, contact your local KUBOTA Dealer.

OPTIONS

Consult your local KUBOTA Dealer for further details.

- Engine Block Heater
For extremely cold weather starting
- Front end weights
For front ballast
- Front bumper
- Rear Wheel Weights
For rear ballast
- Sunshade
- Front grill guard
- Double Acting Remote Hydraulic Control Valve with
Float Position
- Double Acting Remote Hydraulic Control Valve
- Draft Control
- Swinging Drawbar
- Clevis Type Swinging Drawbar
- Clevis for Drawbar
- Work Light
High visibility for night work



KUBOTA TRACTOR CORPORATION

CORPORATE OFFICE: 3401 DEL AMO BOULEVARD, TORRANCE, CA 90503

WESTERN DIVISION: 1175 S. Guild Ave., Lodi, CA 95240 • (209) 334-9910

CENTRAL DIVISION: 14855 F.A.A. Blvd., Fort Worth, TX 76155 • (817) 871-0900

NORTHERN DIVISION: One Kubota Way, Groveport, OH 43125 • (614) 835-1100

SOUTHEAST DIVISION: 1025 Northbrook Parkway, Suwanee, GA 30024 • (770) 995-8855

Copyright (c) 2012 by Kubota Tractor Corporation - All Rights Reserved

This manual may not be copied in whole or in part without the written consent of Kubota Tractor Corporation



REPRINTED IN U.S.A.
May 2012
Code No. TC430-59711

