

# WSM

---

WORKSHOP MANUAL  
**TRACTOR**

**STW34,STW37,STW40**

---

**Kubota**

# TO THE READER

This Workshop Manual tells the servicing personnel about the mechanism, servicing and maintenance of the STW34, STW37 and STW40. It contains 4 parts: **"Information"**, **"General"**, **"Mechanism"** and **"Servicing"**.

## ■ Information

This section primarily contains information below.

- Safety First
- Safety Decal
- Specifications
- Dimensions

## ■ General

This section primarily contains information below.

- Engine Identification
- Model Identification
- General Precautions
- Maintenance Check List
- Check and Maintenance
- Special Tools

## ■ Mechanism

This section contains information on the structure and the function of the unit. Before you continue with the subsequent sections, make sure that you read this section.

Refer to the latest version of Workshop Manual (Code No. 9Y021-01870 / 9Y021-18200) for the diesel engine / tractor mechanism that this workshop manual does not include.

## ■ Servicing

This section primarily contains information below.

- Troubleshooting
- Servicing Specifications
- Tightening Torques
- Checking, Disassembling and Servicing

All illustrations, photographs and specifications contained in this manual are of the newest information available at the time of publication.

KUBOTA reserves the right to change all information at any time without notice.

Since this manual includes many models, information or illustrations and photographs can show more than one model.

## **Record of Revisions**

For pdf, use search function {Search word} to find all the revised locations.

<b>Last digit of the Code No.</b>	<b>Issue month</b>	<b>Main Revised Point and Corrective Measures {Search word}</b>	<b>Reference Page</b>
<b>1</b>	2014.11	Correction of specifications.	I-8, G-8, G-19, 1-S21, 1-S31, 2-S6, 2-S15, 3-S16, 3-S30, 4-S4, 4-S10, 5-S5, 5-S11
		Correction of air conditioner belt tension free play.	G-31, 10-S5, 10-S23
		Correction of hydraulic pump allowable limit.	8-S3, 8-S7, 8-S9

# **I INFORMATION**

# INFORMATION

## CONTENTS

1. SAFETY FIRST .....	I-1
2. SAFETY DECALS .....	I-4
3. SPECIFICATIONS.....	I-8
4. TRAVELLING SPEEDS.....	I-10
5. DIMENSIONS.....	I-11

# 1. SAFETY FIRST

## SAFETY FIRST

- This symbol, the industry's "Safety Alert Symbol", is used throughout this manual and on labels on the machine itself to warn of the possibility of personal injury. Read these instructions carefully.
- It is essential that you read the instructions and safety regulations before you try to repair or use this unit.

### DANGER

- Indicates an imminently hazardous situation which, if not avoided, will result in death or serious injury.

### WARNING

- Indicates a potentially hazardous situation which, if not avoided, could result in death or serious injury.

### CAUTION

- Indicates a potentially hazardous situation which, if not avoided, may result in minor or moderate injury.

### ■ IMPORTANT

- Indicates that equipment or property damage could result if instructions are not followed.

### ■ NOTE

- Gives helpful information.

WSM000001INI0001US1

### BEFORE YOU START SERVICE

- Read all instructions and safety instructions in this manual and on your machine safety decals.
- Clean the work area and machine.
- Park the machine on a stable and level ground, and set the parking brake.
- Lower the implement to the ground.
- Stop the engine, then remove the key.
- Disconnect the battery negative cable.
- Hang a "DO NOT OPERATE" tag in the operator station.

WSM000001INI0010US0

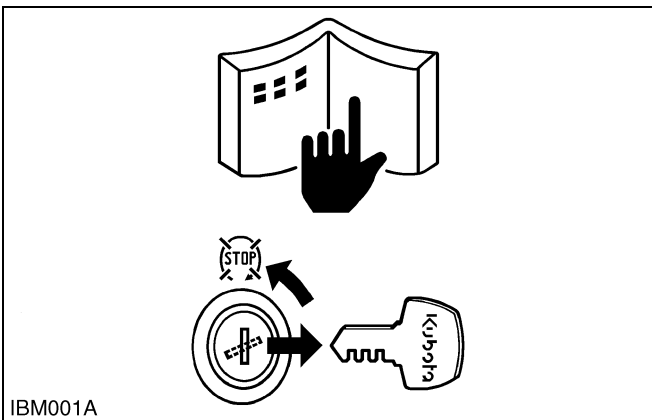

### START SAFELY

- Do not do the procedures below when you start the engine.
  - short across starter terminals
  - bypass the safety start switch
- Do not alter or remove any part of machine safety system.
- Before you start the engine, make sure that all shift levers are in neutral positions or in disengaged positions.
- Do not start the engine when you stay on the ground. Start the engine only from operator's seat.

WSM000001INI0015US0

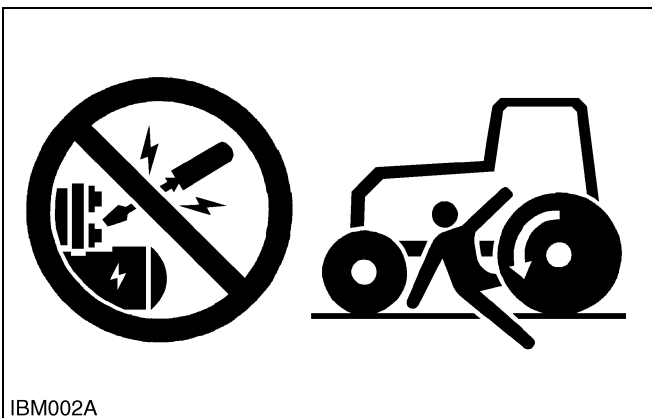

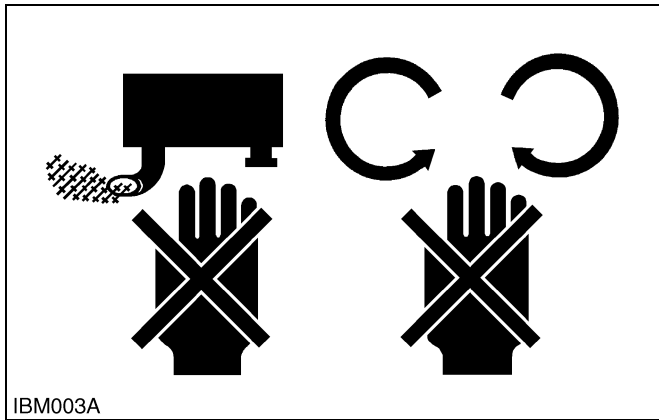

IBM003A

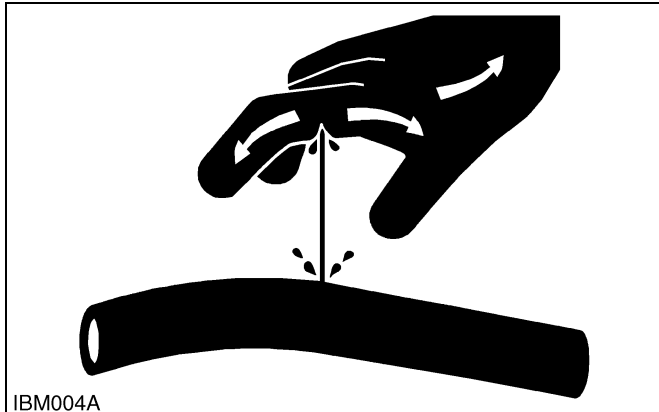

IBM004A

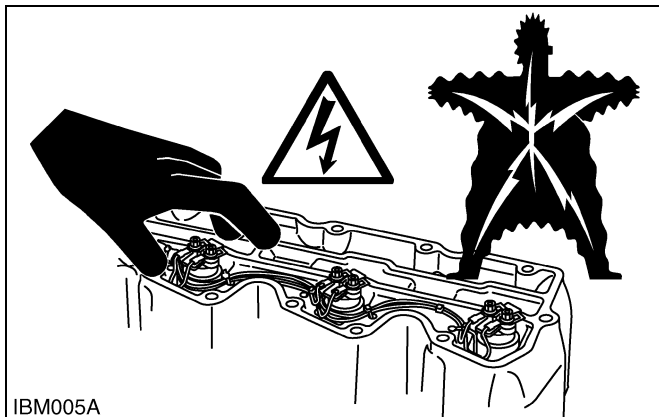

IBM005A

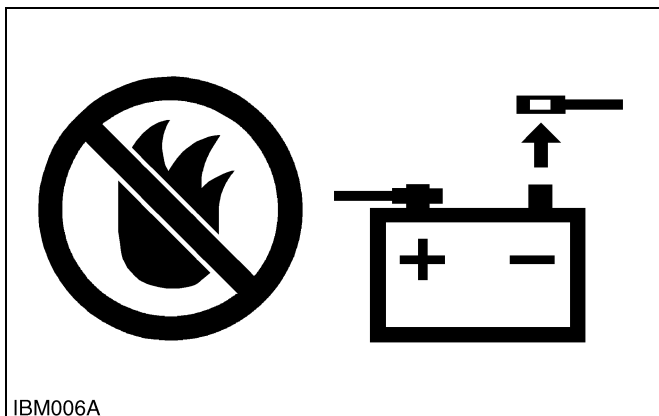

IBM006A

### OPERATE SAFELY

- Do not use the machine after you consume alcohol or medication or when you are tired.
- Put on applicable clothing and safety equipment.
- Use applicable tools only. Do not use alternative tools or parts.
- When 2 or more persons do servicing, make sure that you do it safely.
- Do not operate below the machine that only a jack holds. Always use a safety stand to hold the machine.
- Do not touch the hot parts or parts that turn when the engine operates.
- Do not remove the radiator cap when the engine operates, or immediately after it stops. If not, hot water can spout out from the radiator. Only remove the radiator cap when it is at a sufficiently low temperature to touch with bare hands. Slowly loosen the cap to release the pressure before you remove it fully.
- Released fluid (fuel or hydraulic oil) under pressure can cause damage to the skin and cause serious injury. Release the pressure before you disconnect hydraulic or fuel lines. Tighten all connections before you apply the pressure.
- Do not open a fuel system under high pressure. The fluid under high pressure that stays in fuel lines can cause serious injury. Do not disconnect or repair the fuel lines, sensors, or any other components between the fuel pump and injectors on engines with a common rail fuel system under high pressure.
- Put on an applicable ear protective device (earmuffs or earplugs) to prevent injury against loud noises.
- Be careful about electric shock. The engine generates a high voltage of more than DC100 V in the ECU and is applied to the injector.

WSM000001INI0012US0

### PREVENT A FIRE

- Fuel is very flammable and explosive under some conditions. Do not smoke or let flames or sparks in your work area.
- To prevent sparks from an accidental short circuit, always disconnect the battery negative cable first and connect it last.
- The battery gas can cause an explosion. Keep the sparks and open flame away from the top of battery, especially when you charge the battery.
- Make sure that you do not spill fuel on the engine.

WSM000001INI0005US0

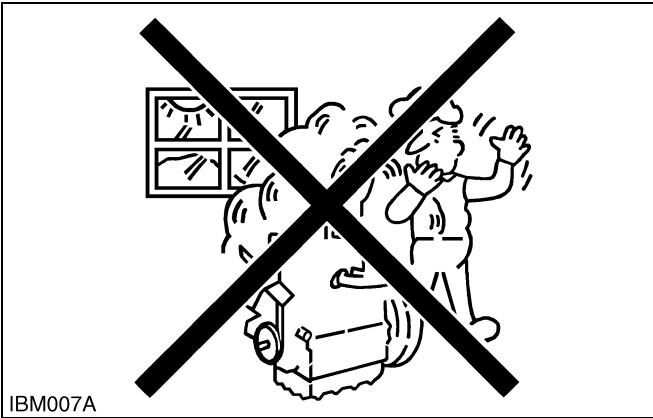

**KEEP A GOOD AIRFLOW IN THE WORK AREA**

- If the engine is in operation, make sure that the area has good airflow. Do not operate the engine in a closed area. The exhaust gas contains poisonous carbon monoxide.

WSM000001INI0006US0

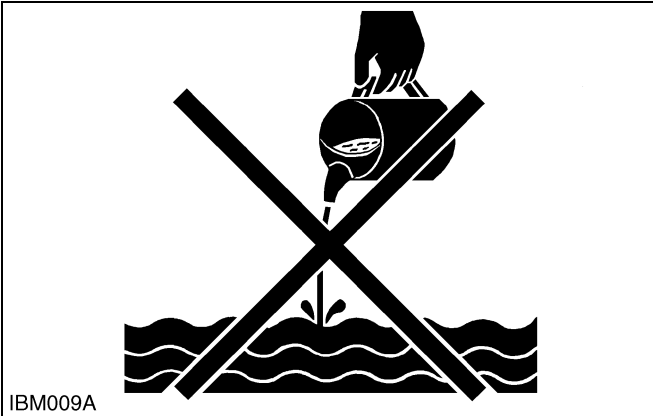

**DISCARD FLUIDS CORRECTLY**

- Do not discard fluids on the ground, down the drain, into a stream, pond, or lake. Obey related environmental protection regulations when you discard oil, fuel, coolant, electrolyte and other dangerous waste.

WSM000001INI0007US0

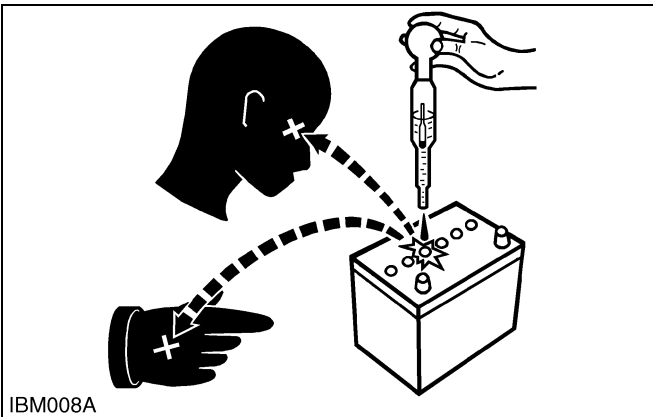

**PREVENT ACID BURNS**

- Keep electrolyte away from your eyes, hands and clothing. Sulfuric acid in battery electrolyte is poisonous and it can burn your skin and clothing and cause blindness. If you spill electrolyte on yourself, clean yourself with water, and get medical aid immediately.

WSM000001INI0008US0

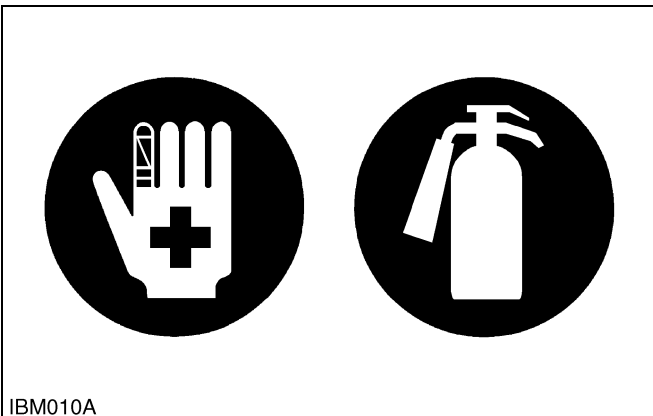

**PREPARE FOR EMERGENCIES**

- Keep a first aid kit and fire extinguisher ready at all times.
- Keep the emergency contact telephone numbers near your telephone at all times.

WSM000001INI0009US0



## 2. SAFETY DECALS

The following safety decals (pictorial safety labels) are installed on the machine. If a decal becomes damaged, illegible or is not on the machine, replace it. The decal part number is listed in the parts list.

WSM000001INI0014US0

(1) Code No. 32751-4958-1



1AGAMAAAP3980

Do not open or remove safety shields while engine is running.

(2) Code No. TC030-4958-1

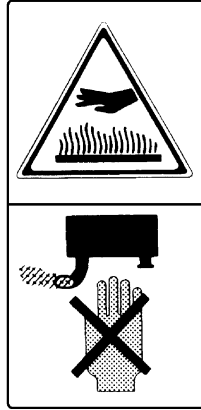

1AGAMAAAP3760

Do not touch hot surfaces.

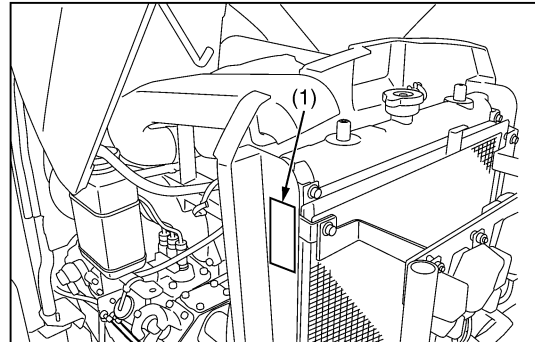
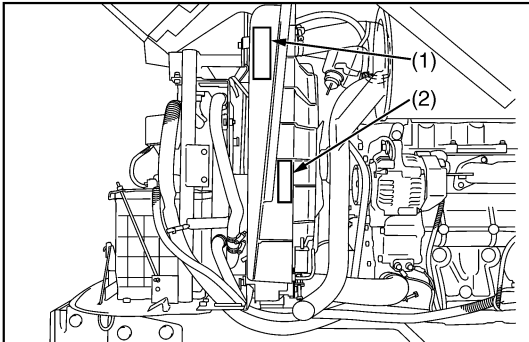

9Y1211109ICI001US

9Y1211109INI0001US0

(1) Code No. TD020-3012-3

 <p>FLAMMABLES</p>	 <p>SHIELD EYES</p>	 <p>KEEP OUT OF THE REACH OF CHILDREN</p>	 <p>CAUTION OF SULFURIC ACID</p>	 <p>READ INSTRUCTION MANUAL CAREFULLY</p>	 <p>EXPLOSIVE</p>
<p>• DUE TO HYDROGEN GAS GENERATED FROM BATTERY HANDLING WITHOUT CARE CAN CAUSE FIRE AND EXPLOSION</p> <p>• THIS 12V BATTERY IS ONLY FOR STARTING ENGINE. DO NOT APPLY THIS PRODUCT FOR OTHER USES.</p> <p>• CHARGE THIS BATTERY ONLY AT WELL VENTILATED PLACES, AND AVOID SHORTS OR SPARKS.</p> <p>• REFER TO THE INSTRUCTION MANUAL OF VEHICLE OR BATTERY BEFORE USING BOOSTER CABLE.</p> <p>• SULFURIC ACID MAY CAUSE BLINDNESS OR SEVERE BURN IN CASE EYES, SKIN, CLOTHES OR ANY ARTICLES ARE STAINED WITH ACID. FLUSH OBJECTS IMMEDIATELY WITH WATER. IF ACID BEING SWALLOWED, DRINK PLENTY OF WATER PROMPTLY. IN CASE OF ACCIDENTAL CONTACT, CONSULT A DOCTOR IMMEDIATELY.</p> <p>• BATTERY FILLED WITH ACID (DO NOT TILT OR SPILL) • FLAMMABLE: DO NOT CHARGE NEAR FIRE OR SPARKS</p> <p>• DO NOT CHARGE RAPIDLY • DO NOT DISASSEMBLE THE BATTERY (SEALED TYPE)</p>					
<p><b>DANGER EXPLOSIVE GASES</b> Cigarettes, flames or sparks could cause battery to explode. Always shield eyes and face from battery. Do not charge or use booster cables or adjust post connections without proper instruction and training.</p> <p><b>POISON CAUSES SEVERE BURNS</b> Contains sulfuric acid. Avoid contact with skin, eyes or clothing. In event of accident flush with water and call a physician immediately.</p> <p><b>KEEP OUT OF REACH OF CHILDREN</b></p>					
<p><b>PROPOSITION 65 WARNING</b> BATTERY POSTS, TERMINALS, AND RELATED ACCESSORIES CONTAIN LEAD AND LEAD COMPOUNDS, CHEMICALS KNOWN TO THE STATE OF CALIFORNIA TO CAUSE CANCER AND REPRODUCTIVE HARM. WASH HANDS AFTER HANDLING.</p>					
<p><b>75D26R</b> <b>12V</b></p>		<p><b>490CCA (SAE)</b> <b>65Ah(20HR)</b></p>		<p><b>460CCA (EN)</b> <b>RC 123(MIN)</b></p>	
<p>S.O.C INDICATOR</p>		<p>OK <input type="radio"/> CHARGE BATTERY <input checked="" type="radio"/> REPLACE BATTERY <input type="radio"/></p>		<p>RECYCLE</p> <p>DK 95492</p>	
<p>FITTING DATE</p>		<p>① ② ③ ④ ⑤ ⑥ ⑦ ⑧ ⑨ YEAR</p> <p>① ② ③ ④ ⑤ ⑥ ⑦ ⑧ ⑨ ⑩ ⑪ ⑫ MONTH</p>			

TO AVOID INJURY FROM BATTERY GASES AND ACIDES



1BDAIAEAP0200

- Keep away cigarettes, flames or sparks.
- Always shield eyes and face from battery
- Keep out of reach of children
- Poison causes severe burns
- Contains sulfuric acid.
- Read and understand operator's manual
- Danger explosive gases

(2) Code No. 3A481-9853-1

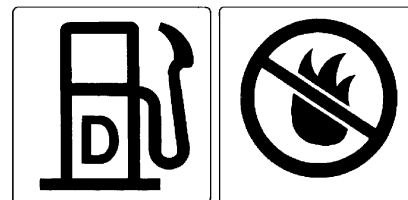

1AGAIAZAP118A

Diesel fuel only.

No fire.

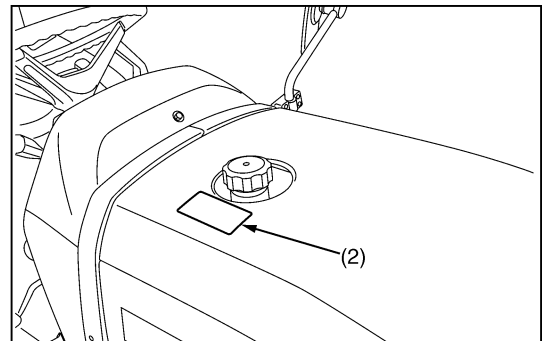
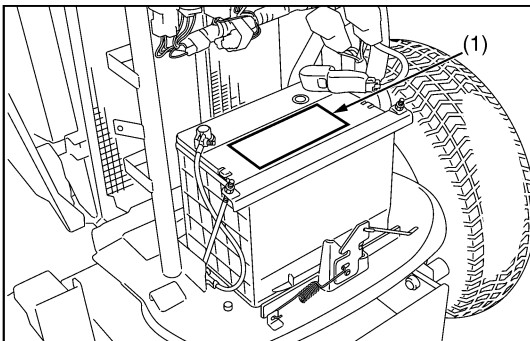

9Y1211109ICI002US

9Y1211109INI0002US0

(1) Code No. K3512-4718-1

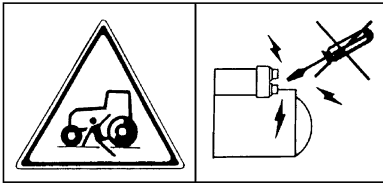

1BDABANAP083B

Start engine from operator's seat only.

(2) Code No. TD169-9848-1 [ROPS Model]

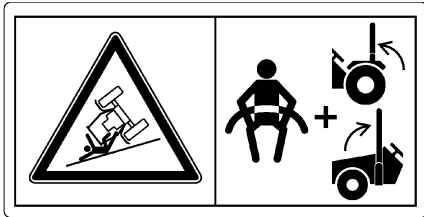

Always look ROPS in upright position unless it has to be folded down to allow operation underneath trees or bushes. When ROPS is locked in upright position seat belt should be used.

(2) Code No. TD179-4902-1 [CAB Model]



1AGAWAEP086A

Seat belt should be used.

(3) Code No. TD179-3491-1

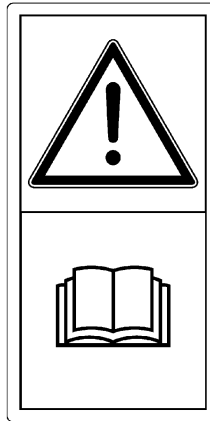

1AGAWAEP088A

Carefully read operator's manual before handling the machine. Observe instructions and safety rules when operating.

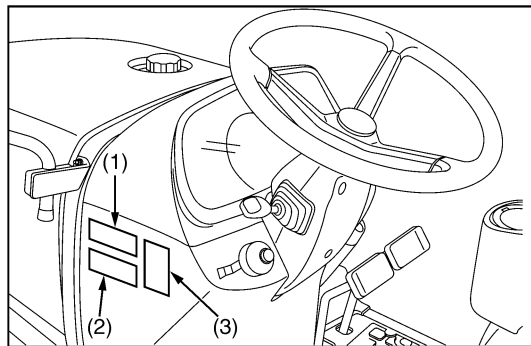

(1) Code No. 6C482-4711-1

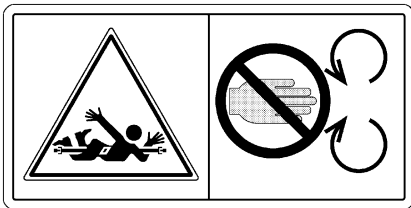

1AGAEEGAP089A

- Stay clear of the PTO shaft.
- Keep PTO shield in place at all times.
- Do not operate the PTO at speeds faster than the speed recommended by the implement manufacturer.
- For trailing PTO-driven implements, set drawbar at towing position.  
(see operator's manual)

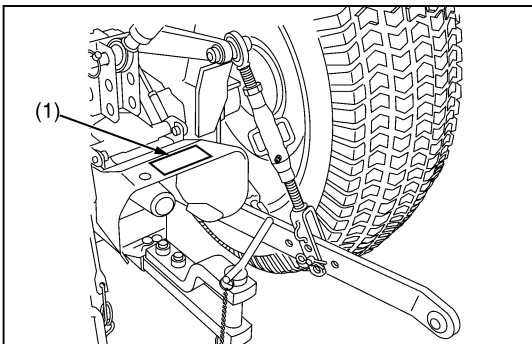

9Y1211109ICI004US

9Y1211109INI0004US0

### **CARE OF PICTORIAL SAFETY LABELS**

1. Keep pictorial safety labels clean and free from obstructing material.
2. Clean pictorial safety labels with soap and water, dry with a soft cloth.
3. Replace damaged or missing pictorial safety labels with new labels.
4. If a component with pictorial safety label(s) affixed is replaced with new part, make sure new label(s) is (are) attached in the same location(s) as the replace component.
5. Mount new pictorial safety labels by applying on a clean dry surface and pressing any bubbles to outside edge.

9Y1211109INI0005US0

### 3. SPECIFICATIONS

Model		STW34	STW37	STW40
Engine power ECE-R24 [97/68/EC]		23.6 kW (32.1 PS) [24.5 kW (33.3 PS)]	25.9 kW (35.2 PS) [26.9 kW (36.6 PS)]	27.3 kW (37.1 PS) [28.3 kW (38.5 PS)]
Engine power SAE gross*1		24.9 kW (33.9 PS)	27.3 kW (37.1 PS)	28.7 kW (39.0 PS)
PTO power *1		16.6 kW (22.6 PS)	19.0 kW (25.9 PS)	20.4 kW (27.8 PS)
Engine	Model	D1703	D1803	D1803
	Type	ETVCS, water-cooled 4-cycle diesel		
	Number of cylinders	3		
	Bore and stroke	87 × 92.4 mm (3.45 × 3.64 in.)	87 × 102.4 mm (3.43 × 4.031 in.)	87 × 102.4 mm (3.43 × 4.031 in.)
	Total displacement	1.647 cm <sup>3</sup> (100.5 cu.in.)	1.826 cm <sup>3</sup> (111.4 cu.in.)	1.826 cm <sup>3</sup> (111.4 cu.in.)
	Rated revolution	2700 min <sup>-1</sup> (rpm)		
	Maximum torque	102.8 N·m (10.5 kgf·m, 75.8 lbf·ft)	113.9 N·m (11.6 kgf·m, 84.0 lbf·ft)	121.8 N·m (12.2 kgf·m, 89.8 lbf·ft)
	Battery	12 V, RC: 123 min, CCA: 490A		
Capacities	Fuel tank	29.5 L (7.79 U.S.gals, 6.49 Imp.gals)		
	Coolant (with recovery tank)	ROPS	6.6 L (7.0 U.S.qts, 5.8 Imp.qts)	
		CAB	7.1 L (7.5 U.S.qts, 6.2 Imp.qts)	
	Engine crankcase (with filter)	5.7 L (6.0 U.S.qts, 5.0 Imp.qts)	6.7 L (7.1 U.S.qts, 5.9 Imp.qts)	
	Transmission case	24 L (6.3 U.S.gals, 5.3 Imp.gals)		
Tires	Front	Farm: 6.00-12 / Turf: 24 × 8.50-14		
	Rear	Farm: 9.5-22 / Turf: 13.6-16		
Dimensions	Overall length (with 3P)	2940 mm (115.7 in.)		
	Overall width (min. tread)	Farm: 1185 mm (46.65 in.) / Turf: 1335 mm (52.56 in.)		
	Overall height	ROPS	Farm: 2350 mm (92.52 in.) / Turf: 2340 mm (92.13 in.)	
		CAB	Farm: 2165 mm (85.24 in.) / Turf: 2155 mm (84.84 in.)	
	Wheel base	1610 mm (63.39 in.)		
Min. ground clearance (Mid PTO case)	Farm: 235 mm (9.25 in.) / Turf: 225 mm (8.86 in.)			
Tread	Front	1020 mm (40.16 in.)		
	Rear	Farm: 950 mm (37.4 in.), 1070 mm (42.134 in.) / Turf: 990 mm (39.0 in.), 1055 mm (41.54 in.)		
Weight	ROPS	Farm: 1105 kg (2436 lbs) / Turf: 1130 kg (2491 lbs)		
	CAB	Farm: 1250 kg (2756 lbs) / Turf: 1275 kg (2811 lbs)		
Min. turning radius	with brake	2.2 m (87 in.)		
	without brake	2.5 m (98 in.)		
Traveling system	Clutch	Single dry disk		
	Steering	Hydrostatic Power Steering		
	Transmission	Main-hydrostatic transmission; range gear shift, 3 forward and 3 reverse		
	Braking system	Wet disk type		
	Trailer brake	applicable		
	Trailer brake coupler	applicable		
	Differential	Bevel gear		
Hydraulic unit	Hydraulic control system	Position control system		
	Pump capacity	30 L/min		
	3-point hitch	SAE Category 1		
	Max. lift force	at lift point	11280 N (1150 kgf, 2535 lbf)	
		24 in. (600 mm) behind lift point	8730 N (890 kgf, 1960 lbf)	
Remote control valve coupler	JISB-2351-1			
PTO	Rear-PTO	SAE 1-3/8, 6 splines		
	PTO / Engine speed	540 / 2670, 800 / 2717		
	Mid-PTO	USA No.5 (KUBOTA 10-tooth) involute spline		
	PTO / Engine speed	2500 min <sup>-1</sup> (rpm) / 2734 min <sup>-1</sup> (rpm)		
The level of protection against hazardous substances *2		Category 1		

Model		STW34	STW37	STW40
Noise at the operator's ear *3	ROPS	83.8 dB (A)	85.8 dB (A)	
	CAB/door closed	84.4 dB (A)	84.4 dB (A)	
	CAB/door opened	84.5 dB (A)	84.5 dB (A)	
Noise of the tractor in motion *4	ROPS	78 dB (A)	79 dB (A)	
	CAB	78 dB (A)	79 dB (A)	
Value of the vibration level *5	GRAMMER MSG83/511	Light driver	1.13 m/s <sup>2</sup>	
		Heavy driver	1.00 m/s <sup>2</sup>	
	GRAMMER MSG93/511	Light driver	1.21 m/s <sup>2</sup>	
		Heavy driver	1.05 m/s <sup>2</sup>	
	COBO SC74/M91	Light driver	1.13 m/s <sup>2</sup>	
		Heavy driver	0.75 m/s <sup>2</sup>	
	COBO SC74/M97	Light driver	1.21 m/s <sup>2</sup>	
		Heavy driver	0.98 m/s <sup>2</sup>	

The company reserve the right to change the specifications without notice.

■ **NOTE**

- \*1 Manufacturer's estimate
- \*2 According to EN 15695-1:2009
- \*3 Measured according to Directive 2009/76/EC ANNEX II
- \*4 Measured according to Directive 2009/63/EC
- \*5 Measured according to Directive 78/764/EEC

9Y1211109INI0006US0

## 4. TRAVELLING SPEEDS

(At rated engine speed)

Model		STW34, STW37, STW40	
Tire Size (Rear)		9.5-22	13.6-16
	Range gear shift lever	km/h (mile/h)	km/h (mile/h)
Forward	1 (Low)	0 to 7.9 (0 to 4.9)	0 to 7.8 (0 to 4.8)
	2 (Middle)	0 to 12.2 (0 to 7.58)	0 to 12.0 (0 to 7.45)
	3 (High)	0 to 34.1 (0 to 21.1)	0 to 33.5 (0 to 20.8)
	Max. Speed (at 2700 engine rpm)	34.1 (21.2)	33.5 (20.8)
Reverse	1 (Low)	0 to 6.1 (0 to 3.7)	0 to 6.0 (0 to 3.7)
	2 (Middle)	0 to 9.4 (0 to 5.8)	0 to 9.3 (0 to 5.7)
	3 (High)	0 to 26.2 (0 to 16.2)	0 to 25.8 (0 to 16.0)
	Max. Speed (at 2700 engine rpm)	26.2 (16.3)	25.8 (16.0)

The company reserves the right to change the specifications without notice.

9Y1211109INI0007US0

# 5. DIMENSIONS

## ROPS

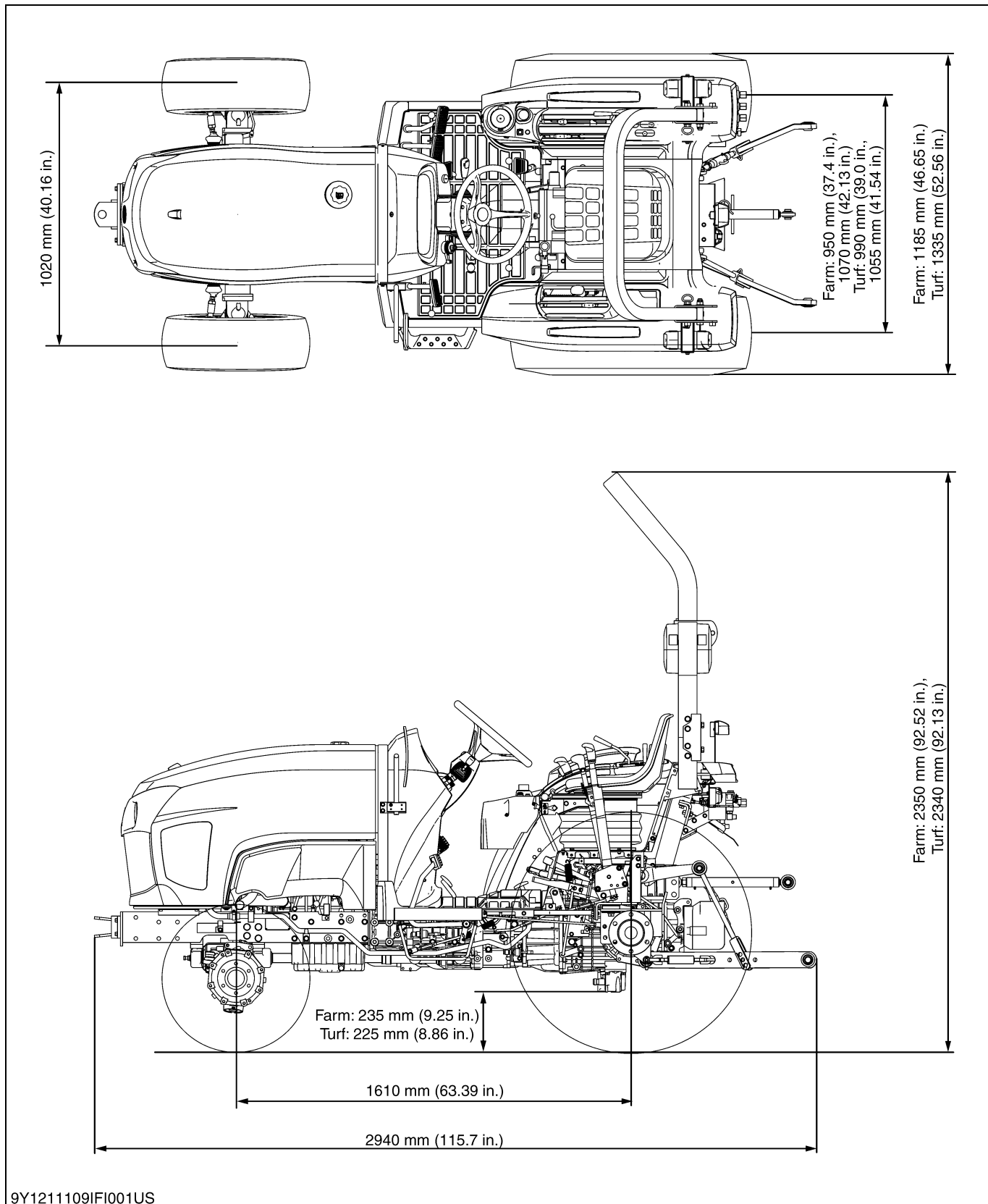



**CABIN**

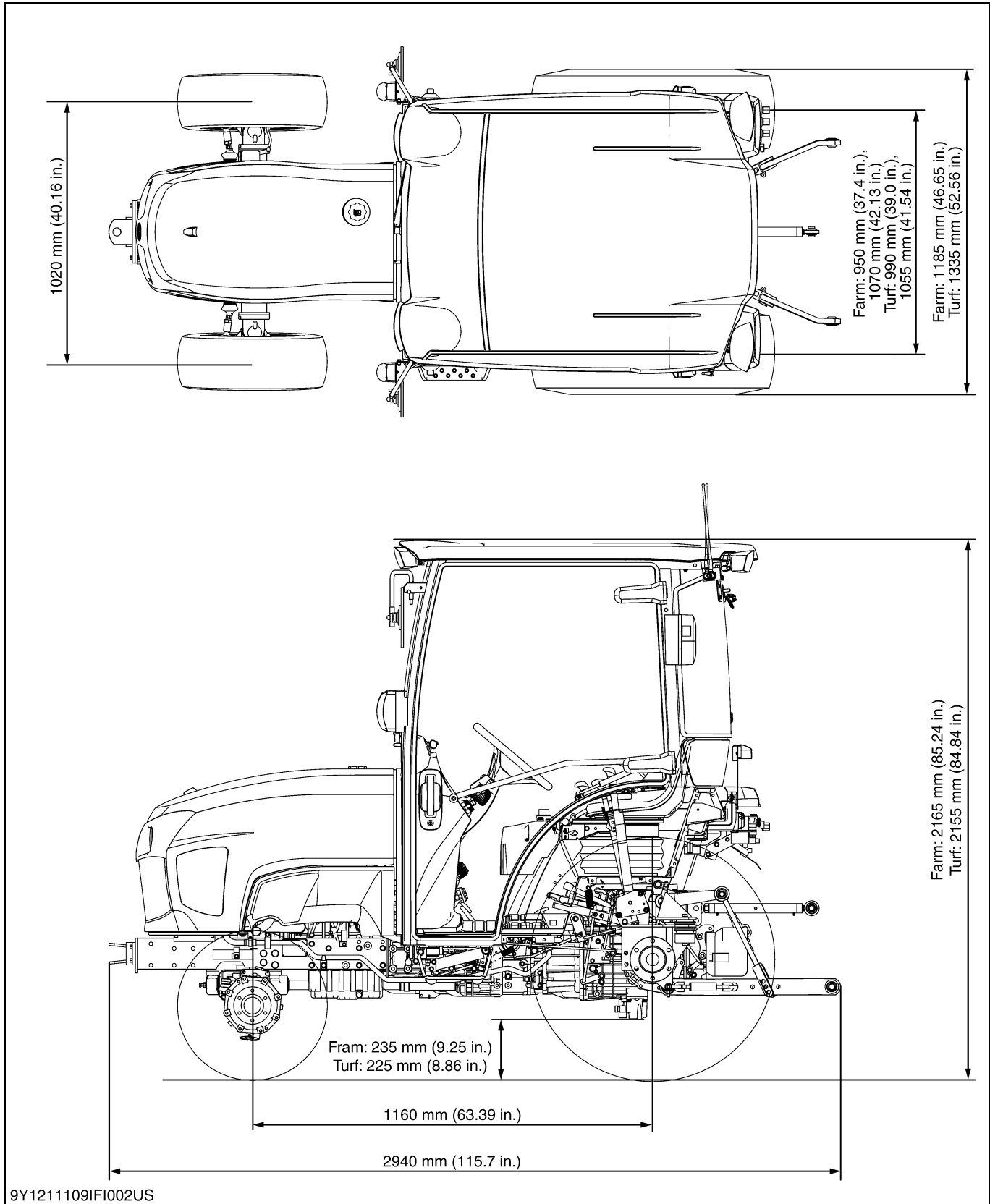

9Y1211109IFI002US

9Y1211109INI0009US0

# **G GENERAL**

# GENERAL

## CONTENTS

1. TRACTOR IDENTIFICATION.....	G-1
2. GENERAL PRECAUTION.....	G-2
3. HANDLING PRECAUTIONS FOR ELECTRICAL PARTS AND WIRING.....	G-3
[1] WIRING.....	G-3
[2] BATTERY.....	G-5
[3] FUSE.....	G-5
[4] CONNECTOR.....	G-5
[5] HANDLING OF CIRCUIT TESTER.....	G-6
[6] COLOR OF WIRING.....	G-7
4. LUBRICANTS, FUEL AND COOLANT.....	G-8
5. TIGHTENING TORQUES.....	G-10
[1] GENERAL USE SCREWS, BOLTS AND NUTS.....	G-10
[2] STUD BOLTS.....	G-10
[3] HYDRAULIC FITTINGS.....	G-11
(1) Hydraulic Hose Fittings.....	G-11
(2) Hydraulic Pipe Cap Nuts.....	G-11
(3) Adaptors, Elbows and Others.....	G-11
[4] METRIC SCREWS, BOLTS AND NUTS.....	G-12
[5] AMERICAN STANDARD SCREWS, BOLTS AND NUTS WITH UNC OR UNF THREADS.....	G-12
[6] PLUGS.....	G-12
6. MAINTENANCE CHECK LIST.....	G-13
7. CHECK AND MAINTENANCE.....	G-15
[1] DAILY CHECK.....	G-15
[2] CHECK POINTS OF INITIAL 50 HOURS.....	G-16
[3] CHECK POINTS OF EVERY 50 HOURS.....	G-20
[4] CHECK POINTS OF EVERY 100 HOURS.....	G-24
[5] CHECK POINTS OF EVERY 200 HOURS.....	G-30
[6] CHECK POINTS OF EVERY 400 HOURS.....	G-33
[7] CHECK POINT OF EVERY 600 HOURS.....	G-33
[8] CHECK POINT OF EVERY 800 HOURS.....	G-33
[9] CHECK POINTS OF EVERY 1 YEAR.....	G-33
[10]CHECK POINTS OF EVERY 2 YEARS.....	G-34
[11]OTHERS.....	G-37
8. SPECIAL TOOLS.....	G-41
[1] SPECIAL TOOLS FOR ENGINE.....	G-41
[2] SPECIAL TOOLS FOR TRACTOR.....	G-47
9. TIRES.....	G-50
[1] TIRE PRESSURE.....	G-50
[2] TREAD.....	G-51
(1) Front Wheels.....	G-52
(2) Rear Wheels.....	G-52
[3] TIRE LIQUID INJECTION.....	G-53

# 1. TRACTOR IDENTIFICATION

When you contact local KUBOTA distributor, always specify engine serial number, the tractor serial number and hour meter reading.

- (1) Tractor Identification Plate
- (2) Tractor Serial Number

- (3) Engine Serial Number

9Y1211109GEG0001US0

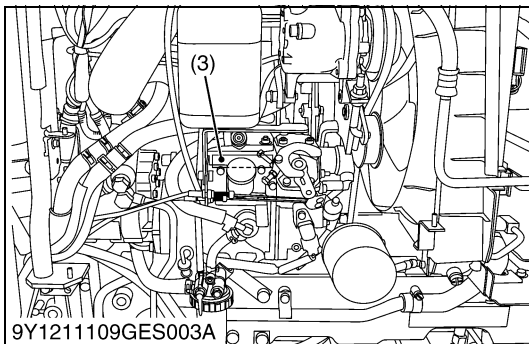
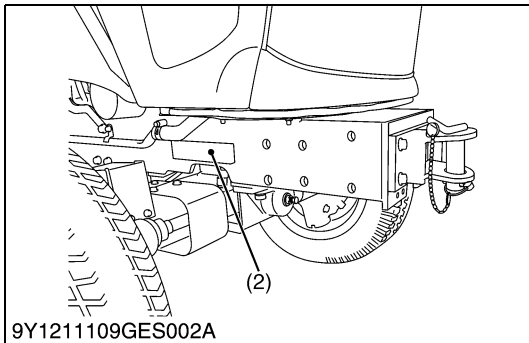
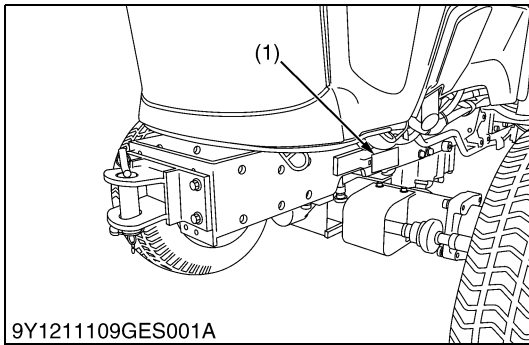

## 2. GENERAL PRECAUTION

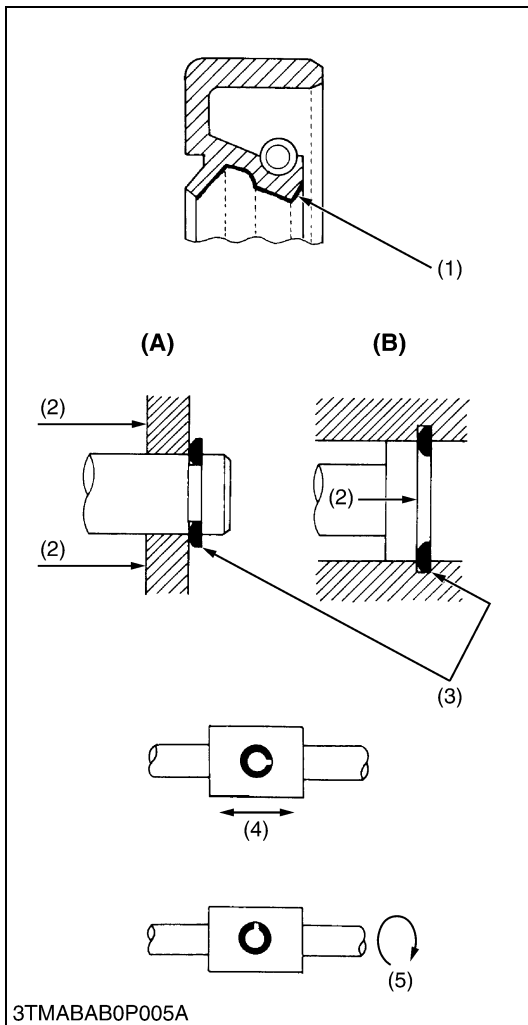

- When you disassemble, carefully put the parts in a clean area to make it easy to find the parts. You must install the screws, bolts and nuts in their initial position to prevent the reassembly errors.
- When it is necessary to use special tools, use KUBOTA special tools. Refer to the drawings when you make special tools that you do not use frequently.
- Before you disassemble or repair machine, make sure that you always disconnect the ground cable from the battery first.
- Remove oil and dirt from parts before you measure.
- Use only KUBOTA genuine parts for replacement to keep the machine performance and to make sure of safety.
- You must replace the gaskets and O-rings when you assemble again. Apply grease (1) to new O-rings or oil seals before you assemble.
- When you assemble the external or internal snap rings, make sure that the sharp edge (3) faces against the direction from which force (2) is applied.
- When inserting spring pins, their splits must face the direction from which a force is applied. See the figure left side.
- To prevent damage to the hydraulic system, use only specified fluid or equivalent.
- Clean the parts before you measure them.
- Tighten the fittings to the specified torque. Too much torque can cause damage to the hydraulic units or the fittings. Not sufficient torque can cause oil leakage.
- When you use a new hose or pipe, tighten the nuts to the specified torque. Then loosen (approx. by 45 °) and let them be stable before you tighten to the specified torque (This is not applied to the parts with seal tape).
- When you remove the two ends of a pipe, remove the lower end first.
- Use two pliers in removal and installation. One to hold the stable side, and the other to turn the side you remove to prevent twists.
- Make sure that the sleeves of flared connectors and tapers of hoses are free of dust and scratches.
- After you tighten the fittings, clean the joint and apply the maximum operation pressure 2 to 3 times to check oil leakage.

- (1) Grease  
 (2) Force  
 (3) Sharp Edge  
 (4) Axial Force  
 (5) Rotating Movement

- (A) External Circlip  
 (B) Internal Circlip

WSM000001GEG0106US0

# 3. HANDLING PRECAUTIONS FOR ELECTRICAL PARTS AND WIRING

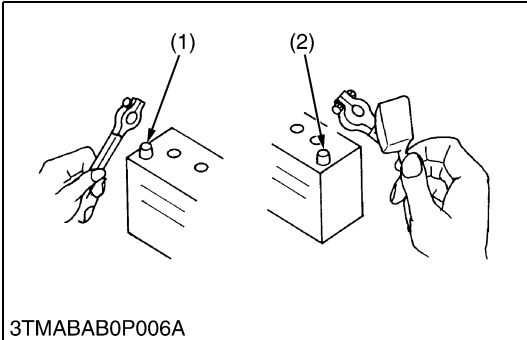

3TMABAB0P006A

To ensure safety and prevent damage to the machine and surrounding equipment, obey the following precautions in handling electrical parts and wiring.

**■ IMPORTANT**

- Check electrical wiring for damage and loosened connection every year. To this end, educate the customer to do his or her own check and at the same time recommend the dealer to perform periodic check for a fee.
- Do not try to modify or remodel any electrical parts and wiring.
- When removing the battery cables, disconnect the negative cable first. When installing the battery cables, connect the positive cable first.

- (1) Negative Terminal (2) Positive Terminal

WSM000001GEG0062US0

## [1] WIRING

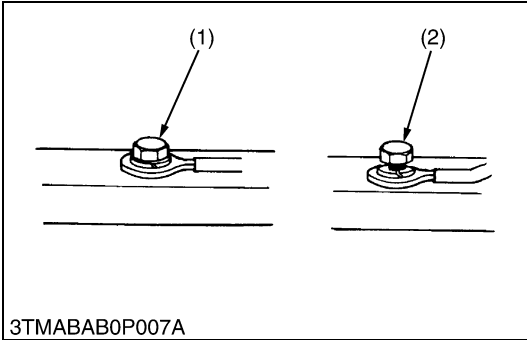

3TMABAB0P007A

- Securely tighten wiring terminals.

- (1) Correct (Securely Tighten) (2) Incorrect (Loosening Leads to Faulty Contact)

WSM000001GEG0063US0

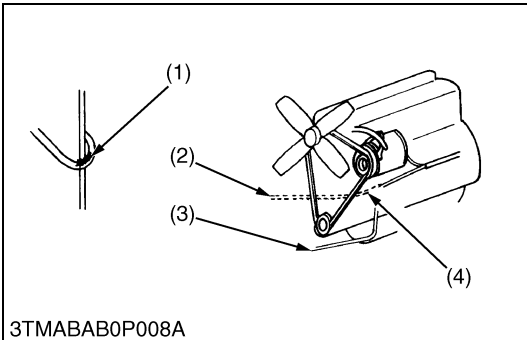

3TMABAB0P008A

- Do not let wiring contact dangerous part.

- (1) Dangerous Part (Sharp Edge) (2) Wiring (Incorrect) (3) Wiring (Correct) (4) Dangerous Part

WSM000001GEG0064US0

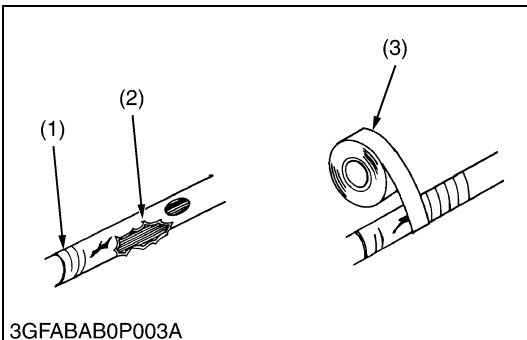

3GFABAB0P003A

- Repair or change torn or aged wiring immediately.

- (1) Aged (2) Torn (3) Insulating Vinyl Tape

WSM000001GEG0065US0

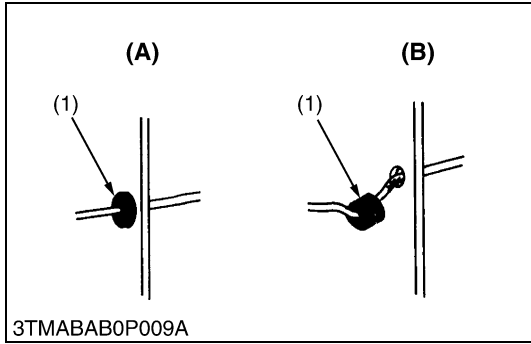

• Securely insert grommet.

(1) Grommet

(A) Correct  
(B) Incorrect

WSM000001GEG0066US0

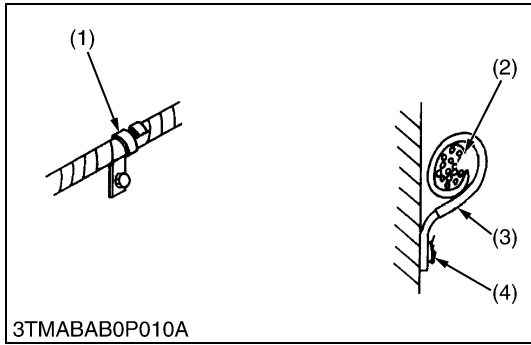

• Securely clamp, being careful not to damage wiring.

(1) Clamp  
(Wind Clamp Spirally)  
(2) Wire Harness

(3) Clamp  
(4) Welding Dent

WSM000001GEG0067US0

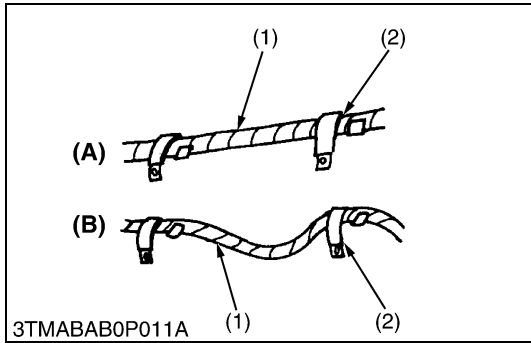

• Clamp wiring so that there is no twist, unnecessary sag, or excessive tension, except for movable part, where sag be required.

(1) Wiring  
(2) Clamp

(A) Correct  
(B) Incorrect

WSM000001GEG0068US0

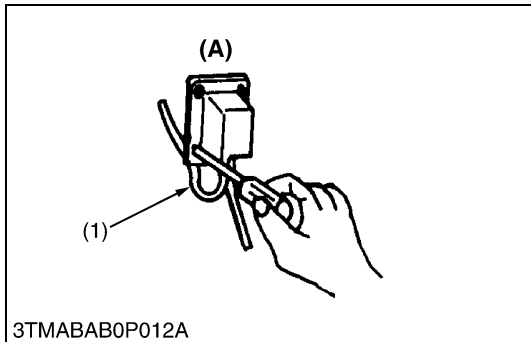

• In installing a part, be careful not to get wiring caught by it.

(1) Wiring

(A) Incorrect

WSM000001GEG0069US0

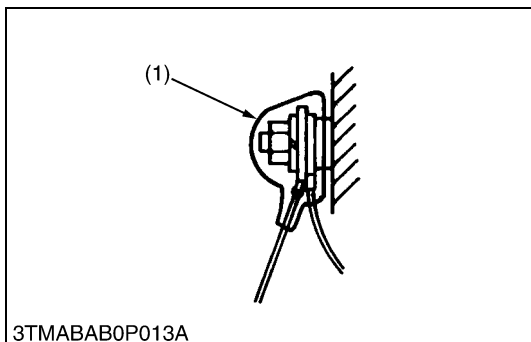

• After installing wiring, check protection of terminals and clamped condition of wiring.

(1) Cover  
(Securely Install Cover)

WSM000001GEG0070US0

## [2] BATTERY

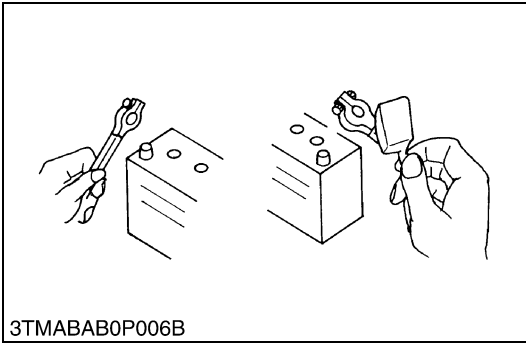

- Be careful not to confuse positive and negative terminal posts.
- When you remove battery cables, disconnect negative cable first. When you install battery cables, check for polarity and connect positive cable first.
- Do not install any battery with capacity other than is specified (Ah).
- After you connect cables to battery terminal posts, apply high temperature grease to them and securely install terminal covers on them.
- Do not allow dirt and dust to collect on battery.

### **⚠ DANGER**

To avoid serious injury or death:

- Be careful not to let battery liquid spill on your skin and clothes. If contaminated, wash it off with water immediately.
- Before you recharge the battery, remove it from the machine.
- Before you recharge, remove cell caps.
- Recharge in a well-ventilated place where there is no open flame nearby, as hydrogen gas and oxygen are formed.

WSM000001GEG0071US0

## [3] FUSE

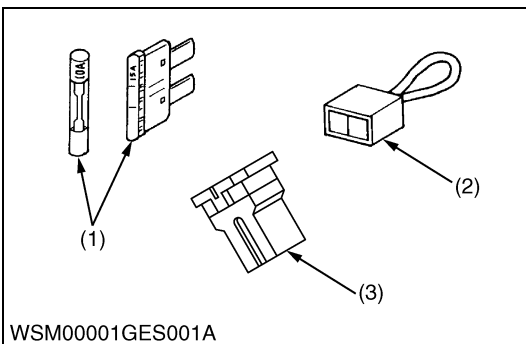

- Use fuses with specified capacity. Neither too large nor small capacity fuse is acceptable.
- Never use steel nor copper wire in place of fuse.
- Do not install working light, radio set, etc. on machine which is not provided with reserve power supply.
- Do not install accessories if fuse capacity of reserve power supply is exceeded.

- (1) Fuse  
(2) Fusible Link

- (3) Slow Blow Fuse

WSM000001GEG0072US0

## [4] CONNECTOR

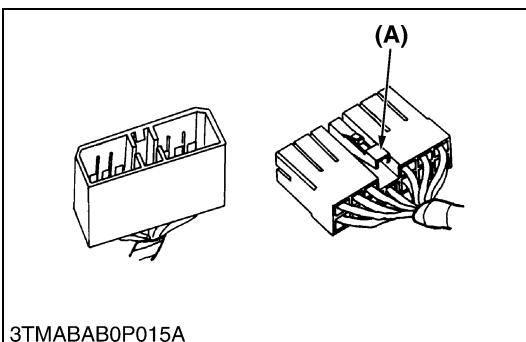

- For connector with lock, push lock to separate.

- (A) Push

WSM000001GEG0073US0

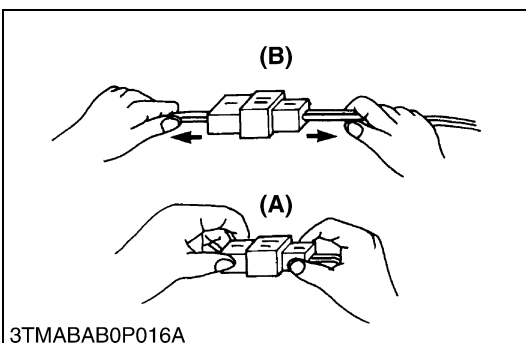

- In separating connectors, do not pull wire harnesses.
- Hold connector bodies to separate.

- (A) Correct

- (B) Incorrect

WSM000001GEG0074US0



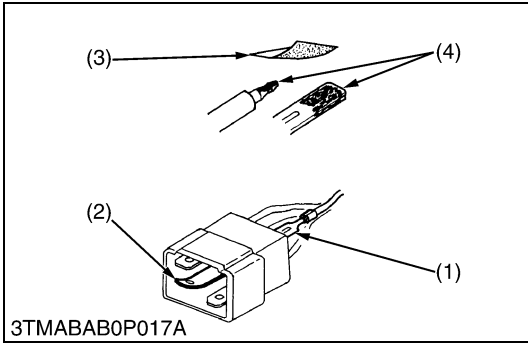

- Use sandpaper to remove rust from terminals.
- Repair deformed terminal. Make sure that there is no terminal being exposed or displaced.

- (1) Exposed Terminal (3) Sandpaper  
 (2) Deformed Terminal (4) Rust

WSM000001GEG0075US0

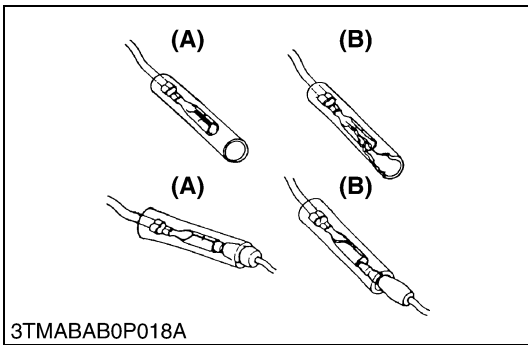

- Make sure that there is no female connector being too open.

- (A) Correct (B) Incorrect

WSM000001GEG0076US0

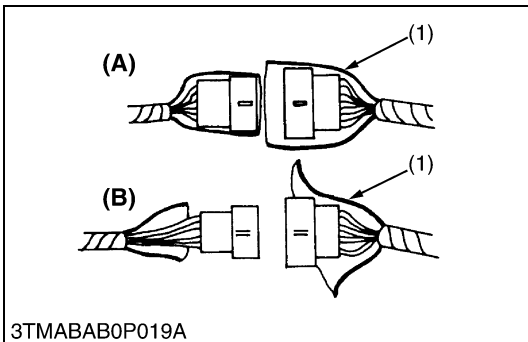

- Make sure that plastic cover is large enough to cover whole connector.

- (1) Cover (A) Correct (B) Incorrect

WSM000001GEG0077US0

## [5] HANDLING OF CIRCUIT TESTER

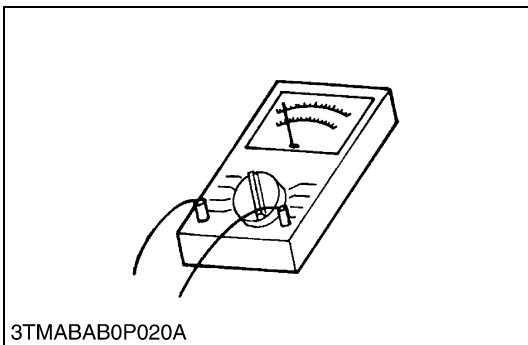

- Use tester correctly following manual provided with tester.
- Check for polarity and range.

WSM000001GEG0078US0

## [6] COLOR OF WIRING

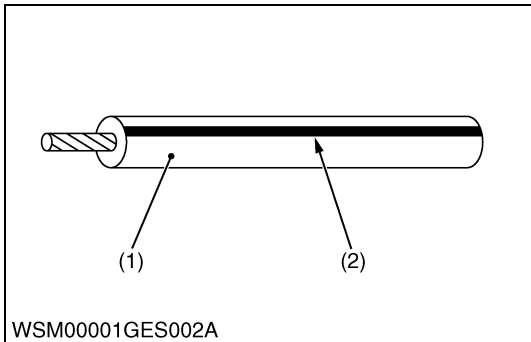

- Colors of wire are specified to the color codes.
- This symbol of "/" shows color with stripe(s).

**(An example)**

Red stripe on white color: W/R

Color of wiring	Color code
Black	B
Brown	Br
Green	G
Gray	Gy or Gr
Blue	L
Light Green	Lg
Orange	Or
Pink	P
Purple	Pu or V
Red	R
Sky Blue	Sb
White	W
Yellow	Y

(1) Wire Color

(2) Stripe

WSM000001GEG0079US0

# 4. LUBRICANTS, FUEL AND COOLANT

No.	Place		Capacity			Lubricants, fuel and coolant
			STW34	STW37	STW40	
1	Fuel		29.5 L 7.79 U.S.gals 6.49 Imp.gals			<ul style="list-style-type: none"> <li>No. 2-D diesel fuel</li> <li>No. 1-D diesel fuel if temperature is below -10 °C (14 °F)</li> </ul>
2	Coolant (with recovery tank)	ROPS	6.6 L 7.0 U.S.qts 5.8 Imp.qts			Fresh clean soft water with anti-freeze
		CABIN	7.1 L 7.5 U.S.qts 6.2 Imp.qts			
3	Engine crankcase (with filter)		5.7 L 6.0 U.S.qts 5.0 Imp.qts	6.7 L 7.1 U.S.qts 5.9 Imp.qts	<b>Engine oil</b> Refer to next page <ul style="list-style-type: none"> <li>Above 25 °C (77 °F): SAE30, SAE10W-30 or 15W-40</li> <li>-10 to 25 °C (14 to 77 °F): SAE20, SAE10W-30 or 15W-40</li> <li>Below -10 °C (14 °F): SAE10W-30</li> </ul>	
4	Transmission case		24 L 6.3 U.S.gals 5.3 Imp.gals			KUBOTA UDT or SUPER UDT fluid*
5	Front axle case oil [4WD]		4.5 L 4.8 U.S.qts 4.0 Imp.qts			KUBOTA UDT or SUPER UDT fluid* or SAE 80-90 gear oil

Greasing				
No.	Place	No. of greasing point	Capacity	Type of grease
6	Greasing	1	Until grease overflows.	Multipurpose Grease NLGI-2 OR NLGI-1 (GC-LB)
	Brake pedal shaft	1		
	Clutch pedal shaft	2		
	Top link	1		
	Lift rod	2		
	Battery terminal	1		
	Cruise control lever	1	moderate amount	Engine oil
Throttle cable	Oiling			

■ **NOTE**

- \*KUBOTA UDT or SUPER UDT fluid---KUBOTA original transmission hydraulic fluid.

9Y1211109GEG0002US0

■ **NOTE**

**Engine Oil**

- Oil used in the engine should have an American Petroleum Institute (API) service classification and Proper SAE Engine Oil according to the ambient temperatures as shown above:
- With the emission control now in effect, the CF-4 and CG-4 lubricating oils have been developed for use of a low sulfur fuel on on-road vehicle engines. When an off-road vehicle engine runs on a high-sulfur fuel, it is advisable to employ the "CF or better" lubricating oil with a high Total Base Number (TBN of 10 minimum).
- Refer to the following table for the suitable API classification engine oil according to the engine type (with internal EGR, external EGR or non-EGR) and the fuel (low-sulfur or high-sulfur fuel).

Fuel used	Engine oil classification (API classification)	
	Oil class of engines except external EGR	Oil class of engines with external EGR
High Sulfur Fuel [≥ 0.05 % (500 ppm)]	<b>CF</b> (If the "CF-4, CG-4, CH-4 or CI-4" lubricating oil is used with a high-sulfur fuel, change the lubricating oil at shorter intervals. (approximately half))	—
Low Sulfur Fuel [< 0.05 % (500 ppm)] or Ultra Low Sulfur Fuel [< 0.0015 % (15 ppm)]	<b>CF, CF-4, CG-4, CH-4 or CI-4</b>	<b>CF or CI-4</b> (Class CF-4, CG-4 and CH-4 engine oils can not be used on EGR type engines)

EGR: Exhaust Gas Re-circulation

- **The CJ-4 engine oil is intended for DPF (Diesel Particulate Filter) type engines, and can not be used on this tractor.**

	except external EGR	with external EGR
Model	STW34, STW37, STW40	—

**Fuel**

- Cetane number of 45 minimum. Cetane number greater than 50 is preferred, especially for temperatures below -20 °C or elevations above 1500 m.
- If diesel fuel with sulfur content greater than 0.5 % (5000 ppm) sulfur content is used, reduce the service interval for engine oil and filter by 50 %.
- NEVER use diesel fuel with sulfur content greater than 0.05 % (500 ppm) for EXTERNAL EGR type engine.
- DO NOT use diesel fuel with sulfur content greater than 1.0 % (10000 ppm).
- Diesel fuels specified to EN 590 or ASTM D975 are recommended.
- No.2-D is a distillate fuel of lower volatility for engines in industrial and heavy mobile service. (SAE J313 JUN87)
- Since this engine adopts EPA Tier 4 and Interim Tier 4 standards, the use of low sulfur fuel or ultra low sulfur fuel is mandatory in EPA regulated area (North America). Therefore, please use No.2-D S500 or S15 diesel fuel as an alternative to No.2-D, or use No.1-D S500 or S15 diesel fuel as an alternative to No.1-D if outside air temperature is below -10 °C.

**Transmission oil**

- The oil used to lubricate the transmission is also used as hydraulic fluid. To insure proper operation of the hydraulic system and to complete lubrication of the transmission, it is important that a multi-grade transmission fluid is used in this system. We recommend the use of KUBOTA UDT or SUPER UDT fluid for optimum protection and performance.  
Do not mix different brands together.



- Indicated capacities of water and oil are manufacturer's estimate.

9Y1211109GEG0003US0

## 5. TIGHTENING TORQUES

### [1] GENERAL USE SCREWS, BOLTS AND NUTS

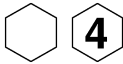
Tighten screws, bolts and nuts whose tightening torques are not specified in this Workshop Manual according to the table below.

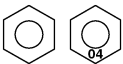
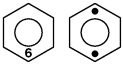
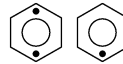
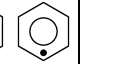
Indication on top of bolt	 No-grade or 4T						 7T						 9T					
Indication on top of nut	 No-grade or 4T												   6T					
Material of opponent part	Ordinariness			Aluminum			Ordinariness			Aluminum			Ordinariness					
Unit	N·m	kgf·m	lbf·ft	N·m	kgf·m	lbf·ft	N·m	kgf·m	lbf·ft	N·m	kgf·m	lbf·ft	N·m	kgf·m	lbf·ft			
M6	7.9	0.80	5.8	7.9	0.80	5.8	9.81	1.00	7.24	7.9	0.80	5.8	12.3	1.25	9.05			
	to 9.3	to 0.95	to 6.8	to 8.8	to 0.90	to 6.5	to 11.2	to 1.15	to 8.31	to 8.8	to 0.90	to 6.5	to 14.2	to 1.45	to 10.4			
M8	18	1.8	13	17	1.7	13	24	2.4	18	18	1.8	13	30	3.0	22			
	to 20	to 2.1	to 15	to 19	to 2.0	to 14	to 27	to 2.8	to 20	to 20	to 2.1	to 15	to 34	to 3.5	to 25			
M10	40	4.0	29	32	3.2	24	48	4.9	36	40	4.0	29	61	6.2	45			
	to 45	to 4.6	to 33	to 34	to 3.5	to 25	to 55	to 5.7	to 41	to 44	to 4.5	to 32	to 70	to 7.2	to 52			
M12	63	6.4	47	-	-	-	78	7.9	58	63	6.4	47	103	10.5	76.0			
	to 72	to 7.4	to 53	-	-	-	to 90	to 9.2	to 66	to 72	to 7.4	to 53	to 117	to 12.0	to 86.7			
M14	108	11.0	79.6	-	-	-	124	12.6	91.2	-	-	-	167	17.0	123			
	to 125	to 12.8	to 92.5	-	-	-	to 147	to 15.0	to 108	-	-	-	to 196	to 20.0	to 144			
M16	167	17.0	123	-	-	-	197	20.0	145	-	-	-	260	26.5	192			
	to 191	to 19.5	to 141	-	-	-	to 225	to 23.0	to 166	-	-	-	to 304	to 31.0	to 224			
M18	246	25.0	181	-	-	-	275	28.0	203	-	-	-	344	35.0	254			
	to 284	to 29.0	to 209	-	-	-	to 318	to 32.5	to 235	-	-	-	to 402	to 41.0	to 296			
M20	334	34.0	246	-	-	-	368	37.5	272	-	-	-	491	50.0	362			
	to 392	to 40.0	to 289	-	-	-	to 431	to 44.0	to 318	-	-	-	to 568	to 58.0	to 419			

WSM000001GEG0001US0

### [2] STUD BOLTS

Material of opponent part	Ordinariness			Aluminum		
Unit	N·m	kgf·m	lbf·ft	N·m	kgf·m	lbf·ft
M8	12	1.2	8.7	8.9	0.90	6.5
	to 15	to 1.6	to 11	to 11	to 1.2	to 8.6
M10	25	2.5	18	20	2.0	15
	to 31	to 3.2	to 23	to 25	to 2.6	to 18
M12	30	3.0	22	31	3.2	23
	to 49	to 5.0	to 36			
M14	62	6.3	46	-	-	-
	to 73	to 7.5	to 54			
M16	98.1	10.0	72.4	-	-	-
	to 112	to 11.5	to 83.1			
M18	172	17.5	127	-	-	-
	to 201	to 20.5	to 148			

WSM000001GEG0002US0

### [3] HYDRAULIC FITTINGS

#### (1) Hydraulic Hose Fittings

Hose size	Thread side	Tightening torque		
		N·m	kgf·m	lbf·ft
02	1/8	13.8 to 15.6	1.40 to 1.60	10.2 to 11.5
03	1/4	22.6 to 27.4	2.30 to 2.80	16.7 to 20.2
04				
05	3/8	45.2 to 52.9	4.60 to 5.40	33.3 to 39.0
06				

WSM000001GEG0097US0

#### (2) Hydraulic Pipe Cap Nuts

Pipe size	Tightening torque		
	N·m	kgf·m	lbf·ft
φ4 × t1.0	19.7 to 29.4	2.00 to 3.00	14.5 to 21.6
φ6 × t1.0	24.6 to 34.3	2.50 to 3.50	18.1 to 25.3
φ8 × t1.0	29.5 to 39.2	3.00 to 4.00	21.7 to 28.9
φ10 × t1.0	39.3 to 49.0	4.00 to 5.00	29.0 to 36.1
φ12 × t1.5	49.1 to 68.6	5.00 to 7.00	36.2 to 50.6
φ15 × t1.6	108 to 117	11.0 to 12.0	79.6 to 86.7
φ18 × t1.6	108 to 117	11.0 to 12.0	79.6 to 86.7

WSM000001GEG0098US0

#### (3) Adaptors, Elbows and Others

Item	Thread side	Tightening torque		
		N·m	kgf·m	lbf·ft
Fitting with O-ring	G 1/8	45 to 53	4.5 to 5.5	33 to 39
	G 1/4	74 to 83	7.5 to 8.5	55 to 61
	G 3/8	93.2 to 102	9.50 to 10.5	68.8 to 75.9
	G 1/2	113 to 122	11.5 to 12.5	83.2 to 90.4
Elbow with O-ring	G 1/8	23 to 26	2.3 to 2.7	17 to 19
	G 1/4	36 to 43	3.6 to 4.4	26 to 31
	G 3/8	54 to 63	5.5 to 6.5	40 to 47
	G 1/2	73 to 83	7.4 to 8.5	54 to 61
Adapter	G 1/8	9.8 to 14	1.0 to 1.5	7.3 to 10
	G 1/4	30 to 34	3.0 to 3.5	22 to 25
	G 3/8	49 to 68	5.0 to 7.0	37 to 50
	G 1/2	69 to 88	7.0 to 9.0	51 to 65

WSM000001GEG0099US0

## [4] METRIC SCREWS, BOLTS AND NUTS

Grade	8.8 Property class 8.8			10.9 Property class 10.9			
	Unit	N·m	kgf·m	lbf·ft	N·m	kgf·m	lbf·ft
<b>M8</b>		24 to 27	2.4 to 2.8	18 to 20	30 to 34	3.0 to 3.5	22 to 25
<b>M10</b>		48 to 55	4.9 to 5.7	36 to 41	61 to 70	6.2 to 7.2	45 to 52
<b>M12</b>		78 to 90	7.9 to 9.2	58 to 66	103 to 117	10.5 to 12.0	76.0 to 86.7
<b>M14</b>		124 to 147	12.6 to 15.0	91.2 to 108	167 to 196	17.0 to 20.0	123 to 144
<b>M16</b>		197 to 225	20.0 to 23.0	145 to 166	260 to 304	26.5 to 31.0	192 to 224



WSM000001GEG0003US0

## [5] AMERICAN STANDARD SCREWS, BOLTS AND NUTS WITH UNC OR UNF THREADS

Grade	SAE GR.5			SAE GR.8			
	Unit	N·m	kgf·m	lbf·ft	N·m	kgf·m	lbf·ft
<b>1/4</b>		11.7 to 15.7	1.20 to 1.60	8.63 to 11.5	16.3 to 19.7	1.67 to 2.00	12.0 to 14.6
<b>5/16</b>		23.1 to 27.7	2.36 to 2.82	17.0 to 20.5	33 to 39	3.4 to 3.9	25 to 28
<b>3/8</b>		48 to 56	4.9 to 5.7	36 to 41	61 to 73	6.3 to 7.4	45 to 53
<b>1/2</b>		110 to 130	11.3 to 13.2	81.2 to 95.8	150 to 178	15.3 to 18.1	111 to 131
<b>9/16</b>		150 to 178	15.3 to 18.1	111 to 131	217 to 260	22.2 to 26.5	160 to 191
<b>5/8</b>		204 to 244	20.8 to 24.8	151 to 179	299 to 357	30.5 to 36.4	221 to 263

WSM000001GEG0008US0

## [6] PLUGS

Shape	Size	Material of opponent part					
		Ordinariness			Aluminum		
		N·m	kgf·m	lbf·ft	N·m	kgf·m	lbf·ft
<b>Tapered screw</b> 	<b>R1/8</b>	13 to 21	1.3 to 2.2	9.4 to 15	13 to 19	1.3 to 2.0	9.4 to 14
	<b>R1/4</b>	25 to 44	2.5 to 4.5	18 to 32	25 to 34	2.5 to 3.5	18 to 25
	<b>R3/8</b>	49 to 88	5.0 to 9.0	37 to 65	49 to 58	5.0 to 6.0	37 to 43
	<b>R1/2</b>	58.9 to 107	6.00 to 11.0	43.4 to 79.5	59 to 78	6.0 to 8.0	44 to 57
<b>Straight screw</b> 	<b>G1/4</b>	25 to 34	2.5 to 3.5	18 to 25	–	–	–
	<b>G3/8</b>	62 to 82	6.3 to 8.4	46 to 60	–	–	–
	<b>G1/2</b>	49 to 88	5.0 to 9.0	37 to 65	–	–	–

WSM000001GEG0005US0

# 6. MAINTENANCE CHECK LIST

No.	Item		Service Interval														After since	Refer- ence page	im- porta nt		
			50	100	150	200	250	300	350	400	450	500	550	600	650	700					
1	Greasing	-	☆	☆	☆	☆	☆	☆	☆	☆	☆	☆	☆	☆	☆	☆	☆	every 50 Hr	G-20		
2	Engine start system	Check	☆	☆	☆	☆	☆	☆	☆	☆	☆	☆	☆	☆	☆	☆	☆	every 50 Hr	G-21		
3	Wheel bolt torque	Check	☆	☆	☆	☆	☆	☆	☆	☆	☆	☆	☆	☆	☆	☆	☆	every 50 Hr	G-23		
4	Brake	Adjust		☆		☆		☆		☆		☆		☆		☆	☆	every 100 Hr	G-27		
5	Fan belt	Adjust		☆		☆		☆		☆		☆		☆		☆	☆	every 100 Hr	G-26		
6	Clutch	Adjust	★	☆		☆		☆		☆		☆		☆		☆	☆	every 100 Hr	G-24		
7	Battery condition	Check		☆		☆		☆		☆		☆		☆		☆	☆	every 100 Hr	G-28	*3	
8	Air cleaner element [Single type]	Clean		☆		☆		☆		☆		☆		☆		☆	☆	every 100 Hr	G-24	*1	
		Replace																every 1 year	G-33		
9	Air cleaner element [Double type]	Primary element		☆		☆		☆		☆		☆		☆		☆	☆	every 100 Hr	G-24	*1	
		Secondary element	Replace																every 1 year	G-33	*2
			Replace																	every 1 year	G-33
10	Fuel filter element	Clean		☆		☆		☆		☆		☆		☆		☆	☆	every 100 Hr	G-25		
		Replace									☆							every 400 Hr	G-33		
11	Parking brake	Adjust		☆		☆		☆		☆		☆		☆		☆	☆	every 100 Hr	G-27		
12	Fuel line	Check		☆		☆		☆		☆		☆		☆		☆	☆	every 100 Hr	G-26		
		Replace																every 2 years	G-34		
13	Engine oil	Change	★			☆					☆				☆		every 200 Hr	G-30			
14	Engine oil filter	Replace	★			☆					☆				☆		every 200 Hr	G-30			
15	Transmission oil filter	Replace	★			☆					☆				☆		every 200 Hr	G-30			
16	Toe-in	Adjust				☆					☆				☆		every 200 Hr	G-31			
17	Radiator hose and clamp	Check				☆					☆				☆		every 200 Hr	G-30			
		Replace																every 2 years	G-34		
18	Power steering oil line	Check				☆					☆				☆		every 200 Hr	G-30			
		Replace																every 2 years	G-34		
19	HST oil line	Check				☆					☆				☆		every 200 Hr	G-30			
		Replace																every 2 years	G-34		
20	Hydraulic oil filter	Replace	★								☆						every 400 Hr	G-19			
21	Transmission fluid	Change									☆						every 400 Hr	G-19			
22	Front axle case oil	Change									☆						every 400 Hr	G-33			



No.	Item		Service Interval													After since	Reference page	important			
			50	100	150	200	250	300	350	400	450	500	550	600	650				700		
23	Front axle pivot	Adjust																☆	every 600 Hr	G-33	
24	Engine valve clearance	Adjust																	every 800 Hr	G-33	
25	Cooling system	Flush																	every 2 years	G-35	
26	Coolant	Change																	every 2 years	G-35	
27	Fuel system	Bleed																	Service as required	G-37	
28	Clutch housing water	Drain																G-37			
29	Fuse	Replace																G-38			
30	Light bulb	Replace																G-39			

**(Only the Check Points for Tractors with CAB)**

No.	Item		Daily	Service Interval								After since	Reference page		
				50	100	150	200	250	300	350	400				
1	Clogging of air conditioner condenser screen	Clean	☆												G-16
2	Tension of air conditioner drive belt	Adjust					☆					☆	every 200 Hr	G-31	
3	Clogging of inner air filter	Clean					☆						every 200 Hr	G-32	
4	Clogging of fresh air filter	Clean					☆						every 200 Hr	G-32	
5	Clogging of air conditioner condenser	Check					☆						every 200 Hr	G-32	
6	Air conditioner pipes and hoses	Check											every 1 year	G-33	
		Replace											every 2 years	G-34	
7	CAB isolation cushion	Check											every 1 year	G-34	
8	Washer liquid	Check											service as required	G-40	
9	Amount of refrigerant (gas)	Check											service as required	G-40	

**IMPORTANT**

- The jobs indicated by must be done after the first 50 hours of operation.
- \*1 Air cleaner should be cleaned more often in dusty conditions than in normal conditions.
- \*2 Every year or every 6 times of cleaning.
- \*3 When the battery is used for less than 100 hours per year, check the battery condition by reading the indicator annually.

9Y1211109GEG0004US0

## 7. CHECK AND MAINTENANCE



### CAUTION

- Be sure to check and service the tractor on a flat place with engine shut off, the parking brake on and chock the wheels.

9Y1211109GEG0005US0

### [1] DAILY CHECK

To prevent trouble from occurring, it is important to know the condition of the tractor well. Check it before starting.



### WARNING

To avoid personal injury or death:

- Take the following precautions when checking the tractor.
- Park the machine on firm and level ground.
- Set the parking brake.
- Lower the implement to the ground.
- All residual pressure of the hydraulic system released.
- Stop the engine and remove the key.

9Y1211109GEG0006US0

### Checking

1. Check the tire pressure, and check for wear and damage.
  2. Check for oil and water leaks.
  3. Check the engine oil level.
  4. Check the transmission fluid level.
  5. Check the coolant level.
  6. Check the condition of seat belt and ROPS attaching hardware.
  7. Check and clean the radiator screen and grill.
  8. Check the screws and nuts of tires are tight.
  9. Check the number plate.
  10. Care of danger, warning and caution labels.
  11. Clean around the exhaust manifold and the muffler of the engine.
  12. Check air cleaner evacuator valve  
(When used in a dusty place)
  13. Check brake and clutch pedal
  14. Check indicators, gauges and meter
  15. Check lights
  16. Check seat belt and ROPS
  17. Check movable parts
  18. Check the fuel level.
- While sitting in the operator's seat.
    1. Check the HST pedal, brake pedals and clutch pedal.
    2. Check the parking brake.
    3. Check the steering wheel.
  - Turning the key switch.
    1. Check the performance of the Easy Checker™ lights.
    2. Check head lights, turn signal lights, hazard lights and other light equipment. Clean if necessary.
    3. Check the performance of the meters and gauges.
  - Starting the engine.
    1. Check to see that the lights on the Easy Checker™ go off.
    2. Check the color of the exhaust gas.
    3. Check the brakes for proper operation.

9Y1211109GEG0007US0

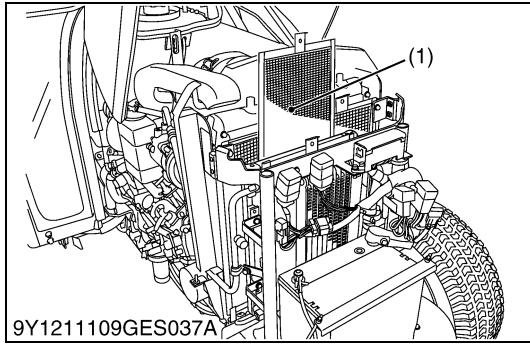

**Cleaning Air Conditioner Condenser Screen [CAB Model]**

**! WARNING**

To avoid personal injury or death:

- Be sure to stop the engine before removing the screen.
- The condenser and receiver become hot while the air conditioner is running. Before checking or cleaning them, wait enough until they cool down.

1. Detach the air conditioner condenser screen and remove all foreign materials.

**■ IMPORTANT**

- Grill and screen must be clean from debris to prevent engine from overheating and to allow good air intake for air cleaner.

(1) Air Conditioner Condenser Screen

9Y1211109GEG0074US0

**[2] CHECK POINTS OF INITIAL 50 HOURS**

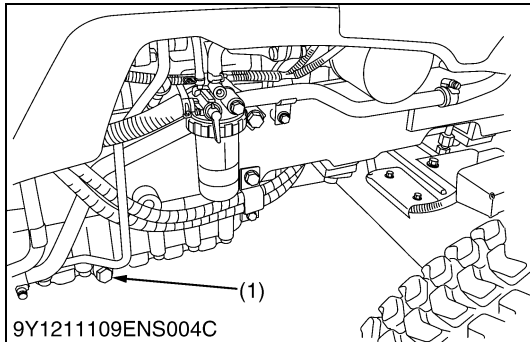

**Changing Engine Oil**

**! WARNING**

To avoid personal injury or death:

- Be sure to stop the engine before changing the oil.
- Allow engine to cool down sufficiently, oil can be hot and can burn.

1. To drain the used oil, remove the drain plug at the bottom of the engine and drain the oil completely into the oil pan. All the used oil can be drained out easily when the engine is still warm.
2. After draining, reinstall the drain plug.
3. Fill with the new oil up to the upper notch on the dipstick. (Refer to "4. LUBRICANTS, FUEL AND COOLANT" on page G-8.)

**■ IMPORTANT**

- When using an oil of different maker or viscosity from the previous one, remove all of the old oil.
- Never mix two different types of oil.
- If oil level is low, do not run engine.

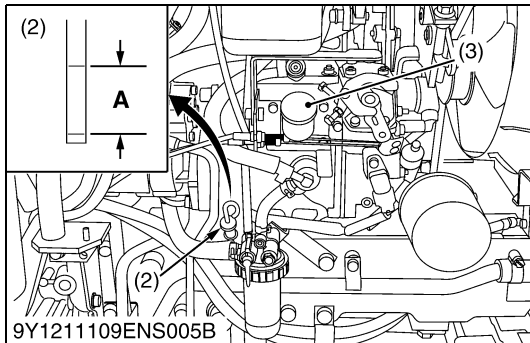

Engine oil	Capacity	STW34	5.7 L 6.0 U.S.qts 5.0 Imp.qts
		STW37, STW40	6.7 L 7.1 U.S.qts 5.9 Imp.qts

- (1) Drain Plug
- (2) Dipstick
- (3) Oil Inlet

**A: Oil level is acceptable within this range.**

9Y1211109GEG0008US0

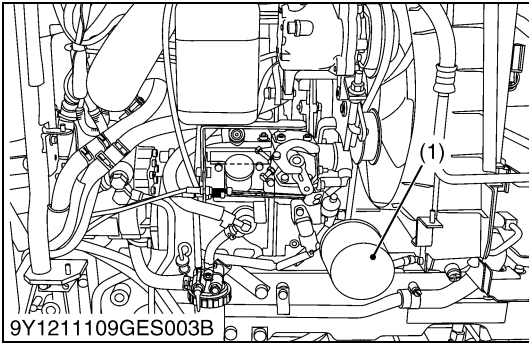

**Replacing Engine Oil Filter Cartridge**

**⚠ WARNING**

To avoid personal injury or death:

- Be sure to stop the engine before changing the oil filter cartridge.
- Allow engine to cool down sufficiently, oil can be hot and can burn.

1. Remove the oil filter.
2. Put a film of clean engine oil on the rubber seal of the new filter.
3. Tighten the filter quickly until it contacts the mounting surface. Tighten filter by hand an additional 1/2 turn only.
4. After the new filter has been replaced, the engine oil normally decreases a little. Make sure that the engine oil does not leak through the seal and be sure to check the oil level on the dipstick. Then, replenish the engine oil up to the prescribed level.

**■ IMPORTANT**

- To prevent serious damage to the engine, use only a KUBOTA genuine filter.

(1) Engine Oil Filter

9Y1211109GEG0009US0

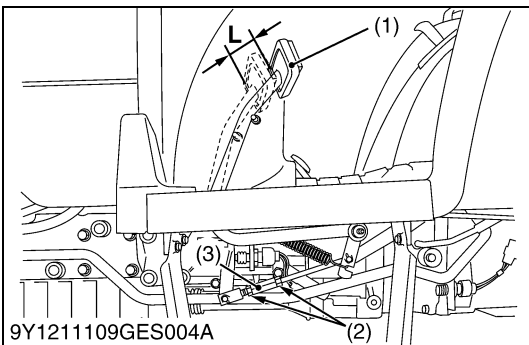

**Checking Clutch Pedal Free Travel**

**⚠ CAUTION**

- When checking, park the tractor on flat ground, apply the parking brake, stop the engine and remove the key.

1. Stop the engine and remove the key.
2. Slightly depress the clutch pedal and measure free travel at the top of pedal stroke.
3. If adjustment is needed, loosen the lock nut and turn the turnbuckle to adjust the rod length within acceptable limits.
4. Retighten the lock nut.

**■ IMPORTANT**

- After adjustment, be sure to check that engine does not start without depressing the clutch pedal but engine start when depressing the clutch pedal.

Clutch pedal free travel "L"	Factory specification	20.0 to 30.0 mm 0.78 to 1.18 in.
------------------------------	-----------------------	-------------------------------------

- (1) Clutch Pedal
- (2) Lock Nut
- (3) Turnbuckle

**L: Free Travel**

9Y1211109GEG0010US0

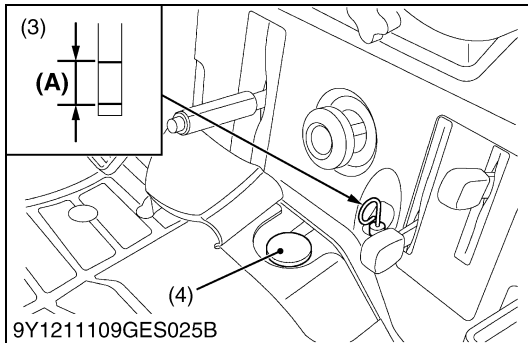
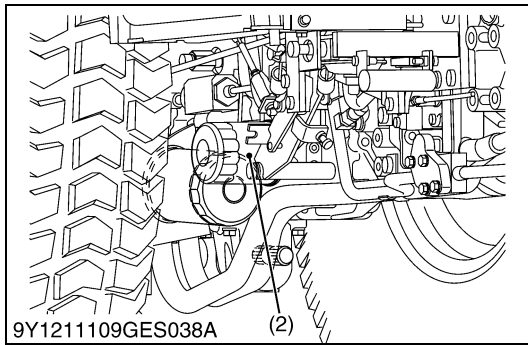
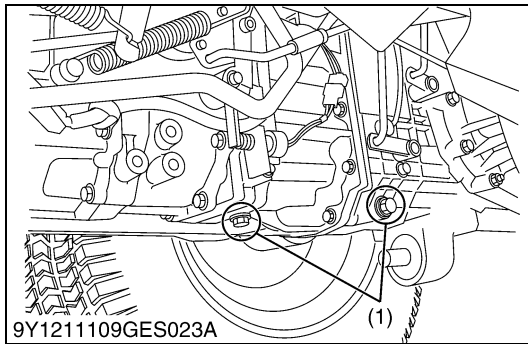

## Replacing Transmission Oil Filter

### **!** WARNING

To avoid personal injury or death:

- Be sure to stop the engine before changing the oil filter cartridge.
- Allow engine to cool down sufficiently, oil can be hot and can burn.

1. Remove the drain plugs at the bottom of the transmission case and drain the oil completely into the oil pan.
2. After draining reinstall the drain plugs.
3. Remove the oil filter.
4. Put a film of clean transmission oil on the rubber seal of the new filter.
5. Quickly tighten the filter until it contacts the mounting surface, then, with a filter wrench, tighten it an additional 1 turn only.
6. After the new filter has been replaced, fill the transmission oil up to the upper notch on the dipstick.
7. After running the engine for a few minutes, stop the engine and check the oil level again, add oil to the prescribed level.
8. Make sure that the transmission fluid doesn't leak past the seal on the filter.

### ■ IMPORTANT

- To prevent serious damage to the hydraulic system, use only a KUBOTA genuine filter.
- Do not operate the tractor immediately after changing the transmission fluid.

Run the engine at medium speed for a few minutes to prevent damage to the transmission.

- (1) Drain Plugs  
(2) Transmission Oil Filter  
(3) Dipstick  
(4) Oil inlet

(A) Oil level is acceptable within this range.

9Y1211109GEG0075US0

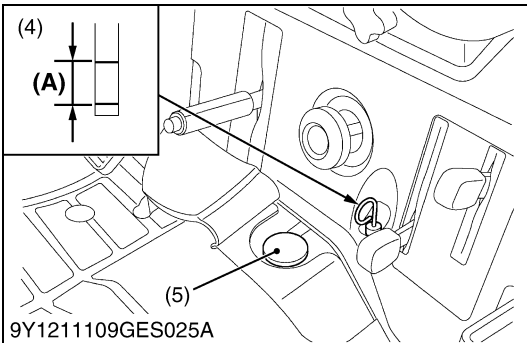
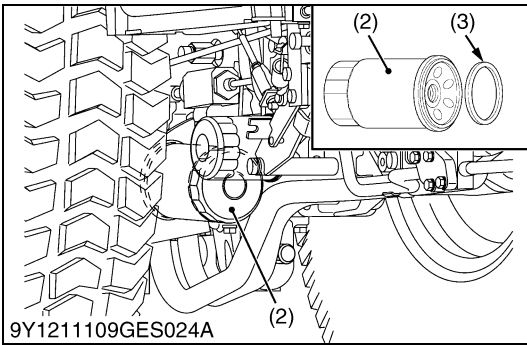
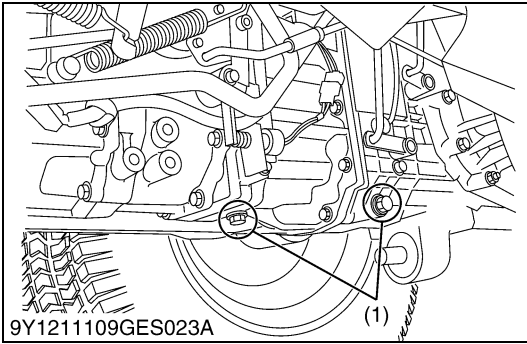

**Changing Transmission Fluid / Replacing Hydraulic Oil Filter**

**■ Cleaning Magnetic Filter**

**⚠ WARNING**

To avoid personal injury or death:

- Be sure to stop the engine before changing the oil filter cartridge.
- Allow engine to cool down sufficiently, oil can be hot and can burn.

1. Remove the drain plugs at the bottom of the transmission case and drain the oil completely into the oil pan.
2. After draining reinstall the drain plugs.
3. Remove the oil filter.
4. Wipe off metal filings from the magnetic filter with a clean rag.
5. Put a film of clean transmission oil on the rubber seal of the new filter.
6. Quickly tighten the filter until it contacts the mounting surface, then tighten it by hand an additional 1/2 turn only.
7. Fill with the new KUBOTA SUPER UDT fluid up to the upper notch on the dipstick.  
(Refer to "4. LUBRICANTS, FUEL AND COOLANT" on page G-8.)
8. After running the engine for a few minutes, stop the engine and check the oil level again, add oil to the prescribed level.
9. Make sure that the transmission fluid doesn't leak past the seal on the filter.

Transmission oil	Capacity	24 L 6.3 U.S.gals 5.3 Imp.gals
------------------	----------	--------------------------------------

- |   |  |
|---|--|
| <ul style="list-style-type: none"> <li>(1) Drain Plugs</li> <li>(2) Hydraulic Oil Filter</li> <li>(3) Magnetic Filter<br/>(Wipe Off Metal Filings)</li> </ul> | <ul style="list-style-type: none"> <li>(4) Dipstick</li> <li>(5) Oil Inlet</li> <li><b>(A) Oil level is acceptable within this range.</b></li> </ul> |
|---|--|

9Y1211109GEG0030US0

### [3] CHECK POINTS OF EVERY 50 HOURS

#### Greasing

1. Apply a grease to the following position as figures.

- |                                     |   |
|-------------------------------------|---|
| (1) Grease Fitting (Top Link)       | (4) Grease Fitting (Brake Pedal Shaft)  |
| (2) Grease Fitting (Lifting Rod RH) | (5) Grease Fitting (Clutch Pedal Shaft) |
| (3) Battery Terminal                | (6) Cruise Control Lever Guide          |

9Y1211109GEG0011US0

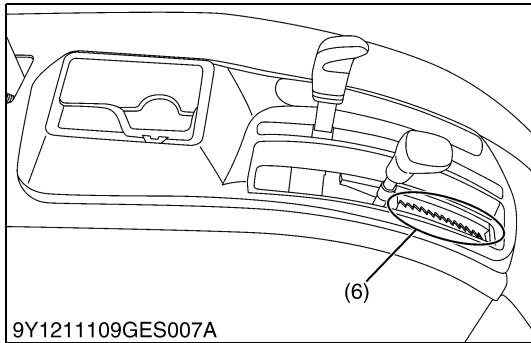
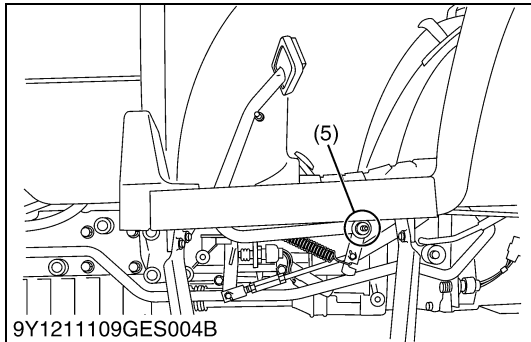
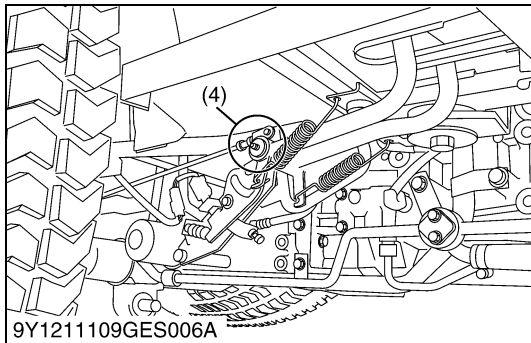
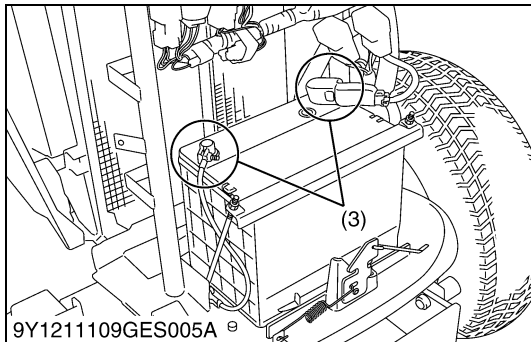
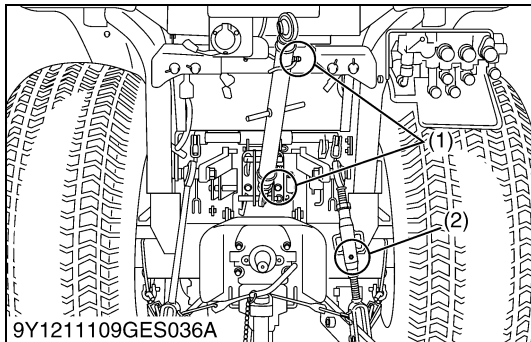

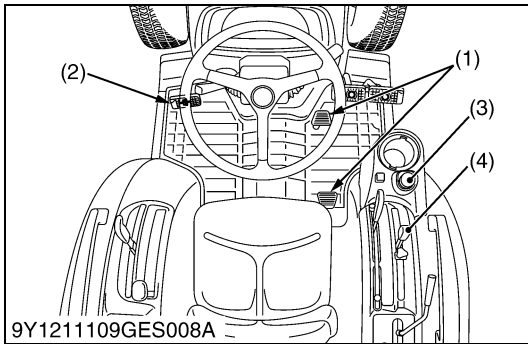

### Checking Engine Start System

#### **⚠ WARNING**

To avoid personal injury or death:

- Do not allow anyone near the tractor while testing.
- If the tractor does not pass the test do not operate the tractor.

#### ■ Preparation before testing

1. Place all control levers in the "NEUTRAL" position.
2. Set the parking brake and stop the engine.

#### ■ Test: Switch for the speed control pedal.

1. Sit on the operator's seat.
2. Depress the speed control pedal to the desired direction.
3. Depress the clutch pedal fully.
4. Disengage the PTO clutch control switch, and disengage the rear and mid-PTO gear shift levers.
5. Turn the key to "START" position.
6. The engine must not crank.

#### ■ Test: Switch for the mid-PTO gear shift lever.

1. Sit on the operator's seat.
2. Disengage the rear PTO gear shift lever, and engage the mid-PTO gear shift lever.
3. Depress the clutch pedal fully.
4. Place the speed control pedal in "NEUTRAL" position.
5. Turn the key to "START" position.
6. The engine must not crank.

#### ■ Test: Switch for the clutch pedal.

1. Sit on the operator's seat.
2. Disengage the PTO clutch control switch, and disengage the rear and mid-PTO gear shift levers.
3. Place the speed control pedal in "NEUTRAL" position.
4. Release the clutch pedal.
5. Turn the key to "START" position.
6. The engine must not crank.

- (1) Speed Control Pedal  
(2) Clutch Pedal

- (3) PTO Clutch Control Switch  
(4) Rear PTO Gear Shift Lever

9Y1211109GEG0012US0



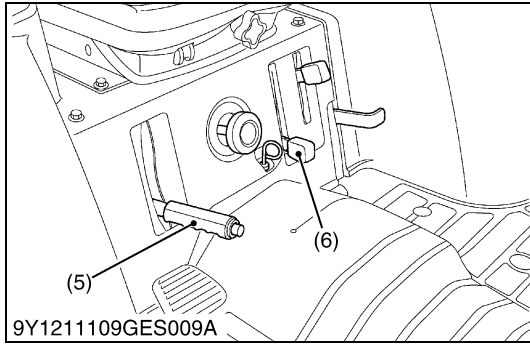
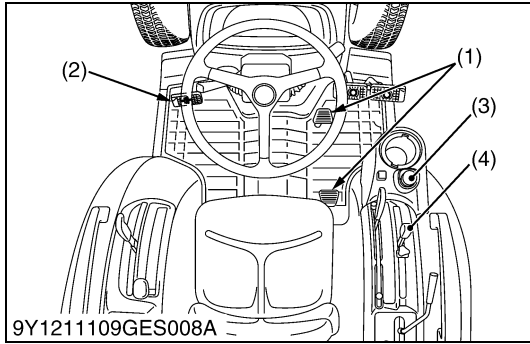

**Checking Operator Presence Control**

**! WARNING**

To avoid personal injury or death:

- Do not allow anyone near the tractor while testing.
- If the tractor does not pass the test, do not operate the tractor.

■ **Test: Switch for the operator's seat.**

1. Sit on the operator's seat.
2. Start the engine.
3. Engage the mid-PTO gear shift lever.
4. Stand up. (Do not get off the machine.)

■ **Test: Switch for the operator's seat.**

1. Sit on the operator's seat.
2. Start the engine.
3. Engage the mid-PTO gear shift lever.
4. Stand up. (Do not get off the machine.)
5. The engine must shut off after approximately 1 second.

■ **Test: Switch for the parking brake lever.**

1. Sit on the operator's seat.
2. Start the engine.
3. Engage the rear PTO gear shift lever, and disengage the mid-PTO gear shift lever.
4. Release the parking brake.
5. Stand up. (Do not get off the machine.)
6. The engine must shut off after approximately 1 second.

■ **Test: Switch for the operator's seat**

1. Sit on the operator's seat.
2. Start engine.
3. Engage the mid-PTO gear shift lever.
4. Stand up. (Do not get off the machine.)
5. The engine must shut off after approximately 1 second.

■ **Test: Switch for the parking brake lever**

1. Sit on the operator's seat.
2. Start engine.
3. Engage the rear PTO gear shift lever, and disengage the mid-PTO gear shift lever.
4. Release the parking brake.
5. Stand up. (Do not get off the machine.)
6. The engine must shut off after approximately 1 second.

- |                               |                               |
|-------------------------------|-------------------------------|
| (1) Speed Control Pedal       | (4) Rear PTO Gear Shift Lever |
| (2) Clutch Pedal              | (5) Parking Brake Lever       |
| (3) PTO Clutch Control Switch | (6) Mid-PTO Gear Shift Lever  |

9Y1211109GEG0013US0

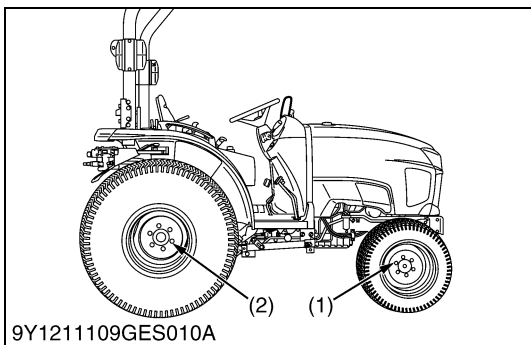

**Checking Wheel Bolt Torque**

**⚠ WARNING**

To avoid personal injury or death:

- Never operate tractor with a loose rim, wheel, or axle.
  - Any time bolts and nuts are loosened, retighten to specified torque.
  - Check all bolts and nuts frequently and keep them tight.
1. Check the wheel mounting screws and nuts regularly especially when new. If there are loosened, tighten as follows.

Tightening torque	Front wheel mounting screw and nut	85 N·m 9.0 kgf·m 65.1 lbf·ft
	Rear wheel mounting screw and nut	215 N·m 22.0 kgf·m 159.1 lbf·ft

- (1) Front Wheel Mounting Screw and Nut      (2) Rear Wheel Mounting Screw and Nut

9Y1211109GEG0014US0

## [4] CHECK POINTS OF EVERY 100 HOURS

### Checking Clutch Pedal Free Travel

- See page G-17.

9Y1211109GEG0015US0

### Cleaning Air Cleaner Element

#### [Single Element]

1. Remove the element.
2. Clean the element:
  - (1) When dry dust adheres to the element, blow compressed air from the inside, turning the element. Pressure of compressed air must be under 205 kPa (2.1 kgf/cm<sup>2</sup>, 30 psi).
  - (2) When carbon or oil adheres to the element, soak the element in detergent for 15 minutes then wash it several times in water, rinse with clean water and dry it naturally. After element is fully dried, inspect inside of the element with a light and check if it is damaged or not. (referring to the instructions on the label attached to the case.)
3. Replace air cleaner element:  
Once yearly or after every sixth cleaning, whichever comes first.

#### ■ NOTE

- Check to see if the evacuator valve is blocked with dust.

#### ■ IMPORTANT

- The air cleaner uses a dry element, never apply oil.
- Do not run the engine with filter element removed.
- Be sure to refit the cover with the arrow mark (on the rear) upright. If the cover is improperly fitted, dust passed by the baffle and directly adheres to the element.

#### ■ Evacuator Valves

Open the evacuator valve once a week under ordinary conditions - or daily when used in a dusty place - to get rid of large particles of dust and dirt.

#### [Double Element Type]

1. Remove the air cleaner cover and primary element.
2. Clean the primary element:
  - (1) When dry dust adheres to the element, blow compressed air from the inside, turning the element. Pressure of compressed air must be under 205 kPa (2.1 kgf/cm<sup>2</sup>, 30 psi).
  - (2) When carbon or oil adheres to the element, soak the element in detergent for 15 minutes then wash it several times in water, rinse with clean water and dry it naturally. After element is fully dried, inspect inside of the element with a light and check if it is damaged or not.
3. Replace air cleaner primary element:  
Once yearly or after every sixth cleaning, whichever comes first.

#### ■ NOTE

- Check to see if the evacuator valve is blocked with dust.

- |                     |                                |
|---------------------|--------------------------------|
| (1) Element         | (5) Secondary (Safety) Element |
| (2) Cover           |                                |
| (3) Evacuator Valve | [A] Single Element Type        |
| (4) Primary Element | [B] Double Element Type        |

(To be continued)

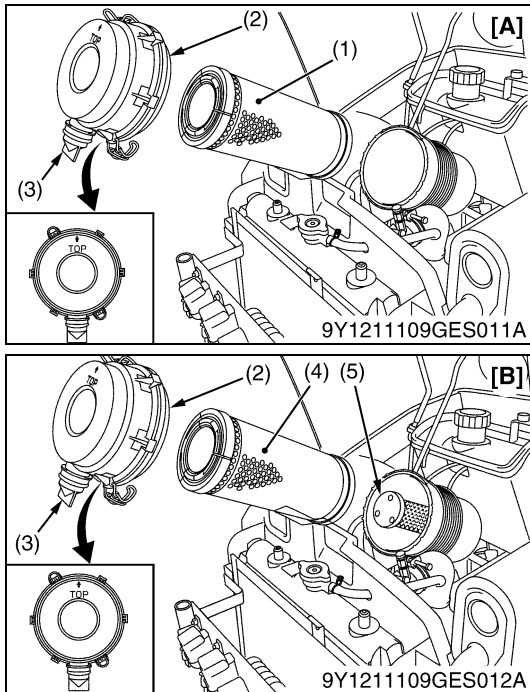

(Continued)

■ **IMPORTANT**

- The air cleaner uses a dry element, never apply oil.
- Do not run the engine with filter element removed.
- Be sure to refit the cover with the arrow mark (on the rear of cover) upright. If the cover is improperly fitted, evacuator valve will not function and dust will adhere to the element.
- Do not touch the secondary element except in cases where replacing is required.

■ **Evacuator Valves**

Open the evacuator valve once a week under ordinary conditions - or daily when used in a dusty place - to get rid of large particles of dust and dirt.

9Y1211109GEG0016US0

**Cleaning Fuel Filter**

This job should not be done in the field, but in a clean place.

1. Close the fuel valve.
2. Unscrew the screw ring and remove the filter bowl, and rinse the inside with kerosene.
3. Take out the element and dip it in the kerosene to rinse.
4. After cleaning, reassemble the fuel filter, keeping out dust and dirt.
5. Bleed the fuel system. (See page G-37.)

■ **IMPORTANT**

- If dust and dirt enters the fuel system the fuel pump and injection nozzles are subject to premature wear. To prevent this, be sure to clean the fuel filter bowl periodically.

- |                      |                |
|----------------------|----------------|
| (1) Fuel Valve       | (5) Screw Ring |
| (2) Fuel Filter Bowl | (6) Spring     |
| (3) O-ring           |                |
| (4) Filter Element   |                |

**A: Close**

9Y1211109GEG0017US0

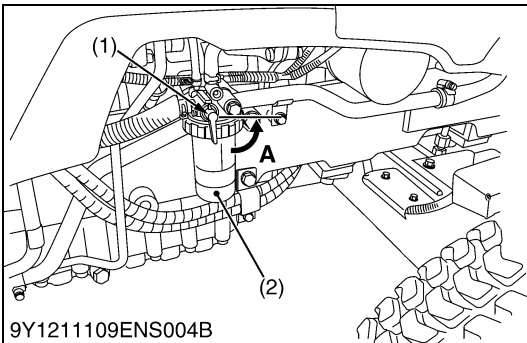

9Y1211109ENS004B

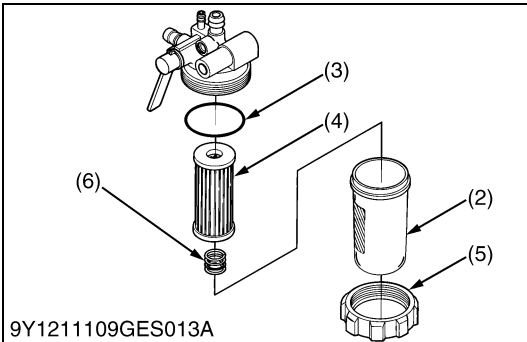

9Y1211109GES013A

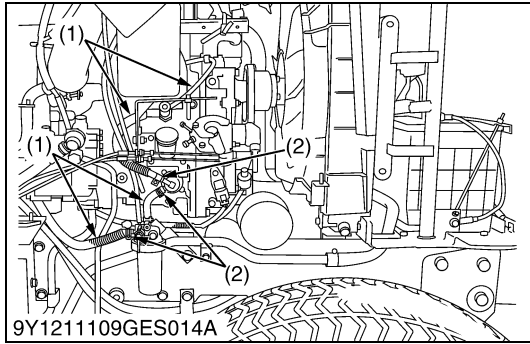

**Checking Fuel Line**

**CAUTION**

- Stop the engine when attempting the check and change prescribed below.
- Remember to check the fuel line periodically. The fuel line is subject to wear and aging, fuel may leak out onto the running engine, causing a fire.

1. Check to see that all line and hose clamps are tight and not damaged.
2. If hoses and clamps are found worn or damaged, replace or repair them at once.
3. The fuel line is made of rubber and ages regardless of period of service. Replace the fuel pipe together with the clamp every two years and securely tighten.
4. However if the fuel pipe and clamp are found damaged or deteriorated earlier than two years, then change or remedy.
5. After the fuel line and clamp have been changed, bleed the fuel system. (See page G-37.)

**IMPORTANT**

- When the fuel line is disconnected for change, close both ends of the fuel line with a piece of clean cloth or paper to prevent dust and dirt from entering. Entrance of dust and dirt causes malfunction of the fuel injection pump. In addition, particular care must be taken not to admit dust and dirt into the fuel pump.

(1) Fuel Hose

(2) Clamp

9Y1211109GEG0018US0

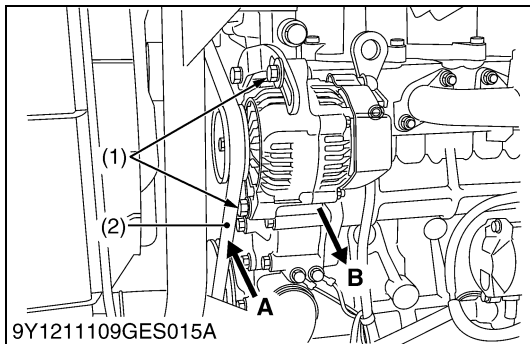

**Checking Fan Belt Tension**

**CAUTION**

- Be sure to stop engine before checking belt tension.

1. Stop the engine and remove the key.
2. Apply moderate thumb pressure to belt between pulleys.
3. If tension is incorrect, loosen the alternator mounting bolts and using a lever placed between the alternator and the engine block, pull the alternator out until the deflection of the belt falls within acceptable limits.
4. Replace fan belt if it is damaged.

Fan Belt tension	Factory specification	A deflection of between 10 to 12 mm (0.40 to 0.47in.) when the belt is pressed in the middle of the span.
------------------	-----------------------	---

(1) Adjusting Screw

(2) Fan Belt

**A: Check the belt tension**

**B: To tighten**

9Y1211109GEG0019US0

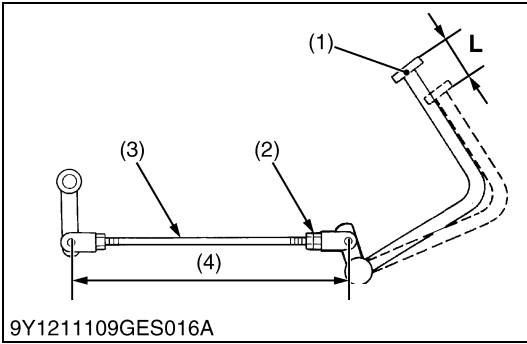

**Adjusting Brake Pedal Free Travel**

**⚠ WARNING**

To avoid personal injury or death:

- Stop the engine and chock the wheels before checking brake pedal.
1. Release the parking brake.
  2. Slightly depress the brake pedals and measure free travel at top of pedal stroke.
  3. If adjustment is needed, loosen the lock nut and turn the brake rod to adjust the rod length within acceptable limits.
  4. Retighten the lock nut.

Brake pedal free travel "L"	Factory specification	20 to 30 mm 0.79 to 1.18 in.
-----------------------------	-----------------------	---------------------------------

- (1) Brake Pedal
- (2) Lock Nut
- (3) Brake Rod
- (4) Length of Brake Rod

**L: Free Travel**

9Y1211109GEG0020US0

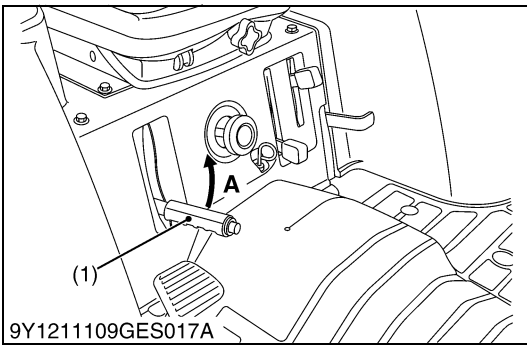

**Adjusting Parking Brake Lever**

**⚠ CAUTION**

- Be sure to stop engine before checking parking brake.
1. Slowly raise the parking brake lever (1) to the ratchet sound made by the parking brake lever.
  2. If the No. of notch is not within the factory specifications, loosen the lock nut (2) and turn the brake rod to adjust within acceptable limits.
  3. Retighten the lock nut (2) securely.

Parking brake lever free travel	2 notches (Ratchet sound 2)
---------------------------------	--------------------------------

**■ IMPORTANT**

- Check the brake pedal free travel after adjusting the parking brake.

**■ NOTE**

- Refer to "BRAKE" section for detailed method.

- (1) Parking Brake Lever
- (2) Lock Nut
- (3) Parking brake rod

**A: Pull**

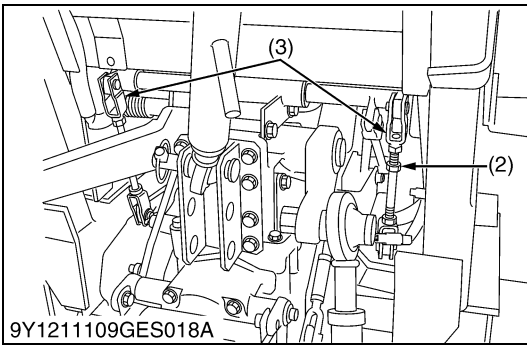

9Y1211109GEG0021US0

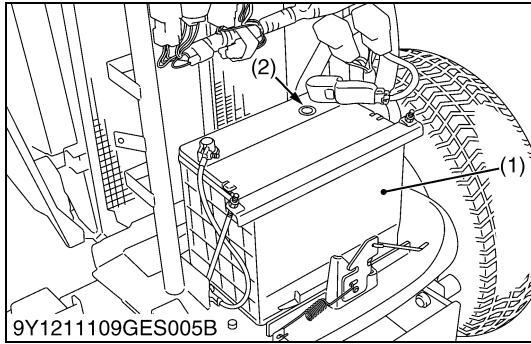

**Checking Battery Condition**

**! DANGER**

To avoid the possibility of battery explosion:  
For the refillable type battery, follow the instructions below.

- Do not use or charge the refillable type battery if the fluid level is below the LOWER (lower limit level) mark. Otherwise, the battery component parts may prematurely deteriorate, which may shorten the battery's service life or cause an explosion. Check the fluid level regularly and add distilled water as required so that the fluid level is between the UPPER and LOWER levels.

**! WARNING**

To avoid personal injury or death:

- Never remove the battery cap while the engine is running.
- Keep electrolyte away from eyes, hands and clothes. If you are spattered with it, wash it away completely with water immediately and get medical attention.
- Keep open sparks and flames away from the battery at all times. Hydrogen gas mixed with oxygen becomes very explosive.
- Wear eye protection and rubber gloves when working around battery.

The factory-installed battery is of non-refillable type. If the indicator turns white, do not charge the battery but replace it with new one.

Mishandling the battery shortens the service life and adds to maintenance costs. The original battery is maintenance free, but needs some servicing.

If the battery is weak, the engine will be difficult to start and the lights will be dim. It is important to check the battery periodically.

State of indicator display	
Green	Specific gravity of electrolyte and quality of electrolyte are both in good condition.
Black	Needs charging battery.
White	Needs changing battery.

(1) Battery

(2) Indicator

9Y1211109GEG0022US0

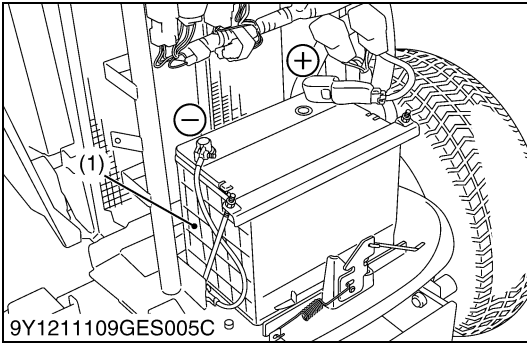

## Battery Charging

### **⚠ WARNING**

To avoid personal injury or death:

- When the battery is being activated, hydrogen and oxygen gases in the battery are extremely explosive. Keep open sparks and flames away from the battery at all times, especially when charging the battery.
  - When charging the battery, ensure the vent caps are securely in place. (if equipped)
  - When disconnecting the cable from the battery, start with the negative terminal first. When connecting the cable to the battery, start with the positive terminal first.
  - Never check battery charge by placing a metal object across the posts. Use a voltmeter or hydrometer.
1. To slow charge the battery, connect the battery positive terminal to the charger positive terminal and the negative to the negative, then recharge in the standard fashion.
  2. A boost charge is only for emergencies. It will partially charge the battery at a high rate and in a short time. When using a boost-charged battery, it is necessary to recharge the battery as early as possible. Failure to do this will shorten the battery's service life.
  3. The battery is charged if the indicator display turns green from black.
  4. When exchanging an old battery for a new one, use battery of equal specification shown in **Table 1**.

**Table 1**

Battery TYPE	volts	Reserve Capacity (min)	CCA (SAE) (A)	Normal Charging Rate (A)
75D26R	12	123	490	6.5

### ■ Direction for Storage

1. When storing the tractor for long periods of time, remove the battery from tractor, adjust the electrolyte to the proper level and store in a dry place out of direct sunlight.
2. The battery self-discharges while it is stored. Recharge it once every three months in hot seasons and once every six months in cold seasons.

(1) Battery

9Y1211109GEG0023US0



## [5] CHECK POINTS OF EVERY 200 HOURS

### Changing Engine Oil

- See page G-16.

9Y1211109GEG0024US0

### Changing Engine Oil Filter

- See page G-17.

9Y1211109GEG0077US0

### Changing Transmission Oil Filter

- See page G-18.

9Y1211109GEG0078US0

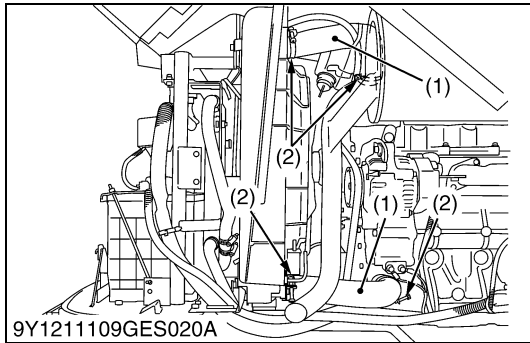

### Checking Radiator Hose and Hose Clamp

Check to see if radiator hoses are properly fixed every 200 hours of operation or six months, whichever comes first.

1. If hose clamps (2) are loose or water leaks, tighten hose clamps (2) securely.
2. Replace hoses (1) and tighten hose clamps (2) securely, if radiator hoses (1) are swollen, hardened or cracked. Replace hoses and hose clamps every 2 years or earlier if checked and found that hoses are swollen, hardened or cracked.

#### ■ **Precaution at Overheating**

Take the following actions in the event the coolant temperature be nearly or more than the boiling point, what is called "Overheating".

1. Stop the machine operation in a safe place and keep the engine unloaded idling.
2. Do not stop the engine suddenly, but stop it after about 5 minutes of unloaded idling.
3. Keep yourself well away from the machine for further 10 minutes or while the steam blown out.
4. Checking that there gets no danger such as burn, get rid of the causes of overheating according to the manual, see "TROUBLESHOOTING" section, and then start again the engine.

(1) Radiator Hose

(2) Clamp

9Y1211109GEG0025US0

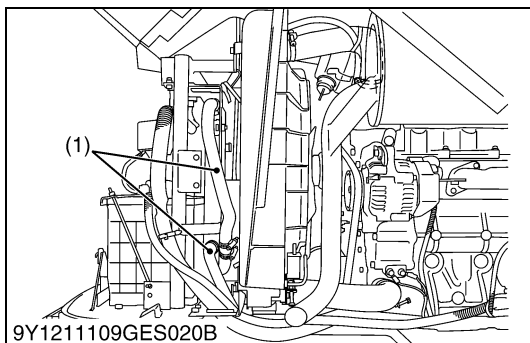

### Checking HST Oil Line and Power Steering Hose

1. Check to see that all lines (1), (2) and hose clamps are tight and not damaged.
2. If hoses and clamps are found worn or damaged, replace or repair them at once.

(1) HST Oil Line

(2) Power Steering Hose

9Y1211109GEG0026US0

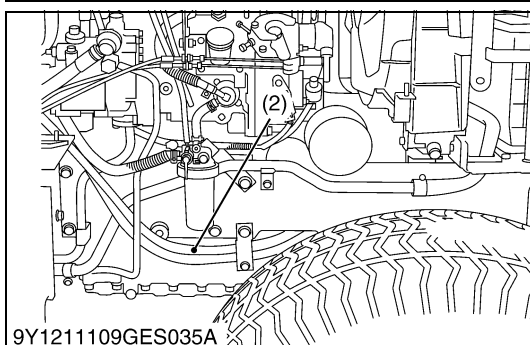

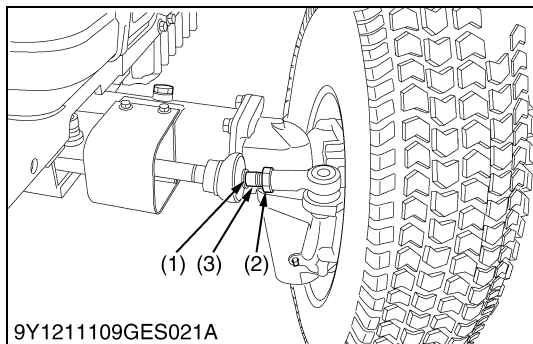
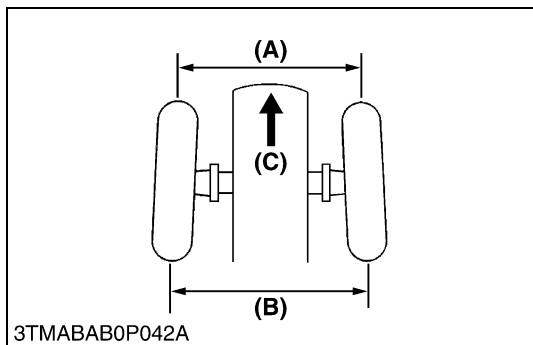

**Adjusting Toe-in**

1. Park the tractor on the flat place.
2. Inflate the tires to the specified pressure.
3. Turn steering wheel so front wheels are in the straight ahead position.
4. Lower the implement, lock the parking brake and stop the engine.
5. Measure distance between tire beads at front of tire, hub height.
6. Measure distance between tire beads at rear of tire, hub height.
7. Front distance should be 2 to 8 mm (0.079 to 0.315 in.) less than rear distance.
8. If the measurement is not within the factory specifications, adjust by changing the tie-rod length.

Toe-in ((B) - (A))	Factory specification	2 to 8 mm 0.079 to 0.315 in.
--------------------	-----------------------	---------------------------------

**Adjusting**

1. Detach the snap ring (1) from the dust cover.
2. Loosen the tie-rod lock nut (2) and turn the tie-rod joint (3) to adjust the tie-rod length until the proper toe-in measurement is obtained.
3. Retighten the tie-rod lock nut (2).
4. Attach the snap ring (1) to the dust cover.

Tightening torque	Tie-rod lock nut	117 to 137 N·m 12.0 to 14.0 Kgf·m 86.1 to 101.3 lbf·ft
-------------------	------------------	--

**IMPORTANT**

- A right and left tie-rod joint is adjusted to the same length.

- |                        |                                      |
|------------------------|--------------------------------------|
| (1) Snap Ring          | (A) Wheel to Wheel Distance at Front |
| (2) Tie-rod Lock Nut   | (B) Wheel to Wheel Distance at Rear  |
| (3) Tie-rod Lock Joint | (C) Front                            |

9Y1211109GEG0027US0

**Adjusting Air-Conditioner Belt Tension [CAB Model]**

**WARNING**

To avoid personal injury or death:

- Be sure to stop the engine before checking belt tension.

Proper air conditioner belt tension	A deflection of between 14 to 16 mm (0.56 to 0.62 in.) when the belt is pressed (98 N [10 kgf]) in the middle of the span.
-------------------------------------	--

1. Stop the engine and remove the key.
2. Apply moderate thumb pressure to belt between pulleys.
3. If tension is incorrect, loosen the lock nut and turn the adjusting bolt to adjust the belt tension within acceptable limits.
4. Replace air-conditioner belt if it is damaged.

- |                    |                                  |
|--------------------|----------------------------------|
| (1) Adjusting Bolt | <b>A: Check the Belt Tension</b> |
| (2) Lock Nut       |                                  |

9Y1211109GEG0079US0

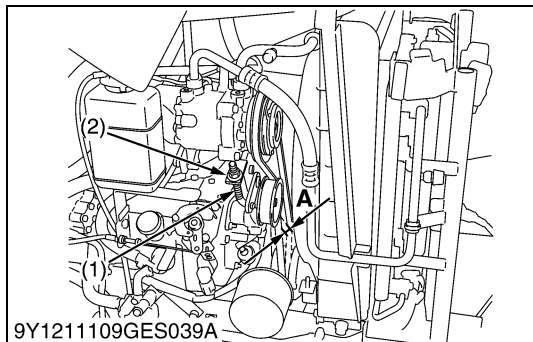

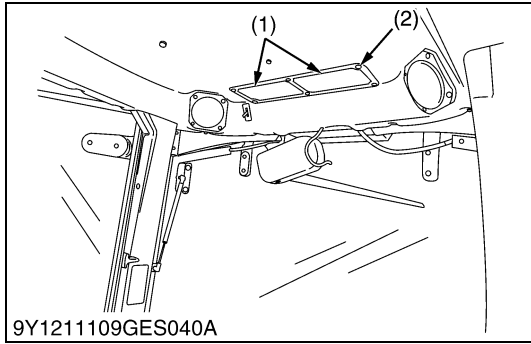

**Cleaning Inner Air Filter [CAB Model]**

Remove the inner filter, and blow air from the direction opposite to the filter's normal air flow.

Pressure of compressed air must be under 205 kPa (2.1 kgf/cm<sup>2</sup>, 30 psi).

- (1) Inner Air Filter
- (2) Screw

9Y1211109GEG0080US0

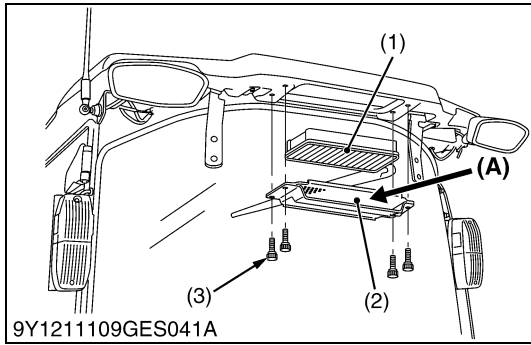

**Cleaning Fresh Air Filter [CAB Model]**

Remove the knob bolts and pull out filter.

■ **NOTE**

- Attach the filter and cover as the illustration above.

■ **Cleaning the air filter**

- Normal use

Blow air from the opposite direction to the filter's normal air flow. Pressure of compressed air must be under 205 kPa (2.1 kgf/cm<sup>2</sup>, 30 psi).

■ **IMPORTANT**

- Do not hit the filter. If the filter becomes deformed, dust may enter into the air-conditioner, which may cause damage and malfunction.

■ **NOTE**

- If the filter is very dirty:

Dip the filter in lukewarm water with mild dish washing detergent. Move it up and down as well as left and right to loosen dirt. Rinse the filter with clean water and let it air-dry.

■ **IMPORTANT**

- Do not use gasoline, thinner or similar chemicals to clean the filter as damage to the filter may occur.
- It may also cause an unpleasant odor in the CAB when the system is used next.

- (1) Fresh Air Filter
- (2) Cover
- (3) Knob Bolt
- (A) Air Inlet Port
- (B) "AIR CONDITIONER AIRFLOW"

9Y1211109GEG0081US0

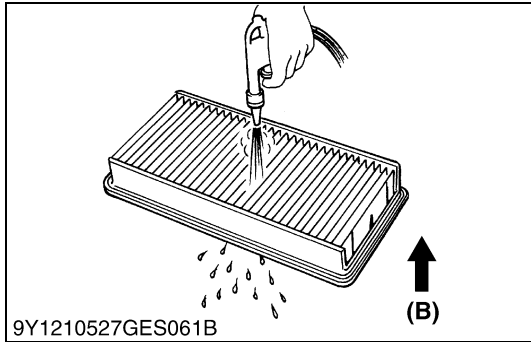

**Checking Air Conditioner Condenser [CAB Model]**

Check air conditioner condenser to be sure it is clean of debris.

- (1) Air Conditioner Condenser

9Y1211109GEG0082US0

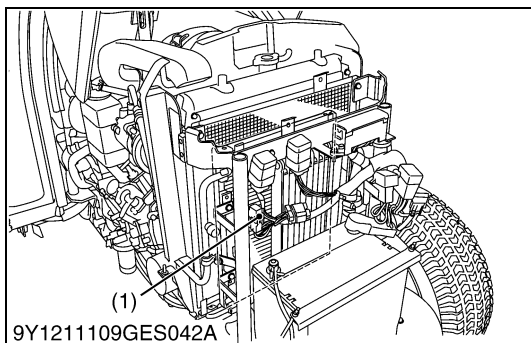

## [6] CHECK POINTS OF EVERY 400 HOURS

### Replacing Hydraulic Oil Filter Cartridge

- See page G-19.

9Y1211109GEG0028US0

### Replacing Fuel Filter Element

- See page G-25.

9Y1211109GEG0029US0

### Changing Transmission Fluid / Replacing hydraulic Oil Filter

- See page G-18.

9Y1211109GEG0083US0

### Changing Front Axle Case Oil

1. To drain the used oil, remove the right and left drain plugs and filling plug at the front axle case and drain the oil completely into the oil pan.
2. After draining reinstall the drain plugs.
3. Fill with the new oil.  
(Refer to "4. LUBRICANTS, FUEL AND COOLANT" on page G-8.)
4. After filling reinstall the filling plug.

#### ■ NOTE

- Make sure the oil level is at the center of the front axle.

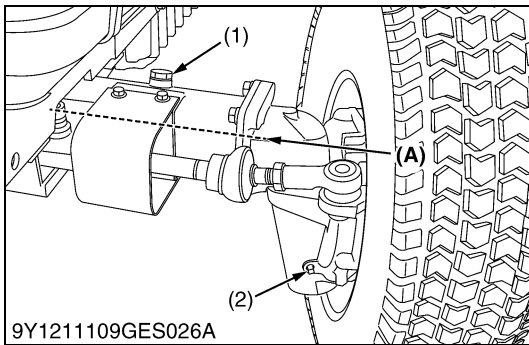

Front axle case oil	Capacity	4.5 L 4.8 U.S.qts 4.0 Imp.qts
---------------------	----------	-------------------------------------

- (1) Filling plug
- (2) Drain plug

(A) Oil level

9Y1211109GEG0031US0

## [7] CHECK POINT OF EVERY 600 HOURS

### Adjusting Front Axle Pivot

If the front axle pivot pin adjustment is not correct, front wheel vibration can occur causing vibration in the steering wheel.

#### ■ Adjusting procedure

Loosen the lock nut, screw-in the adjusting screw until seated, then tighten the screw with an additional 1/6 turn.

Re-tighten the lock nut.

- (1) Adjusting Screw

(2) Lock Nut

9Y1211109GEG0032US0

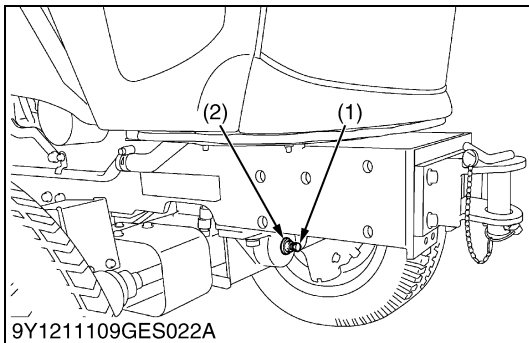

## [8] CHECK POINT OF EVERY 800 HOURS

### Checking Valve Clearance

- See page 1-S14.

9Y1211109GEG0033US0

## [9] CHECK POINTS OF EVERY 1 YEAR

### Replacing Air Cleaner Element (Primary) and Secondary Element

- See page G-24.

9Y1211109GEG0034US0

### Checking Air Conditioner Pipes and Hoses [CAB Model]

- See page G-32.

9Y1211109GEG0084US0

**Checking CAB Isolation Cushion [CAB Model]**

1. Check the cushion for any breakage or fatigue. Replace them if they are deteriorated.

9Y1211109GEG0076US0

**[10] CHECK POINTS OF EVERY 2 YEARS****Replacing Radiator Hose (Water Pipes)**

1. Replace the hoses and clamps.  
Refer to "Checking Radiator Hose and Hose Clamp". (See page G-30.)

9Y1211109GEG0035US0

**Replacing Fuel Hose**

1. Replace the fuel hoses and clamps, if necessary.  
Refer to "Checking Fuel Line". (See page G-26.)

9Y1211109GEG0036US0

**Replacing Power Steering Hoses**

1. Replace the hoses and clamps.  
Refer to "Checking HST Oil Line and Power Steering Hose".  
(See page G-30.)

9Y1211109GEG0037US0

**Replacing HST Oil Line**

1. Replace the hoses and clamps.  
Refer to "Checking HST Oil Line and Power Steering Hose".  
(See page G-30.)

9Y1211109GEG0038US0

**Replacing Air Conditioner Pipes and Hoses [CAB Model]**

- See page 10-S49, 10-S51.

9Y1211109GEG0085US0

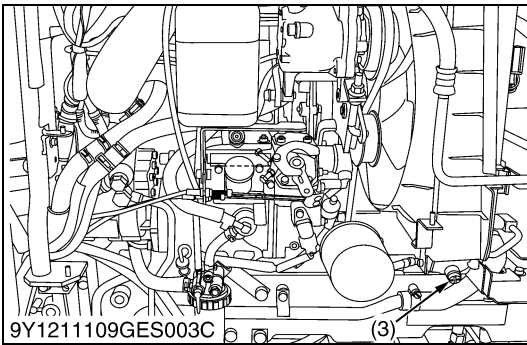
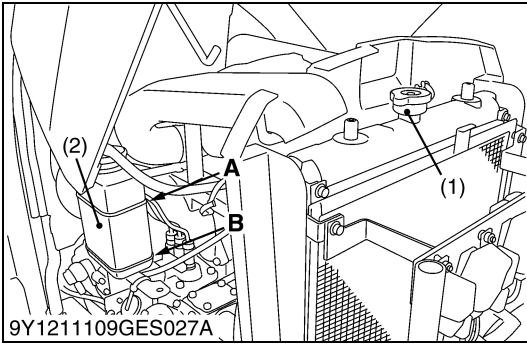

**Flush Cooling System and Changing Coolant**

**⚠ WARNING**

To avoid personal injury or death:

- Do not remove radiator cap while coolant is hot. When cool, slowly rotate cap to the first stop and allow sufficient time for excess pressure to escape before removing the cap completely.

1. Stop the engine, remove the key and let it cool down.
2. To drain the coolant, open the radiator drain plug and remove radiator cap. The radiator cap must be removed to completely drain the coolant.
3. After all coolant is drained, reinstall the drain plug.
4. Fill with clean soft water and cooling system cleaner.
5. Follow directions of the cleaner instruction.
6. After flushing, fill with clean soft water and anti-freeze until the coolant level is just below the radiator cap. Install the radiator cap securely.
7. Fill with coolant up to the "FULL" mark of recovery tank.
8. Start and operate the engine for few minutes.
9. Stop the engine, remove the key and let cool.
10. Check coolant level of recovery tank and add coolant if necessary.
11. Properly dispose of used coolant.

**■ IMPORTANT**

- Do not start engine without coolant.
- Use clean, fresh soft water and anti-freeze to fill the radiator and recovery tank.
- When mixing the anti-freeze with water, the anti-freeze mixing ratio is 50 %.
- Securely tighten radiator cap. If the cap is loose or improperly fitted, water may leak out and the engine could overheat.

**■ NOTE**

- On cab type machines, coolant circulates through the heater. This means that one more liter or so of coolant is required.

In changing coolant, pour coolant up to the filler port of the recovery tank. Turn ON the heater (shift the temperature control dial toward WARM), and run the engine for a while in order to warm coolant. Then stop the engine.

When coolant has cooled down, some of the coolant in the recovery tank is sucked. Now the recovery tank is appropriately filled with coolant.

Coolant (with recovery tank)	Capacity	ROPS	6.6 L 7.0 U.S.qts 5.8 Imp.qts
		CABIN	7.1 L 7.5 U.S.qts 6.2 Imp.qts

- (1) Radiator Cap **A: FULL**
- (2) Recovery Tank **B: LOW**
- (3) Drain Plug

**(To be continued)**

(Continued)

## ■ Anti-Freeze



### WARNING

To avoid personal injury or death:

- When using antifreeze, put on some protection such as rubber gloves (Antifreeze contains poison.).
- If it is swallowed, seek immediate medical help.  
Do NOT make a person throw up unless told to do so by poison control or a health care professional. Use standard first aid and CPR for signs of shock or cardiac arrest. Call your local Poison Control Center or your local emergency number for further assistance.
- When antifreeze comes in contact with the skin or clothing, wash it off immediately.
- Do not mix different types of Antifreeze.  
The mixture can produce chemical reaction causing harmful substances.
- Antifreeze is extremely flammable and explosive under certain conditions. Keep fire and children away from antifreeze.
- When draining fluids from the engine, place some container underneath the engine body.
- Do not pour waste onto the grounds, down a drain, or into any water source.
- Also, observe the relevant environmental protection regulations when disposing of antifreeze.

Always use a 50/50 mix of long-life coolant and clean soft water in KUBOTA engines.

1. Long-life coolant (hereafter LLC) comes in several types. Use ethylene glycol (EG) type for this engine.
2. Before employing LLC-mixed cooling water, fill the radiator with fresh water and empty it again.  
Repeat this procedure 2 or 3 times to clean up the inside.
3. Mixing the LLC  
Premix 50 % LLC with 50% clean soft water. When mixing, stir it up well, and then fill into the radiator.
4. The procedure for the mixing of water and antifreeze differs according to the make of the antifreeze and the ambient temperature. Refer to SAE J1034 standard, more specifically also to SAE J814c.
5. Adding the LLC
  - (1) Add only water if the mixture reduces in amount by evaporation.
  - (2) If there is a mixture leak, add the LLC of the same manufacturer and type in the same mixture percentage.  
\*Never add any long-life coolant of different manufacturer. (Different brands may have different additive components, and the engine may fail to perform as specified.)
6. When the LLC is mixed, do not employ any radiator cleaning agent. The LLC contains anticorrosive agent.  
If mixed with the cleaning agent, sludge may build up, adversely affecting the engine parts.
7. Kubota's genuine long-life coolant has a service life of 2 years. Be sure to change the coolant every 2 years.

**(To be continued)**

(Continued)

Vol % Anti-freeze	Freezing Point		Boiling Point*	
	°C	°F	°C	°F
50	-37	-34	108	226

\* At  $1.013 \times 10^5$  Pa (760 mmHg) pressure (atmospheric). A higher boiling point is obtained by using a radiator pressure cap which permits the development of pressure within the cooling system.

■ **NOTE**

- **The above data represent industry standards that necessitate a minimum glycol content in the concentrated antifreeze.**

9Y1211109GEG0039US0

## [11] OTHERS

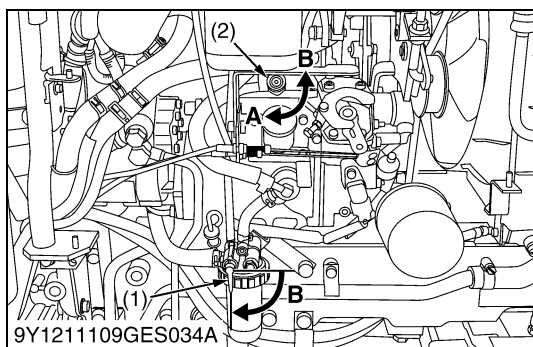

### Bleeding Fuel System

Air must be removed:

1. When the fuel filter or lines are removed.
2. When tank is completely empty.
3. After the tractor has not been used for a long period of time.



**CAUTION**

- **Do not bleed the fuel system when the engine is hot.**  
Bleeding procedure is as follows:

1. Fill the fuel tank with fuel, and open the fuel valve (1).
2. Open the air vent valve (2) on the fuel injection pump.
3. Start the engine and run for about 30 seconds, and then stop the engine.
4. Close the air vent valve.

■ **IMPORTANT**

- **Always close the air vent valve (2) except for bleeding fuel lines. Otherwise, engine runs irregularly or stalls frequently.**

- |                    |                 |
|--------------------|-----------------|
| (1) Fuel Valve     | <b>A: CLOSE</b> |
| (2) Air Vent Valve | <b>B: OPEN</b>  |

9Y1211109GEG0040US0

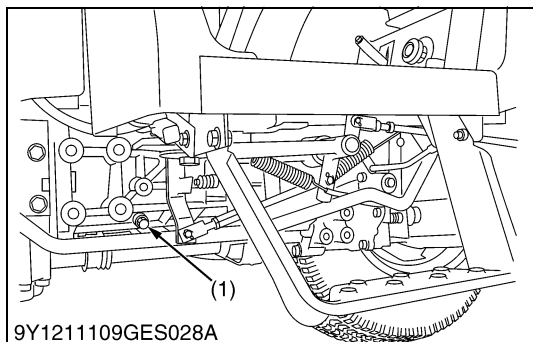

### Draining Clutch Housing Water

■ **NOTE**

- **The tractor is equipped with water drain plug (1) under the clutch housing.**
- **After operating in rain, snow or tractor has been washed, water may get into the clutch housing.**

1. Remove the water drain plug (1) and drain the water, then install the plug again.

- (1) Water Drain Plug

9Y1211109GEG0041US0



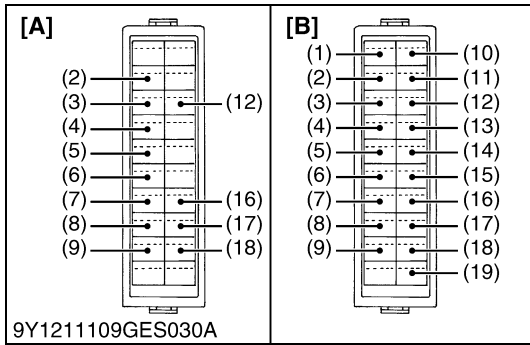
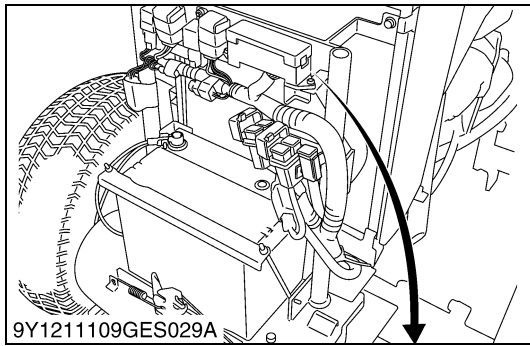

**Replacing Fuse**

1. The tractor electrical system is protected from potential damage by fuses.  
A blown fuse indicates that there is an overload or short somewhere in the electrical system.
2. If any of the fuses should blow, replace with a new one of the same capacity.

■ **IMPORTANT**

- Before replacing a blown fuse, determine why the fuse blew and make any necessary repairs. Failure to follow this procedure may result in serious damage to the tractor electrical system. Refer to troubleshooting section of this manual.

■ **Protected circuit**

FUSE No.	Capacity (A)	Protected circuit	ROPS [A]	CAB [B]
(1)	15	Work light	–	○
(2)	ROPS 10A	Electrical outlet	○	○
	CAB 30A		○	○
(3)	5	Lamp relay	○	○
(4)	5	Key stop	○	○
(5)	10	Controller (Ignition)	○	○
(6)	10	Alternator	○	○
(7)	10	Brake lamp	○	○
(8)	10	Beacon lamp	○	○
(9)	15	Hazard light	○	○
(10)	7.5	Air conditioner compressor	–	○
(11)	15	Wiper	–	○
(12)	30	Starter	○	○
(13)	20	Defogger	–	○
(14)	5	Radio (Battery)	–	○
(15)	20	Air conditioner blower	–	○
(16)	30	Head light	○	○
(17)	5	Instrument panel (Battery)	○	○
(18)	5	Controller (Battery)	○	○
(19)	7.5	Radio (ACC)	–	○

9Y1211109GEG0042US0

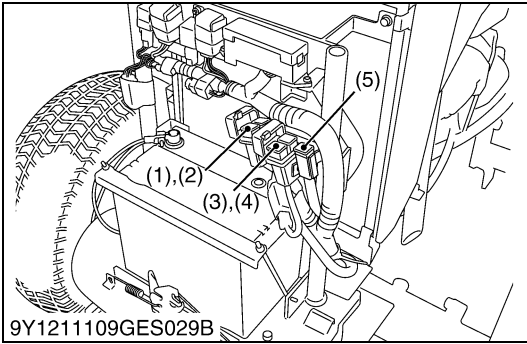

**Replacing Slow-Blow Fuses**

The slow-blow fuses are intended to protect the electrical cabling. If any of them has blown out, be sure to pinpoint the cause. Never use any substitute, use only a KUBOTA genuine part.

**[ROPS model]**

FUSE No.	Capacity (A)	Protected circuit
(1)	40	Glow
(2)	40	Key stop
(3)	40	Main switch
(4)	50	Main

**[CAB model]**

FUSE No.	Capacity (A)	Protected circuit
(1)	40	Glow
(2)	40	Key stop
(3)	30	Electrical outlet
(4)	40	Main switch
(5)	50	Main

9Y1211109GEG0043US0

**Replacing Light**

1. Head lights and rear combination lights.  
Take the bulb out of the light body and replace with a new one.
2. Other light:  
Detach the lens and replace the bulb.

Light	Capacity
Head lights	45 W /40 W
Tail light	5 W
Brake stop light	21 W
Turn signal / Hazard light	21 W
Front position light	5 W
Dome light	5 W
Work light (if equipped)	35 W
Number plate light	10 W

9Y1211109GEG0044US0

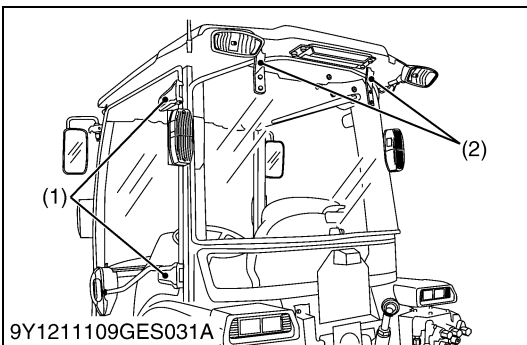

**Lubricating Points [CAB Model]**

- (1) Door Hinge
- (2) Rear Window Hinge

9Y1211109GEG0046US0

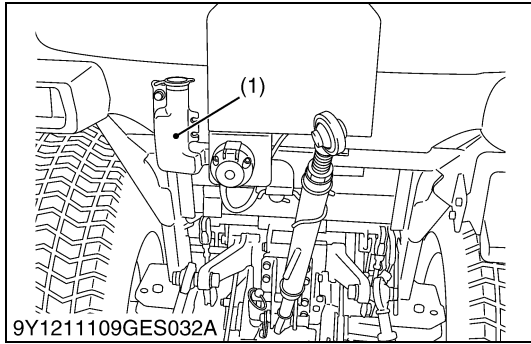

**Adding Washer Liquid [CAB Model]**

Add a proper amount of automobile washer liquid.

Washer tank	Capacity	1.2 L 1.3 U.S.qts 1.1 Imp.qts
-------------	----------	-------------------------------------

(1) Washer Liquid Tank

9Y1211109GEG0047US0

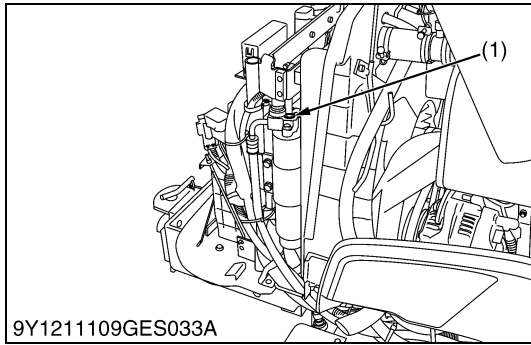

**Checking the Amount of Refrigerant (Gas) [CAB Model]**

**⚠ WARNING**

To avoid personal injury or death:

- Liquid contact with eyes or skin may cause frostbite.
- In the event of a leakage, wear safety goggles. Escaping refrigerant can cause severe injuries to eyes.
- In contact with a flame, R134a refrigerant gives a toxic gas.
- Do not disconnect any part of the refrigeration circuit of the air conditioning system.

A shortage of refrigerant impairs the air-conditioner performance. Check the following points. If it is indicated that the amount of refrigerant is extremely low, ask your dealer to inspect and charge.

■ **Checking procedure**

1. Run the air-conditioner in the following conditions.
  - Engine speed: About 1500 min<sup>-1</sup> (rpm)
  - Temperature control dial: Maximum cooling position
  - Fan switch: Highest blow (HI)
  - Air-conditioner switch: ON
2. Look into the sight glass to see if the refrigerant is flowing through its circuit.

■ **IMPORTANT**

- Charge only with R134a not R12 refrigerant (gas).

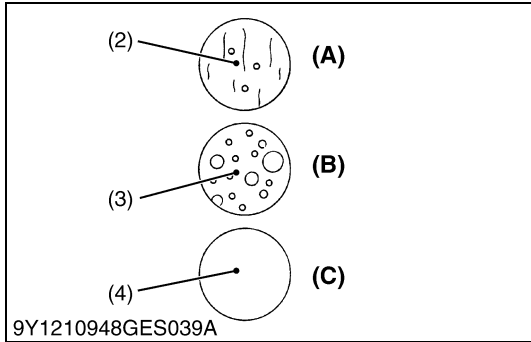

- (1) Sight Glass
- (2) Proper
- (3) Low
- (4) Overfull or No Refrigerant

- (A) Little or no air bubbles in the refrigerant flow.
- (B) Lots of air bubbles in the refrigerant flow (air bubbles or foam passing continuously).
- (C) Colorless and transparent.

9Y1211109GEG0048US0

# 8. SPECIAL TOOLS

## [1] SPECIAL TOOLS FOR ENGINE

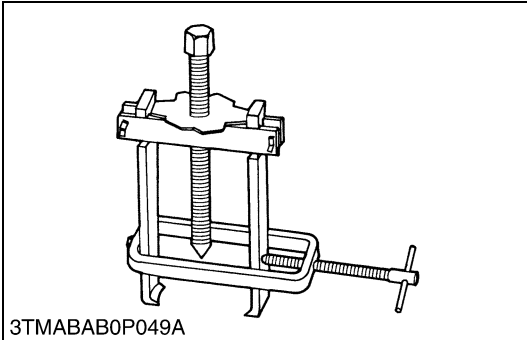

3TMABAB0P049A

### Special Use Puller Set

**Code No.**

- 07916-09032

**Application**

- Use exclusively to pull out bearing, gears and other parts with ease.

WSM000001GEG0011US0

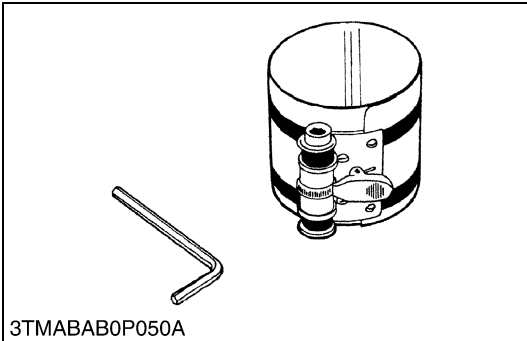

3TMABAB0P050A

### Piston Ring Compressor

**Code No.**

- 07909-32111

**Application**

- Use exclusively to push in the piston with piston rings into the cylinder.

WSM000001GEG0012US0

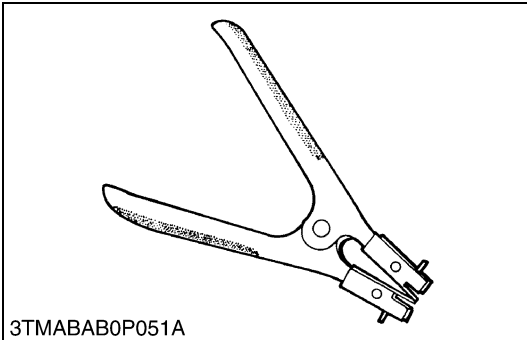

3TMABAB0P051A

### Piston Ring Tool

**Code No.**

- 07909-32121

**Application**

- Use exclusively to remove or install the piston ring with ease.

WSM000001GEG0013US0

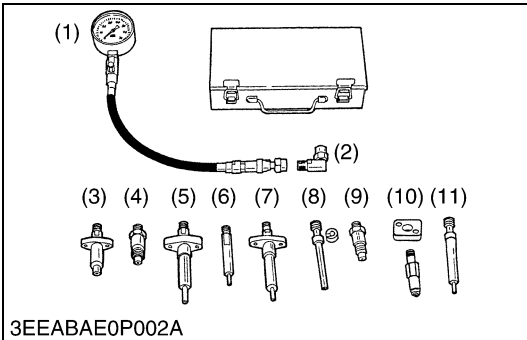

3EEABAE0P002A

### Diesel Engine Compression Tester (for Injection Nozzle)

**Code No.**

- 07909-30208 (Assembly)
- 07909-30934 (A to F)
- 07909-31211 (E and F)
- 07909-31231 (H)
- 07909-31251 (G)
- 07909-31271 (I)
- 07909-31281 (J)

**Application**

- Use to measure diesel engine compression and diagnostics of need for major overhaul.

- |               |                |
|---------------|----------------|
| (1) Gauge     | (7) Adaptor F  |
| (2) L Joint   | (8) Adaptor G  |
| (3) Adaptor A | (9) Adaptor H  |
| (4) Adaptor B | (10) Adaptor I |
| (5) Adaptor C | (11) Adaptor J |
| (6) Adaptor E |                |

WSM000001GEG0014US0

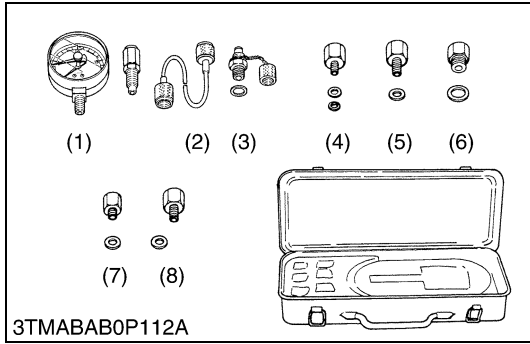

**Oil Pressure Tester**

- Code No.**  
 • 07916-32032

**Application**  
 • Use to measure lubricating oil pressure.

- |                    |               |
|--------------------|---------------|
| (1) Gauge          | (5) Adaptor 2 |
| (2) Cable          | (6) Adaptor 3 |
| (3) Threaded Joint | (7) Adaptor 4 |
| (4) Adaptor 1      | (8) Adaptor 5 |

WSM000001GEG0015US0

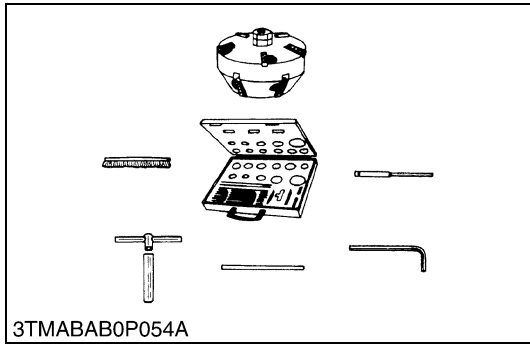

**Valve Seat Cutter**

- Code No.**  
 • 07909-33102

**Application**  
 • Use to reseal valves.

- Angle**  
 • 0.79 rad (45 °)  
 • 0.26 rad (15 °)

- Diameter**  
 • 28.6 mm (1.13 in.)  
 • 31.6 mm (1.24 in.)  
 • 35.0 mm (1.38 in.)  
 • 38.0 mm (1.50 in.)  
 • 41.3 mm (1.63 in.)  
 • 50.8 mm (2.00 in.)

WSM000001GEG0016US0

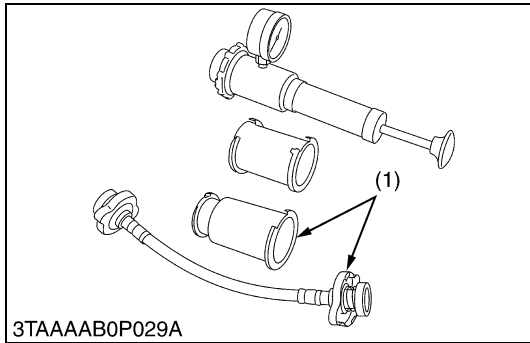

**Radiator Tester**

- Code No.**  
 • 07909-31551

**Application**  
 • Use to check of radiator cap pressure, and leaks from cooling system.

**Remarks**  
 • Adaptor (1) BANZAI Code No. RCT-2A-30S.

- (1) Adaptor

WSM000001GEG0017US0

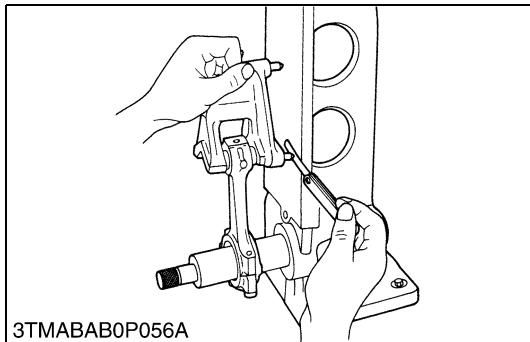

**Connecting Rod Alignment Tool**

- Code No.**  
 • 07909-31661

**Application**  
 • Use to check the connecting rod alignment.

- Applicable range**  
 • Connecting rod big end I.D.  
 30 to 75 mm dia. (1.2 to 2.9 in. dia.)  
 • Connecting rod length  
 65.0 to 300 mm (2.56 to 11.8 in.)

WSM000001GEG0020US0

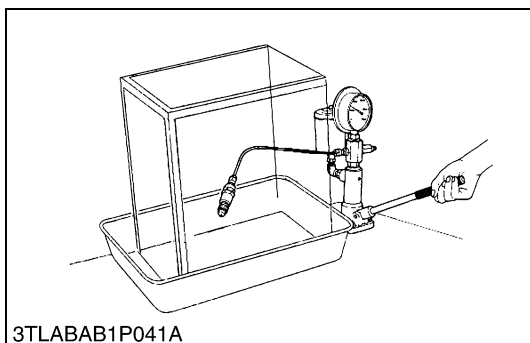

**Nozzle Tester**

- Code No.**  
 • 07909-31361

**Application**  
 • Use to check the fuel injection pressure and spray pattern of nozzle.

- Measuring range**  
 • 0 to 50 MPa (0 to 500 kgf/cm<sup>2</sup>, 0 to 7200 psi)

WSM000001GEG0021US0

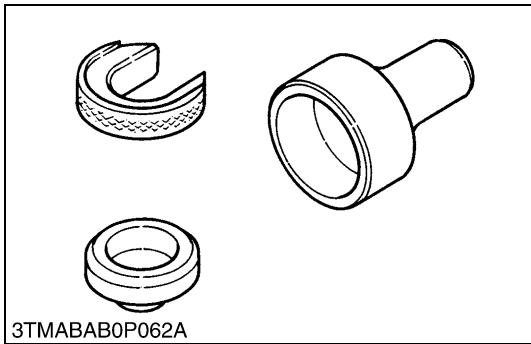

**Auxiliary Socket For Fixing Crankshaft Sleeve**

**Code No.**

- 07916-32091

**Application**

- Use to fix the crankshaft sleeve of the diesel engine.

WSM000001GEG0095US0

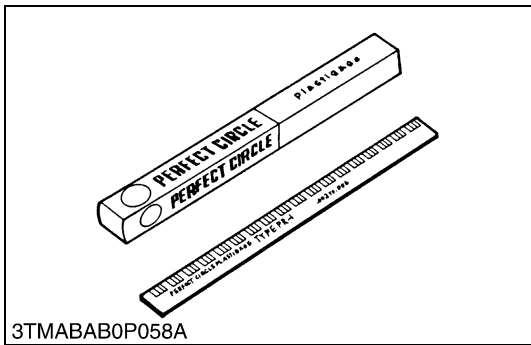

**Plastigauge**

**Code No.**

- 07909-30241

**Application**

- Use to check the oil clearance between crankshaft and bearing, etc..

**Measuring range**

- Green: 0.03 to 0.07 mm (0.001 to 0.003 in.)
- Red: 0.05 to 0.1 mm (0.002 to 0.006 in.)
- Blue: 0.1 to 0.2 mm (0.004 to 0.009 in.)

WSM000001GEG0022US0

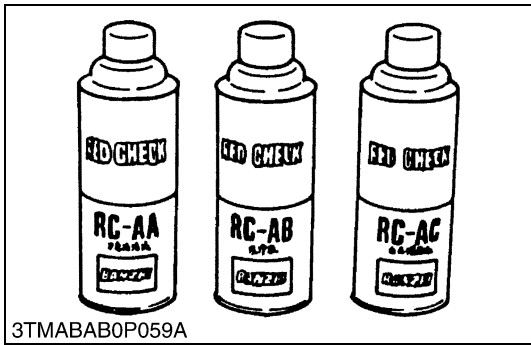

**Red Check**

**Code No.**

- 07909-31371

**Application**

- Use to check cracks on cylinder head, cylinder block, etc..

WSM000001GEG0023US0

**NOTE**

- The following special tools are not provided, so make them referring to the figure.

9Y1211109GEG0050US0

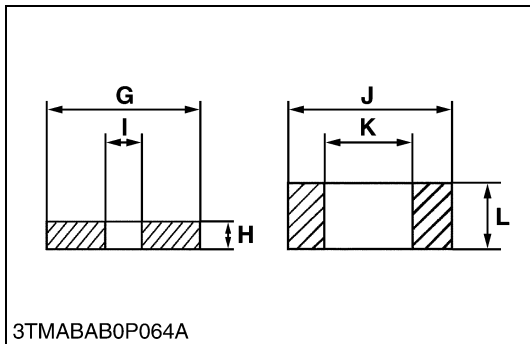
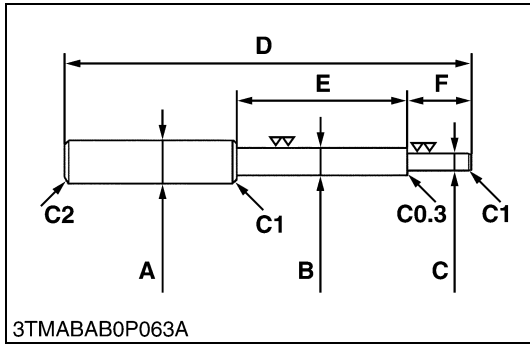

**Valve Guide Replacing Tool**

**Application**

- Use to press out and press fit the valve guide.

<b>A</b>	20 mm dia. (0.79 in. dia.)
<b>B</b>	11.7 to 11.9 mm dia. (0.460 to 0.468 in. dia.)
<b>C</b>	6.5 to 6.6 mm dia. (0.256 to 0.259 in. dia.)
<b>D</b>	225 mm (8.86 in.)
<b>E</b>	70 mm (2.76 in.)
<b>F</b>	45 mm (1.77 in.)
<b>G</b>	25 mm dia. (0.98 in. dia.)
<b>H</b>	5 mm (0.197 in.)
<b>I</b>	6.7 to 7.0 mm dia. (0.263 to 0.275 in. dia.)
<b>J</b>	20 mm dia. (0.787 in. dia.)
<b>K</b>	12.5 to 12.8 mm dia. (0.492 to 0.504 in. dia.)
<b>L</b>	8.9 to 9.1 mm (0.350 to 0.358 in.)
<b>C1</b>	Chamfer 1.0 mm (0.039 in.)
<b>C2</b>	Chamfer 2.0 mm (0.079 in.)
<b>C0.3</b>	Chamfer 0.3 mm (0.012 in.)

9Y1211109GEG0051US0

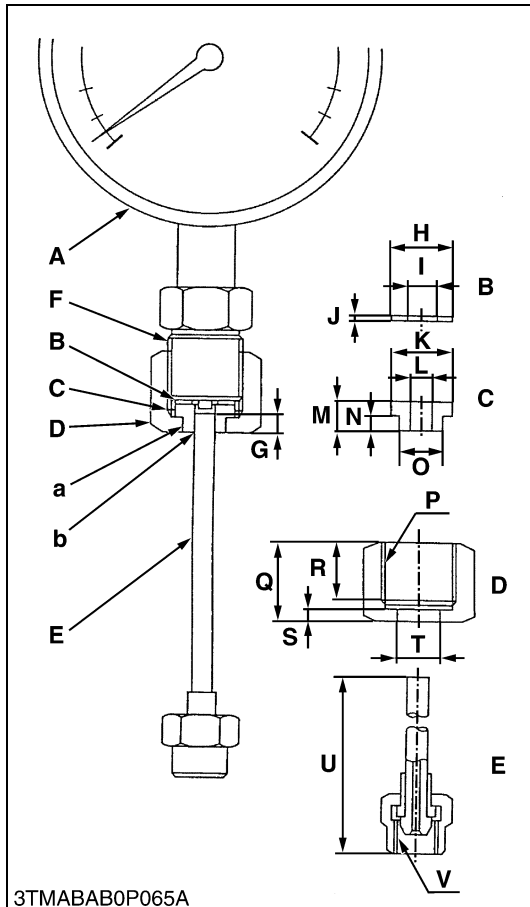

3TMABAB0P065A

### Injection Pump Pressure Tester

#### Application

- Use to check fuel tightness of injection pumps.

A	Pressure gauge full scale: More than 29.4 MPa (300 kgf/cm <sup>2</sup> , 4267 psi)
B	Copper gasket
C	Flange (Material: Steel)
D	Hex. nut 27 mm (1.06 in.) across the plat
E	Injection pipe
F	PF 1/2
G	5 mm (0.20 in.)
H	17 mm dia. (0.67 in. dia.)
I	8 mm dia. (0.31 in. dia.)
J	1.0 mm (0.039 in.)
K	17 mm dia. (0.67 in. dia.)
L	6.10 to 6.20 mm dia. (0.2402 to 0.2441 in. dia.)
M	8 mm (0.31 in.)
N	4 mm (0.16 in.)
O	11.97 to 11.99 mm dia. (0.4713 to 0.4721 in. dia.)
P	PF 1/2
Q	23 mm (0.91 in.)
R	17 mm (0.67 in.)
S	4 mm (0.16 in.)
T	12.00 to 12.02 mm dia. (0.4724 to 0.4732 in. dia.)
U	100 mm (3.94 in.)
V	M12 × P1.5
a	Adhesive application
b	Fillet welding on the enter circumference

9Y1211109GEG0052US0

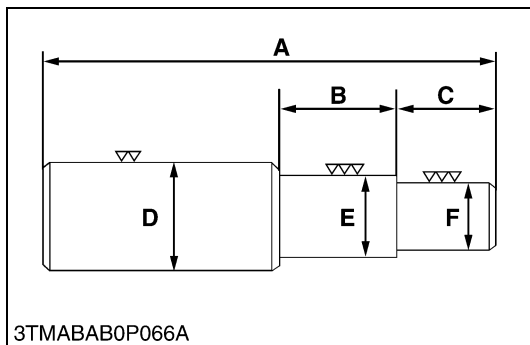

3TMABAB0P066A

### Bushing Replacing Tools

#### Application

- Use to press out and press fit the bushing.

#### 1. For small end bushing

A	162 mm (6.38 in.)
B	35 mm (1.38 in.)
C	27 mm (1.06 in.)
D	35 mm dia. (1.38 in. dia.)
E	27.90 to 27.95 mm dia. (1.098 to 1.100 in. dia.)
F	25.00 to 25.01 mm dia. (0.984 to 0.985 in. dia.)

#### 2. For idle gear bushing

A	175 mm (6.89 in.)
B	40 mm (1.57 in.)
C	38 mm (1.49 in.)
D	45 mm dia. (1.77 in. dia.)
E	41.90 to 41.95 mm dia. (1.650 to 1.652 in. dia.)
F	37.95 to 37.97 mm dia. (1.494 to 1.495 in. dia.)

9Y1211109GEG0053US0



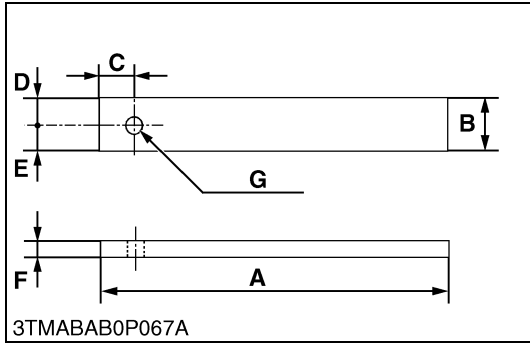

**Flywheel Stopper**

**Application**

- Use to loosen and tighten the flywheel screw.

<b>A</b>	200 mm (7.87 in.)
<b>B</b>	30 mm (1.18 in.)
<b>C</b>	20 mm (0.79 in.)
<b>D</b>	15 mm (0.59 in.)
<b>E</b>	5 mm (0.20 in.)
<b>F</b>	8 mm (0.31 in.)
<b>G</b>	10 mm dia. (0.39 in. dia.)

9Y1211109GEG0054US0

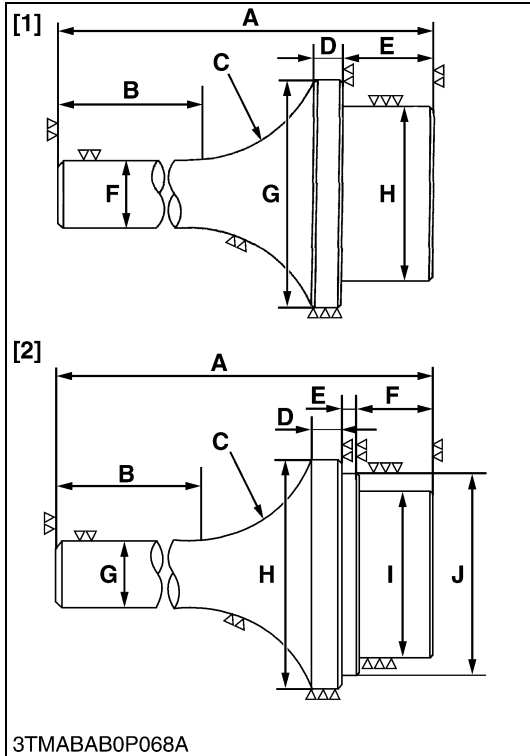

**Crankshaft Bearing 1 Replacing Tool**

**Application**

- Use to press out and press fit the crankshaft bearing 1.

**1. Extracting tool**

<b>A</b>	135 mm (5.31 in.)
<b>B</b>	72 mm (2.83 in.)
<b>C</b>	R40 mm (R1.57 in.)
<b>D</b>	10 mm (0.39 in.)
<b>E</b>	20 mm (0.79 in.)
<b>F</b>	20 mm dia. (0.79 in. dia.)
<b>G</b>	56.8 to 56.9 mm dia. (2.236 to 2.240 in. dia.)
<b>H</b>	51.8 to 51.9 mm dia. (2.039 to 2.043 in. dia.)

**2. Inserting tool**

<b>A</b>	130 mm (5.12 in.)
<b>B</b>	72 mm (2.83 in.)
<b>C</b>	R40 mm (R1.57 in.)
<b>D</b>	9 mm (0.35 in.)
<b>E</b>	4 mm (0.16 in.)
<b>F</b>	20 mm (0.79 in.)
<b>G</b>	20 mm dia. (0.79 in. dia.)
<b>H</b>	68 mm dia. (2.68 in. dia.)
<b>I</b>	51.8 to 51.9 mm dia. (2.039 to 2.043 in. dia.)
<b>J</b>	56.8 to 56.9 mm dia. (2.236 to 2.240 in. dia.)

9Y1211109GEG0055US0

## [2] SPECIAL TOOLS FOR TRACTOR

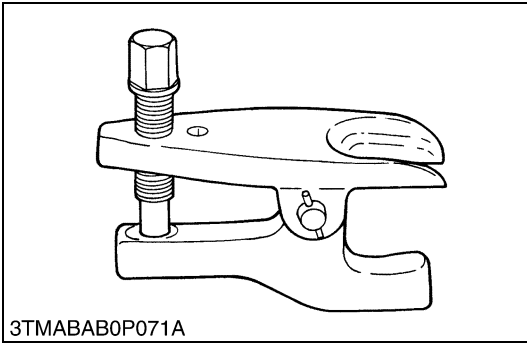

3TMABAB0P071A

### Tie-rod End Lifter

#### **Code No.**

- 07909-39051

#### **Application**

- Use to remove the tie-rod end with ease.

WSM000001GEG0029US0

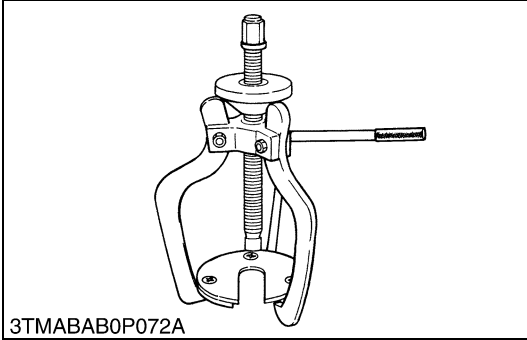

3TMABAB0P072A

### Steering Wheel Puller

#### **Code No.**

- 07916-51090

#### **Application**

- Use to remove the steering wheel without damage to the steering shaft.

WSM000001GEG0030US0

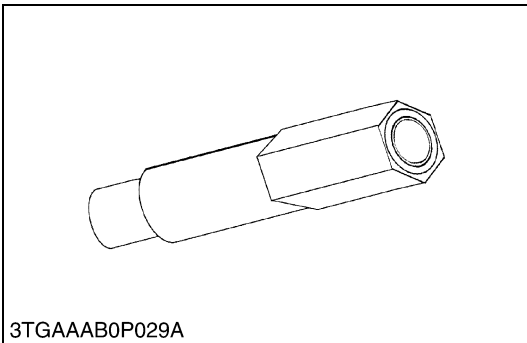

3TGAAAB0P029A

### Long Connector

#### **Code No.**

- 07916-60831

#### **Application**

- Use for checking HST Charge relief pressure.

9Y1211109GEG0056US0

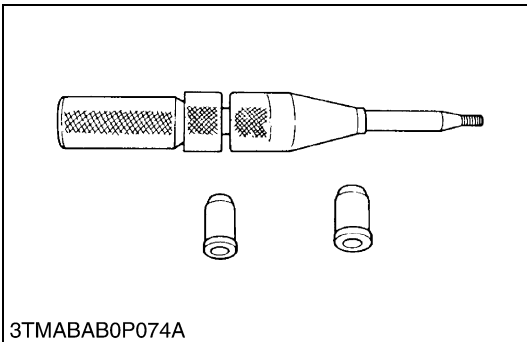

3TMABAB0P074A

### Clutch Center Tool (For B and L Series Tractors)

#### **Application**

- The clutch center tool is for all B and L series tractors with a diaphragm clutch by changing tip guides. Center piece diameter is 20 mm (0.79 in.).

WSM000001GEG0032US0

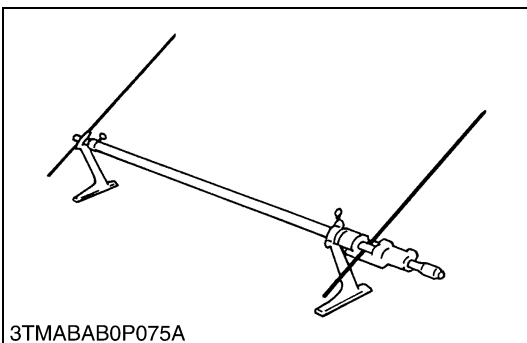

3TMABAB0P075A

### Toe-in Gauge

#### **Code No.**

- 07909-31681

#### **Application**

- This allows easy measurement of toe-in for all machine models.

WSM000001GEG0034US0

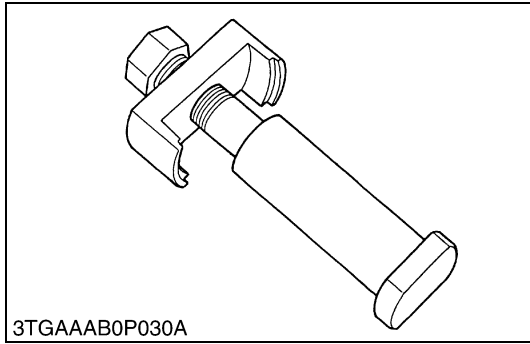

**Clutch Pack Disassembly Tool**

- Code No.**
- 07916-53741

- Application**
- This allows easy installation of bi-speed clutch pack spring.
- 9Y1211109GEG0057US0

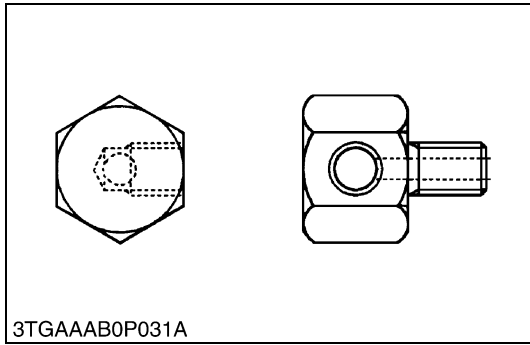

**Adaptor 7**

- Code No.**
- 07916-32951

- Application**
- Use for checking regulating valve setting pressure.
- 9Y1211109GEG0058US0

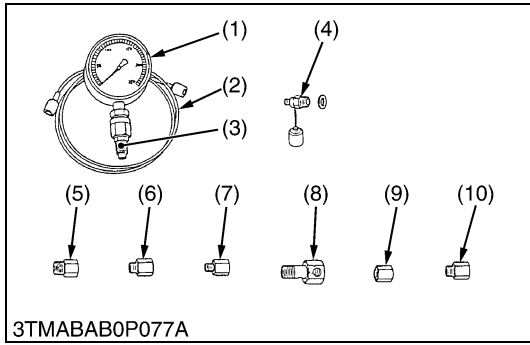

**Relief Valve Pressure Tester**

- Code No.**
- 07916-50045

- Application**
- This allows easy measurement of relief set pressure.

- |  |                                       |
|--|---------------------------------------|
| (1) Gauge (07916-50322)                  | (6) Adaptor C (PS3/8) (07916-50371)   |
| (2) Cable (07916-50331)                  | (7) Adaptor D (PT1/8) (07916-50381)   |
| (3) Threaded Joint (07916-50401)         | (8) Adaptor E (PS3/8) (07916-50392)   |
| (4) Threaded Joint (07916-50341)         | (9) Adaptor F (PF1/2) (07916-62601)   |
| (5) Adaptor B (M18 x P1.5) (07916-50361) | (10) Adaptor 58 (PT1/4) (07916-52391) |

WSM000001GEG0027US0

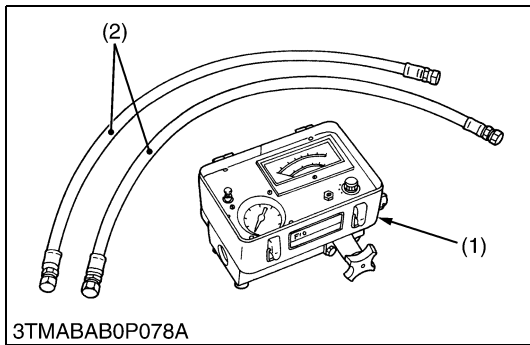

**Flow Meter**

- Code No.**
- 07916-52791 (Flow Meter)
  - 07916-52651 (Hydraulic Test Hose)

- Application**
- This allows easy testing of hydraulic system.

- |                |                         |
|----------------|-------------------------|
| (1) Flow Meter | (2) Hydraulic Test Hose |
|----------------|-------------------------|

WSM000001GEG0036US0

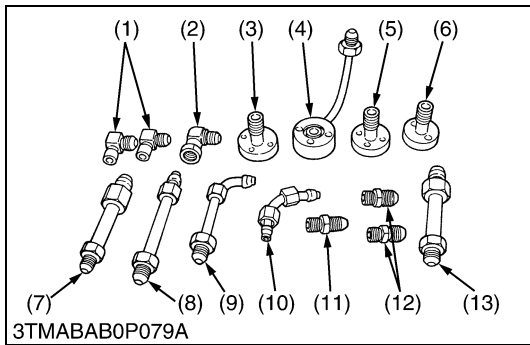

**Adaptor Set for Flow Meter**

- Code No.**
- 07916-54031

- Application**
- Use for test of the hydraulic system.

- |                |                          |
|----------------|--------------------------|
| (1) Adaptor 52 | (8) Adaptor 65           |
| (2) Adaptor 53 | (9) Adaptor 66           |
| (3) Adaptor 54 | (10) Adaptor 67          |
| (4) Adaptor 61 | (11) Adaptor 68          |
| (5) Adaptor 62 | (12) Adaptor 69          |
| (6) Adaptor 63 | (13) Hydraulic Adaptor 1 |
| (7) Adaptor 64 |                          |

WSM000001GEG0037US0

**NOTE**

- The following special tools are not provided, so make them referring to the figure.

9Y1211109GEG0059US0

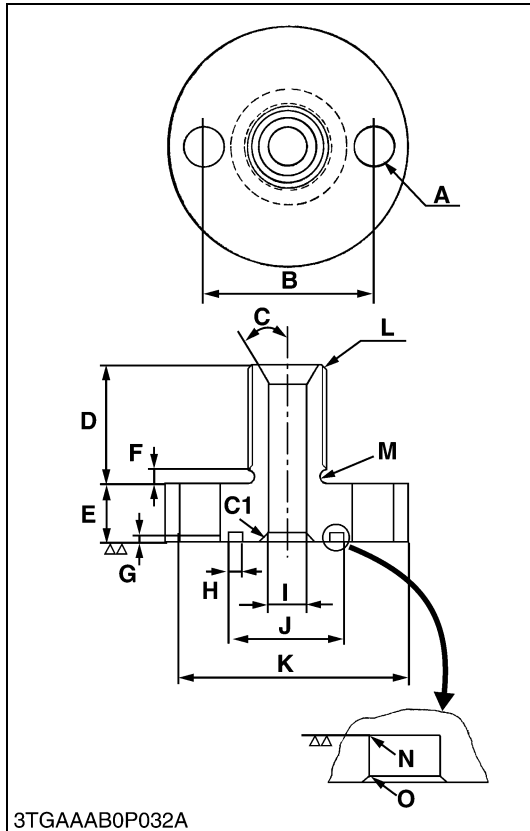

**Adaptor for Flow Meter**

**Application**

- Use for checking the hydraulic pump for 3P linkage.

**NOTE**

- When using, attach with following parts.  
O-ring: 04811-00180

A	2-8.5 mm dia. (2-0.334 in. dia.)
B	40 mm (1.57 in.)
C	0.52 rad (30 °)
D	25 mm (0.98 in.)
E	15 mm (0.59 in.)
F	3 mm (0.118 in.)
G	1.7 to 1.9 mm (0.067 to 0.075 in.)
H	3.0 to 3.25 mm (0.118 to 0.128 in.)
I	8.0 mm dia. (0.315 in. dia.)
J	23.9 to 24.1 mm dia. (0.941 to 0.945 in. dia.)
K	60 mm dia. (2.36 in. dia.)
L	PS 3/8
M	1.5 mm Round (0.059 in. Round)
N	0.3 mm Round (0.012 in. Round)
O	Chamfer 0.2 mm (0.0078 in.)

9Y1211109GEG0060US0

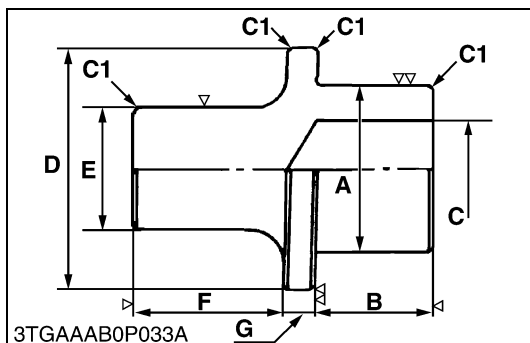

**Hydraulic Arm Shaft Bushing Replacing Tool**

**Application**

- Use for replacing the hydraulic arm shaft bushing in the hydraulic cylinder block.

	Right	Left
A	37.90 to 37.95 mm dia. (1.492 to 1.494 in. dia.)	34.90 to 34.95 mm dia. (1.374 to 1.376 in. dia.)
B	40 mm (1.575 in.)	35 mm (1.378 in.)
C	28 mm dia. (1.102 in. dia.)	25 mm dia. (0.984 in. dia.)
D	44.5 mm dia. (1.75 in. dia.)	
E	30 mm dia. (1.18 in. dia.)	
F	50 mm (1.97 in.)	
G	10 mm (0.39 in.)	

9Y1211109GEG0061US0

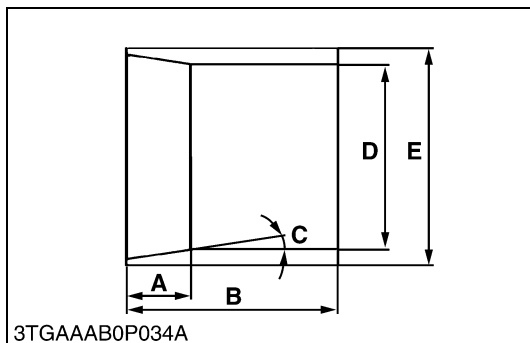

**Piston Gasket Correcting Tool**

**Application**

- Compress the power steering cylinder piston gasket to the correct side when install the cylinder rod to the cylinder tube with ease.

A	13.97 mm (0.55 in.)
B	35.052 mm (1.38 in.)
C	0.122 rad (7 °)
D	40.000 to 40.039 mm dia. (1.57 to 1.58 in. dia.)
E	46 mm dia. (1.82 in. dia.)

9Y1211109GEG0062US0

## 9. TIRES

### [1] TIRE PRESSURE



#### WARNING

To avoid personal injury or death:

- Do not attempt to mount a tire on a rim. This should be done by a qualified person with the proper equipment.
- Always maintain the correct tire pressure.  
Do not inflate tires above the recommended pressure shown in the operator's manual.

#### ■ IMPORTANT

- Do not use tires other than those approved by KUBOTA.

#### ■ Inflation Pressure

Though the tire pressure is factory-set to the prescribed level, it naturally drops slowly in the course of time. Thus, check it everyday and inflate as necessary.

#### ■ NOTE

- Maintain the maximum pressure in front tires, if using a front loader or when equipped with a full load of front weights.

	Tire sizes	Inflation pressure
Rear	9.5-22, 4PR	140 kPa (1.4 kgf/cm <sup>2</sup> , 19.9 psi)
	13.6-16, 4PR	100 kPa (1.0 kgf/cm <sup>2</sup> , 14.2 psi)
Front	6.00-12, 4PR	180 kPa (1.8 kgf/cm <sup>2</sup> , 25.6 psi)
	24 × 8.50-14, 4PR	160 kPa (1.6 kgf/cm <sup>2</sup> , 22.8 psi)

9Y1211109GEG0063US0

## [2] TREAD



### WARNING

To avoid personal injury or death:

- **A** When working on slopes or when working with trailer, set the wheel tread as wide as practical for maximum stability.
- Support tractor securely on stands before removing a wheel.
- Do not work under any hydraulically supported devices. They can settle, suddenly leak down, or be accidentally lowered. If necessary to work under tractor or any machine elements for servicing or adjustment, securely support them with stands or suitable blocking beforehand.
- Never operate tractor with a loose rim, wheel, or axle.

9Y1211109GEG0064US0

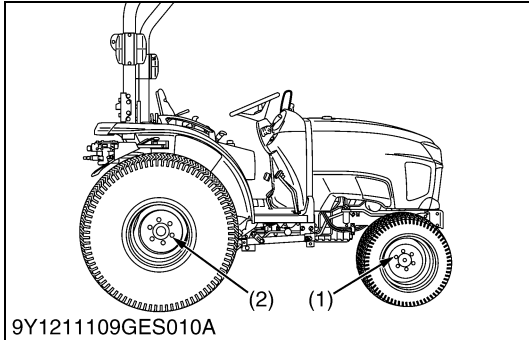

9Y1211109GES010A

### Wheel Tightening Screws and Nuts

#### ■ IMPORTANT

- Do not turn front discs to obtain wider tread.
  - When re-fitting or adjusting a wheel, tighten the bolts to the following torques then recheck after driving the tractor 200 m (219 yards) and 10 times of shuttle movement by 5 m (5 yards), and thereafter according to service interval.
1. When refitting or adjusting a wheel, tighten the screws and nuts with specified tightening torque.
  2. Recheck after driving the tractor 200 m (219 yards) and therefore according to service interval.

Tightening torque	Front wheel mounting screw and nut	85 N·m 9.0 kgf·m 65.1 lbf·ft
	Rear wheel mounting screw and nut	215 N·m 22.0 kgf·m 159.1 lbf·ft

(1) Front Wheel

(2) Rear Wheel

9Y1211109GEG0065US0

## (1) Front Wheels

Front wheel tread can not be adjusted.

### ■ IMPORTANT

- Do not turn front discs to obtain wider tread.
- When re-fitting or adjusting a wheel, tighten the bolts to the following torques then recheck after driving the tractor 200 m (219 yards) and 10 times of shuttle movement by 5 m (5 yards), and thereafter according to service interval.
- Do not turn front discs to obtain wider tread. In setting up the front wheels, make sure that the inflation valve stem of the tires face outward.

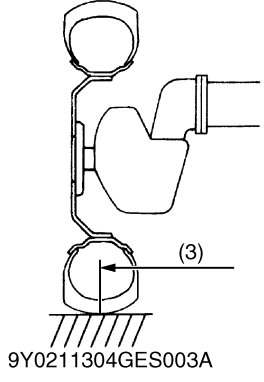
 <p>9Y0211304GES003A</p>	Models	STW34, STW37, STW40	
	Tires	6.00-12 Farm	24 × 8.50-14 Turf
	Tread	1020 mm (40.16 in.)	1020 mm (40.16 in.)

9Y1211109GEG0066US0

## (2) Rear Wheels

Rear tread width can be adjusted as shown with the standard equipped tires.

To change the tread width

1. Remove the wheel rim and / or disk mounting bolts.
2. Change the position of the rim and / or disk (right and left) to the desired position, and tighten the bolts.

### ■ IMPORTANT

- Always attach wheels as shown in the drawing.
- If not attached as illustrated, transmission parts may be damaged.
- When re-fitting or adjusting a wheel, tighten the bolts to the following torques then recheck after driving the tractor 200 m (219 yards) and 10 times of shuttle movement by 5 m (5 yards), and thereafter according to service interval.
- To attach 13.6-16 rear tires, need to use rear tire spacer.

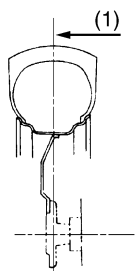
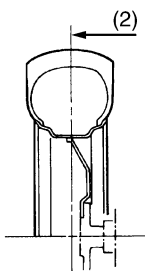
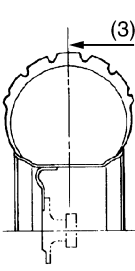
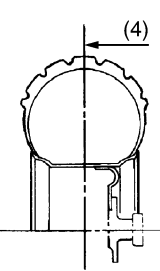
Tires	9.5-22 Farm		13.6-16 Turf	
Tread	 <p>3TGAAAB0P037A</p>		 <p>3TGAAAB0P039B</p>	

(1) 950 mm (37.40 in.)

(2) 1070 mm (42.13 in.)

(3) 990 mm (39.0 in.)

(4) 1055 mm (41.54 in.)

9Y1211109GEG0067US0

### [3] TIRE LIQUID INJECTION

Auxiliary weights can be used to increase traction force for plowing in fields or clayey ground.

Another way is to inject water or another liquid, such as a calcium chloride solution in the tires. Water must not be used in winter since it freezes at 0 °C (32 °F). The calcium chloride solution will not freeze and moreover, affords higher effect than water since its specific gravity is higher than that of water by about 20 %. Below is an explanation of calcium chloride solution injection.

**■ IMPORTANT**

- Do not fill the front tires with liquid.

9Y1211109GEG0068US0

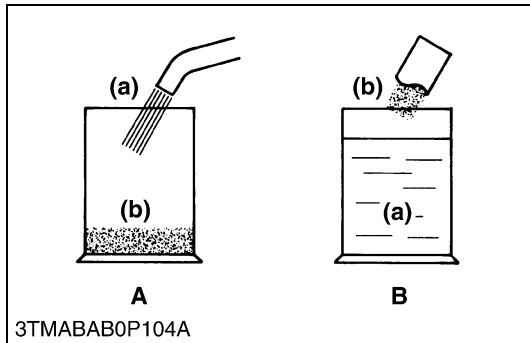

#### Preparation of Calcium Chloride Solution

**⚠ CAUTION**

- When making a calcium chloride solution, do not pour water over calcium chloride since this results in chemical reaction which will cause high temperature. Instead add a small amount of calcium chloride to the water at a time until the desired solution is achieved.

Freezing temperature	Weight of CaCl <sub>2</sub> to be dissolved in 100 L (26.5 U.S.gals, 22.0 Imp.gals) of water
-5 °C (23 °F)	12 kg (26.4 lbs)
-10 °C (14 °F)	21 kg (46.3 lbs)
-15 °C (5 °F)	28 kg (61.7 lbs)
-20 °C (-4 °F)	34 kg (75.0 lbs)
-25 °C (-13 °F)	40 kg (88.2 lbs)
-30 °C (-22 °F)	44 kg (97.0 lbs)
-35 °C (-31 °F)	49 kg (108 lbs)
-40 °C (-40 °F)	52 kg (114.6 lbs)
-45 °C (-49 °F)	56 kg (123.5 lbs)
-50 °C (-58 °F)	61 kg (134.5 lbs)

- (a) Water
- (b) CaCl<sub>2</sub> (Calcium Chloride)
- A: Bad
- B: Good

9Y1211109GEG0069US0

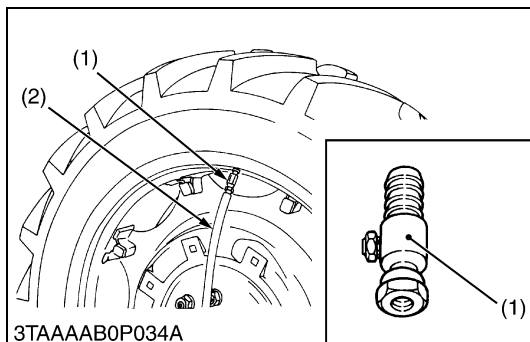

#### Attaching Injector

1. Lift the rear tires off the ground.
2. Turn the tire so that the air valve is at the top.
3. Remove the air valve, and attach the injector. (Code No. 07916-52501)

- (1) Injector
- (2) Hose

9Y1211109GEG0070US0



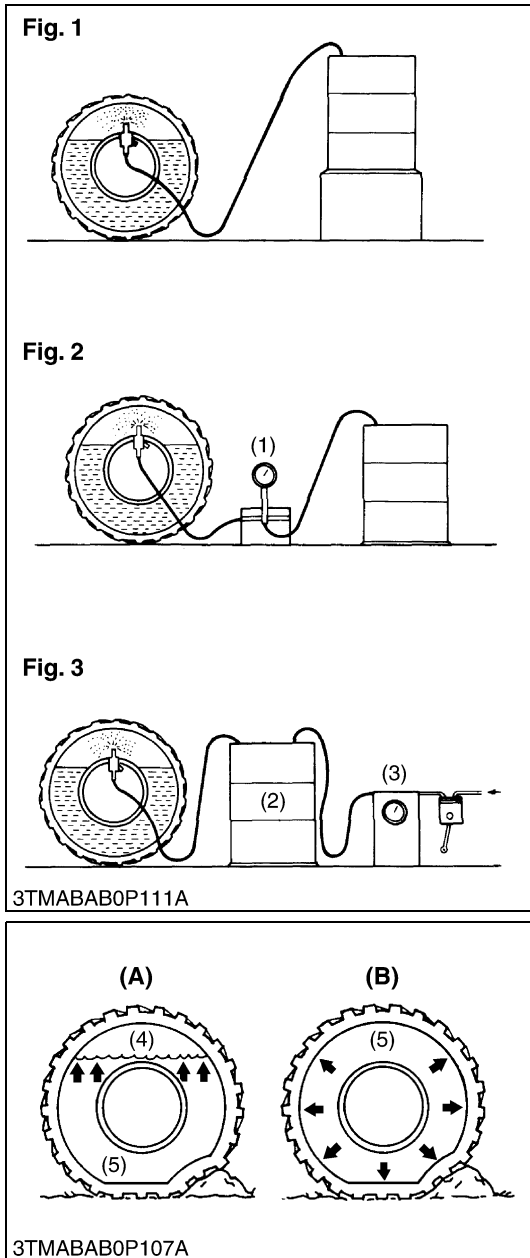

**Injection**

**CAUTION**

- When a calcium chloride solution is used, cool it before pouring it into the tire.
- Do not fill tires with water or solution more than 75 % of full capacity (to the valve stem level).

The following four ways can be used to inject water or a calcium chloride solution into tires.

1. Gravity injection (Fig. 1)
2. Pump injection (Fig. 2)
3. Pressure tank injection (Fig. 3)
4. Injection directly from top (only when water is being used).

**NOTE**

- Once injection is completed, reset the air valve, and pump air into the tire to the specified pressure.

Weight of Calcium Chloride Solution Filling 75 % of Full Capacity of a Tire

Tire sizes	9.5-22
Slush free at -10 °C (14 °F) Solid at -30 °C (-22 °F) [Approx. 1 kg (2 lbs) CaCl <sub>2</sub> per 4 L (1 gal) of water]	68 kg (150 lbs)
Slush free at -24 °C (-11 °F) Solid at -47 °C (-52 °F) [Approx. 1.5 kg (3.5 lbs) CaCl <sub>2</sub> per 4 L (1 gal) of water]	72 kg (159 lbs)
Slush free at -47 °C (-52 °F) Solid at -52 °C (-62 °F) [Approx. 2.25 kg (5 lbs) CaCl <sub>2</sub> per 4 L (1 gal) of water]	76 kg (168 lbs)

- (1) Pump
- (2) Pressure Tank
- (3) Compressor
- (4) Air
- (5) Water

- (A) Correct: 75 % Air Compresses Like a Cushion**
- (B) Incorrect: 100 % Water can not be Compressed**

9Y1211109GEG0071US0

# 1 ENGINE

# MECHANISM

## CONTENTS

1. LUBRICATING SYSTEM.....	1-M1
2. COOLING SYSTEM .....	1-M2
3. FUEL SYSTEM.....	1-M3

# 1. LUBRICATING SYSTEM

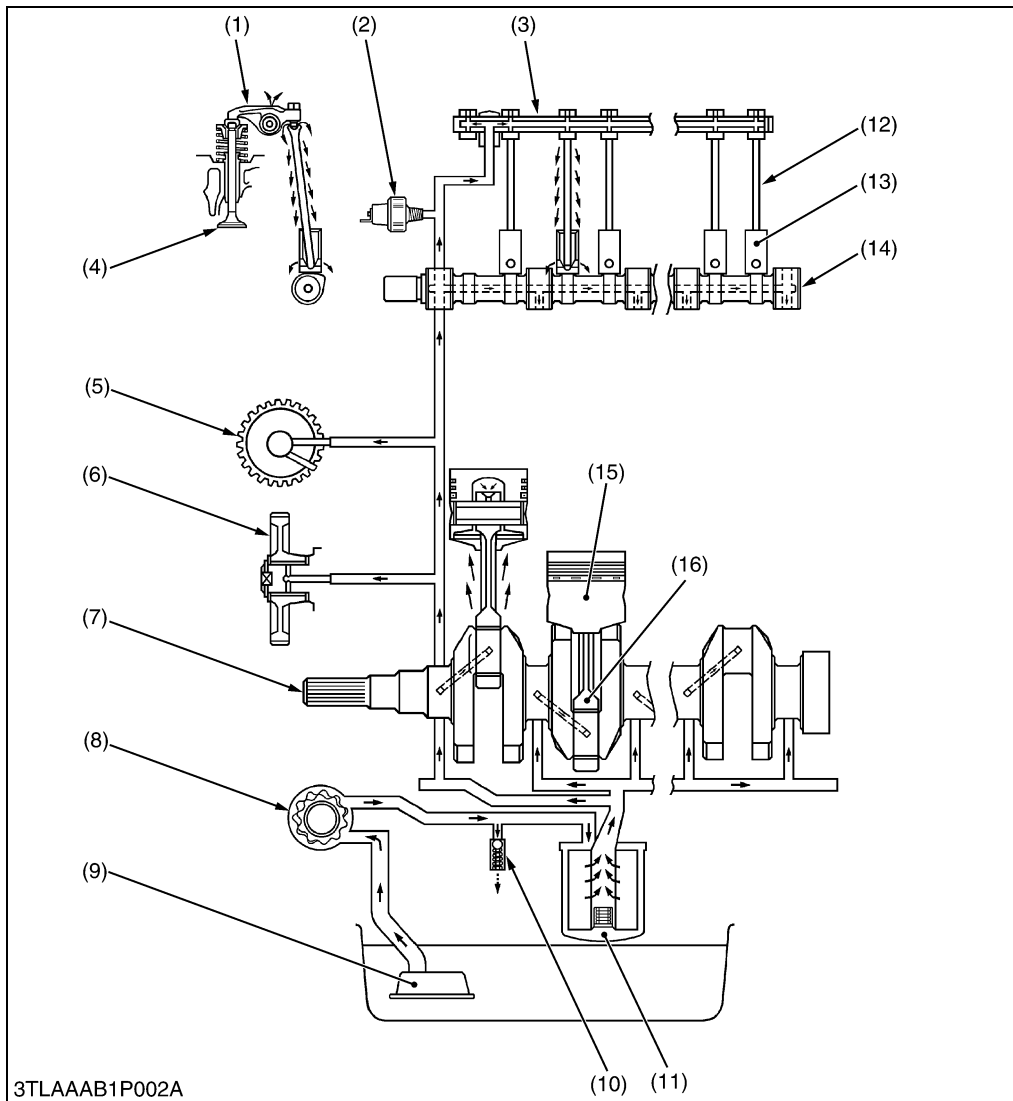

- (1) Rocker Arm
- (2) Oil Pressure Switch
- (3) Rocker Arm Shaft
- (4) Valve
- (5) Governor Shaft
- (6) Idle Gear
- (7) Crankshaft
- (8) Oil Pump
- (9) Oil Strainer
- (10) Relief Valve
- (11) Oil Filter Cartridge
- (12) Push Rod
- (13) Tappet
- (14) Camshaft
- (15) Piston
- (16) Connecting Rod

3TLAAAB1P002A

A lubricating system consists of an oil strainer (9), oil pump (8), relief valve (10), oil filter cartridge (11) and oil pressure switch (2).

The oil pump sucks lubricating oil from the oil pan through the oil strainer and the oil flows down to the oil filter cartridge where it is further filtered. Then the oil is forced to crankshaft (7), connecting rods (16), idle gear (6), governor shaft (5), camshaft (14) and rocker arm shaft (3) to lubricate each part through the oil gallery.

9Y1211109ENM0001US0

## 2. COOLING SYSTEM

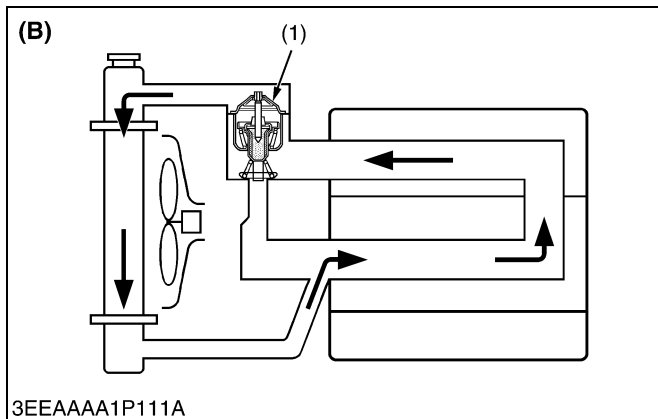
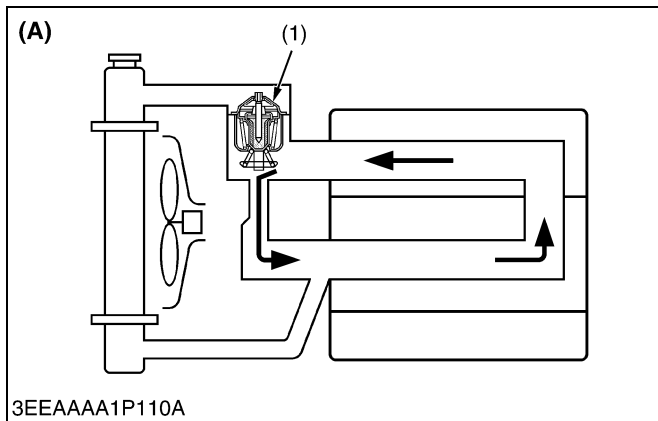

Bottom bypass system is introduced in 03-M Series for improving the cooling performance of the radiator.

While the temperature of coolant in the engine is low, the thermostat is held closed and the coolant is allowed to flow through the bypass pipe and to circulate in the engine.

When the temperature exceeds the thermostat valve opening level, the thermostat fully opens itself to prevent the hot coolant from flowing through the bypass into the engine.

In this way, the radiator can increase its cooling performance.

(1) Thermostat

(A) Thermostat Closed

(B) Thermostat Open

9Y1211109ENM0002US0

### 3. FUEL SYSTEM

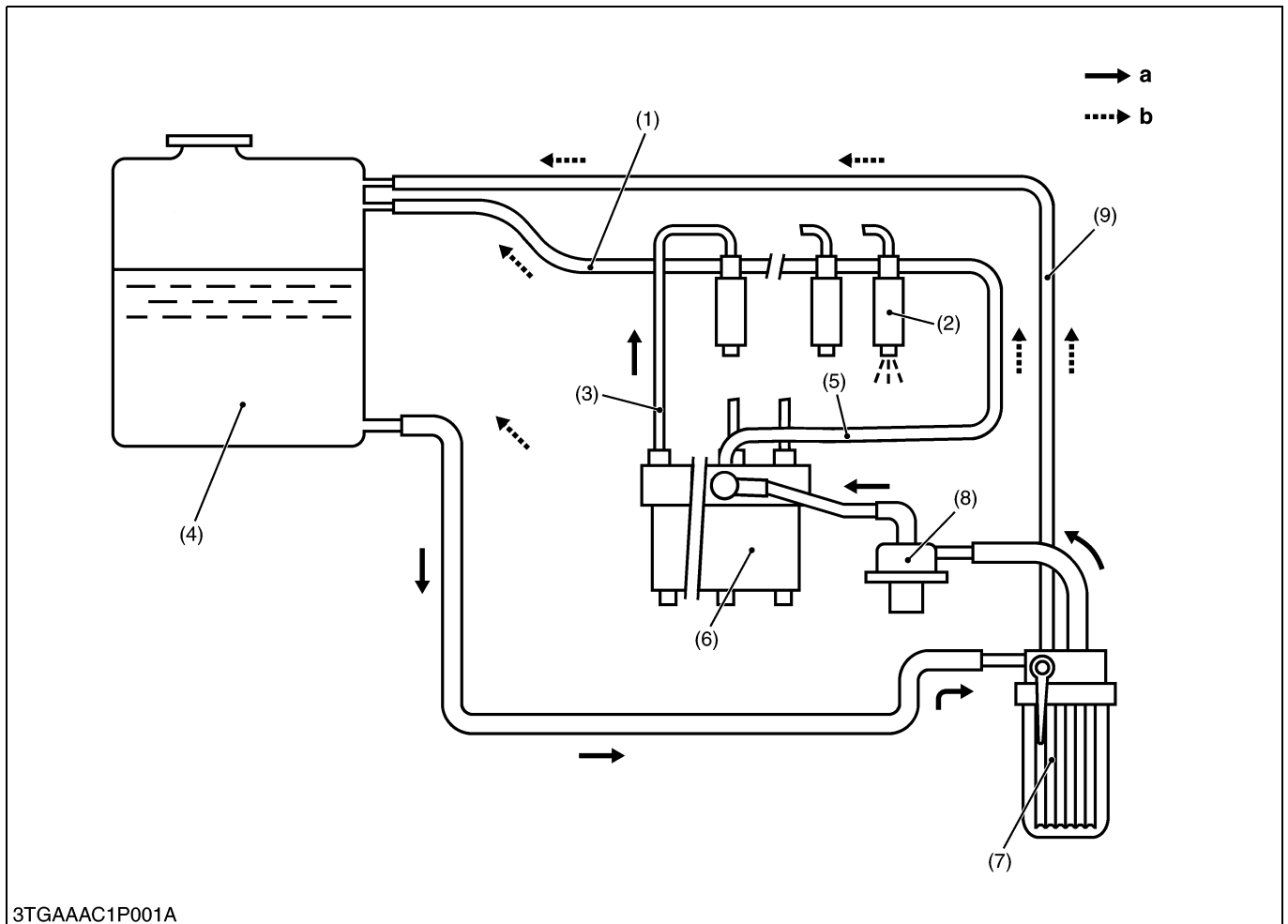

(1) Fuel Overflow Pipe  
(2) Injection Nozzle  
(3) Injection Pipe

(4) Fuel Tank  
(5) Injection Pump Air Vent Pipe  
(6) Injection Pump

(7) Fuel Filter  
(8) Fuel Feed Pump  
(9) Fuel Filter Air Vent Pipe

**a: Injected Fuel Flow**  
**b: Returned Fuel Flow**

The fuel system of this tractor is shown in the diagram above.

Fuel from the tank flows in the passage as shown by the arrows, and is injected from the nozzle via the fuel injection pump. Overflow fuel returns to the tank.

The system includes filters and other concerns to protect it from entrance of air, water and dust.

While the engine is operating, fuel is fed into the injection pump (6) by the fuel feed pump (8) after passing through the fuel filter (7). The fuel camshaft actuates the injection pump and force-feeds fuel to the injection nozzle (2) through the injection pipe (3). Fuel is then sprayed through the nozzle into the combustion chamber. The fuel discharged after lubricating and cooling the injection nozzle is returned to the fuel tank (4) automatically through the overflow pipe (1).

9Y1211109ENM0003US0

# SERVICING

## CONTENTS

1. TROUBLESHOOTING.....	1-S1
2. SERVICING SPECIFICATIONS.....	1-S5
3. TIGHTENING TORQUES.....	1-S10
4. CHECKING, DISASSEMBLING AND SERVICING.....	1-S12
[1] CHECKING AND ADJUSTING.....	1-S12
(1) Engine Body.....	1-S12
(2) Lubricating System.....	1-S15
(3) Cooling System.....	1-S15
(4) Fuel System.....	1-S18
[2] PREPARATION.....	1-S20
(1) Separating Engine from Tractor for ROPS.....	1-S20
(2) Separating Engine from Tractor for CABIN.....	1-S30
[3] DISASSEMBLING AND ASSEMBLING.....	1-S47
(1) Cylinder Head and Valves.....	1-S47
(2) Timing Gears, Camshaft and Fuel Camshaft.....	1-S51
(3) Piston and Connecting Rod.....	1-S56
(4) Crankshaft.....	1-S59
(5) Thermostat and Water Pump.....	1-S62
[4] SERVICING.....	1-S63
(1) Cylinder Head and Valves.....	1-S63
(2) Timing Gears, Camshaft and Fuel Camshaft.....	1-S68
(3) Piston and Connecting Rod.....	1-S71
(4) Crankshaft.....	1-S73
(5) Cylinder.....	1-S77
(6) Oil Pump.....	1-S78

# 1. TROUBLESHOOTING

Symptom	Probable Cause and Checking Procedure	Solution	Reference Page
<b>Stator Motor Does not Operate</b>	1. Battery is discharged.	Recharge battery.	G-29
	2. Battery is damaged.	Replace battery.	–
	3. Slow blow fuse is blown.	Replace slow blow fuse.	G-38
	4. PTO control switch is engaged.	Disengage PTO control switch.	–
	5. Safety switch (clutch pedal and HST) is damaged.	Replace or adjust safety switch.	9-S26
	6. Seat switch is damaged.	Replace seat	9-S26
	7. Rear PTO switch is damaged.	Replace or adjust rear PTO switch	9-S39
	8. Mid PTO switch is damaged.	Replace or adjust mid PTO switch	9-S39
	9. OPC controller is damaged.	Replace OPC controller	9-S30
	10. Main switch is damaged.	Replace main switch	9-S12, 9-S14
	11. Starter motor is damaged.	Replace or repair starter motor.	9-S25



Symptom	Probable Cause and Checking Procedure	Solution	Reference Page
<b>Engine Does Not Start</b>	1. Fuel tank is empty.	Fill fuel to fuel tank.	G-8
	2. Fuel filter is clogged.	Replace fuel filter.	G-25
	3. Air is in the fuel system.	Bleed air.	G-37
	4. Fuel pipe or fuel hose is clogged.	Clean or replace fuel pipe or fuel hose.	G-26
	5. Water is in the fuel system.	Change fuel and repair or replace fuel system.	G-8, G-25
	6. Injection nozzle is stuck or clogged.	Replace or repair injection nozzle	1-S19
	7. Fuel is leaking due to loose injection pipe retaining nut.	Tighten retaining nut.	1-S47
	8. Fuel with low cetane number is used.	Use specified fuel	G-8
	9. Excessively high viscosity of fuel or engine oil is used at low temperature.	Use specified fuel or engine oil.	G-8
	10. Injection pump is damaged.	Replace or repair injection pump.	1-S51
	11. Compression is leaking from cylinder.	Replace head gasket, tighten cylinder head bolt, glow plug and nozzle holder.	1-S49, 1-S58, 1-S64, 1-S72, 1-S77
	12. Piston ring and cylinder is worn out.	Replace piston ring and cylinder.	1-S72
	13. Fuel cam shaft is worn out.	Replace fuel camshaft.	1-S55
	14. Crankshaft, camshaft, piston or bearing is seized.	Repair or replace crankshaft, camshaft, piston or bearing.	1-S55, 1-S57, 1-S60, 1-S61
	15. Valve timing is improper.	Correct valve timing	1-S14
	16. Incorrect injection timing.	Adjust injection timing	1-S18

Symptom	Probable Cause and Checking Procedure	Solution	Reference Page
<b>Engine Revolution Is Not Smooth</b>	1. Fuel filter is clogged or dirty.	Replace fuel filter.	G-25
	2. Air cleaner element is clogged.	Clean or replace air cleaner element.	G-24
	3. Fuel leak due to loose injection pipe retaining nut.	Tighten retaining nut.	1-S47
	4. Injection nozzle is stuck or clogged.	Replace or repair injection nozzle.	1-S19
	5. Crankshaft, camshaft, piston or bearing is seized.	Repair or replace crankshaft, camshaft, piston or bearing.	1-S55, 1-S57, 1-S60, 1-S61
	6. Compression is leaking from cylinder.	Replace head gasket, tighten cylinder head bolt, glow plug and nozzle holder.	1-S49, 1-S58, 1-S64, 1-S72, 1-S77
	7. Valve timing is improper.	Correct valve timing.	1-S14
	8. Piston and cylinder is worn out.	Replace piston and cylinder.	1-S72
	9. Valve clearance is incorrect.	Adjust valve clearance.	1-S14
<b>Either White or Blue Exhaust Gas Is Observed</b>	1. Engine oil is excessive.	Reduce is to specified level engine oil.	G-8
	2. Piston ring and cylinder is worn or stuck.	Replace piston ring and cylinder.	1-S72
<b>Either Black or Dark Gray Exhaust Gas Is Observed</b>	1. Tractor is operated under overload condition.	Reduce the load.	–
	2. Low grade fuel is used.	Use specified fuel.	G-8
	3. Fuel filter is clogged.	Replace fuel filter.	G-25
	4. Air cleaner element is clogged.	Clean or replace air cleaner element.	G-24
	5. Injection nozzle is stuck or clogged.	Replace or repair injection nozzle.	1-S19
<b>Tractor Operator Feels Deficient Engine Output</b>	1. Engine's moving parts is stuck.	Repair or replace engine's moving parts.	–
	2. Injection pump is damaged.	Replace injection pump.	1-S51
	3. Injection nozzle stuck or clogged.	Replace or replace injection nozzle.	1-S19
	4. Compression is leaking.	Check the compression pressure and repair piston ring or cylinder (engine crankcase).	1-S12, 1-S72
	5. Air cleaner element is dirty or clogged.	Clean or replace air cleaner element.	G-24

Symptom	Probable Cause and Checking Procedure	Solution	Reference Page
<b>Lubricant Oil Consumption Is Excessive</b>	1. Piston ring's gap faces the same direction.	Shift ring gap direction.	1-S57
	2. Oil ring is worn or stuck.	Replace oil ring.	1-S58
	3. Piston ring groove is worn out.	Replace piston and piston ring.	1-S57, 1-S58
	4. Valve stem and valve guide is worn out.	Replace valve stem and valve guide.	1-S50
	5. Crankshaft bearing and crank pin bearing is worn out.	Replace crankshaft bearing and crank pin bearing.	1-S61
<b>Fuel Is Mixed into Lubricant Oil</b>	1. Injection nozzle stuck or clogged.	Replace or replace injection nozzle.	1-S48
	2. Engine oil is diluted due to regeneration.	Change engine oil.	1-S20, 1-S31
<b>Water Is Mixed into Lubricant Oil</b>	1. Head gasket is damaged.	Replace head gasket.	1-S49
	2. Cylinder (crankcase) or cylinder head is flawed.	Replace cylinder (crankcase) or cylinder head.	1-S49
<b>Oil Pressure Is Low</b>	1. Engine oil is insufficient.	Fill engine oil.	G-8
	2. Oil strainer is clogged.	Clean oil strainer.	1-S56
	3. Relief valve is stuck with dirt.	Clean relief valve.	–
	4. Oil clearance of moving parts is excessive.	Replace moving parts.	1-S74, 1-S75, 1-S76
	5. Oil passage is clogged.	Clean oil passage.	–
	6. Different type of oil is used.	Use specified type of oil.	G-8
	7. Oil pump is damaged.	Replace oil pump.	1-S55
<b>Oil Pressure Is High</b>	1. Different type of oil is used.	Use specified type of oil.	G-8
	2. Relief valve is damaged.	Repair or replace relief valve.	–
<b>Engine Is Overheated</b>	1. Engine oil is insufficient.	Fill engine oil to proper level.	G-16
	2. Fan belt is broken or elongated.	Change or adjust fan belt.	G-26
	3. Coolant is insufficient.	Fill coolant.	G-35
	4. Radiator net and radiator fin is clogged with dust.	Clean radiator net and radiator fin.	–
	5. Inside of radiator is corroded.	Clean inside of radiator or replace radiator.	G-35
	6. Coolant flow route is corroded.	Clean coolant flow route.	G-35
	7. Radiator or radiator cap is damaged.	Replace radiator or radiator cap.	1-S16
	8. Engine is running under overload condition.	Reduce the load.	–
	9. Cylinder head gasket is damaged.	Replace cylinder head gasket.	1-S49
	10. Unsuitable fuel is used.	Use specified fuel.	G-8

## 2. SERVICING SPECIFICATIONS

### ENGINE BODY

Item		Factory Specification	Allowable Limit
Valve Clearance (When Cold)		0.18 to 0.22 mm 0.0071 to 0.0086 in.	–
Compression Pressure (When Cranking with Starting Motor)		3.6 to 4.0 MPa / 290 min <sup>-1</sup> (rpm) 36 to 41 kgf/cm <sup>2</sup> / 290 min <sup>-1</sup> (rpm) 520 to 580 psi / 290 min <sup>-1</sup> (rpm)	2.5 MPa / 290 min <sup>-1</sup> (rpm) 26 kgf/cm <sup>2</sup> / 290 min <sup>-1</sup> (rpm) 370 psi / 290 min <sup>-1</sup> (rpm)
Difference among Cylinders		–	10 % or less
Top Clearance		0.55 to 0.70 mm 0.022 to 0.027 in.	–
Cylinder Head Surface	Flatness	–	0.05 mm / 500 mm 0.002 in. / 19.7 in.
Valve Recessing	Protrusion	0.05 mm 0.002 in.	–
	Recessing	0.15 mm 0.0059 in.	0.40 mm 0.016 in.
Valve Stem to Valve Guide	Clearance	0.040 to 0.070 mm 0.0016 to 0.0027 in.	0.10 mm 0.0039 in.
	• Valve Stem O.D.	7.960 to 7.975 mm 0.3134 to 0.3139 in.	–
	• Valve Guide I.D.	8.015 to 8.030 mm 0.3156 to 0.3161 in.	–
Valve Face	Angle (Intake)	1.0 rad 60 °	–
	Angle (Exhaust)	0.79 rad 45 °	–
Valve Seat	Width (Intake)	2.12 mm 0.0835 in.	–
	Width (Exhaust)	2.12 mm 0.0835 in.	–
Valve Seat	Angle (Intake)	1.0 rad 60 °	–
	Angle (Exhaust)	0.79 rad 45 °	–
Valve Timing (Intake Valve)	Open	0.21 rad (12 °) before T.D.C.	–
	Close	0.63 rad (36 °) after B.D.C.	–
Valve Timing (Exhaust Valve)	Open	1.0 rad (60 °) before B.D.C.	–
	Close	0.21 rad (12 °) after T.D.C.	–

Item		Factory Specification	Allowable Limit
Valve Spring	Free Length	41.7 to 42.2 mm 1.65 to 1.66 in.	41.2 mm 1.62 in.
	Setting Load / Setting Length	118 N / 35.0 mm 12.0 kgf / 35.0 mm 26.5 lbs / 1.38 in.	100 N / 35.0 mm 10.2 kgf / 35.0 mm 22.5 lbs / 1.38 in.
	Tilt	–	1.0 mm 0.039 in.
Rocker Arm Shaft to Rocker Arm	Oil Clearance	0.016 to 0.045 mm 0.00063 to 0.0017 in.	0.10 mm 0.0039 in.
	• Rocker Arm Shaft O.D.	13.973 to 13.984 mm 0.55012 to 0.55055 in.	–
	• Rocker Arm I.D.	14.000 to 14.018 mm 0.55119 to 0.55188 in.	–
Push Rod	Alignment	–	0.25 mm 0.0098 in.
Tappet to Tappet Guide	Oil Clearance	0.020 to 0.062 mm 0.00079 to 0.0024 in.	0.07 mm 0.003 in.
	• Tappet O.D.	23.959 to 23.980 mm 0.94327 to 0.94409 in.	–
	• Tappet Guide I.D.	24.000 to 24.021 mm 0.94489 to 0.94570 in.	–
Timing Gear	• Crank Gear to Idle Gear Backlash	0.04150 to 0.1122 mm 0.001634 to 0.004417 in.	0.15 mm 0.0059 in.
	• Idle Gear to Cam Gear Backlash	0.04150 to 0.1154 mm 0.001634 to 0.004543 in.	0.15 mm 0.0059 in.
	• Idle Gear to Injection Pump Gear Backlash	0.04150 to 0.1154 mm 0.001634 to 0.004543 in.	0.15 mm 0.0059 in.
	• Crank Gear to Oil Pump Gear Backlash	0.04150 to 0.1090 mm 0.001634 to 0.004291 in.	0.15 mm 0.0059 in.
Idle Gear	Side Clearance	0.12 to 0.48 mm 0.0048 to 0.018 in.	0.9 mm 0.0354 in.
Idle Gear Shaft to Idle Gear Bushing	Oil Clearance	0.025 to 0.066 mm 0.00099 to 0.0025 in.	0.10 mm 0.0039 in.
	• Idle Gear Shaft O.D.	37.959 to 37.975 mm 1.4945 to 1.4950 in.	–
	• Idle Gear Bushing I.D.	38.000 to 38.025 mm 1.4961 to 1.4970 in.	–
Camshaft	Side Clearance	0.070 to 0.22 mm 0.0028 to 0.0086 in.	0.30 mm 0.012 in.
	Alignment	–	0.01 mm 0.0004 in.
Cam	Height (Intake / Exhaust)	33.90 mm 1.335 in.	33.85 mm 1.333 in.

Item		Factory Specification	Allowable Limit	
Camshaft Journal to Cylinder Block Bore	Oil Clearance	0.050 to 0.091 mm 0.0020 to 0.0035 in.	0.15 mm 0.0059 in.	
	• Camshaft Journal	O.D.	39.934 to 39.950 mm 1.5722 to 1.5728 in.	–
	• Cylinder Block Bore	I.D.	40.000 to 40.025 mm 1.5748 to 1.5757 in.	–
Piston Pin Bore	I.D.	25.000 to 25.013 mm 0.98426 to 0.98476 in.	25.05 mm 0.9862 in.	
Second Ring to Ring Groove	Clearance	0.0930 to 0.128 mm 0.00367 to 0.00503 in.	0.20 mm 0.0079 in.	
Oil Ring to Ring Groove	Clearance	0.020 to 0.060 mm 0.00079 to 0.0023 in.	0.15 mm 0.0059 in.	
Top Ring	Ring Gap	0.25 to 0.40 mm 0.0099 to 0.015 in.	1.25 mm 0.0492 in.	
Second Ring	Ring Gap	0.30 to 0.45 mm 0.012 to 0.017 in.	1.25 mm 0.0492 in.	
Oil Ring	Ring Gap	0.25 to 0.45 mm 0.0099 to 0.017 in.	1.25 mm 0.0492 in.	
Connecting Rod	Alignment	–	0.05 mm 0.002 in.	
Piston Pin to Small End Bushing	Oil Clearance	0.014 to 0.038 mm 0.00056 to 0.0014 in.	0.15 mm 0.0059 in.	
	• Piston Pin	O.D.	25.002 to 25.011 mm 0.98433 to 0.98468 in.	–
	• Small End Bushing	I.D.	25.025 to 25.040 mm 0.98524 to 0.98582 in.	–
Crankshaft	Alignment	–	0.02 mm 0.0008 in.	
Crankshaft Journal to Crankshaft Bearing 1	Oil Clearance	0.0400 to 0.118 mm 0.00158 to 0.00464 in.	0.20 mm 0.0079 in.	
	• Crankshaft Journal	O.D.	59.921 to 59.940 mm 2.3591 to 2.3598 in.	–
	• Crankshaft Bearing 1	I.D.	59.980 to 60.039 mm 2.3615 to 2.3637 in.	–
Crankshaft Journal to Crankshaft Bearing 2	Oil Clearance	0.0400 to 0.104 mm 0.00158 to 0.00409 in.	0.20 mm 0.0079 in.	
	• Crankshaft Journal	O.D.	59.921 to 59.940 mm 2.3591 to 2.3598 in.	–
	• Crankshaft Bearing 2	I.D.	59.980 to 60.025 mm 2.3615 to 2.3631 in.	–

Item		Factory Specification	Allowable Limit
Crankpin to Crankpin Bearing • Crankpin  • Crankpin Bearing	Oil Clearance	0.025 to 0.087 mm 0.00099 to 0.0034 in.	0.20 mm 0.0079 in.
	O.D.	46.959 to 46.975 mm 1.8488 to 1.8494 in.	–
	I.D.	47.000 to 47.046 mm 1.8504 to 1.8522 in.	–
Crankshaft	Side Clearance	0.15 to 0.31 mm 0.0059 to 0.012 in.	0.5 mm 0.02 in.
Cylinder Bore (Standard)	I.D.	87.000 to 87.022 mm 3.4252 to 3.4260 in.	87.150 mm 3.4311 in.
Cylinder Bore (Oversize)	I.D.	87.250 to 87.272 mm 3.4351 to 3.4359 in.	87.400 mm 3.4409 in.

**LUBRICATING SYSTEM**

Item		Factory Specification	Allowable Limit
Engine Oil Pressure	At Idle Speed	More than 98 kPa 1.0 kgf/cm <sup>2</sup> 14 psi	50 kPa 0.5 kgf/cm <sup>2</sup> 7 psi
	At Rated Speed	300 to 440 kPa 3.0 to 4.5 kgf/cm <sup>2</sup> 43 to 64 psi	250 kPa 2.5 kgf/cm <sup>2</sup> 36 psi
Engine Oil Pressure Switch	Working Pressure	50 kPa 0.5 kgf/cm <sup>2</sup> 7 psi	–
Inner Rotor to Outer Rotor	Clearance	0.030 to 0.14 mm 0.0012 to 0.0055 in.	0.2 mm 0.008 in.
Outer Rotor to Pump Body	Clearance	0.11 to 0.19 mm 0.0044 to 0.0074 in.	0.25 mm 0.0098 in.
Inner Rotor to Cover	Clearance	0.105 to 0.150 mm 0.00414 to 0.00590 in.	0.20 mm 0.0079 in.

**COOLING SYSTEM**

Item		Factory Specification	Allowable Limit
Fan Belt	Tension	10 to 12 mm / (0.40 to 0.047 in.) deflection at 98 N (10 kgf, 22 lbs) of force	–
Thermostat	Valve Opening Temperature (At Beginning)	69.5 to 72.5 °C 157.1 to 162.5 °F	–
	Valve Opening Temperature (Opened Completely)	85 °C 185 °F	–
Radiator	Water Tightness	No leak at specified pressure	–
Radiator Cap	Pressure Falling Time	More than 10 seconds for pressure fall from 90 to 60 kPa from 0.9 to 0.6 kgf/cm <sup>2</sup> from 10 to 9 psi	–

**FUEL SYSTEM**

Item		Factory Specification	Allowable Limit
Injection Pump	Injection Timing	0.30 to 0.33 rad (17 to 19 °) before T.D.C.	–
Pump Element	Fuel Tightness	–	13.7 MPa 140 kgf/cm <sup>2</sup> 1990 psi
Delivery Valve	Fuel Tightness	10 seconds 13.7 → 12.7 MPa 140 → 130 kgf/cm <sup>2</sup> 1990 → 1850 psi	5 seconds 13.7 → 12.7 MPa 140 → 130 kgf/cm <sup>2</sup> 1990 → 1850 psi
Injection Nozzle	Injection Pressure	13.8 to 14.7 MPa 140 to 150 kgf/cm <sup>2</sup> 2000 to 2130 psi	–
Injection Nozzle Valve Seat	Valve Seat Tightness	When the pressure is 12.7 MPa (130 kgf/cm <sup>2</sup> , 1850 psi), the valve seat must be fuel tightness.	–

9Y1211109ENS0002US0



### 3. TIGHTENING TORQUES

Tightening torques of screws, bolts and nuts on the table below are especially specified.  
(For general use screws, bolts and nuts: Refer to See "5. TIGHTENING TORQUES" on page G-10.)

Item	N·m	kgf·m	lbf·ft
Steering wheel mounting nut	48.1 to 55.9	4.9 to 5.7	35.4 to 41.2
Delivery hose R.H. retaining nut	24.5 to 29.4	2.5 to 3.0	18.1 to 21.7
Delivery hose L.H. retaining nut	24.5 to 29.4	2.5 to 3.0	18.1 to 21.7
Delivery hose retaining nut	34.3 to 44.1	3.5 to 4.5	25.3 to 32.5
Delivery hose joint screw	45.1 to 53.0	4.60 to 5.40	33.3 to 39.0
Bi-speed delivery pipe joint screw	30 to 40	3.1 to 4.0	23 to 29
Bi-speed delivery pipe retaining nut	29 to 49	3.0 to 5.0	21.7 to 36.2
Engine mounting screw and nut (M10)	48.1 to 55.9	4.9 to 5.7	35.5 to 41.2
Engine mounting nut (M12)	77.5 to 90.2	7.9 to 9.2	57.2 to 66.5
Front axle frame mounting screw (M12)	78 to 90	7.9 to 9.2	58 to 66
Clutch mounting screw	23.5 to 27.5	2.4 to 2.8	17.4 to 20.2
Muffler mounting screw	32 to 37	3.2 to 3.8	24 to 27
Rear wheel mounting screw and nut	196.1 to 225.6	20.0 to 23.0	145 to 166
Hydraulic hose <b>PB</b> , <b>P</b> and <b>T</b> retaining nut	30 to 40	3.1 to 4.0	23 to 29
Outer roof mounting screw	3.5 to 4.0	0.36 to 0.40	2.6 to 2.9
Cabin mounting bolt and nut	124 to 147	12.6 to 15.0	91.1 to 108

Item	Dimension × Pitch	N·m	kgf·m	lbf·ft
Cylinder head cover screw	M6 × 1.0	6.87 to 11.2	0.700 to 1.15	5.07 to 8.31
*Cylinder head screw	M11 × 1.25	93.2 to 98.0	9.50 to 10.0	68.8 to 72.3
*Main bearing case screw 1	M9 × 1.25	46 to 50	4.7 to 5.2	34 to 37
*Main bearing case screw 2	M10 × 1.25	69 to 73	7.0 to 7.5	51 to 54
*Flywheel screw	M12 × 1.25	98.1 to 107	10.0 to 11.0	72.4 to 79.5
*Connecting rod screw	M8 × 1.0	41 to 45	4.1 to 4.6	30 to 33
*Rocker arm bracket screw	M8 × 1.25	24 to 27	2.4 to 2.8	18 to 20
*Idle gear shaft screw	M8 × 1.25	24 to 27	2.4 to 2.8	18 to 20
Fan drive pulley mounting nut	M30 × 1.5	138 to 156	14.0 to 16.0	102 to 115
*Bearing case cover mounting screw	M8 × 1.25	24 to 27	2.4 to 2.8	18 to 20
Glow plug	M10 × 1.25	20 to 24	2.0 to 2.5	15 to 18
Nozzle holder assembly	M20 × 1.5	49 to 68	5.0 to 7.0	37 to 50
Nozzle holder	–	35 to 39	3.5 to 4.0	26 to 28
Oil pressure switch	R1/8	15 to 19	1.5 to 2.0	11 to 14
Injection pipe retaining nut	M12 × 1.5	25 to 34	2.5 to 3.5	18 to 25
Overflow pipe assembly retaining nut	M12 × 1.5	20 to 24	2.0 to 2.5	15 to 18
Camshaft set screw	M8 × 1.25	24 to 27	2.4 to 2.8	18 to 20
Hi-idling body	M14 × 1.0	45 to 49	4.5 to 5.0	33 to 36

■ **NOTE**

- For "\*" marked screws, bolts and nuts on the table, apply engine oil to their threads and seats before tightening.
- The letter "M" in Size × Pitch means that the screw, bolt or nut dimension stands for metric. The size is the nominal outside diameter in mm of the threads. The pitch is the nominal distance in mm between two threads.

9Y1211109ENS0003US0

# 4. CHECKING, DISASSEMBLING AND SERVICING

## [1] CHECKING AND ADJUSTING

### (1) Engine Body

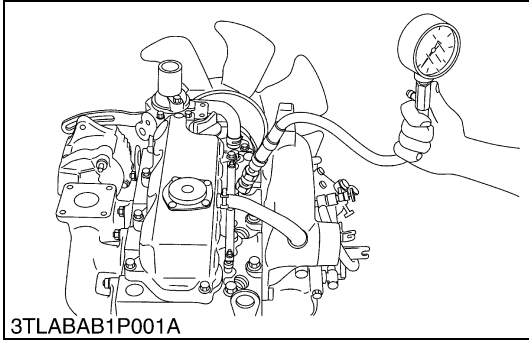

#### Compression Pressure

1. Operate the engine until it is warmed up.
2. Stop the engine and disconnect the **2P** connector from the stop solenoid in order to inject fuel.
3. Remove the air cleaner, the muffler and all injection nozzles.
4. Set a compression tester (Code No. 07909-30208) with the adaptor to the nozzle hole.
5. Keep the engine stop lever at **"Stop Position"**.
6. While cranking the engine with the starter, measure the compression pressure.
7. Repeat steps 4 through 6 for each cylinder.
8. If the measurement is below the allowable limit, apply a small amount of oil to the cylinder wall through the nozzle hole and measure the compression pressure again.
9. If the compression pressure is still less than the allowable limit, check the top clearance, valve and cylinder head.
10. If the compression pressure increases after applying oil, check the cylinder wall and piston rings.

#### ■ NOTE

- Check the compression pressure with the specified valve clearance.
- Always use a fully charged battery for performing this test.
- Variances in cylinder compression values should be under 10 %.

Compression pressure	Factory specification	3.6 to 4.0 MPa 36 to 41 kgf/cm <sup>2</sup> 520 to 580 psi
	Allowable limit	2.5 MPa 26 kgf/cm <sup>2</sup> 370 psi

9Y1211109ENS0004US0

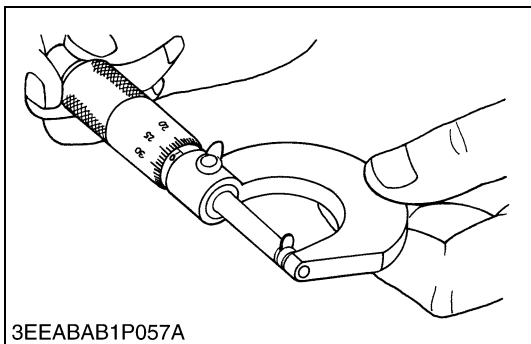
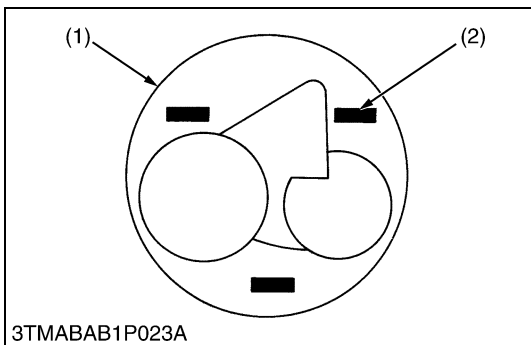

**Top Clearance**

1. Remove the cylinder head.
2. Move the piston and stick a strip of fuse on the piston head at three positions with grease.
3. Lower the piston and install the cylinder head. (Use a new cylinder head gasket and tighten with a specified tightening torque.)
4. Turn the flywheel until the piston passes through the T.D.C..
5. Remove the cylinder head and measure the thickness of the fuses.
6. If the measurement is not within the factory specifications, check the oil clearance between the crankpin and bearing and between the piston pin and bushing.

■ **NOTE**

- **After checking the top clearance, be sure to assemble the cylinder head with a new cylinder head gasket.**

Top clearance	Factory specification	0.55 to 0.70 mm 0.022 to 0.027 in.
Tightening torque	Cylinder head screws	93.2 to 98.0 N·m 9.50 to 10.0 kgf·m 68.8 to 72.3 lbf·ft

(1) Piston

(2) Fuse

9Y1211109ENS0005US0

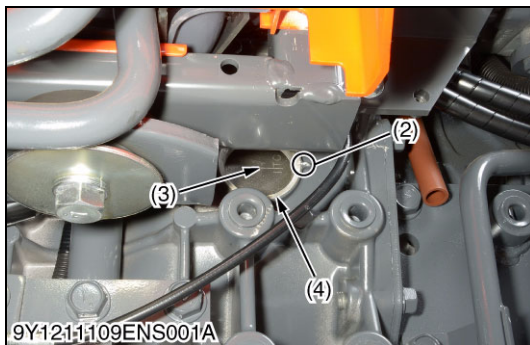
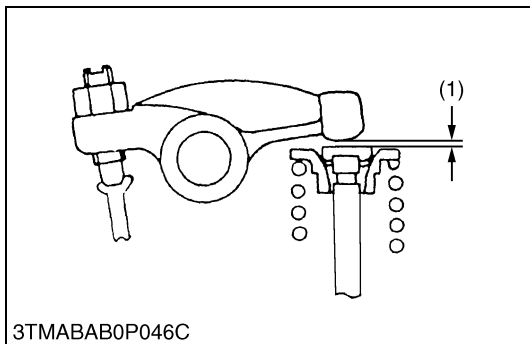
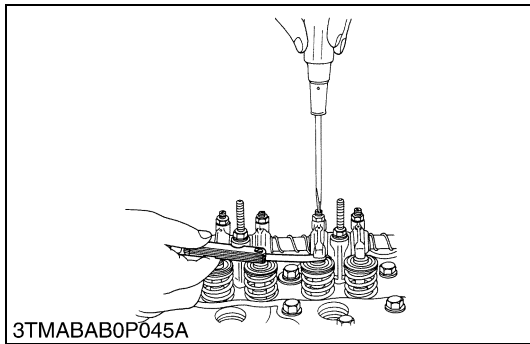

**Valve Clearance**

■ **IMPORTANT**

• The valve clearance must be checked and adjusted when engine is cold.

1. Remove the head cover.
2. Remove the cap of the timing window (4) on the housing under the right step.
3. Align the "TC" mark line (3) on the flywheel and projection (2) on the housing so that the No. 1 piston comes to compression or overlap top dead center.
4. Check the following valve clearance (1) marked with "☆" using a feeler gauge.
5. If the clearance is not within the factory specifications, adjust with the adjusting screw.

■ **NOTE**

- The "TC" marking line on the flywheel is just for No. 1 cylinder. There is no "TC" marking for the other cylinders.
- No. 1 piston comes to the top dead center position when the "TC" marking is aligned with the projection in the window on clutch housing. Turn the flywheel 0.26 rad (15 °) clockwise and counterclockwise to see if the piston is at the compression top dead center or the overlap position. Now referring to the table below, readjust the valve clearance (1). (The piston is at the top dead center when both the IN. and EX. valves do not move. It is at the overlap position when both the valves move.)
- Finally turn the flywheel 6.28 rad (360 °) and align the "TC" marking and the projection (2) perfectly. Adjust all the other valve clearance as required.
- After turning the flywheel counterclockwise twice or three times, recheck the valve clearance (1).
- After adjusting the valve clearance (1), firmly tighten the lock nut of the adjusting screw.

Adjustable cylinder and location of piston		Valve arrangement	
		IN.	EX.
When No. 1 piston is at compression top dead center	No. 1	☆	☆
	No. 2	—	☆
	No. 3	—	—
When No. 1 piston is at overlap position	No. 1	—	—
	No. 2	☆	—
	No. 3	—	☆

- (1) Valve Clearance  
 (2) Projection

- (3) TC Mark Line  
 (4) Timing Window

9Y1211109ENS0006US0

## (2) Lubricating System

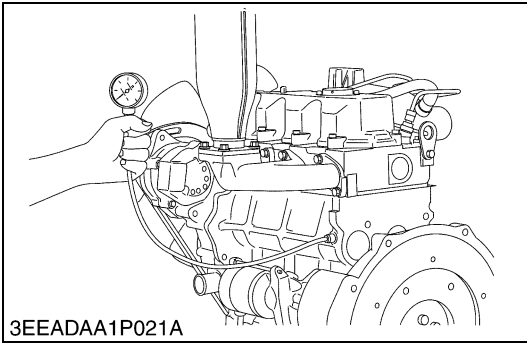

### Engine Oil Pressure

1. Remove the engine oil pressure switch, and set an oil pressure tester (Code No. 07916-32032). (Adaptor screw size: PT 1/8)
2. Start the engine. After warming up, measure the oil pressure of both idling and rated speeds.
3. If the oil pressure is less than the allowable limit, check the following.
  - Engine oil insufficient
  - Oil pump damaged
  - Oil strainer clogged
  - Oil filter cartridge clogged
  - Oil gallery clogged
  - Excessive oil clearance
  - Foreign matter in the relief valve

Engine oil pressure	At idle speed	Factory specification	More than 98 kPa 1.0 kgf/cm <sup>2</sup> 14 psi
		Allowable limit	50 kPa 0.5 kgf/cm <sup>2</sup> 7 psi
	At rated speed	Factory specification	300 to 440 kPa 3.0 to 4.5 kgf/cm <sup>2</sup> 43 to 64 psi
		Allowable limit	250 kPa 2.5 kgf/cm <sup>2</sup> 36 psi

### (When reassembling)

- After checking the engine oil pressure, tighten the engine oil pressure switch to the specified torque.

Tightening torque	Oil pressure switch	15 to 19 N·m 1.5 to 2.0 kgf·m 11 to 14 lbf·ft
-------------------	---------------------	---

9Y1211109ENS0007US0

## (3) Cooling System

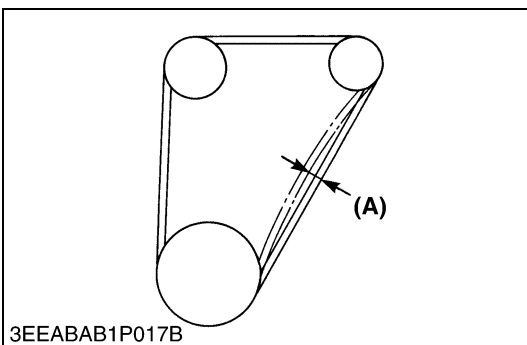

### Fan Belt Tension

1. Measure the deflection **(A)**, depressing the belt halfway between the fan drive pulley and alternator pulley at specified force (98 N, 10 kgf, 22 lbf).
2. If the measurement is not within the factory specifications, loosen the alternator mounting screws and relocate the alternator to adjust.

Deflection <b>(A)</b>	Factory specification	10 to 12 mm 0.40 to 0.47 in.
-----------------------	-----------------------	---------------------------------

### (A) Deflection

9Y1211109ENS0008US0



3EEABAB1P019A

**Fan Belt Damage and Wear**

1. Check the fan belt for damage.
2. If the fan belt is damaged, replace it.
3. Check if the fan belt is worn and sunk in the pulley groove.
4. If the fan belt is nearly worn out and deeply sunk in the pulley groove, replace it.

(A) Good

(B) Bad

9Y1211109ENS0009US0

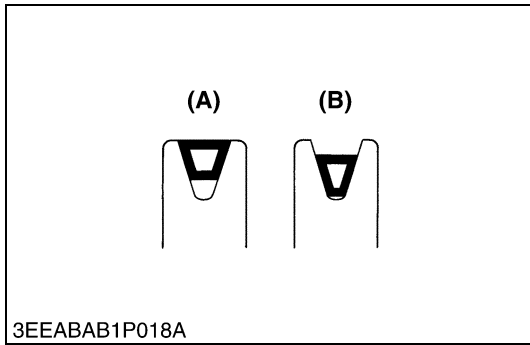

3EEABAB1P018A

**Radiator Cap Air Leakage**

**CAUTION**

- When removing the radiator cap, wait at least ten minutes after the engine has stopped and cooled down. Otherwise, hot water way gush out, scalding nearby people.

1. Set a radiator tester (Code No. 07909-31551) and an adapter (BANZAI Code No. RCT-2A-30S) on the radiator cap.
2. Apply the specified pressure 88 kPa (0.9 kgf/cm<sup>2</sup>, 13 psi), and measure the time for the pressure to fall to 59 kPa (0.6 kgf/cm<sup>2</sup>, 9 psi).
3. If the measurement is less than the factory specification, replace the radiator cap.

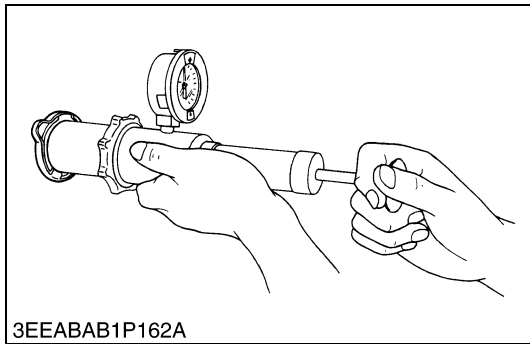

3EEABAB1P162A

Pressure falling time	Factory specification	More than 10 seconds for pressure fall from 90 to 60 kPa (from 0.9 to 0.6 kgf/cm <sup>2</sup> , from 10 to 9 psi)
-----------------------	-----------------------	---

9Y1211109ENS0010US0

**Radiator Water Leakage**

1. Pour a specified amount of water into the radiator.
2. Set a radiator tester (Code No. 07909-31551) with an adaptor (BANZAI Code No. RCT-2A-30S) and raise the water pressure to the specified pressure.
3. Check the radiator for water leaks.
4. For water leak from the pinhole, replace the radiator or repair with the radiator cement. When water leak is excessive, replace the radiator.

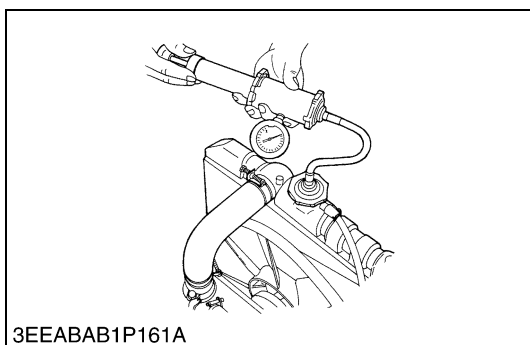

3EEABAB1P161A

Radiator water leakage test pressure	Factory specification	No leaks at 137 kPa 1.4 kgf/cm <sup>2</sup> 20 psi
--------------------------------------	-----------------------	--

9Y1211109ENS0011US0

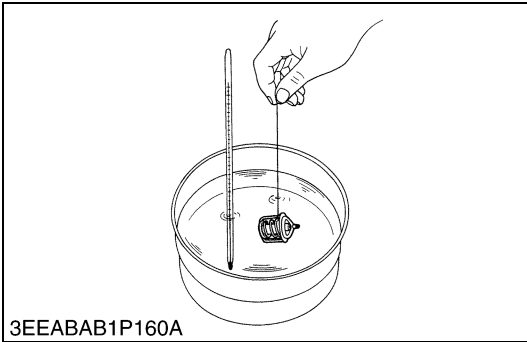

**Thermostat Valve Opening Temperature**

1. Suspend the thermostat in the water by a string with its end inserted between the valve and seat.
2. Heat the water gradually and read the temperature when the valve opens and leaves the string.
3. Continue heating and read the temperature when the valve opens approx. 6 mm (0.236 in.).
4. If the measurement is not within the factory specifications, replace the thermostat.

Thermostat's valve opening temperature	Factory specification	69.5 to 72.5 °C 157.1 to 162.5 °F
Temperature at which thermostat completely opens	Factory specification	85 °C 185 °F

9Y1211109ENS0012US0



### (4) Fuel System

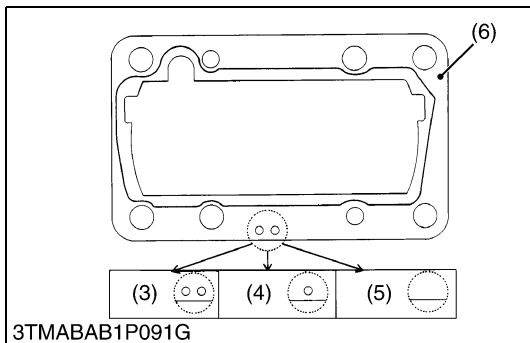
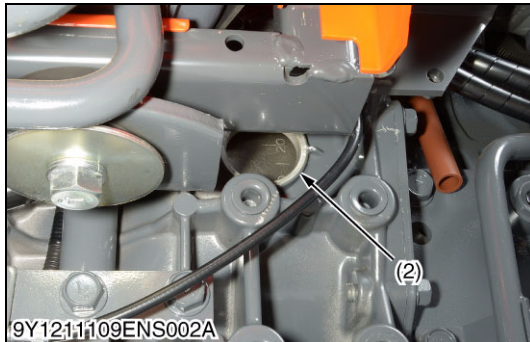
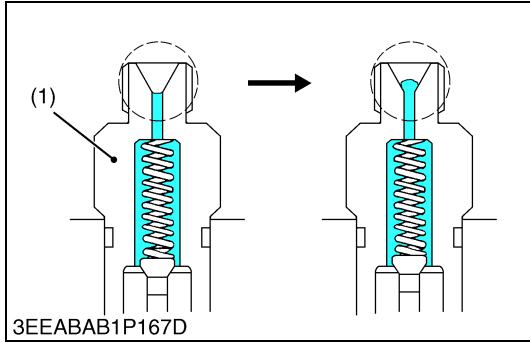
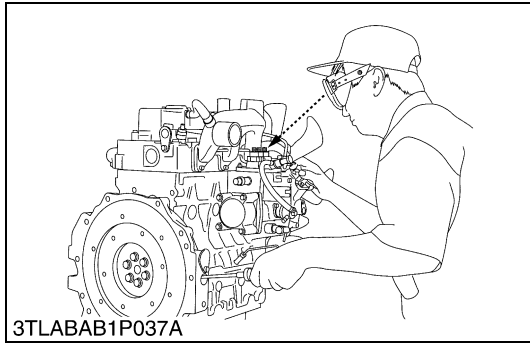

#### Injection Timing

1. Remove the stop solenoid.
2. Remove the injection pipes and nozzle.
3. Remove the cap of the timing window (2) on the housing under the right step.
4. Set the speed control lever to maximum fuel discharge position.
5. Turn the flywheel counterclockwise (facing the flywheel) until the fuel fills up to the hole of the delivery valve holder (1) for 1st cylinder.
6. Turn the flywheel further and stop turning when the fuel begins to flow over, to get the present injection timing.
7. (The flywheel has mark 1TC and four lines indicating every 0.087 rad (5 °) of crank angle from 0.175 rad (10 °) to 0.436 rad (25 °) before mark 1TC) Calculate the angle which the center of the window points out.
8. If the calculation differs from specified injection timing, change, add or remove the shim (6) to adjust.

Injection timing	Factory specification	0.297 to 0.331 rad (17 to 19 °) before T.D.C.
------------------	-----------------------	--

#### NOTE

- The sealant is applied to both sides of the soft metal gasket shim. The liquid gasket is not required for assembling.
- Shims are available in thickness of 0.20 mm (0.0079 in.), 0.25 mm (0.0098 in.) and 0.30 mm (0.0118 in.). Combine these shims for adjustments.
- Injection timing delays or advances by approx. 0.0087 rad (0.5 °), when the thickness of the shim is increased or decreased by 0.05 mm (0.002 in.).
- In disassembling and replacing, be sure to use the same number of new shims with the same thickness.

- |                                     |  |
|-------------------------------------|--|
| (1) Delivery Valve Holder           | (4) One-hole: 0.25 mm (0.0098 in.)     |
| (2) Timing Window                   | (5) Without hole: 0.30 mm (0.0118 in.) |
| (3) Two-holes: 0.20 mm (0.0079 in.) | (6) Soft Metal Gasket Shim             |

9Y1211109ENS0013US0

**CAUTION**

- Check the injection pressure and condition after making sure that there is nobody standing in the direction the fume goes.
- If the fume from the nozzle directly contacts the human body, cells may be destroyed and blood poisoning may be caused.

9Y1211109ENS0014US0

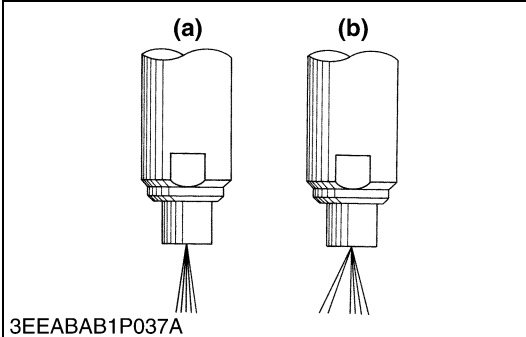

3EEABAB1P037A

**Nozzle Spraying Condition**

1. Set the injection nozzle to a nozzle tester, and check the nozzle spraying condition.
2. If the spraying condition is damaged, replace the nozzle piece.

(a) Good

(b) Bad

9Y1211109ENS0015US0

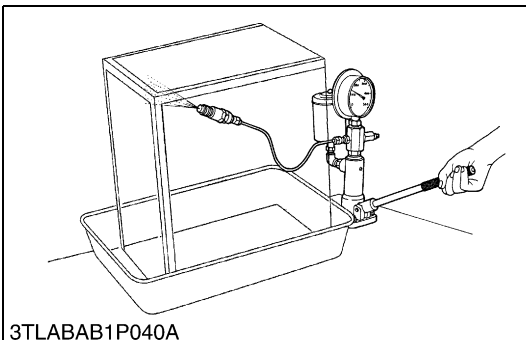

3TLABAB1P040A

**Fuel Injection Pressure**

1. Set the injection nozzle to a nozzle tester.
2. Slowly move the tester handle to measure the pressure at which fuel begins jetting out from the nozzle.
3. If the measurement is not within the factory specifications, replace the adjusting washer (1) in the nozzle holder to adjust it.

Fuel injection pressure	Factory specification	13.8 to 14.7 MPa 140 to 150 kgf/cm <sup>2</sup> 2000 to 2130 psi
-------------------------	-----------------------	--

**(Reference)**

- Pressure variation with 0.01 mm (0.0004 in.) difference of adjusting washer thickness.  
Approx. 235 kPa (2.4 kgf/cm<sup>2</sup>, 34 psi)

(1) Adjusting Washer

9Y1211109ENS0016US0

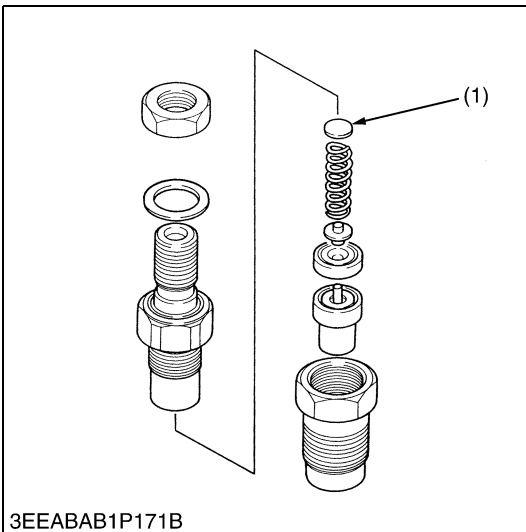

3EEABAB1P171B

**Valve Seat Tightness**

1. Set the injection nozzle to a nozzle tester.
2. Raise the fuel pressure, and keep at 12.75 MPa (130 kgf/cm<sup>2</sup>, 1849 psi) for 10 seconds.
3. If any fuel leak is found, replace the nozzle piece.

Injection pressure	Factory specification	No fuel leak at 12.7 MPa 130 kgf/cm <sup>2</sup> 1850 psi
--------------------	-----------------------	--

9Y1211109ENS0017US0

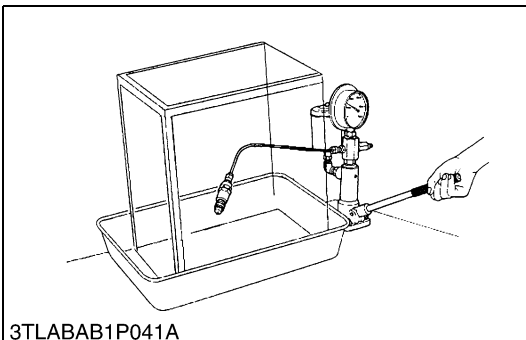

3TLABAB1P041A

## [2] PREPARATION

### (1) Separating Engine from Tractor for ROPS

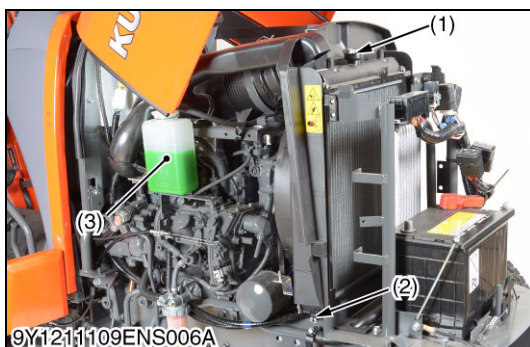
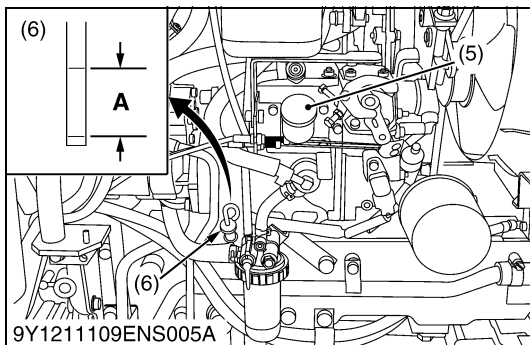
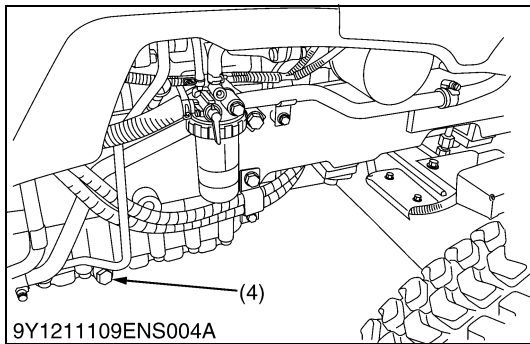
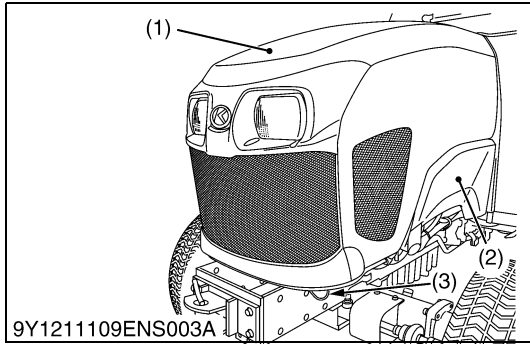

#### Draining Engine Oil

1. Place an oil pan underneath the engine.
2. To open the hood (1), hold the hood (1) and pull the release lever (3) and open the hood (1).
3. Remove the bolt from each of the side covers (2) and remove the side covers (2).
4. To drain the oil, remove the both drain plugs (4) at the bottom of the engine and drain the oil completely into the oil pan.
5. After draining, reinstall the both drain plugs (4).

#### (When reassembling)

- Fill with the new engine oil up to the upper notch on the dipstick (6).

#### ■ IMPORTANT

- When using an oil of different manufacture or viscosity from the previous one, remove all of the old oil.
- Never mix two different types of oil.
- Use the proper SAE Engine Oil according to ambient temperatures.
- Refer to "4. LUBRICANTS, FUEL AND COOLANT" on page G-8.

Engine Oil	Capacity	STW34	5.7 L 6.0 U.S.qts 5.0 Imp.qts
		STW37, STW40	6.7 L 7.1 U.S.qts 5.9 Imp.qts

- |                   |  |
|-------------------|--|
| (1) Hood          | (5) Oil Inlet  |
| (2) Side Cover    | (6) Dipstick   |
| (3) Release Lever | <b>A: Oil level is acceptable within this range.</b> |
| (4) Drain Plug    |  |

9Y1211109ENS0018US0

#### Draining Coolant

#### ⚠ WARNING

To avoid personal injury or death:

- Do not remove the radiator cap while coolant is hot. When cool, slowly rotate cap to the first stop and allow sufficient time for excess pressure to escape before removing the cap completely.

1. Stop the engine and let it cool down.
2. To drain the coolant, open the radiator drain plug (2) and remove radiator cap (1). The radiator cap (1) must be removed to completely drain the coolant.
3. After all coolant is drained, reinstall the drain plug (2).

Coolant (with recovery tank)	Capacity	6.6 L 7.0 U.S.qts 5.8 Imp.qts
------------------------------	----------	-------------------------------------

- |                  |                   |
|------------------|-------------------|
| (1) Radiator Cap | (3) Recovery Tank |
| (2) Drain Plug   |                   |

9Y1211109ENS0019US0

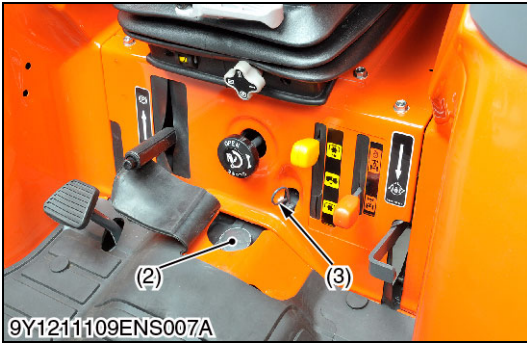
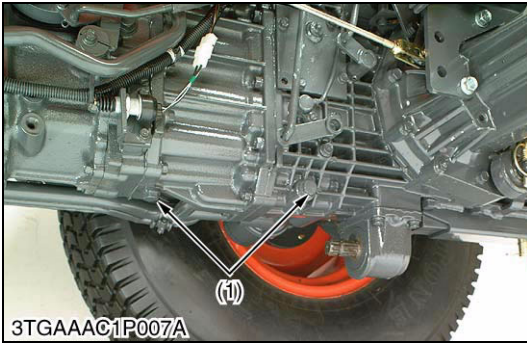

**Draining Transmission Fluid**

1. Place an oil pan underneath the transmission case, and remove the drain plugs (1).
2. Drain the transmission fluid.
3. Reinstall the drain plugs (1).

**(When reassembling)**

- Fill new oil from filling port after removing the filling plug (2) up to the upper notch on the dipstick (3).
- After operating the engine for few minutes, stop it and check the oil level again, if low, add oil prescribed level.

**IMPORTANT**

- **Use only KUBOTA SUPER UDT fluid. Use of other oils may damage the transmission or hydraulic system. Refer to "4. LUBRICANTS, FUEL AND COOLANT" on page G-8**
- **Never work the tractor immediately after changing the transmission oil. Keeping the engine at medium speed for a few minutes to prevents damage to the transmission.**
- **Do not mix different brands oil together.**

Transmission fluid	Capacity	
		24 L
		6.3 U.S.gals
		5.3 Imp.gals

- (1) Drain Plug  
 (2) Filling Plug  
 (3) Dipstick

9Y1211109ENS0020US0

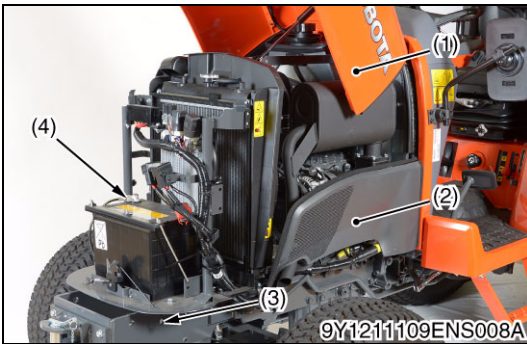

**Hood, Side Cover and Battery Cord**

1. To open the hood (1), hold the hood (1) and pull the release lever (3) and open the hood (1).
2. Remove the bolt from each of the side covers and remove the side covers (2).
3. Disconnect the battery negative cable (4).
4. Disconnect the head light connector (5) and damper (7).
5. Remove the two screws (6), and then remove the hood (1).

**(When reassembling)**

**NOTE**

- **When disconnecting the battery cords, disconnect the grounding cord first. When connecting, positive cord first.**

- (1) Hood  
 (2) Side Cover  
 (3) Release Lever  
 (4) Battery Negative Cable  
 (5) Head Light Connector  
 (6) Screw  
 (7) Damper

9Y1211109ENS0021US0

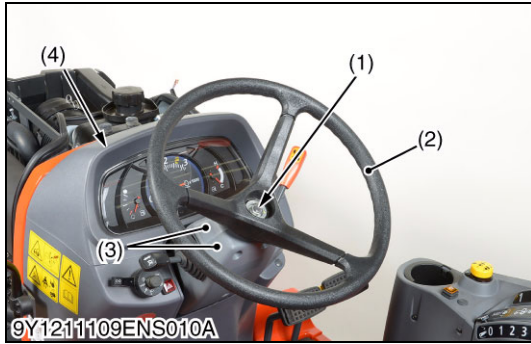

**Steering Wheel and Panel Under Cover**

1. Remove the covers (3).
2. Remove the steering wheel cap.
3. Remove the steering wheel mounting nut (1) and remove the steering wheel (2) with a steering wheel puller (Code No. 07916-51090).
4. Remove the panel cover (4).

**(When reassembling)**

Tightening torque	Steering wheel mounting nut	48.1 to 55.9 N·m 4.9 to 5.7 kgf·m 35.4 to 41.2 lbf·ft
-------------------	-----------------------------	---

- |                    |                 |
|--------------------|-----------------|
| (1) Nut            | (3) Cover       |
| (2) Steering Wheel | (4) Panel Cover |

9Y1211109ENS0022US0

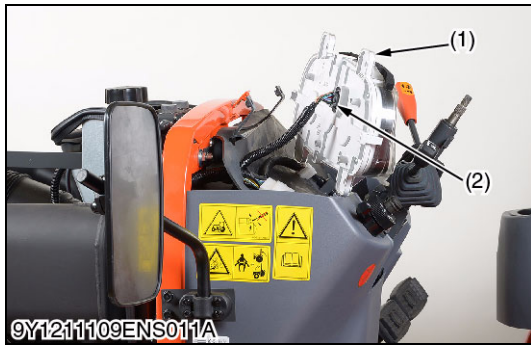

**Instrument Panel**

1. Remove the instrument panel mounting screws and disconnect the instrument panel connector (2). Then remove the instrument panel (1).
2. Disconnect the combination switch connector (6), main switch connector (3) and hazard switch connector (4).
3. Remove the under cover (5).

- |                                |                                  |
|--------------------------------|----------------------------------|
| (1) Instrument Panel           | (4) Hazard Switch Connector      |
| (2) Instrument Panel Connector | (5) Under Cover                  |
| (3) Main Switch Connector      | (6) Combination Switch Connector |

9Y1211109ENS0023US0

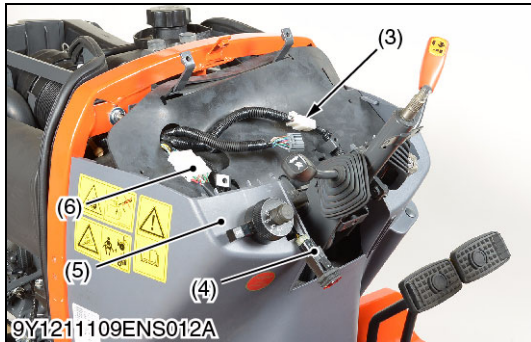

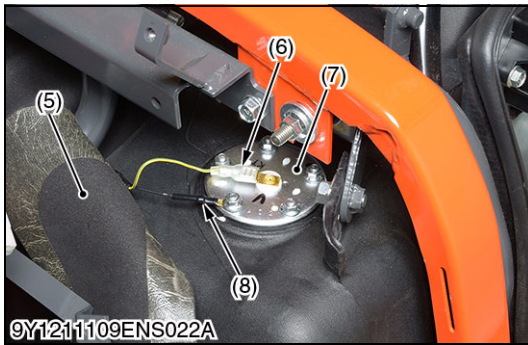
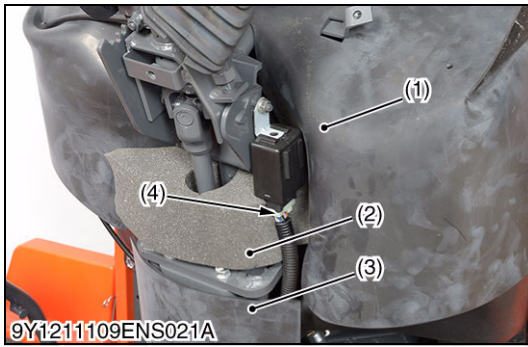
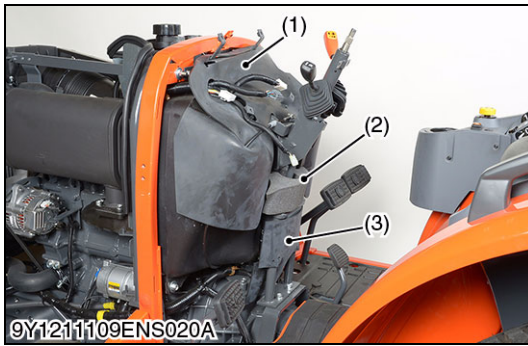

### Rubber and Wiring Harness

1. Remove the fuel tank cover (1)
2. Disconnect the OPC controller connector (4).
3. Remove the steering controller cover (3).
4. Remove the sponge (2).
5. Turn over the fuel sensor cover (5), and disconnect the grounding wire (8) and **1P** connector (6) from the fuel level sensor (7).

- |                               |                         |
|-------------------------------|-------------------------|
| (1) Fuel Tank Cover           | (5) Fuel Sensor Cover   |
| (2) Sponge                    | (6) <b>1P</b> Connector |
| (3) Steering Controller Cover | (7) Fuel Sensor         |
| (4) OPC Controller Connector  | (8) Grounding Wire      |

9Y1211109ENS0024US0

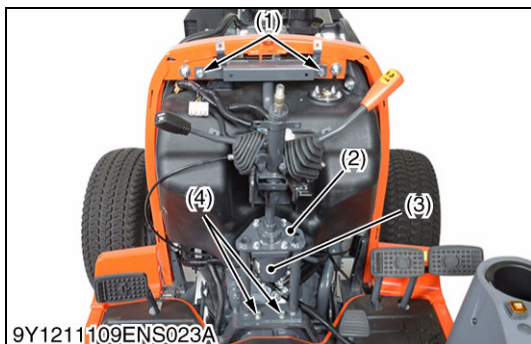
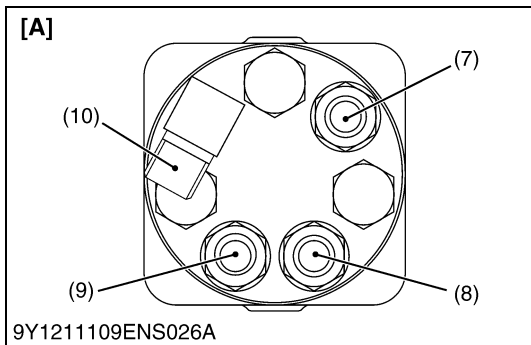
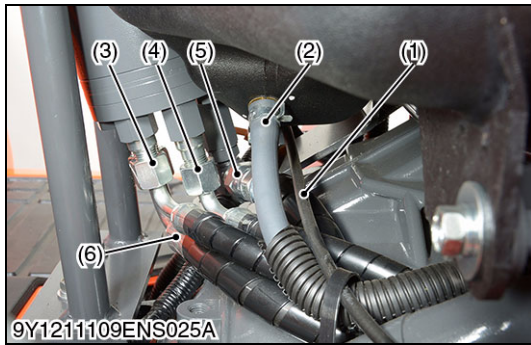
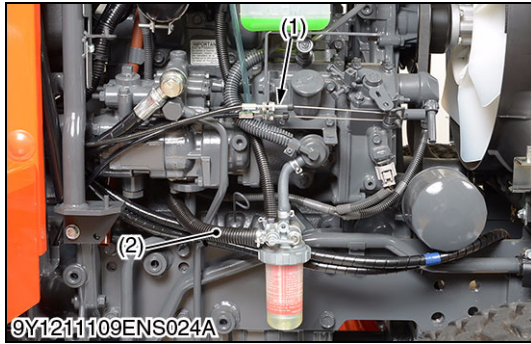

**Power Steering Hoses and Accelerator Wire (Right Side)**

1. Disconnect the accelerator wire (1) from the engine.
2. Disconnect the fuel hose (2).
3. Disconnect the delivery hose L.H. (3) and delivery hose R.H. (4) from the steering controller.
4. Disconnect the power steering delivery hose (6) from the steering controller.
5. Disconnect the power steering return hose (5) from the steering controller.

**(When reassembling)**

- Be sure to connect the each hose to original position.
- Be sure to check the hose joints do not interfere in other joints.

Tightening torque	Delivery hose R.H. (4) retaining nut	24.5 to 29.4 N·m 2.5 to 3.0 kgf·m 18.1 to 21.7 lbf·ft
	Delivery hose L.H. (3) retaining nut	24.5 to 29.4 N·m 2.5 to 3.0 kgf·m 18.1 to 21.7 lbf·ft
	Return hose retaining nut	34.3 to 44.1 N·m 3.5 to 4.5 kgf·m 25.3 to 32.5 lbf·ft
	Delivery hose joint screw	45.1 to 53.0 N·m 4.60 to 5.40 kgf·m 33.3 to 39.0 lbf·ft

- |                                  |             |
|----------------------------------|-------------|
| (1) Accelerator Wire             | (7) P Port  |
| (2) Fuel Hose                    | (8) LT Port |
| (3) Delivery Hose L.H.           | (9) RT Port |
| (4) Delivery Hose R.H.           | (10) T Port |
| (5) Power Steering Return Hose   |             |
| (6) Power Steering Delivery Hose |             |
- [A] Viewed from Bottom Side**

9Y1211109ENS0028US0

**Steering Support**

1. Remove the screws (1).
2. Remove the screws (4).
3. Remove the steering support (2) with steering controller (3).

- |                      |                         |
|----------------------|-------------------------|
| (1) Screw            | (3) Steering Controller |
| (2) Steering Support | (4) Screw               |

9Y1211109ENS0025US0

**Panel Under Frame**

1. Remove the foot covers (1).
2. Remove the screws (2) and nuts (4), and pull up the panel under frame (3).

- |                |                       |
|----------------|-----------------------|
| (1) Foot Cover | (3) Panel Under Frame |
| (2) Screw      | (4) Nut               |

9Y1211109ENS0030US0

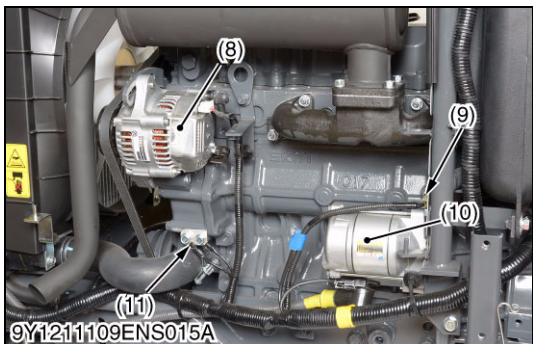
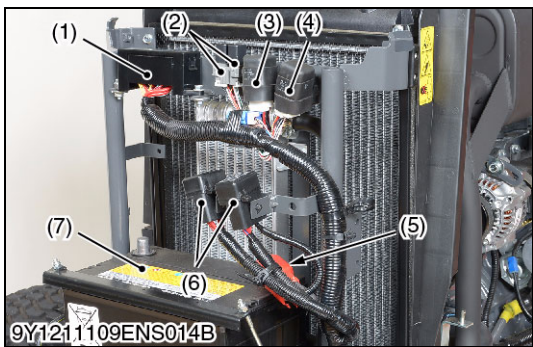

**Wiring Harness (Left Side)**

1. Remove the fuse box (1) from the stay.
2. Disconnect the connectors from the relays (2).
3. Remove the glow relay (3).
4. Remove the key stop relay (4).
5. Remove the slow blow fuse boxes (6).
6. Disconnect the battery positive cable (5) from the battery terminal.
7. Remove the battery (7).
8. Disconnect the connectors from the alternator (8), oil switch (9) and stater (10).
9. Disconnect the grounding terminal (11).

- |                            |                         |
|----------------------------|-------------------------|
| (1) Fuse Box               | (6) Slow Blow Fuse      |
| (2) Relay                  | (7) Battery             |
| (3) Glow Relay             | (8) Alternator          |
| (4) Key Stop Relay         | (9) Oil Switch          |
| (5) Battery Positive Cable | (10) Starter            |
|                            | (11) Grounding Terminal |

9Y1211109ENS0026US0



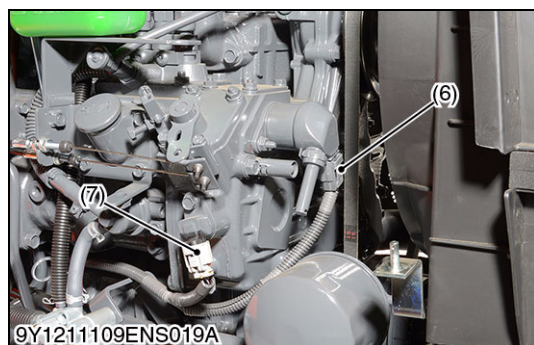
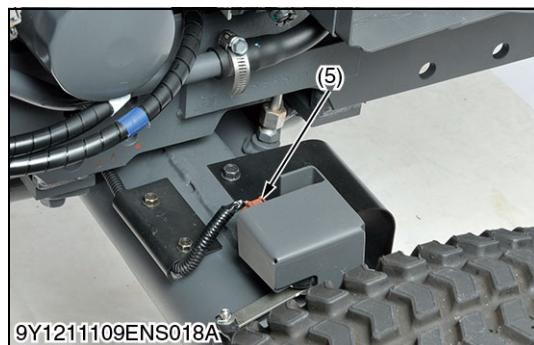
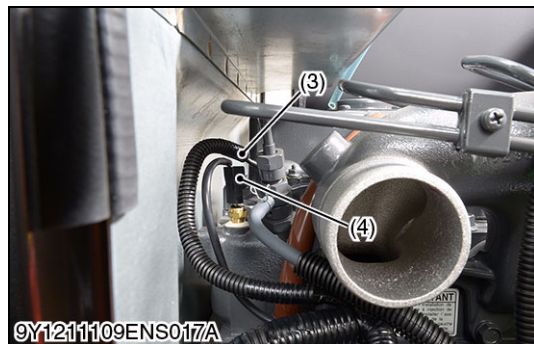
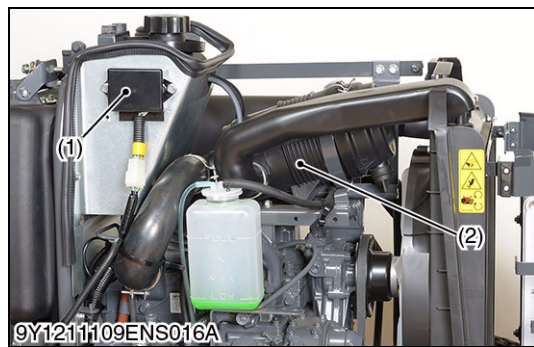

### Wiring Harness (Right Side)

1. Disconnect the connector from the flasher unit (1).
2. Remove the air cleaner (2).
3. Disconnect the glow plug cable (3).
4. Disconnect the **1P** connector (4) from the coolant temperature sensor.
5. Disconnect the connector from the front wheel angle sensor (5).
6. Disconnect the connector from the key stop solenoid (6).
7. Disconnect the connector from the engine revolution sensor (7).

- |                         |                              |
|-------------------------|------------------------------|
| (1) Flasher Unit        | (5) Front Wheel Angle Sensor |
| (2) Air Cleaner         | (6) Key Stop Solenoid        |
| (3) Glow Plug Cable     | (7) Engine Revolution Sensor |
| (4) <b>1P</b> Connector |                              |

9Y1211109ENS0027US0

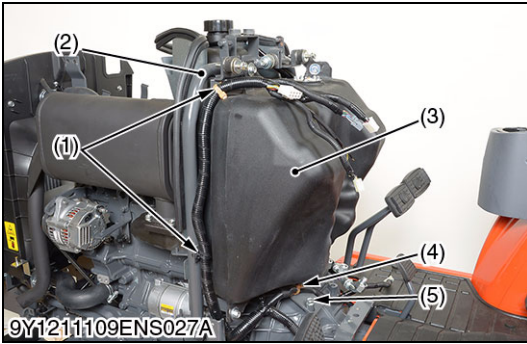

**Fuel Tank**

1. Pull out the clamps (1), (4).
2. Disconnect the overflow hoses from fuel tank (3).
3. Remove the screws (5), (6) and then remove the fuel tank (3) with pillar (2).

- |               |           |
|---------------|-----------|
| (1) Clamp     | (4) Clamp |
| (2) Pillar    | (5) Screw |
| (3) Fuel Tank | (6) Screw |

9Y1211109ENS0029US0

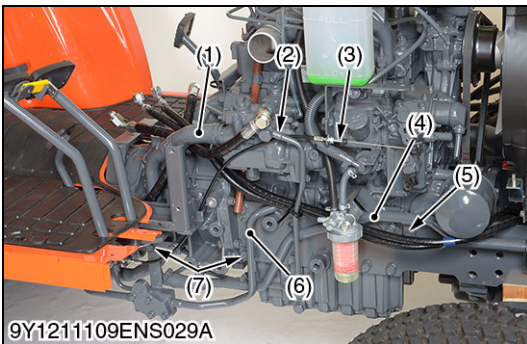
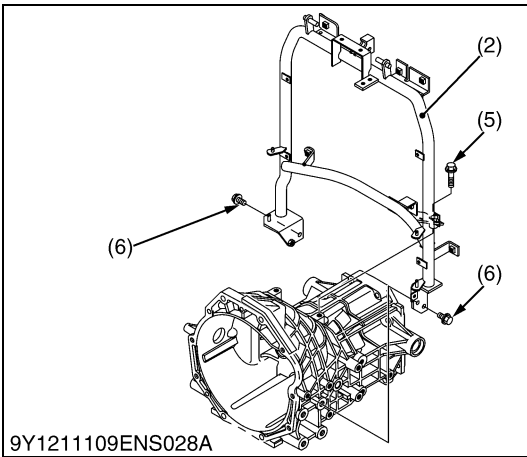

**Hydraulic Pipe and Hose**

1. Disconnect the accelerator wire (3) from the engine.
2. Remove the retaining screws (7) and separate the **3P** hydraulic delivery pipe (6) from the hydraulic pump.
3. Disconnect the bi-speed delivery pipe (2) from the hydraulic pump.
4. Disconnect the oil cooler inlet hose (9) and outlet hose (8).
5. Remove the retaining screws (5), (10) and then disconnect the oil cooler pipe (4).
6. Disconnect the suction hose (1).

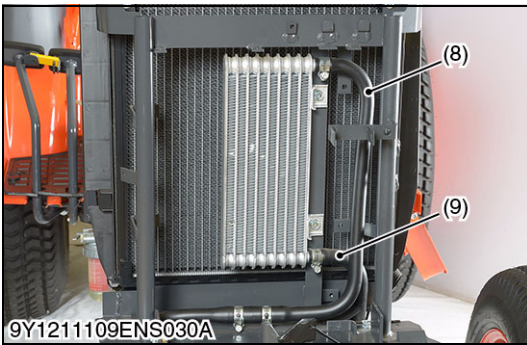

Tightening torque	Bi-speed delivery pipe joint screw (Pump side)	30 to 40 N·m 3.1 to 4.0 kgf·m 23 to 29 lbf·ft
	Bi-speed delivery pipe retaining nut (Bi-speed valve side)	29 to 49 N·m 3.0 to 5.0 kgf·m 21.7 to 36.2 lbf·ft

- |                            |                                       |
|----------------------------|---------------------------------------|
| (1) Suction Hose           | (6) <b>3P</b> Hydraulic Delivery Pipe |
| (2) Bi-speed Delivery Pipe | (7) Retaining Screw                   |
| (3) Accelerator Wire       | (8) Oil Cooler Outlet Hose            |
| (4) Oil Cooler Pipe        | (9) Oil Cooler Inlet Hose             |
| (5) Retaining Screw        | (10) Retaining Screw                  |

9Y1211109ENS0031US0

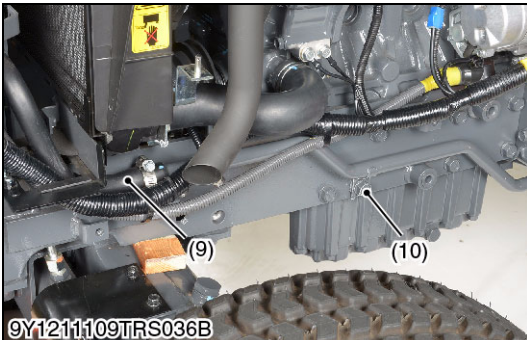

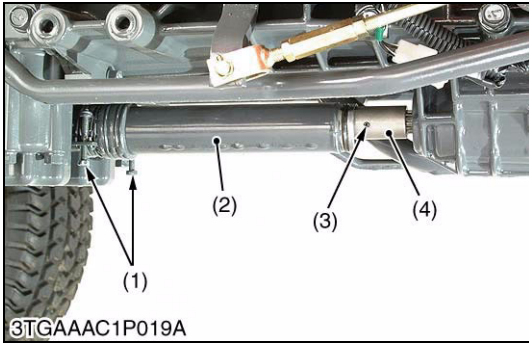

**Propeller Shaft**

1. Loosen the clamp screws (1) and slide the propeller shaft cover (2).
2. Tap out the spring pin (3) and then slide the coupling (4).
3. Remove the propeller shaft with the cover.

**(When reassembling)**

- Apply grease to the spline portion of the propeller shaft and couplings.
- When inserting the spring pins (3), face their splits in the direction parallel to the propeller shaft.
- Tighten the clamp screws (1) upward from the bottom side.

- |                           |                |
|---------------------------|----------------|
| (1) Clamp Screw           | (3) Spring Pin |
| (2) Propeller Shaft Cover | (4) Coupling   |

9Y1211109ENS0032US0



**Separating the Engine from Clutch Housing**

1. Place the disassembling stands under the clutch housing and engine oil pan.
2. Remove the starter.
3. Remove the engine mounting screws and nuts, and separate the engine from the clutch housing.

**(When reassembling)**

- Apply liquid gasket (Three Bond 1211 or equivalent) to joint face of the starter and rear end plate.
- Apply liquid gasket (Three Bond 1206C or equivalent) to joint face of the engine and clutch housing.

Tightening torque	Engine mounting screw, bolt and nut (M10)	48.1 to 55.9 N·m 4.9 to 5.7 kgf·m 35.5 to 41.2 lbf·ft
	Engine mounting nut (M12)	77.5 to 90.2 N·m 7.9 to 9.2 kgf·m 57.2 to 66.5 lbf·ft

9Y1211109ENS0033US0

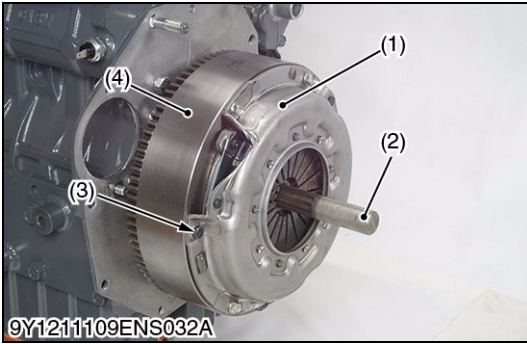

**Clutch Assembly**

1. Remove the clutch mounting screws and remove the clutch assembly (1) from the flywheel (4).

**(When reassembling)**

- Direct the shorter end of the clutch disc boss toward the flywheel (4).
- Apply molybdenum disulphide (Three Bond 1901 or equivalent) to the splines of clutch disc boss.
- Screws in two reamer screws (3) in the reamer screw holes (7).
- After tightening the reamer screws (3), tighten the other general screws.

**■ IMPORTANT**

- **Align the center of clutch disc (5) and flywheel (4) by inserting the clutch center tool (2).**

**■ NOTE**

- **Do not allow grease and oil on the clutch disc facing.**
- **The reamer screw hole (7) on the clutch cover is in the next of the 5 mm (0.2 in.) dia. hole.**
- **The shape of the reamer screw hole (7) on the flywheel (4) is different from other screw holes.**

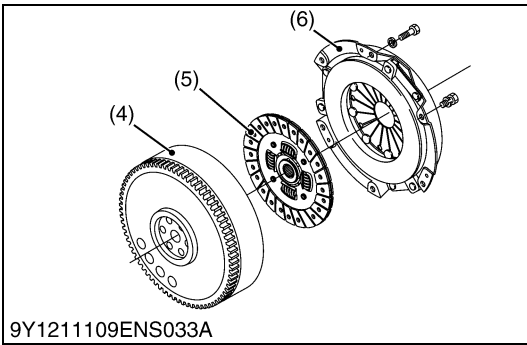

Tightening torque	Clutch mounting screw	23.5 to 27.5 N·m
		2.4 to 2.8 kgf·m
		17.4 to 20.2 lbf·ft

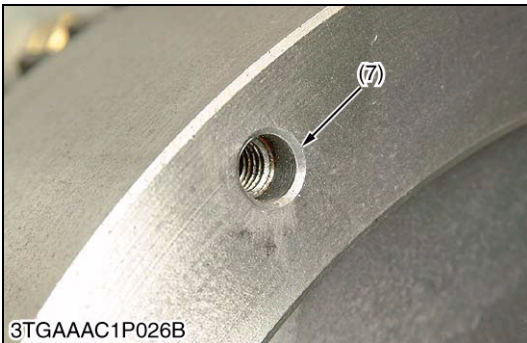

- |                        |                                 |
|------------------------|---------------------------------|
| (1) Clutch Assembly    | (5) Clutch Disc                 |
| (2) Clutch Center Tool | (6) Clutch Cover                |
| (3) Reamer Screw       | (7) Screw Hole for Reamer Screw |
| (4) Flywheel           |                                 |

9Y1211109ENS0034US0

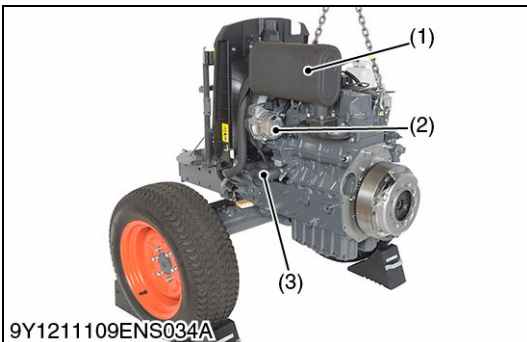

**Separating Front Axle Assembly and Outer Parts**

1. Remove the muffler (1).
2. Remove the alternator (2).
3. Disconnect the radiator hoses (3), (4).
4. Remove the recovery tank (5) with stay.
5. Remove the fuel filter (6).
6. Remove the hydraulic pump (7) with regulator valve.
7. Remove the engine mounting screws and separate the front axle assembly from engine.

**(When reassembling)**

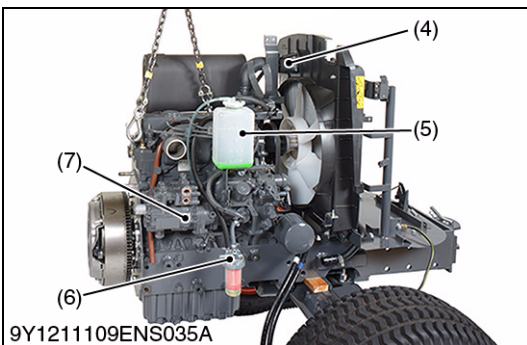

Tightening torque	Muffler mounting screw	32 to 37 N·m 3.2 to 3.8 kgf·m 24 to 27 lbf·ft
	Front axle frame mounting screw (M12)	78 to 90 N·m 7.9 to 9.2 kgf·m 58 to 66 lbf·ft

- |                         |                    |
|-------------------------|--------------------|
| (1) Muffler             | (5) Recovery Tank  |
| (2) Alternator          | (6) Fuel Filter    |
| (3) Radiator Lower Hose | (7) Hydraulic Pump |
| (4) Radiator Upper Hose |                    |

9Y1211109ENS0035US0

## (2) Separating Engine from Tractor for CABIN

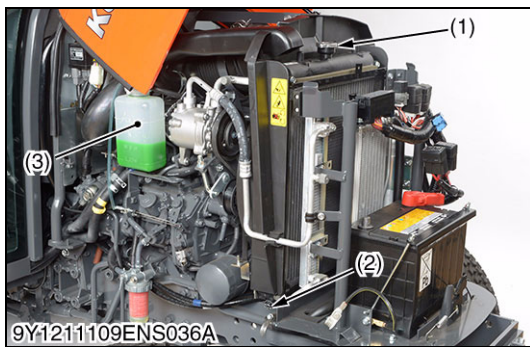
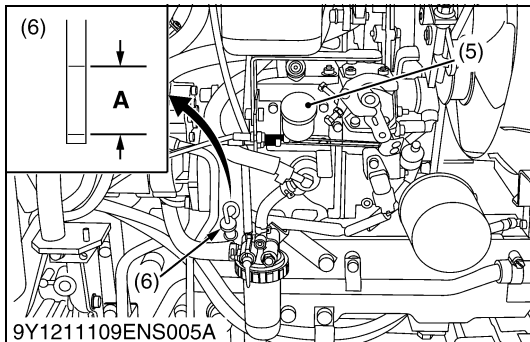
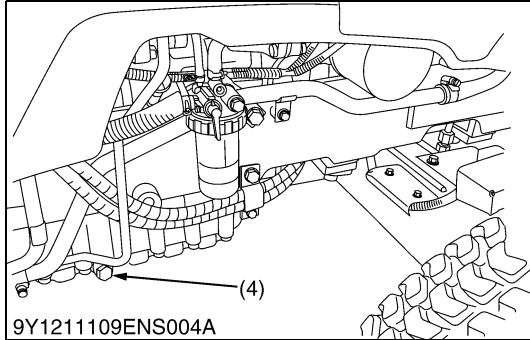
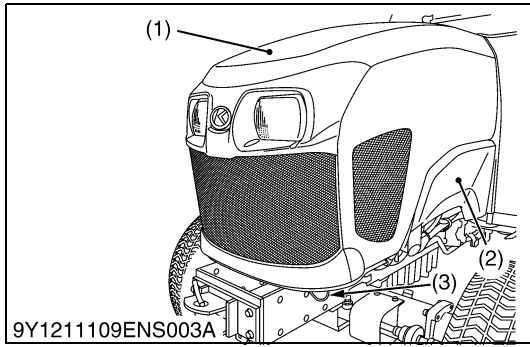

### Draining Engine Oil

1. Place an oil pan underneath the engine.
2. To open the hood (1), hold the hood (1) and pull the release lever (3) and open the hood (1).
3. Remove the bolt from each of the side covers (2) and remove the side covers (2).
4. To drain the oil, remove the both drain plugs (4) at the bottom of the engine and drain the oil completely into the oil pan.
5. After draining, reinstall the both drain plugs (4).

#### (When reassembling)

- Fill with the new engine oil up to the upper notch on the dipstick (6).

#### ■ IMPORTANT

- When using an oil of different manufacture or viscosity from the previous one, remove all of the old oil.
- Never mix two different types of oil.
- Use the proper SAE Engine Oil according to ambient temperatures.
- Refer to "4. LUBRICANTS, FUEL AND COOLANT" on page G-8.

Engine Oil	Capacity	STW34	5.7 L 6.0 U.S.qts 5.0 Imp.qts
		STW37, STW40	6.7 L 7.1 U.S.qts 5.9 Imp.qts

- |                   |  |
|-------------------|--|
| (1) Hood          | (5) Oil Inlet  |
| (2) Side Cover    | (6) Dipstick   |
| (3) Release Lever | <b>A: Oil level is acceptable within this range.</b> |
| (4) Drain Plug    |  |

9Y1211109ENS0018US0

### Draining Coolant

#### ⚠ WARNING

To avoid personal injury or death:

- Do not remove the radiator cap while coolant is hot. When cool, slowly rotate cap to the first stop and allow sufficient time for excess pressure to escape before removing the cap completely.

1. Stop the engine and let it cool down.
2. To drain the coolant, open the radiator drain plug (2) and remove radiator cap (1). The radiator cap (1) must be removed to completely drain the coolant.
3. After all coolant is drained, reinstall the drain plug (2).

Coolant (with recovery tank)	Capacity	7.1 L
		7.5 U.S.qts 6.2 Imp.qts

- |                  |                   |
|------------------|-------------------|
| (1) Radiator Cap | (3) Recovery Tank |
| (2) Drain Plug   |                   |

9Y1211109ENS0036US0

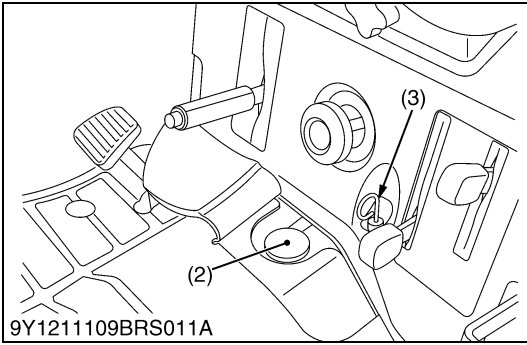
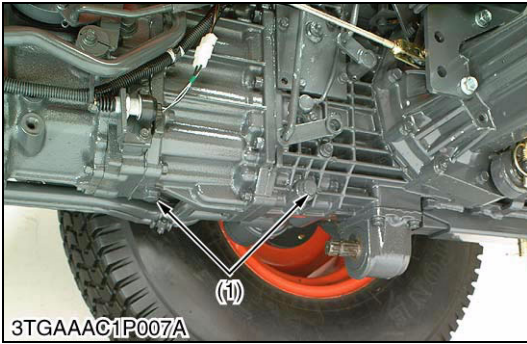

**Draining Transmission Fluid**

1. Place an oil pan underneath the transmission case, and remove the drain plugs (1).
2. Drain the transmission fluid.
3. Reinstall the drain plugs (1).

**(When reassembling)**

- Fill new oil from filling port after removing the filling plug (2) up to the upper notch on the dipstick (3).
- After running the engine for few minutes, stop it and check the oil level again, if low, add oil prescribed level.

**■ IMPORTANT**

- **Use only KUBOTA SUPER UDT fluid. Use of other oils may damage the transmission or hydraulic system. Refer to "4. LUBRICANTS, FUEL AND COOLANT" on page G-8.**
- **Never work the tractor immediately after changing the transmission oil. Keeping the engine at medium speed for a few minutes to prevents damage to the transmission.**
- **Do not mix different brands oil together.**

Transmission fluid	Capacity	24 L 6.3 U.S.gals 5.3 Imp.gals
--------------------	----------	--------------------------------------

- (1) Drain Plug (3) Dipstick  
(2) Filling Plug

9Y1211109ENS0131US0



**Rear Wheel and 3-Point Linkage**

1. Place the disassembling stand under the transmission case.
2. Remove the rear wheels (1).
3. Remove the top link (2), lift rods (3) and lower links (4).
4. Remove the drawbar (5).

Tightening torque	Rear wheel mounting screw and nut	196.1 to 225.6 N·m 20.0 to 23.0 kgf·m 145 to 166 lbf·ft
-------------------	-----------------------------------	---

- (1) Rear Wheel (4) Lower Link  
(2) Top Link (5) Drawbar  
(3) Lift Rod

9Y1211109ENS0037US0

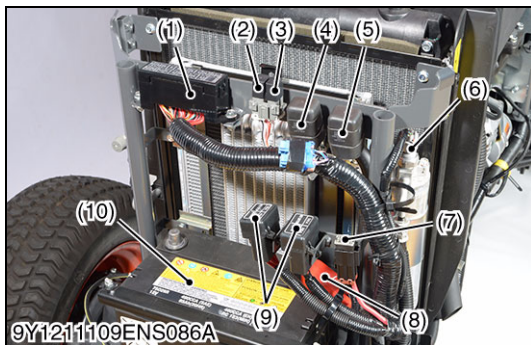
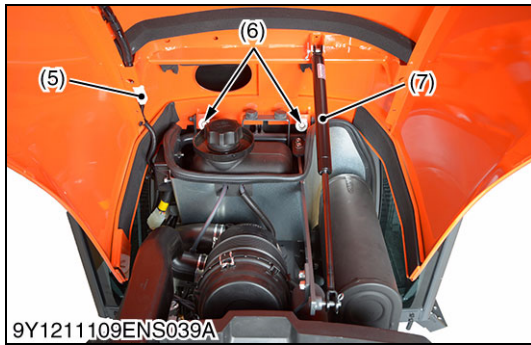
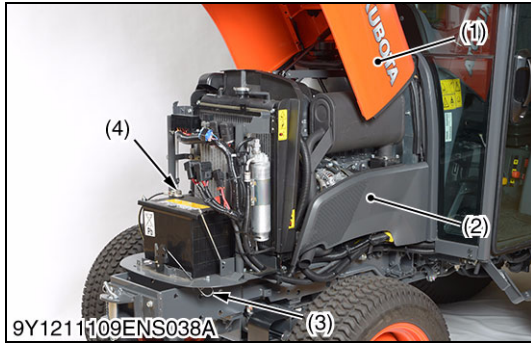

**Hood, Side Cover and Battery Cord**

1. To open the hood (1), hold the hood (1) and pull the release lever (3) and open the hood (1).
2. Remove the bolt from each of the side covers (2) and remove the side covers (2).
3. Disconnect the battery negative cable (4).
4. Disconnect the head light connector (5) and damper (7).
5. Remove the two screws (6) and then remove the hood (1).

**(When reassembling)**

■ **NOTE**

- **When disconnecting the battery cords, disconnect the grounding cord first. When connecting, positive cord first.**

- |                            |                          |
|----------------------------|--------------------------|
| (1) Hood                   | (5) Head Light Connector |
| (2) Side Cover             | (6) Screw                |
| (3) Release Lever          | (7) Damper               |
| (4) Battery Negative Cable |                          |

9Y1211109ENS0038US0

**Wiring Harness**

1. Remove the slow blow fuses (7), (9).
2. Disconnect the battery positive cable (8) from the battery (10).
3. Remove the fuse box (1).
4. Disconnect the relays (2), (3).
5. Remove the electrical outlet relay (4).
6. Remove the key stop relay (5).
7. Disconnect the pressure switch (6).
8. Remove the battery (10).

- |                             |                                 |
|-----------------------------|---------------------------------|
| (1) Fuse Box                | (6) Pressure Switch             |
| (2) Head Light Relay        | (7) Slow Blow Fuse For Defogger |
| (3) Flasher Relay           | (8) Battery Positive Cable      |
| (4) Electrical Outlet Relay | (9) Slow Blow Fuse              |
| (5) Key Stop Relay          | (10) Battery                    |

9Y1211109ENS0132US0

**Steering Wheel**

1. Remove the covers (3).
2. Remove the steering wheel cap.
3. Remove the steering wheel mounting nut (1) and remove the steering wheel (2) with a steering wheel puller (Code No. 07916-51090).

**(When reassembling)**

Tightening torque	Steering wheel mounting nut	48.1 to 55.9 N·m 4.9 to 5.7 kgf·m 35.4 to 41.2 lbf·ft
-------------------	-----------------------------	---

- |                                 |           |
|---------------------------------|-----------|
| (1) Steering Wheel Mounting Nut | (3) Cover |
| (2) Steering Wheel              |           |

9Y1211109ENS0039US0

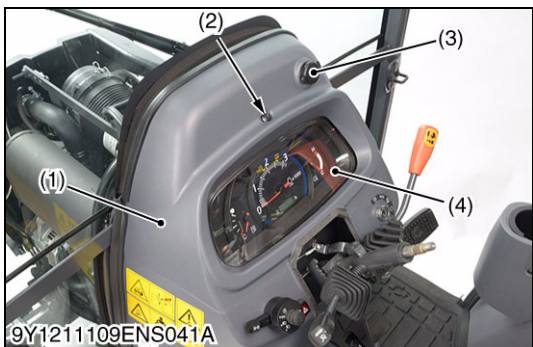

**Instrument Panel and Panel Under Cover**

1. Remove the screw (2).
2. Open the panel cover (1) and disconnect the electrical outlet connector (5).
3. Open the instrument panel (4) and disconnect the instrument panel connector (6). Then remove the instrument panel (4).

- |                       |                                 |
|-----------------------|---------------------------------|
| (1) Panel Cover       | (4) Instrument Panel            |
| (2) Screw             | (5) Electrical Outlet Connector |
| (3) Electrical Outlet | (6) Instrument Panel Connector  |

9Y1211109ENS0040US0

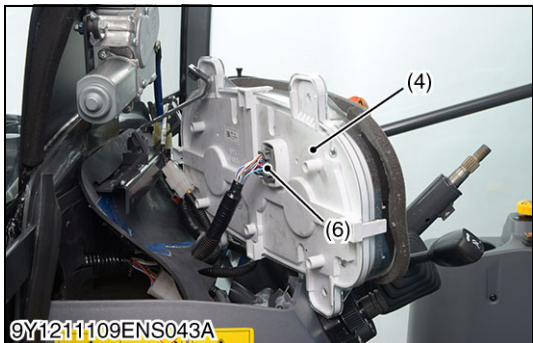
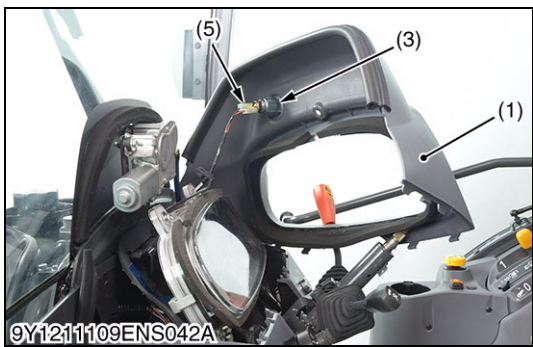



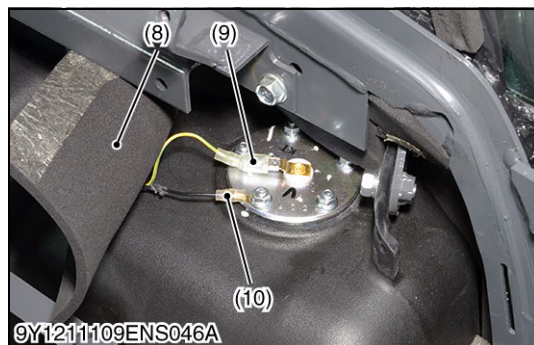
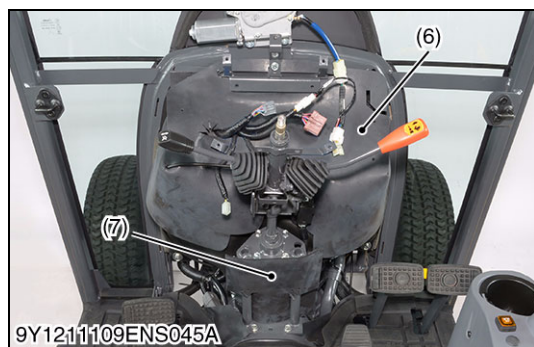
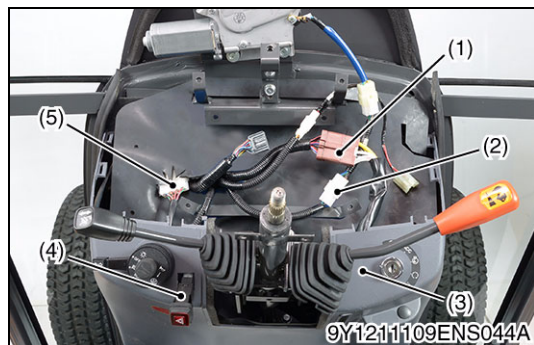

### Wiring Harness

1. Disconnect the combination switch connector (5), main switch connector (1), hazard switch connector (4) and wiper motor connector (2).
2. Remove the panel under cover (3).
3. Remove the rubbers (6), (7).
4. Turn over the fuel level sensor cover (8).
5. Disconnect the grounding wire (10) and **1P** connector (9) from the fuel level sensor.

- |                                  |                             |
|----------------------------------|-----------------------------|
| (1) Main Switch Connector        | (6) Rubber                  |
| (2) Wiper Motor Connector        | (7) Rubber                  |
| (3) Panel Under Cover            | (8) Fuel Level Sensor Cover |
| (4) Hazard Switch Connector      | (9) <b>1P</b> Connector     |
| (5) Combination Switch Connector | (10) Grounding Wire         |

9Y1211109ENS0041US0

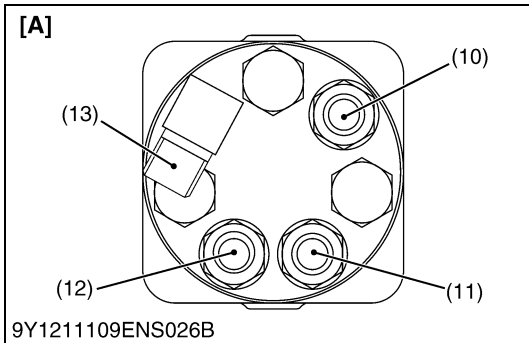
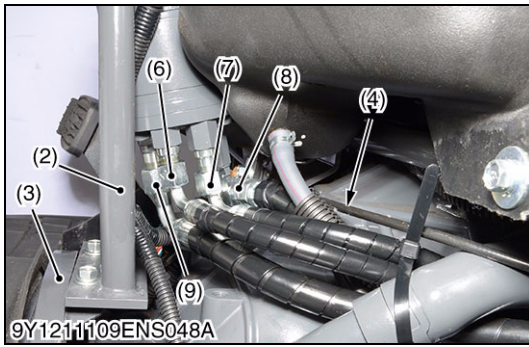
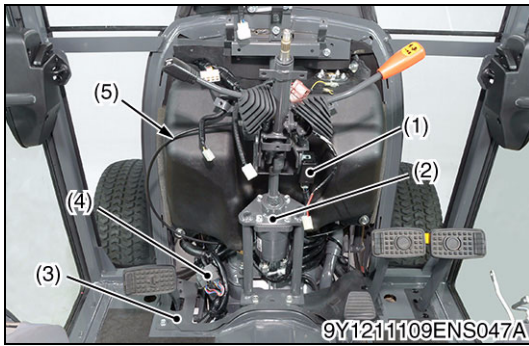

**Power Steering Hoses and Steering Support**

1. Disconnect the accelerator wire (5) from the engine.
2. Disconnect the OPC controller connector (1) and CABIN joint connectors (4).
3. Remove the step cover (3).
4. Disconnect the delivery hose L.H. (6) and delivery hose R.H. (7) from the steering controller.
5. Disconnect the power steering delivery hose (9) from the steering controller.
6. Disconnect the power steering return hose (8) from the steering controller.
7. Remove the steering support (2) with the steering controller.

**(When reassembling)**

- Be sure to connect the each hose to original position.
- Be sure to check the hose joints do not interfere in other joints.

Tightening torque	Delivery hose R.H. (4) retaining nut	24.5 to 29.4 N·m 2.5 to 3.0 kgf·m 18.1 to 21.7 lbf·ft
	Delivery hose L.H. (3) retaining nut	24.5 to 29.4 N·m 2.5 to 3.0 kgf·m 18.1 to 21.7 lbf·ft
	Return hose retaining nut	34.3 to 44.1 N·m 3.5 to 4.5 kgf·m 25.3 to 32.5 lbf·ft
	Delivery hose joint screw	45.1 to 53.0 N·m 4.60 to 5.40 kgf·m 33.3 to 39.0 lbf·ft

- |                              |                                  |
|------------------------------|----------------------------------|
| (1) OPC Controller Connector | (8) Power Steering Return Hose   |
| (2) Steering Support         | (9) Power Steering Delivery Hose |
| (3) Step Cover               | (10) P Port                      |
| (4) CABIN Joint Connector    | (11) LT Port                     |
| (5) Accelerator Wire         | (12) RT Port                     |
| (6) Delivery Hose L.H.       | (13) T Port                      |
| (7) Delivery Hose R.H.       |                                  |
- [A] Viewed from Bottom Side**

9Y1211109ENS0042US0

**Step Mat and Seat Under Cover**

1. Remove the step mat (3), sound absorber (2) and rubber (1).
2. Remove the grips of the mid PTO lever (7) and front wheel drive lever (8).
3. Remove the dipstick (6).
4. Remove the lowering speed adjusting knob (5).
5. Remove the seat under cover (4).

**(When reassembling)**

- Do not confuse the grips.
  - Grip (yellow) for the mid PTO lever (7).
  - Grip (red) for the front wheel drive lever (8).

- |                      |                                   |
|----------------------|-----------------------------------|
| (1) Rubber           | (5) Lowering Speed Adjusting Knob |
| (2) Sound Absorber   | (6) Dipstick                      |
| (3) Step Mat         | (7) Mid PTO Lever                 |
| (4) Seat Under Cover | (8) Front Wheel Drive Lever       |

9Y1211109ENS0043US0

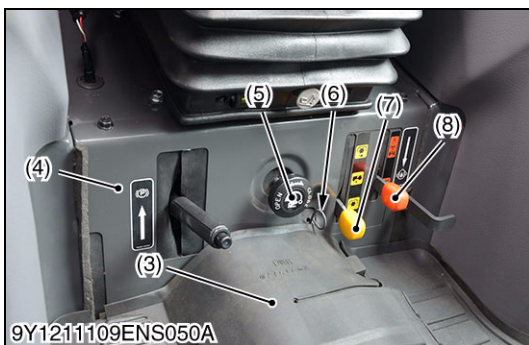
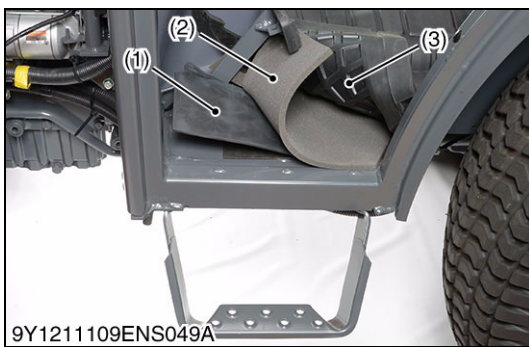

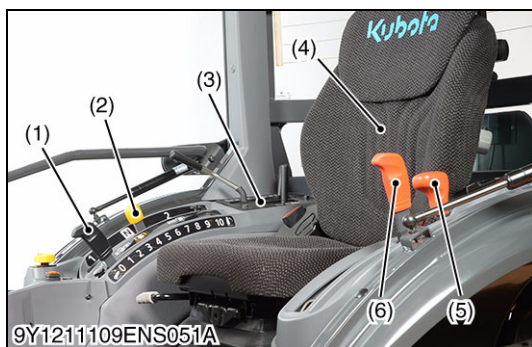

### Seat and Lever Grip

1. Disconnect the seat switch connector (7) and remove the seat (4).
2. Remove the grips of the rear PTO shift lever (2), position control lever (1), cruise control lever (5) and range gear shift lever (6).
3. Remove the remote control lever guide (3).

#### (When reassembling)

- Do not confuse the grips.
  - Grip (yellow) for the rear PTO shift lever (2).
  - Grip (red) for the range gear shift lever (6).

- |                                 |                                 |
|---------------------------------|---------------------------------|
| (1) Position Control Lever Grip | (5) Cruise Control Lever Grip   |
| (2) Rear PTO Shift Lever Grip   | (6) Range Gear Shift Lever Grip |
| (3) Remote Control Lever Guide  | (7) Seat Switch Connector       |
| (4) Seat                        |                                 |

9Y1211109ENS0044US0

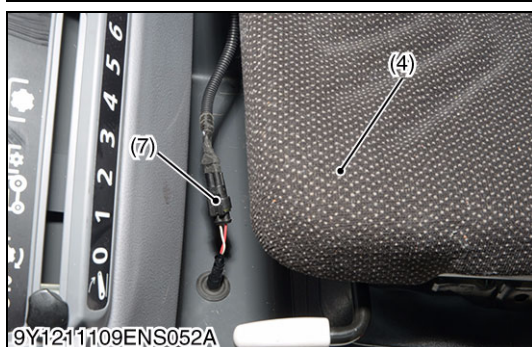

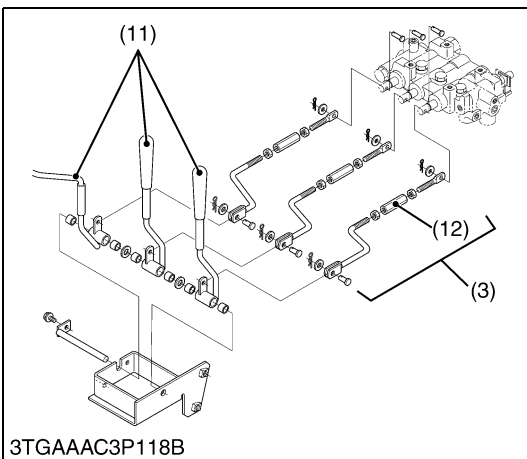
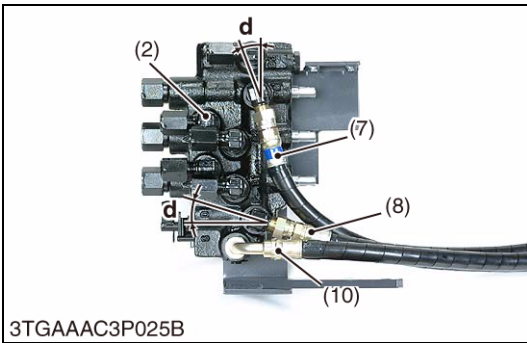
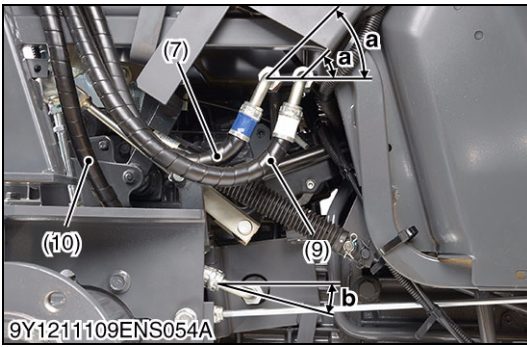
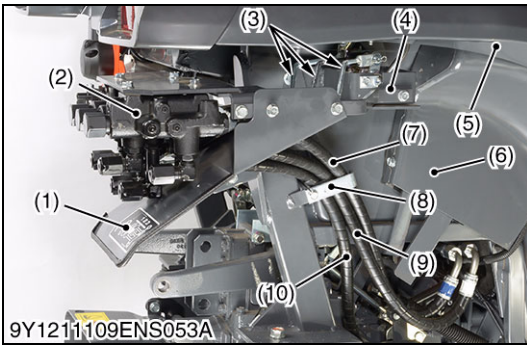

**Auxiliary Control Valve and Covers**

1. Remove the valve cover (1).
2. Remove the valve stay (4).
3. Remove the connecting rods (3).

**(When reassembling)**

- Reassemble the connecting rods (3) as shown in the figure.
- After reassembling the valve stay (4), adjust to locate the control lever (11) at a central position of the guide slot with the turnbuckle (12).

4. Remove the hose clamp (8).

**(When reassembling)**

- Clamp the hydraulic hoses in order of hydraulic hose **PB** (7), hydraulic hose **P** (9) and hydraulic hose **T** (10) from the front side.

5. Disconnect the hydraulic hoses (7), (9), (10) from the tractor body.

6. Remove the auxiliary control valve (2) with the hydraulic hoses (7), (9), (10).

7. Remove the remote control lever bracket with the remote control lever (11).

**(When reassembling)**

- Assemble the hose joints to appropriate positions referring to the table below.

8. Remove the fender under cover (5) and fender cover (6).

**(Distinction and installation angle of the hose joints)**

Hydraulic Hose	Hose Joint (Valve side)	Hose Joint (Tractor body side)
<b>P</b> (9)	Straight joint 0.26 rad (15 °)	Bent joint with white tape 0.785 rad (45 °)
<b>PB</b> (7)	Straight joint with blue tape 0.26 rad (15 °)	Bent joint with blue tape 0.785 rad (45 °)
<b>T</b> (10)	Bent joint 1.57 rad (90 °)	Bent joint 0.349 to 0.523 rad (20 to 30 °)
Tightening torque	Hydraulic hose <b>PB</b> , <b>P</b> and <b>T</b> retaining nuts	30 to 40 N·m 3.1 to 4.0 kgf·m 23 to 29 lbf·ft

- |   |   |
|---|---|
| <ol style="list-style-type: none"> <li>(1) Valve Cover</li> <li>(2) Auxiliary Control Valve</li> <li>(3) Connecting Rod</li> <li>(4) Valve Stay</li> <li>(5) Fender Under Cover</li> <li>(6) Fender Cover</li> <li>(7) Hydraulic Hose <b>PB</b></li> <li>(8) Hose Clamp</li> <li>(9) Hydraulic Hose <b>P</b></li> </ol> | <ol style="list-style-type: none"> <li>(10) Hydraulic Hose <b>T</b></li> <li>(11) Remote Control Lever</li> <li>(12) Turnbuckle</li> </ol> <p> <b>a: 0.785 rad (45 °)</b><br/> <b>b: 0.349 to 0.523 rad (20 to 30 °)</b><br/> <b>c: 0.26 rad (15 °)</b><br/> <b>d: 0.26 rad (15 °)</b> </p> |
|---|---|

9Y1211109ENS0045US0



### **Fender Assembly**

1. Remove the fender cover (1).
2. Remove the sponges (4), (5).

#### **(When reassembling)**

- Assemble the sponge (center) (4) between the cruise control lever (2) and range gear shift lever (6).

- |                          |                            |
|--------------------------|----------------------------|
| (1) Fender Cover         | (4) Sponge (Center)        |
| (2) Cruise Control Lever | (5) Sponge (Outer)         |
| (3) Sponge (Inner)       | (6) Range Gear Shift Lever |

9Y1211109ENS0046US0

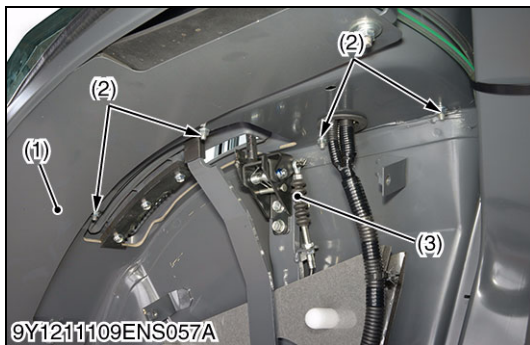
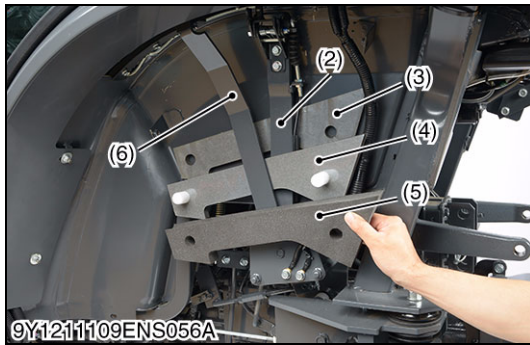

### **Release Wire and Wiring Harness (Left Side)**

1. Remove the fender under cover (1).
2. Remove the release wire (3).
3. Remove the lever guide mounting screws (2), and then open the lever guide (4).
4. Disconnect the wiring connectors for the bi-speed controller connectors (5) and electrical outlet connector (6).
5. Remove the lever guide (4) with bi-speed controller.

- |                                   |                                   |
|-----------------------------------|-----------------------------------|
| (1) Fender Under Cover            | (4) Lever Guide                   |
| (2) Lever Guide Mounting Screw    | (5) Bi-speed Controller Connector |
| (3) Release Wire (Cruise Control) | (6) Electrical Outlet Connector   |

9Y1211109ENS0047US0

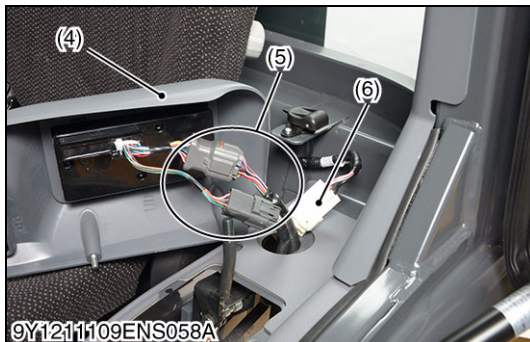



**Wiring Harness (Right Side)**

1. Remove the loader lever guide mounting screws (1).
2. Open the loader lever guide (2) and then disconnect the connectors for PTO switch (4) and beacon switch (3).

- |                                       |                   |
|---------------------------------------|-------------------|
| (1) Loader Lever Guide Mounting Screw | (3) Beacon Switch |
| (2) Loader Lever Guide                | (4) PTO Switch    |

9Y1211109ENS0049US0



**Wiring Harness**

1. Pull down the grommet (1) for seat switch connector.
2. Remove the clamp (2).

- |             |           |
|-------------|-----------|
| (1) Grommet | (2) Clamp |
|-------------|-----------|

9Y1211109ENS0050US0

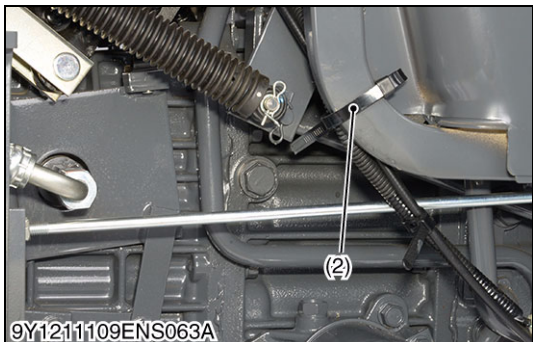
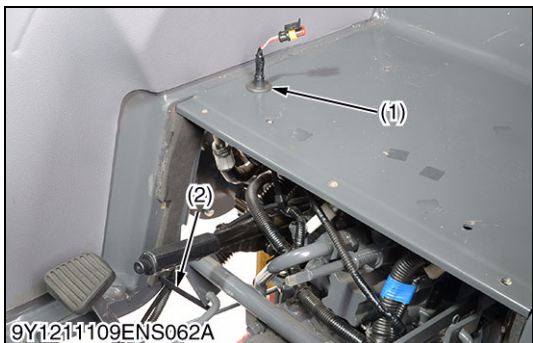

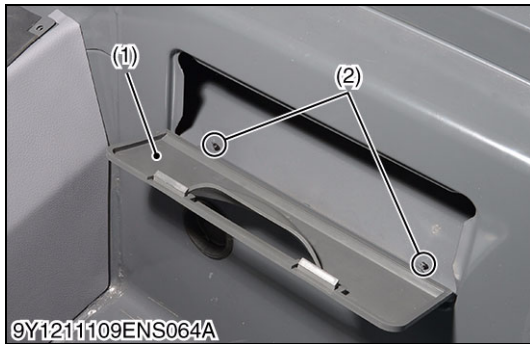

**Wiring Harness (Rear Side)**

1. Open the tool box (1).
2. Remove the clamps (2), (3) from the Cabin.
3. Disconnect the registration lamp connectors (4).
4. Disconnect the washer motor connectors (5).
5. Disconnect the PTO switch connector (6).

**(When reassembling)**

- Do not confuse the connectors.
  - Connector (white) for the front washer motor.
  - Connector (gray) for the rear washer motor.

- |              |                                 |
|--------------|---------------------------------|
| (1) Tool Box | (4) Registration Lamp Connector |
| (2) Clamp    | (5) Washer Motor Connector      |
| (3) Clamp    | (6) PTO Switch Connector        |

9Y1211109ENS0051US0

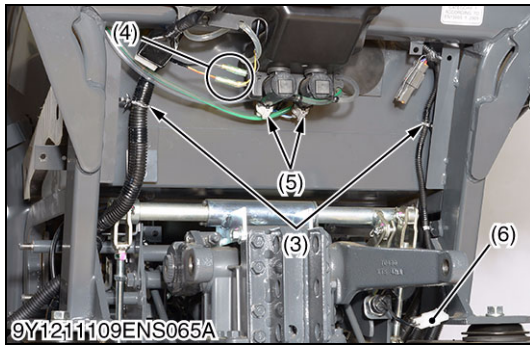

**Differential Lock Pedal and Levers**

1. Remove the differential lock pedal (1) with the spring (2).
2. Remove the grounding cable (6) mounting screws.
3. Remove the plate (3).
4. Remove the range gear shift lever (4) and cruise control lever (5).

- |                             |                            |
|-----------------------------|----------------------------|
| (1) Differential Lock Pedal | (4) Range Gear Shift Lever |
| (2) Spring                  | (5) Cruise Control Lever   |
| (3) Plate                   | (6) Grounding Cable        |

9Y1211109ENS0048US0

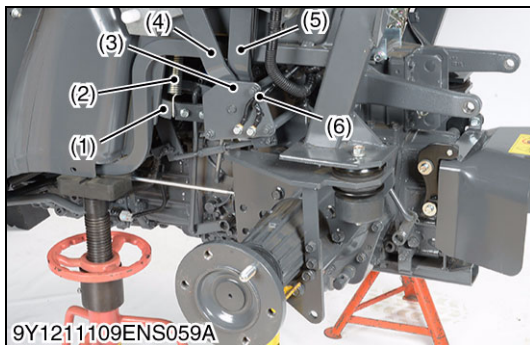

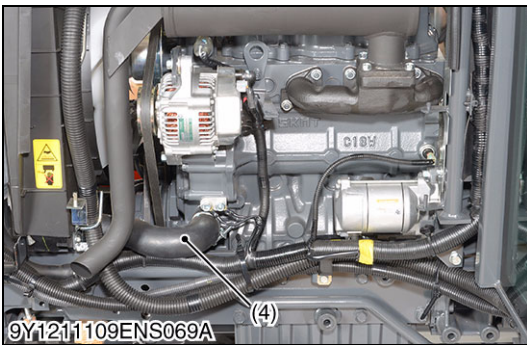
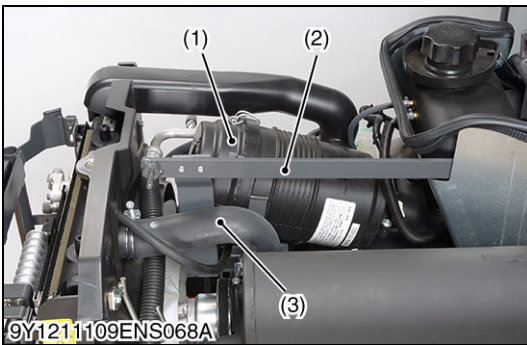
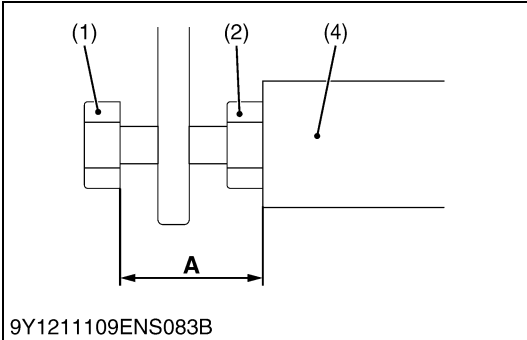
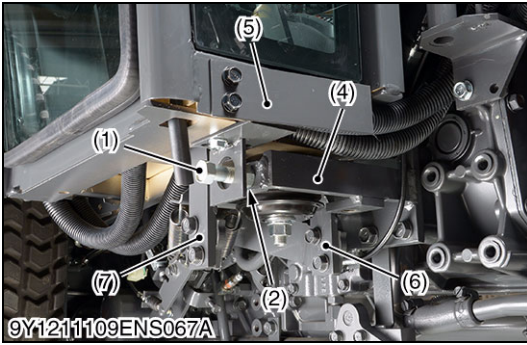
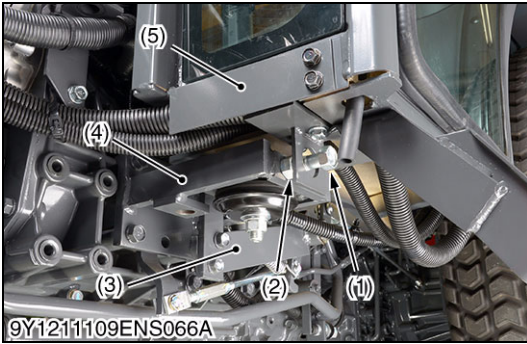

**Clutch Pedal, Brake Pedal and Cabin Stopper Bolt**

1. Remove the both sides of hose plate (5).
2. Remove the clutch pedal (3).
3. Remove the brake pedal L.H. (6) and R.H. (7)
4. Loosen the both sides of lock nut (2), and then remove the both sides of stopper bolt (1)

**(When reassembling)**

- Be sure to install the stopper bolt to the original positions.

- |                   |  |
|-------------------|--|
| (1) Stopper Bolt  | (5) Hose Plate                         |
| (2) Lock Nut      | (6) Brake Pedal L.H.                   |
| (3) Clutch Pedal  | (7) Brake Pedal R.H.                   |
| (4) Front Bracket | <b>A: 38 to 42 mm (1.5 to 1.6 in.)</b> |

9Y1211109ENS0052US0

**Air Cleaner and Radiator Hoses**

1. Remove the air cleaner (1) with air cleaner hose.
2. Remove the damper stay (2)
3. Remove the radiator upper hose (3) and lower hose (4).

- |                 |                         |
|-----------------|-------------------------|
| (1) Air Cleaner | (3) Radiator Upper Hose |
| (2) Damper Stay | (4) Radiator Lower Hose |

9Y1211109ENS0053US0



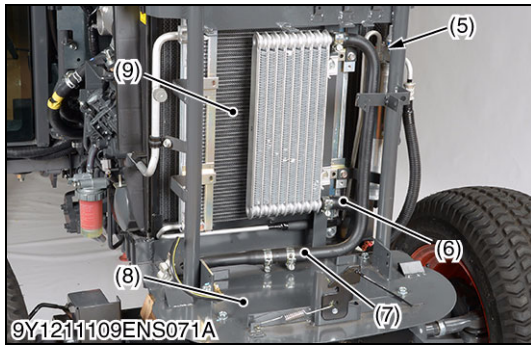
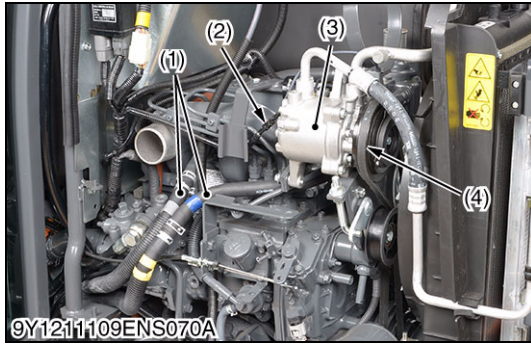

**Air Compressor and Oil Hoses**

1. Disconnect the heater hoses (1), and then reconnect their hoses to make loop.
- **NOTE**
  - **Put a mark to the each heater hose before disconnecting.**
2. Remove the air conditioner belt (4).
3. Disconnect the compressor **1P** connector (2).
4. Disconnect the oil cooler inlet hose (6) and outlet hose (7).
5. Remove the battery stay mounting bolt.
6. Remove the compressor mounting screws.
7. Remove the compressor (3), condenser (9), receiver (5), battery stay (8) and etc. as a unit.

**(When reassembling)**

- After reassembling the compressor, be sure to adjust the air conditioner belt tension. (See page G-31.)

- |                                    |                            |
|------------------------------------|----------------------------|
| (1) Heater Hose                    | (6) Oil Cooler Inlet Hose  |
| (2) Compressor <b>1P</b> Connector | (7) Oil Cooler Outlet Hose |
| (3) Compressor                     | (8) Battery Stay           |
| (4) Air Conditioner Belt           | (9) Condenser              |
| (5) Receiver                       |                            |

9Y1211109ENS0054US0

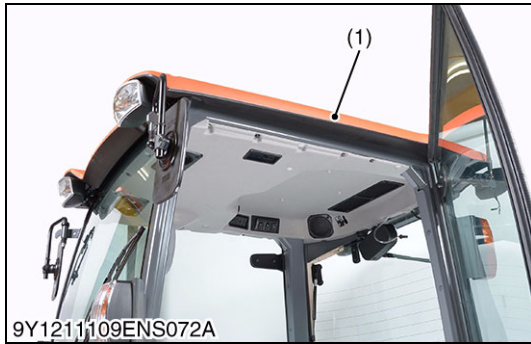

**Cabin Assembly**

1. Remove the outer roof (1) of cabin.
2. Support the cabin with nylon straps (2), cabin dismantling tool (3) and hoists.
3. Loosen and remove the cabin mounting screw (4) and nuts (10).
4. Dismounting the cabin from tractor body.

■ **NOTE**

- **Lift the cabin while making sure it does not catch on anything.**

**(When reassembling)**

- Be sure to install the washers and mount rubbers, etc. in their original positions.

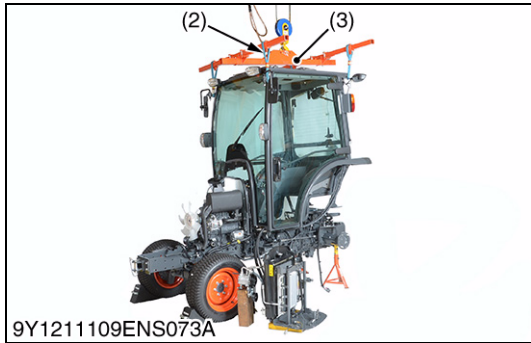

Tightening torque	Outer roof mounting screw	3.5 to 4.0 N·m 0.36 to 0.40 kgf·m 2.6 to 2.9 lbf·ft
	Cabin mounting bolt and nut	124 to 147 N·m 12.6 to 15.0 kgf·m 91.1 to 108 lbf·ft

- |                            |                      |
|----------------------------|----------------------|
| (1) Outer Roof             | (8) Plane Washer     |
| (2) Nylon Strap            | (9) Spring Washer    |
| (3) Cabin Dismounting Tool | (10) Nut             |
| (4) Screw                  | (11) Collar          |
| (5) Plate                  |                      |
| (6) Mount Rubber           | <b>F: Front Side</b> |
| (7) Collar                 | <b>R: Rear Side</b>  |

9Y1211109ENS0055US0

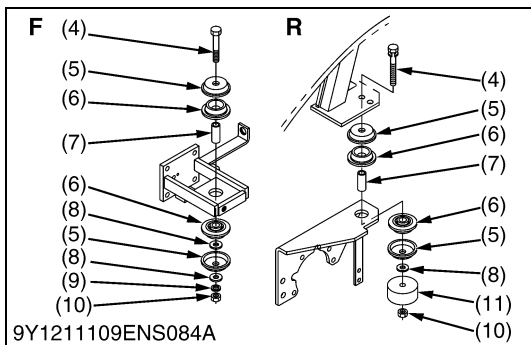

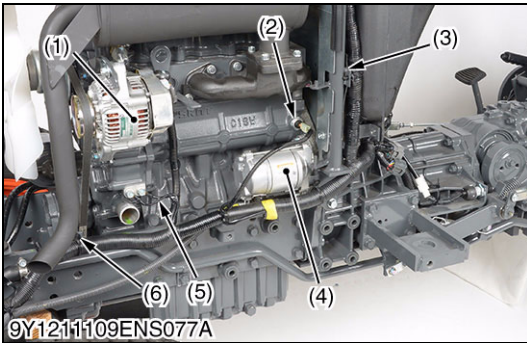
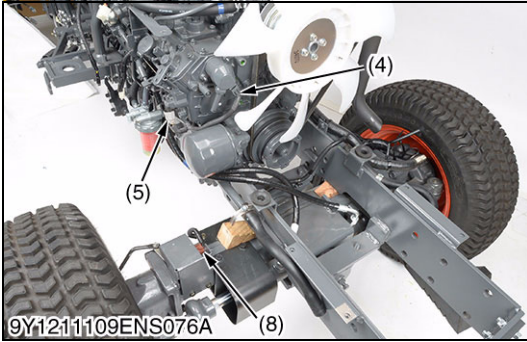
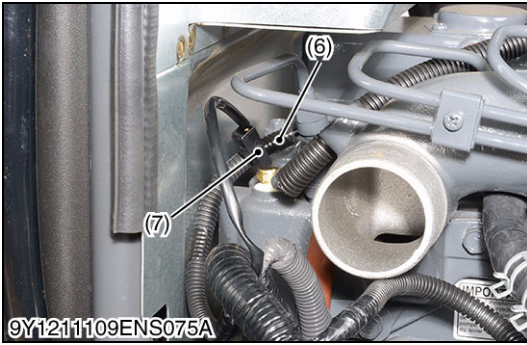
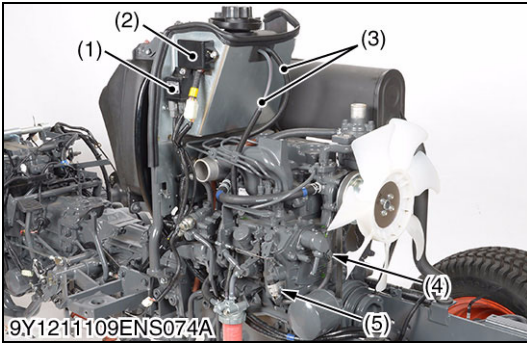

**Wiring Harness (Right Side)**

1. Disconnect the connectors for QGS controller (1) and flasher unit (2).
2. Disconnect the coolant temperature sensor connector (7) and glow plug cable (6).
3. Disconnect the connector for key stop solenoid (4), engine revolution sensor (5) and front wheel angle sensor (8).
4. Disconnect the fuel return hoses (3) from the fuel tank.

- |                       |                                |
|-----------------------|--------------------------------|
| (1) QGS Controller    | (5) Engine Revolution Sensor   |
| (2) Flasher Unit      | (6) Glow Plug Cable            |
| (3) Fuel Return Hose  | (7) Coolant Temperature Sensor |
| (4) Key Stop Solenoid | (8) Front Wheel Angle Sensor   |

9Y1211109ENS0056US0

**Wiring Harness (Left Side)**

1. Disconnect the connectors from the alternator (1), starter (4), coolant temperature sensor and oil switch (2).
2. Disconnect the grounding terminal (5).
3. Remove the clamps (3), (6).
4. Set aside the main harness to the rear.

- |                |                        |
|----------------|------------------------|
| (1) Alternator | (4) Starter            |
| (2) Oil Switch | (5) Grounding Terminal |
| (3) Clamp      | (6) Clamp              |

9Y1211109ENS0057US0

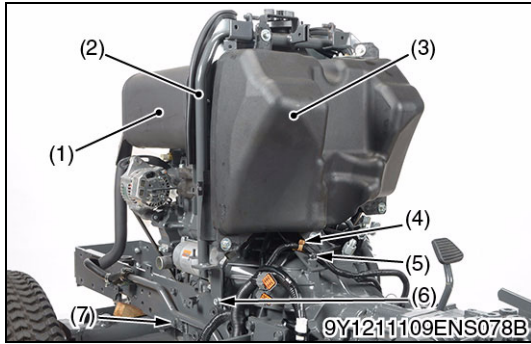

**Fuel Tank and Muffler**

1. Remove the muffler (1).
2. Pull out the clamps (4).
3. Remove the screws (5), (6) and then remove the fuel tank (3) with pillar (2).
4. Remove the retaining screw (7).

**(When reassembling)**

Tightening torque	Muffler mounting screw	32 to 37 N·m 3.2 to 3.8 kgf·m 24 to 27 lbf·ft
-------------------	------------------------	---

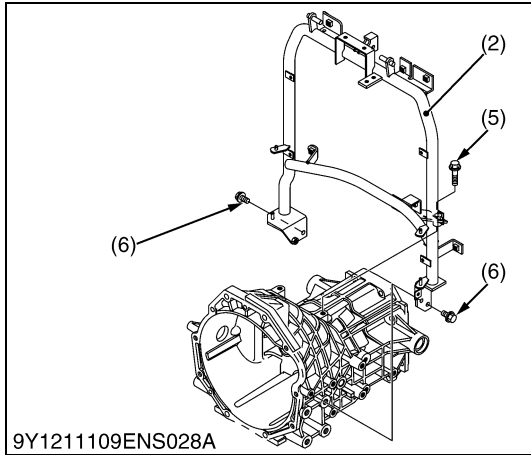

- |               |                     |
|---------------|---------------------|
| (1) Muffler   | (5) Screw           |
| (2) Pillar    | (6) Screw           |
| (3) Fuel Tank | (7) Retaining Screw |
| (4) Clamp     |                     |

9Y1211109ENS0058US0

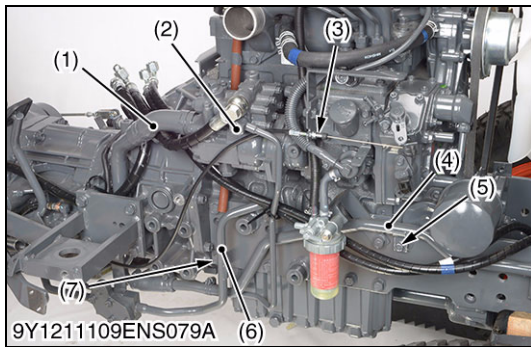

**Hydraulic Pipe and Hose**

1. Disconnect the suction hose (1) from the engine.
2. Remove the retaining screws (7) and separate the **3P** hydraulic delivery pipe (6) from the hydraulic pump.
3. Disconnect the bi-speed delivery pipe (2) from the hydraulic pump.
4. Remove the retaining screw (5), and then remove the oil cooler pipe (4).
5. Disconnect the suction hose (1).

Tightening torque	Bi-speed delivery pipe joint screw (Pump side)	34.3 to 39.2 N·m 3.5 to 4.0 kgf·m 25.3 to 28.9 lbf·ft
	Bi-speed delivery pipe retaining nut (Bi-speed valve side)	29 to 49 N·m 3.0 to 5.0 kgf·m 21.7 to 36.2 lbf·ft

- |                            |                                       |
|----------------------------|---------------------------------------|
| (1) Suction Hose           | (5) Retaining Screw                   |
| (2) Bi-speed Delivery Pipe | (6) <b>3P</b> Hydraulic Delivery Pipe |
| (3) Accelerator Wire       | (7) Retaining Screw                   |
| (4) Oil Cooler Pipe        |                                       |

9Y1211109ENS0059US0

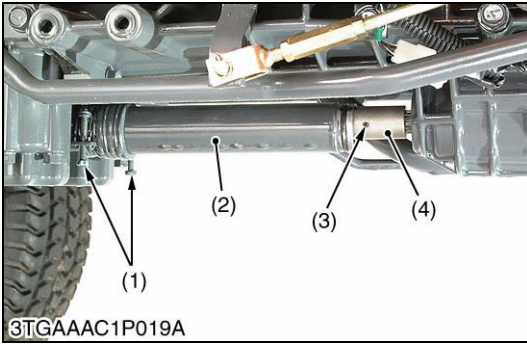

**Propeller Shaft**

1. Loosen the clamp screws (1) and slide the propeller shaft cover (2).
2. Tap out the spring pin (3) and then slide the coupling (4).
3. Remove the propeller shaft with the cover.

**(When reassembling)**

- Apply grease to the spline portion of the propeller shaft and couplings.
- When inserting the spring pins (3), face their splits in the direction parallel to the propeller shaft.
- Tighten the clamp screws (1) upward from the bottom side.

- |                           |                |
|---------------------------|----------------|
| (1) Clamp Screw           | (3) Spring Pin |
| (2) Propeller Shaft Cover | (4) Coupling   |

9Y1211109ENS0032US0

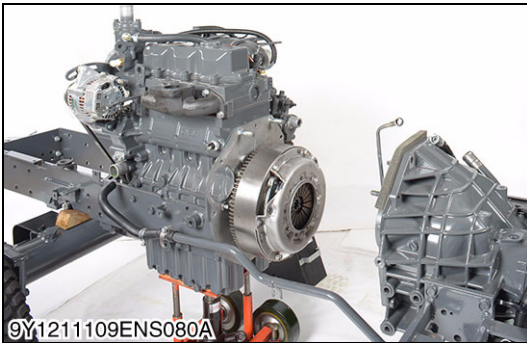

**Separating the Engine from Clutch Housing**

1. Place the disassembling stands under the clutch housing and engine oil pan.
2. Remove the starter.
3. Remove the engine mounting screws and nuts, and separate the engine from the clutch housing.

**(When reassembling)**

- Apply liquid gasket (Three Bond 1211 or equivalent) to joint face of the starter and rear end plate.
- Apply liquid gasket (Three Bond 1206C or equivalent) to joint face of the engine and clutch housing.

Tightening torque	Engine mounting screw and nut (M10)	48.1 to 55.9 N·m 4.9 to 5.7 kgf·m 35.5 to 41.2 lbf·ft
	Engine mounting nut (M12)	77.5 to 90.2 N·m 7.9 to 9.2 kgf·m 57.2 to 66.5 lbf·ft

9Y1211109ENS0060US0

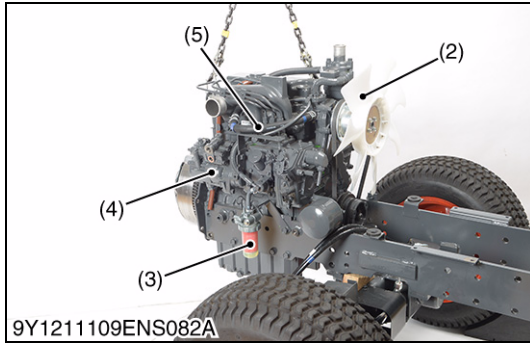
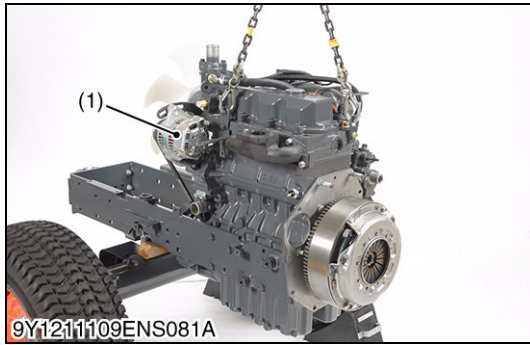
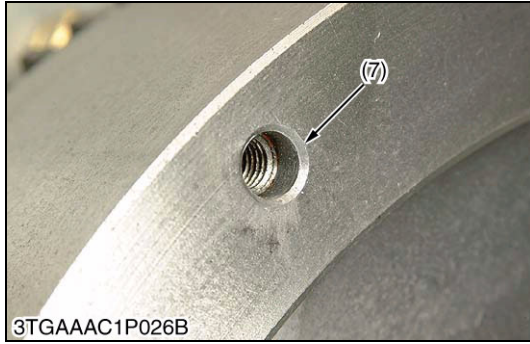
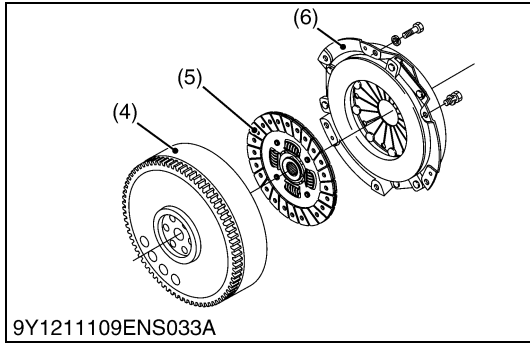
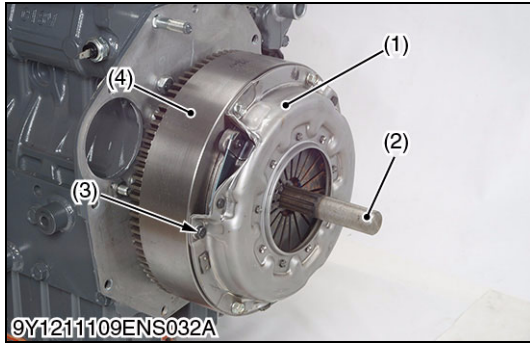

**Clutch Assembly**

1. Remove the clutch mounting screws and remove the clutch assembly (1) from the flywheel (4).

**(When reassembling)**

- Direct the shorter end of the clutch disc boss toward the flywheel (4).
- Apply molybdenum disulphide (Three Bond 1901 or equivalent) to the splines of clutch disc boss.
- Screws in two reamer screws (3) in the reamer screw holes (7).
- After tightening the reamer screws (3), tighten the other general screws.

**■ IMPORTANT**

- Align the center of clutch disc (5) and flywheel (4) by inserting the clutch center tool (2).

**■ NOTE**

- Do not allow grease and oil on the clutch disc facing.
- The reamer screw hole (7) on the clutch cover is in the next of the 5 mm (0.2 in.) dia. hole.
- The shape of the reamer screw hole (7) on the flywheel (4) is different from other screw holes.

Tightening torque	Clutch mounting screw	23.5 to 27.5 N·m 2.4 to 2.8 kgf·m 17.4 to 20.2 lbf·ft
-------------------	-----------------------	---

- |                        |                                 |
|------------------------|---------------------------------|
| (1) Clutch Assembly    | (5) Clutch Disc                 |
| (2) Clutch Center Tool | (6) Clutch Cover                |
| (3) Reamer Screw       | (7) Screw Hole for Reamer Screw |
| (4) Flywheel           |                                 |

9Y1211109ENS0034US0

**Separating Front Axle Assembly and Outer Parts**

1. Remove the fan (2).
2. Remove the alternator (1) with fan belt.
3. Disconnect the heater hoses (5).
4. Remove the fuel filter (3).
5. Remove the hydraulic pump (4) with regulator valve.
6. Remove the engine mounting screws and separate the front axle assembly from engine.

**(When reassembling)**

Tightening torque	Front axle frame mounting screw (M12)	78 to 90 N·m 7.9 to 9.2 kgf·m 58 to 66 lbf·ft
-------------------	---------------------------------------	---

- |                 |                    |
|-----------------|--------------------|
| (1) Alternator  | (4) Hydraulic Pump |
| (2) Fan         | (5) Heater Hose    |
| (3) Fuel Filter |                    |

9Y1211109ENS0062US0

### [3] DISASSEMBLING AND ASSEMBLING

#### (1) Cylinder Head and Valves

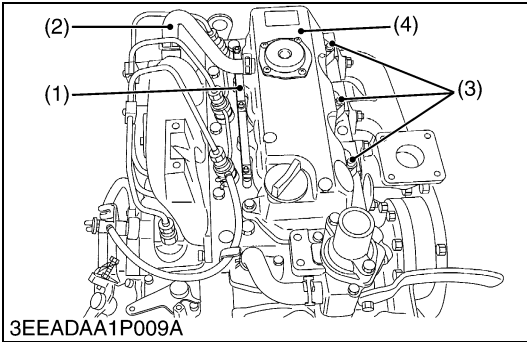

##### Cylinder Head Cover

1. Remove the lead (4).
2. Remove the breather hose (1).
3. Remove the head cover screws (3).
4. Remove the cylinder head cover (2).

##### **(When reassembling)**

- Check to see if the cylinder head cover gasket (5) is not damaged.

Tightening torque	Cylinder head cover screw	6.87 to 11.2 N·m 0.700 to 1.15 kgf·m 5.07 to 8.31 lbf·ft
-------------------	---------------------------	--

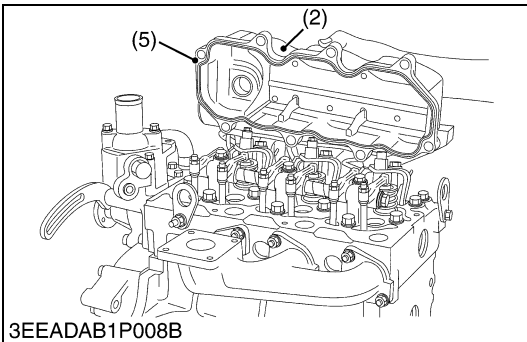

- |                         |                                |
|-------------------------|--------------------------------|
| (1) Breather Hose       | (5) Cylinder Head Cover Gasket |
| (2) Cylinder Head Cover | (6) Breather Valve             |
| (3) Head Cover Screw    | (7) Plate                      |
| (4) Lead                |                                |

9Y1211109ENS0063US0

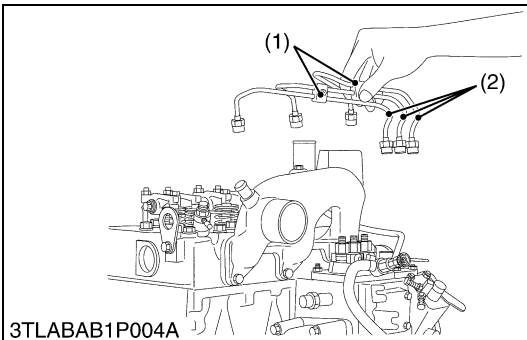
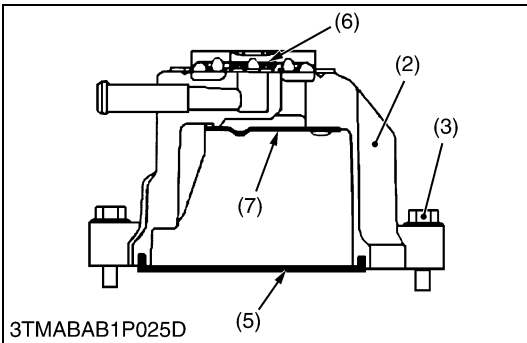

##### Injection Pipes

1. Loosen the screws on the pipe clamps (1).
2. Remove the injection pipes (2).

##### **(When reassembling)**

- Blow out dust inside the pipes.

Tightening torque	Injection pipe retaining nut	25 to 34 N·m 2.5 to 3.5 kgf·m 18 to 25 lbf·ft
-------------------	------------------------------	---

- |                |                    |
|----------------|--------------------|
| (1) Pipe Clamp | (2) Injection Pipe |
|----------------|--------------------|

9Y1211109ENS0064US0

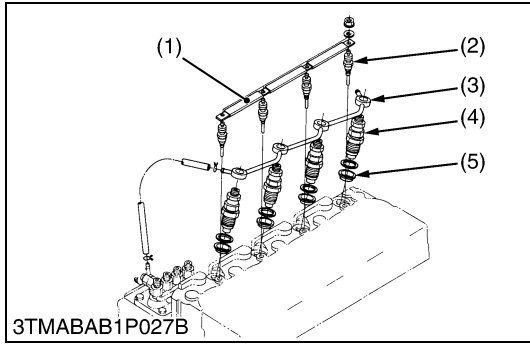

**Nozzle Holder Assembly and Glow Plug**

1. Remove the overflow pipe assembly (3).
2. Remove the nozzle holder assemblies (4) using a 21 mm deep socket wrench.
3. Remove the copper gasket and heat seal (5).
4. Remove the glow plugs (2).

**(When reassembling)**

- Replace the copper gasket and heat seal with new one.

Tightening torque	Nozzle holder assembly	49 to 68 N·m 5.0 to 7.0 kgf·m 37 to 50 lbf·ft
	Overflow pipe assembly retaining nut	20 to 24 N·m 2.0 to 2.5 kgf·m 15 to 18 lbf·ft
	Glow plug	20 to 24 N·m 2.0 to 2.5 kgf·m 15 to 18 lbf·ft

- (1) Lead (4) Nozzle Holder Assembly  
 (2) Glow Plug (5) Heat Seal  
 (3) Overflow Pipe Assembly

9Y1211109ENS0065US0

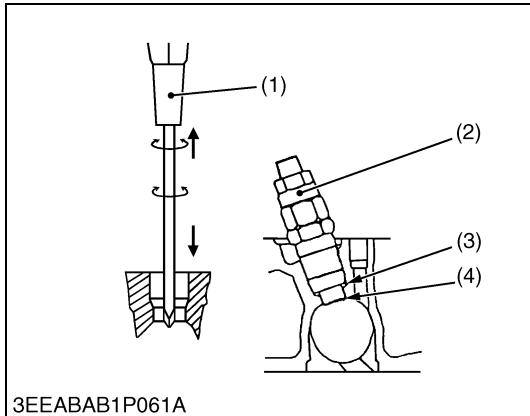

**Nozzle Heat Seal Service Removal Procedure**

**■ IMPORTANT**

- Use a plus (Phillips head) screw driver (1) that has a diameter which is bigger than the heat seal hole (Approx. 6 mm (1/4 in.)).

1. Drive screw driver (1) lightly into the heat seal hole.
2. Turn screw driver three or four times each way.
3. While turning the screw driver, slowly pull the heat seal (4) out together with the copper gasket (3).
4. If the heat seal drops, repeat the above procedure.

**(When reassembling)**

- Heat seal and copper gasket must be changed when the injection nozzle is removed for cleaning or for service.

- (1) Plus Screw Driver (3) Copper Gasket  
 (2) Nozzle Holder (4) Heat Seal

9Y1211109ENS0066US0

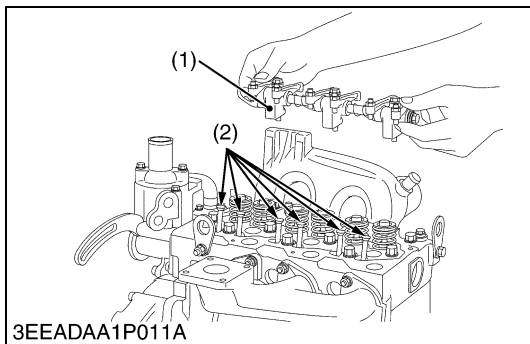

**Rocker Arm and Push Rod**

1. Remove the rocker arm bracket mounting bolts.
2. Remove the rocker arm assembly (1).
3. Remove the push rods (2).

**(When reassembling)**

- When putting the push rods (2) onto the tappets (3), check to see if their ends are properly engaged with the grooves.

**■ IMPORTANT**

- After installing the rocker arm, be sure to adjust the valve clearance.

Tightening torque	Rocker arm bracket screw	24 to 27 N·m 2.4 to 2.8 kgf·m 18 to 20 lbf·ft
-------------------	--------------------------	---

- (1) Rocker Arm Assembly (3) Tappet  
 (2) Push Rod

9Y1211109ENS0067US0

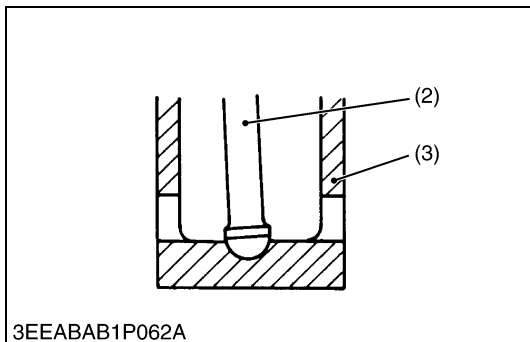

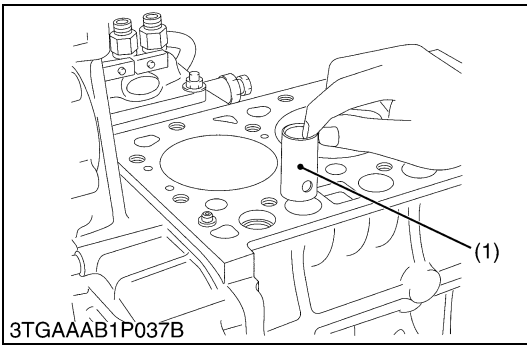
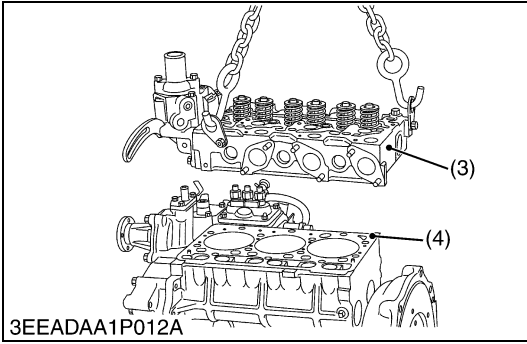
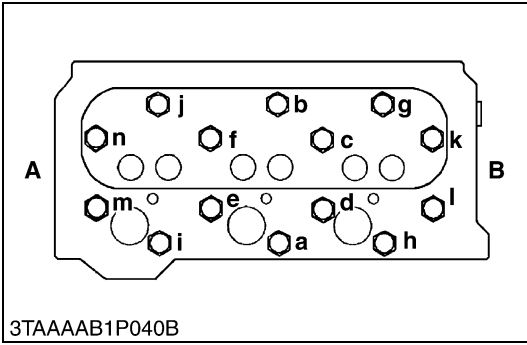
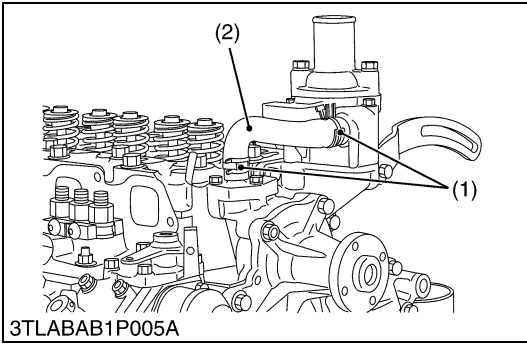

**Cylinder Head**

1. Loosen the pipe clamp (1), and remove the water return pipe (2).
2. Remove the cylinder head screw in the order of "n" to "a".
3. Lift up the cylinder head (3) to remove.
4. Remove the cylinder head gasket (4).

**(When reassembling)**

- Replace the cylinder head gasket (4) with a new one.
- Tighten the cylinder head screws after applying sufficient oil.
- Tighten the cylinder head screws in diagonal sequence starting from the center in the order of "a" to "n".
- Tighten them uniformly, or the head may deform in the long run.

Tightening torque	Cylinder head screw	93.2 to 98.0 N·m 9.50 to 10.0 kgf·m 68.8 to 72.3 lbf·ft
-------------------	---------------------	---

- (1) Pipe Clamp
- (2) Return Pipe
- (3) Cylinder Head
- (4) Cylinder Head Gasket

"n" to "a": To Loosen  
 "a" to "n": To Tighten  
**A: Gear Case Side**  
**B: Flywheel Side**

9Y1211109ENS0068US0

**Tappets**

1. Remove the tappets (1) from the crankcase.

**(When reassembling)**

- Visually check the contact between tappets and cams for proper rotation. If problem is found, replace tappets.
- Before installing the tappets, apply engine oil thinly around them.

■ **IMPORTANT**

- **Do not change the combination of tappet and tappet guide.**

- (1) Tappet

9Y1211109ENS0069US0



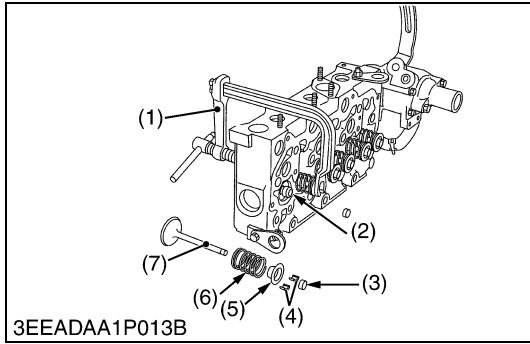

**Valves**

1. Remove the valve caps (3).
2. Remove the valve spring collet (4), pushing the valve spring retainer (5) by valve spring replacer (1).
3. Remove the valve spring retainer (5), valve spring (6) and valve stem seal (2).
4. Remove the valve (7).

**(When reassembling)**

- Wash the valve stem and valve guide hole, and apply engine oil sufficiently.
- After installing the valve spring collets (4), lightly tap the stem to assure proper fit with a plastic hammer.

**■ IMPORTANT**

- **Do not change the combination of valve and valve guide.**

- |                           |                           |
|---------------------------|---------------------------|
| (1) Valve Spring Replacer | (5) Valve Spring Retainer |
| (2) Valve Stem Seal       | (6) Valve Spring          |
| (3) Valve Cap             | (7) Valve                 |
| (4) Valve Spring Collet   |                           |

9Y1211109ENS0070US0

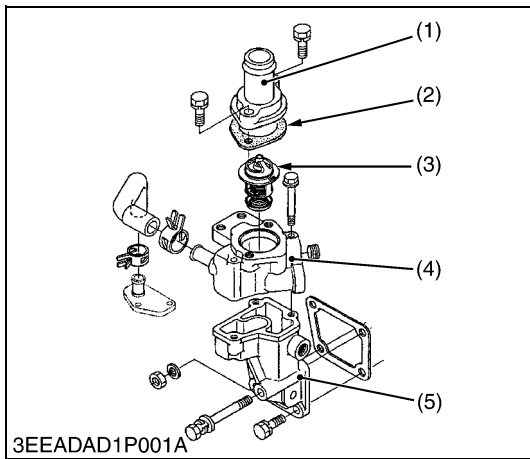

**Thermostat Assembly**

1. Remove the thermostat cover mounting screws, and remove the thermostat cover (1).
2. Remove the thermostat assembly (3).

**(When reassembling)**

- Apply a liquid gasket (Three Bond 1217H or equivalent) to the water flange 1 (4) and flange 2 (5).

- |                             |                    |
|-----------------------------|--------------------|
| (1) Thermostat Cover        | (4) Water Flange 1 |
| (2) Thermostat Cover Gasket | (5) Water Flange 2 |
| (3) Thermostat Assembly     |                    |

9Y1211109ENS0071US0

## (2) Timing Gears, Camshaft and Fuel Camshaft

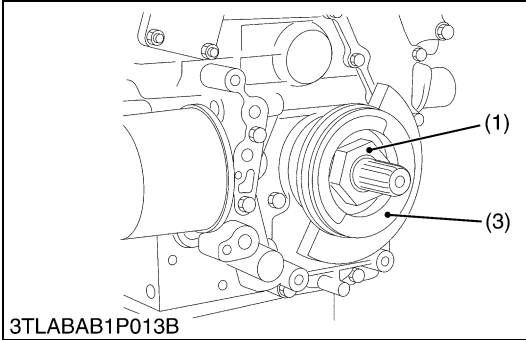
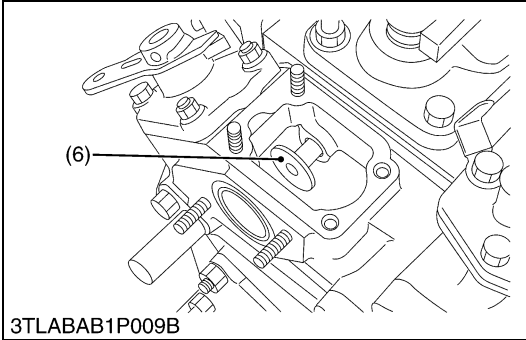
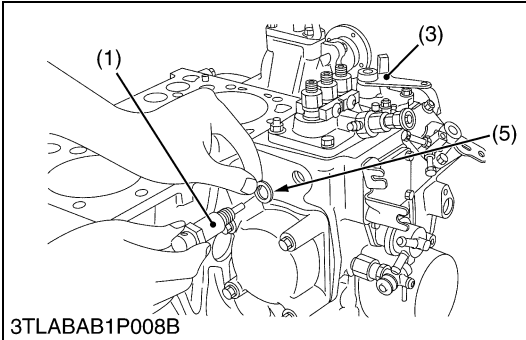
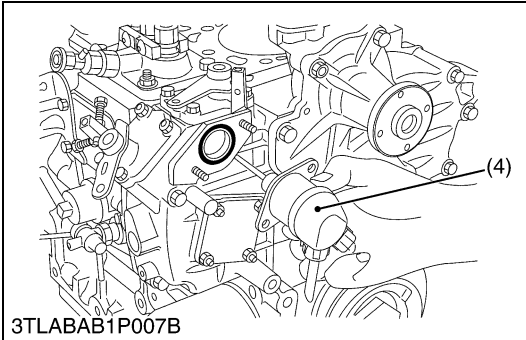
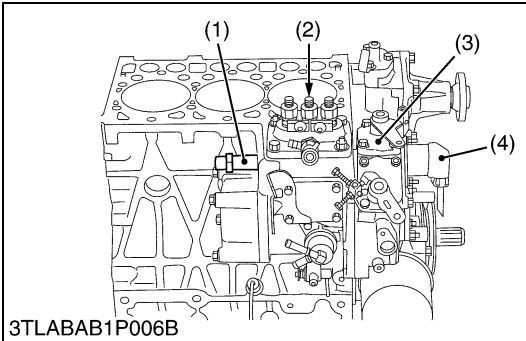

### Injection Pump

1. Remove the stop solenoid (4) and hi-idling body (1).
2. Remove the engine stop lever (3) and stop solenoid guide (6).
3. Remove the fuel injection pump assembly (2).

#### ■ IMPORTANT

- Before removing the injection pump assembly (2), be sure to remove the stop solenoid (4), hi-idling body (1), engine stop lever (3) and stop solenoid guide (6).

#### (When reassembling)

- Before attaching the stop solenoid (4), hi-idling body (1) and stop solenoid guide (6), install the injection pump first into position.
- Replace the hi-idling body gasket (5) with a new one.
- Before fitting the stop lever (3) to the gear case, install the stop solenoid guide (6) first into position. Then attach the stop lever and use it to see if it functions well.
- Before fitting the idling limiter in place, attach the stop solenoid guide (6) and the engine stop lever (3) in their respective positions.
- When installing the stop solenoid (4), be careful to keep the O-ring in place.
- Be sure to insert the push rod of the stop solenoid into the hole at the center of the solenoid guide (6).

Tightening torque	Hi-idling body	45 to 49 N·m 4.5 to 5.0 kgf·m 33 to 36 lbf·ft
-------------------	----------------	---

- |                             |                           |
|-----------------------------|---------------------------|
| (1) Hi-idling Body          | (4) Stop Solenoid         |
| (2) Injection Pump Assembly | (5) Hi-idling Body Gasket |
| (3) Stop Lever              | (6) Stop Solenoid Guide   |

9Y1211109ENS0072US0

**Governor Springs and Speed Control Plate**

■ **NOTE**

- **Specific tool (1):**  
**1.2 mm diameter hard wire with its end hooked, overall length 200 mm (7.87 in.).**  
**The tip of wire is bent like the hook to hang governor springs.**

1. Remove the injection pump cover.
2. Remove the speed control plate (6) mounting nuts and bolts.
3. Using the specific tool (1), undo the large governor spring (3) from the fork lever (2).
4. Using the specific tool (1), undo the small governor spring (4) from the fork lever (2).
5. Set the speed control lever (5) as shown in the figure.
6. Remove the speed control plate (6) with care not to let the large (3) and small (4) governor springs come off this plate and fall in to the gear case.

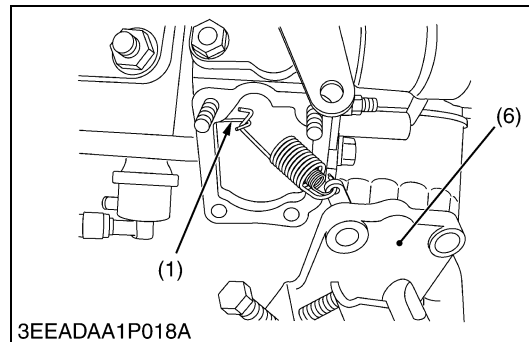
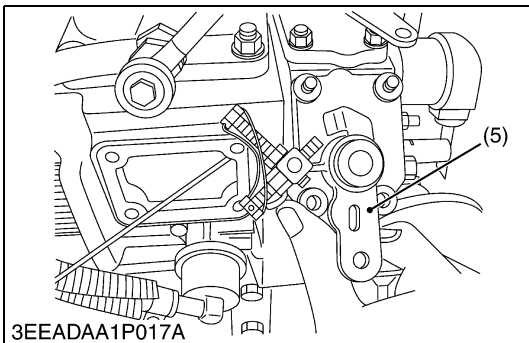
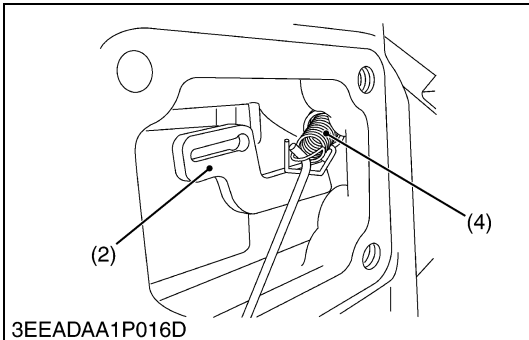
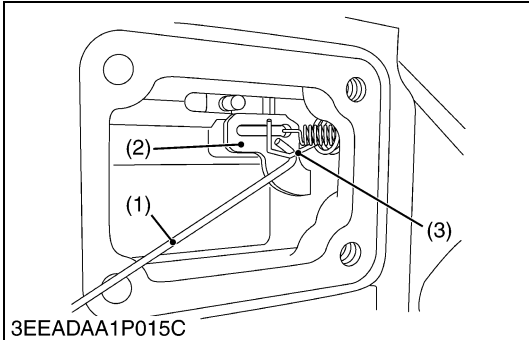
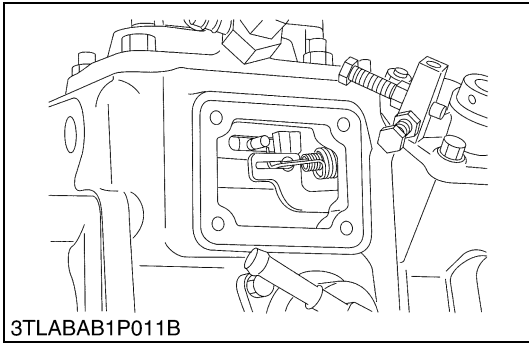
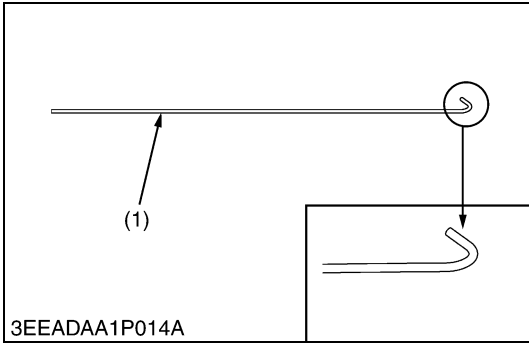

- |                           |                           |
|---------------------------|---------------------------|
| (1) Specific Tool         | (4) Small Governor Spring |
| (2) Fork Lever            | (5) Speed Control Lever   |
| (3) Large Governor Spring | (6) Speed Control Plate   |

**(To be continued)**

(Continued)

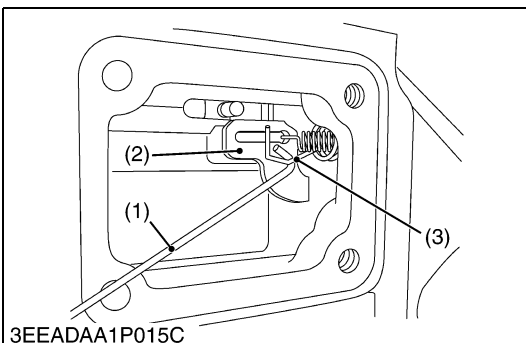
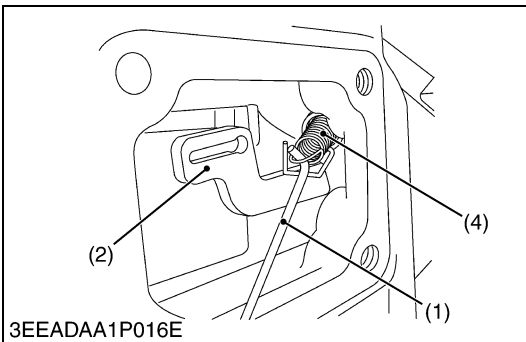
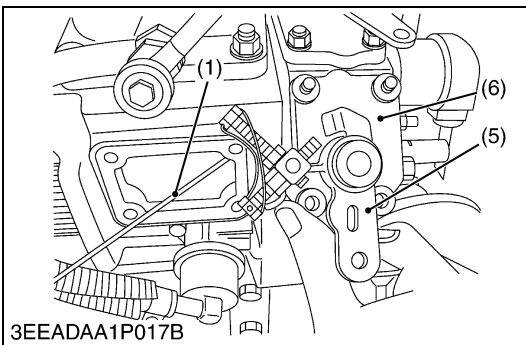
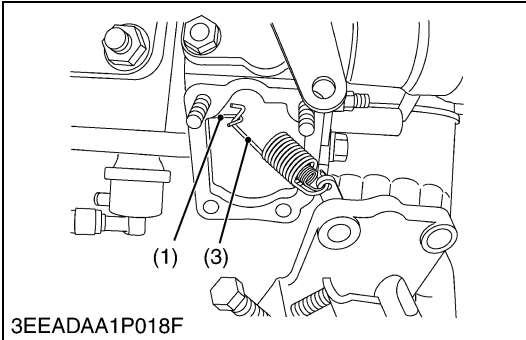
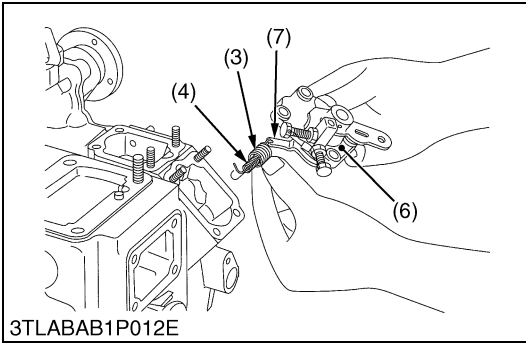

**(When reassembling)**

- Set the end with less clearance (color painted (8) when it is new) of small governor spring (4) to the governor lever (7).
- Set the large governor spring (3) to the governor lever (7).
- Put the specific tool (1) from the injection pump cover side to catch the large governor spring (3). Keep this spring in an extended position and put the speed control plate (6) in its specified position.
- Use the specific tool (1), set the small governor spring (4) on the fork lever (2).
- Use the specific tool (1), set the large governor spring (3) on the fork lever (2).

■ **NOTE**

- **Be careful not to stretch the small governor spring (4) too long because otherwise it may get deformed permanently.**
- **Make sure both the governor springs (3), (4) are tight on the fork lever (2).**
- **Apply and tighten up the two bolts and two nuts on the speed control plate (6).**
- **Check that the speed control lever (5) positions low idle, after assembling governor springs.**
- **Check that the speed control lever (5) returns to the high idle position rather than the low idle position, after moving the lever to the maximum speed position.**
- **Finally attach the injection pump cover in position.**

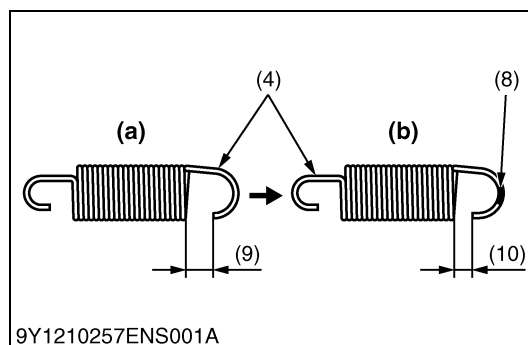
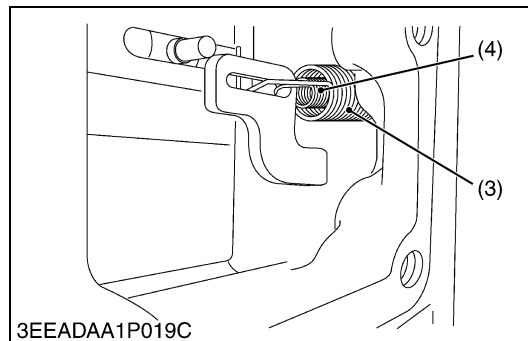

- |                           |                      |
|---------------------------|----------------------|
| (1) Specific Tool         | (7) Governor Lever   |
| (2) Fork Lever            | (8) Color Painted    |
| (3) Large Governor Spring | (9) 3 mm (0.1 in.)   |
| (4) Small Governor Spring | (10) 2 mm (0.08 in.) |
| (5) Speed Control Lever   | (a) Previous         |
| (6) Speed Control Plate   | (b) Modified         |

9Y1211109ENS0073US0

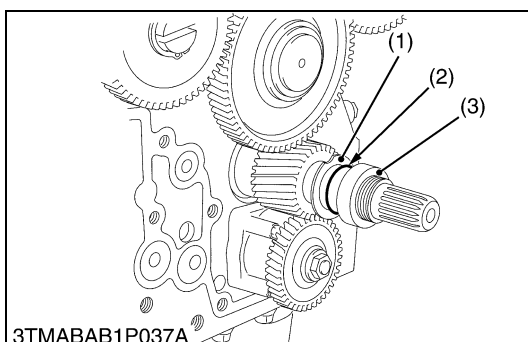
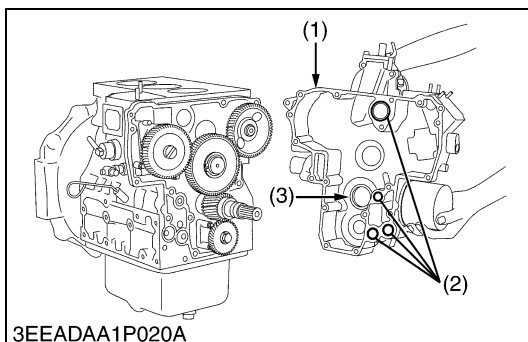
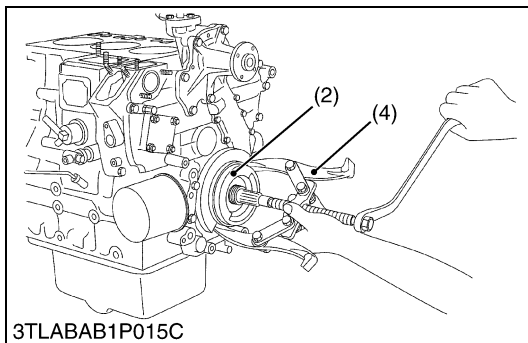
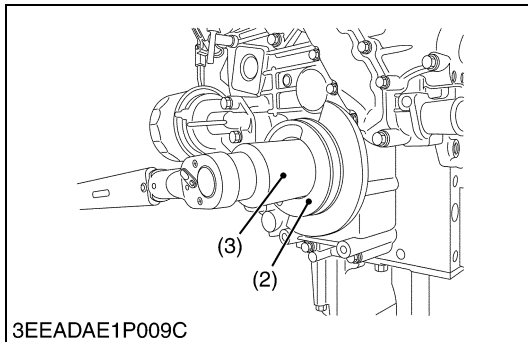
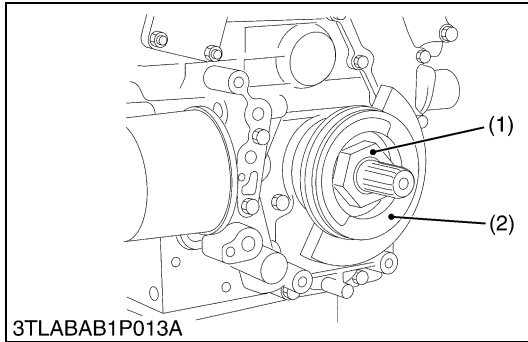

### Fan Drive Pulley

1. Lock the flywheel not to turn using the flywheel stopper.
2. Remove the fan drive pulley mounting nut (1) using 46 mm deep socket wrench (3).
3. Remove the fan drive pulley (2) with gear puller (4).
4. Remove the feather key.

#### (When reassembling)

- Apply grease to the splines of coupling.

Tightening torque	Fan drive pulley mounting nut	138 to 156 N·m 14.0 to 16.0 kgf·m 102 to 115 lbf·ft
-------------------	-------------------------------	---

- (1) Nut (3) 46 mm Deep Socket Wrench  
(2) Fan Drive Pulley (4) Gear Puller

9Y1211109ENS0074US0

### Gear Case

1. Remove the hour meter gear case (if equipped).
2. Remove the gear case (1).
3. Remove the O-rings (2).

#### (When reassembling)

- Apply liquid gasket (Three Bond 1215 or equivalent) to both sides of hour meter gear case gasket.
- Check to see if there are four O-rings (2) inside the gear case (1).
- Apply a thin film of engine oil to the oil seal (3), and install it, noting the lip come off.
- Before installing the gear case gasket, apply a non-drying adhesive.

- (1) Gear Case (3) Oil Seal  
(2) O-ring

9Y1211109ENS0075US0

### Crankshaft Oil Slinger

1. Remove the crankshaft collar (3).
2. Remove the O-ring (2).
3. Remove the crankshaft oil slinger (1).

#### (When reassembling)

- Insert the crankshaft collar (3) after install the gear case to cylinder body.

- (1) Crankshaft Oil Slinger (3) Crankshaft Collar  
(2) O-ring

9Y1211109ENS0076US0

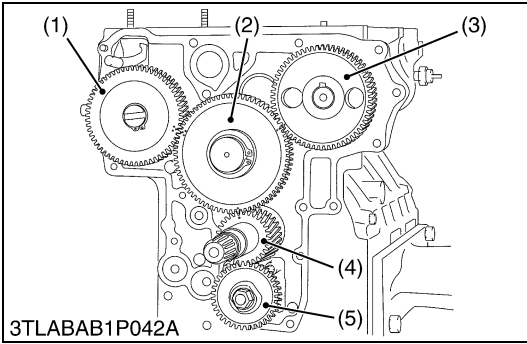

**Idle Gear**

1. Remove the external snap ring.
2. Remove the idle gear collar.
3. Remove the idle gear (2).

**(When reassembling)**

- Check to see each gear is aligned with its aligning mark.
  - Idle gear (2) and crank gear (4)
  - Idle gear (2) and camshaft gear (3)
  - Idle gear (2) and injection pump gear (1)

- |                         |                         |
|-------------------------|-------------------------|
| (1) Injection Pump Gear | (4) Crank Gear          |
| (2) Idle Gear           | (5) Oil Pump Drive Gear |
| (3) Camshaft Gear       |                         |

9Y1211109ENS0077US0

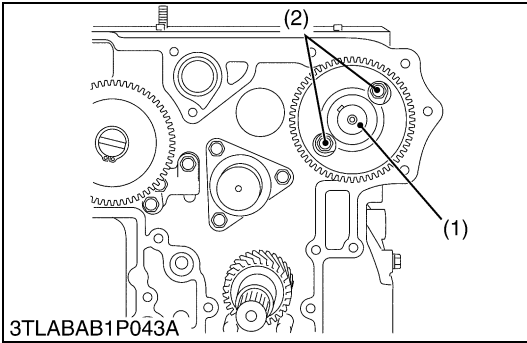

**Camshaft**

1. Remove the camshaft set screws (2) and draw out the camshaft (1).

**(When reassembling)**

- When installing the idle gear, be sure to align the alignment marks on gears.

Tightening torque	Camshaft set screw	24 to 27 N·m 2.4 to 2.8 kgf·m 18 to 20 lbf·ft
-------------------	--------------------	---

- |              |                        |
|--------------|------------------------|
| (1) Camshaft | (2) Camshaft Set Screw |
|--------------|------------------------|

9Y1211109ENS0078US0

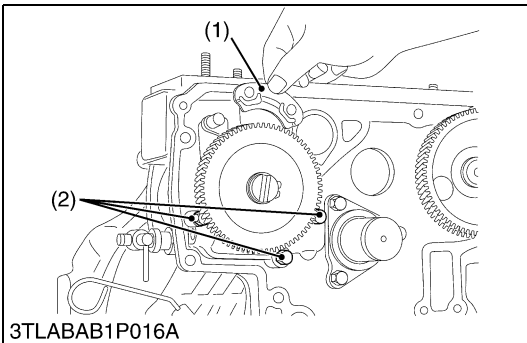

**Fuel Camshaft and Fork Lever Assembly**

1. Remove the fuel feed pump.
2. Remove the fuel camshaft stopper (1).
3. Remove the three fork lever holder mounting screws (2).
4. Draw out the fuel camshaft assembly (5), (6) and fork lever assembly (3), (4), (7) at the same time.

**(When reassembling)**

- After installation, check to see that the fork lever 1 (3) and lever 2 (4) are fixed to the fork lever shaft, and that they can turn smoothly in the holder (7).

- |                                      |                         |
|--------------------------------------|-------------------------|
| (1) Fuel Camshaft Stopper            | (5) Injection Pump Gear |
| (2) Fork Lever Holder Mounting Screw | (6) Fuel Camshaft       |
| (3) Fork Lever 1                     | (7) Fork Lever Holder   |
| (4) Fork Lever 2                     |                         |

9Y1211109ENS0079US0

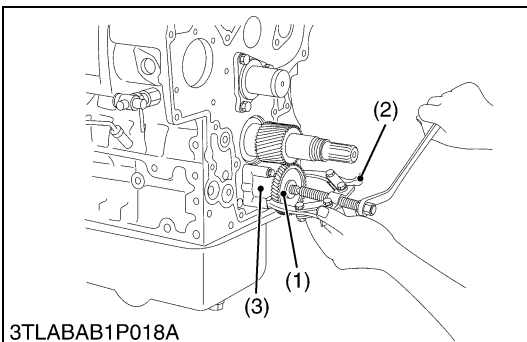
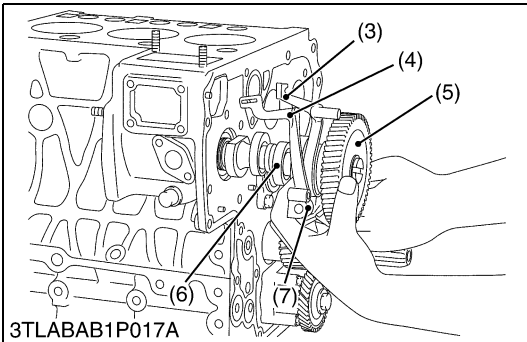

**Oil Pump**

1. Remove the nut.
2. Draw out the oil pump drive gear (1) with gear puller (2).
3. Remove the four oil pump mounting screws. Remove the oil pump (3).

- |                         |              |
|-------------------------|--------------|
| (1) Oil Pump Drive Gear | (3) Oil Pump |
| (2) Gear Puller         |              |

9Y1211109ENS0080US0

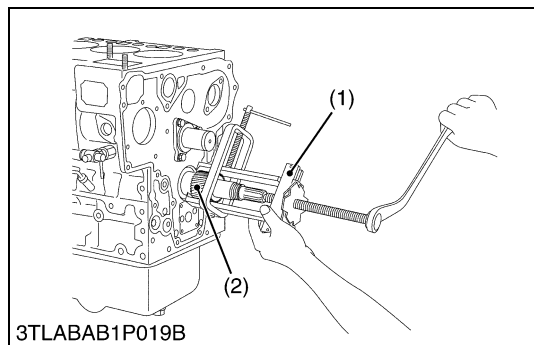

### Crank Gear

1. Draw out the crank gear (2) with a puller (1).
2. Remove the feather key.

(1) Crank Puller

(2) Crank Gear

9Y1211109ENS0081US0

## (3) Piston and Connecting Rod

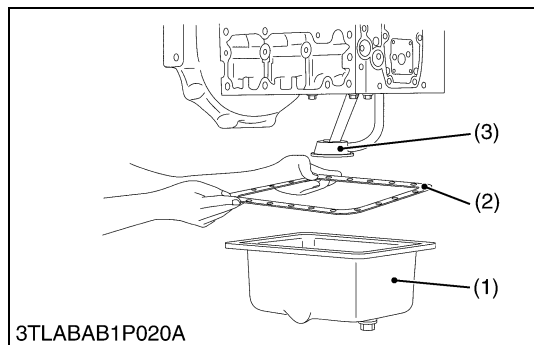

### Oil Pan and Oil Strainer

1. Remove the oil pan mounting screws.
2. Remove the oil pan (1) by lightly tapping the rim of the pan with a wooden hammer.
3. Remove the oil pan gasket (2).
4. Remove the oil strainer (3) and O-ring (4).

#### **(When reassembling)**

- After cleaning the oil strainer (3), check to see that the filter mesh is clean, and install it.
- Visually check the O-ring (4), apply engine oil, and install it.
- Securely fit the O-ring (4) to the oil strainer (3).
- Apply a liquid gasket (Three Bond 1217H or equivalent) to the oil pan side of the oil pan gasket (2).
- To avoid uneven tightening, tighten oil pan mounting screws in diagonal order from the center.

(1) Oil Pan

(3) Oil Strainer

(2) Oil Pan Gasket

(4) O-ring

9Y1211109ENS0082US0

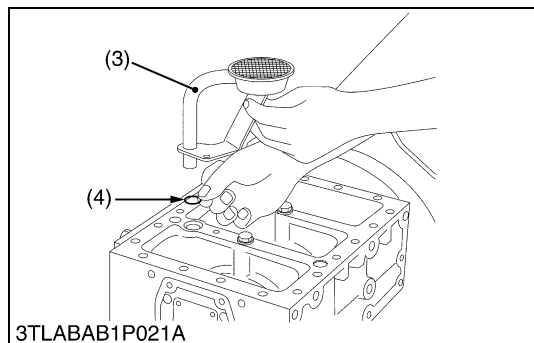

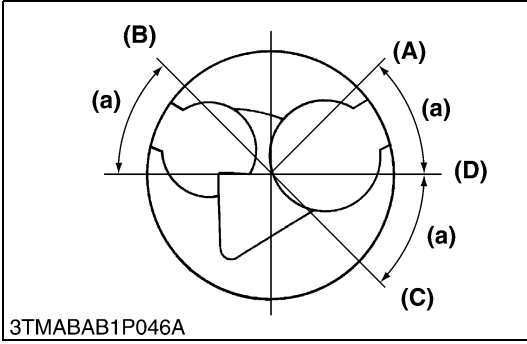
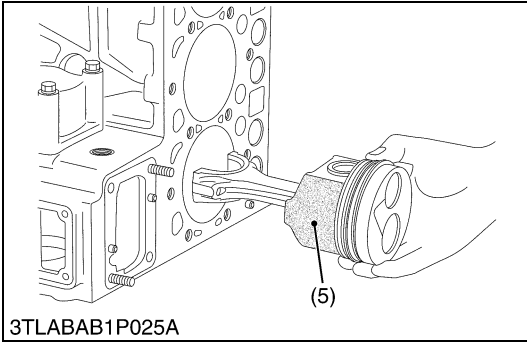
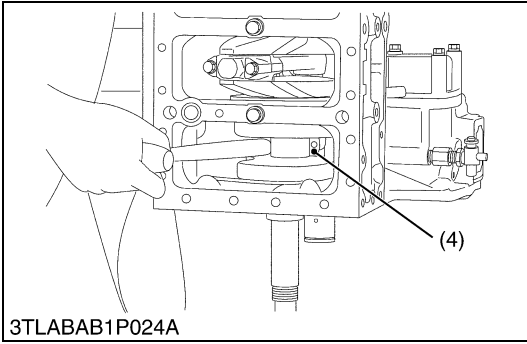
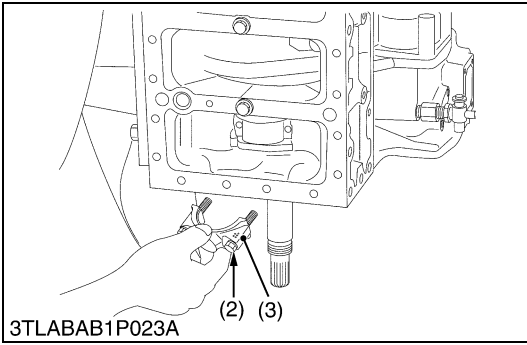
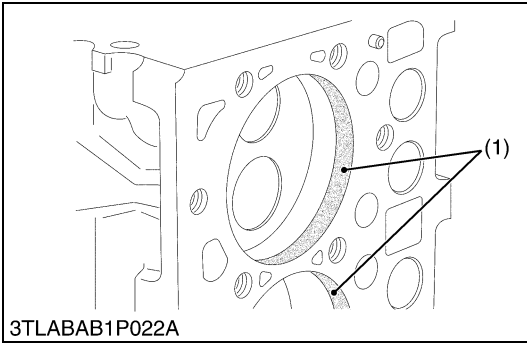

**Pistons**

1. Completely clean carbon (1) in the cylinders.
2. Remove the connecting rod cap (3).
3. Turn the flywheel and bring the piston to top dead center.
4. Draw out the piston upward by lightly tapping it from the bottom of the crankcase with the grip of a hammer.
5. Draw out the other piston in the same method as above.

**(When reassembling)**

- Before inserting piston into the cylinder, apply enough engine oil to the piston.
- When inserting the piston into the cylinder, face the mark on the connecting rod to the injection pump.

**■ IMPORTANT**

- **Do not change the combination of cylinder and piston. Make sure of the position of each piston by marking. For example, mark "1" on the No. 1 piston.**
- **Place the piston rings with their gaps at 0.79 rad (45 °) from the piston pin's direction as shown in the figure.**
- **Carefully insert the pistons using a piston ring compressor (6).**
- **When inserting the piston in place, be careful not to get the molybdenum disulfide coating torn off its skirt. This coating is useful in minimizing the clearance with the cylinder liner. Just after the piston pin has been press-fitted, in particular, the piston is still hot and the coating is easy to peel off. Wait until the piston cools down.**

Tightening torque	Connecting rod screw	41 to 45 N·m 4.1 to 4.6 kgf·m 30 to 33 lbf·ft
-------------------	----------------------	---

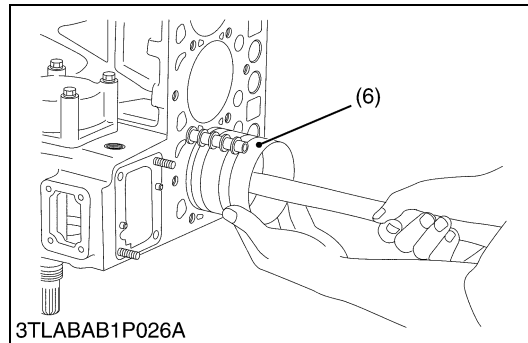

- |  |  |
|--|--|
| <ul style="list-style-type: none"> <li>(1) Carbon</li> <li>(2) Connecting Rod Screw</li> <li>(3) Connecting Rod Cap</li> <li>(4) Connecting Rod</li> <li>(5) Molybdenum Disulfide Coating in Piston Skirt</li> <li>(6) Piston Ring Compressor</li> </ul> | <ul style="list-style-type: none"> <li><b>(A) Top Ring Gap</b></li> <li><b>(B) Second Ring Gap</b></li> <li><b>(C) Oil Ring Gap</b></li> <li><b>(D) Piston Pin Hole</b></li> <li><b>(a) 0.79 rad (45 °)</b></li> </ul> |
|--|--|

9Y1211109ENS0083US0



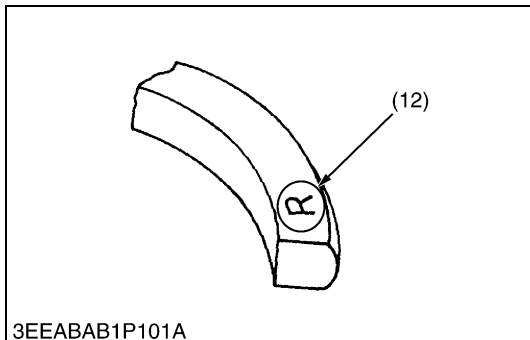
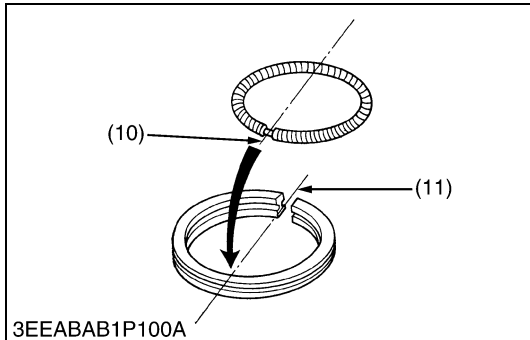
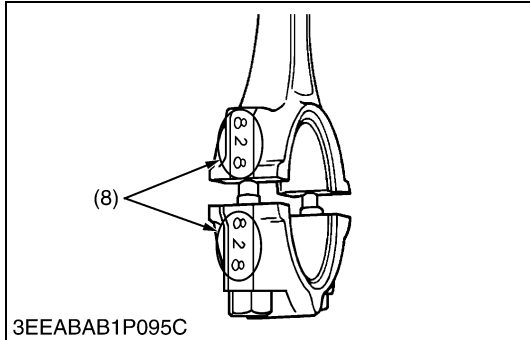
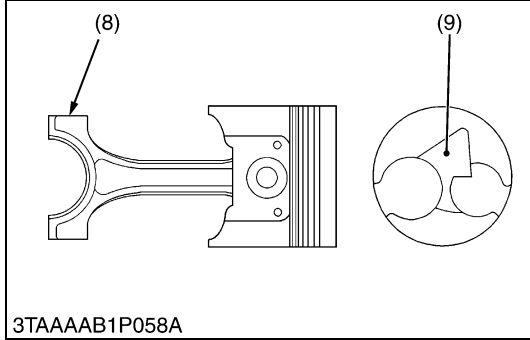
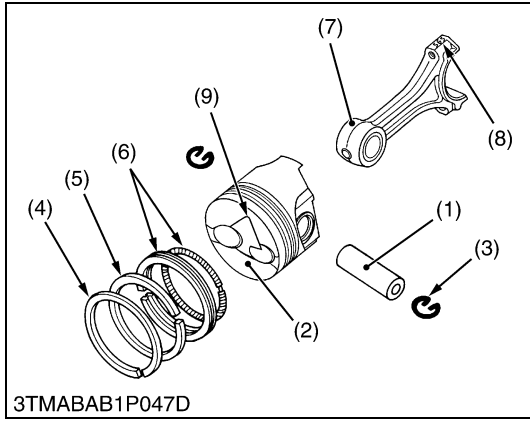

**Piston Ring and Connecting Rod**

1. Remove the piston rings (4), (5), (6) using a piston ring tool (Code No. 07909-32121).
2. Remove the piston pin (1), and separate the connecting rod (7) from the piston (2).

**(When reassembling)**

- When installing the rings, assemble the rings so that the manufacturer's mark (12) near the gap faces the top of the piston (2).
- When installing the oil ring (6) onto the piston (2), place the expander joint (10) on the opposite side of the oil ring gap (11).
- Apply engine oil to the piston pin.
- When installing the piston pin (1), immerse the piston (2) in 80 °C (176 °F) oil for 10 to 15 minutes and insert the piston pin (1) to the piston (2).
- When installing the connecting rod (7) to the piston (2), align the mark (8) on the connecting rod (7) to the fan-shaped concave (9).

■ **NOTE**

- **Mark the same number on the connecting rod (7) and the piston (2) so as not to change the combination.**

- |                          |                          |
|--------------------------|--------------------------|
| (1) Piston Pin           | (7) Connecting Rod       |
| (2) Piston               | (8) Mark                 |
| (3) Piston Pin Snap Ring | (9) Fan-Shaped Concave   |
| (4) Top Ring             | (10) Expander Joint      |
| (5) Second Ring          | (11) Oil Ring Gap        |
| (6) Oil Ring             | (12) Manufacturer's Mark |

9Y1211109ENS0084US0

### (4) Crankshaft

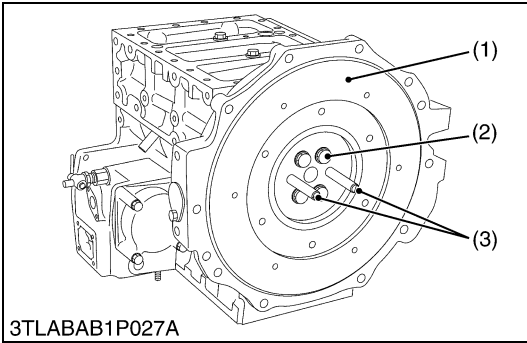

#### Flywheel

1. Fit the stopper to the flywheel (1).
2. At first, remove two pieces of the flywheel screws (2).
3. Insert two pieces of the flywheel guide screws (3) in the holes.
4. Remove the all flywheel screws (2).
5. Remove the flywheel (1) slowly along the flywheel guide screws (3).

#### (When reassembling)

- Insert two pieces of the flywheel guide screws.
- Check to see that there are no metal particles left on the flywheel mounting surfaces.
- Apply engine oil to the threads and the undercut surface of the flywheel bolt and fit the bolt.

Tightening torque	Flywheel screws	98.1 to 107 N·m 10.0 to 11.0 kgf·m 72.4 to 79.5 lbf·ft
-------------------	-----------------	--

- (1) Flywheel (3) Flywheel Guide Screw  
(2) Flywheel Screw

9Y1211109ENS0085US0

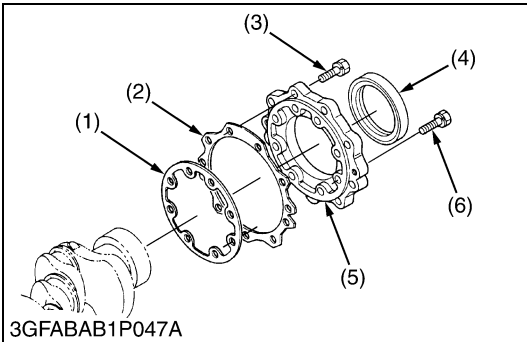

#### Bearing Case Cover

1. Remove the bearing case cover mounting screws. First, remove inside screws (6) and then outside screws (3).
2. Screw two removed screws into the screw hole of bearing case cover (5) to remove it.

#### ■ IMPORTANT

- The length of inside screws (6) and outside screws (3) are different. Do not take a mistake using inside screws and outside screws.

#### (When reassembling)

- Fit the bearing case gasket (1) and the bearing case cover gasket (2) with correct directions.
- Install the bearing case cover (5) to position the casting mark "UP" on it upward.
- Apply engine oil to the oil seal lip and be careful that it is not rolled when installing.
- Tighten the bearing case cover mounting screws with even force on the diagonal line.

Tightening torque	Bearing case cover mounting screw	24 to 27 N·m 2.4 to 2.8 kgf·m 18 to 20 lbf·ft
-------------------	-----------------------------------	---

- (1) Bearing Case Gasket (5) Bearing Case Cover  
(2) Bearing Case Cover Gasket (6) Bearing Case Cover Mounting Screw  
(3) Bearing Case Cover Mounting Screw  
(4) Oil Seal (a) Upside

9Y1211109ENS0086US0

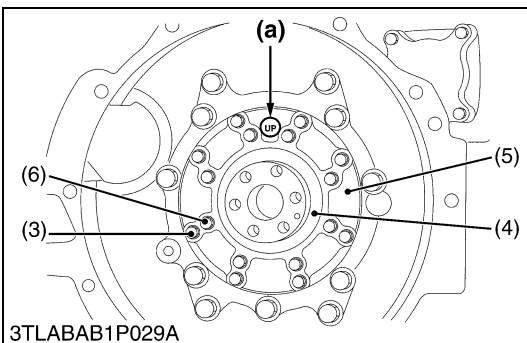
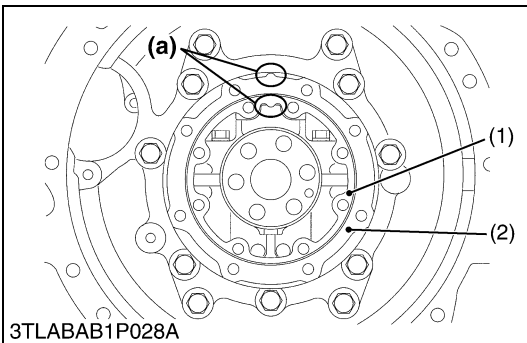

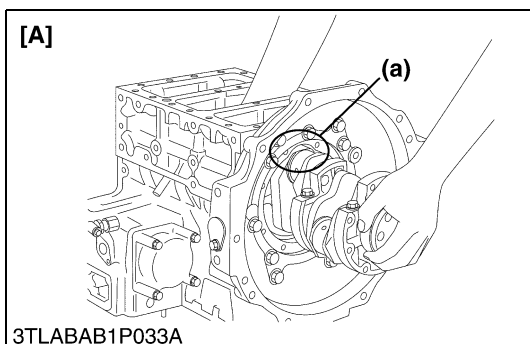
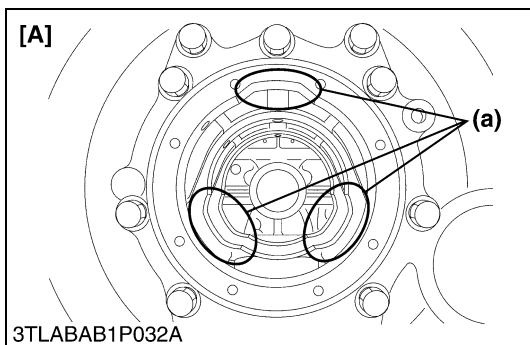
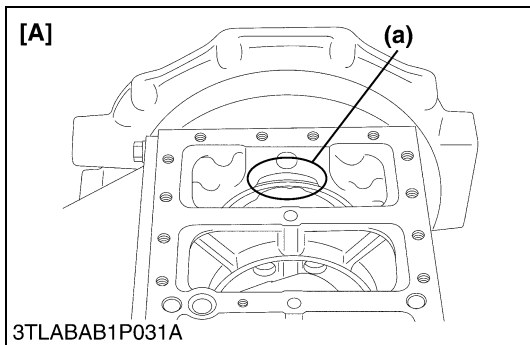
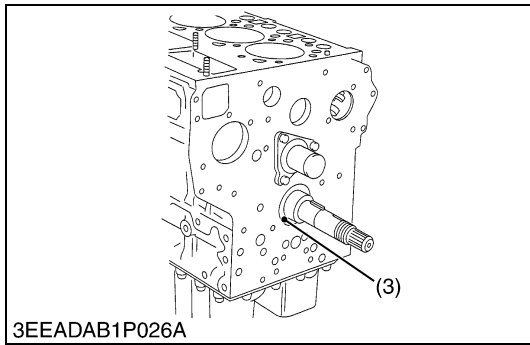
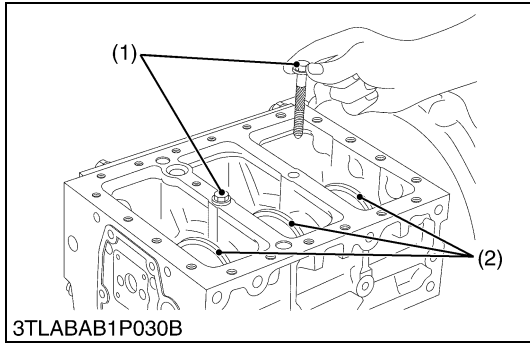

**Crankshaft**

■ **NOTE**

- Before disassembling, check the side clearance of crankshaft. Also check it during reassembling.

**For D1703-M**

1. Remove the main bearing case screw 2 (1).
2. Pull out the crankshaft assembly, taking care not to damage the crankshaft bearing 1 (3).

**For D1803-M**

1. Remove the main bearing case screw 2 (1).
2. Turn the crankshaft to set the crank pin of the third cylinder to the bottom dead center. Then draw out the crankshaft until the crank pin of the second cylinder comes to the center of the third cylinder.
3. Turn the crankshaft by 2.09 rad (120 °) counterclockwise to set the crank pin of the second cylinder to the bottom dead center. Draw out the crankshaft until the crank pin of the first cylinder comes to the center of the third cylinder.
4. Repeat the above steps to draw out all the crankshaft.

**(When reassembling)**

■ **IMPORTANT**

- Install the crankshaft sub assembly, aligning the screw hole of main bearing case 2 (2) with the screw hole of cylinder block.
- When tightening the main bearing case screw 2 (1), apply oil to the screw and screw by hand before tightening the specific torque.  
If not smooth to screw by hand, align the screw holes between the cylinder block and the main bearing case.

Tightening torque	Main bearing case screws	69 to 73 N·m
	2	7.0 to 7.5 kgf·m 51 to 54 lbf·ft

- (1) Main Bearing Case Screw 2
- (2) Main Bearing Case 2
- (3) Crankshaft Bearing 1

- (a) Cut place for removing and installing the crankshaft
- [A] D1803-M

9Y1211109ENS0087US0

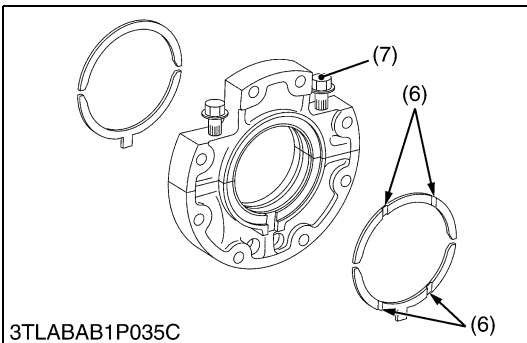
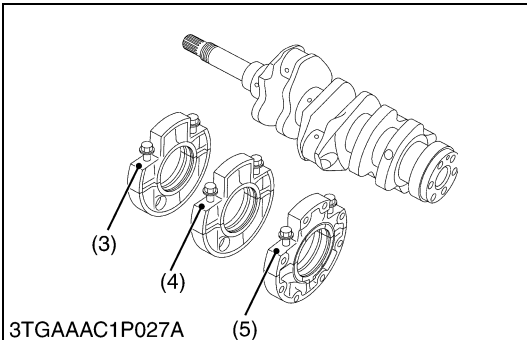
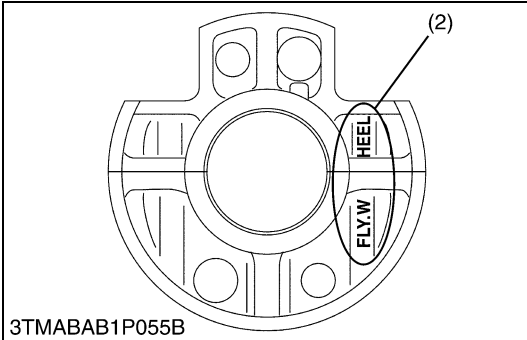
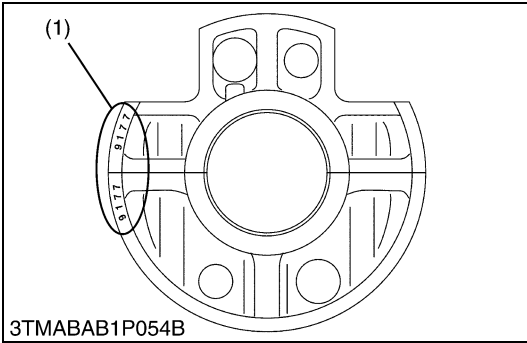
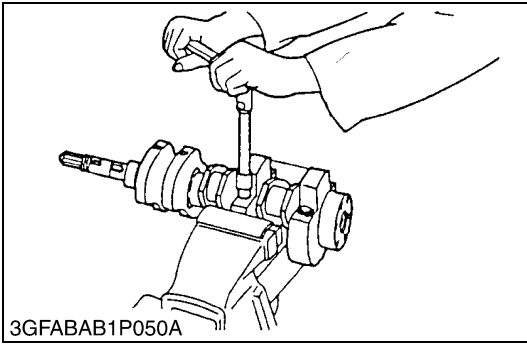

**Main Bearing Case Assembly**

1. Remove the two main bearing case screws 1 (7), and remove the main bearing case assembly being careful with thrust bearing and crankshaft bearing.
2. Remove the main bearing case 1, 2 as above.

**(When reassembling)**

- Clean the oil passage in the main bearing case.
- Apply clean engine oil on the bearings.
- Install the main bearing case assemblies in the original positions. Since diameters of main bearing cases vary, install them in order of makings (A, B) from the gear case side.
- Match the alignment numbers (1) and mark (2) on the main bearing case.
- When installing the main bearing case 1 and 2, face the mark "FLYWHEEL" to the flywheel.
- Install the thrust bearing with its oil groove (6) facing outward.
- Make sure that the main bearing case moves smoothly after tightening the main bearing case screw 1 (7) to the specified torque.

Tightening torque	Main bearing case screw 1	46 to 50 N·m
		4.7 to 5.2 kgf·m
		34 to 37 lbf·ft

- |                      |                               |
|----------------------|-------------------------------|
| (1) Alignment Number | (5) No Mark                   |
| (2) Alignment Mark   | (6) Oil Groove                |
| (3) A                | (7) Main Bearing Case Screw 1 |
| (4) B                |                               |

9Y1211109ENS0088US0

## (5) Thermostat and Water Pump

### CAUTION

- When removing the radiator cap, wait at least ten minutes after the engine has stopped and cooled down. Otherwise, hot water may gush out, scalding nearby people.

9Y1211109ENS0089US0

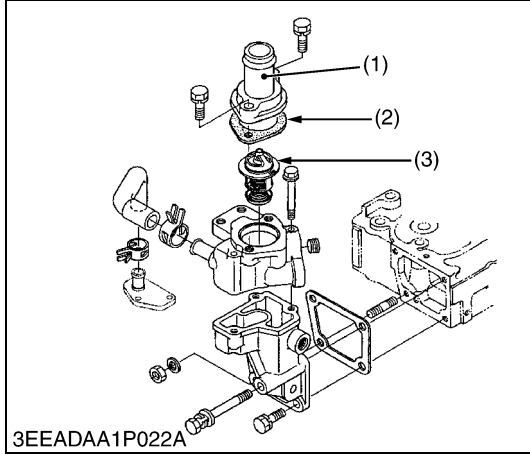

### Thermostat Assembly

- Remove the thermostat cover mounting screws, and remove the thermostat cover (1).
- Remove the thermostat assembly (3).

- |                             |                         |
|-----------------------------|-------------------------|
| (1) Thermostat Cover        | (3) Thermostat Assembly |
| (2) Thermostat Cover Gasket |                         |

9Y1211109ENS0090US0

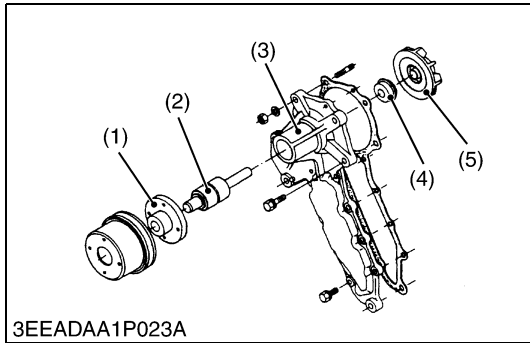

### Water Pump Assembly

- Loosen the alternator mounting bolts, and remove the fan belt.
- Remove the fan and fan pulley.
- Remove the water pump assembly from the gear case cover.
- Remove the water pump flange (1).
- Press out the water pump shaft (2) with the impeller (5) on it.
- Remove the impeller from the water pump shaft (2).
- Remove the mechanical seal (4).

#### **(When reassembling)**

- Apply a liquid gasket (Three Bond 1217H or equivalent) to the both sides of gasket.
- Replace the mechanical seal with new one.

- |                       |                     |
|-----------------------|---------------------|
| (1) Water Pump Flange | (4) Mechanical Seal |
| (2) Water Pump Shaft  | (5) Impeller        |
| (3) Water Pump Body   |                     |

9Y1211109ENS0091US0

# [4] SERVICING

## (1) Cylinder Head and Valves

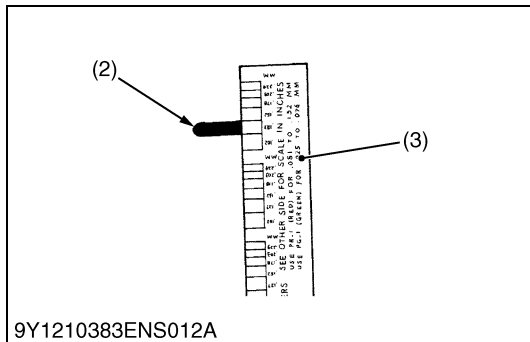
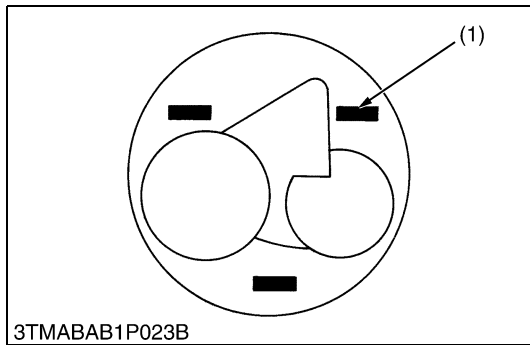

### Top Clearance

1. Remove the cylinder head.
2. With the piston at TDC, use grease to affix three or four plastigauges (1) of a diameter 1.5 mm (0.059 in.) × 5.0 to 7.0 mm (0.20 to 0.27 in.) long to the crown of the piston; keep the gauges away from the intake valve and combustion chamber fittings.
3. Take the piston to an intermediate position, install the cylinder head and tighten the head screws to the specified torque.
4. Turn the crankshaft so the piston goes through TDC.
5. Remove the cylinder head and compare the width of the crushed plastigauges (2) with the scale (3).
6. If they are out of spec, check the oil clearance of the crank pin, journals and piston pin.

### ■ IMPORTANT

- **Top clearance = Width of the crushed plastigauge (2).**

Top clearance	Factory specification	0.55 to 0.70 mm 0.022 to 0.027 in.
Tightening torque	Cylinder head screw	93.2 to 98.0 N·m 9.50 to 10.0 kgf·m 68.8 to 72.3 lbf·ft

- (1) Plastigauge (3) Scale  
(2) Crushed Plastigauge

9Y1211109ENS0092US0

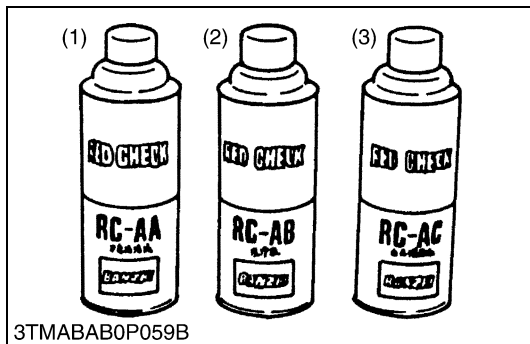

### Cylinder Head Flaw

1. Prepare an air spray red check (Code No. 07909-31371).
2. Clean the surface of the cylinder head with the detergent (2).
3. Spray the cylinder head surface with the red permeative liquid (1). Leave it five to ten minutes after spraying.
4. Wash away the red permeative liquid on the cylinder head surface with the detergent (2).
5. Spray the cylinder head surface with the white developer (3).
6. If flawed, it can be identified as red marks.

- (1) Red Permeative Liquid (3) White Developer  
(2) Detergent

9Y1211109ENS0093US0

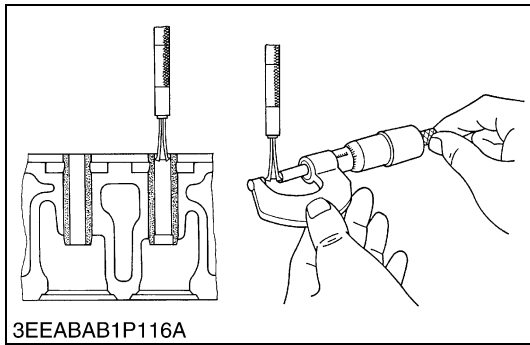
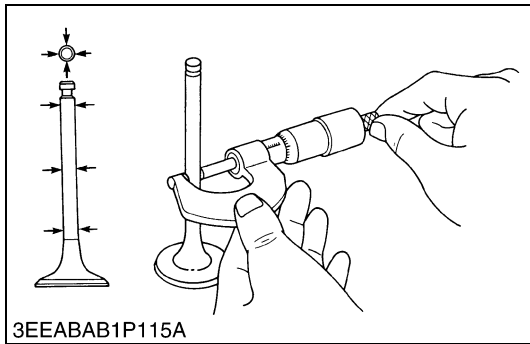
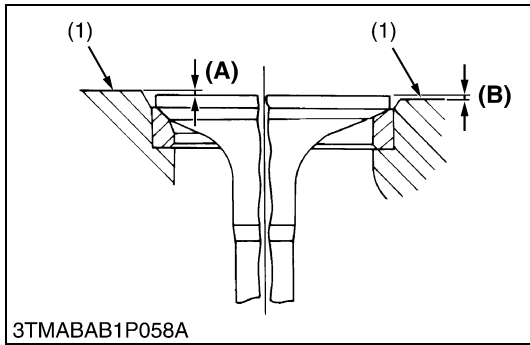
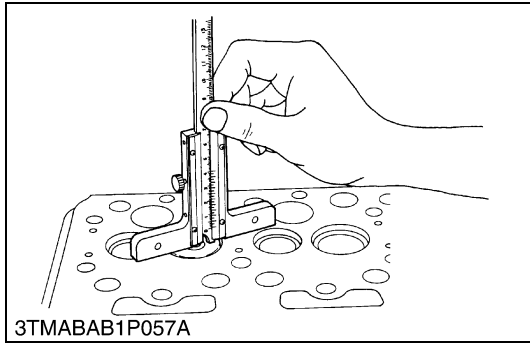

**Valve Recessing**

1. Clean the cylinder head surface, valve face and valve seat.
2. Insert the valve into the valve guide.
3. Measure the valve recessing with a depth gauge.
4. If the measurement exceeds the allowable limit, replace the valve.
5. If it still exceeds the allowable limit after replacing the valve, replace the cylinder head.

Valve recessing	Factory specification	0.05 (protrusion) to 0.15 (recessing) mm 0.0020 (protrusion) to 0.0059 (recessing) in.
	Allowable limit	0.40 (recessing) mm 0.0157 (recessing) in.

(1) Cylinder Head Surface

(A) Recessing

(B) Protrusion

9Y1211109ENS0094US0

**Clearance between Valve Stem and Valve Guide**

1. Remove carbon from the valve guide section.
2. Measure the valve stem O.D. with an outside micrometer.
3. Measure the valve guide I.D. with a small hole gauge, and calculate the clearance.
4. If the clearance exceeds the allowable limit, replace the valves. If it still exceeds the allowable limit, replace the valve guide.

Clearance between valve stem and valve guide	Factory specification	0.040 to 0.070 mm 0.00157 to 0.00276 in.
	Allowable limit	0.10 mm 0.0039 in.

Valve stem O.D.	Factory specification	7.960 to 7.975 mm 0.3134 to 0.3139 in.
Valve guide I.D.	Factory specification	8.015 to 8.030 mm 0.3156 to 0.3161 in.

9Y1211109ENS0095US0

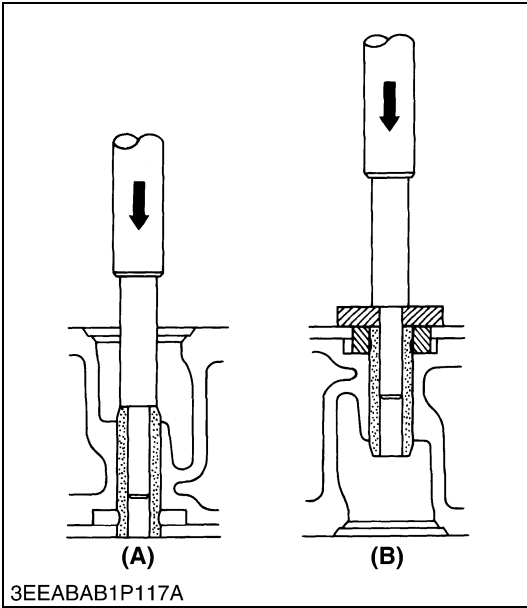

**Replacing Valve Guide**

**(When removing)**

1. Press out the used valve guide using a valve guide replacing tool.

**(When installing)**

1. Clean a new valve guide and valve guide bore, and apply engine oil to them.
2. Press in a new valve guide using a valve guide replacing tool.
3. Ream precisely the I.D. of the valve guide to the specified dimension.

Valve guide I.D. (Intake and exhaust)	Factory specification	8.015 to 8.030 mm 0.3156 to 0.3161 in.
--	-----------------------	---

**■ IMPORTANT**

- Do not hit the valve guide with a hammer during replacement.

(A) When Removing

(B) When Installing

9Y1211109ENS0096US0

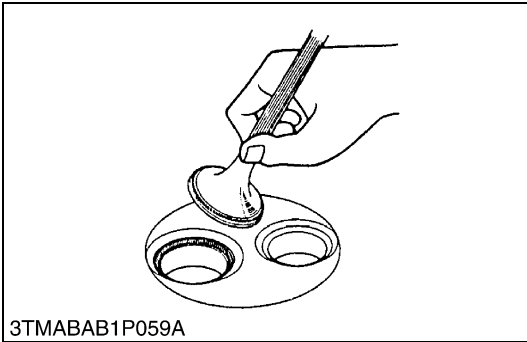

**Valve Seating**

1. Coat the valve face lightly with prussian blue and put the valve on its seat to check the contact.
2. If the valve does not seat all the way around the valve seat or the valve contact is less than 70 %, correct the valve seating as follows.
3. If the valve contact does not comply with the reference valve, replace the valve or correct the contact of valve seating.

Valve seat width	Factory specification	2.12 mm 0.0835 in.
------------------	-----------------------	-----------------------

- (1) Correct  
(2) Incorrect

(3) Incorrect

9Y1211109ENS0097US0

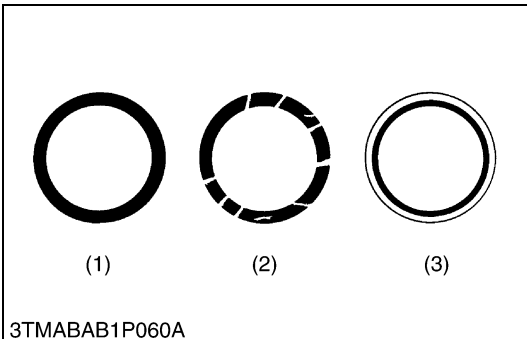



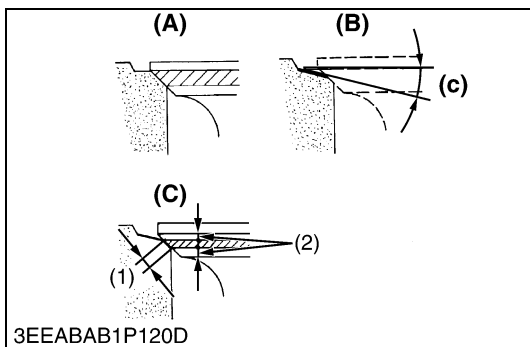
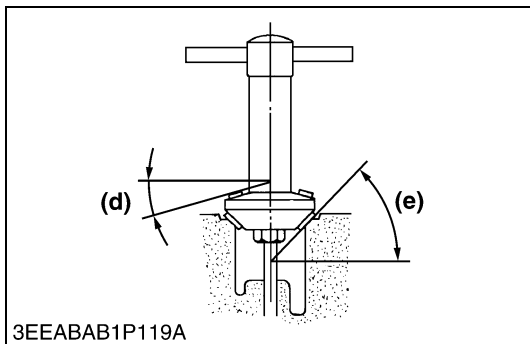
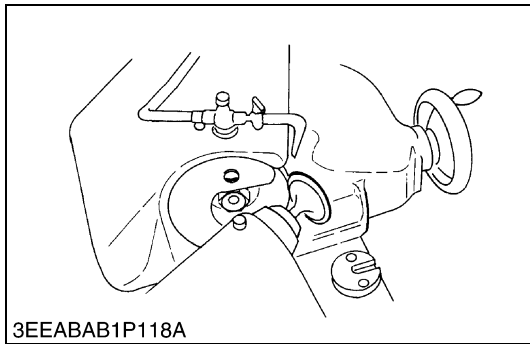

**Correcting Valve and Valve Seat**

■ **NOTE**

- Before correcting the valve and seat, check the valve stem and the I.D. of valve guide section, and repair them if necessary.
- After correcting the valve seat, be sure to check the valve recessing.

**1) Correcting Valve**

1. Correct the valve with a valve refacer.

**2) Correcting Valve Seat**

Valve face angle	Factory specification	IN.	1.0 rad 60 °
		EX.	0.79 rad 45 °

**2) Correcting Valve Seat**

1. Slightly correct the seat surface with a 1.0 rad (60 °) (intake valve) or 0.79 rad (45 °) (exhaust valve) valve seat cutter.
2. Resurface the seat surface with a 0.52 rad (30 °) valve seat cutter to intake valve seat and with a 0.26 rad (15 °) valve seat cutter to exhaust valve seat so that the width is close to specified valve seat width (2.12 mm, 0.0835 in.).
3. After resurfacing the seat, inspect for even valve seating, apply a thin film of compound between the valve face and valve seat, and fit them with valve lapping tool.
4. Check the valve seating with prussian blue. The valve seating surface should show good contact all the way around.

Valve face angle	Factory specification	IN.	1.0 rad 60 °
		EX.	0.79 rad 45 °

- (1) Valve Seat Width  
(2) Identical Dimensions

- (A) Check Contact  
(B) Correct Seat Width  
(C) Check Contact  
(a) 0.26 rad (15 °) or 0.52 rad (30 °)  
(b) 0.79 rad (45 °) or 1.0 rad (60 °)  
(c) 0.52 rad (30 °) or 0.26 rad (15 °)

9Y1211109ENS0098US0

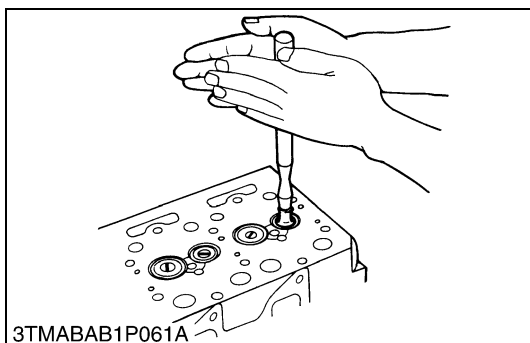

**Valve Lapping**

1. Apply compound evenly to the valve lapping surface.
2. Insert the valve into the valve guide. Lap the valve onto its seat with a valve flapper or screwdriver.
3. After lapping the valve, wash the compound away and apply oil, then repeat valve lapping with oil.
4. Apply prussian blue to the contact surface to check the seated rate. If it is less than 70 %, repeat valve lapping again.

■ **IMPORTANT**

- When valve lapping is performed, be sure to check the valve recessing and adjust the valve clearance after assembling the valve.

9Y1211109ENS0099US0

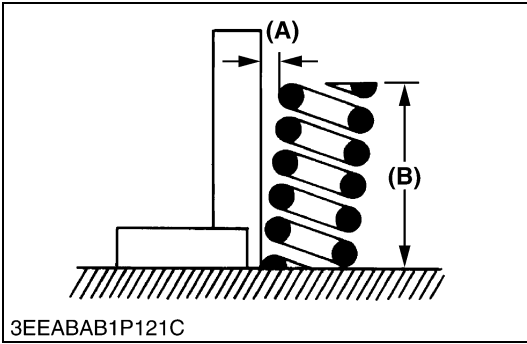

**Free Length and Tilt of Valve Spring**

1. Measure the free length **(B)** of valve spring with vernier calipers. If the measurement is less than the allowable limit, replace it.
2. Put the valve spring on a surface plate, place a square on the side of the valve spring.
3. Check to see if the entire side is in contact with the square. Rotate the valve spring and measure the maximum tilt **(A)**. If the measurement exceeds the allowable limit, replace it.
4. Check the entire surface of the valve spring for scratches. If there is any problem, replace it.

Free length <b>(A)</b>	Allowable limit	1.0 mm 0.039 in.
------------------------	-----------------	---------------------

Free length <b>(B)</b>	Factory specification	41.7 to 42.2 mm 1.65 to 1.66 in.
	Allowable limit	41.2 mm 1.62 in.

**(A) Tilt**

**(B) Free Length**

9Y1211109ENS0100US0

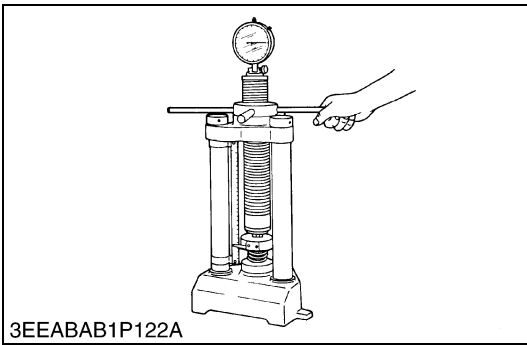

**Valve Spring Setting Load**

1. Place the valve spring on a tester and compress it to the same length it is actually compressed in the engine.
2. Read the compression load on the gauge.
3. If the measurement is less than the allowable limit, replace it.

Setting load / Setting length	Factory specification	118 N / 35.0 mm 12.0 kgf / 35.0 mm 26.5 lbs / 1.38 in.
	Allowable limit	100 N / 35.0 mm 10.2 kgf / 35.0 mm 22.5 lbs / 1.38 in.

9Y1211109ENS0101US0

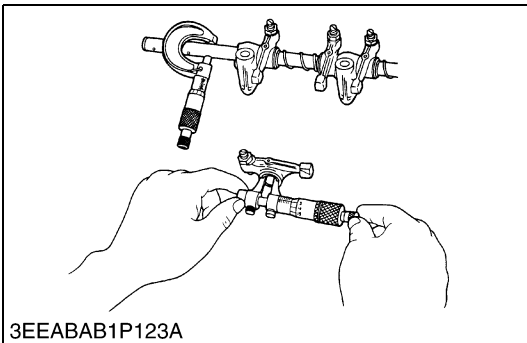

**Oil Clearance between Rocker Arm and Rocker Arm Shaft**

1. Measure the rocker arm shaft O.D. with an outside micrometer.
2. Measure the rocker arm I.D. with an inside micrometer, and then calculate the oil clearance.
3. If the oil clearance exceeds the allowable limit, replace the rocker arm and measure the oil clearance again. If it still exceeds the allowable limit, replace also the rocker arm shaft.

Oil clearance between rocker arm and rocker arm shaft	Factory specification	0.016 to 0.045 mm 0.00063 to 0.00177 in.
	Allowable limit	0.10 mm 0.0039 in.

Rocker arm shaft O.D.	Factory specification	13.973 to 13.984 mm 0.55012 to 0.55055 in.
Rocker arm I.D.	Factory specification	14.000 to 14.018 mm 0.55119 to 0.55188 in.

9Y1211109ENS0102US0

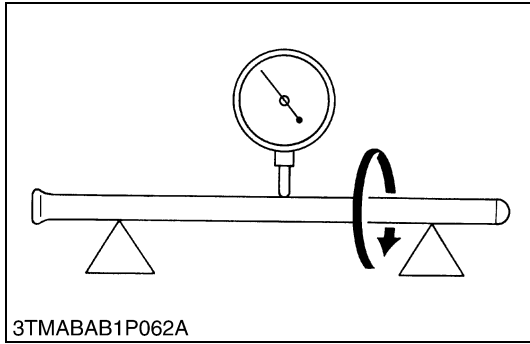

3TMABAB1P062A

**Push Rod Alignment**

1. Place the push rod on V blocks.
2. Measure the push rod alignment.
3. If the measurement exceeds the allowable limit, replace the push rod.

Push rod alignment	Allowable limit	0.25 mm 0.0098 in.
--------------------	-----------------	-----------------------

9Y1211109ENS0103US0

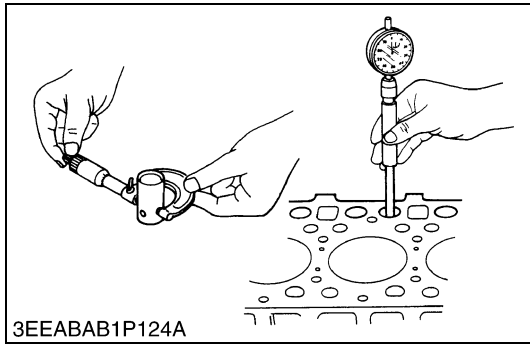

3EEABAB1P124A

**Oil Clearance between Tappet and Tappet Guide Bore**

1. Measure the tappet O.D. with an outside micrometer.
2. Measure the I.D. of the tappet guide bore with a cylinder gauge, and calculate the oil clearance.
3. If the oil clearance exceeds the allowable limit or the tappet is damaged, replace the tappet.

Oil clearance between tappet and tappet guide bore	Factory specification	0.020 to 0.062 mm 0.00079 to 0.00244 in.
	Allowable limit	0.07 mm 0.003 in.

Tappet O.D.	Factory specification	23.959 to 23.980 mm 0.94327 to 0.94409 in.
-------------	-----------------------	---

Tappet guide bore I.D.	Factory specification	24.000 to 24.021 mm 0.94489 to 0.94570 in.
------------------------	-----------------------	---

9Y1211109ENS0104US0

**(2) Timing Gears, Camshaft and Fuel Camshaft**

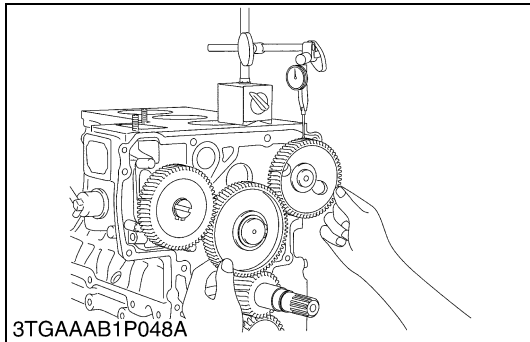

3TGAAAB1P048A

**Timing Gear Backlash**

1. Set a dial indicator (lever type) with its tip on the gear tooth.
2. Move the gear to measure the backlash, holding its mating gear.
3. If the backlash exceeds the allowable limit, check the oil clearance of the shafts and the gear.
4. If the oil clearance is not proper, replace the gear.

Backlash between idle gear and crank gear	Factory specification	0.0415 to 0.1122 mm 0.94327 to 0.94409 in.
	Allowable limit	0.15 mm 0.0059 in.

Backlash between idle gear and cam gear	Factory specification	0.0415 to 0.1154 mm 0.001634 to 0.004543 in.
	Allowable limit	0.15 mm 0.0059 in.

Backlash between idle gear and injection pump gear	Factory specification	0.0415 to 0.1154 mm 0.001634 to 0.004543 in.
	Allowable limit	0.15 mm 0.0059 in.

Backlash between crank gear oil pump gear	Factory specification	0.0415 to 0.1090 mm 0.001634 to 0.004291 in.
	Allowable limit	0.15 mm 0.0059 in.

9Y1211109ENS0105US0

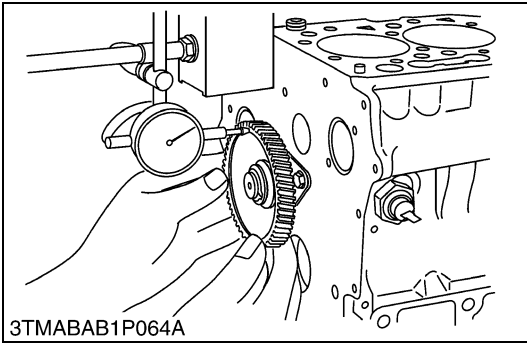

**Idle Gear Side Clearance**

1. Set a dial indicator with its tip on the idle gear.
2. Measure the side clearance by moving the idle gear to the front and rear.
3. If the measurement exceeds the allowable limit, replace the idle gear collar.

Idle gear side clearance	Factory specification	0.12 to 0.48 mm 0.0048 to 0.018 in.
	Allowable limit	0.9 mm 0.04 in.

9Y1211109ENS0106US0

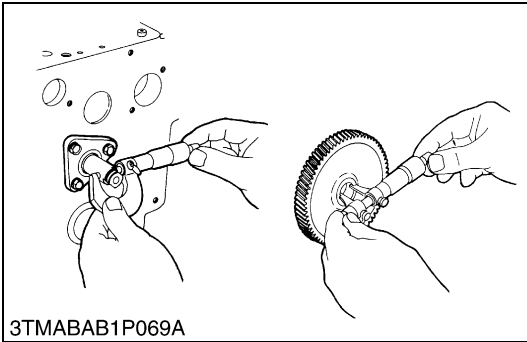

**Oil Clearance between Idle Gear Shaft and Idle Gear Bushing**

1. Measure the idle gear shaft O.D. with an outside micrometer.
2. Measure the idle gear bushing I.D. with an inside micrometer, and calculate the oil clearance.
3. If the oil clearance exceeds the allowable limit, replace the bushing.
4. If it still exceeds the allowable limit, replace the idle gear shaft.

Oil clearance between idle gear shaft and idle gear bushing	Factory specification	0.025 to 0.066 mm 0.00099 to 0.0025 in.
	Allowable limit	0.10 mm 0.0039 in.

Idle gear shaft O.D.	Factory specification	37.959 to 37.975 mm 1.4945 to 1.4950 in.
Idle gear bushing I.D.	Factory specification	38.000 to 38.025 mm 1.4961 to 1.4970 in.

9Y1211109ENS0107US0

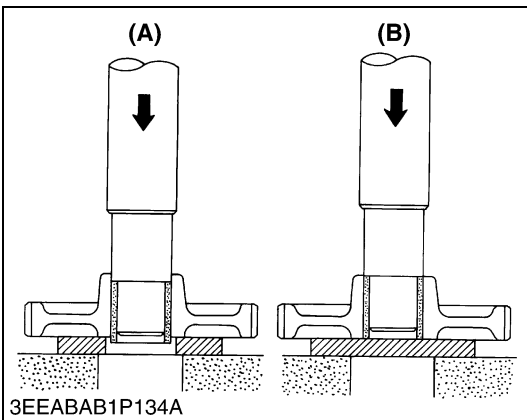

**Replacing Idle Gear Bushing**

**(When removing)**

1. Press out the used idle gear bushing using an idle gear bushing replacing tool.

**(When installing)**

1. Clean a new idle gear bushing and idle gear bore, and apply engine oil to them.
2. Press in a new bushing using an idle gear bushing replacing tool, until it is flush with the end of the idle gear.

(A) When removing

(B) When installing

9Y1211109ENS0108US0

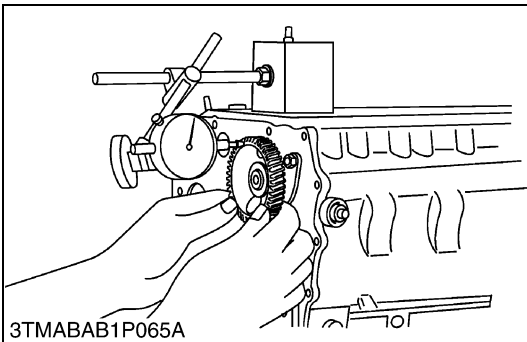

**Camshaft Side Clearance**

1. Set a dial indicator with its tip on the cam gear.
2. Measure the side clearance by moving the cam gear to the front and rear.
3. If the measurement exceeds the allowable limit, replace the camshaft stopper.

Camshaft side clearance	Factory specification	0.07 to 0.22 mm 0.0028 to 0.0087 in.
	Allowable limit	0.30 mm 0.0118 in.

9Y1211109ENS0109US0

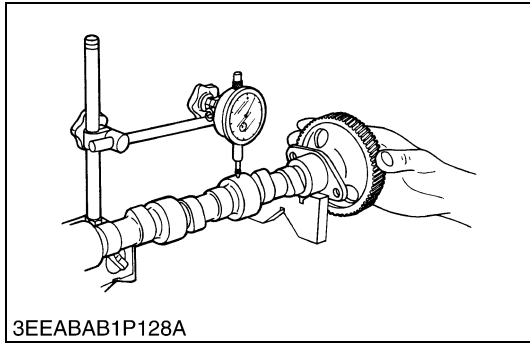

**Camshaft Alignment**

1. Support the camshaft with V blocks on the surface plate at both end journals.
2. Set a dial indicator with its tip on the intermediate journal.
3. Measure the camshaft alignment.
4. If the measurement exceeds the allowable limit, replace the camshaft.

Camshaft alignment	Factory specification	0.01 mm 0.0004 in.
--------------------	-----------------------	-----------------------

9Y1211109ENS0110US0

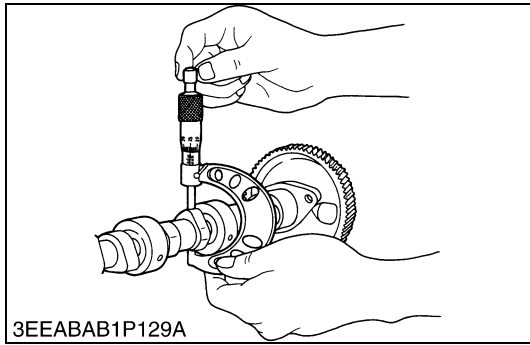

**Cam Height**

1. Measure the height of the cam at its highest point with an outside micrometer.
2. If the measurement is less than the allowable limit, replace the camshaft.

Cam height of intake	Factory specification	33.90 mm 1.335 in.
	Allowable limit	33.85 mm 1.333 in.

Cam height of exhaust	Factory specification	33.90 mm 1.335 in.
	Allowable limit	33.85 mm 1.333 in.

9Y1211109ENS0111US0

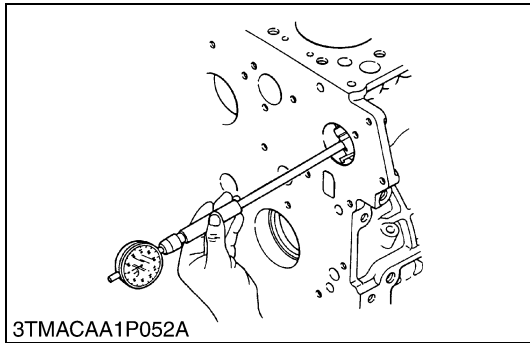

**Oil Clearance of Camshaft Journal**

1. Measure the camshaft journal O.D. with an outside micrometer.
2. Measure the cylinder block bore I.D. for camshaft with a cylinder gauge, and calculate the oil clearance.
3. If the oil clearance exceeds the allowable limit, replace the camshaft.

Oil clearance of camshaft journal	Factory specification	0.050 to 0.091 mm 0.0020 to 0.0035 in.
	Allowable limit	0.15 mm 0.0059 in.

Camshaft journal O.D.	Factory specification	39.934 to 39.950 mm 1.5722 to 1.5728 in.
-----------------------	-----------------------	---

Cylinder block bore I.D.	Factory specification	40.000 to 40.025 mm 1.5748 to 1.5757 in.
--------------------------	-----------------------	---

9Y1211109ENS0112US0

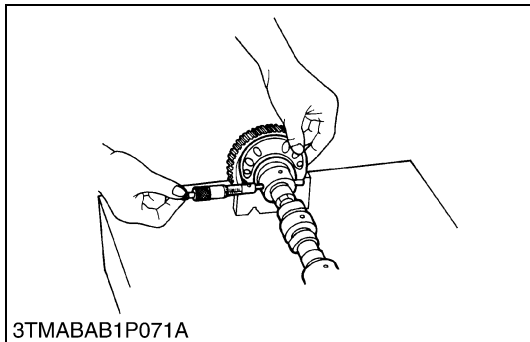

### (3) Piston and Connecting Rod

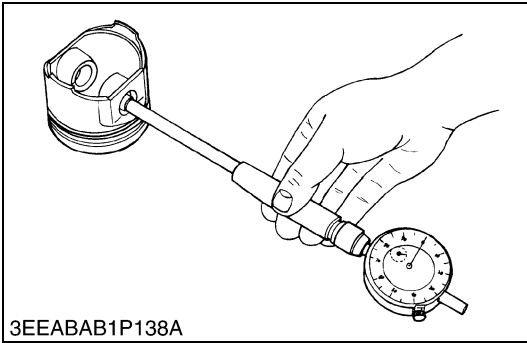

#### Piston Pin Bore I.D.

1. Measure the piston pin bore I.D. in both the horizontal and vertical directions with a cylinder gauge.
2. If the measurement exceeds the allowable limit, replace the piston.

Piston pin bore I.D.	Factory specification	25.000 to 25.013 mm 0.98426 to 0.98476 in.
	Allowable limit	25.05 mm 0.9862 in.

9Y1211109ENS0113US0

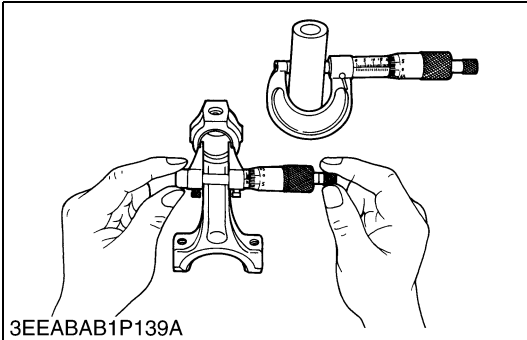

#### Oil Clearance between Piston Pin and Small End Bushing

1. Measure the piston pin O.D. where it contacts the bushing with an outside micrometer.
2. Measure the small end bushing I.D. with an inside micrometer, and calculate the oil clearance.
3. If the oil clearance exceeds the allowable limit, replace the bushing. If it still exceeds the allowable limit, replace the piston pin.

Oil clearance between piston pin and small end bushing	Factory specification	0.014 to 0.038 mm 0.00056 to 0.0014 in.
	Allowable limit	0.15 mm 0.0059 in.

Piston pin O.D.	Factory specification	25.002 to 25.011 mm 0.98433 to 0.98468 in.
Small end bushing I.D.	Factory specification	25.025 to 25.040 mm 0.98524 to 0.98582 in.

9Y1211109ENS0114US0

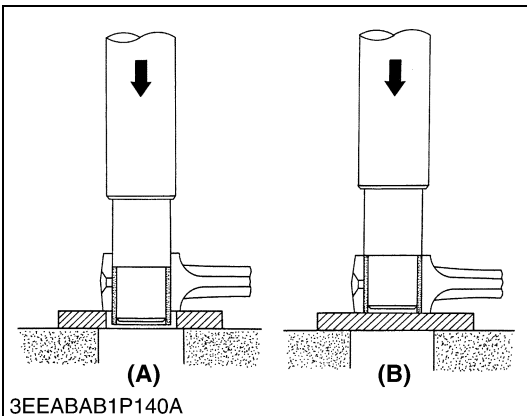

#### Replacing Connecting Rod Small End Bushing

##### **(When removing)**

1. Press out the small end bushing with a connecting rod small end bushing replacing tool.

##### **(When installing)**

1. Clean a new small end bushing and bore, and apply engine oil to them.
2. Press fit a new bushing, taking due care to see that the connecting rod hole matches the bushing hole.

(A) When removing

(B) When installing

9Y1211109ENS0115US0

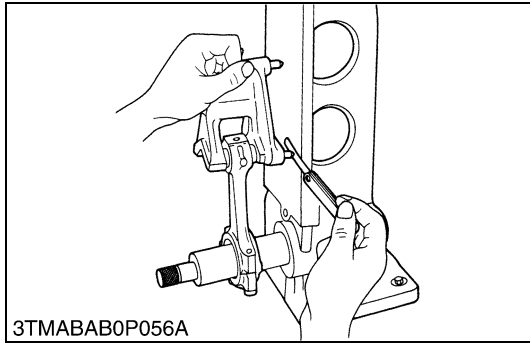

**Connecting Rod Alignment**

■ **NOTE**

- Since the I.D. of the connecting rod small end bushing is the basis of this check, check bushing for wear beforehand.

1. Install the piston pin into the connecting rod.
2. Install the connecting rod on the connecting rod alignment tool.
3. Put a gauge over the piston pin, and move it against the face plate.
4. If the gauge does not fit squarely against the face plate, measure the space between the pin of the gauge and the face plate.
5. If the measurement exceeds the allowable limit, replace the connecting rod.

Connecting rod alignment	Allowable limit	0.05 mm 0.002 in.
--------------------------	-----------------	----------------------

9Y1211109ENS0116US0

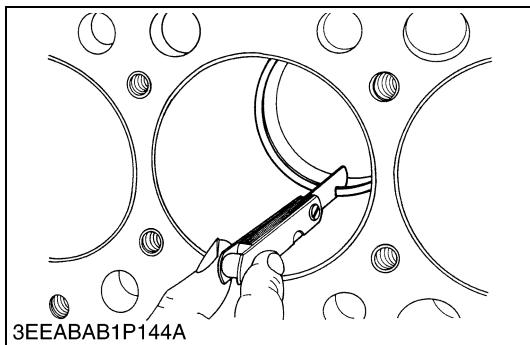

**Piston Ring Gap**

1. Insert the piston ring into the lower part of the liner (the least worn out part) with the piston.
2. Measure the ring gap with a feeler gauge.
3. If the gap exceeds the allowable limit, replace the ring.

Top ring	Factory specification	0.25 to 0.40 mm 0.0099 to 0.015 in.
	Allowable limit	1.25 mm 0.0492 in.

Second ring	Factory specification	0.30 to 0.45 mm 0.012 to 0.017 in.
Second ring	Allowable limit	1.25 mm 0.0492 in.

Oil ring	Factory specification	0.25 to 0.45 mm 0.0099 to 0.017 in.
	Allowable limit	1.25 mm 0.0492 in.

9Y1211109ENS0117US0

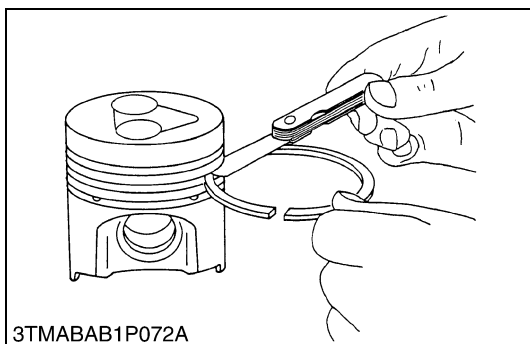

**Clearance between Piston Ring and Groove**

1. Remove carbon from the ring grooves.
2. Measure the clearance between the ring and the groove with a feeler gauge or depth gauge.
3. If the clearance exceeds the allowable limit, replace the ring since compression leak and oil shortage result.
4. If the clearance still exceeds the allowable limit after replacing the ring, replace the piston.

Second ring	Factory specification	0.0930 to 0.128 mm 0.00367 to 0.00503 in.
	Allowable limit	0.2 mm 0.0079 in.

Oil ring	Factory specification	0.020 to 0.060 mm 0.00079 to 0.0023 in.
	Allowable limit	0.15 mm 0.0059 in.

9Y1211109ENS0118US0

### (4) Crankshaft

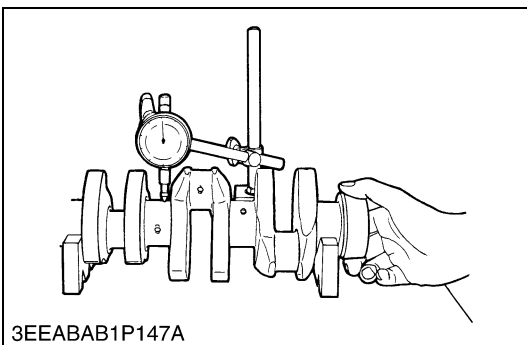
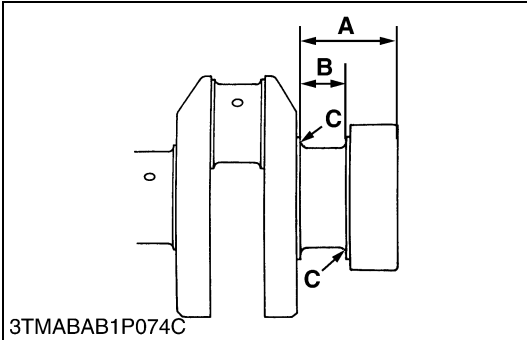
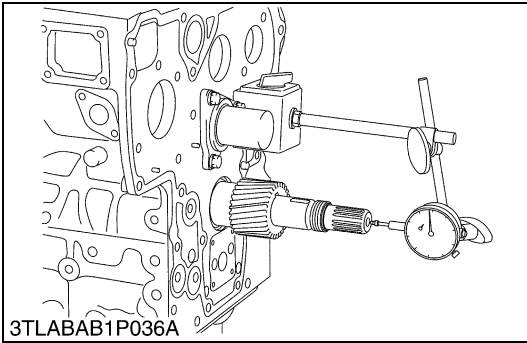

#### Side Clearance of Crankshaft

1. Set a dial indicator with its tip on the end of the crankshaft.
2. Measure the side clearance by moving the crankshaft to the front and rear.
3. If the measurement exceeds the allowable limit, replace the thrust bearings.
4. If the same size bearing is useless because of the crankshaft journal wear, replace it with an oversize one referring to the table and figure.

Crankshaft side clearance	Factory specification	0.15 to 0.31 mm 0.0059 to 0.012 in.
	Allowable limit	0.5 mm 0.02 in.

#### (Reference)

- Oversize dimensions of crankshaft journal

Oversize	0.2 mm 0.008 in.	0.4 mm 0.02 in.
Dimension A	54.50 to 54.70 mm 2.146 to 2.153 in.	54.60 to 54.80 mm 2.150 to 2.157 in.
Dimension B	26.20 to 26.25 mm 1.032 to 1.033 in.	26.40 to 26.45 mm 1.040 to 1.041 in.
Dimension C	2.8 to 3.2 mm radius 0.11 to 0.12 in. radius	2.8 to 3.2 mm radius 0.11 to 0.12 in. radius

The crankshaft journal must be fine-finished to higher than = 0.4S

9Y1211109ENS0119US0

#### Crankshaft Alignment

1. Support the crankshaft with V blocks on the surface plate and set a dial indicator with its tip on the intermediate journal at right angle.
2. Rotate the crankshaft on the V blocks and get the misalignment (half of the measurement).
3. If the misalignment exceeds the allowable limit, replace the crankshaft.

Crankshaft alignment	Allowable limit	0.02 mm 0.0008 in.
----------------------	-----------------	-----------------------

9Y1211109ENS0120US0



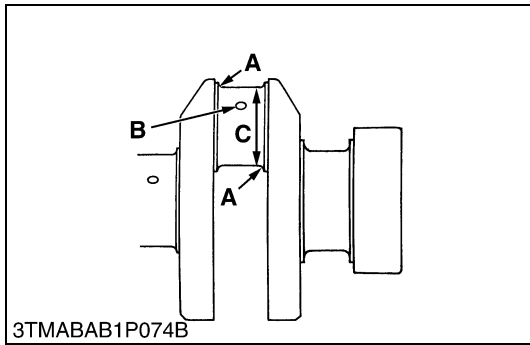
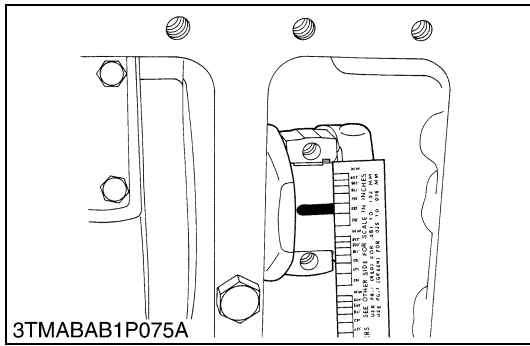

**Oil Clearance between Crankpin and Crankpin Bearing**

1. Clean the crankpin and crankpin bearing.
2. Put a strip of plastigauge on the center of the crankpin.
3. Install the connecting rod cap and tighten the connecting rod screws to the specified torque, and remove the cap again.
4. Measure the amount of the flattening with the scale, and get the oil clearance.
5. If the oil clearance exceeds the allowable limit, replace the crankpin bearing.
6. If the same size bearing is useless because of the crankpin wear, replace it with an undersize one referring to the table and figure.

**NOTE**

- Never insert the plastigauge into the crankpin oil hole.
- Be sure not to move the crankshaft while the connecting rod screws are tightened.

Oil clearance between crankpin and crankpin bearing	Factory specification	0.025 to 0.087 mm 0.00099 to 0.0034 in.
	Allowable limit	0.2 mm 0.0079 in.

Crankpin O.D.	Factory specification	46.959 to 46.975 mm 1.8488 to 1.8494 in.
Crankpin bearing I.D.	Factory specification	47.000 to 47.046 mm 1.8504 to 1.8522 in.

**(Reference)**

- Undersize dimensions of crankpin

Undersize	0.2 mm 0.008 in.	0.4 mm 0.016 in.
Dimension A	3.3 to 3.7 mm radius 0.13 to 0.14 in. radius	3.3 to 3.7 mm radius 0.13 to 0.14 in. radius
Dimension B	1.0 to 1.5 mm radius 0.040 to 0.059 in. radius	1.0 to 1.5 mm radius 0.040 to 0.059 in. radius
Dimension C	46.759 to 46.775 mm dia. 1.8409 to 1.8415 in. dia.	46.559 to 46.575 mm dia. 1.8331 to 1.8336 in. dia.

The crankpin must be fine-finished to higher than = 0.4S  
 \*Holes to be de-burred and edges rounded with 1.0 to 1.5 mm (0.040 to 0.059 in.) relief.

9Y1211109ENS0121US0

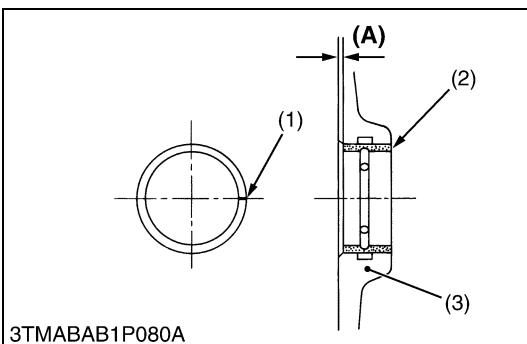
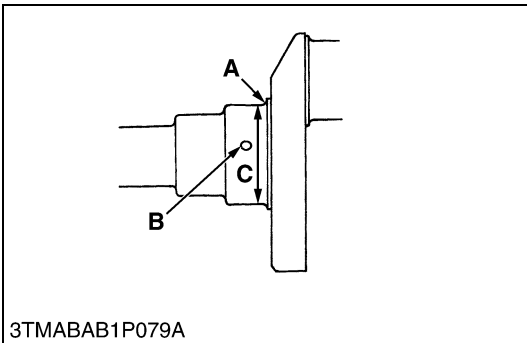
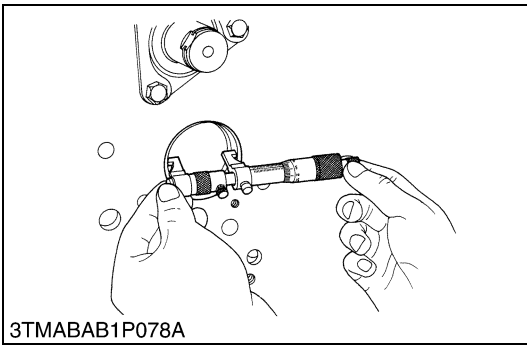
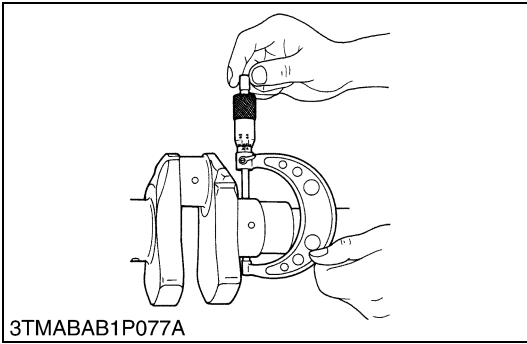

**Oil Clearance between Crankshaft Journal and Crankshaft Bearing 1**

1. Measure the O.D. of the crankshaft journal with an outside micrometer.
2. Measure the I.D. of the crankshaft bearing 1 with an inside micrometer, and calculate oil clearance.
3. If the clearance exceeds the allowable limit, replace the crankshaft bearing 1.
4. If the same size bearing is useless because of the crankshaft journal wear, replace it with an undersize one referring to the table and figure.

Oil clearance between crankshaft journal and crankshaft bearing 1	Factory specification	0.040 to 0.118 mm 0.00158 to 0.00464 in.
	Allowable limit	0.2 mm 0.0079 in.

Crankshaft journal O.D.	Factory specification	59.921 to 59.940 mm 2.3591 to 2.3598 in.
Crankshaft bearing 1 I.D.	Factory specification	59.980 to 60.039 mm 2.3615 to 2.3637 in.

**(Reference)**

- Undersize dimensions of crankshaft journal

Undersize	0.2 mm 0.008 in.	0.4 mm 0.016 in.
Dimension A	2.8 to 3.2 mm radius 0.11 to 0.12 in. radius	2.8 to 3.2 mm radius 0.11 to 0.12 in. radius
Dimension B	1.0 to 1.5 mm radius 0.040 to 0.059 in. radius	1.0 to 1.5 mm radius 0.040 to 0.059 in. radius
Dimension C	59.721 to 59.740 mm dia. 2.3513 to 2.3519 in. dia.	59.521 to 59.540 mm dia. 2.3434 to 2.3440 in. dia.

The crankshaft journal must be fine-finished to higher than = 0.4S  
 \*Holes to be de-burred and edges rounded with 1.0 to 1.5 mm (0.040 to 0.059 in.) relief.

9Y1211109ENS0122US0

**Replacing Crankshaft Bearing 1**

**(When removing)**

1. Press out the used crankshaft bearing 1 using a crankshaft bearing 1 replacing tool.

**(When installing)**

1. Clean a new crankshaft bearing 1 and crankshaft journal bore, and apply engine oil to them.
2. Using a crankshaft bearing 1 replacing tool, press in a new bearing 1 (2) so that its seam (1) directs toward the exhaust manifold side.

Dimension (A)	Factory specification	4.20 to 4.50 mm 0.166 to 0.177 in.
---------------	-----------------------	---------------------------------------

- (1) Seam
- (2) Crankshaft Bearing 1
- (3) Cylinder Block

**(A) Dimension**

9Y1211109ENS0123US0

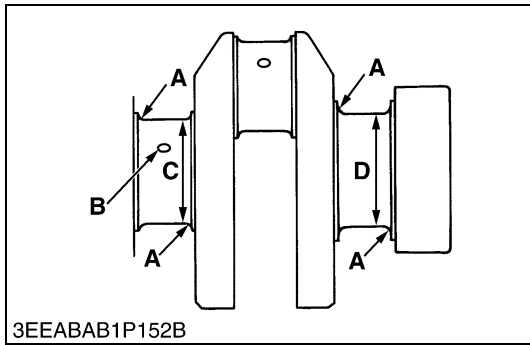
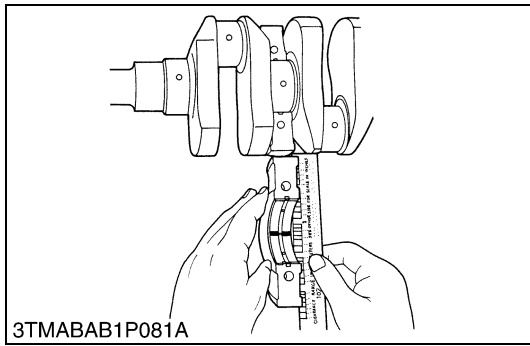

**Oil Clearance between Crankshaft Journal and Crankshaft Bearing 2**

1. Put a strip of plastigauge on the centre of the journal.
2. Install the bearing case and tighten the bearing case screws 1 to the specified torque, and remove the bearing case again.
3. Measure the amount of the flattening with the scale and get the oil clearance.
4. If the clearance exceeds the allowable limit, replace the crankshaft bearing 2.
5. If the same size bearing is useless because of the crankshaft journal wear, replace it with an undersize one referring to the table and figure.

**NOTE**

- Be sure not to move the crankshaft while the bearing case screws are tightened.

Oil clearance between crankshaft and crankshaft bearing 2	Factory specification	0.0400 to 0.104 mm 0.00158 to 0.00409 in.
	Allowable limit	0.20 mm 0.0079 in.

Crankshaft O.D.	Factory specification	59.921 to 59.940 mm 2.3591 to 2.3598 in.
Crankshaft bearing 2 I.D.	Factory specification	59.980 to 60.025 mm 2.3615 to 2.3631 in.

**(Reference)**

- Undersize dimensions of crankshaft journal

Undersize	0.2 mm 0.008 in.	0.4 mm 0.016 in.
Dimension A	2.8 to 3.2 mm radius 0.11 to 0.12 in. radius	2.8 to 3.2 mm radius 0.11 to 0.12 in. radius
Dimension B	1.0 to 1.5 mm radius 0.040 to 0.059 in. radius	1.0 to 1.5 mm radius 0.040 to 0.059 in. radius
Dimension C, D	59.721 to 59.740 mm dia. 2.3513 to 2.3519 in. dia.	59.521 to 59.540 mm dia. 2.3434 to 2.3440 in. dia.

The crankshaft journal must be fine-finished to higher than = 0.4S  
 \*Holes to be de-burred and edges rounded with 1.0 to 1.5 mm (0.040 to 0.059 in.) relief.

9Y1211109ENS0124US0

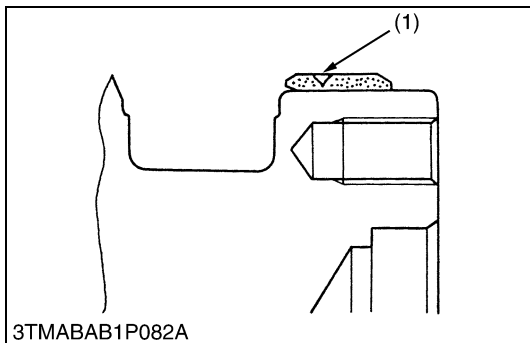

**Crankshaft Sleeve Wear**

1. Check the wear on the crankshaft sleeve (1).
2. If the wear exceeds the allowable limit or when the engine oil leaks, replace the crankshaft sleeve.

Wear of sleeve	Allowable limit	0.1 mm 0.0039 in.
----------------	-----------------	----------------------

(1) Crankshaft Sleeve

9Y1211109ENS0125US0

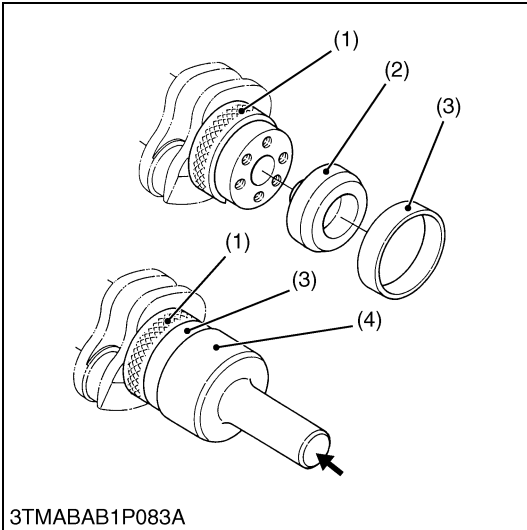

**Replacing Crankshaft Sleeve**

1. Remove the used crankshaft sleeve using a special-use puller set (Code No. 07916-32091).
2. Set the sleeve guide (2) to the crankshaft.
3. Set the stopper (1) to the crankshaft as shown in figure.
4. Heat a new sleeve to a temperature between 150 to 200 °C (302 to 392 °F), and fix the sleeve to the crankshaft as shown in figure.
5. Press fit the sleeve using the auxiliary socket for pushing (4).

**NOTE**

- Mount the sleeve with its largely chamfered surface facing outward.

- (1) Stopper
- (2) Sleeve Guide
- (3) Crankshaft Sleeve
- (4) Auxiliary Socket for Pushing
- (5) Crankshaft

9Y1211109ENS0126US0

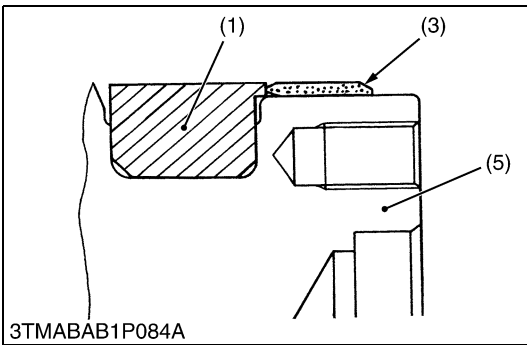

**(5) Cylinder**

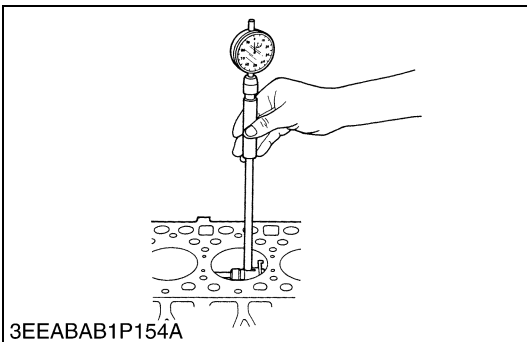

**Cylinder Wear**

1. Measure the I.D. of the cylinder at the six positions (see figure) with a cylinder gauge to find the maximum and minimum I.D.'s.
2. Get the difference (Maximum wear) between the maximum and the minimum I.D.'s.
3. If the wear exceeds the allowable limit, bore and hone to the oversize dimension. (Refer to "Correcting Cylinder".)
4. Visually check the cylinder wall for scratches. If deep scratches are found, the cylinder should be bored. (Refer to "Correcting Cylinder".)

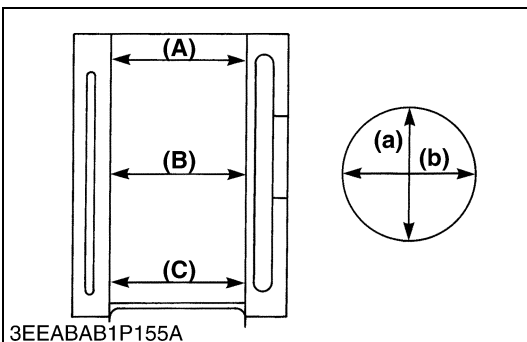

Cylinder I.D.	Factory specification	87.000 to 87.022 mm 3.4252 to 3.4260 in.
Maximum wear	Allowable limit	87.150 mm 3.4311 in.

- (A) Top
- (B) Middle
- (C) Bottom (Skirt)
- (a) Right-angled to Piston Pin
- (b) Piston Pin Direction

9Y1211109ENS0127US0

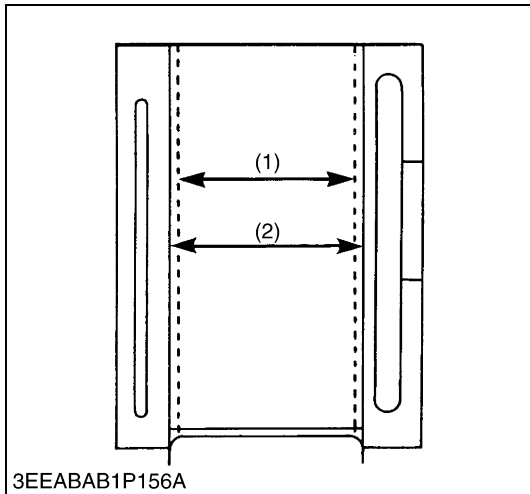

**Correcting Cylinder (Oversize +0.25 mm)**

- When the cylinder is worn beyond the allowable limit, bore and hone it to the specified dimension.

Oversize cylinder I.D.	Factory specification	87.250 to 87.272 mm 3.4351 to 3.4359 in.
Maximum wear	Allowable limit	87.400 mm 3.4409 in.
Finishing	Horn to 2.2 to 3.0 µm Rmax. (0.00087 to 0.00118 in. Rmax.)	

- Replace the piston and piston rings with oversize ones. Oversize: 0.25 mm (0.0098 in.).

**NOTE**

- When the oversize cylinder is worn beyond the allowable limit, replace the cylinder block with a new one.

(1) Cylinder I.D. (Before Correction) (2) Oversize Cylinder I.D.

9Y1211109ENS0128US0

**(6) Oil Pump**

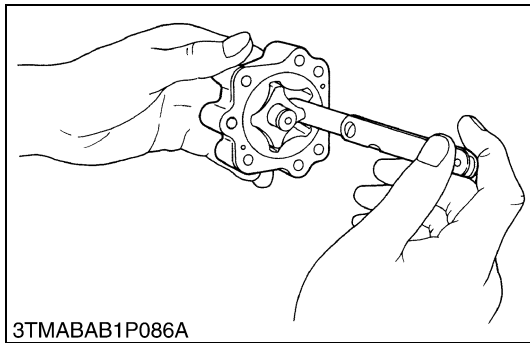

**Rotor Lobe Clearance**

- Measure the clearance between lobes of the inner rotor and the outer rotor with a feeler gauge.
- Measure the clearance between the outer rotor and the pump body with a feeler gauge.
- If the clearance exceeds the factory specifications, replace the oil pump rotor assembly.

Clearance between inner rotor and outer rotor	Factory specification	0.03 to 0.14 mm 0.0012 to 0.0055 in.
	Allowable limit	0.2 mm 0.008 in.

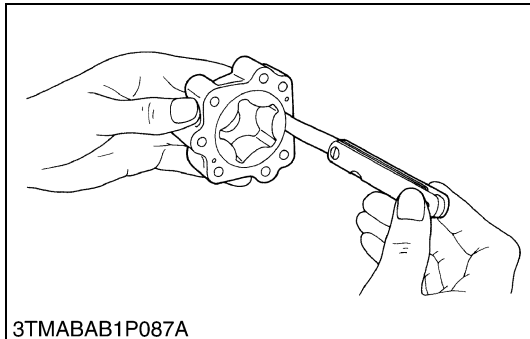

Clearance between outer rotor and pump body	Factory specification	0.11 to 0.19 mm 0.0043 to 0.0075 in.
	Allowable limit	0.25 mm 0.0098 in.

9Y1211109ENS0129US0

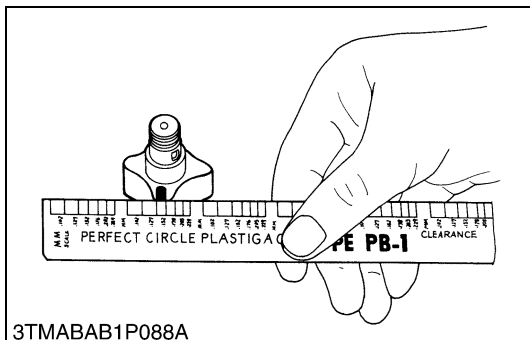

**Clearance between Rotor and Cover**

- Put a strip of plastigauge (Code No. 07909-30241) onto the rotor face with grease.
- Install the cover and tighten the screws.
- Remove the cover carefully, and measure the width of the press gauge with a sheet of gauge.
- If the clearance exceeds the factory specifications, replace the oil pump rotor assembly.

End clearance between inner rotor and cover	Factory specification	0.105 to 0.150 mm 0.00414 to 0.00590 in.
	Allowable limit	0.2 mm 0.0079 in.

9Y1211109ENS0130US0

# 2 CLUTCH

# MECHANISM

## CONTENTS

1. LINKAGE MECHANISM .....	2-M1
----------------------------	------

# 1. LINKAGE MECHANISM

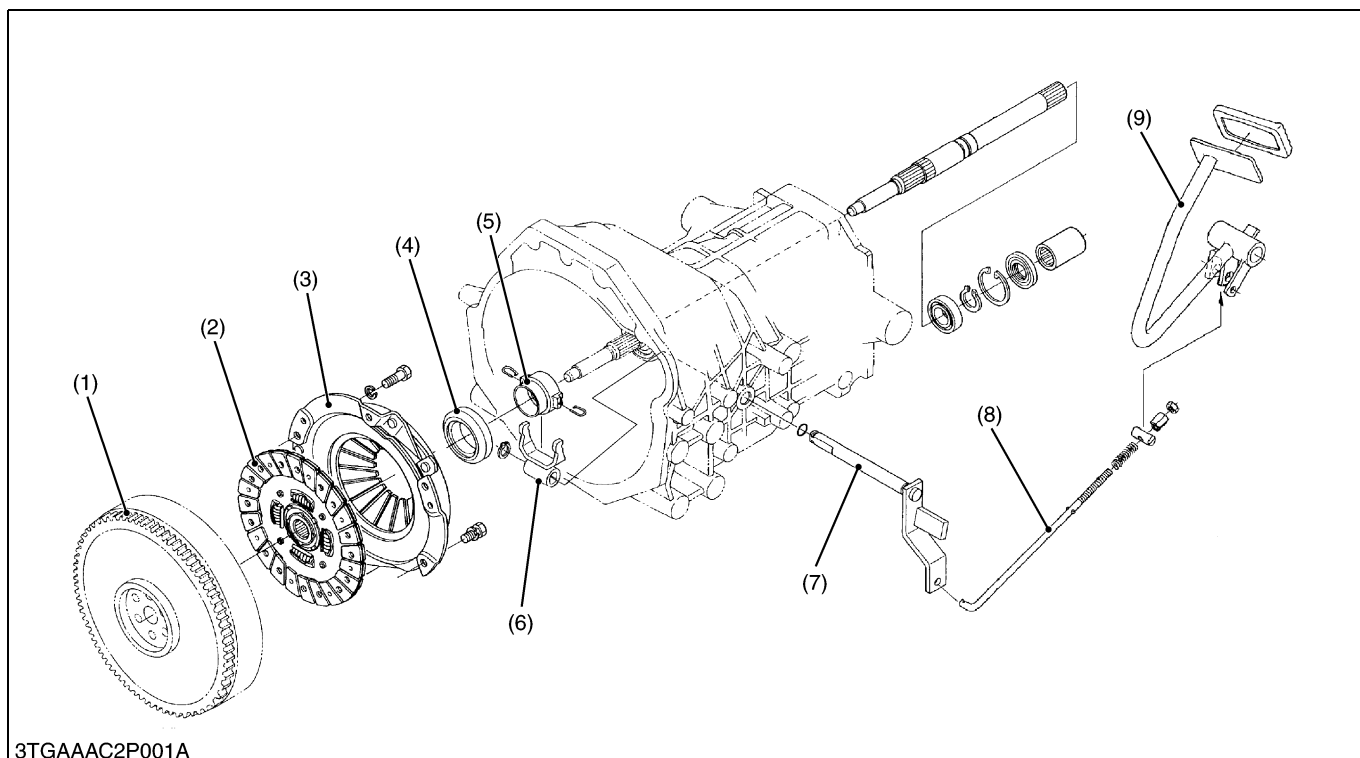

3TGAAAC2P001A

- |                             |                     |                  |                  |
|-----------------------------|---------------------|------------------|------------------|
| (1) Flywheel                | (4) Release Bearing | (6) Release Fork | (8) Clutch Rod   |
| (2) Clutch Disc             | (5) Release Hub     | (7) Clutch Lever | (9) Clutch Pedal |
| (3) Pressure Plate Assembly |                     |                  |                  |

The dry single type clutch is adopted for this tractor.

The clutch is located between the engine and transmission, and is operated by stepping on the clutch pedal. When the clutch pedal is not depressed, the clutch is engaged and power from the engine is transmitted to the transmission.

9Y1211109CLM0001US0



# SERVICING

## CONTENTS

1. TROUBLESHOOTING.....	2-S1
2. SERVICING SPECIFICATIONS.....	2-S2
3. TIGHTENING TORQUES.....	2-S3
4. CHECKING, DISASSEMBLING AND SERVICING.....	2-S4
[1] CHECKING AND ADJUSTING.....	2-S4
[2] PREPARATION.....	2-S5
(1) Separating Engine from Clutch Housing for ROPS.....	2-S5
(2) Separating Engine from Tractor for CABIN.....	2-S14
[3] DISASSEMBLING AND ASSEMBLING.....	2-S30
[4] SERVICING.....	2-S31

# 1. TROUBLESHOOTING

Symptom	Probable Cause and Checking Procedure	Solution	Reference Page
<b>Clutch Drags</b>	1. Clutch pedal free travel is too much.	Adjust the clutch pedal free travel to the factory specification.	2-S4
	2. Dusts generated from the clutch disc facing are attached on the clutch disc.	Clean the dusts on the clutch disc and adjust the clutch pedal free travel to the factory specification.	2-S30
	3. Release fork is damaged.	Replace the release fork.	2-S30
	4. Clutch disc or pressure plate is warped.	Make sure and replace the clutch disc and pressure plate.	2-S30
<b>Clutch Slips</b>	1. Clutch disc is worn excessively.	Replace the clutch disc.	2-S30
	2. Grease or oil is attached on clutch disc facing.	Replace clutch disc with a new one.	2-S30
	3. Clutch disc or pressure plate is warped.	Make sure the clutch disc and the pressure plate with a new one.	2-S30
	4. Diaphragm spring is weaken or broken.	Replace pressure plate assembly.	2-S30
<b>Chattering</b>	1. Grease or oil is attached on clutch disc facing.	Replace clutch disc assembly.	2-S30
	2. Clutch disc or pressure plate is warped.	Replace clutch disc or pressure plate as an assembly.	2-S30
	3. Clutch disc spline boss is worn or rusted.	Replace clutch disc assembly or remove rust.	2-S30
	4. Pressure plate or flywheel face is cracked or scored.	Replace pressure plate assembly or flywheel.	2-S30
	5. Clutch disc spline boss and main shaft spline is worn.	Replace clutch disc assembly or main shaft.	2-S30
	6. Diaphragm spring strength uneven or diaphragm spring is damaged.	Replace pressure plate assembly with a new one.	2-S30
<b>Rattle During Running</b>	1. Clutch disc spline boss is worn.	Replace clutch disc.	2-S30
	2. Release bearing is worn or sticking.	Replace release bearing.	2-S30
<b>Clutch Squeaks</b>	1. Release bearing is sticking or dry.	Replace release bearing.	2-S30
	2. Clutch disc is worn excessively.	Replace clutch disc.	2-S30
<b>Vibration</b>	1. Clutch disc rivet is worn or damaged.	Replace clutch disc.	2-S30
	2. Clutch parts are damaged.	Replace clutch disc and pressure plate.	2-S30

9Y1211109CLS0001US0

## 2. SERVICING SPECIFICATIONS

Item		Factory Specification	Allowable Limit
Clutch Pedal	Free Travel on Clutch Pedal	20 to 30 mm 0.78 to 1.18 in.	–
Clutch Disc	Disc Surface to Rivet Top (Depth)	–	0.3 mm 0.012 in.
Clutch Disc Boss to Gear Shaft	Backlash (Displacement around Disc Edge)	–	2.0 mm 0.079 in.
Pressure Plate	Flatness	–	0.2 mm 0.008 in.
Diaphragm Spring	Mutual Difference	–	0.5 mm 0.020 in.

9Y1211109CLS0002US0

### 3. TIGHTENING TORQUES

Tightening torques of screws, bolts and nuts on the table below are especially specified.  
(For general use screws, bolts and nuts: Refer to "5. TIGHTENING TORQUES" on page G-10.)

Item	N·m	kgf·m	lbf·ft
Steering wheel mounting nut	48.1 to 55.9	4.9 to 5.7	35.4 to 41.2
Delivery hose R.H. retaining nut	24.5 to 29.4	2.5 to 3.0	18.1 to 21.7
Delivery hose L.H. retaining nut	24.5 to 29.4	2.5 to 3.0	18.1 to 21.7
Return hose retaining nut	34.3 to 44.1	3.5 to 4.5	25.3 to 32.5
Delivery hose joint screw	45.1 to 53.0	4.60 to 5.40	33.3 to 39.0
Bi-speed delivery pipe joint screw (pump side)	34.3 to 39.2	3.5 to 4.0	25.3 to 28.9
Bi-speed delivery pipe retaining nut (Bi-speed valve side)	29 to 49	3.0 to 5.0	21.7 to 36.2
Engine mounting screw and nut (M10)	48.1 to 55.9	4.9 to 5.7	35.5 to 41.2
Engine mounting nut (M12)	77.5 to 90.2	7.9 to 9.2	57.2 to 66.5
Rear wheel mounting screw and nut	196.1 to 225.6	20.0 to 23.0	145 to 166
Hydraulic hose <b>PB</b> , <b>P</b> and <b>T</b> retaining nuts	30 to 40	3.1 to 4.0	23 to 29
Outer roof mounting screw	3.5 to 4.0	0.36 to 0.40	2.6 to 2.9
Cabin mounting bolt and nut	124 to 147	12.6 to 15.0	91.1 to 108
Clutch mounting screw	23.5 to 27.5	2.4 to 2.8	17.4 to 20.2

9Y1211109CLS0003US0

# 4. CHECKING, DISASSEMBLING AND SERVICING

## [1] CHECKING AND ADJUSTING

### Checking Clutch Pedal Free Travel

**CAUTION**

- When checking, park the tractor on flat ground, apply the parking brake, stop the engine and remove the key.

- Slightly depress the clutch pedal (1) and measure free travel "L" at top of the clutch pedal.
- If the measurement is not within the factory specification, loosen the lock nut and adjust the clutch rod (2) length.

**IMPORTANT**

- After adjustment, be sure to check the operation of the safety switch (3). The engine should not start if the clutch pedal is not fully depressed. Refer to "Safety Switches" (page 9-S26) in ELECTRICAL SYSTEM section for the safety switch.

Clutch pedal free travel "L" on top of clutch pedal	Factory specification	20 to 30 mm 0.78 to 1.18 in.
--	-----------------------	---------------------------------

- (1) Clutch Pedal **L: Clutch Pedal Free Travel**  
 (2) Clutch Rod  
 (3) Safety Switch (Clutch Pedal Switch)

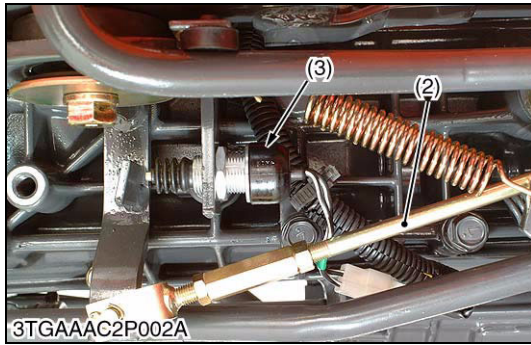
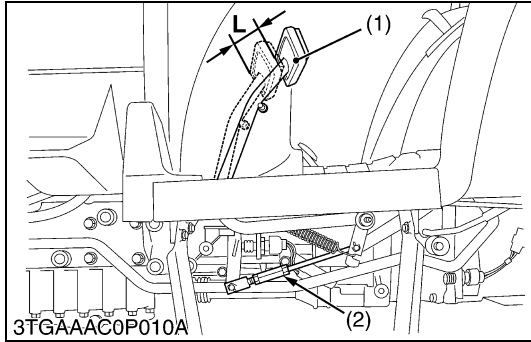

9Y1211109CLS0004US0

## [2] PREPARATION

### (1) Separating Engine from Clutch Housing for ROPS

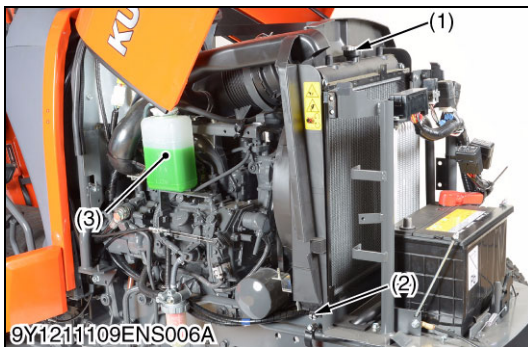
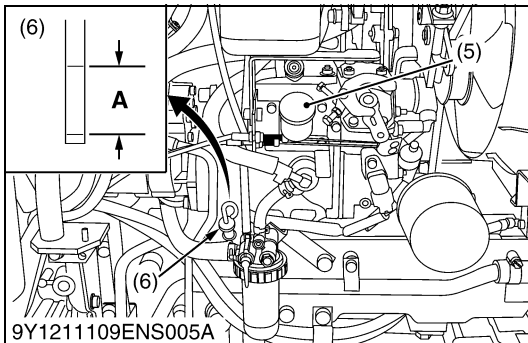
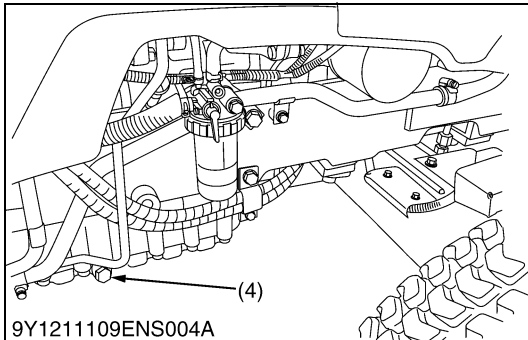
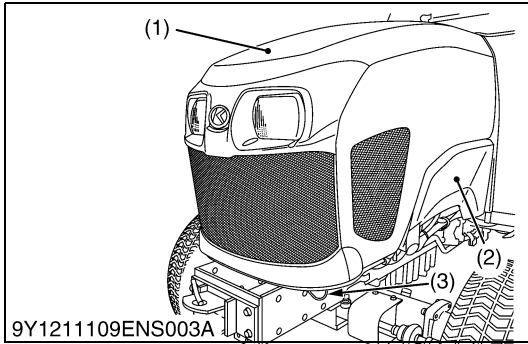

#### Draining Engine Oil

1. Place an oil pan underneath the engine.
2. To open the hood (1), hold the hood (1) and pull the release lever (3) and open the hood (1).
3. Remove the bolt from each of the side covers (2) and remove the side covers (2).
4. To drain the oil, remove the both drain plugs (4) at the bottom of the engine and drain the oil completely into the oil pan.
5. After draining, reinstall the both drain plugs (4).

#### (When reassembling)

- Fill with the new engine oil up to the upper notch on the dipstick (6).

#### ■ IMPORTANT

- When using an oil of different manufacture or viscosity from the previous one, remove all of the old oil.
- Never mix two different types of oil.
- Use the proper SAE Engine Oil according to ambient temperatures.
- Refer to "4. LUBRICANTS, FUEL AND COOLANT" on page G-8.

Engine Oil	Capacity	STW34	5.7 L 6.0 U.S.qts 5.0 Imp.qts
		STW37, STW40	6.7 L 7.1 U.S.qts 5.9 Imp.qts

- |                   |  |
|-------------------|--|
| (1) Hood          | (5) Oil Inlet  |
| (2) Side Cover    | (6) Dipstick   |
| (3) Release Lever | <b>A: Oil level is acceptable within this range.</b> |
| (4) Drain Plug    |  |

9Y1211109ENS0018US0

#### Draining Coolant

#### ⚠ WARNING

To avoid personal injury or death:

- Do not remove the radiator cap while coolant is hot. When cool, slowly rotate cap to the first stop and allow sufficient time for excess pressure to escape before removing the cap completely.

1. Stop the engine and let it cool down.
2. To drain the coolant, open the radiator drain plug (2) and remove radiator cap (1). The radiator cap (1) must be removed to completely drain the coolant.
3. After all coolant is drained, reinstall the drain plug (2).

Coolant (with recovery tank)	Capacity	6.6 L 7.0 U.S.qts 5.8 Imp.qts
------------------------------	----------	-------------------------------------

- |                  |                   |
|------------------|-------------------|
| (1) Radiator Cap | (3) Recovery Tank |
| (2) Drain Plug   |                   |

9Y1211109ENS0019US0

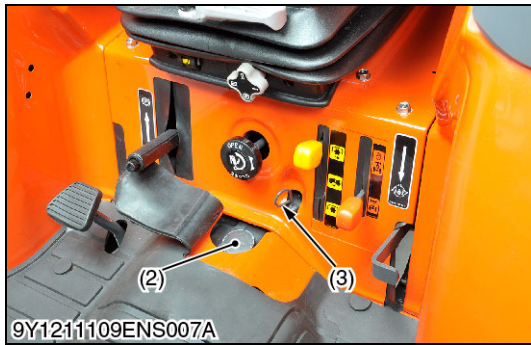
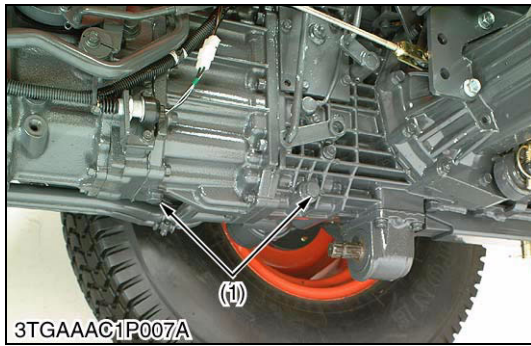

**Draining Transmission Fluid**

1. Place an oil pan underneath the transmission case, and remove the drain plugs (1).
2. Drain the transmission fluid.
3. Reinstall the drain plugs (1).

**(When reassembling)**

- Fill new oil from filling port after removing the filling plug (2) up to the upper notch on the dipstick (3).
- After operating the engine for few minutes, stop it and check the oil level again, if low, add oil prescribed level.

**IMPORTANT**

- Use only KUBOTA SUPER UDT fluid. Use of other oils may damage the transmission or hydraulic system. Refer to "4. LUBRICANTS, FUEL AND COOLANT" on page G-8
- Never work the tractor immediately after changing the transmission oil. Keeping the engine at medium speed for a few minutes to prevents damage to the transmission.
- Do not mix different brands oil together.

Transmission fluid	Capacity	24 L 6.3 U.S.gals 5.3 Imp.gals
--------------------	----------	--------------------------------------

- (1) Drain Plug (3) Dipstick  
(2) Filling Plug

9Y1211109ENS0020US0

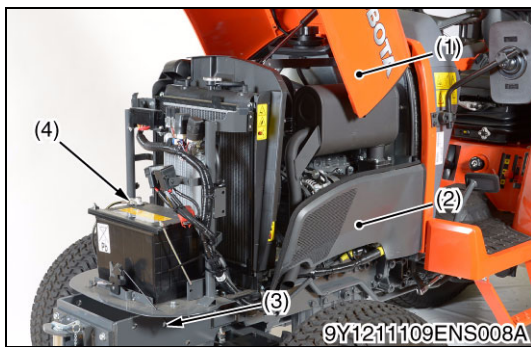

**Hood, Side Cover and Battery Cord**

1. To open the hood (1), hold the hood (1) and pull the release lever (3) and open the hood (1).
2. Remove the bolt from each of the side covers and remove the side covers (2).
3. Disconnect the battery negative cable (4).
4. Disconnect the head light connector (5) and damper (7).
5. Remove the two screws (6), and then remove the hood (1).

**(When reassembling)**

**NOTE**

- When disconnecting the battery cords, disconnect the grounding cord first. When connecting, positive cord first.

- (1) Hood (5) Head Light Connector  
(2) Side Cover (6) Screw  
(3) Release Lever (7) Damper  
(4) Battery Negative Cable

9Y1211109ENS0021US0

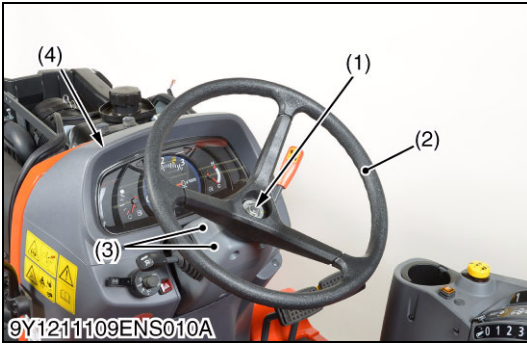

**Steering Wheel and Panel Under Cover**

1. Remove the covers (3).
2. Remove the steering wheel cap.
3. Remove the steering wheel mounting nut (1) and remove the steering wheel (2) with a steering wheel puller (Code No. 07916-51090).
4. Remove the panel cover (4).

**(When reassembling)**

Tightening torque	Steering wheel mounting nut	48.1 to 55.9 N·m 4.9 to 5.7 kgf·m 35.4 to 41.2 lbf·ft
-------------------	-----------------------------	---

- |                    |                 |
|--------------------|-----------------|
| (1) Nut            | (3) Cover       |
| (2) Steering Wheel | (4) Panel Cover |

9Y1211109ENS0022US0



**Instrument Panel**

1. Remove the instrument panel mounting screws and disconnect the instrument panel connector (2). Then remove the instrument panel (1).
2. Disconnect the combination switch connector (6), main switch connector (3) and hazard switch connector (4).
3. Remove the under cover (5).

- |                                |                                  |
|--------------------------------|----------------------------------|
| (1) Instrument Panel           | (4) Hazard Switch Connector      |
| (2) Instrument Panel Connector | (5) Under Cover                  |
| (3) Main Switch Connector      | (6) Combination Switch Connector |

9Y1211109ENS0023US0

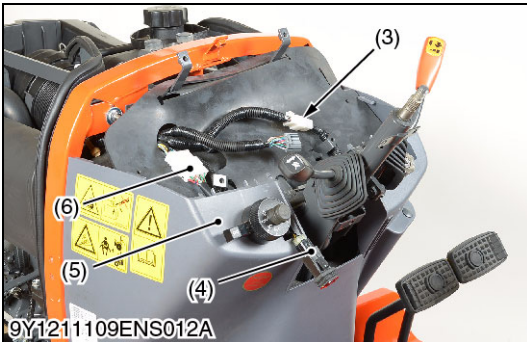



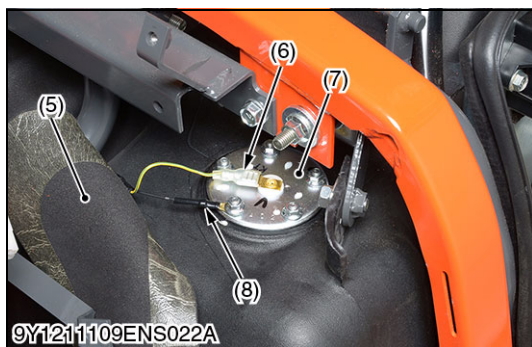
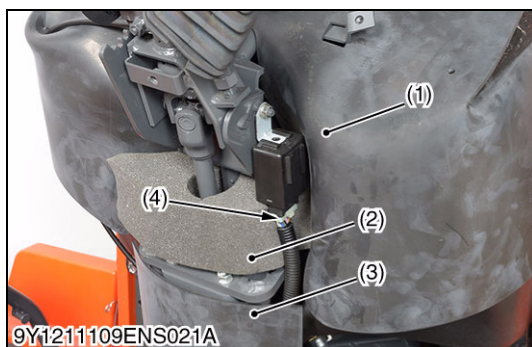
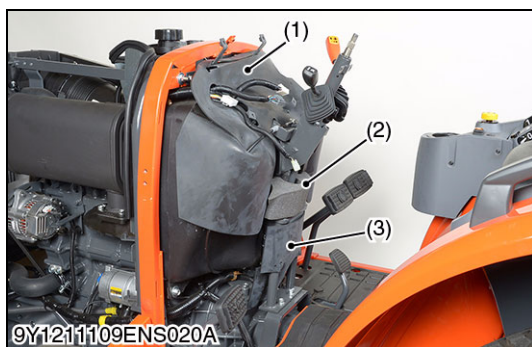

### **Rubber and Wiring Harness**

1. Remove the fuel tank cover (1)
2. Disconnect the OPC controller connector (4).
3. Remove the steering controller cover (3).
4. Remove the sponge (2).
5. Turn over the fuel sensor cover (5), and disconnect the grounding wire (8) and **1P** connector (6) from the fuel level sensor (7).

(1) Fuel Tank Cover

(2) Sponge

(3) Steering Controller Cover

(4) OPC Controller Connector

(5) Fuel Sensor Cover

(6) **1P** Connector

(7) Fuel Sensor

(8) Grounding Wire

9Y1211109ENS0024US0

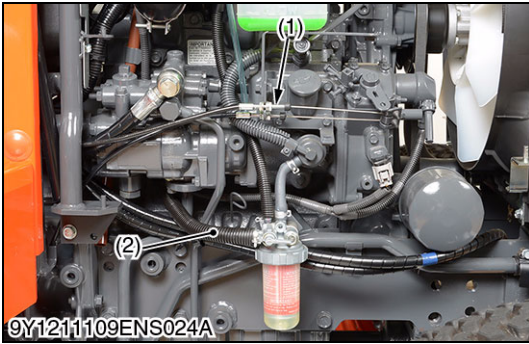

**Power Steering Hoses and Accelerator Wire (Right Side)**

1. Disconnect the accelerator wire (1) from the engine.
2. Disconnect the fuel hose (2).
3. Disconnect the delivery hose L.H. (3) and delivery hose R.H. (4) from the steering controller.
4. Disconnect the power steering delivery hose (6) from the steering controller.
5. Disconnect the power steering return hose (5) from the steering controller.

**(When reassembling)**

- Be sure to connect the each hose to original position.
- Be sure to check the hose joints do not interfere in other joints.

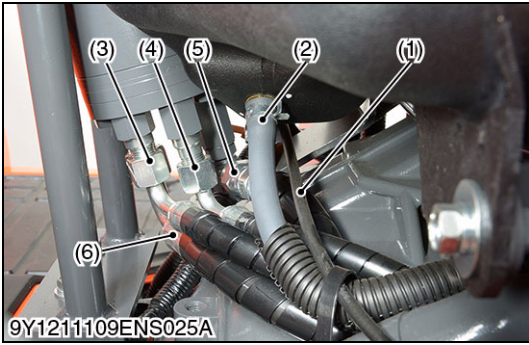

Tightening torque	Delivery hose R.H. (4) retaining nut	24.5 to 29.4 N·m 2.5 to 3.0 kgf·m 18.1 to 21.7 lbf·ft
	Delivery hose L.H. (3) retaining nut	24.5 to 29.4 N·m 2.5 to 3.0 kgf·m 18.1 to 21.7 lbf·ft
	Return hose retaining nut	34.3 to 44.1 N·m 3.5 to 4.5 kgf·m 25.3 to 32.5 lbf·ft
	Delivery hose joint screw	45.1 to 53.0 N·m 4.60 to 5.40 kgf·m 33.3 to 39.0 lbf·ft

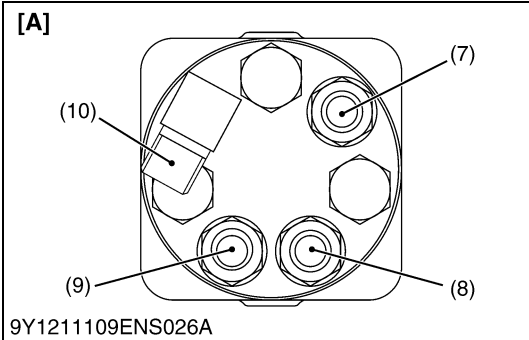

- |                                  |             |
|----------------------------------|-------------|
| (1) Accelerator Wire             | (7) P Port  |
| (2) Fuel Hose                    | (8) LT Port |
| (3) Delivery Hose L.H.           | (9) RT Port |
| (4) Delivery Hose R.H.           | (10) T Port |
| (5) Power Steering Return Hose   |             |
| (6) Power Steering Delivery Hose |             |
- [A] Viewed from Bottom Side**

9Y1211109ENS0028US0

**Steering Support**

1. Remove the screws (1).
2. Remove the screws (4).
3. Remove the steering support (2) with steering controller (3).

- |                      |                         |
|----------------------|-------------------------|
| (1) Screw            | (3) Steering Controller |
| (2) Steering Support | (4) Screw               |

9Y1211109ENS0025US0



**Panel Under Frame**

1. Remove the foot covers (1).
2. Remove the screws (2) and nuts (4), and pull up the panel under frame (3).

- |                |                       |
|----------------|-----------------------|
| (1) Foot Cover | (3) Panel Under Frame |
| (2) Screw      | (4) Nut               |

9Y1211109ENS0030US0



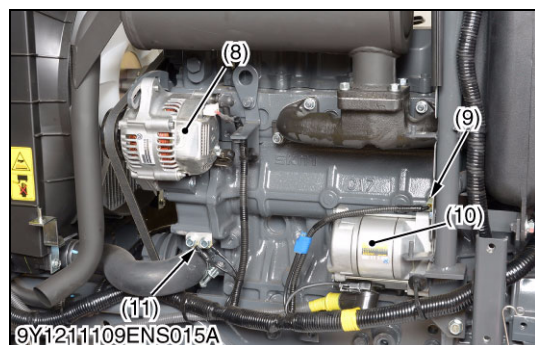
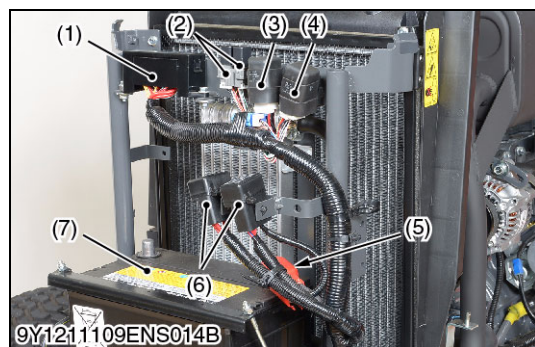

### Wiring Harness (Left Side)

1. Remove the fuse box (1) from the stay.
2. Disconnect the connectors from the relays (2).
3. Remove the glow relay (3).
4. Remove the key stop relay (4).
5. Remove the slow blow fuse boxes (6).
6. Disconnect the battery positive cable (5) from the battery terminal.
7. Remove the battery (7).
8. Disconnect the connectors from the alternator (8), oil switch (9) and stater (10).
9. Disconnect the grounding terminal (11).

- |                            |                         |
|----------------------------|-------------------------|
| (1) Fuse Box               | (6) Slow Blow Fuse      |
| (2) Relay                  | (7) Battery             |
| (3) Glow Relay             | (8) Alternator          |
| (4) Key Stop Relay         | (9) Oil Switch          |
| (5) Battery Positive Cable | (10) Starter            |
|                            | (11) Grounding Terminal |

9Y1211109ENS0026US0

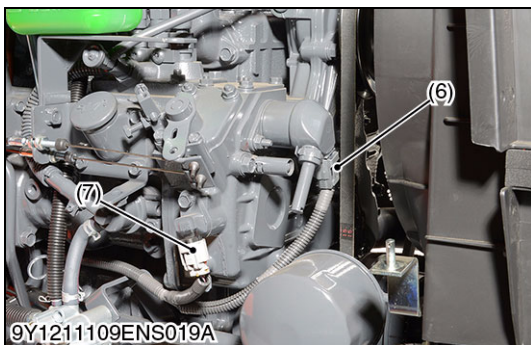
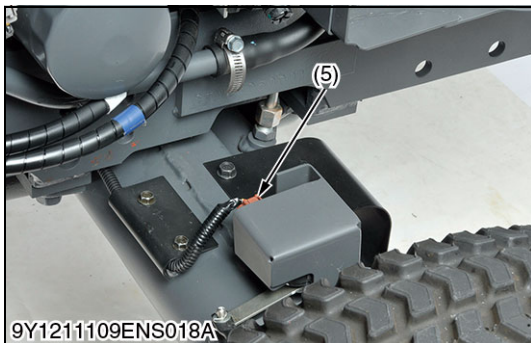
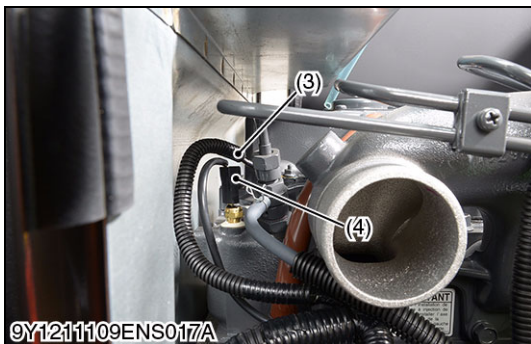
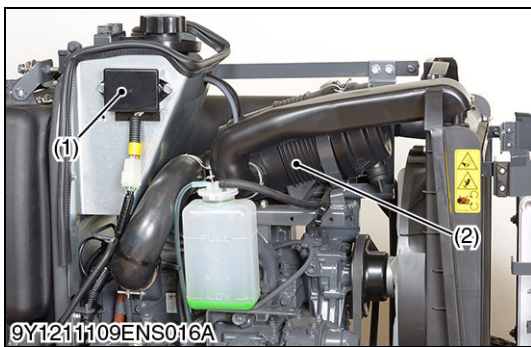

**Wiring Harness (Right Side)**

1. Disconnect the connector from the flasher unit (1).
2. Remove the air cleaner (2).
3. Disconnect the glow plug cable (3).
4. Disconnect the **1P** connector (4) from the coolant temperature sensor.
5. Disconnect the connector from the front wheel angle sensor (5).
6. Disconnect the connector from the key stop solenoid (6).
7. Disconnect the connector from the engine revolution sensor (7).

- |                         |                              |
|-------------------------|------------------------------|
| (1) Flasher Unit        | (5) Front Wheel Angle Sensor |
| (2) Air Cleaner         | (6) Key Stop Solenoid        |
| (3) Glow Plug Cable     | (7) Engine Revolution Sensor |
| (4) <b>1P</b> Connector |                              |

9Y1211109ENS0027US0

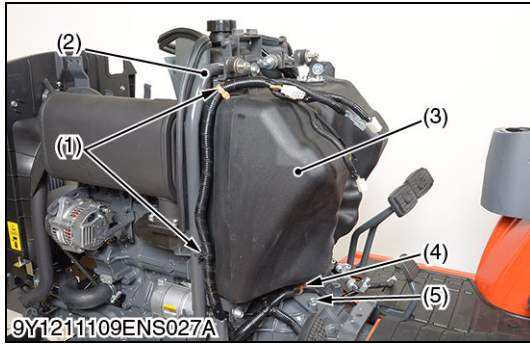

**Fuel Tank**

1. Pull out the clamps (1), (4).
2. Disconnect the overflow hoses from fuel tank (3).
3. Remove the screws (5), (6) and then remove the fuel tank (3) with pillar (2).

- |               |           |
|---------------|-----------|
| (1) Clamp     | (4) Clamp |
| (2) Pillar    | (5) Screw |
| (3) Fuel Tank | (6) Screw |

9Y1211109ENS0029US0

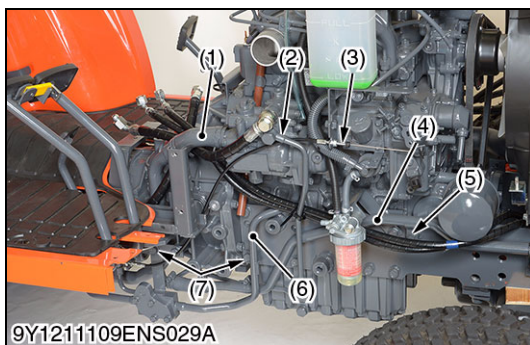
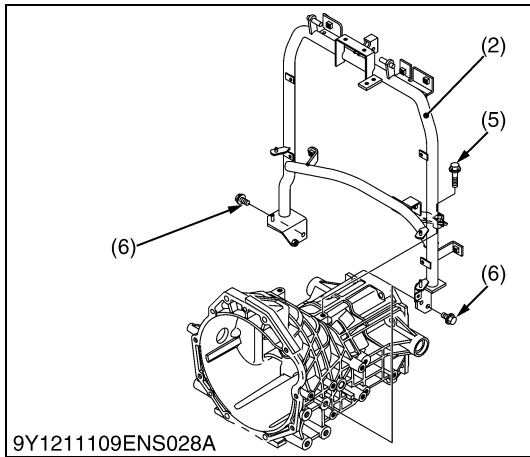

**Hydraulic Pipe and Hose**

1. Disconnect the suction hose (3) from the engine.
2. Remove the retaining screws (7) and separate the **3P** hydraulic delivery pipe (6) from the hydraulic pump.
3. Disconnect the bi-speed delivery pipe (2) from the hydraulic pump.
4. Disconnect the oil cooler inlet hose (9) and outlet hose (8).
5. Remove the retaining screws (5), (10) and then disconnect the oil cooler pipe (4).
6. Disconnect the suction hose (1).



Tightening torque	Bi-speed delivery pipe joint screw (Pump side)	30 to 40 N·m 3.1 to 4.0 kgf·m 23 to 29 lbf·ft
	Bi-speed delivery pipe retaining nut (Bi-speed valve side)	29 to 49 N·m 3.0 to 5.0 kgf·m 21.7 to 36.2 lbf·ft

- |                            |                                       |
|----------------------------|---------------------------------------|
| (1) Suction Hose           | (6) <b>3P</b> Hydraulic Delivery Pipe |
| (2) Bi-speed Delivery Pipe | (7) Retaining Screw                   |
| (3) Accelerator Wire       | (8) Oil Cooler Outlet Hose            |
| (4) Oil Cooler Pipe        | (9) Oil Cooler Inlet Hose             |
| (5) Retaining Screw        | (10) Retaining Screw                  |

9Y1211109ENS0031US0

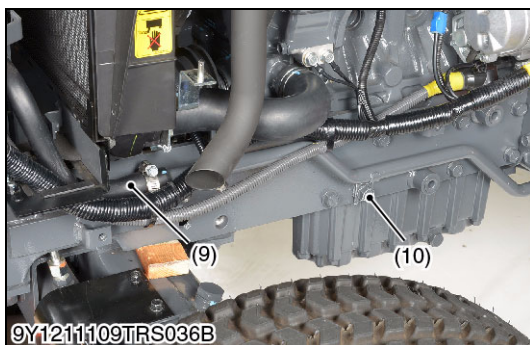

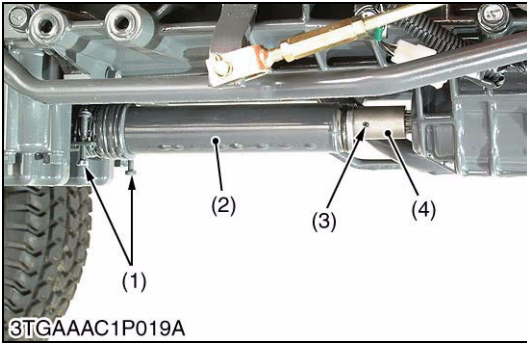

**Propeller Shaft**

1. Loosen the clamp screws (1) and slide the propeller shaft cover (2).
2. Tap out the spring pin (3) and then slide the coupling (4).
3. Remove the propeller shaft with the cover.

**(When reassembling)**

- Apply grease to the spline portion of the propeller shaft and couplings.
- When inserting the spring pins (3), face their splits in the direction parallel to the propeller shaft.
- Tighten the clamp screws (1) upward from the bottom side.

- |                           |                |
|---------------------------|----------------|
| (1) Clamp Screw           | (3) Spring Pin |
| (2) Propeller Shaft Cover | (4) Coupling   |

9Y1211109ENS0032US0



**Separating the Engine from Clutch Housing**

1. Place the disassembling stands under the clutch housing and engine oil pan.
2. Remove the starter.
3. Remove the engine mounting screws and nuts, and separate the engine from the clutch housing.

**(When reassembling)**

- Apply liquid gasket (Three Bond 1211 or equivalent) to joint face of the starter and rear end plate.
- Apply liquid gasket (Three Bond 1206C or equivalent) to joint face of the engine and clutch housing.

Tightening torque	Engine mounting screw, bolt and nut (M10)	48.1 to 55.9 N·m 4.9 to 5.7 kgf·m 35.5 to 41.2 lbf·ft
	Engine mounting nut (M12)	77.5 to 90.2 N·m 7.9 to 9.2 kgf·m 57.2 to 66.5 lbf·ft

9Y1211109ENS0033US0

## (2) Separating Engine from Tractor for CABIN

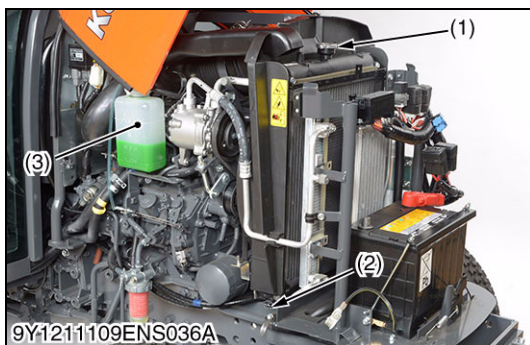
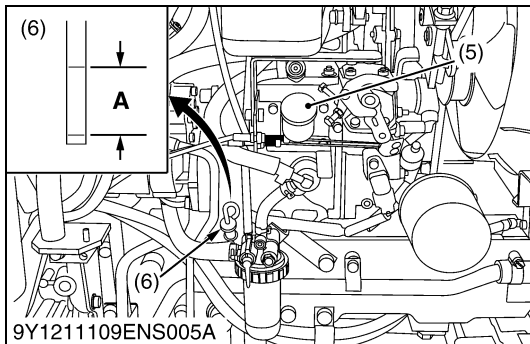
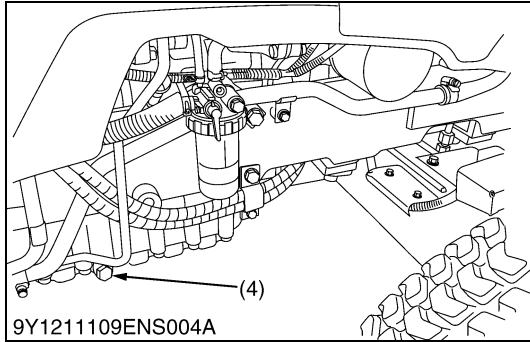
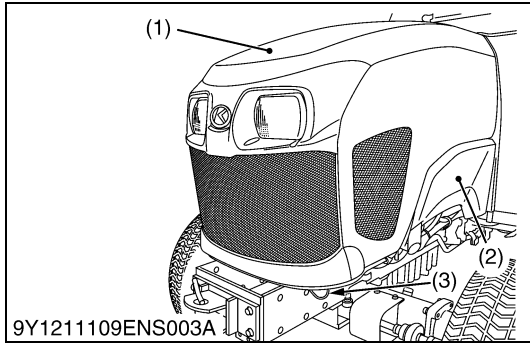

### Draining Engine Oil

1. Place an oil pan underneath the engine.
2. To open the hood (1), hold the hood (1) and pull the release lever (3) and open the hood (1).
3. Remove the bolt from each of the side covers (2) and remove the side covers (2).
4. To drain the oil, remove the both drain plugs (4) at the bottom of the engine and drain the oil completely into the oil pan.
5. After draining, reinstall the both drain plugs (4).

### (When reassembling)

- Fill with the new engine oil up to the upper notch on the dipstick (6).

### ■ IMPORTANT

- When using an oil of different manufacture or viscosity from the previous one, remove all of the old oil.
- Never mix two different types of oil.
- Use the proper SAE Engine Oil according to ambient temperatures.
- Refer to "4. LUBRICANTS, FUEL AND COOLANT" on page G-8.

Engine Oil	Capacity	STW34	5.7 L 6.0 U.S.qts 5.0 Imp.qts
		STW37, STW40	6.7 L 7.1 U.S.qts 5.9 Imp.qts

- (1) Hood
- (2) Side Cover
- (3) Release Lever
- (4) Drain Plug

- (5) Oil Inlet
- (6) Dipstick

**A: Oil level is acceptable within this range.**

9Y1211109ENS0018US0

### Draining Coolant

#### ⚠ WARNING

To avoid personal injury or death:

- Do not remove the radiator cap while coolant is hot. When cool, slowly rotate cap to the first stop and allow sufficient time for excess pressure to escape before removing the cap completely.

1. Stop the engine and let it cool down.
2. To drain the coolant, open the radiator drain plug (2) and remove radiator cap (1). The radiator cap (1) must be removed to completely drain the coolant.
3. After all coolant is drained, reinstall the drain plug (2).

Coolant (with recovery tank)	Capacity	7.1 L 7.5 U.S.qts 6.2 Imp.qts
------------------------------	----------	-------------------------------------

- (1) Radiator Cap
- (2) Drain Plug

- (3) Recovery Tank

9Y1211109ENS0036US0

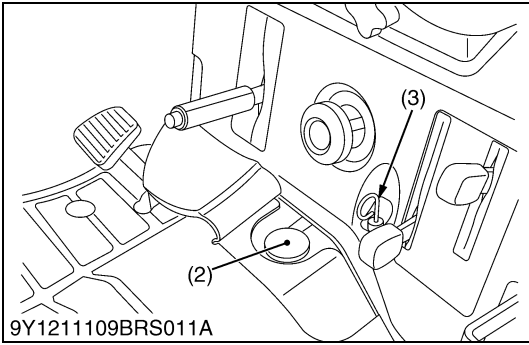
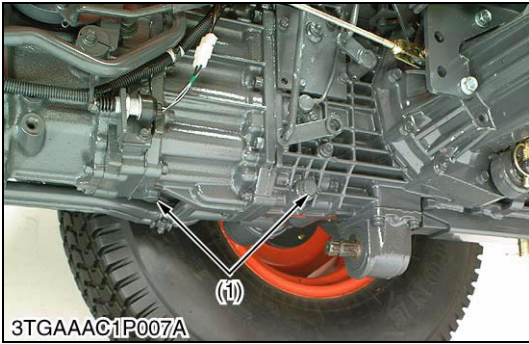

**Draining Transmission Fluid**

1. Place an oil pan underneath the transmission case, and remove the drain plugs (1).
2. Drain the transmission fluid.
3. Reinstall the drain plugs (1).

**(When reassembling)**

- Fill new oil from filling port after removing the filling plug (2) up to the upper notch on the dipstick (3).
- After running the engine for few minutes, stop it and check the oil level again, if low, add oil prescribed level.

**■ IMPORTANT**

- **Use only KUBOTA SUPER UDT fluid. Use of other oils may damage the transmission or hydraulic system. Refer to "4. LUBRICANTS, FUEL AND COOLANT" on page G-8.**
- **Never work the tractor immediately after changing the transmission oil. Keeping the engine at medium speed for a few minutes to prevents damage to the transmission.**
- **Do not mix different brands oil together.**

Transmission fluid	Capacity	24 L 6.3 U.S.gals 5.3 Imp.gals
--------------------	----------	--------------------------------------

- (1) Drain Plug (3) Dipstick  
(2) Filling Plug

9Y1211109ENS0131US0



**Rear Wheel and 3-Point Linkage**

1. Place the disassembling stand under the transmission case.
2. Remove the rear wheels (1).
3. Remove the top link (2), lift rods (3) and lower links (4).
4. Remove the drawbar (5).

Tightening torque	Rear wheel mounting screw and nut	196.1 to 225.6 N·m 20.0 to 23.0 kgf·m 145 to 166 lbf·ft
-------------------	-----------------------------------	---

- (1) Rear Wheel (4) Lower Link  
(2) Top Link (5) Drawbar  
(3) Lift Rod

9Y1211109ENS0037US0



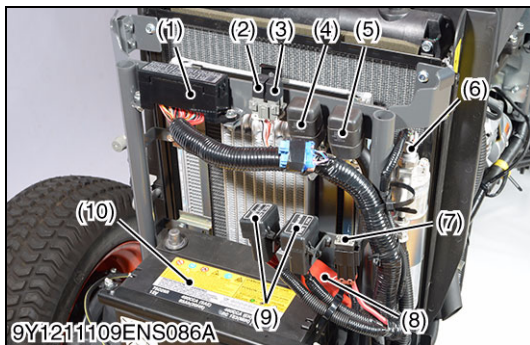
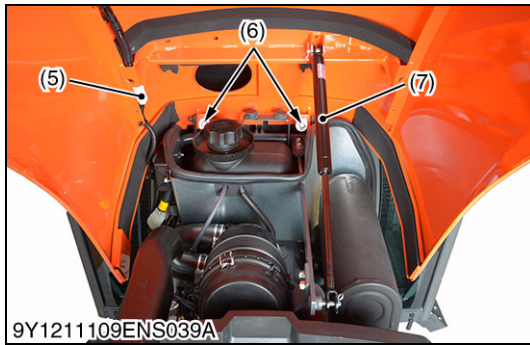
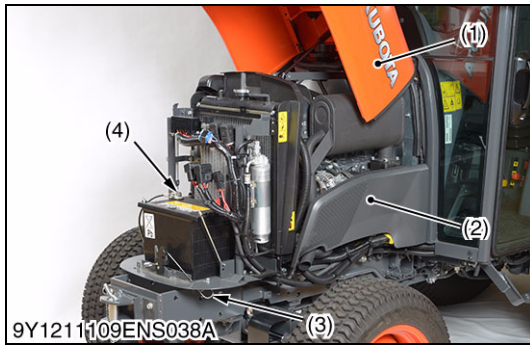

**Hood, Side Cover and Battery Cord**

1. To open the hood (1), hold the hood (1) and pull the release lever (3) and open the hood (1).
2. Remove the bolt from each of the side covers (2) and remove the side covers (2).
3. Disconnect the battery negative cable (4).
4. Disconnect the head light connector (5) and damper (7).
5. Remove the two screws (6) and then remove the hood (1).

**(When reassembling)**

■ **NOTE**

- **When disconnecting the battery cords, disconnect the grounding cord first. When connecting, positive cord first.**

- |                            |                          |
|----------------------------|--------------------------|
| (1) Hood                   | (5) Head Light Connector |
| (2) Side Cover             | (6) Screw                |
| (3) Release Lever          | (7) Damper               |
| (4) Battery Negative Cable |                          |

9Y1211109ENS0038US0

**Wiring Harness**

1. Remove the slow blow fuses (7), (9).
2. Disconnect the battery positive cable (8) from the battery (10).
3. Remove the fuse box (1).
4. Disconnect the relays (2), (3).
5. Remove the electrical outlet relay (4).
6. Remove the key stop relay (5).
7. Disconnect the pressure switch (6).
8. Remove the battery (10).

- |                             |                                 |
|-----------------------------|---------------------------------|
| (1) Fuse Box                | (6) Pressure Switch             |
| (2) Head Light Relay        | (7) Slow Blow Fuse For Defogger |
| (3) Flasher Relay           | (8) Battery Positive Cable      |
| (4) Electrical Outlet Relay | (9) Slow Blow Fuse              |
| (5) Key Stop Relay          | (10) Battery                    |

9Y1211109ENS0132US0

**Steering Wheel**

1. Remove the covers (3).
2. Remove the steering wheel cap.
3. Remove the steering wheel mounting nut (1) and remove the steering wheel (2) with a steering wheel puller (Code No. 07916-51090).

**(When reassembling)**

Tightening torque	Steering wheel mounting nut	48.1 to 55.9 N·m 4.9 to 5.7 kgf·m 35.4 to 41.2 lbf·ft
-------------------	-----------------------------	---

- |                                 |           |
|---------------------------------|-----------|
| (1) Steering Wheel Mounting Nut | (3) Cover |
| (2) Steering Wheel              |           |

9Y1211109ENS0039US0

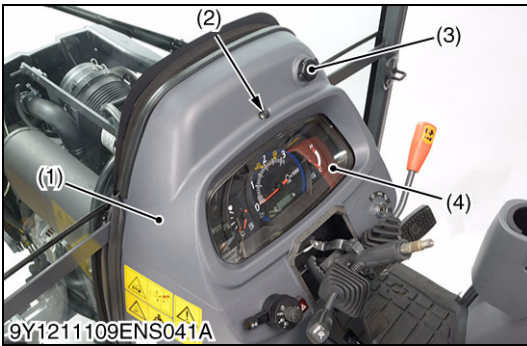

**Instrument Panel and Panel Under Cover**

1. Remove the screw (2).
2. Open the panel cover (1) and disconnect the electrical outlet connector (5).
3. Open the instrument panel (4) and disconnect the instrument panel connector (6). Then remove the instrument panel (4).

- |                       |                                 |
|-----------------------|---------------------------------|
| (1) Panel Cover       | (4) Instrument Panel            |
| (2) Screw             | (5) Electrical Outlet Connector |
| (3) Electrical Outlet | (6) Instrument Panel Connector  |

9Y1211109ENS0040US0

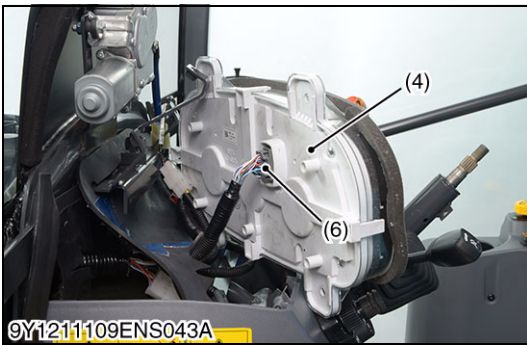
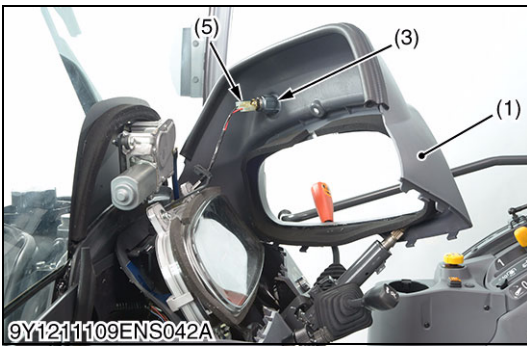

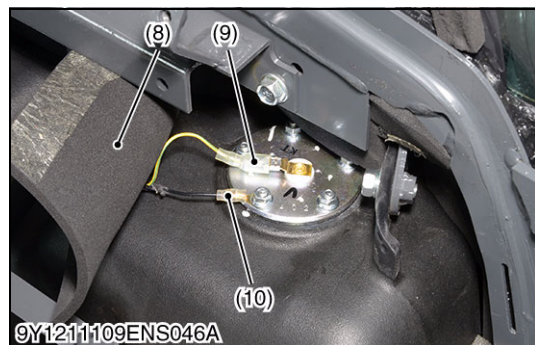
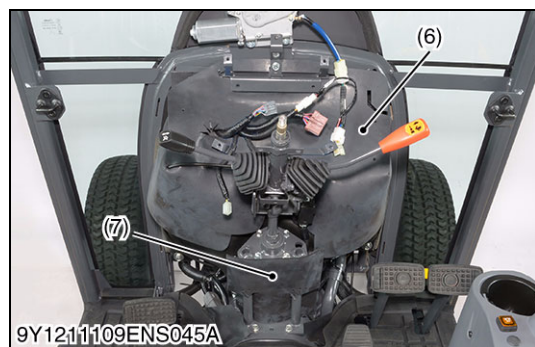
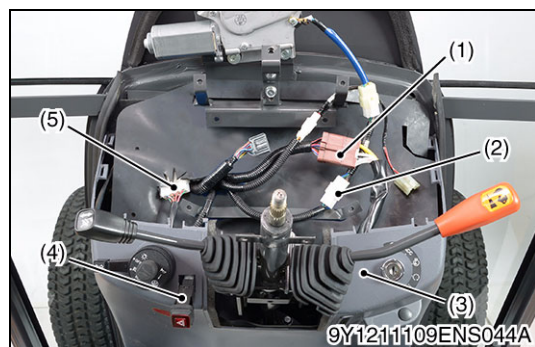

### Wiring Harness

1. Disconnect the combination switch connector (5), main switch connector (1), hazard switch connector (4) and wiper motor connector (2).
2. Remove the panel under cover (3).
3. Remove the rubbers (6), (7).
4. Turn over the fuel level sensor cover (8).
5. Disconnect the grounding wire (10) and **1P** connector (9) from the fuel level sensor.

- |                                  |                             |
|----------------------------------|-----------------------------|
| (1) Main Switch Connector        | (6) Rubber                  |
| (2) Wiper Motor Connector        | (7) Rubber                  |
| (3) Panel Under Cover            | (8) Fuel Level Sensor Cover |
| (4) Hazard Switch Connector      | (9) <b>1P</b> Connector     |
| (5) Combination Switch Connector | (10) Grounding Wire         |

9Y1211109ENS0041US0

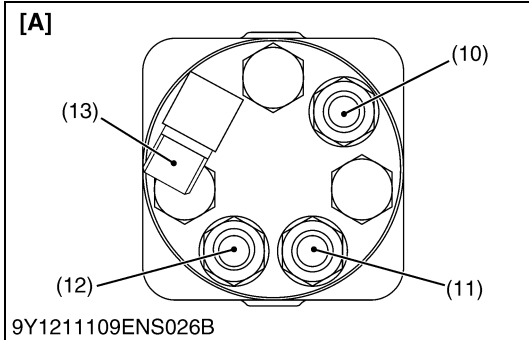
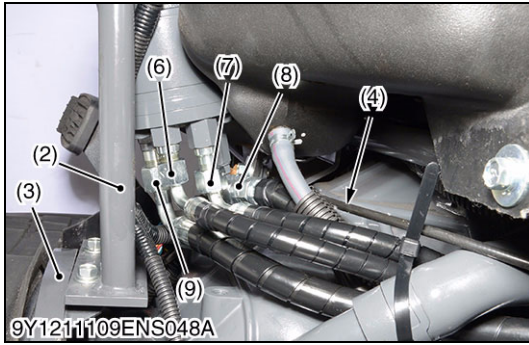
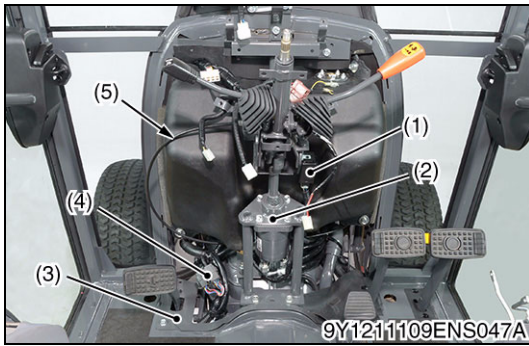

**Power Steering Hoses and Steering Support**

1. Disconnect the accelerator wire (5) from the engine.
2. Disconnect the OPC controller connector (1) and CABIN joint connectors (4).
3. Remove the step cover (3).
4. Disconnect the delivery hose L.H. (6) and delivery hose R.H. (7) from the steering controller.
5. Disconnect the power steering delivery hose (9) from the steering controller.
6. Disconnect the power steering return hose (8) from the steering controller.
7. Remove the steering support (2) with the steering controller.

**(When reassembling)**

- Be sure to connect the each hose to original position.
- Be sure to check the hose joints do not interfere in other joints.

Tightening torque	Delivery hose R.H. (4) retaining nut	24.5 to 29.4 N·m 2.5 to 3.0 kgf·m 18.1 to 21.7 lbf·ft
	Delivery hose L.H. (3) retaining nut	24.5 to 29.4 N·m 2.5 to 3.0 kgf·m 18.1 to 21.7 lbf·ft
	Return hose retaining nut	34.3 to 44.1 N·m 3.5 to 4.5 kgf·m 25.3 to 32.5 lbf·ft
	Delivery hose joint screw	45.1 to 53.0 N·m 4.60 to 5.40 kgf·m 33.3 to 39.0 lbf·ft

- |                              |                                  |
|------------------------------|----------------------------------|
| (1) OPC Controller Connector | (8) Power Steering Return Hose   |
| (2) Steering Support         | (9) Power Steering Delivery Hose |
| (3) Step Cover               | (10) P Port                      |
| (4) CABIN Joint Connector    | (11) LT Port                     |
| (5) Accelerator Wire         | (12) RT Port                     |
| (6) Delivery Hose L.H.       | (13) T Port                      |
| (7) Delivery Hose R.H.       |                                  |
- [A] Viewed from Bottom Side**

9Y1211109ENS0042US0

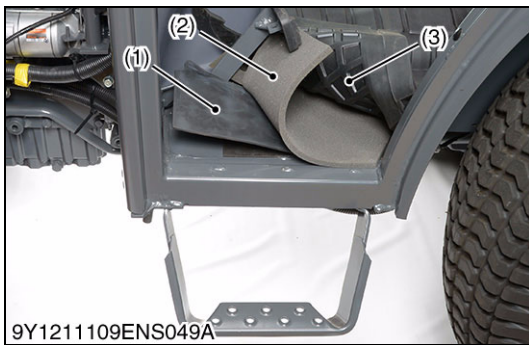

**Step Mat and Seat Under Cover**

1. Remove the step mat (3), sound absorber (2) and rubber (1).
2. Remove the grips of the mid PTO lever (7) and front wheel drive lever (8).
3. Remove the dipstick (6).
4. Remove the lowering speed adjusting knob (5).
5. Remove the seat under cover (4).

**(When reassembling)**

- Do not confuse the grips.
  - Grip (yellow) for the mid PTO lever (7).
  - Grip (red) for the front wheel drive lever (8).

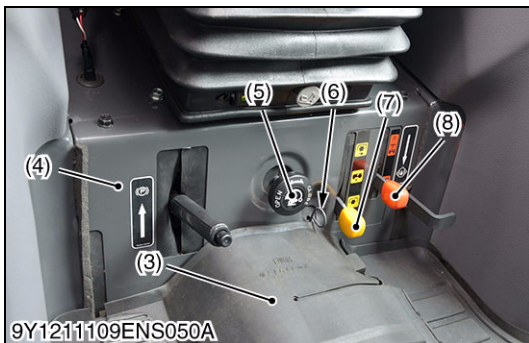

- |                      |                                   |
|----------------------|-----------------------------------|
| (1) Rubber           | (5) Lowering Speed Adjusting Knob |
| (2) Sound Absorber   | (6) Dipstick                      |
| (3) Step Mat         | (7) Mid PTO Lever                 |
| (4) Seat Under Cover | (8) Front Wheel Drive Lever       |

9Y1211109ENS0043US0

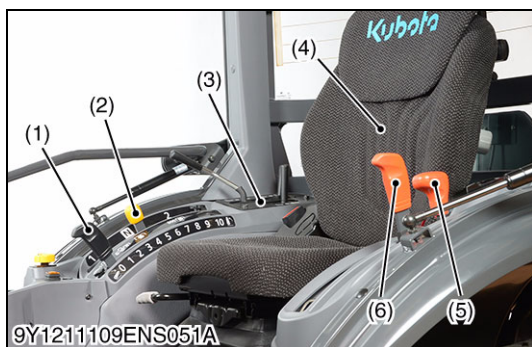

### Seat and Lever Grip

1. Disconnect the seat switch connector (7) and remove the seat (4).
2. Remove the grips of the rear PTO shift lever (2), position control lever (1), cruise control lever (5) and range gear shift lever (6).
3. Remove the remote control lever guide (3).

#### (When reassembling)

- Do not confuse the grips.
  - Grip (yellow) for the rear PTO shift lever (2).
  - Grip (red) for the range gear shift lever (6).

- |                                 |                                 |
|---------------------------------|---------------------------------|
| (1) Position Control Lever Grip | (5) Cruise Control Lever Grip   |
| (2) Rear PTO Shift Lever Grip   | (6) Range Gear Shift Lever Grip |
| (3) Remote Control Lever Guide  | (7) Seat Switch Connector       |
| (4) Seat                        |                                 |

9Y1211109ENS0044US0



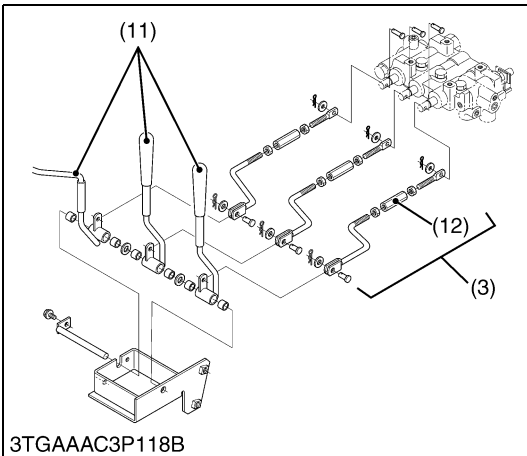
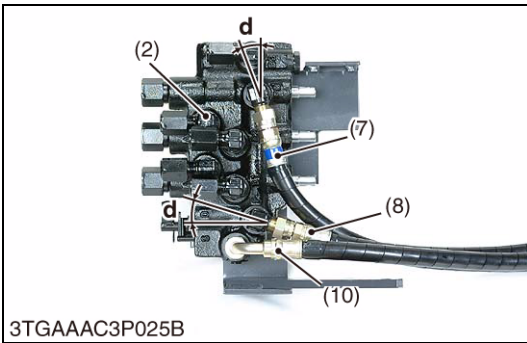
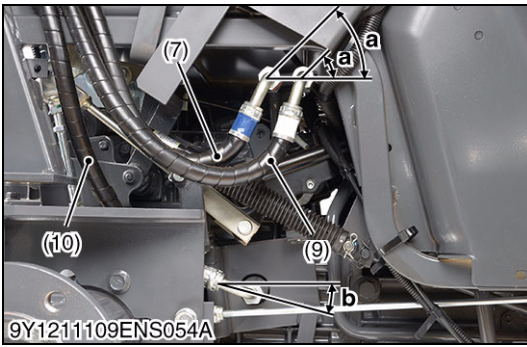
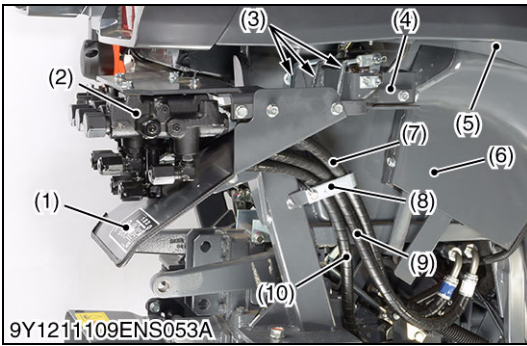

**Auxiliary Control Valve and Covers**

1. Remove the valve cover (1).
2. Remove the valve stay (4).
3. Remove the connecting rods (3).

**(When reassembling)**

- Reassemble the connecting rods (3) as shown in the figure.
- After reassembling the valve stay (4), adjust to locate the control lever (11) at a central position of the guide slot with the turnbuckle (12).

4. Remove the hose clamp (8).

**(When reassembling)**

- Clamp the hydraulic hoses in order of hydraulic hose **PB** (7), hydraulic hose **P** (9) and hydraulic hose **T** (10) from the front side.
5. Disconnect the hydraulic hoses (7), (9), (10) from the tractor body.
  6. Remove the auxiliary control valve (2) with the hydraulic hoses (7), (9), (10).
  7. Remove the remote control lever bracket with the remote control lever (11).

**(When reassembling)**

- Assemble the hose joints to appropriate positions referring to the table below.

8. Remove the fender under cover (5) and fender cover (6).

**(Distinction and installation angle of the hose joints)**

Hydraulic Hose	Hose Joint (Valve side)	Hose Joint (Tractor body side)
<b>P</b> (9)	Straight joint 0.26 rad (15 °)	Bent joint with white tape 0.785 rad (45 °)
<b>PB</b> (7)	Straight joint with blue tape 0.26 rad (15 °)	Bent joint with blue tape 0.785 rad (45 °)
<b>T</b> (10)	Bent joint 1.57 rad (90 °)	Bent joint 0.349 to 0.523 rad (20 to 30 °)
Tightening torque	Hydraulic hose <b>PB</b> , <b>P</b> and <b>T</b> retaining nuts	30 to 40 N·m 3.1 to 4.0 kgf·m 23 to 29 lbf·ft

- |   |   |
|---|---|
| <ol style="list-style-type: none"> <li>(1) Valve Cover</li> <li>(2) Auxiliary Control Valve</li> <li>(3) Connecting Rod</li> <li>(4) Valve Stay</li> <li>(5) Fender Under Cover</li> <li>(6) Fender Cover</li> <li>(7) Hydraulic Hose <b>PB</b></li> <li>(8) Hose Clamp</li> <li>(9) Hydraulic Hose <b>P</b></li> </ol> | <ol style="list-style-type: none"> <li>(10) Hydraulic Hose <b>T</b></li> <li>(11) Remote Control Lever</li> <li>(12) Turnbuckle</li> </ol> <p> <b>a: 0.785 rad (45 °)</b><br/> <b>b: 0.349 to 0.523 rad (20 to 30 °)</b><br/> <b>c: 0.26 rad (15 °)</b><br/> <b>d: 0.26 rad (15 °)</b> </p> |
|---|---|

9Y1211109ENS0045US0



**Fender Assembly**

1. Remove the fender cover (1).
2. Remove the sponges (4), (5).

**(When reassembling)**

- Assemble the sponge (center) (4) between the cruise control lever (2) and range gear shift lever (6).

- |                          |                            |
|--------------------------|----------------------------|
| (1) Fender Cover         | (4) Sponge (Center)        |
| (2) Cruise Control Lever | (5) Sponge (Outer)         |
| (3) Sponge (Inner)       | (6) Range Gear Shift Lever |

9Y1211109ENS0046US0

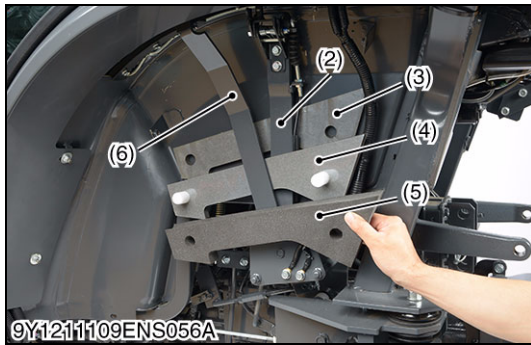

**Release Wire and Wiring Harness (Left Side)**

1. Remove the fender under cover (1).
2. Remove the release wire (3).
3. Remove the lever guide mounting screws (2), and then open the lever guide (4).
4. Disconnect the wiring connectors for the bi-speed controller connectors (5) and electrical outlet connector (6).
5. Remove the lever guide (4) with bi-speed controller.

- |                                   |                                   |
|-----------------------------------|-----------------------------------|
| (1) Fender Under Cover            | (4) Lever Guide                   |
| (2) Lever Guide Mounting Screw    | (5) Bi-speed Controller Connector |
| (3) Release Wire (Cruise Control) | (6) Electrical Outlet Connector   |

9Y1211109ENS0047US0

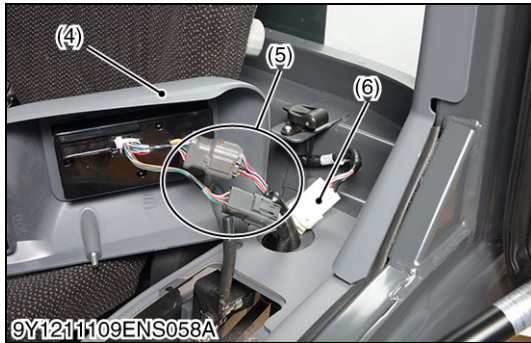
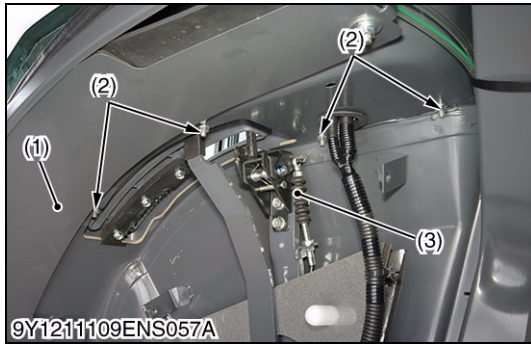



**Wiring Harness (Right Side)**

1. Remove the loader lever guide mounting screws (1).
2. Open the loader lever guide (2) and then disconnect the connectors for PTO switch (4) and beacon switch (3).

- |                                       |                   |
|---------------------------------------|-------------------|
| (1) Loader Lever Guide Mounting Screw | (3) Beacon Switch |
| (2) Loader Lever Guide                | (4) PTO Switch    |

9Y1211109ENS0049US0



**Wiring Harness**

1. Pull down the grommet (1) for seat switch connector.
2. Remove the clamp (2).

- |             |           |
|-------------|-----------|
| (1) Grommet | (2) Clamp |
|-------------|-----------|

9Y1211109ENS0050US0

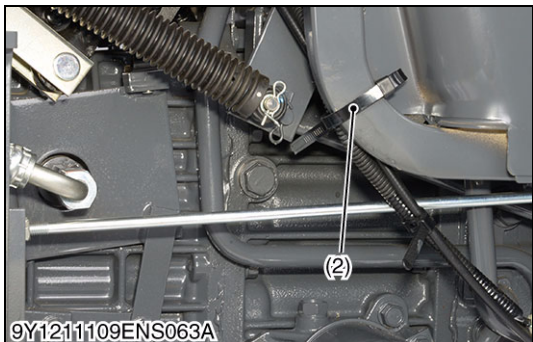
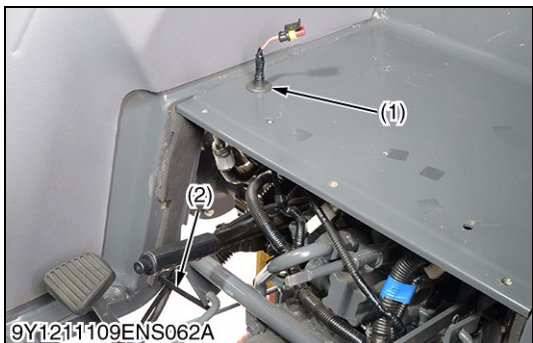



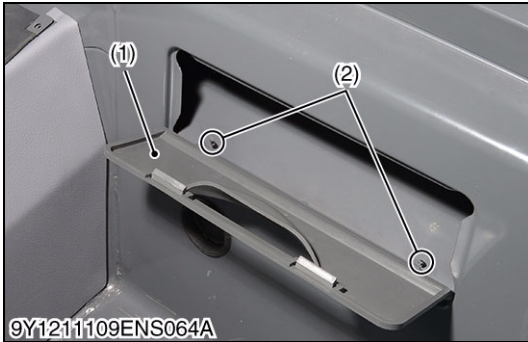

### Wiring Harness (Rear Side)

1. Open the tool box (1).
2. Remove the clamps (2), (3) from the Cabin.
3. Disconnect the registration lamp connectors (4).
4. Disconnect the washer motor connectors (5).
5. Disconnect the PTO switch connector (6).

#### (When reassembling)

- Do not confuse the connectors.
  - Connector (white) for the front washer motor.
  - Connector (gray) for the rear washer motor.

- |              |                                 |
|--------------|---------------------------------|
| (1) Tool Box | (4) Registration Lamp Connector |
| (2) Clamp    | (5) Washer Motor Connector      |
| (3) Clamp    | (6) PTO Switch Connector        |

9Y1211109ENS0051US0

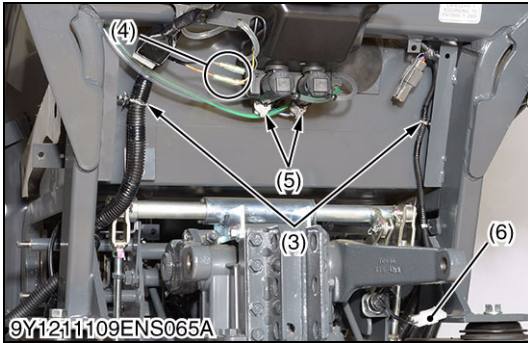

### Differential Lock Pedal and Levers

1. Remove the differential lock pedal (1) with the spring (2).
2. Remove the grounding cable (6) mounting screws.
3. Remove the plate (3).
4. Remove the range gear shift lever (4) and cruise control lever (5).

- |                             |                            |
|-----------------------------|----------------------------|
| (1) Differential Lock Pedal | (4) Range Gear Shift Lever |
| (2) Spring                  | (5) Cruise Control Lever   |
| (3) Plate                   | (6) Grounding Cable        |

9Y1211109ENS0048US0

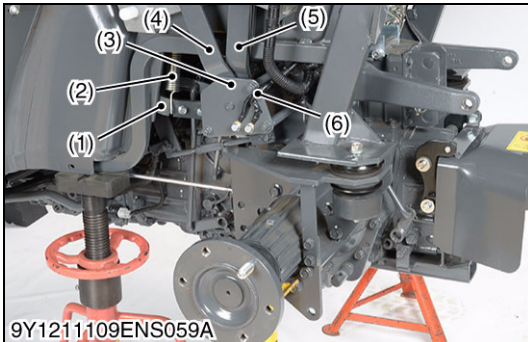

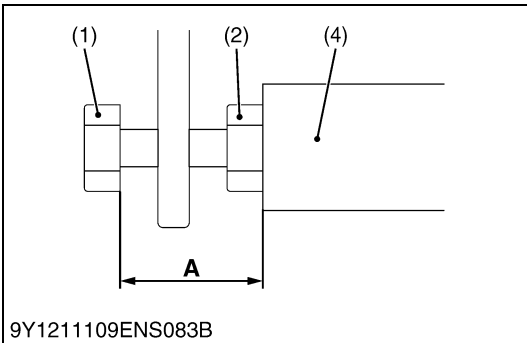
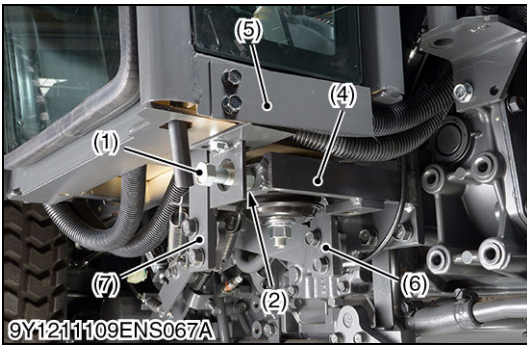
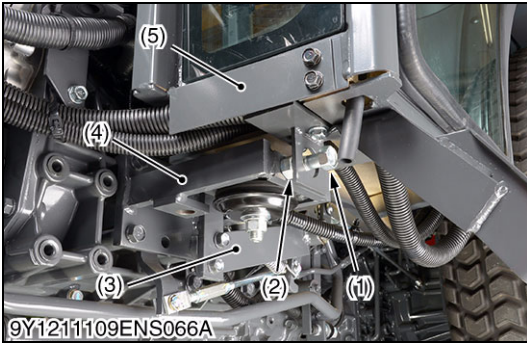

**Clutch Pedal, Brake Pedal and Cabin Stopper Bolt**

1. Remove the both sides of hose plate (5).
2. Remove the clutch pedal (3).
3. Remove the brake pedal L.H. (6) and R.H. (7)
4. Loosen the both sides of lock nut (2), and then remove the both sides of stopper bolt (1)

**(When reassembling)**

- Be sure to install the stopper bolt to the original positions.

- |                   |  |
|-------------------|--|
| (1) Stopper Bolt  | (5) Hose Plate                         |
| (2) Lock Nut      | (6) Brake Pedal L.H.                   |
| (3) Clutch Pedal  | (7) Brake Pedal R.H.                   |
| (4) Front Bracket | <b>A: 38 to 42 mm (1.5 to 1.6 in.)</b> |

9Y1211109ENS0052US0

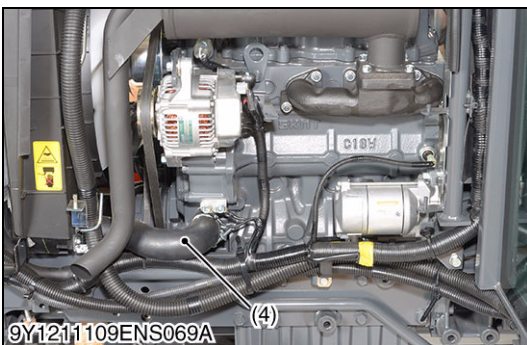
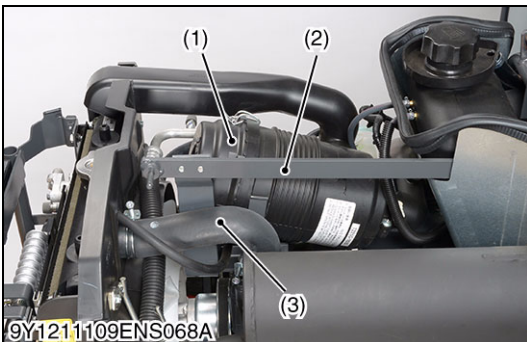

**Air Cleaner and Radiator Hoses**

1. Remove the air cleaner (1) with air cleaner hose.
2. Remove the damper stay (2)
3. Remove the radiator upper hose (3) and lower hose (4).

- |                 |                         |
|-----------------|-------------------------|
| (1) Air Cleaner | (3) Radiator Upper Hose |
| (2) Damper Stay | (4) Radiator Lower Hose |

9Y1211109ENS0053US0

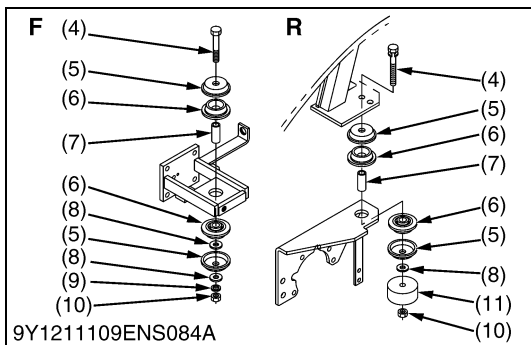
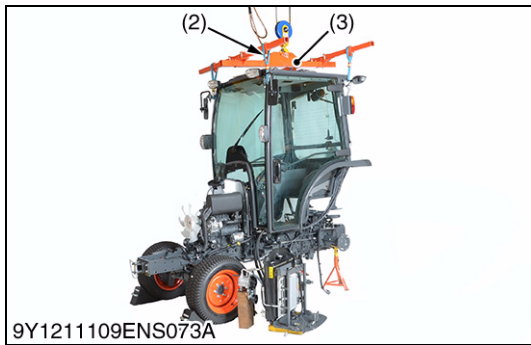
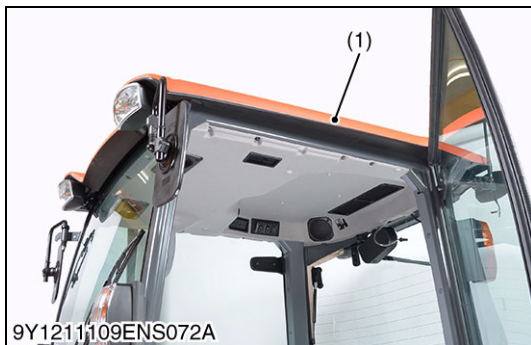
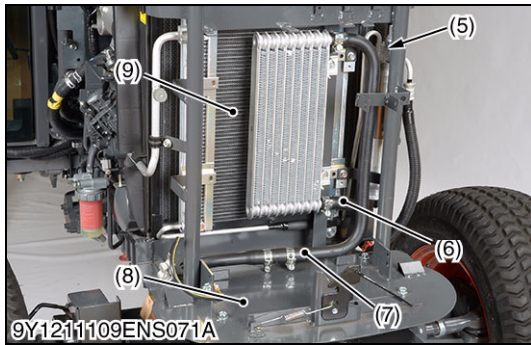
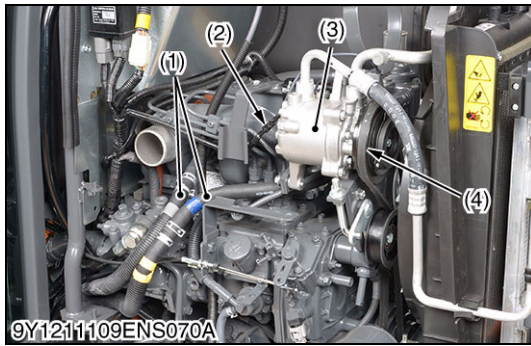

**Air Compressor and Oil Hoses**

1. Disconnect the heater hoses (1), and then reconnect their hoses to make loop.

■ **NOTE**

- **Put a mark to the each heater hose before disconnecting.**
2. Remove the air conditioner belt (4).
  3. Disconnect the compressor **1P** connector (2).
  4. Disconnect the oil cooler inlet hose (6) and outlet hose (7).
  5. Remove the battery stay mounting bolt.
  6. Remove the compressor mounting screws.
  7. Remove the compressor (3), condenser (9), receiver (5), battery stay (8) and etc. as a unit.

**(When reassembling)**

- After reassembling the compressor, be sure to adjust the air conditioner belt tension. (See page G-31.)

- |                                    |                            |
|------------------------------------|----------------------------|
| (1) Heater Hose                    | (6) Oil Cooler Inlet Hose  |
| (2) Compressor <b>1P</b> Connector | (7) Oil Cooler Outlet Hose |
| (3) Compressor                     | (8) Battery Stay           |
| (4) Air Conditioner Belt           | (9) Condenser              |
| (5) Receiver                       |                            |

9Y1211109ENS0054US0

**Cabin Assembly**

1. Remove the outer roof (1) of cabin.
2. Support the cabin with nylon straps (2), cabin dismantling tool (3) and hoists.
3. Loosen and remove the cabin mounting screw (4) and nuts (10).
4. Dismounting the cabin from tractor body.

■ **NOTE**

- **Lift the cabin while making sure it does not catch on anything.**

**(When reassembling)**

- Be sure to install the washers and mount rubbers, etc. in their original positions.

Tightening torque	Outer roof mounting screw	3.5 to 4.0 N·m 0.36 to 0.40 kgf·m 2.6 to 2.9 lbf·ft
	Cabin mounting bolt and nut	124 to 147 N·m 12.6 to 15.0 kgf·m 91.1 to 108 lbf·ft

- |                            |                   |
|----------------------------|-------------------|
| (1) Outer Roof             | (8) Plane Washer  |
| (2) Nylon Strap            | (9) Spring Washer |
| (3) Cabin Dismounting Tool | (10) Nut          |
| (4) Screw                  | (11) Collar       |
| (5) Plate                  |                   |
| (6) Mount Rubber           |                   |
| (7) Collar                 |                   |
- F: Front Side**  
**R: Rear Side**

9Y1211109ENS0055US0

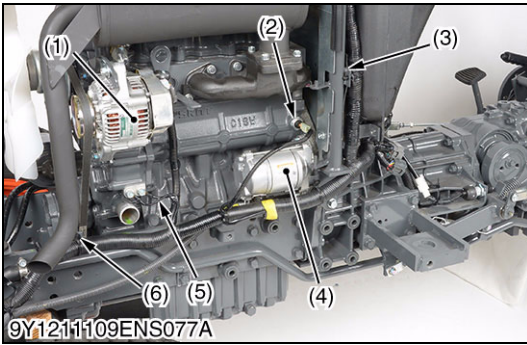
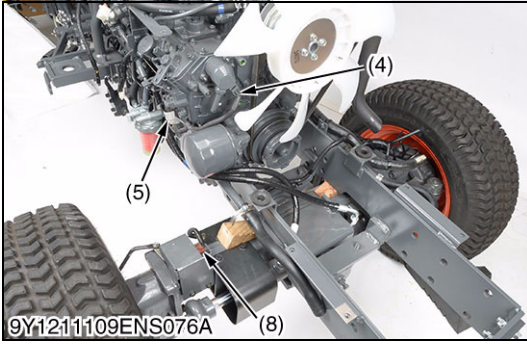
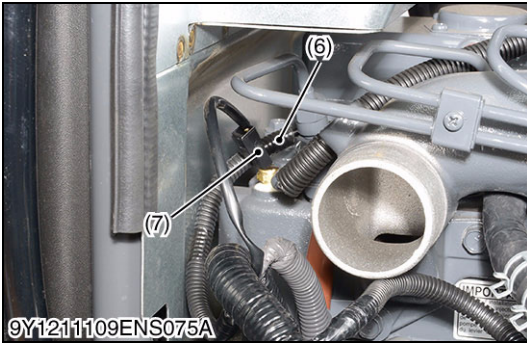
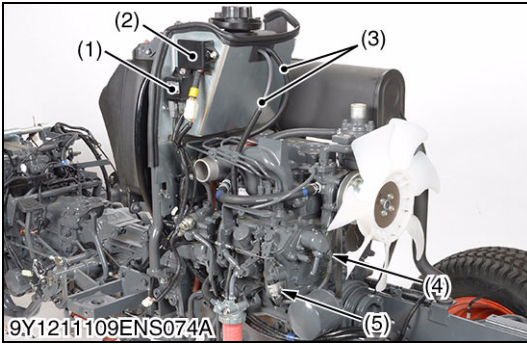

**Wiring Harness (Right Side)**

1. Disconnect the connectors for QGS controller (1) and flasher unit (2).
2. Disconnect the coolant temperature sensor connector (7) and glow plug cable (6).
3. Disconnect the connector for key stop solenoid (4), engine revolution sensor (5) and front wheel angle sensor (8).
4. Disconnect the fuel return hoses (3) from the fuel tank.

- |                       |                                |
|-----------------------|--------------------------------|
| (1) QGS Controller    | (5) Engine Revolution Sensor   |
| (2) Flasher Unit      | (6) Glow Plug Cable            |
| (3) Fuel Return Hose  | (7) Coolant Temperature Sensor |
| (4) Key Stop Solenoid | (8) Front Wheel Angle Sensor   |

9Y1211109ENS0056US0

**Wiring Harness (Left Side)**

1. Disconnect the connectors from the alternator (1), starter (4), coolant temperature sensor and oil switch (2).
2. Disconnect the grounding terminal (5).
3. Remove the clamps (3), (6).
4. Set aside the main harness to the rear.

- |                |                        |
|----------------|------------------------|
| (1) Alternator | (4) Starter            |
| (2) Oil Switch | (5) Grounding Terminal |
| (3) Clamp      | (6) Clamp              |

9Y1211109ENS0057US0

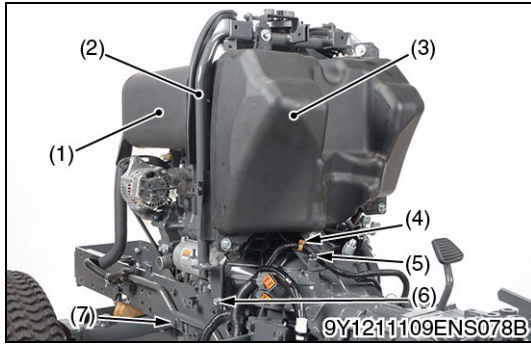

**Fuel Tank and Muffler**

1. Remove the muffler (1).
2. Pull out the clamps (4).
3. Remove the screws (5), (6) and then remove the fuel tank (3) with pillar (2).
4. Remove the retaining screw (7).

**(When reassembling)**

Tightening torque	Muffler mounting screw	32 to 37 N·m 3.2 to 3.8 kgf·m 24 to 27 lbf·ft
-------------------	------------------------	---

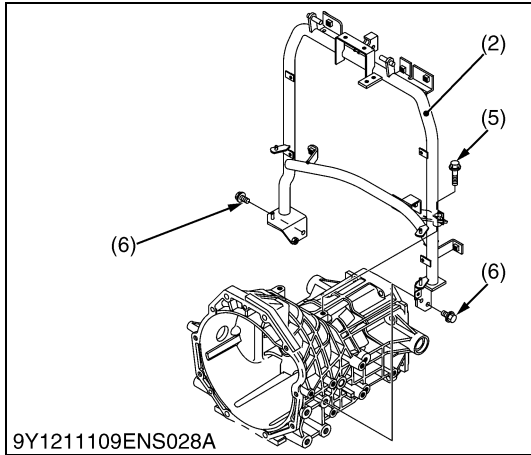

- |               |                     |
|---------------|---------------------|
| (1) Muffler   | (5) Screw           |
| (2) Pillar    | (6) Screw           |
| (3) Fuel Tank | (7) Retaining Screw |
| (4) Clamp     |                     |

9Y1211109ENS0058US0

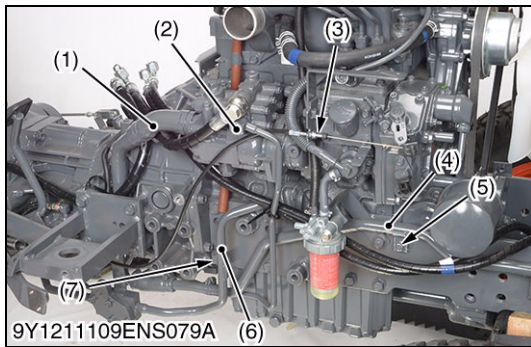

**Hydraulic Pipe and Hose**

1. Disconnect the suction hose (1) from the engine.
2. Remove the retaining screws (7) and separate the **3P** hydraulic delivery pipe (6) from the hydraulic pump.
3. Disconnect the bi-speed delivery pipe (2) from the hydraulic pump.
4. Remove the retaining screw (5), and then remove the oil cooler pipe (4).
5. Disconnect the suction hose (1).

Tightening torque	Bi-speed delivery pipe joint screw (Pump side)	34.3 to 39.2 N·m 3.5 to 4.0 kgf·m 25.3 to 28.9 lbf·ft
	Bi-speed delivery pipe retaining nut (Bi-speed valve side)	29 to 49 N·m 3.0 to 5.0 kgf·m 21.7 to 36.2 lbf·ft

- |                            |                                       |
|----------------------------|---------------------------------------|
| (1) Suction Hose           | (5) Retaining Screw                   |
| (2) Bi-speed Delivery Pipe | (6) <b>3P</b> Hydraulic Delivery Pipe |
| (3) Accelerator Wire       | (7) Retaining Screw                   |
| (4) Oil Cooler Pipe        |                                       |

9Y1211109ENS0059US0

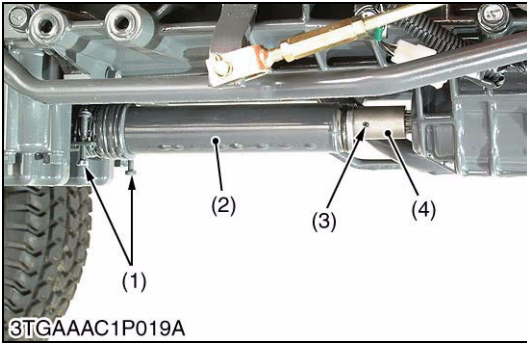

**Propeller Shaft**

1. Loosen the clamp screws (1) and slide the propeller shaft cover (2).
2. Tap out the spring pin (3) and then slide the coupling (4).
3. Remove the propeller shaft with the cover.

**(When reassembling)**

- Apply grease to the spline portion of the propeller shaft and couplings.
- When inserting the spring pins (3), face their splits in the direction parallel to the propeller shaft.
- Tighten the clamp screws (1) upward from the bottom side.

- |                           |                |
|---------------------------|----------------|
| (1) Clamp Screw           | (3) Spring Pin |
| (2) Propeller Shaft Cover | (4) Coupling   |

9Y1211109ENS0032US0

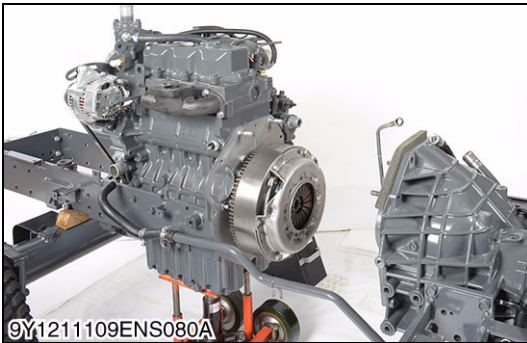

**Separating the Engine from Clutch Housing**

1. Place the disassembling stands under the clutch housing and engine oil pan.
2. Remove the starter.
3. Remove the engine mounting screws and nuts, and separate the engine from the clutch housing.

**(When reassembling)**

- Apply liquid gasket (Three Bond 1211 or equivalent) to joint face of the starter and rear end plate.
- Apply liquid gasket (Three Bond 1206C or equivalent) to joint face of the engine and clutch housing.

Tightening torque	Engine mounting screw and nut (M10)	48.1 to 55.9 N·m 4.9 to 5.7 kgf·m 35.5 to 41.2 lbf·ft
	Engine mounting nut (M12)	77.5 to 90.2 N·m 7.9 to 9.2 kgf·m 57.2 to 66.5 lbf·ft

9Y1211109ENS0060US0

### [3] DISASSEMBLING AND ASSEMBLING

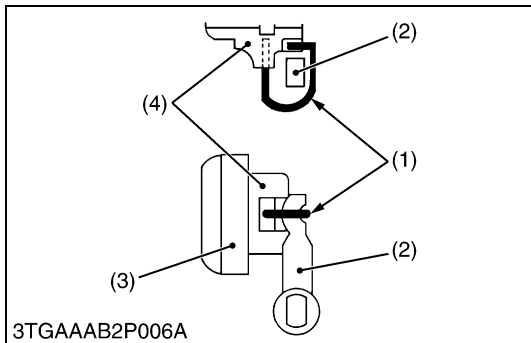
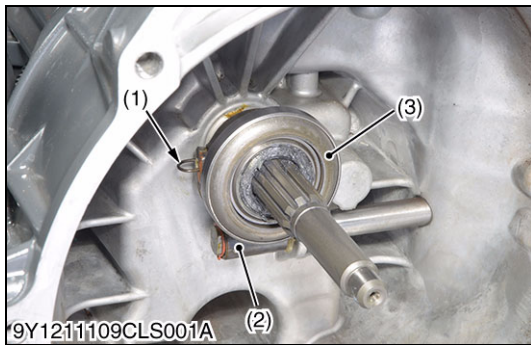
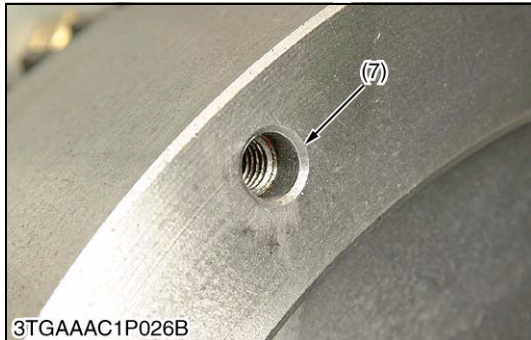
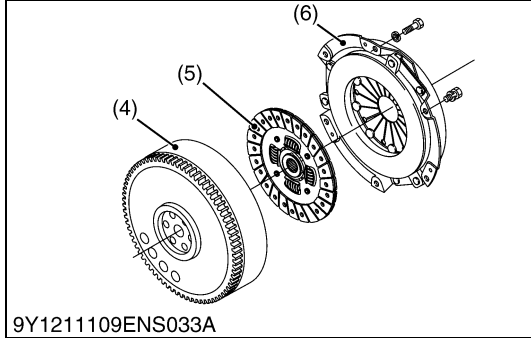
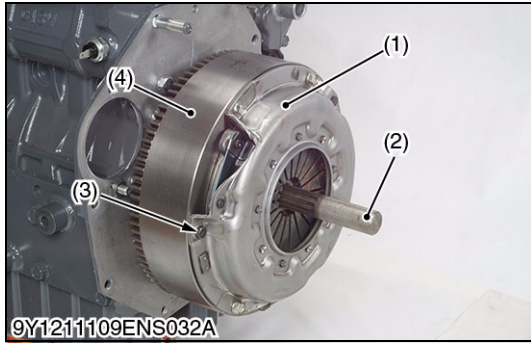

#### Clutch Assembly

1. Remove the clutch mounting screws and remove the clutch assembly (1) from the flywheel (4).

#### (When reassembling)

- Direct the shorter end of the clutch disc boss toward the flywheel (4).
- Apply molybdenum disulphide (Three Bond 1901 or equivalent) to the splines of clutch disc boss.
- Screws in two reamer screws (3) in the reamer screw holes (7).
- After tightening the reamer screws (3), tighten the other general screws.

#### ■ IMPORTANT

- Align the center of clutch disc (5) and flywheel (4) by inserting the clutch center tool (2).

#### ■ NOTE

- Do not allow grease and oil on the clutch disc facing.
- The reamer screw hole (7) on the clutch cover is in the next of the 5 mm (0.2 in.) dia. hole.
- The shape of the reamer screw hole (7) on the flywheel (4) is different from other screw holes.

Tightening torque	Clutch mounting screw	23.5 to 27.5 N·m 2.4 to 2.8 kgf·m 17.4 to 20.2 lbf·ft
-------------------	-----------------------	---

- |                        |                                 |
|------------------------|---------------------------------|
| (1) Clutch Assembly    | (5) Clutch Disc                 |
| (2) Clutch Center Tool | (6) Clutch Cover                |
| (3) Reamer Screw       | (7) Screw Hole for Reamer Screw |
| (4) Flywheel           |                                 |

9Y1211109ENS0034US0

#### Clutch Release Fork

1. Remove the set spring (1) from clutch release fork (2) and release hub.
2. Remove the release bearing (3) with release hub (4).

#### (When reassembling)

- Set the clutch release fork (2) and release hub (4) with set spring (1) in the correct direction.

- |                         |                     |
|-------------------------|---------------------|
| (1) Set Spring          | (3) Release Bearing |
| (2) Clutch Release Fork | (4) Release Hub     |

9Y1211109CLS0006US0

## [4] SERVICING

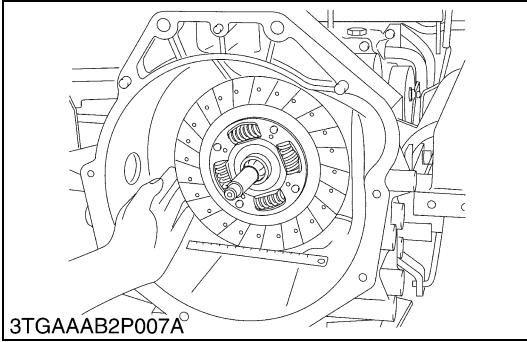

### **Backlash between Clutch Disc and Clutch Shaft**

1. Mount the clutch disc onto the propeller shaft.
2. Hold the propeller shaft so that it does not rotate.
3. Slightly move the disc and measure the displacement around disc edge.
4. If the measurement exceeds the allowable limit, replace clutch disc.

Displacement around disc edge	Allowable limit	2.0 mm 0.079 in.
-------------------------------	-----------------	---------------------

9Y1211109CLS0007US0

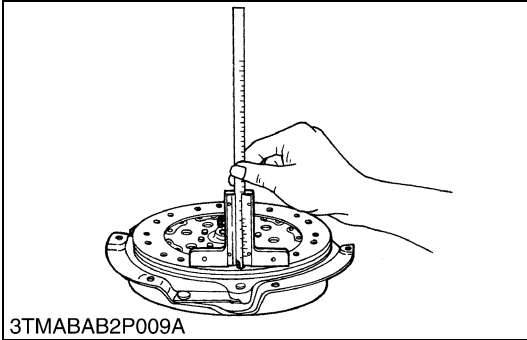

### **Clutch Disc Wear**

1. Measure the depth from clutch disc surface to the top of rivet at least 10 points with a depth gauge.
2. If the depth is less than the allowable limit, replace the disc.
3. If oil is sticking to clutch disc, or disc surface is carbonized, replace the clutch disc.

Disc surface to rivet top (Depth)	Allowable limit	0.3 mm 0.012 in.
-----------------------------------	-----------------	---------------------

9Y1211109CLS0008US0

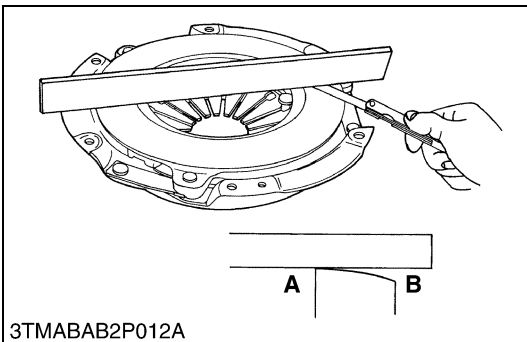

### **Pressure Plate Flatness**

1. Place a straightedge on the pressure plate and measure clearance with a feeler gauge at several points.
2. If the clearance exceeds the allowable limit, replace it.
3. When the pressure plate is worn around its outside and its inside surface only is in contact with the straightedge, replace even if the clearance is within allowable limit.

Clearance between pressure plate and straightedge	Allowable limit	0.2 mm 0.008 in.
---	-----------------	---------------------

A: Inside

B: Outside

9Y1211109CLS0009US0

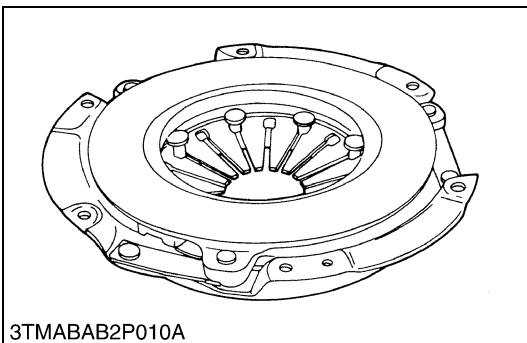

### **Checking Pressure Plate Assembly and Flywheel**

1. Wash the disassembling parts except clutch disc with a suitable cleaning solvent to remove dirt and grease before making inspection and adjustment.
2. Inspect the friction surface of pressure plate and flywheel for scoring or roughness.
  - Slight roughness may be smoothed by using fine emery cloth.
  - If these parts have deep scores or grooves on their surface, they should be replaced.
3. Inspect the surface of diaphragm spring for wear. If excessive wear is found, replace the clutch cover assembly.
4. Inspect thrust rings (wire ring) for wear or damage. As these parts are invisible from outside, shake pressure plate assembly up and down to listen for chattering noise, or lightly hammer on rivets for a slightly cracked noise. Any of these noises indicates need of replace as a complete assembly.

Diaphragm spring mutual difference	Allowable limit	0.5 mm 0.020 in.
------------------------------------	-----------------	---------------------

9Y1211109CLS0010US0

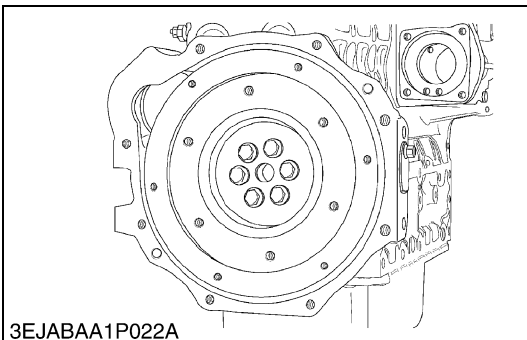



**Checking Clutch Release Bearing**

1. Check the clutch release bearing. If surface is worn excessively, or abnormal sounds occur, replace it.

9Y1211109CLS0011US0

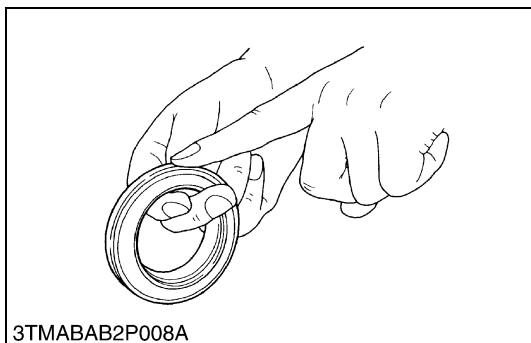

# **3 TRANSMISSION**

# MECHANISM

## CONTENTS

1. STRUCTURE.....	3-M1
2. POWER TRAIN FOR TRAVELING SYSTEM.....	3-M2
[1] HYDROSTATIC TRANSMISSION (HST).....	3-M2
(1) Structure.....	3-M2
(2) Hydraulic Circuit.....	3-M3
(3) Pump and Motor.....	3-M4
(4) Operation and Valves.....	3-M5
(5) Control Linkage.....	3-M9
(6) Cruise Control Linkage.....	3-M10
(7) Cruise Control Release System.....	3-M11
[2] RANGE GEAR SHIFT SECTION.....	3-M12
[3] FRONT WHEEL DRIVE SECTION.....	3-M12
[4] BI-SPEED TURN SYSTEM.....	3-M13
(1) Feature.....	3-M13
(2) Related Parts and Arrangement.....	3-M13
(3) Hydraulic Oil Flow.....	3-M14
(4) Power Train of Hydraulic Clutch Section.....	3-M15
3. POWER TRAIN FOR PTO SYSTEM.....	3-M16
[1] INDEPENDENT PTO SYSTEM.....	3-M16
(1) Hydraulic Oil Flow.....	3-M16
(2) Power Train of PTO Clutch Section.....	3-M17
[2] REAR PTO GEAR SHIFT SECTION.....	3-M18
[3] MID PTO GEAR SHIFT SECTION.....	3-M18

# 1. STRUCTURE

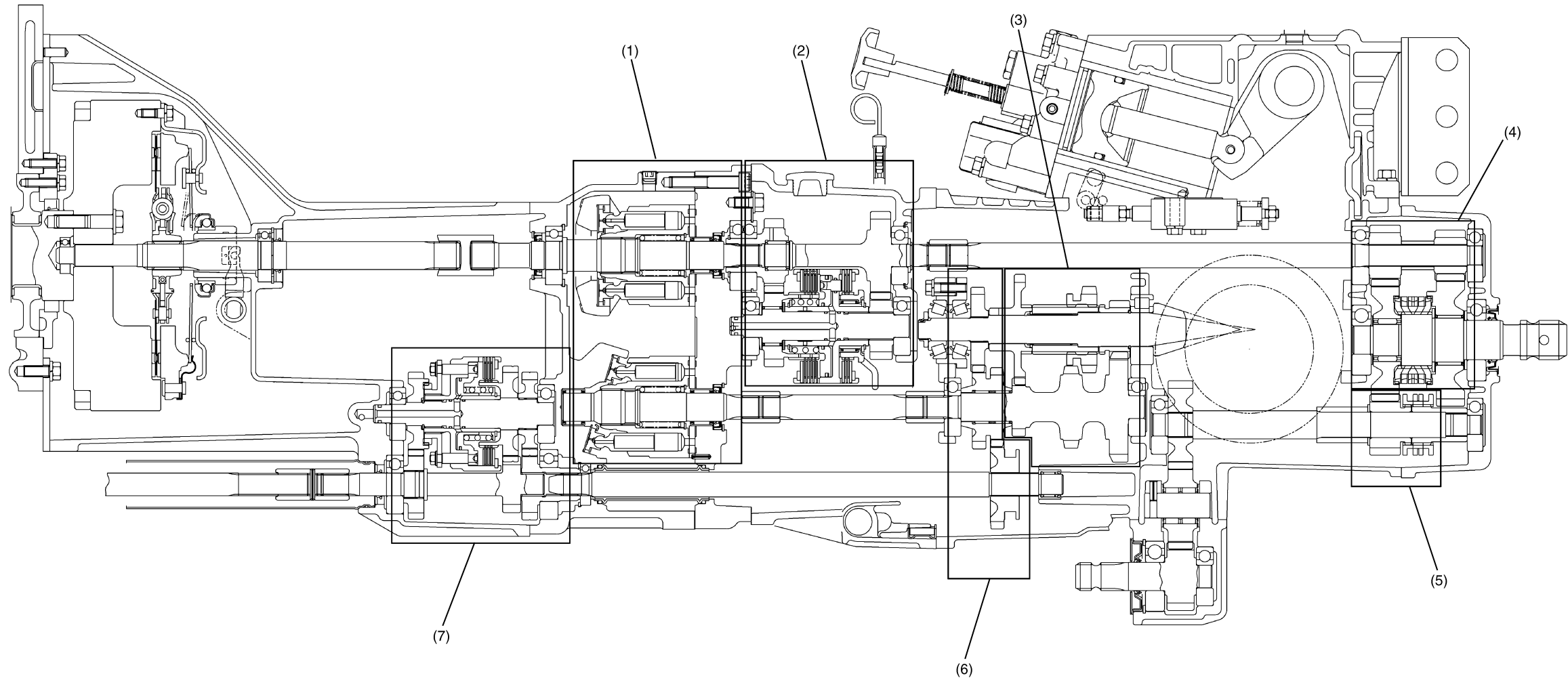

9Y1211109TRT001A

(1) HST (Hydrostatic Transmission) Section  
(2) PTO Clutch Section

(3) Range Gear Shift Section

(4) Rear PTO Gear Shift Section

(5) Mid PTO Gear Shift Section

(6) Front Wheel Drive Section

(7) Bi-speed Turn Clutch Section

## 2. POWER TRAIN FOR TRAVELING SYSTEM

### [1] HYDROSTATIC TRANSMISSION (HST)

#### (1) Structure

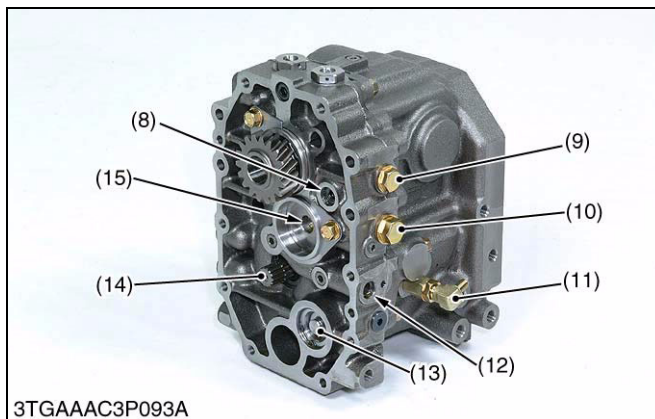
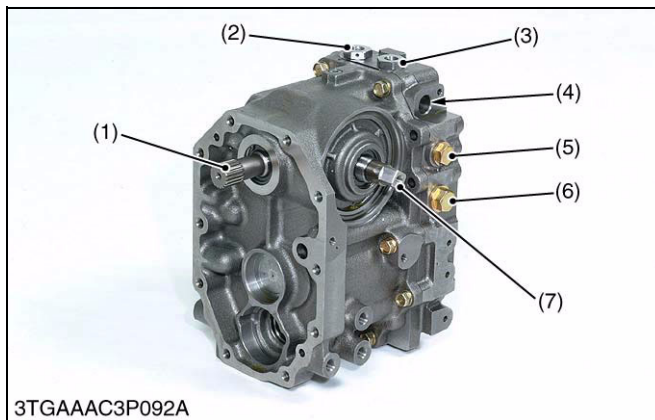

Hydrostatic transmission consists of variable displacement piston pump, fixed displacement piston motor, charge pump and valve system.

- |   |  |
|---|--|
| (1) Input Shaft                                     | (11) Hose Joint (for PTO Clutch)       |
| (2) Neutral Valve (Reverse)                         | (12) Charge Oil Inlet                  |
| (3) Neutral Valve (Forward)                         | (13) Accumulator (for PTO Clutch)      |
| (4) Drain Port                                      | (14) Output Shaft                      |
| (5) Pressure Check Port Plug (Forward)              | (15) Oil Exit (for PTO Clutch)         |
| (6) Check and High Pressure Relief Valve (Forward)  | (16) Case                              |
| (7) Trunnion Shaft                                  | (17) Variable Displacement Piston Pump |
| (8) Case Relief Valve                               | (18) Fixed Displacement Piston Motor   |
| (9) Pressure Check Port Plug (Reverse)              | (19) Port Block                        |
| (10) Check and High Pressure Relief Valve (Reverse) | (20) Charge Relief Valve               |

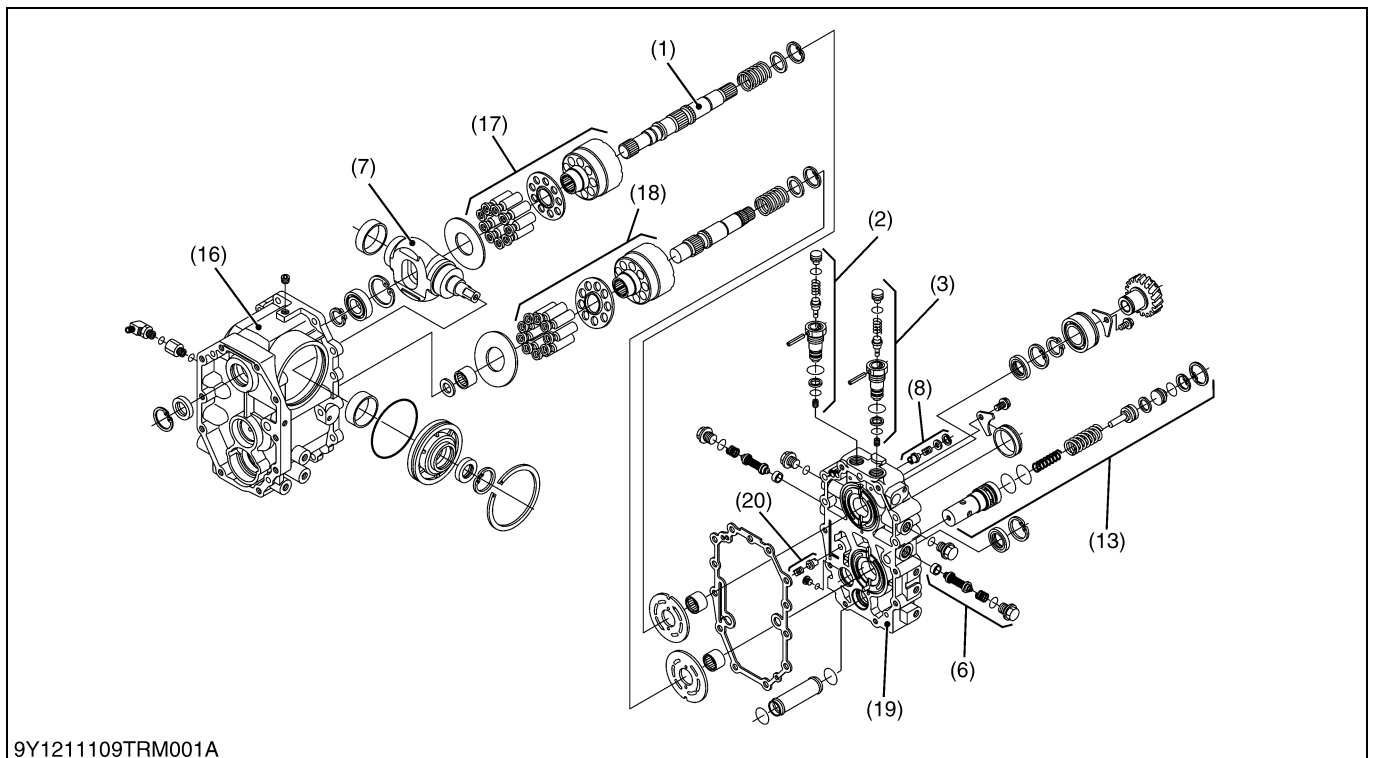

9Y1211109TRM0002US0

**(2) Hydraulic Circuit**

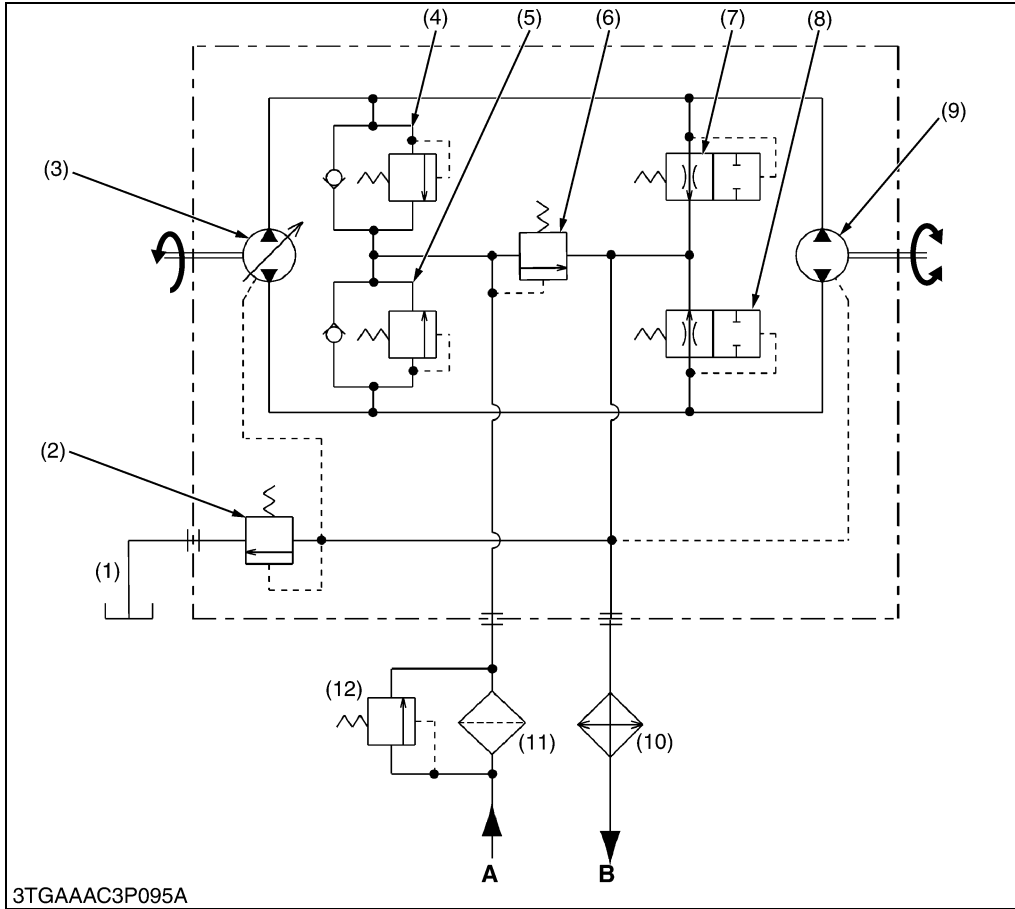

- (1) Oil Tank (Transmission Case)
  - (2) Case Relief Valve
  - (3) Variable Displacement Pump (HST Pump)
  - (4) Check and High Pressure Relief Valve (Forward)
  - (5) Check and High Pressure Relief Valve (Reverse)
  - (6) Charge Relief Valve
  - (7) Neutral Valve (Forward)
  - (8) Neutral Valve (Reverse)
  - (9) Fixed Displacement Motor (HST Motor)
  - (10) Oil Cooler
  - (11) Oil Filter
  - (12) Bypass Valve
- A: From Power Steering Controller**  
**B: To Hydraulic Pump**

3TGAAAC3P095A

The HST pump is driven by the engine output power through the clutch and the drive shaft. The oil flow volume and its direction is controlled by operating the speed change pedal or the cruise control lever, then the output speed and direction of the HST motor is controlled.

The HST is structured the variable displacement pump, fixed displacement motor, oil filter, charge relief valve, neutral valve, case relief valve etc.. The oil cooler is equipped on the drain circuit.

**Valve Operating Pressure**

Ref. No.	Valve	Oil Temperature	Engine Revolution	Valve Operating Pressure	
(2)	Case Relief Valve	40 to 60 °C 104 to 140 °F	1500 min <sup>-1</sup> (rpm)	Less than 0.3 MPa (3 kgf/cm <sup>2</sup> , 40 psi) at no-load	
(4), (5)	Check and High Pressure Relief Valve (Forward and Reverse)			26.4 to 29.4 MPa (270 to 299 kgf/cm <sup>2</sup> , 3830 to 4260 psi)	
(6)	Charge Relief Valve			0.4 to 0.8 MPa (4 to 8 kgf/cm <sup>2</sup> , 60 to 100 psi) at no-load	
(7), (8)	Neutral Valve (Forward and Reverse)			Open	1.47 to 2.45 MPa (15.0 to 24.9 kgf/cm <sup>2</sup> , 214 to 355 psi)
		Close	4.9 to 9.8 MPa (50 to 99 kgf/cm <sup>2</sup> , 710 to 1400 psi)		

9Y1211109TRM0003US0

### (3) Pump and Motor

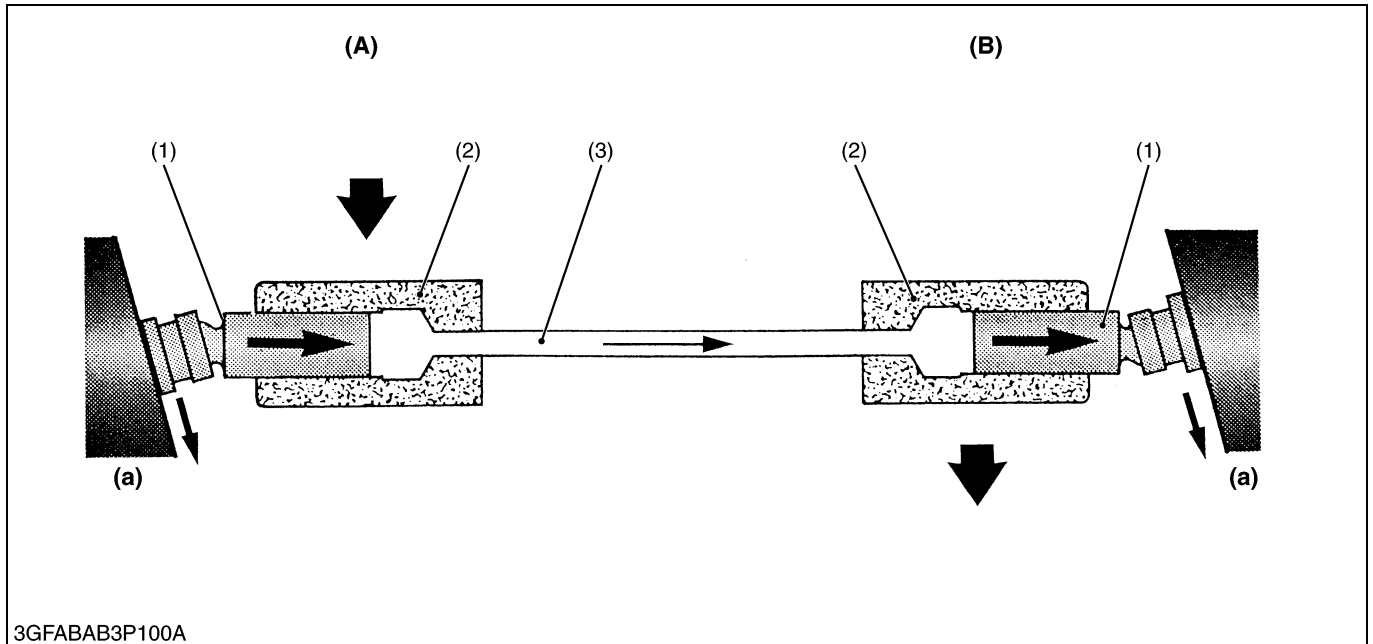

(1) Piston

(2) Cylinder

(3) Oil

(A) Pump

(B) Motor

(a) Swashplate

Pump and motor cylinder, each containing pistons, are connected by lines. Cylinders and lines are filled with oil. Pistons ride against swashplates located in pump and motor.

In the pump, as the cylinder rotates, pistons move across the sloping face of swashplate and slide in or out of their cylinder bores. The oil, forced out by the pump pistons, causes the motor pistons to slide out of their cylinder bores.

In the motor, sliding out of the cylinder and moving across the sloping face of swashplate, the pistons rotate the cylinder.

9Y1211109TRM0004US0

### (4) Operation and Valves

#### Neutral Position

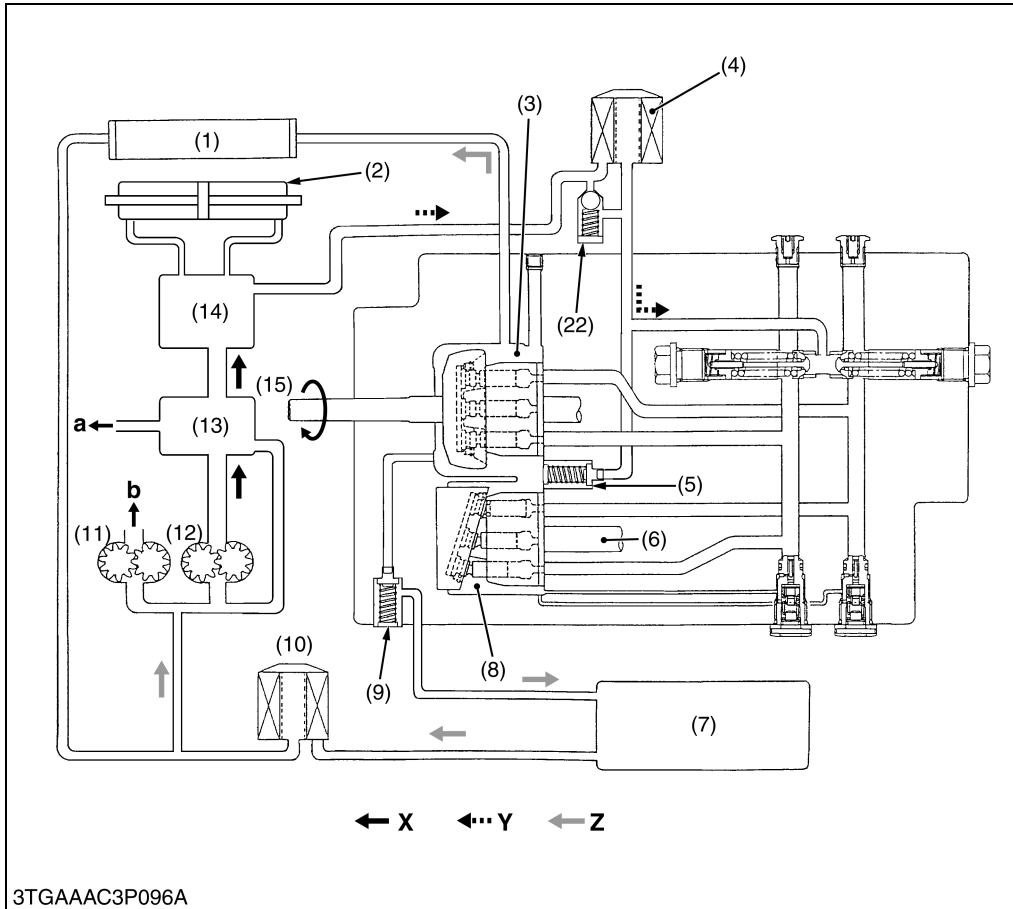

- (1) Oil Cooler
  - (2) Power Steering Cylinder
  - (3) HST Pump (Variable Discharge Pump)
  - (4) HST Oil Filter (10 μ)
  - (5) Charge Relief Valve
  - (6) Output Shaft
  - (7) Oil Tank (Transmission Case)
  - (8) HST Motor (Fixed Discharge Motor)
  - (9) Case Relief Valve
  - (10) Oil Filter
  - (11) 3P Hydraulic Pump
  - (12) Power Steering Pump
  - (13) Regulating Valve
  - (14) Steering Controller
  - (15) Input Shaft
  - (16) Variable Swashplate
  - (17) Piston (Pump)
  - (18) Cylinder Block (Pump)
  - (19) Cylinder Block (Motor)
  - (20) Piston (Motor)
  - (21) Fixed Swashplate
  - (22) Bypass Valve
- a: To Bi-speed Valve**  
**b: To 3-Point Linkage**  
**X: High Pressure Oil**  
**Y: Low Pressure Oil**  
**Z: Suction or Drain Oil**

3TGAAAC3P096A

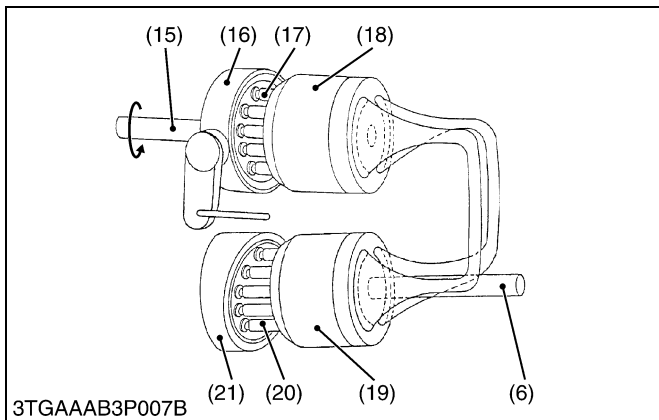

3TGAAAB3P007B

The pump (3) and motor (8) are joined in a closed hydraulic loop and most of oil circulates within the main oil circuit. A little oil lubricates and oozes out from the clearance between the moving parts of the case.

The charge oil aids smooth operation of piston pump (3) and motor (8). The rest of the oil passes through the charge relief valve (5) into the case. Then the oil return to the pump (12) through the cooler.

When the speed control pedal is in neutral, the variable swashplate (16) is at right angles to the pump pistons (17) and they only rotate with cylinder block (18) without reciprocating. Since the oil is not being pumped to the motor (8). The cylinder block (19) in the motor (8) is stationary and the output shaft (6) does not move.

9Y1211109TRM0005US0