

(2) Hydraulic Pump (3-Point Hydraulic System)

Flowmeter Connecting and Test Preparation

■ IMPORTANT

- When using a flowmeter other than KUBOTA specified flowmeter (Code No.: 07916-52792), be sure to use the instructions with that flowmeter.
- The flowmeter does not provide relief valve. Therefore while testing, do not close the flowmeter loading valve completely.

1. Remove the 3P delivery pipe (2) from hydraulic pump (1).
2. Set the adaptor flowmeter (4) (see page G-48) and adaptor 53 to the hydraulic pump (1).
3. Connect the hydraulic test hose (7) (Code No.: 07916-52651) to the adaptor 53 and flowmeter (Code No.: 07916-52791) inlet port.
4. Connect the another hydraulic test hose (6) to flowmeter outlet port and insert to the transmission fluid inlet (3).
5. Open the flowmeter loading valve completely. (Turn counterclockwise.)
6. Start the engine and set the engine speed 2700 min⁻¹ (rpm).
7. Slowly close the loading valve to generate the pressure approx. 15.7 MPa (160 kgf/cm², 2276 psi).
8. Hold in this condition until oil temperature reaches approx. 40 °C (104 °F).

(Reference)

- Adaptor is included in the adaptor set (Code No.: 07916-54031).

- | | |
|------------------------------|-------------------------|
| (1) Hydraulic Pump | (5) Adaptor 53 |
| (2) 3P Delivery Pipe | (6) Hydraulic Test Hose |
| (3) Transmission Fluid Inlet | (7) Hydraulic Test Hose |
| (4) Adaptor Flowmeter | |

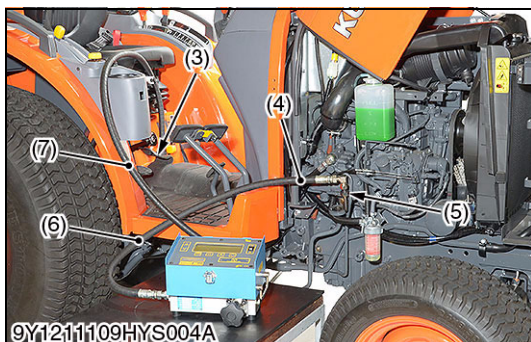
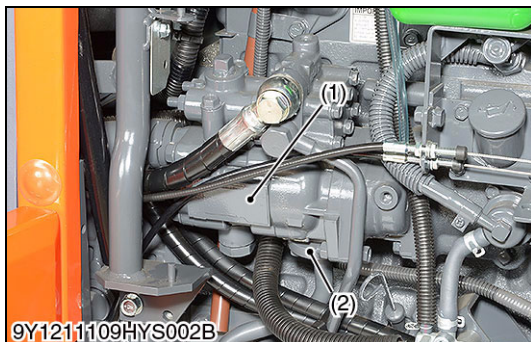

9Y1211109HYS0006US0



9Y1211109HYS004B

Pump Test

NOTE

• Before pump testing, perform the flowmeter connecting and test preparation.

1. Open the loading valve completely.
2. Start the engine and set at approx. 2700 min⁻¹ (rpm).
3. Read and note the pump delivery at no pressure.
4. Slowly close the loading valve to increase pressure approx. 16.67 MPa (170 kgf/cm², 2417.9 psi).
5. Read and note the pump flow at rated pressure.
6. Open the loading valve and stop the engine.

(Reference)

Hydraulic pump delivery at no pressure	Factory specification	30.6 L/min. 8.08 U.S.gals/min. 6.73 Imp.gals/min.
Hydraulic pump delivery at rated pressure	Factory specification	30.0 L/min. 7.93 U.S.gals/min. 6.60 Imp.gals/min.
	Allowable limit	25.2 L/min. 6.66 U.S.gals/min. 5.54 Imp.gals/min.

Condition

- Engine speed:
Approx. 2700 min⁻¹ (rpm)
- Rated pressure:
16.67 MPa (170 kgf/cm², 2417.9 psi)
- Oil temperature:
40 to 60 °C (104 to 140 °F)

9Y1211109HYS0007US0

(3) Regulator Valve

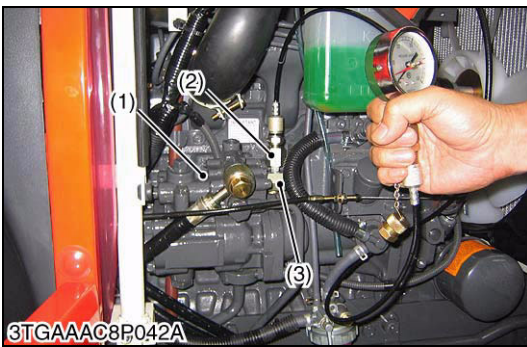

3TGAAAC8P042A

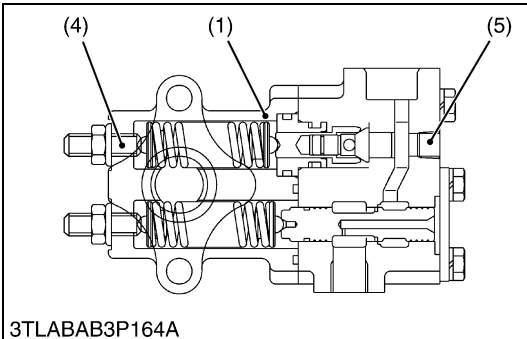

3TLABAB3P164A

Checking Regulating Valve Setting Pressure

1. Start the engine and warm up the transmission fluid, and then stop the engine.
2. Remove the pressure checking port (5) plug (PT 1/8).
3. Install the adaptor 7 to checking port (PT 1/8) (5), and then install the adaptor D, the threaded joint, cable and pressure gauge.
4. Start the engine and set the maximum engine speed.
5. Measure the pressure. (Do not turn the steering wheel.)
6. If the measurement is not within factory specifications, adjust the regulating valve adjustor (4) on the regulator valve (1).

Regulating valve setting pressure	Factory specification	10.7 to 11.7 MPa 110 to 119 kgf/cm ² 1560 to 1690 psi
-----------------------------------	-----------------------	--

Condition

- Engine speed:
Maximum
- Oil temperature:
40 to 60 °C (104 to 140 °F)

(Reference)

- Turn to clockwise direction → Pressure is increased
- Turn to counterclockwise direction → Pressure is decreased

- | | |
|---------------------|-------------------------------|
| (1) Regulator Valve | (4) Regulating Valve Adjustor |
| (2) Adapter D | (5) Checking Port (PT 1/8) |
| (3) Adapter 7 | |

9Y1211109HYS0008US0

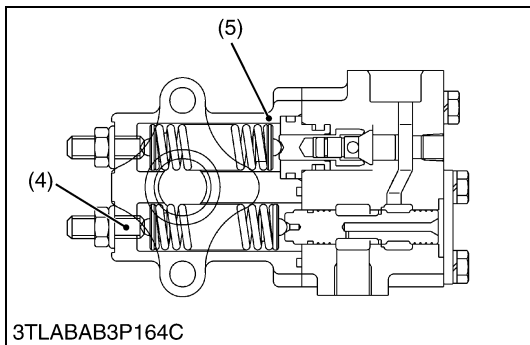
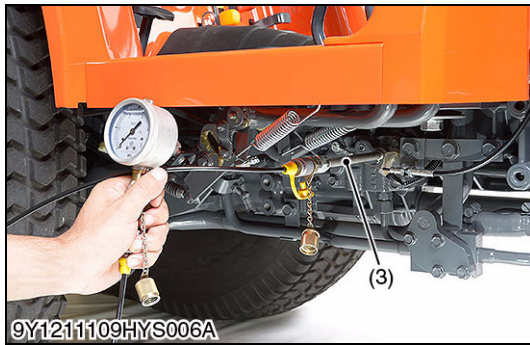
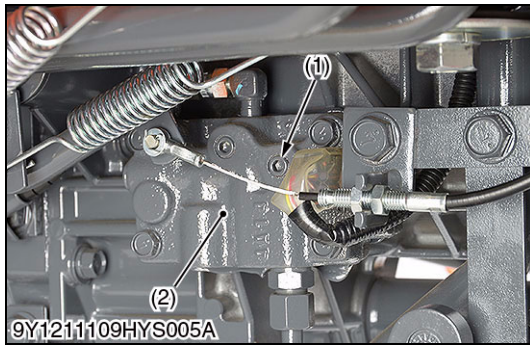

(4) Regulator Valve

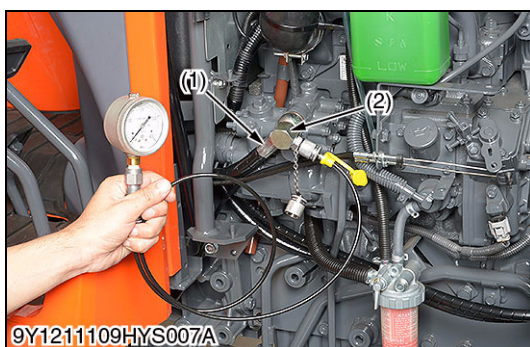

Checking Bi-speed / PTO System Pressure

1. Start the engine and warm up the transmission fluid, and then stop the engine.
2. Remove the bi-speed system pressure checking port (PT 1/8) (1) plug (PT 1/8) on the bi-speed valve (2).
3. Install the long connector (code: 07916-60831) to checking port (1), and then install the threaded joint, cable and pressure gauge.
4. Start the engine and set the idling speed.
5. Measure the pressure.
6. If the measurement is not within factory specifications, adjust the pressure reducing valve adjustor (4) on the regulator valve (5).

Bi-speed / PTO system pressure	Factory specification	1.76 to 1.86 MPa 18 to 19 kgf/cm ² 256 to 270 psi
--------------------------------	-----------------------	--

Condition

- Engine speed:
Idling speed
- Oil temperature:
40 to 60 °C (104 to 140 °F)

(Reference)

- Turn to clockwise direction → Pressure is increased
- Turn to counterclockwise direction → Pressure is decreased

- | | |
|--|--|
| (1) System Pressure Checking Port (PT 1/8) | (3) Long Connector
(Code: 07916-60831) |
| (2) Bi-speed Valve | (4) Pressure Reducing Valve Adjustor |
| | (5) Regulator Valve |

9Y1211109HYS0009US0

Relief Valve Setting Pressure

1. Remove the power steering delivery pipe from hydraulic pump.
2. Assemble the power steering delivery pipe (1) using a adaptor **E** (2) instead of original joint.
3. Start the engine. After warming up, set the engine speed at maximum.
4. Fully turn the steering wheel to the left end to read the relief pressure. After reading, stop the engine.
5. If the pressure is not within the factory specification, check the pump delivery line and replace the steering controller assembly.

Power steering relief valve setting pressure	Factory specification	12.5 to 13.5 MPa 128 to 137 kgf/cm ² 1820 to 1950 psi
--	-----------------------	--

Condition

- Engine speed:
Maximum
- Oil temperature:
40 to 60 °C (104 to 140 °F)

- | | |
|----------------------------------|----------------------|
| (1) Power Steering Delivery Pipe | (2) Adaptor E |
|----------------------------------|----------------------|

9Y1211109HYS0010US0

(5) 3-Point Hydraulic System

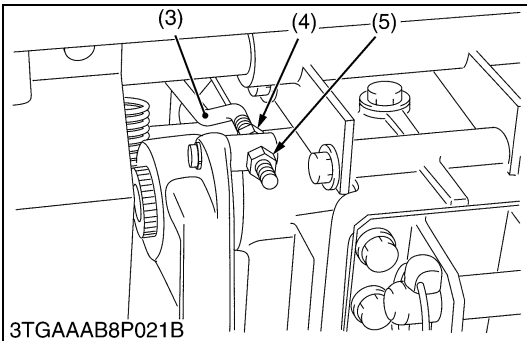
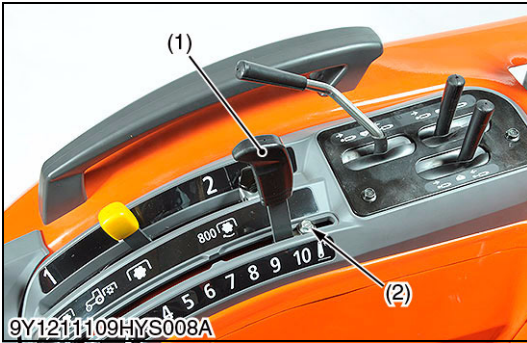

Adjusting Feedback Rod

1. Set the position control lever (1) to the floating position.
2. Start the engine, and after warming-up, set the engine speed at 1000 to 1500 min⁻¹ (rpm).
3. Set the position control lever stopper (2) to the maximum raising position.
4. Move the position control lever (1) to the maximum raising position. (See photo).
5. Turn the adjusting nut (5) and lock nut (4) until the relief valve begins to be operated. (Turn to clockwise).
6. Then turn back the adjusting nut (5) counterclockwise by 2 turn.
7. Tighten the lock nut (4) and set the engine speed to maximum.
8. Move the position control lever to the lowest position and maximum raising position (3 to 5 times to check the relief valve does not operate).
9. Set the position control lever to the maximum raising position, then move the lift arm to the upper end by hand and measure the free travel.
10. Stop the engine.
11. If the measurement is not within the factory specification, adjusting position control rod again.

Lift arm free travel at maximum raising position	Factory specification	12 to 17 mm 0.48 to 0.66 in.
--	-----------------------	---------------------------------

Condition

- Engine speed: Maximum
- Oil temperature: 40 to 60 °C (104 to 140 °F)

- | | |
|--|-------------------|
| (1) Position Control Lever | (3) Feedback Rod |
| (2) Position Control Lever Stopper (at Maximum Raising Position) | (4) Lock Nut |
| | (5) Adjusting Nut |

9Y1211109HYS0011US0

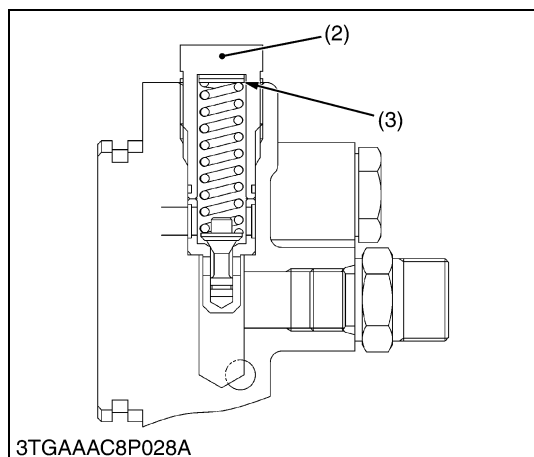

Relief Valve Setting Pressure Test Using Pressure Tester

1. Start the engine and move the position control lever to the maximum raising position.
2. Turn the feedback rod adjusting nut and lock nut until the relief valve begins to be operated. (Refer to 8-S11 "Adjusting Feedback Rod".).
3. Move the position control lever to the lowest position and stop the engine.
4. Remove the plug of hydraulic cylinder cover and install the adaptor 4. Then connect the cable (Code No.: 07916-50331) and pressure gauge (Code No.: 07916-50322) to adaptor 4.
5. Start the engine and set the engine speed at maximum.
6. Move the position control lever to the maximum raising position and read the pressure when the relief valve functions.
7. Stop the engine.
8. If the pressure is not within the factory specification, remove the relief valve plug (2) and adjust with adjusting shims (3).
9. After the relief valve setting pressure test, adjust the feedback control rod. (See page 8-S11.)

Relief valve setting pressure	Factory specification	16.7 to 17.2 MPa 170 to 175 kgf/cm ² 2420 to 2480 psi
-------------------------------	-----------------------	--

Condition

- Engine speed:
Maximum
- Oil temperature:
40 to 60 °C (104 to 140 °F)

(Reference)

- Adaptor 4 is included in engine oil pressure tester (Code No.: 07916-32032).
- Thickness of shim (3):
0.1 mm (0.0039 in.)
0.2 mm (0.0078 in.)
0.4 mm (0.0157 in.)
- Pressure change per 0.1 mm (0.0039 in.) shim:
Approx. 264.8 kPa (2.7 kgf/cm², 38.4 psi)

- (1) Adaptor 4
(2) Relief Valve Plug

- (3) Shim

9Y1211109HYS0012US0

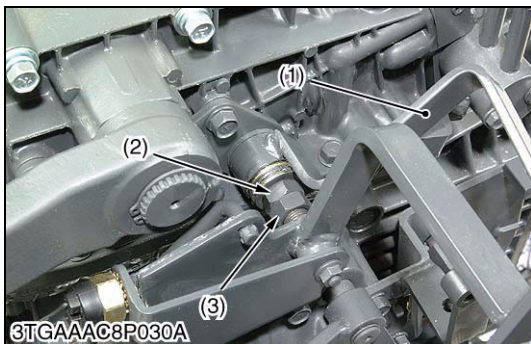

Adjusting Position Control Lever Operating Force

1. Set a spring balance to the position control lever (1) to measure the operating force.
2. If the measurement is not within the factory specification, loosen the lock nut (3) and adjust the operating force with position control lever mounting nut (2).

(When reassembling)

- Be sure to tight the lock nut.

Position control lever operating force	Factory specification	20 to 50 N 2.1 to 5.0 kgf 4.5 to 11 lbf
--	-----------------------	---

- (1) Position Control Lever
(2) Mounting Nut

- (3) Lock Nut

9Y1211109HYS0013US0

[2] DISASSEMBLING AND ASSEMBLING

(1) Hydraulic Pump (Power Steering and 3-Point Hydraulic System)

■ IMPORTANT

- The hydraulic pump is precision machined and assembled: if disassembled once, it may be unable to keep its original performance. Therefore, when the hydraulic pump fails, replacement should be carried out with the hydraulic pump assembled except when emergency repair is unavoidable.
- When repair is required, follow the disassembly and servicing procedures shown below with utmost care.
- Be sure to test the hydraulic pump with a flowmeter before disassembling.
- After reassembly, be sure to perform break-in operation and ensure that there is nothing abnormal with the hydraulic pump.

9Y1211109HYS0014US0

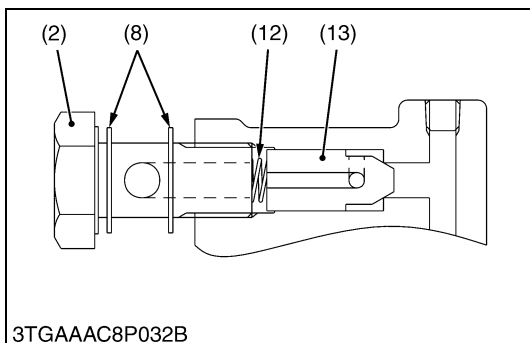
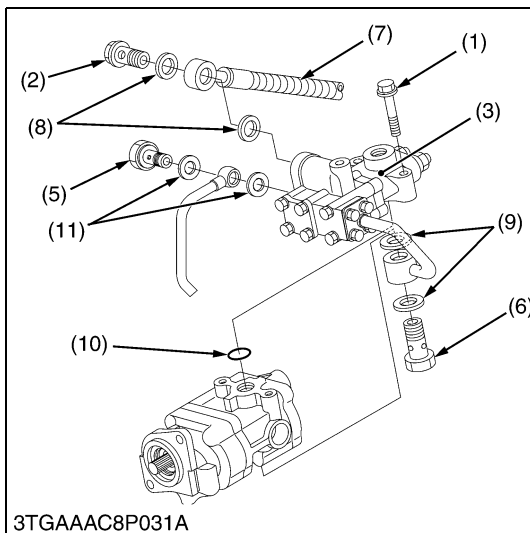
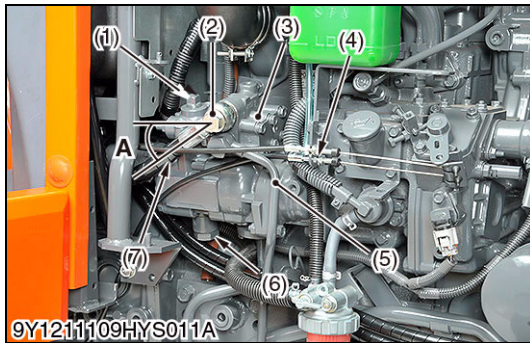

Removing Hydraulic Pump Assembly

1. Open the hood and remove the side cover (R.H.).
2. Disconnect the accelerator wires (4) from the engine.
3. Remove the joint screw (2) and disconnect the power steering delivery hose (7).
4. Remove the joint screw (5) and disconnect the bi-speed delivery pipe.
5. Remove the joint screw (6) and mounting screws (1), and separate the regulating valve (3) from the hydraulic pump.

(When reassembling)

- Apply grease to the O-ring (10) on the regulator valve (3) and be careful not to damage it.
- Be sure to install the poppet (13), spring (12) and copper gasket (8), (9), (11).

Tightening torque	Joint screw (2) (Power steering delivery hose)	49 to 58.8 N·m 5.0 to 6.0 kgf·m 36.2 to 43.4 lbf·ft
	Joint screw (5) (Bi-speed delivery pipe)	34.3 to 39.2 N·m 3.5 to 4.0 kgf·m 25.3 to 28.9 lbf·ft
	Joint screw (6) (Regulator delivery pipe)	39.2 to 49.0 N·m 4.0 to 5.0 kgf·m 28.9 to 36.2 lbf·ft
	Regulator valve mounting screw	17.7 to 20.6 N·m 1.8 to 2.1 kgf·m 13.0 to 15.2 lbf·ft

Delivery hose (7) installation angle "A"	Factory specification	0.52 rad 30 °
---	-----------------------	------------------

- | | |
|--|--------------------|
| (1) Mounting Screw | (8) Copper Gasket |
| (2) Joint Screw (Power Steering Delivery Hose) | (9) Copper Gasket |
| (3) Regulator Valve | (10) O-ring |
| (4) Accelerator Wire | (11) Copper Gasket |
| (5) Joint Screw (Bi-speed Delivery Pipe) | (12) Spring |
| (6) Joint Screw (Regulator Delivery Pipe) | (13) Poppet |
| (7) Power Steering Delivery Hose | |

A: Installation Angle of Power Steering Delivery Hose

(To be continued)

(Continued)

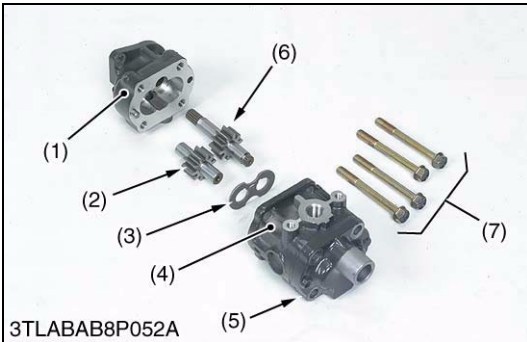
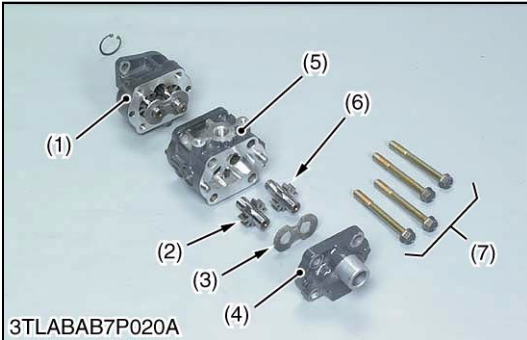
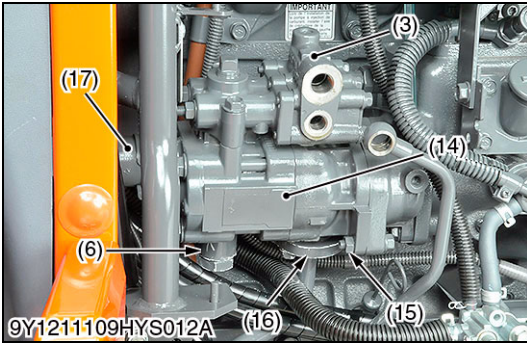

6. Loosen the clump and separate the suction hose (17) from the hydraulic pump (8).
7. Disconnect the 3P delivery pipe (16) from the hydraulic pump (14).
8. Remove the mounting screws (15) and remove the hydraulic pump (14).

- (14) Hydraulic Pump
- (15) Mounting Screw
- (16) 3P Delivery Pipe
- (17) Suction Hose

9Y1211109HYS0015US0

Disassembling Hydraulic Pump

1) Disassembling Hydraulic Pump (Power Steering)

1. Remove the pump cover mounting screws (7).
2. Remove the drive gear (6), driven gear (2) and side plate (3) from the casing.

(When reassembling)

- Be careful not to damage the gasket.
- Align the hole of the pump cover (4) and casing 2 (5).
- Install the side plate, noting its location and direction.
- Install the gears, noting its direction.

Tightening torque	Pump cover mounting screw	39.2 to 44.1 N·m 4.0 to 4.5 kgf·m 28.9 to 32.5 lbf·ft
-------------------	---------------------------	---

- (1) Cashing 1
- (2) Driven Gear
- (3) Side Plate
- (4) Pump Cover
- (5) Cashing 2
- (6) Drive Gear
- (7) Screw

9Y1211109HYS0017US0

2) Disassembling Hydraulic Pump (3P Hydraulic System)

1. Remove the pump cover mounting screws (7).
2. Remove the drive gear (6), driven gear (2) and side plate (3) from the casing.

(When reassembling)

- Be careful not to damage the gasket.
- Align the hole of the pump cover (5) and casing 2 (4).
- Install the side plate, noting its location and direction.
- Install the gears, noting its direction.

Tightening torque	Pump cover mounting screw	39.2 to 44.1 N·m 4.0 to 4.5 kgf·m 28.9 to 32.5 lbf·ft
-------------------	---------------------------	---

- (1) Cashing 1
- (2) Driven Gear
- (3) Side Plate
- (4) Cashing 2
- (5) Pump Cover
- (6) Drive Gear
- (7) Screw

9Y1211109HYS0018US0

3) Hydraulic Pump Running-in

After reassembly, perform running-in operation in the following manner, and check the pump for abnormality before use. If the pump temperature should rise noticeably during running-in, recheck should be performed.

1. Install the hydraulic pump to the tractor, and mount the suction pipe and delivery pipe securely.
2. Set the engine speed at 1300 to 1500 min⁻¹ (rpm), and operate the hydraulic pump at no load for about 10 minutes.
3. Set the engine speed at 2000 to 2200 min⁻¹ (rpm), and with the hydraulic pump applied with 2.94 MPa (30 kgf/cm², 427 psi) to 4.90 MPa (50 kgf/cm², 711 psi) pressure, operate it for approx. 15 minutes.
4. With the engine set to maximum speed, fully turn the steering wheel to the left or right, then actuate the relief valve five times for 25 seconds (one time 5 seconds) (for power steering pump.).
5. Stop the engine, then loosen the feedback rod lock nut by 5 turns and screw in the adjusting nut.
6. With the engine set to maximum speed, raise the position control lever and actuate the relief valve five times for 25 seconds (one time 5 seconds) (for **3P** hydraulic pump).

9Y1211109HYS0019US0

(2) Bi-speed Valve

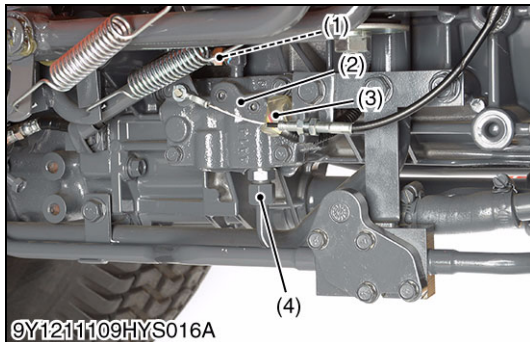

Draining Transmission Fluid

- See page 1-S21, 1-S31.

9Y1211109HYS0020US0

Removing Bi-speed Valve

1. Disconnect the **4P** connector (3) from the bi-speed valve (2).
2. Disconnect the PTO delivery hose (1) and bi-speed delivery pipe (4) from the bi-speed valve (2).
3. Remove the mounting screws and remove the bi-speed valve (2).

(When reassembling)

- Apply liquid gasket (Three Bond 1206C or equivalent) to the bi-speed valve case.

Tightening torque	PTO delivery hose (1) retaining nut	15 to 17 N·m 1.5 to 1.75 kgf·m 10.8 to 12.7 lbf·ft
	Bi-speed delivery pipe (4) retaining nut	30 to 49 N·m 3.0 to 5.0 kgf·m 21.7 to 36.2 lbf·ft
	Bi-speed valve mounting screw	23.5 to 27.5 N·m 2.4 to 2.8 kgf·m 17.4 to 20.3 lbf·ft

- (1) PTO Delivery Hose
- (2) Bi-speed Valve

- (3) **4P** Connector
- (4) Bi-speed Delivery Pipe

9Y1211109HYS0021US0

Bi-speed Valve Assembly

1. The solenoid valve (2), (3) can be removed together with the connector.

- (1) Bi-speed Valve
- (2) Solenoid Valve
(for Bi-speed Clutch)

- (3) Solenoid Valve (for PTO Clutch)
Connector
- (4) Joint

9Y1211109HYS0022US0

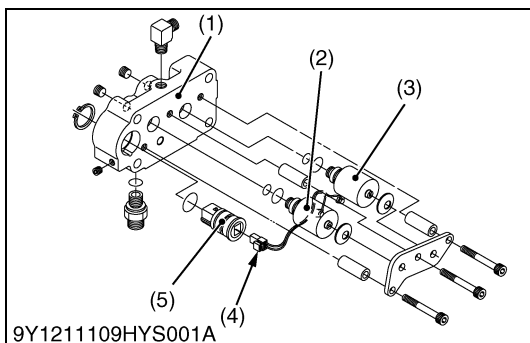

(3) Position Control Valve (3-Point Hydraulic System)

■ IMPORTANT

- The position control valve has been precisely machined, assembled and adjusted.
- It is advisable not to disassemble it, except the unload poppet 1, unload poppet 2 and poppet 1.

9Y1211109HYS0025US0

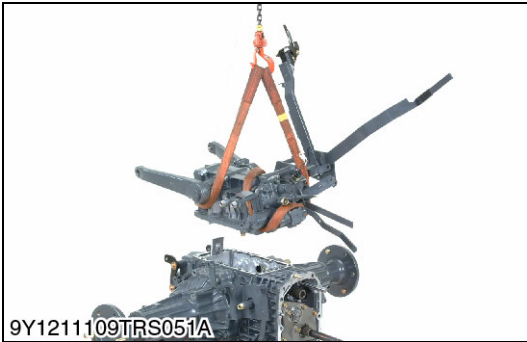

9Y1211109TRS051A

Separating Hydraulic Cylinder

- See page 3-S49.

9Y1211109HYS0026US0

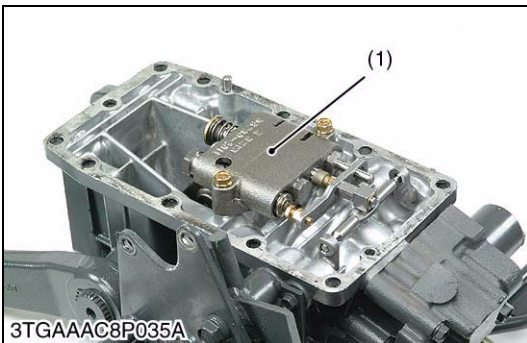

3TGAAAC8P035A

Removing Position Control Valve

1. Remove the position control valve.

(When reassembling)

- Be careful not to damage the O-rings.

Tightening torque	Position control valve mounting screws	19.6 to 23.5 N·m 2.0 to 2.4 kgf·m 14.5 to 17.4 lbf·ft
-------------------	--	---

- (1) Position Control Valve

9Y1211109HYS0027US0

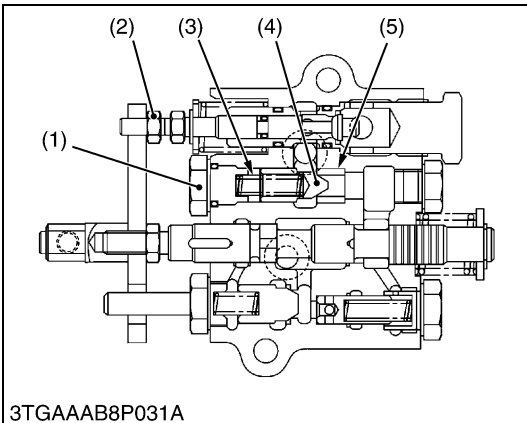

3TGAAAB8P031A

Poppet 1

■ IMPORTANT

- **Never loosen the lock nut (2).**

1. Remove the plug (1).
2. Draw out the spring (3) and poppet 1 (4).

(When reassembling)

- Apply transmission fluid to the O-ring and be careful not to damage it.

- | | |
|--------------|------------------------|
| (1) Plug | (4) Poppet 1 |
| (2) Lock Nut | (5) Check Valve Seat 1 |
| (3) Spring | |

9Y1211109HYS0028US0

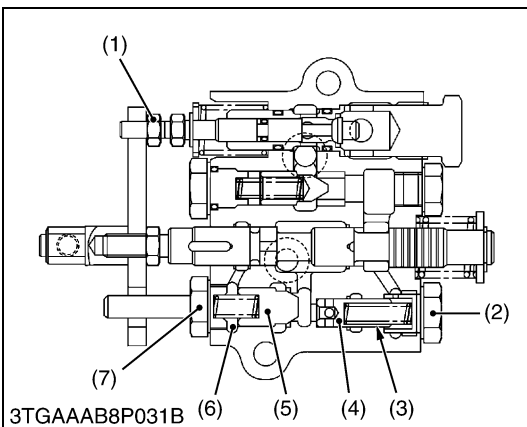

3TGAAAB8P031B

Unload Poppet 1 and Unload Poppet 2

■ IMPORTANT

- **Never loosen the lock nut (1).**

1. Remove the plug (7).
2. Draw out the spring (6) and unload poppet 1 (5).
3. Remove the plug (2).
4. Draw out the spring (3) and unload poppet 2 (4).

(When reassembling)

- Apply transmission fluid to the O-rings and be careful not to damage them.

- | | |
|---------------------|---------------------|
| (1) Lock Nut | (5) Unload Poppet 1 |
| (2) Plug | (6) Spring |
| (3) Spring | (7) Plug |
| (4) Unload Poppet 2 | |

9Y1211109HYS0029US0

(4) Hydraulic Cylinder Cover (3-Point Hydraulic System)

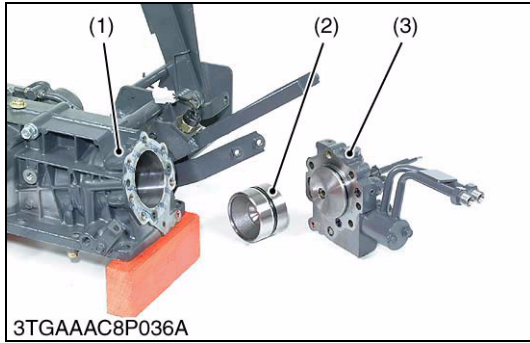

Hydraulic Cylinder Cover and Piston

1. Remove the hydraulic cylinder cover (3).
2. Push out the piston from inside of hydraulic cylinder block (1).

(When reassembling)

- Install the piston (2), noting O-ring (5) and back-up ring (4).
- Replace the thread coated screw (M8) with a new one.

Tightening torque	Hydraulic cylinder cover mounting screws (M10)	39.2 to 44.1 N·m 4.0 to 4.5 kgf·m 28.9 to 32.5 lbf·ft
	Hydraulic cylinder cover mounting screw (M8)	17.7 to 20.6 N·m 1.8 to 2.1 kgf·m 13.0 to 15.2 lbf·ft

- (1) Hydraulic Cylinder Block
- (2) Piston
- (3) Hydraulic Cylinder Cover
- (4) Back-up Ring
- (5) O-ring

9Y1211109HYS0030US0

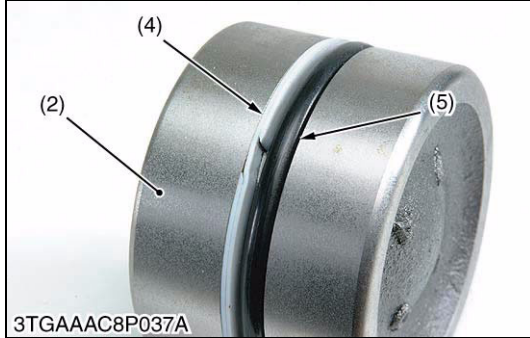

Lowering Speed Adjusting Valve

1. Remove the split pin (12) and remove the washer (11) and spring (2).
2. Remove the internal snap ring (3) and draw out the adjusting shaft (1).
3. Remove the external snap ring (9) and remove the adjusting collar (6), spring (7) and washer (8).

(When reassembling)

- Apply transmission oil to the O-rings and not give damage to them.

- (1) Adjusting Shaft
- (2) Spring
- (3) Internal Snap Ring
- (4) Straight Pin
- (5) O-ring
- (6) Adjusting Collar
- (7) Spring
- (8) Washer
- (9) External Snap Ring
- (10) Washer
- (11) Washer
- (12) Split Pin

9Y1211109HYS0031US0

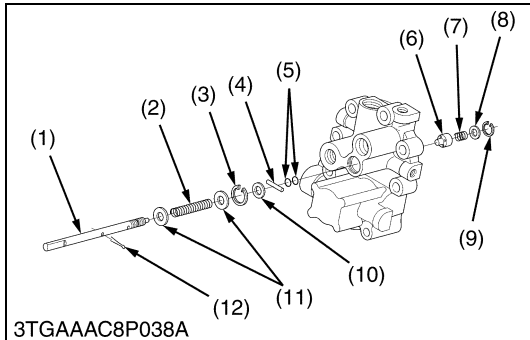

Relief Valve

1. Remove the plug (8).
2. Remove the washer (5), shims (6), spring (4), poppet (3) and valve seat (2).

(When reassembling)

- Apply transmission fluid to the O-ring and be careful not to damage it.

Tightening torque	Relief valve plug	39.2 to 49.0 N·m 4.0 to 5.0 kgf·m 28.9 to 36.2 lbf·ft
-------------------	-------------------	---

- (1) Hydraulic Cylinder Cover
- (2) Valve Seat
- (3) Poppet
- (4) Spring
- (5) Washer
- (6) Shim
- (7) O-ring
- (8) Plug

9Y1211109HYS0032US0

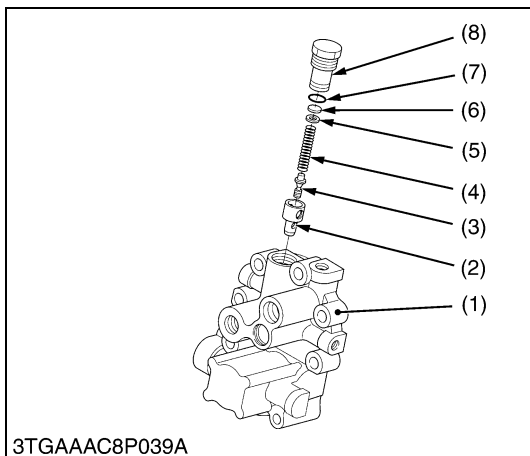

(5) Hydraulic Cylinder (3-Point Hydraulic System)

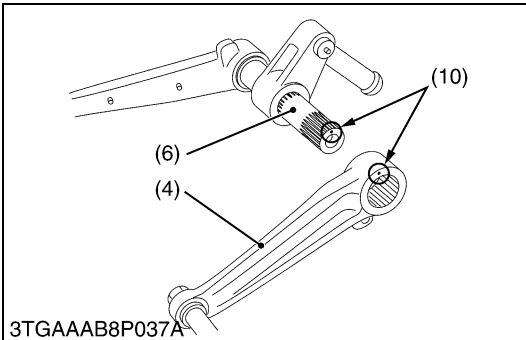
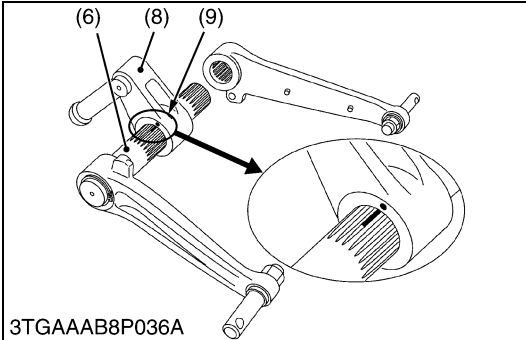
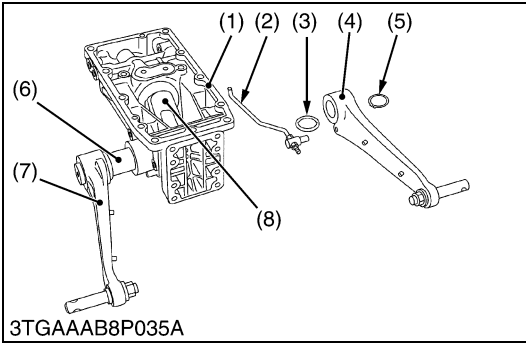

Lift Arm and Hydraulic Arm Shaft

1. Remove the position control rod (2).
2. Remove the external snap ring and tap out the lift arm L.H. (4).
3. Pull out the lift arm R.H. (7) and hydraulic arm shaft (6) as a unit.
4. Remove the hydraulic arm (8) and hydraulic rod as a unit.

(When reassembling)

- Apply molybdenum disulfide (Three Bond 1901 or equivalent) to the contact surface of the hydraulic arm and hydraulic rod.
- Align the alignment marks (9) of the hydraulic arm (8) and hydraulic arm shaft (6).
- Align the alignment marks (10) of the lift arm (4) and hydraulic arm shaft (6).
- Apply molybdenum disulfide (Three Bond 1901 or equivalent) to the right and left bushings of hydraulic cylinder block and O-rings (3).
- Be careful not to damage the O-rings (3).

- | | |
|------------------------------|--|
| (1) Hydraulic Cylinder Block | (7) Lift Arm R.H. |
| (2) Position Control Rod | (8) Hydraulic Arm |
| (3) O-ring | (9) Alignment Mark (Hydraulic Arm Shaft and Hydraulic Arm) |
| (4) Lift Arm L.H. | (10) Alignment Mark (Hydraulic Arm Shaft and Lift Arm) |
| (5) External Snap Ring | |
| (6) Hydraulic Arm Shaft | |

9Y1211109HYS0033US0

(6) Auxiliary Control Valve

Removing Auxiliary Control Valve

- See page 3-S24, 3-S36.

9Y1211109HYS0034US0

Auxiliary Control Valve

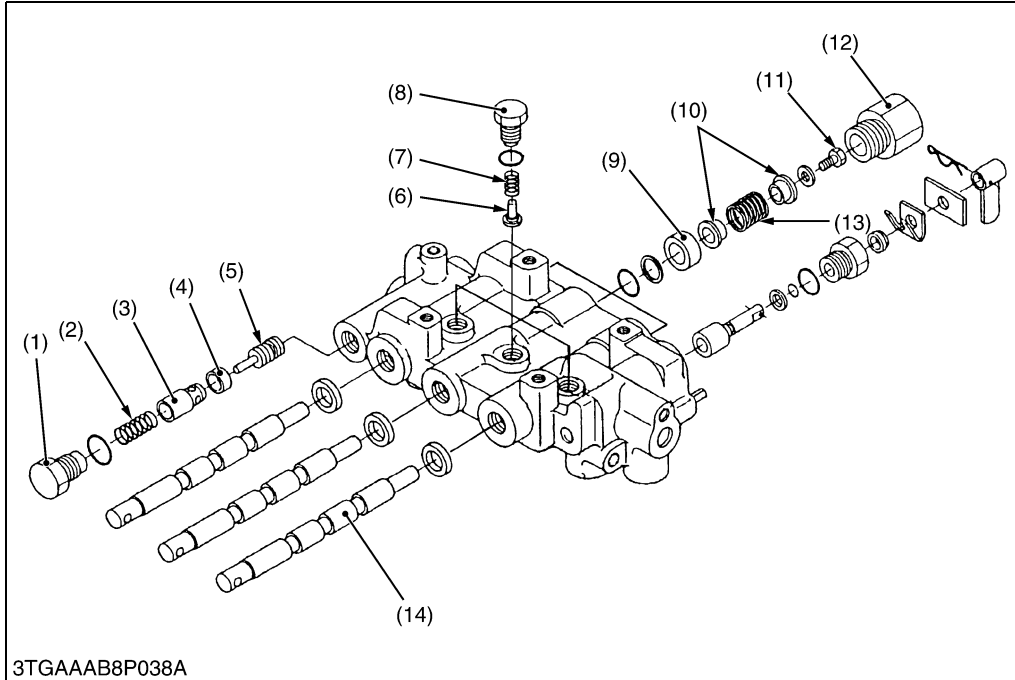

- (1) Plug
- (2) Spring
- (3) Poppet
- (4) Poppet Seat
- (5) Pilot Valve
- (6) Check Valve
- (7) Spring
- (8) Plug
- (9) Collar
- (10) Collar Retainer
- (11) Return Spring Mounting Screw
- (12) Plug
- (13) Return Spring
- (14) Spool

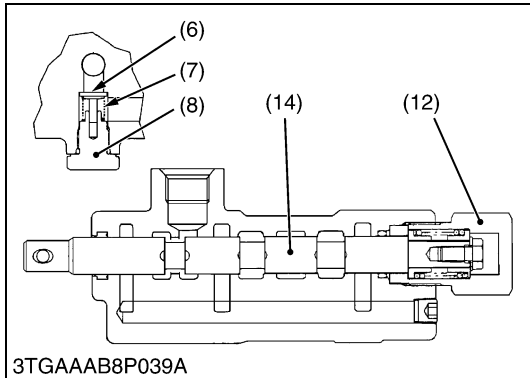

■ Spool and Check Valve

1. Remove the plug (12) and draw out the spool (14) as a unit.
2. Remove the plug (8) and draw out the spring (7) and check valve (6).

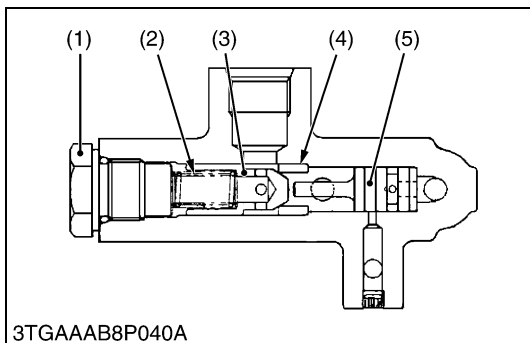

■ Unload Valve

1. Remove the plug (1) and draw out the spring (2), poppet (3), poppet seat (4) and pilot valve (5).

9Y1211109HYS0035US0

[3] SERVICING

(1) Hydraulic Pump (Power Steering and 3-Point Hydraulic System)



Housing Bore (Depth of Scratch)

1. Check for the scratch on the interior surface of the housing caused by the gear.
2. If the scratch reaches more than half the area of the interior surface of the housing, replace at pump assembly.
3. Measure the housing I.D. where the interior surface is not scratched, and measure the housing I.D. where the interior surface is scratched.
4. If the values obtained in the two determinations differ by more than the allowable limit, replace the hydraulic pump as a unit.

(Reference)

- Use a cylinder gauge to measure the housing I.D.

Depth of scratch	Allowable limit	0.09 mm 0.0035 in.
------------------	-----------------	-----------------------

9Y1211109HYS0036US0



Clearance between Bushing and Gear Shaft

1. Measure the gear shaft O.D. with an outside micrometer.
2. Measure the bushing I.D. with an inside micrometer or cylinder gauge, and calculate the clearance.
3. If the clearance exceeds the allowable limit, replace the gear shaft and the bushing as a unit.

Clearance between bushing and gear shaft	Factory specification	0.020 to 0.081 mm 0.0008 to 0.0032 in.
	Allowable limit	0.15 mm 0.0059 in.

Gear shaft O.D.	Factory specification	14.970 to 14.980 mm 0.5894 to 0.5898 in.
Bushing I.D.	Factory specification	15.000 to 15.051 mm 0.5906 to 0.5926 in.

9Y1211109HYS0037US0



Side Plate Thickness

1. Measure the side plate thickness with an outside micrometer.
2. If the thickness is less than the allowable limit, replace it.

Side plate thickness	Factory specification	2.48 to 2.50 mm 0.0976 to 0.0984 in.
	Allowable limit	2.40 mm 0.0945 in.

9Y1211109HYS0038US0

(2) Hydraulic Cylinder

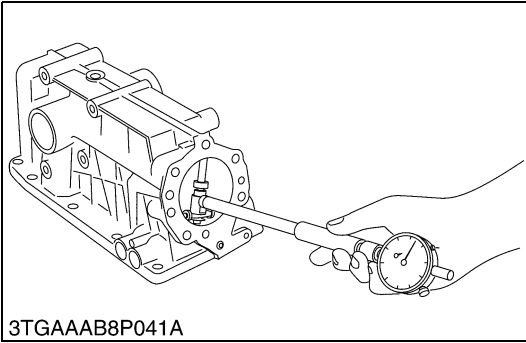

Hydraulic Cylinder Bore

1. Check the cylinder internal surface for scoring or damage.
2. Measure the cylinder I.D. with a cylinder gauge.
3. If the measurement exceeds the allowable limit, replace.

Cylinder bore I.D.	Factory specification	75.06 to 75.10 mm 2.9551 to 2.9567 in.
	Allowable limit	75.20 mm 2.9606 in.

9Y1211109HYS0042US0

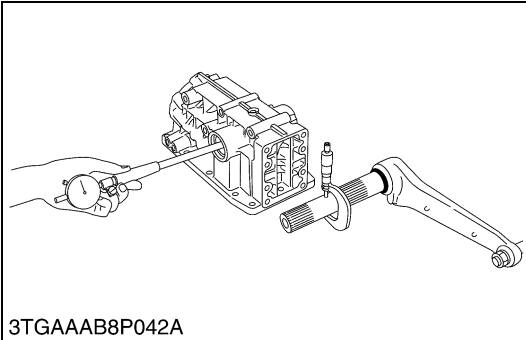

Clearance between Hydraulic Arm Shaft and Bushing

1. Measure the hydraulic arm shaft O.D. with an outside micrometer.
2. Measure the bushing I.D. with a cylinder gauge.
3. If the clearance exceeds the allowable limit, replace.

■ **NOTE**

- If replace the bushings, be sure to use the hydraulic arm shaft bushing replacing tool. (See page G-49.)

Clearance between hydraulic arm shaft and bushing	Factory specification	Right	0.120 to 0.210 mm 0.0047 to 0.0083 in.
		Left	0.090 to 0.200 mm 0.0035 to 0.0079 in.
	Allowable limit		0.30 mm 0.0118 in.

Hydraulic arm shaft O.D.	Factory specification	Right	37.795 to 37.820 mm 1.4880 to 1.4890 in.
		Left	34.925 to 34.950 mm 1.3750 to 1.3760 in.
Bushing I.D.	Factory specification	Right	37.940 to 38.005 mm 1.4937 to 1.4963 in.
		Left	35.040 to 35.125 mm 1.3795 to 1.3829 in.

9Y1211109HYS0043US0

9 ELECTRICAL SYSTEM

MECHANISM

CONTENTS

1. WIRING DIAGRAM.....	9-M1
[1] ROPS MODEL.....	9-M1
[2] CABIN MODEL.....	9-M2
2. STARTING SYSTEM.....	9-M4
[1] ROPS MODEL.....	9-M4
[2] CABIN MODEL.....	9-M6
(1) Glow Control System.....	9-M7
[3] OPERATOR PRESENCE CONTROL.....	9-M8
(1) Operator Presence Control System.....	9-M8
(2) Engine Starting Conditions and Automatic Engine Stop.....	9-M10
3. CHARGING SYSTEM.....	9-M11
4. LIGHTING SYSTEM.....	9-M12
[1] FLASHER UNIT.....	9-M13
[2] BRAKE LIGHT SWITCH.....	9-M14
5. BI-SPEED TURN SYSTEM.....	9-M15
[1] ELECTRICAL CIRCUIT.....	9-M15
[2] SYSTEM OUTLINE.....	9-M16
[3] BI-SPEED TURN SYSTEM.....	9-M17
(1) Feature.....	9-M17
(2) Related Parts and Arrangement.....	9-M17
6. INSTRUMENT PANEL.....	9-M19
[1] SYSTEM OUTLINE.....	9-M19
[2] LCD MONITOR INDICATOR.....	9-M19

1. WIRING DIAGRAM

[1] ROPS MODEL

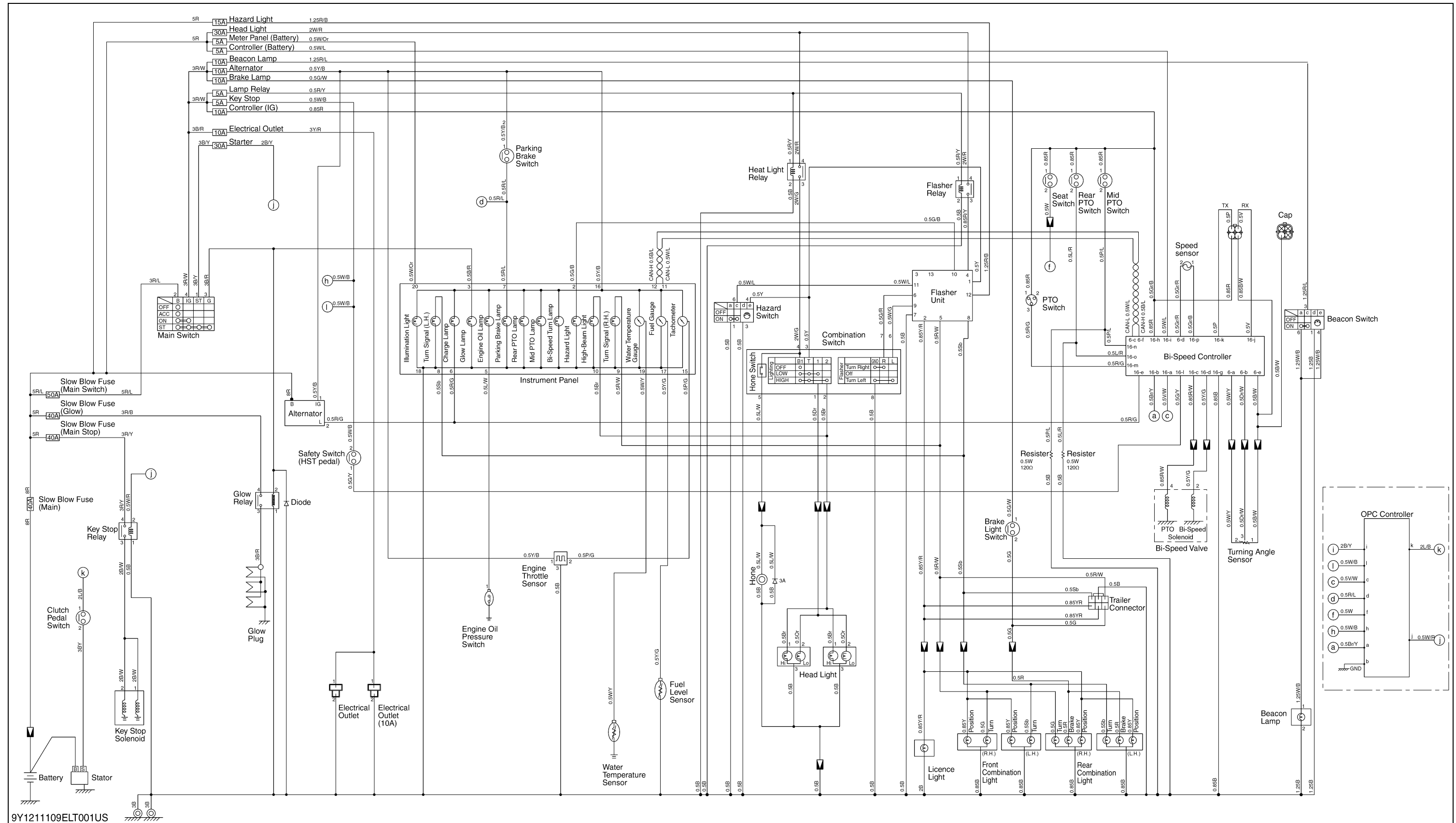

9Y1211109ELT001US

[2] CABIN MODEL

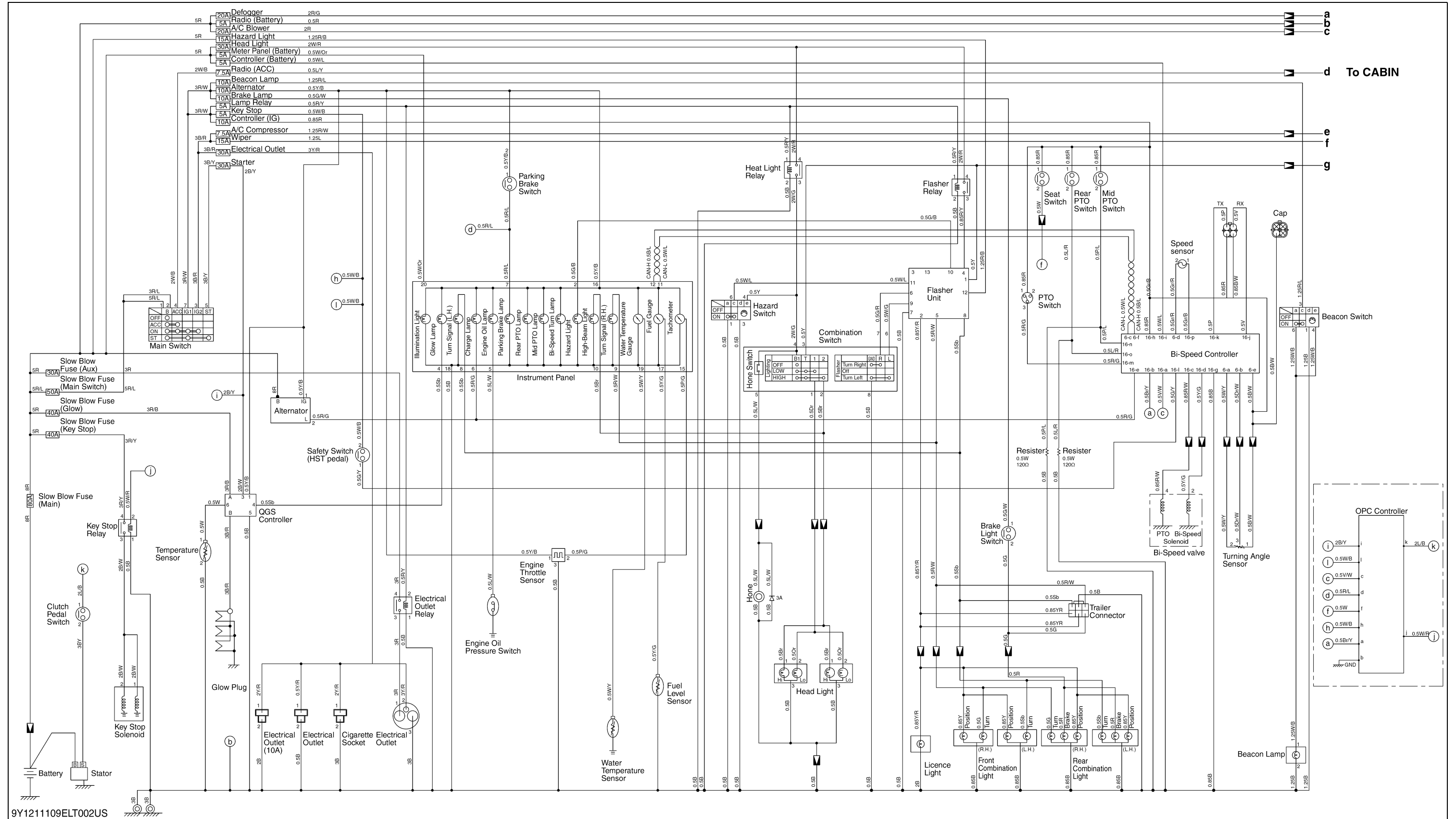

9Y1211109ELT002US

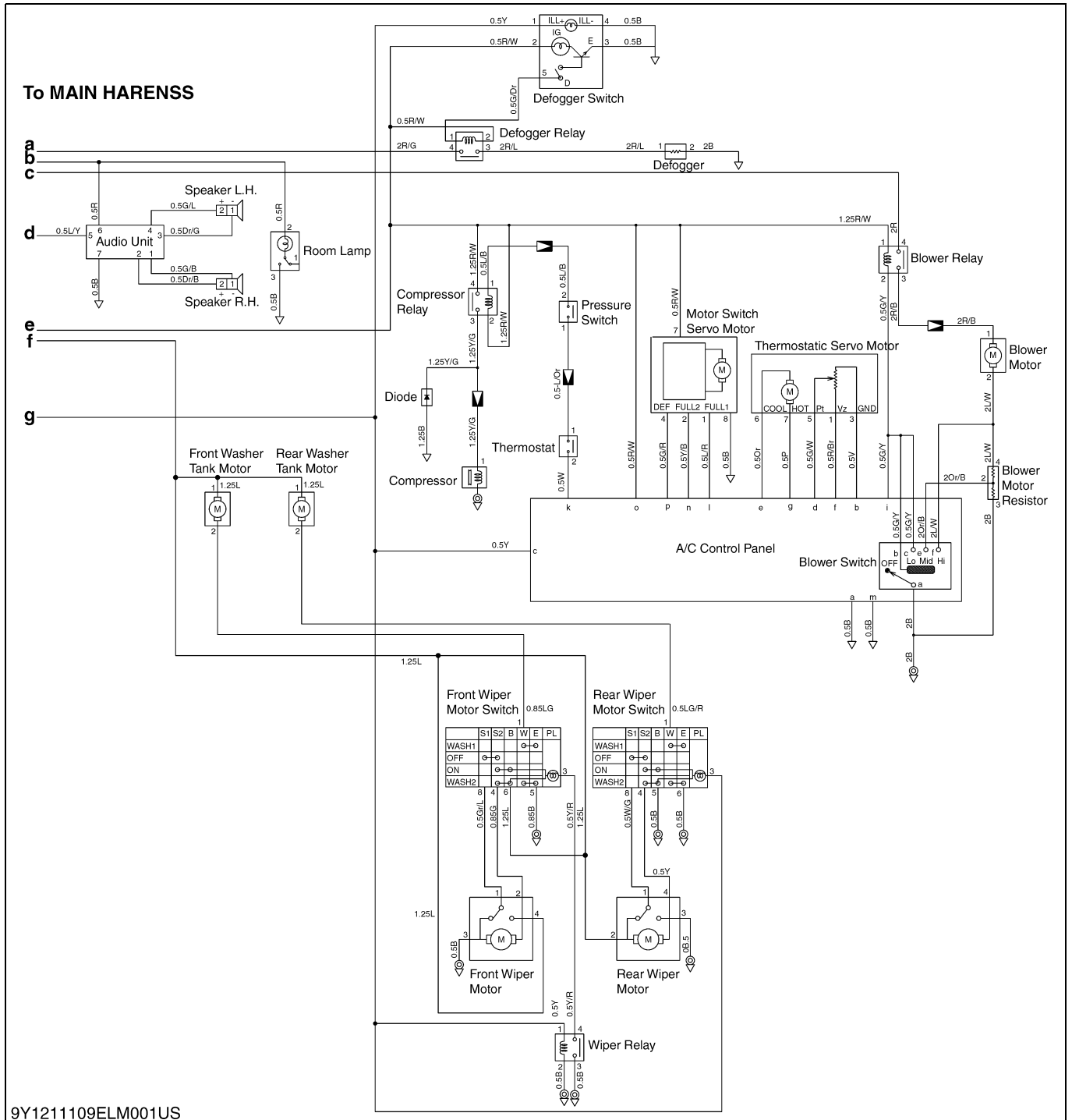

9Y1211109ELM001US

9Y1211109ELM0021US0

2. STARTING SYSTEM

[1] ROPS MODEL

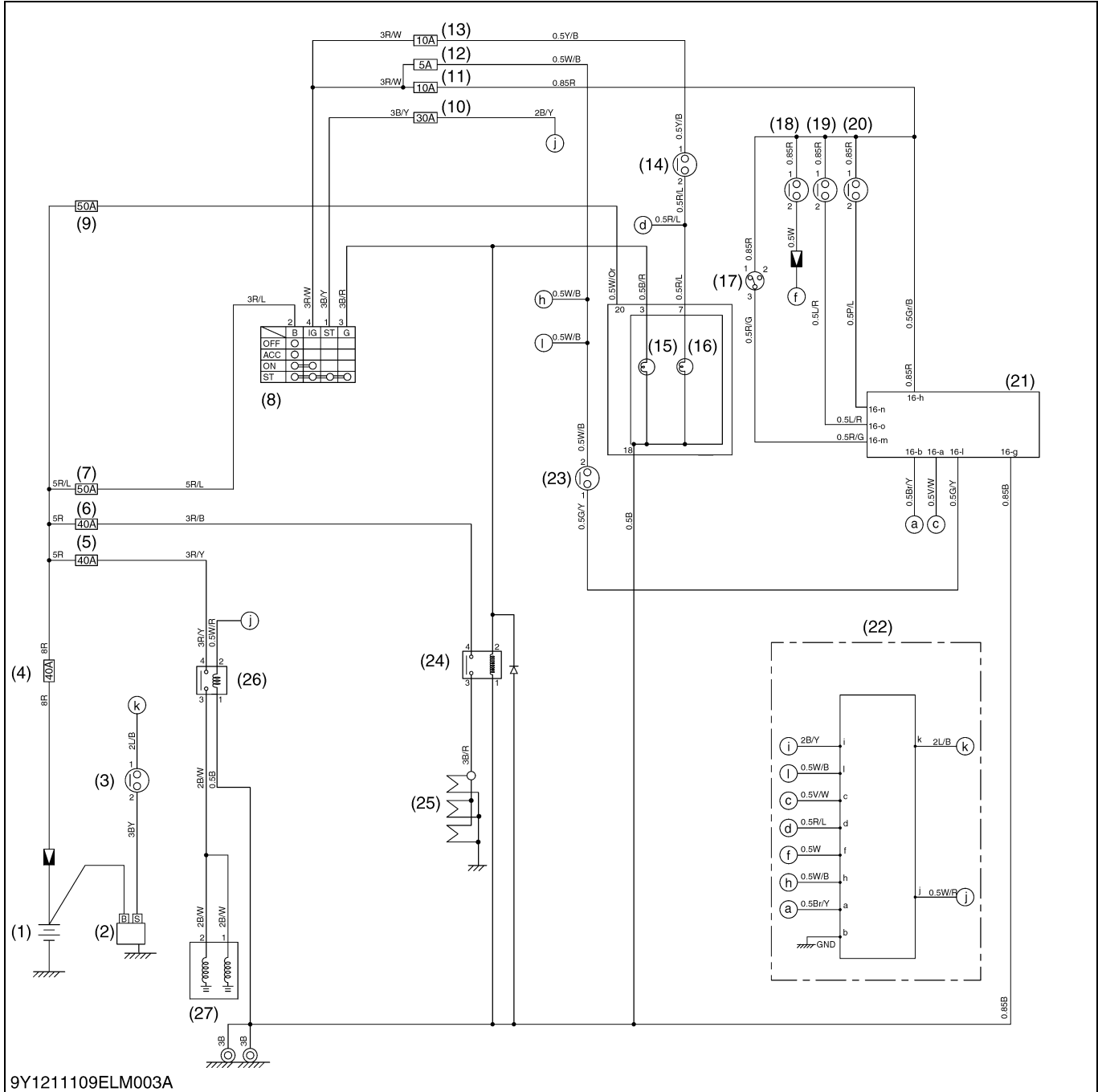

9Y1211109ELM003A

- | | | | |
|--------------------------|---------------------------|--------------------------------|---------------------------------------|
| (1) Battery | (8) Mains Switch | (15) Glow Indicator Lamp | (22) OPC Controller |
| (2) Starter | (9) Fuse (5A) | (16) Parking Brake Lamp | (23) Speed Control Pedal Switch (HST) |
| (3) Clutch Pedal Switch | (10) Fuse (30A) | (17) PTO Clutch Control Switch | (24) Glow Relay |
| (4) Slow Blow Fuse (40A) | (11) Fuse (10A) | (18) Seat Switch | (25) Glow Plug |
| (5) Slow Blow Fuse (40A) | (12) Fuse (5A) | (19) Rear PTO Switch | (26) Key Stop Relay |
| (6) Slow Blow Fuse (40A) | (13) Fuse (10A) | (20) Mid PTO Switch | (27) Key Stop Solenoid Relay |
| (7) Slow Blow Fuse (50A) | (14) Parking Brake Switch | (21) Bi-speed Controller | |

(To be continued)

(Continued)

When the main switch is turned to the **PREHEAT** position, the terminal **B** is connected to the terminals **G** and **IG**. The glow plugs become red-hot, and at the same time, glow indicator lamp lights on.

When the main switch is turned to the **START** position with the safety switches on and the PTO clutch control switch off, the terminal **B** is connected to the terminals **G**, **ST** and **IG**. Consequently, battery current flows to the starter motor and start the engine.

The main switch automatically returns to the **ON** position, the terminal **B** is connected only to the terminal **IG**, thereby causing the starting circuit to be opened, stopping the starter motor.

When the main switch turned from the **ON** position to the **OFF** position, the engine stop solenoid moves the fuel injection pump control rack to the "No Fuel Injection" position and stop the engine. The engine stop solenoid is a "Energized to Run Type".

9Y1211109ELM0004US0

[2] CABIN MODEL

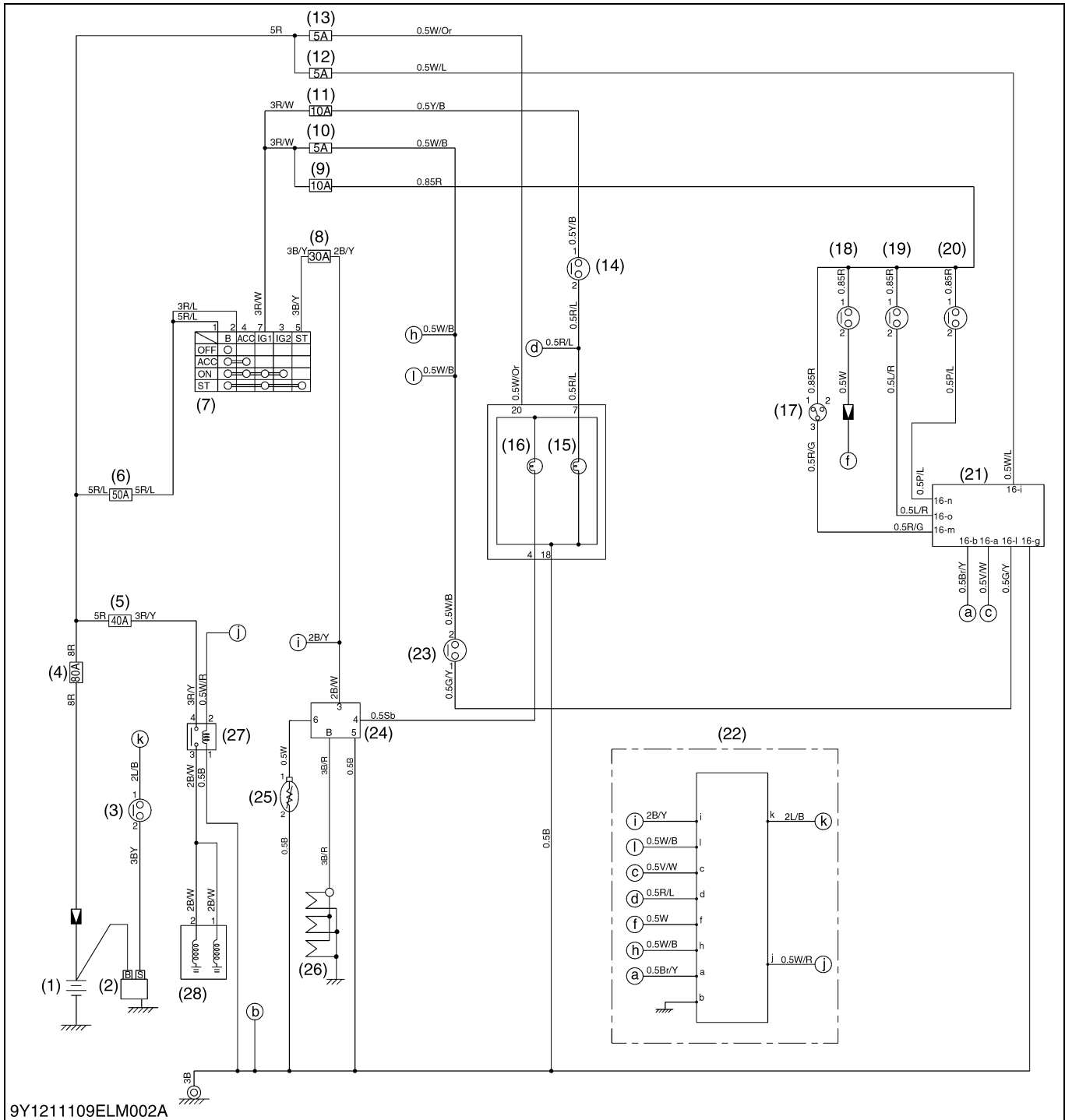

9Y1211109ELM002A

- | | | | |
|--------------------------|---------------------------|--------------------------------|---------------------------------------|
| (1) Battery | (9) Fuse (10A) | (16) Glow Indicator Lamp | (23) Speed Control Pedal Switch (HST) |
| (2) Starter | (10) Fuse (5A) | (17) PTO Clutch Control Switch | (24) QGS Controller |
| (3) Clutch Pedal Switch | (11) Fuse (10A) | (18) Seat Switch | (25) Coolant Temperature Sensor |
| (4) Slow Blow Fuse (40A) | (12) Fuse (5A) | (19) Rear PTO Switch | (26) Glow Plug |
| (5) Slow Blow Fuse (40A) | (13) Fuse (5A) | (20) Mid PTO Switch | (27) Key Stop Relay |
| (6) Slow Blow Fuse (40A) | (14) Parking Brake Switch | (21) Bi-speed Controller | (28) Key Stop Solenoid |
| (7) Mains Switch | (15) Parking Brake Lamp | (22) OPC Controller | |
| (8) Fuse (30A) | | | |

9Y1211109ELM0007US0

(1) Glow Control System

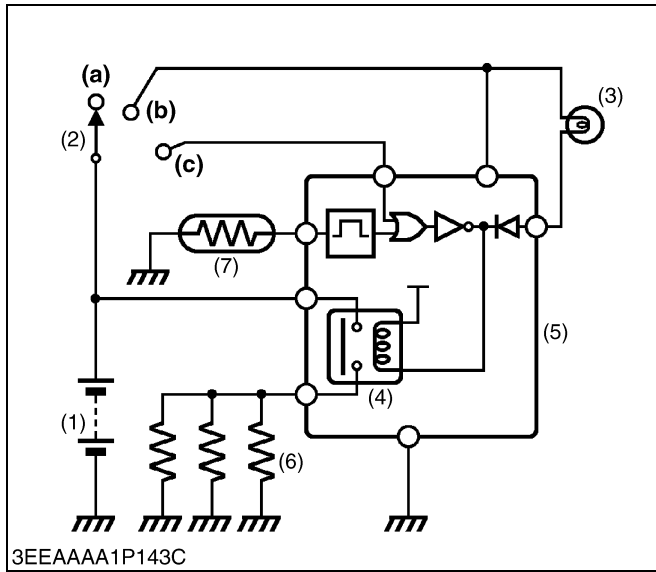

STW34, 37 and 40 Cabin Model Tractor are equipped quick glow system (QGS) to control energizing time to the glow plugs (6) by means of coolant temperature of the engine.

This system makes it easy for the operator to start the engine even when it is in cold season, because starting preparation can be completed if it is confirmed that the glow lamp (3) is turned off. This system consists of main switch, glow lamp, glow relay, glow controller, coolant temperature sensor and glow plug.

Main Switch	Glow Relay	Glow Lamp	Glow Plug
OFF	OFF	OFF	OFF
ON	ON	ON	ON
START	ON	ON	ON

- (1) Battery
- (2) Main Switch
- (3) Glow Lamp
- (4) Glow Relay
- (5) Glow Controller
- (6) Glow Plug
- (7) Coolant Temperature Sensor
- (a) "OFF" Position
- (b) "ON" Position
- (c) "START" Position

9Y1211109ELM0018US0



QGS Controller

When the main switch is turned on, the QGS controller (1) detects the coolant temperature by means of the coolant temperature sensor (2), and controls the energizing time to the glow plugs and glow lamp according to the detected coolant temperature.

The relation between the coolant temperature and the energizing time is as shown in the table.

Coolant Temperature	Energizing Time
-25 °C (-13 °F)	4.8 to 7.2 second
0 °C (-32 °F)	2.8 to 4.2 second
60 °C (140 °F)	1.4 to 2.2 second

- (1) QGS Controller
- (2) Coolant Temperature Sensor

9Y1211109ELM0022US0

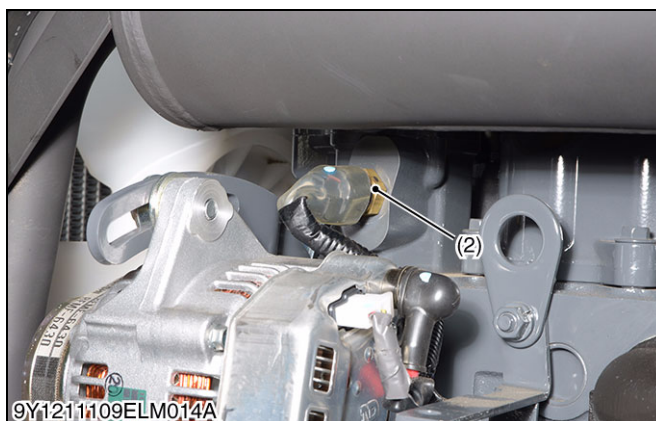

[3] OPERATOR PRESENCE CONTROL

(1) Operator Presence Control System

STW 34, 37, 40 are configured with an "Operator Presence Control (OPC)" system to control engine starting automatically stopping.

This OPC system mainly consists of controller and engine starting / stopping control switches such as the speed control pedal switch (HST), the seat switch, the rear PTO switch, the mid PTO switch and the parking brake switch.

Main parts regarding OPC system are laid out as shown in the electrical circuit.

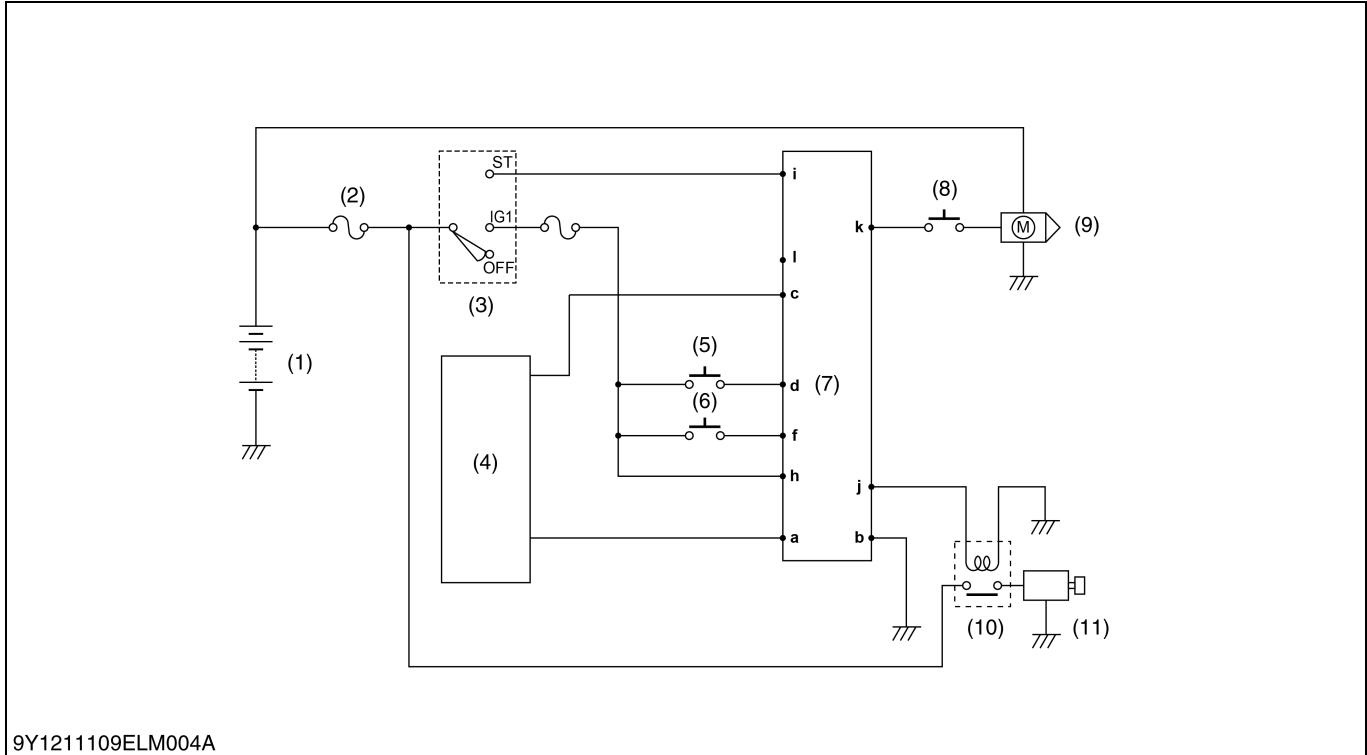

9Y1211109ELM004A

- | | | | |
|--------------------|--------------------------|--------------------|------------------------------|
| (1) Battery | (4) Bi-speed Controller | (7) OPC Controller | (10) Key Stop Solenoid Relay |
| (2) Slow Blow Fuse | (5) Parking Brake Switch | (8) Clutch Pedal | (11) Key Stop Solenoid |
| (3) Main Switch | (6) Seat Switch | (9) Starter Motor | |

9Y1211109ELM0008US0

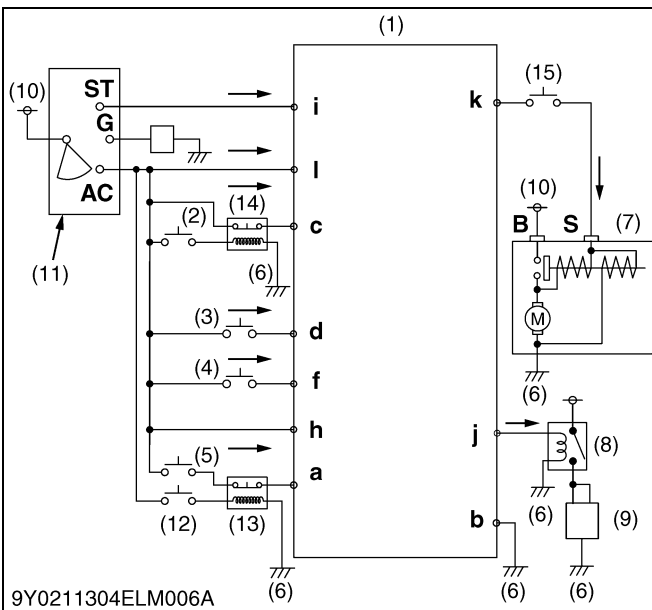
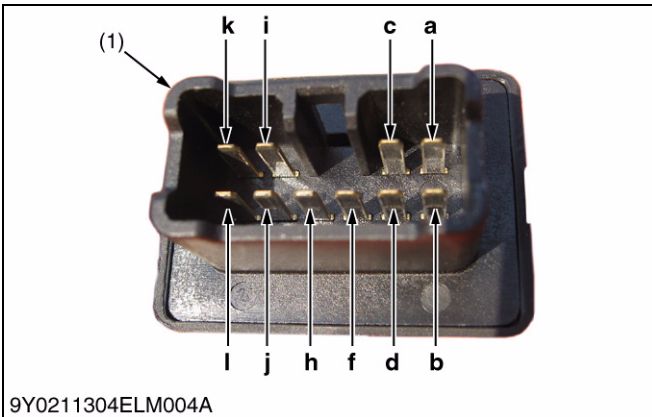

OPC Controller

A controller (1) is located inside under the steering wheel.

The current from the main switch (11), safety switches flows to controller (1).

The controller (1) receives a current as data, processes the data, and sends out current computing results to starter motor (7), key stop solenoid relay (8), and key stop solenoid (9).

The OPC controller (1) controls engine starting and engine stopping.

The current flows from battery to controller (1).

The current from switches such as rear PTO switch (2), mid PTO switch (12), parking brake switch (3), seat switch (4) and speed control pedal switch (5), flows to the controller (1).

After starting the engine, the controller supplies current to starter motor (7) S terminal or key stop solenoid relay (8).

The controller (1) receives data, processes the data, and sends out the computing results.

The controller (1) receives data from safety switches, processes the data inside the controller itself, and sends out the computing results to starter motor (7) for engine starting, and key stop solenoid relay (8) for engine stopping.

The controller (1) is configured with a relay timer in the controller (1) unit to hold fuel cut signal from the controller (1) unit to key stop solenoid (9) for about 1 second.

- | | |
|--------------------------------------|--------------------------|
| (1) OPC Controller | (9) Key Stop Solenoid |
| (2) Rear PTO Switch | (10) Battery |
| (3) Parking Brake Switch | (11) Main Switch |
| (4) Seat Switch | (12) Mid PTO Switch |
| (5) Speed Control Pedal Switch (HST) | (13) Mid PTO Relay |
| (6) Body Earth | (14) Rear PTO Relay |
| (7) Starter Motor | (15) Clutch Pedal Switch |
| (8) Key Stop Solenoid Relay | |

9Y1211109ELM0009US0

(2) Engine Starting Conditions and Automatic Engine Stop

When the following conditions become complete, electric current (12 V) reaches starter **S** terminal through operator presence controller main switch and the engine can be started.

9Y1211109ELM0010US0

Engine Starting Conditions and Engine Auto-stop Conditions

	Speed Control Pedal Switch (HST)	Rear PTO Switch	Mid PTO Switch	Parking Brake Switch	Seat Switch	Engine Start	Key Stop Output
	Neutral: on Forward and Reverse: off	Disengaged: off Engaged: on	Disengaged: off Engaged: on	Lock: on Unlock: off	Sit: on Stand: off	Engine Start: on Engine must not Start: None	Engine Stop: on Engine dose not Stop: off
1	on	off	on	on	on	None	off
2	on	off	on	off	on	None	off
3	on	off	on	on	off	None	on
4	on	off	on	off	off	None	on
5	on	off	off	on	on	on	on
6	on	off	off	off	on	on	on
7	on	off	off	on	off	on	on
8	on	off	off	off	off	on	on
9	on	on	on	on	on	None	off
10	on	on	on	off	on	None	off
11	on	on	on	on	off	None	on
12	on	on	on	off	off	None	on
13	on	on	off	on	on	None	off
14	on	on	off	off	on	None	off
15	on	on	off	on	off	None	off
16	on	on	off	off	off	None	on
17	off	off	on	on	on	None	off
18	off	off	on	off	on	None	off
19	off	off	on	on	off	None	on
20	off	off	on	off	off	None	on
21	off	off	off	on	on	None	off
22	off	off	off	off	on	None	off
23	off	off	off	on	off	None	on
24	off	off	off	off	off	None	on
25	off	on	on	on	on	None	off
26	off	on	on	off	on	None	off
27	off	on	on	on	off	None	on
28	off	on	on	off	off	None	on
29	off	on	off	on	on	None	off
30	off	on	off	off	on	None	off
31	off	on	off	on	off	None	on
32	off	on	off	off	off	None	on

9Y1211109ELM0011US0

3. CHARGING SYSTEM

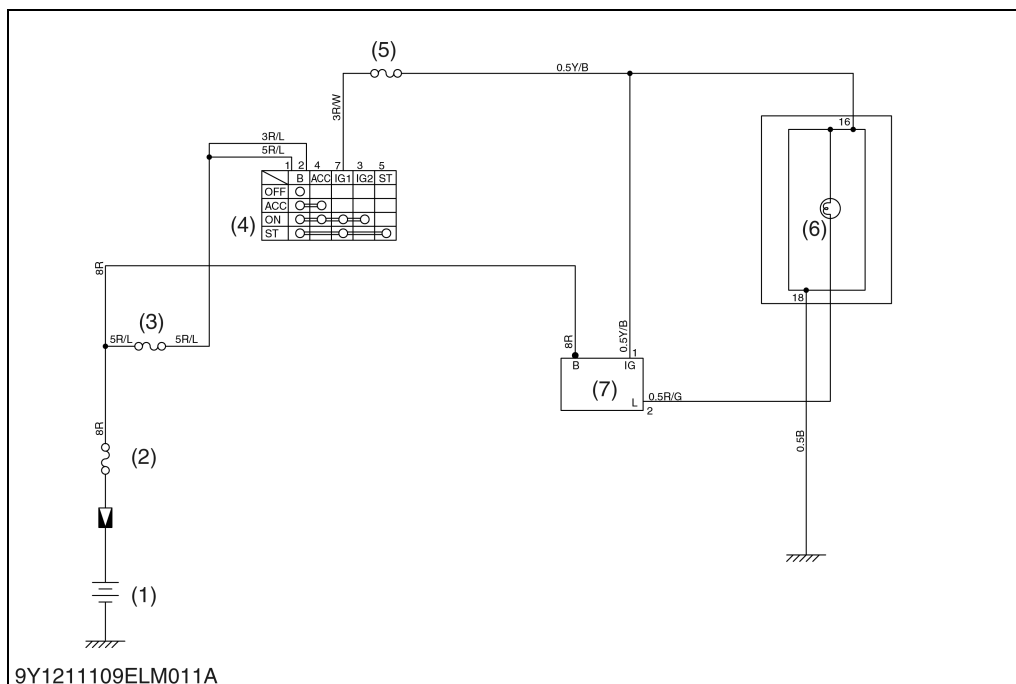

- (1) Battery
- (2) Slow Blow Fuse (Main)
- (3) Slow Blow Fuse (Main Switch)
- (4) Main Switch
- (5) Fuse
- (6) Charge Lamp
- (7) Alternator

9Y1211109ELM011A

The charging system supplies electric power for various devices and also charges the battery while the engine runs.

9Y1211109ELM0012US0

4. LIGHTING SYSTEM

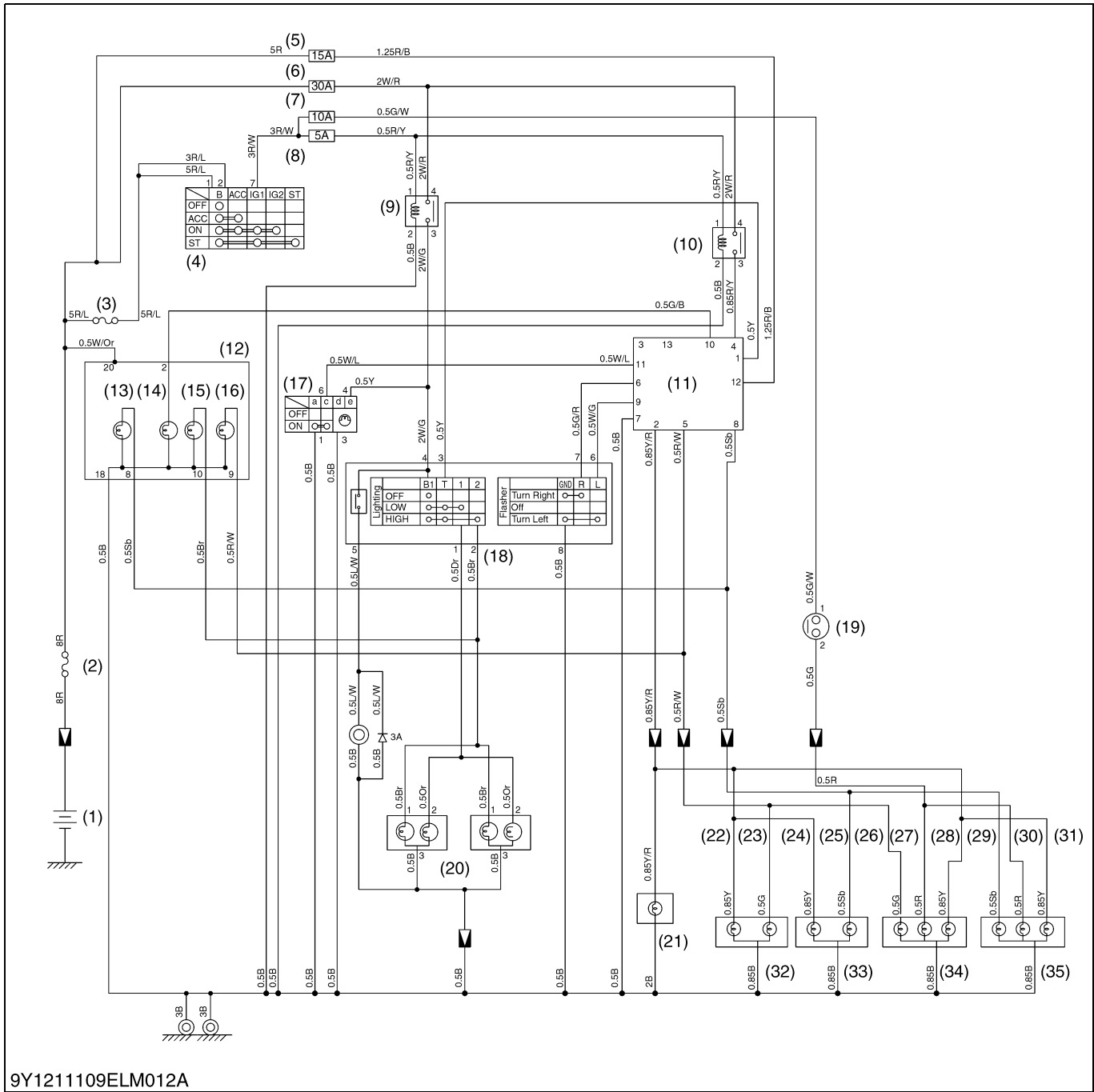

9Y1211109ELM012A

- | | | | |
|----------------------------------|-------------------------|-----------------------------|------------------------------------|
| (1) Battery | (10) Flasher Relay | (19) Brake Light Switch | (28) Position Light (Right) |
| (2) Fuse (Main) | (11) Flasher Unit | (20) Head Light | (29) Turn Light (Left) |
| (3) Slow Blow Fuse (Main Switch) | (12) Instrument Panel | (21) Licence Light | (30) Brake Light (Left) |
| (4) Main Switch | (13) Turn Signal (L.H) | (22) Position Light (Right) | (31) Position Light (Left) |
| (5) Fuse (Hazard) | (14) Hazard Lamp | (23) Turn Light (Right) | (32) Front Combination Light (R.H) |
| (6) Fuse (Head Light) | (15) High Beam Lamp | (24) Position Light (Left) | (33) Front Combination Light (L.H) |
| (7) Fuse (Break Lamp) | (16) Turn Signal (R.H) | (25) Turn Light (Left) | (34) Rear Combination Light (R.H.) |
| (8) Fuse (Key Stop) | (17) Hazard Switch | (26) Turn Light (Right) | (35) Rear Combination Light (L.H.) |
| (9) Head Light Relay | (18) Combination Switch | (27) Brake Light (Right) | |

The lighting system consists of main switch, combination switch, hazard switch, flasher unit, brake light switch, head light, combination light, brake light, etc..

9Y1211109ELM0013US0

[1] FLASHER UNIT

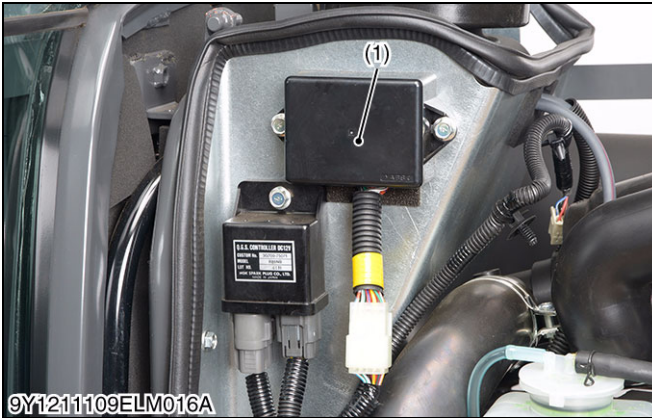

9Y1211109ELM016A

- The function of flasher unit is as follows.
1. The flasher unit blinks the turn signal light (3), (4) and hazard indicator light (2) when the hazard switch (9) is turned on.
 2. The flasher unit blinks the turn signal light (3) or (4), when the turn signal switch (11) is turned clockwise or counterclockwise.
 3. The flasher unit lights the position light (5) when the light switch (14) is turned on (Lo or Hi).
 4. The flasher unit lights the position light (5) when the position light switch is turned on.
 5. The blinking frequency is 60 to 120 times per minutes.

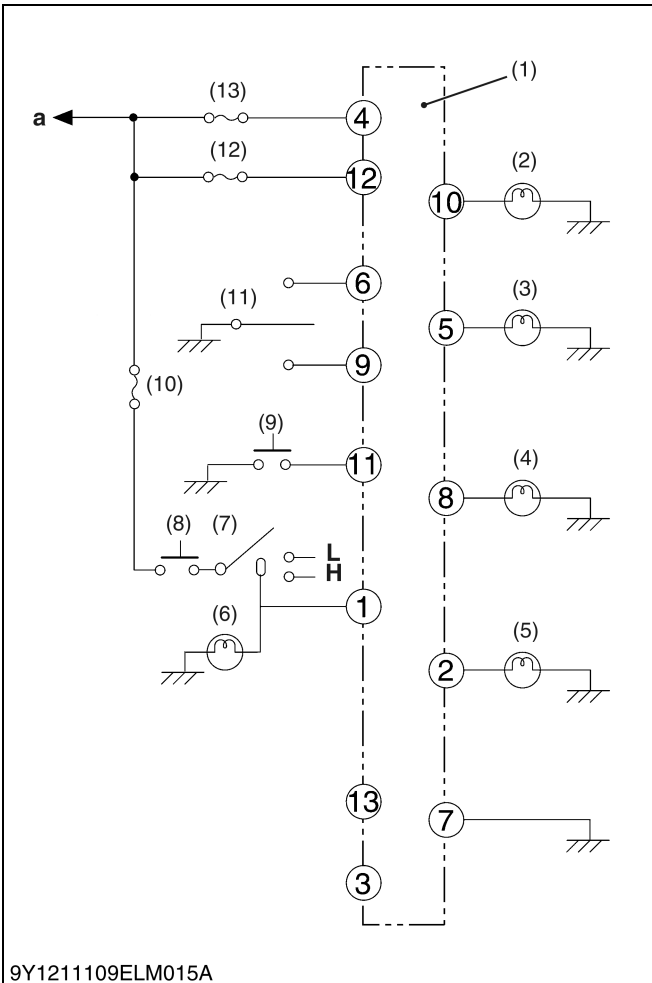

9Y1211109ELM015A

- | | |
|-------------------------------|-------------------------|
| (1) Flasher Unit | (9) Hazard Switch |
| (2) Hazard Indicator Light | (10) Fuse |
| (3) Turn Signal Light (Right) | (11) Turn Signal Switch |
| (4) Turn Signal Light (Left) | (12) Fuse |
| (5) Position Light | (13) Flasher Relay |
| (6) Hazard Switch Lamp | |
| (7) Head Light Switch | |
| (8) Head Light Relay | |
- A: To Battery**

9Y1211109ELM0014US0

[2] BRAKE LIGHT SWITCH

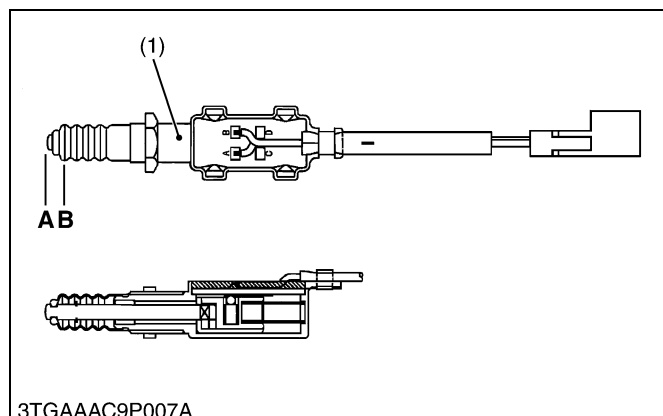

When the brake pedal is not operated, the brake switch is pushed with the lever (2), and turned off.

The lever (2) rotates counterclockwise by the brake link (3) when both brake pedals are depressed at the same time. Then, the brake light switch (1) turns on and the brake lamp lights.

- (1) Brake Light Switch
- (2) Lever
- (3) Brake Link

A: ON Position
B: OFF Position

9Y1211109ELM0015US0

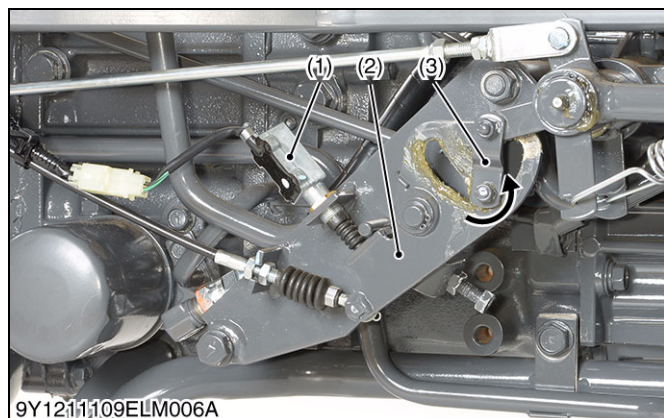

5. BI-SPEED TURN SYSTEM

[1] ELECTRICAL CIRCUIT

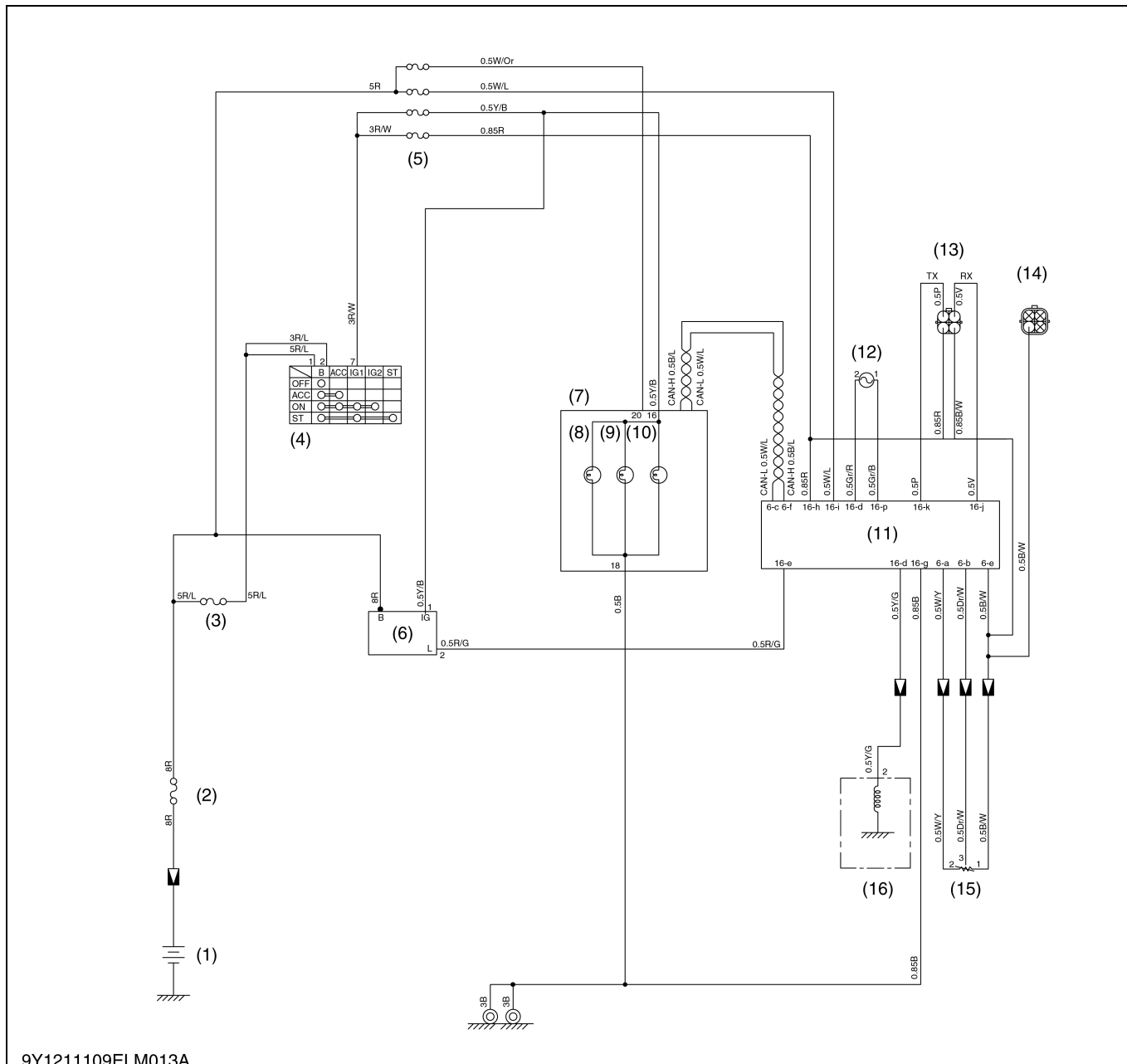

9Y1211109ELM013A

- | | | | |
|------------------------|----------------------|------------------------------|------------------------------|
| (1) Battery | (5) Fuse | (9) Mid PTO Lamp | (13) Cap |
| (2) Fuse (Main) | (6) Alternator | (10) Bi-speed Lamp | (14) Bi-speed Controller |
| (3) Fuse (Main Switch) | (7) Instrument Panel | (11) Travelling Speed Sensor | (15) Turning Angle Sensor |
| (4) Main Switch | (8) Rear PTO Lamp | (12) Checking Connector | (16) Bi-speed Solenoid Valve |

The bi-speed turn system is composed of traveling speed sensor, front wheel turning angle sensor, bi-speed valve. Those are controlled by bi-speed controller.

This system equipped with fail safe system. If the electrical sensor (Bi-speed valve, front wheel turning angle sensor or traveling speed sensor) has failed, the bi-speed indicator lamp, rear PTO indicator lamp or mid PTO indicator that located on the instrument panel will flash on to mention the system failure. (Refer to 9-S17, 9-S18.)

■ **NOTE**

- Bi-speed turn system is also explained in 3. TRANSMISSION, refer to 3-M13.

9Y1211109ELM0016US0

[2] SYSTEM OUTLINE

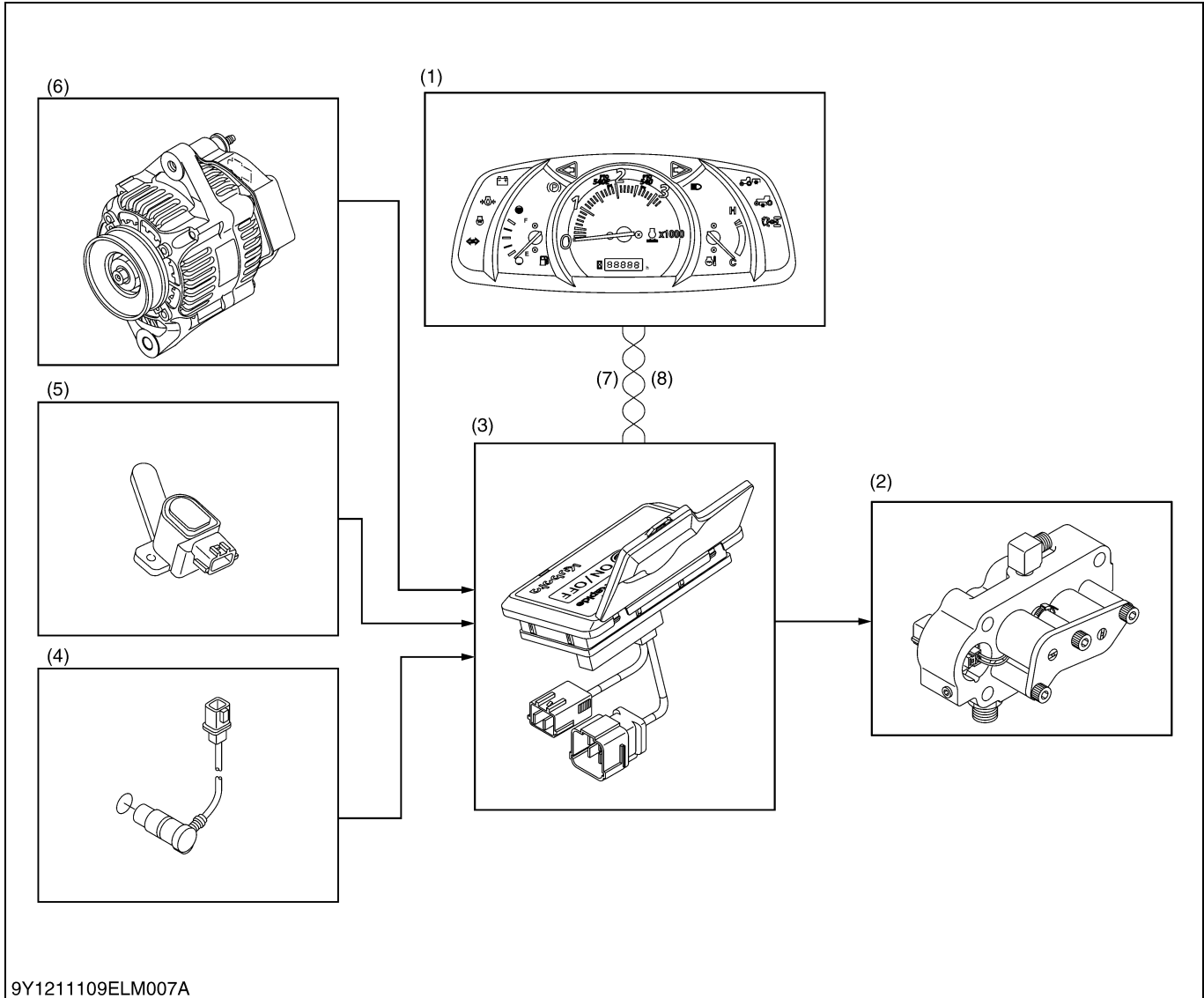

9Y1211109ELM007A

- | | | | |
|-----------------------------|-----------------------------|------------------------------|-----------|
| (1) Instrument Panel | (3) Bi-speed Controller | (5) Front Wheel Angle Sensor | (7) CAN-L |
| (2) Bi-speed Solenoid Valve | (4) Travelling Speed Sensor | (6) Alternator | (8) CAN-H |

(General Information for Bi-speed Controller)

- Bi-speed controller (ECU) processes and judges the input signals from the switches and sensors, and sends the signals to Bi -speed solenoid valves concerned with the bi-speed control system.
- Therefore, Bi-speed controller (ECU) controls the engagement of the hydraulic clutches.
- Instrument panel ECU processes and judges the input signals from the switches and sensors, and sends the signals to the indicators (Rear PTO indicator, Mid-PTO indicator and Bi-speed indicator) and the display error code
- All ECU shares information from switches and sensors.
- In the same way, Bi-speed controller (ECU) receives the input signals from switches and sensors. It converts them to instrument panel ECU with CAN.

(CAN: Controller Area Network)

CAN is the abbreviation for Controller Area Network. CAN forms the area network connected with all ECU. All information from sensors and switches are shared with all ECU by using CAN.

9Y1211109ELM0017US0

[3] BI-SPEED TURN SYSTEM

(1) Feature

It is used hydraulic and electrical control type bi-speed turn system.

The front wheel rotates by 1.5 times the speed compared with normal 4WD when the following conditions become complete.

Condition:

- Engine running
- 4WD mode
- Turned on the bi-speed switch
- Front wheel is steered to 0.61 rad (35 °) or more.
- The travelling speed within 0.2 to 9.0 km/h (0.13 to 5.62 mph)

9Y1211109ELM0023US0

(2) Related Parts and Arrangement

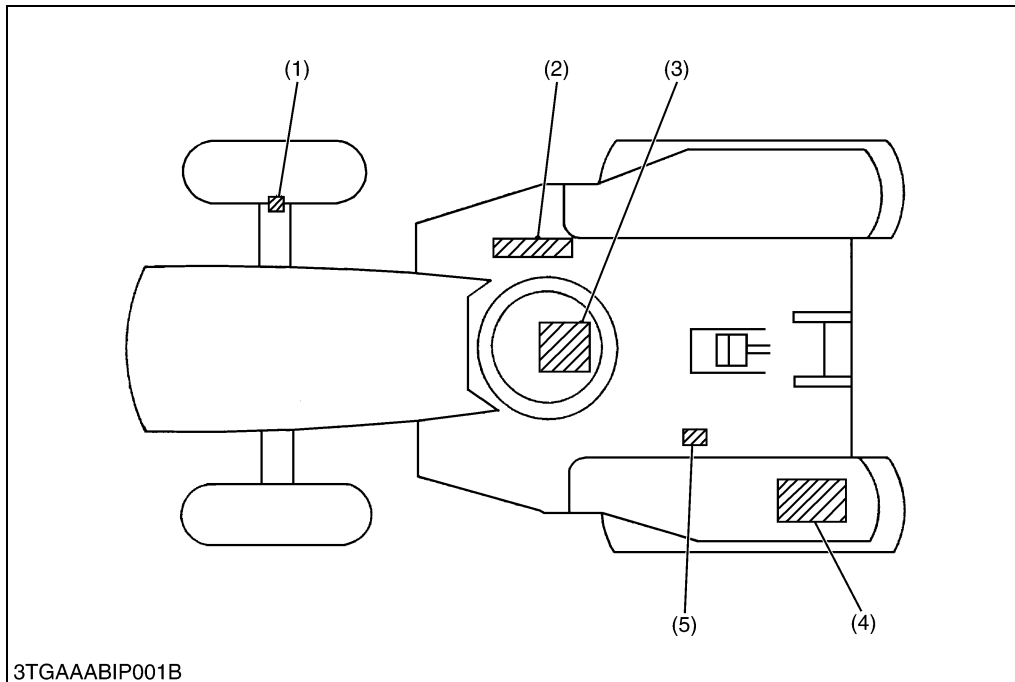

- (1) Front Wheel Turning Angle Sensor
- (2) Bi-speed Valve
- (3) Hydraulic Clutch (Bi-speed)
- (4) Bi-speed Controller
- (5) Travelling Speed Sensor

9Y1211109ELM0024US0

3TGAAABIP001B



9Y1211109TRM007A

Bi-speed Controller

This controller operates the bi-speed valve under specified condition based on the information from the front wheel turning angle sensor and travelling speed sensor. The bi-speed switch (1) is on the controller. The checking and adjusting of the bi-speed turn system can be done by handling this controller.

- (1) Bi-speed Switch
- (2) Bi-speed Controller

9Y1211109ELM0025US0

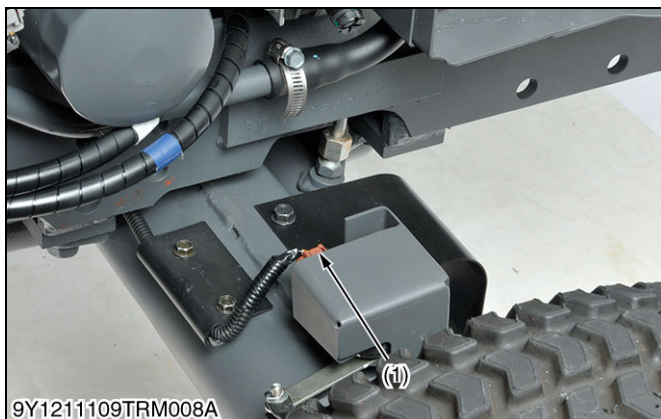

Front Wheel Turning Angle Sensor

This sensor perceives the steered angle of the front wheel.

- (1) Front Wheel Turning Angle Sensor

9Y1211109ELM0026US0

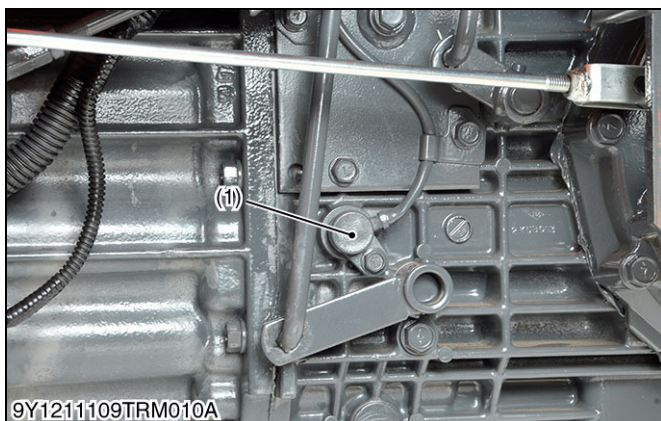

Travelling Speed Sensor

This sensor perceives the traveling speed.

- (1) Traveling Speed Sensor

9Y1211109ELM0027US0

6. INSTRUMENT PANEL

[1] SYSTEM OUTLINE

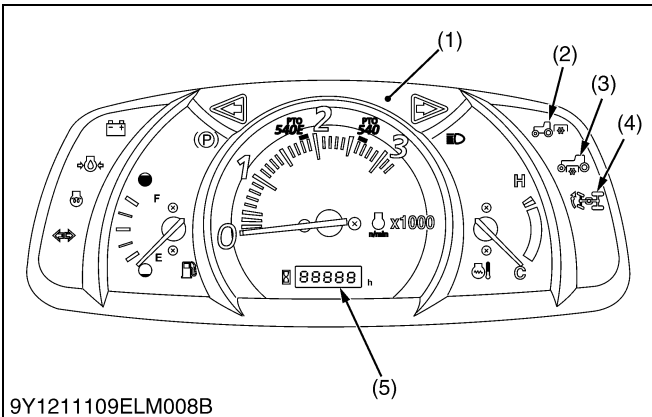

Instrument panel (ECU) and Bi-speed controller (ECU) use CAN (Controller Area Network) communication to share information from various sensors and switches.

The indicators of the rear PTO (2), mid PTO (3) and Bi-speed (4) on the instrument panel (1) are controlled by CAN.

If the tractor has a problem,

1. The indicators of rear PTO (2) or mid PTO (3) or Bi-speed (4) blinks.
2. The error code displays on LCD (5).

- (1) Instrument Panel
- (2) Rear PTO Indicator
- (3) Mid PTO Indicator
- (4) Bi-speed Indicator
- (5) LCD

9Y1211109ELM0028US0

[2] LCD MONITOR INDICATOR

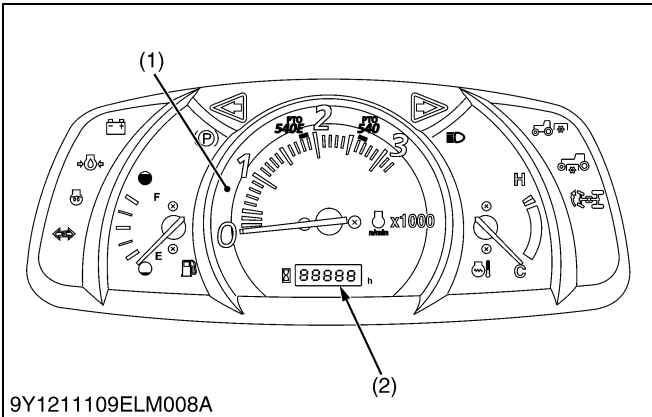

Hourmeter

- The hourmeter indicates in five digits the hours. The tractor has been used the last digit indicates 1/10 of an hour.

- (1) Instrument Panel
- (2) LCD Monitor

9Y1211109ELM0019US0

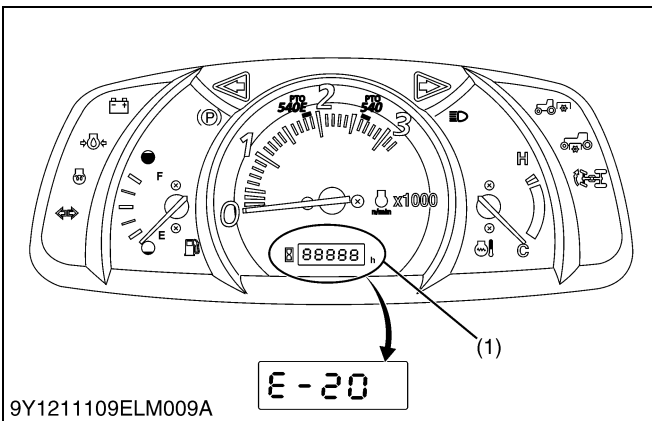

Error Code

1. If something is wrong with the CAN communication, the error code is displayed on the LCD (1).

Displayed error code	Trouble
E-20	CAN communication trouble between instrument panel and Bi-speed controller.

- (1) LCD

9Y1211109ELM0020US0

SERVICING

CONTENTS

1. TROUBLESHOOTING.....	9-S1
2. SERVICING SPECIFICATIONS.....	9-S9
3. TIGHTENING TORQUES.....	9-S10
4. CHECKING, DISASSEMBLING AND SERVICING.....	9-S11
[1] CHECKING AND ADJUSTING.....	9-S11
(1) Battery.....	9-S11
(2) Main Switch (ROPS Model).....	9-S12
(3) Main Switch (CABIN Model).....	9-S14
(4) Fail Safe System (Bi-speed Turn System).....	9-S15
(5) Fine Adjustment (Bi-speed Turn System).....	9-S16
(6) Self Diagnosis (Bi-speed Turn System).....	9-S17
(7) Bi-speed Restraint Check (Bi-speed Turn System).....	9-S18
(8) Checking by Bi-speed Controller (Main ECU).....	9-S19
(9) Checking by Instrument Panel.....	9-S23
(10)PTO Clutch Control Switch.....	9-S24
(11)Starter.....	9-S25
(12)Safety Switch.....	9-S26
(13)Relay.....	9-S27
(14)QGS Controller for CABIN.....	9-S29
(15)Coolant Temperature Sensor for CABIN.....	9-S30
(16)OPC Controller.....	9-S30
(17)Glow Plug.....	9-S30
(18)Key Stop Solenoid.....	9-S31
(19)Alternator.....	9-S32
(20)Combination Switch.....	9-S33
(21)Hazard Switch.....	9-S35
(22)Beacon Switch.....	9-S36
(23)Flasher Unit.....	9-S37
(24)Head Light.....	9-S37
(25)Brake Light Switch.....	9-S38
(26)Switches for Indicator Lamps (Rear PTO, Mid PTO, Parking Brake and Oil Pressure).....	9-S39
(27)Gauges.....	9-S40
(28)Trailer Socket.....	9-S41
[2] DISASSEMBLING AND ASSEMBLING.....	9-S42
(1) Starter.....	9-S42
(2) Alternator.....	9-S43
[3] SERVICING.....	9-S45
(1) Starter.....	9-S45
(2) Alternator.....	9-S47

1. TROUBLESHOOTING

Symptom	Probable Cause and Checking Procedure	Solution	Reference Page
All Electrical Equipment Do Not Operate	1. Battery is discharged or damaged.	Recharge or replace battery.	G-29
	2. Battery positive cable disconnected or improperly is connected.	Connect the battery positive cable properly.	9-S11
	3. Battery negative cable is disconnected or improperly connected.	Connect the battery negative cable properly.	9-S11
	4. Slow blow fuse is blown.	Replace slow blow fuse.	G-39
Fuse Blown Frequently	1. Wiring harness is short-circuited.	Repair or replace wiring harness.	–

BATTERY

Symptom	Probable Cause and Checking Procedure	Solution	Reference Page
Battery Discharges Too Quickly	1. Battery is damaged.	Recharge or replace battery.	G-29
	2. Alternator is damaged.	Repair or replace alternator.	9-S32, 9-S43
	3. Wiring harness is disconnected or improperly connected (between battery positive terminal and alternator B terminal).	Repair or replace wiring harness between battery positive terminal and alternator B terminal.	–
	4. Cooling fan belt is slipping.	Adjust fan belt tension or replace the fan belt immediately.	G-26

STARTING SYSTEM

Symptom	Probable Cause and Checking Procedure	Solution	Reference Page
Starter Motor Does Not Operate	1. Battery is discharged or damaged.	Recharge or replace battery.	G-29
	2. Slow blow fuse is blown.	Replace slow blow fuse.	G-39
	3. Safety switch is damaged.	Replace safety switch.	9-S26
	4. Safety switch is adjusted improperly.	Adjust safety switch.	9-S26
	5. Wiring harness is disconnected or improperly connected (between main switch ST terminal and safety switch between battery positive terminal and starter motor B terminal).	Repair or replace wiring harness between main switch ST terminal and safety switch between battery positive terminal and starter motor B terminal.	–
	6. Starter motor is damaged.	Repair or replace starter motor.	9-S25, 9-S42
	7. Main switch is damaged.	Replace main switch.	9-S12, 9-S14
Engine Does Not Start	1. Engine stop solenoid is damaged.	Replace engine stop solenoid.	9-S31
	2. Slow blow fuse is blown	Replace slow blow fuse.	–

AUTOMATIC ENGINE STOP SYSTEM

Symptom	Probable Cause and Checking Procedure	Solution	Reference Page
Engine Does Not Start	1. Seat switch is damaged.	Replace seat.	9-S26
	2. Key stop solenoid relay is damaged.	Replace key stop solenoid relay.	9-S29
	3. Key stop solenoid is damaged.	Replace key stop solenoid.	9-S31
	4. OPC controller is damaged.	Replace OPC controller.	9-S30
	5. Rear PTO switch is damaged.	Adjust or replace rear PTO switch.	9-S39
	6. Mid PTO switch is damaged.	Adjust or replace mid PTO switch.	9-S39
	7. Speed control pedal switch (HST) is damaged.	Adjust or replace speed control pedal switch (HST).	9-S26
Starter Motor Does Not Operate	1. Seat switch is damaged.	Replace seat.	9-S26
	2. Key stop solenoid relay is damaged.	Replace key stop solenoid relay.	9-S29
	3. Key stop solenoid is damaged.	Replace key stop solenoid.	9-S31
	4. Rear PTO switch is damaged.	Adjust or replace rear PTO switch.	9-S39
	5. Mid PTO switch is damaged.	Adjust or replace mid PTO switch.	9-S39
	6. Speed control pedal switch (HST) is damaged.	Adjust or replace speed control pedal switch (HST).	9-S26
	7. Clutch pedal safety switch is damaged.	Adjust or replace clutch pedal safety switch.	9-S26
	8. OPC controller is damaged.	Replace OPC controller.	9-S30

CHARGING SYSTEM

Symptom	Probable Cause and Checking Procedure	Solution	Reference Page
Charging Lamp Does Not Light When Main Switch is Turned ON	1. Fuse is blown.	Replace fuse.	G-38
	2. Wiring harness is disconnected or improperly connected (between main switch IG terminal and panel board, between panel board and alternator L terminal).	Repair or replace wiring harness between main switch IG terminal and panel board, between panel board and alternator L terminal.	–
Charging Lamp Does Not Go OFF When Engine is Running	1. Wiring harness between alternator L terminal lead and chassis is short-circuited.	Repair or replace wiring harness between alternator L terminal lead and chassis.	–
	2. Alternator is damaged.	Repair or replace alternator.	9-S32, 9-S42

LIGHTING SYSTEM

Symptom	Probable Cause and Checking Procedure	Solution	Reference Page
Head Light Does Not Light	1. Fuse is s blown.	Replace fuse.	G-38
	2. Bulb is blown.	Replace bulb.	G-39
	3. Head light relay is damaged.	Replace head light relay.	9-S27
	4. Wiring harness disconnected or improperly connected (between main switch IG terminal and combination switch B1 terminal, between combination switch 1 terminal and head light, between combination switch 2 terminal and head light)	Repair or replace wiring harness between main switch IG terminal and combination switch 1 terminal and head light, between combination switch 2 terminal and head light.	–
	5. Combination switch is damaged.	Replace combination switch.	9-S33
Turn Signal Light Does Not Light	1. Fuse is s blown.	Replace fuse.	G-38
	2. Bulb is blown.	Replace bulb.	G-39
	3. Flasher relay is damaged.	Replace flasher relay.	9-S27
	4. Wiring harness disconnected (between combination switch R terminal and flasher unit, between combination switch L terminal and flasher unit, between flasher unit and turn signal light)	Repair or replace wiring harness between combination switch R terminal and flasher unit, between combination switch L terminal and flasher unit, between flasher unit and turn signal light	–
	5. Flasher unit is damaged.	Replace flasher unit.	9-S27
	6. Combination switch is damaged.	Replace combination switch.	9-S33
Hazard Light Does Not Light	1. Fuse is s blown.	Replace fuse.	G-38
	2. Bulb is blown.	Replace bulb.	G-39
	3. Flasher relay is damaged.	Replace flasher relay.	9-S27
	4. Wiring harness disconnected or improperly connected	Repair or replace wiring harness.	–
	5. Flasher unit is damaged.	Replace flasher unit.	9-S37
	6. Hazard switch is damaged.	Replace hazard switch.	9-S35
Position Light Does Not Light (When Position Light Switch is pushed)	1. Fuse is s blown.	Replace fuse.	G-38
	2. Bulb is blown.	Replace bulb.	G-39
	3. Wiring harness disconnected. (between flasher unit and combination switch)	Repair or replace wiring harness between flasher unit and combination switch.	–
	4. Flasher unit is damaged.	Replace flasher unit.	9-S27

HORN

Symptom	Probable Cause and Checking Procedure	Solution	Reference Page
Horn Does Not Sound	1. Combination switch is damaged.	Replace combination switch.	9-S33
	2. Horn is damaged.	Replace horn.	–
	3. Head light relay is damaged.	Replace head light relay.	9-S27
	4. Wiring harness disconnected or improperly connected (between combination switch and horn)	Repair or replace wiring harness between combination switch and horn.	–

EASY CHECKER™

Symptom	Probable Cause and Checking Procedure	Solution	Reference Page
Engine Oil Pressure Lamp Lights Up When Engine is Running	1. Engine oil pressure is too low.	Repair engine oil pressure.	–
	2. Engine oil is insufficient.	Fill engine oil.	G-8
	3. Engine oil pressure switch is damaged.	Replace engine oil pressure switch.	9-S40
	4. Wiring harness between engine oil pressure switch lead and chassis is short-circuited.	Repair wiring harness between engine oil pressure switch lead and chassis.	–
	5. Electrical circuit in instrument panel board is damaged.	Replace instrument panel.	3-S17, 3-S32
Engine Oil Pressure Lamp Does Not Light When Main Switch is Turned ON and Engine is Not Running	1. Bulb is blown.	Replace instrument panel.	3-S17, 3-S32
	2. Engine oil pressure switch is damaged.	Replace engine oil pressure switch.	9-S40
	3. Wiring harness is disconnected or improperly connected (between instrument panel and engine oil pressure switch).	Repair or replace wiring harness between instrument panel and engine oil pressure switch.	–

GAUGES

Symptom	Probable Cause and Checking Procedure	Solution	Reference Page
Fuel Gauge Does Not Function	1. Fuel level sensor (tank unit) is damaged.	Replace fuel level sensor.	9-S40
	2. Wiring harness is disconnected or improperly connected (between instrument panel and fuel level sensor).	Repair or replace wiring harness between instrument panel and fuel level sensor.	–
Coolant Temperature Gauge Does Not Function	1. Coolant temperature sensor is damaged.	Replace coolant temperature sensor.	9-S40
	2. Wiring harness is disconnected or improperly connected (between instrument panel and coolant temperature sensor).	Repair or replace wiring harness between instrument panel and coolant temperature sensor.	–

FAIL SAFE SYSTEM

Blinking Indicator Lamp	Blinking Mode	Probable Cause and Checking Procedure	Solution	Reference Page
Bi-speed Turn	Slow (Light up: 1.0 sec./ light off: 0.2 sec.)	1. Front wheel angle sensor is damaged	See Self Diagnosis.	9-S17, 9-S18
		2. Wiring harness of traveling speed sensor is disconnected		
		1. Traveling speed sensor is damaged.		
		2. Wiring harness of front wheel angle sensor is disconnected.		
	Quick (Light up: 0.2 sec. / light of: 0.2 sec.)	1. Wiring of bi-speed turn solenoid is disconnected.	Check or replace wiring harness between bi-speed controller and bi-speed turn solenoid.	-
		2. Bi-speed turn solenoid is damaged.	Measure resistance between bi-speed turn solenoid and GND.	9-S21
Replace bi-speed turn valve.			8-S16	
Mid PTO and Rear PTO	Quick (Light up: 0.2 sec. / light off: 0.2 sec.)	1. Wiring of PTO solenoid is disconnected.	Check or replace wiring harness between bi-speed controller and PTO solenoid.	-
		2. PTO solenoid is damaged	Measure resistance between PTO solenoid and GND	-
			Replace bi-speed turn valve	8-S16
Bi-speed Turn, Mid PTO and Rear PTO	Quick (Light up: 0.2 sec. / light off: 0.2 sec.)	1. Wiring of bi-speed solenoid is disconnected.	Check or replace wiring harness between bi-speed controller and PTO solenoid	-
		2. Bi-speed turn solenoid is damaged	Measure resistance between bi-speed turn solenoid and GND	9-S21
			Replace bi-speed turn valve	8-S16
		1. Wiring of PTO solenoid is disconnected.	Check or replace wiring harness between bi-speed controller and PTO solenoid.	-
			2. PTO solenoid is damaged.	Measure resistance between PTO solenoid and GND
		Replace bi-speed turn valve.		8-S16

SELF DIAGNOSIS (INSTRUMENT PANEL)

Blinking Indicator Lamp	Blinking Time	Probable Cause and Checking Procedure	Solution	Reference Page
Bi-speed Turn	22	1. Signal line terminal 6-a of bi-speed controller from front wheel angle sensor voltage ≤ 0.2 or ≥ 4.9 V.	–	–
		2. Front wheel angle sensor is damaged.	Check or replace front wheel angle sensor.	9-S17, 9-S22
		3. Wiring harness is disconnected (between bi-speed controller and front wheel angle sensor).	Check or replace wiring harness between front wheel angle sensor and bi-speed controller.	9-S17, 9-S22
	18	1. Signal line terminal 16-P of bi-speed controller from traveling speed sensor voltage ≤ 2.19 V.	–	–
		2. Traveling speed sensor is damaged.	Check or replace traveling speed sensor.	9-S17, 9-S18, 9-S21
		3. Wiring harness is disconnected (between bi-speed controller and traveling speed sensor).	Check or replace wiring harness between traveling speed sensor and bi-speed controller.	9-S17, 9-S21

ERROR DISPLAY ON LCD (CAN COMMUNICATION ERROR)

Display on LCD	Probable Cause and Checking Procedure	Solution	Reference Page
E-20	1. Communication error between bi-speed controller (ECU) and Instrument panel (ECU). • CAN bus line is disconnected or short-circuited.	Check or replace the communication lines.	–
	2. No signal from bi-speed controller.	Measure the voltage of bi-speed controller connector and instrument panel connector.	9-S19, 9-S20, 9-S23
		Measure the input voltage at bi-speed controller connector.	9-S20
	3. Bi-speed controller (ECU) is damaged.	Replace bi-speed controller.	9-S20
	4. Instrument panel is damaged.	Replace instrument panel.	9-M19
5. Battery voltage below 7 V	Recharge or replace battery.	G-29	

9Y1211109ELS0001US0

2. SERVICING SPECIFICATIONS

Item		Factory Specification	Allowable Limit
Starter	• Commutator	O.D. 30.0 mm 1.181 in.	29.0 mm 1.142 in.
	• Mica	Under Cut 0.50 to 0.80 mm 0.0197 to 0.0315 in.	0.20 mm 0.0079 in.
	• Brush	Length 15.0 mm 0.591 in.	11.0 mm 0.433 in.
	• Brush Holder and Holder Support	Resistance Infinity	–
Glow Plug	Resistance	Approx. 0.9 Ω	–
Stop Solenoid	• Pull-in Coil	Resistance Approx. 0.375 Ω	–
	• Holding Coil	Resistance Approx. 15.6 Ω	–
Fuel Level Sensor	• Float at Upper-most Position	Resistance 1.0 to 5.0 Ω	–
	• Float at Lower-most Position	Resistance 103 to 117 Ω	–
Coolant Temperature Sensor	• at 120 °C (266 °F)	Resistance Approx. 16.1 Ω	–
	• at 100 °C (221 °F)	Resistance Approx. 27.4 Ω	–
	• at 80 °C (176 °F)	Resistance Approx. 51.9 Ω	–
	• at 50 °C (122 °F)	Resistance Approx. 153.9 Ω	–
Alternator	No-load voltage	More than 14 V	–
	• Stator	Resistance Less than 1.0 Ω	–
	• Rotor	Resistance 2.9 Ω	–
	• Slip Ring	O.D. 14.4 mm 0.567 in.	12.8 mm 0.504 in.
	• Brush	Length 10.5 mm 0.413 in.	8.4 mm 0.331 in.

9Y1211109ELS0002US0

3. TIGHTENING TORQUES

Tightening torques of screws, bolts and nuts on the table below are especially specified.
(For general use screws, bolts and nuts: Refer to "5. TIGHTENING TORQUES" on page G-10.)

Item	N·m	kgf·m	lbf·ft
Alternator (Pulley nut)	58.3 to 78.9	5.95 to 8.05	43.0 to 58.2

9Y1211109ELS0003US0

4. CHECKING, DISASSEMBLING AND SERVICING



CAUTION

- To avoid accidental short circuit, be sure to attach the positive cable to the positive terminal before the negative cable is attached to the negative terminal.
- Never remove the battery cap while the engine is running.
- Keep electrolyte away from eyes, hands and clothes. If you are spattered with it, wash it away completely with water immediately.
- Keep open sparks and flames away from the battery at all times. Hydrogen gas mixed with oxygen becomes very explosive.

IMPORTANT

- If the machine is to be operated for a short time without battery (using a slave battery for starting), use additional current (lights) while engine is running and insulate terminal of battery. If this advice is disregarded, damage to alternator and regulator may result.

9Y1211109ELS0004US0

[1] CHECKING AND ADJUSTING

(1) Battery

Battery Condition

- See page G-28 "Checking Battery Condition".

9Y1211109ELS0005US0

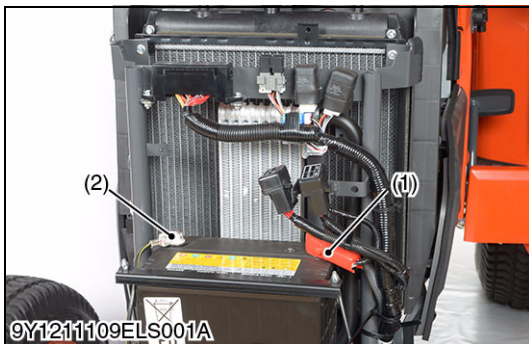

Battery Voltage

1. Stop the engine and turn the main switch off.
2. Connect the COM (-) lead of the voltmeter to the battery's negative terminal post and the (+) lead to the positive terminal post, and measure the battery voltage.
3. If the battery voltage is less than the factory specification, check the battery specific gravity and recharge the battery.

Battery voltage	Factory specification	More than 12 V
-----------------	-----------------------	----------------

(1) Battery Positive Cable

(2) Battery Negative Cable

9Y1211109ELS0006US0

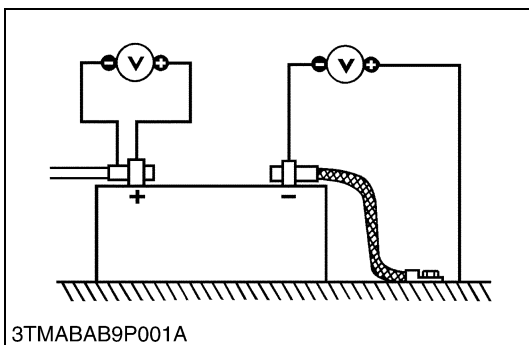

Battery Terminal Connection

1. Turn the main switch on, and turn on the head light.
2. Measure the voltage across the battery's positive terminal post and the cable terminal, the voltage across the battery's negative terminal post and the chassis.
3. If the measurement exceeds the factory specification, clean the battery terminal posts and cable clamps, and tighten them firmly.

Potential difference	Reference value	Less than 0.1 V
----------------------	-----------------	-----------------

WSM000001ELS0001US0

(2) Main Switch (ROPS Model)

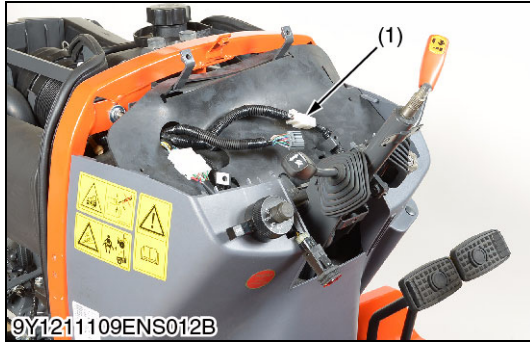

Main Switch

1. Remove the instrument panel.
2. Disconnect the **4P** connector (1) and remove the main switch.
3. Perform the following checks.

(1) **4P** Connector

9Y1211109ELS0007US0

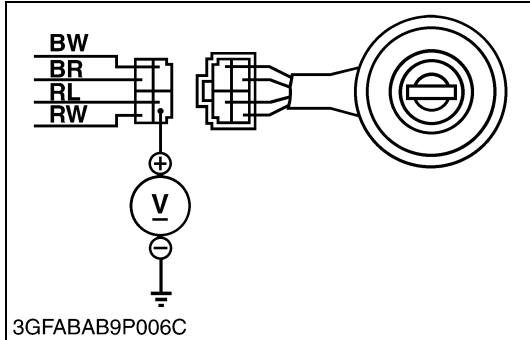

Connector Voltage

1. Measure the voltage with a voltmeter across the connector **B** terminal and chassis.
2. If the voltage differs from the battery voltage (11 to 14 V), the wiring harness is faulty.

Voltage	Connector B terminal – Chassis	Approx. battery voltage
---------	---------------------------------------	-------------------------

9Y1211109ELS0008US0

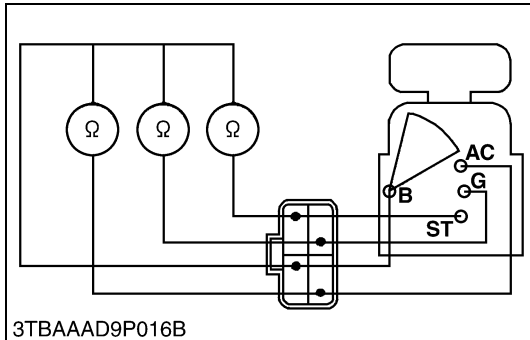

Main Switch Continuity

1) Main Switch Key at OFF Position

1. Set the main switch **OFF** position.
2. Measure the resistance with an ohmmeter across the **B** terminal and the **AC** terminal, **B** terminal and **ST** terminal, **B** terminal and **G** terminal.
3. If infinity is not indicated, the contacts of the main switch are faulty.

Resistance	B terminal – AC terminal	Infinity
	B terminal – ST terminal	
	B terminal – G terminal	

9Y1211109ELS0009US0

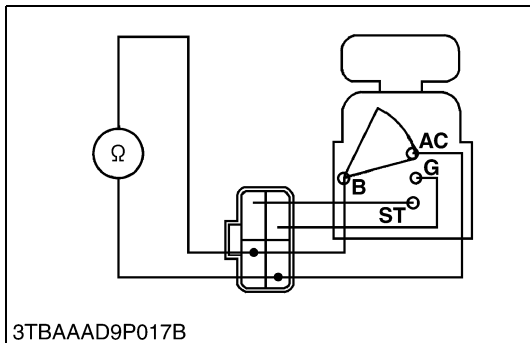

2) Main Switch Key at ON Position

1. Set the main switch **ON** position.
2. Measure the resistance with an ohmmeter across the **B** terminal and the **AC** terminal.
3. If 0 ohm is not indicated, the **B - AC** contact of the main switch are faulty.

Resistance	B terminal – AC terminal	0 Ω
------------	--	-----

9Y1211109ELS0010US0

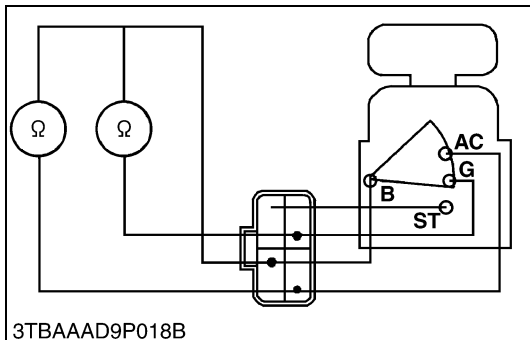

3) Main Switch Key at PREHEAT Position

1. Set and hold the main switch key at the **PREHEAT** position.
2. Measure the resistance with an ohmmeter across the **B** terminal and the **G** terminal, and measure the resistance across the **B** terminal and the **AC** terminal.
3. If 0 ohm is not indicated, these contacts of the main switch are faulty.

Resistance	B terminal – G terminal	0 Ω
	B terminal – AC terminal	

9Y1211109ELS0011US0

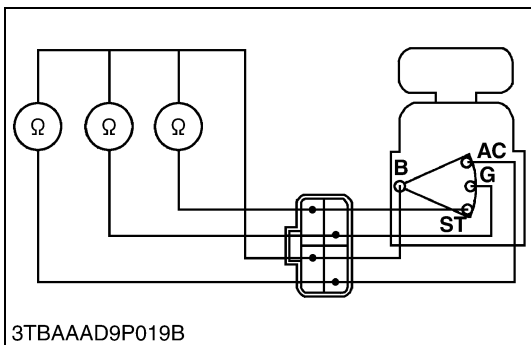

4) Main Switch Key at START Position

1. Set and hold the main switch key at the **START** position.
2. Measure the resistance with an ohmmeter across the **B** terminal and the **G** terminal, across the **B** terminal and the **ST** terminal, and across the **B** terminal and the **AC** terminal.
3. If 0 ohm is not indicated, these contacts of the main switch are faulty.

Resistance	B terminal – G terminal	0 Ω
	B terminal – ST terminal	
	B terminal – AC terminal	

Key position	Terminal			
	B	AC	G	ST
OFF	●			
ON	●	●		
PREHEAT	●	●	●	
START	●	●	●	●

9Y0211304ELS001US

9Y1211109ELS0012US0

(3) Main Switch (CABIN Model)

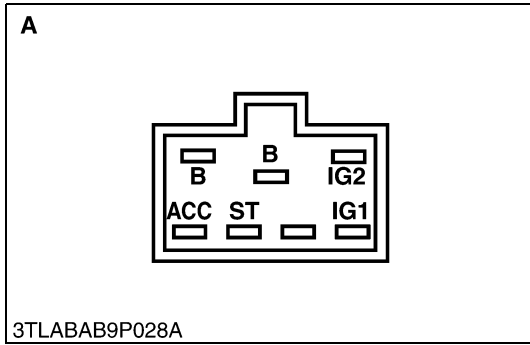

Connector Voltage

1. Measure the voltage across the connector **B** terminal and chassis.
2. If the voltage differs from the battery voltage (11 to 14 V), the wiring harness is faulty.

Voltage	Connector B terminal – Chassis	Approx. battery voltage
---------	---------------------------------------	-------------------------

A: Wire Harness Side Connector 6G

9Y1211109ELS0013US0

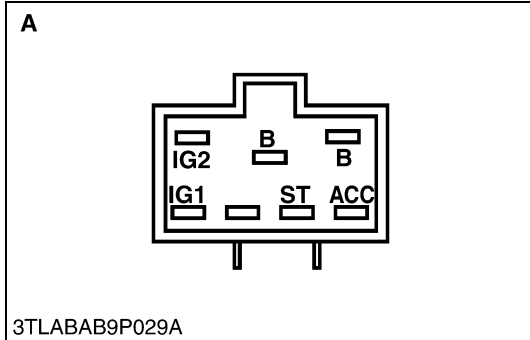

Main Switch at ACC Position

1. Turn the main switch **ACC** position.
2. Measure the resistance across the **B** terminal and the **ACC** terminal.
3. If 0 ohm is not indicated, renew the main switch.

Resistance	B terminal – ACC terminal	0 Ω
------------	---	-----

A: Main Switch Side Connector 6G

9Y1211109ELS0014US0

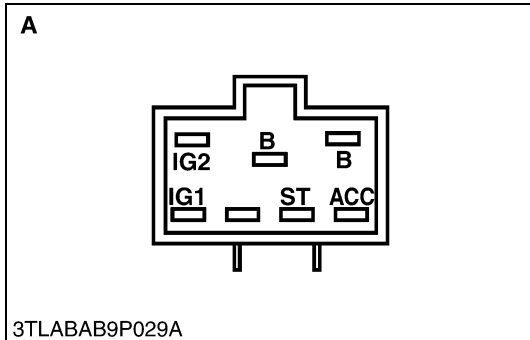

Main Switch at Key ON Position

1. Turn and hold the main switch at the "**ON**" position.
2. Measure the resistances across the **B** terminal and the **ACC** terminal, across **B** terminal and **IG1** terminal and **B** terminal and **IG2** terminal.
3. If 0 ohm is not indicated, renew the main switch.

Resistance	B terminal – ACC terminal	0 Ω
	B terminal – IG1 terminal	0 Ω
	B terminal – IG2 terminal	0 Ω

A: Main Switch Side Connector 6G

9Y1211109ELS0015US0

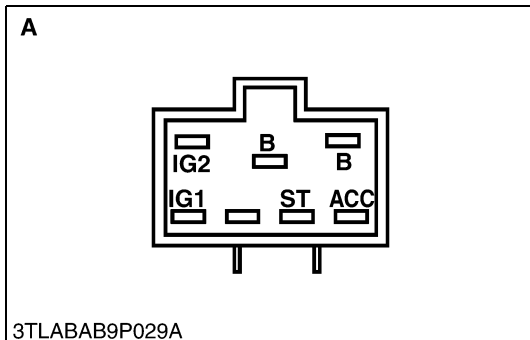

Main Switch at START Position

1. Turn and hold the main switch at the "**START**" position.
2. Measure the resistances across the **B** terminal and the **IG1** terminal, and across the **B** terminal, and the **ST** terminal.
3. If 0 ohm is not indicated, renew the main switch.

Resistance	B terminal – IG1 terminal	0 Ω
	B terminal – ST terminal	0 Ω

A: Main Switch Side Connector 6G

9Y1211109ELS0016US0

(4) Fail Safe System (Bi-speed Turn System)



The fail safe system mentions to the operator for some trouble occurred while operating the tractor.

When the fail safe system is operated, the bi-speed turn indicator lamp (1), rear PTO indicator lamp and mid PTO indicator lamp blinks and informs troubled parts. And the bi-speed turn system does not work.

Blinking Indicator Lamp	Blinking Mode	Troubled Parts
Bi-speed Turn	Slow (Light up: 1.0 sec. / lights off: 0.2 sec.)	• Front wheel angle sensor
		• Traveling speed sensor
Bi-speed Turn	Quick (Light up: 0.2 sec. / lights off: 0.2 sec.)	• Bi-speed turn solenoid valve • Wiring of Bi-speed turn solenoid is disconnected.
Rear PTO and Mid PTO	Quick (Light up: 0.2 sec. / lights off: 0.2 sec.)	• PTO Solenoid • Wiring of PTO solenoid is disconnected.
Bi-speed Turn, Rear and Mid PTO	Quick (Light up: 0.2 sec. / lights off: 0.2 sec.)	• Bi-speed turn solenoid and PTO solenoid • Wiring of Bi-speed turn solenoid and PTO solenoid are disconnected.

- (1) Bi-speed Turn Indicator
- (2) Mid-PTO Indicator

- (3) Rear PTO Indicator

9Y1211109ELS0019US0

(5) Fine Adjustment (Bi-speed Turn System)

When the front wheel turning angle sensor is replaced, the fine adjustment should be done to set the wheel angle information for the bi-speed controller.

Procedure 1: Making standard setting for the fine adjustment

1. Get the front wheels in the straight-run state.
2. Turn off the main switch.

Procedure 2: Changing to the fine adjustment mode

1. Hold down the bi-speed switch and turn on the main switch (The engine does not start). Now make sure the bi-speed indicator lamp lights up and goes out 0.75 second later.
2. Release the bi-speed switch. This calls for the "fine adjustment and self-diagnosis mode".

Procedure 3: Checking the bi-speed indicator lamp light-up and saving the fine adjustment data

1. First check up the bi-speed indicator lamp.
If any setting is wrong or a component part is defective or malpositioned, the bi-speed indicator lamp starts blinking the number of times that corresponds to a trouble spot. See the [Lamp Blinking Chart] in "(6) Self Diagnosis". The bi-speed lamp indicator remains off when there is nothing in trouble. If it is necessary to start the engine for making the settings again, turn off the main switch and repeat from the above steps 1 in Procedure 1.
2. When the data is judged correct, the bi-speed indicator lamp lights up and stays on. Then hold down the bi-speed switch for longer than 3 seconds. (The bi-speed indicator lamp goes out just when this switch is pressed down.).
3. When the fine adjustment data has been properly saved, the bi-speed indicator lamp lights up and stays on again. Now release the bi-speed switch.
4. If the data has not been saved properly, the bi-speed indicator lamp starts flashing at shorter intervals. In such case, turn off the main switch and repeat the steps from Step 1 in procedure 2.

Procedure 4: Exiting from the fine adjustment mode

1. Make sure the bi-speed indicator lamp stay on. Finally turn off the switch.

(Reference)

■ Standard Setting for Fine Adjustment and Self Diagnosis

Description	Status	Related Sensor
Front wheel	Straight run	Front wheel turning angle sensor
Tractor body	Stop	Travelling speed sensor
Engine	Stop	—

9Y1211109ELS0022US0

(6) Self Diagnosis (Bi-speed Turn System)

The self-diagnosis mode is to make easier for find out the trouble point when bi-speed system has been broken down. The handling method of there systems are as follow.

Procedure 1: Making standard setting for the self-diagnosis

1. Get the front wheels in the straight-run state.
2. Turn off the main switch.

Procedure 2: Changing to the self-diagnosis mode

1. Hold down the bi-speed switch and turn on the main switch (The engine does not start). Now make sure the bi-speed lamp lights up and goes out 0.75 second later.
2. Release the bi-speed switch. This call for the "Fine adjustment and self-diagnosis mode".

Procedure 3: Checking the lamp bi-speed indicator light-up and operating the self-diagnosis

1. First check up the bi-speed indicator lamp. If any setting is wrong or a component part is defective or malpositioned, the lamp starts blinking the number of times that corresponds to a trouble spot. See the "Lamp Blinking Chart" below. If it is necessary to start the engine for making the settings again, turn off the main switch and repeat the above step from step 1 in procedure 1.
2. When the judgement is correct, the bi-speed indicator lamp lights up and stays on.

Procedure 4: Exiting from the self-diagnosis mode

1. Turn off the main switch.

[Lamp Blinking Chart]

Number of blinking (times)	Defective Sensor
22	Front wheel turning angle sensor
18	Travelling speed sensor

■ NOTE

- The bi-speed indicator lamp flashes at the following intervals: 1.1-second on for the tens digit, 0.4-second on for the units digit and 0.4-second off between two on's.
- A 1.5-second off interval is put between two different pieces of date.

9Y1211109ELS0023US0

(7) Bi-speed Restraint Check (Bi-speed Turn System)

The bi-speed restraint function is designed to deactivate the bi-speed control when the machine is at a halt or running at low speed (below 0.2 km/h) or high speed (above 9.0 km/h).

The following procedures are to check the travelling speed sensor output and the controller's bi-speed restraint function.

Procedure 1: Changing to the bi-speed restraint check mode

1. Hold down the bi-speed switch and turn on the main switch (The engine does not start). Now make sure the bi-speed indicator lamp lights up and goes out 0.75 second later.
2. Release the bi-speed switch. This calls for the "Fine adjustment and self-diagnosis mode".
3. With the machine in the above mode, start the engine. The controller monitors the potential at the alternator terminal **L** and calls for the "Bi-speed restraint check mode" when the engine is detected to get started. (In this mode, the bi-speed control does not work. The bi-speed restraint, depending on the input from the travelling speed sensor but regardless of the front wheel turning angle sensor output, is shown with the bi-speed lamp.)

Procedure 2: Checking the travelling speed sensor input

1. Drive the tractor straight in each of the following 3 conditions and look at the bi-speed indicating lamp to see if the bi-speed restraint works accordingly. The travelling speed sensor is mounted on the 22T gear of differential gear case.

(Reference)

	Approximate travelling speed with standard tire	Bi-speed indicator lamp
A	0 to 0.2 km/h (0 to 0.13 mph)	Turned off
B	0.2 to 9.0 km/h (0.13 to 5.62 mph)	Lights up
C	over 9.0 km/h (over 5.62 mph)	Turned off

- Checking condition **A**: Tractor at stop
- Checking condition **B**: Drive the tractor with range gear shift 1, cruise control lever at 2 notches at engine speed around 1000 min⁻¹ (rpm)
- Checking condition **C**: Drive the tractor with range gear shift 2, depress the HST foot pedal fully for forward at engine speed around 2000 min⁻¹ (rpm)

Procedure 3: Checking the bi-speed control output

1. Switch off the main switch.
2. Switch on the main switch again to start the engine. Enter the ordinary control mode.
3. Turn on the bi-speed mode and turn the tractor right and left to make sure the bi-speed control functions.
4. Turn off the bi-speed mode and turn the tractor right and left to make sure the bi-speed control does not function.

Procedure 4: Exiting from the bi-speed restraint check mode

1. Turn off the main switch.
2. The bi-speed restraint mode can be accepted through the above two procedures "Checking the travelling speed sensor input" and "Checking the bi-speed control output".

9Y1211109ELS0024US0

(8) Checking by Bi-speed Controller (Main ECU)

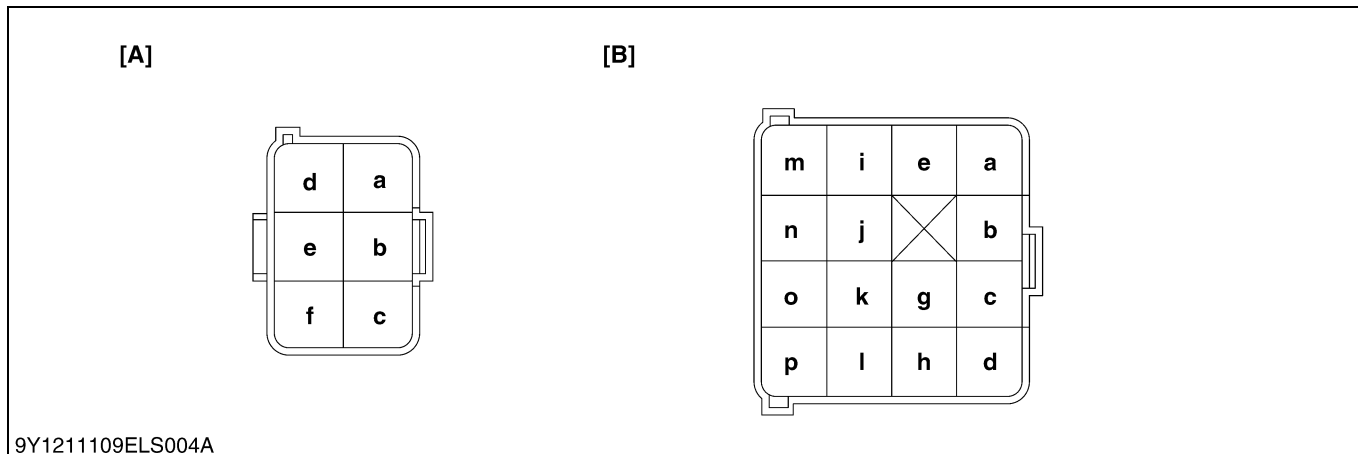

9Y1211109ELS004A

Connector [A] (6P Connector) of Wire Harness Side

No.	Color of wiring	Terminal Name [A]
a	Gr/R	+5 V (Power Source for Front Wheel Angle Sensor)
b	Or/W	Front Wheel Angle Sensor (Signal)
c	W/L	CAN (L)
d	Gr/R	+5 V (Power Source for Traveling Speed Sensor)
e	B/W	Front Wheel Angle Sensor (GND)
f	B/L	CAN (H)

Connector [B] (16P Connector) of Wire Harness Side

No.	Color of wiring	Terminal Name
a	V/W	OPC Controller
b	Br/Y	OPC Controller
c	R/W	PTO Solenoid Valve
d	Y/G	Bi-speed Solenoid Valve
e	R/G	Alternator (L Terminal)
f	-	-
g	B	Bi-speed Controller (GND)
h	R	+12 V (IG1)
i	W/L	+12 V (Battery)
j	V	Check Connector
k	P	Check Connector
l	G/Y	Speed Control Pedal Switch
m	R/V	I-PTO Switch
n	P/L	Mid PTO Switch
o	L/R	Rear PTO Switch
p	Gr/B	Traveling Speed Sensor (Signal)

9Y1211109ELS0020US0

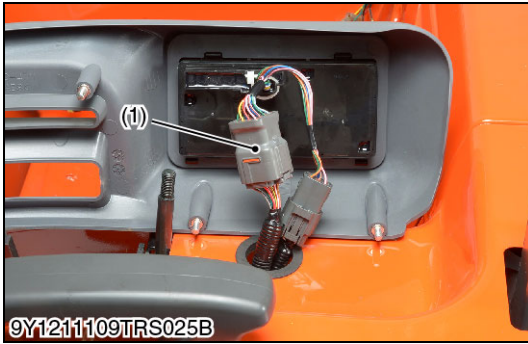

Bi-speed Controller Connector Voltage

1) Connector Voltage

1. Disconnect the **16P** connector (1).
2. Turn the main switch to ON position. It is not necessary to run the engine.
3. Measure the voltage with voltmeter across the **h** terminal (4) and **g** terminal (3). If the voltage differs from the battery voltage, check the fuse, wiring harness or ground condition.

Voltage	h Terminal and g Terminal	Battery voltage (11 to 14 V)
---------	---	---------------------------------

- (1) Connector
 (2) Connector (Harness Side)
 (3) **h** Terminal
 (4) **g** Terminal

9Y1211109ELS0017US0

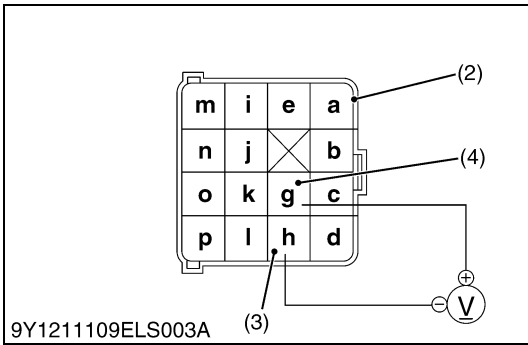

2) Output Voltage

1. Remove the connector for bi-speed valve.
2. Jack up the rear wheels and shift the front wheel drive lever to **OFF** position.
3. Start the engine and turn the rear wheels as following condition.
 - Range shift lever: 1
 - Cruise control lever: 2 notches
 - Engine speed: around 1000 min⁻¹ (rpm)
4. Steer the front wheel to the left or the right 0.61 rad (35 °) or more.
5. Measure the voltage across the following terminals and chassis. If the voltage differs from the factory specifications, check the wire harness.

CAUTION

- **Be sure to disengage the front wheel drive, when checking the voltages with rotate the rear wheel.**

Voltage between Terminal (2) and chassis	Front wheel is steered to the right or the left 0.61 rad (35 °) or more	Battery Voltage
	Front wheel is straight	0 V

- (1) Bi-speed Valve Connector
 (2) Terminal (Y/G)

9Y1211109ELS0018US0

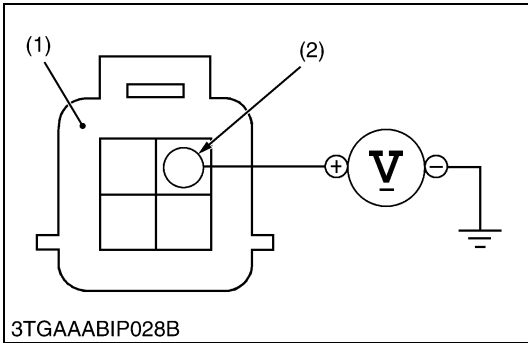
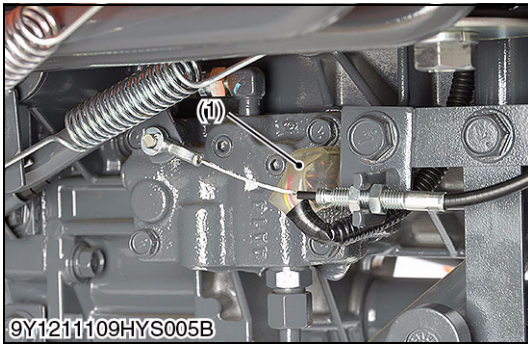

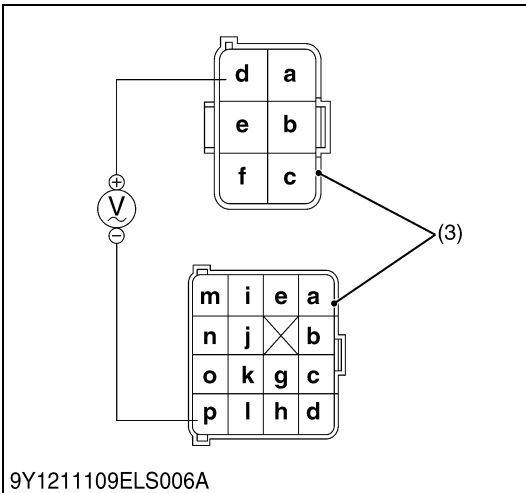
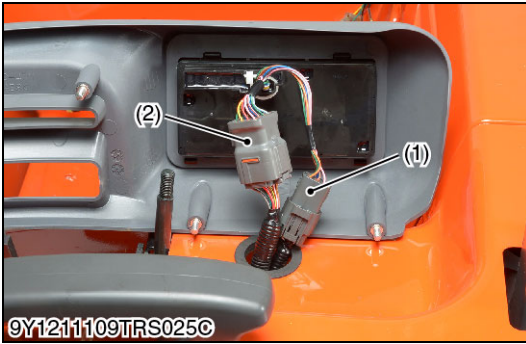

Travelling Speed Sensor

1. Disconnect the connectors (1), (2).
2. Jack up the rear wheels and shift the front wheel drive lever to **OFF** position.
3. Start the engine and turn the rear wheel as following condition.
 - Range shift lever: 1
 - Cruise control lever: 2 notch
 - Engine speed: around 1000 min⁻¹ (rpm)
4. Measure the travelling speed sensor voltage on the connector's terminal of wire harness side **6P** connector of **d** terminal - **16P** terminal of **p** terminal.

CAUTION

- Be sure to disengage the front wheel drive, when checking the travelling speed sensor with rotating the rear wheel.

NOTE

- The analog type tester may not check for voltage.
- There is no need to "Fine adjustment" about travelling speed sensor if replaced.
- Be sure to check the alternate voltage range.

Output alternate voltage of travelling speed sensor	Factory specification	d terminal – p terminal	Approx. AC 1.0 V
---	-----------------------	-------------------------	------------------

- (1) **6P** Connector
 (2) **16P** Connector

(3) Connector (Wire Harness)

9Y1211109ELS0025US0

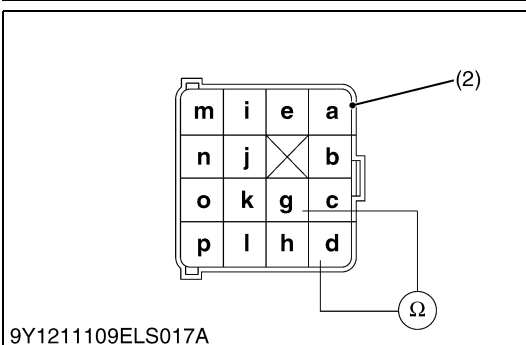
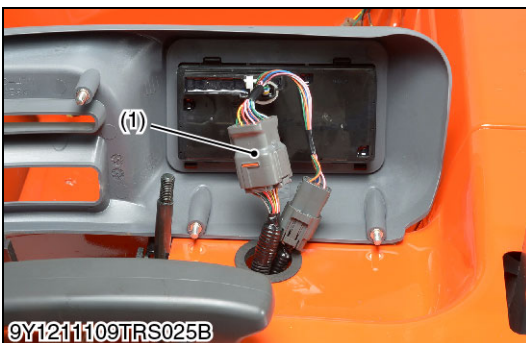

Bi-speed Solenoid Valve

[Solenoid]

1. Disconnect the **16P** connector (1).
2. Measure the bi-speed solenoid valve resistance between **g** terminal (Ground) and **d** terminal (solenoid valve).
 If the measurement is not within the factory specifications, replace it.

Resistance between bi-speed solenoid valve and ground	Factory specification	g terminal – d terminal	11 to 15 Ω
---	-----------------------	-------------------------	------------

- (1) Connector

(2) Connector (Wire Harness)

9Y1211109ELS0026US0

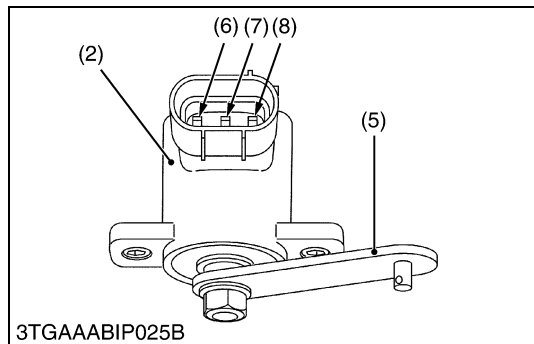
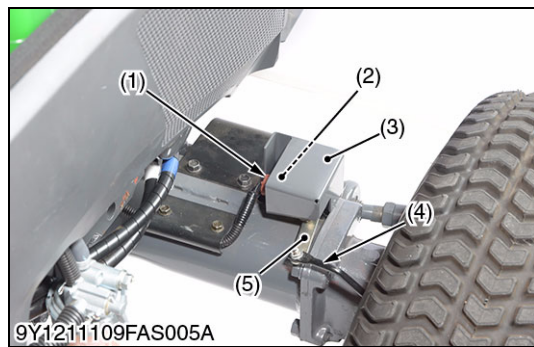

Front Wheel Turning Angle Sensor

1. Separate the arm (4) from angle sensor lever (5).
2. Disconnect the connector (1).
3. Remove the sensor with sensor cover (3), then remove the sensor from sensor cover (3).
4. Measure the angle sensor resistance between the **A** terminal (6) and ground **C** terminal (8).
5. Set the test lead of tester between **B** terminal (7) and ground **C** terminal (8).
Turn the sensor lever (5) slowly and check the changing of resistance value.
6. If measurement is not within the factory specifications, replace it.

■ **IMPORTANT**

- **If replaced a front wheel turning angle sensor, be sure to operate the "Fine adjustment system".**

Front wheel turning angle sensor resistance	Factory specification	A terminal – C terminal	4.32 to 6.48 kΩ
Changing of resistance value	Factory specification	B terminal – C terminal	Changing with smoothly

- | | |
|--------------------------------------|--------------------------------|
| (1) Connector | (5) Lever |
| (2) Front Wheel Turning Angle Sensor | (6) A Terminal |
| (3) Sensor Cover | (7) B Terminal |
| (4) Arm | (8) C Terminal (Ground) |

9Y1211109ELS0027US0

(9) Checking by Instrument Panel

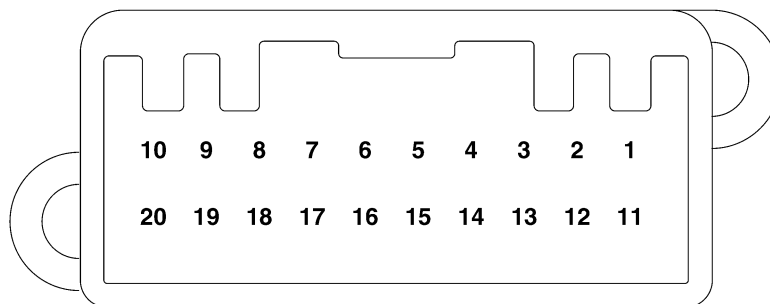

9Y1211109ELS005A

Connector of Wire Harness Side

No.	Color of wiring	Terminal Name
1	-	-
2	G/B	Trailer Coupler
3	B/R	Glow (ROPS)
4	Sb	Glow (Cabin)
5	L/W	Engine Oil Switch
6	R/G	Alternator L Terminal
7	R/L	Parking Brake Switch
8	Sb	Turn L
9	G	Turn R
10	Br	High Beam
11	W/L	CAN L
12	B/L	CAN H
13	-	-
14	-	-
15	P/G	Tachometer
16	Y/B	+12 V (IG1)
17	T/G	Fuel Sensor
18	B	GND
19	W/Y	Coolant Temperature Sensor
20	W/Or	+12 V (Battery)

9Y1211109ELS0021US0

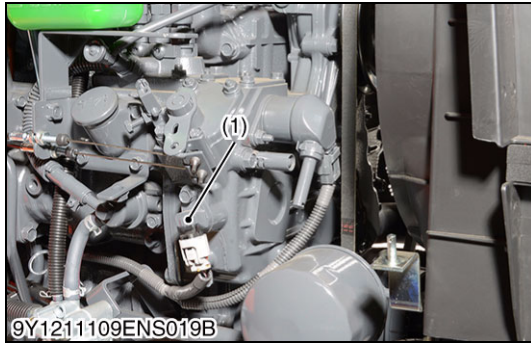

Engine Tachometer Sensor

1. Measure the resistance between terminal of panel and terminal of sensor connector.
2. If 0 ohm is not indicated, the wiring harness is faulty.

Resistance	Terminal 15 of panel connector – Terminal 2 of sensor connector	0 Ω
------------	---	-----

- (1) Engine Tachometer Sensor **A: Connector of Wire Harness Side**
 (2) Terminal 1 **B: Panel Connector of Wire Harness**
 (3) Terminal 2
 (4) Terminal 3
 (5) Terminal 15

9Y1211109ELS0078US0

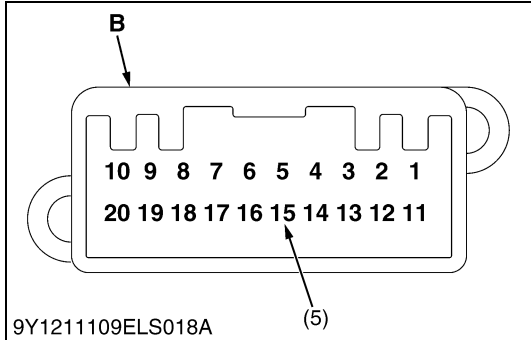
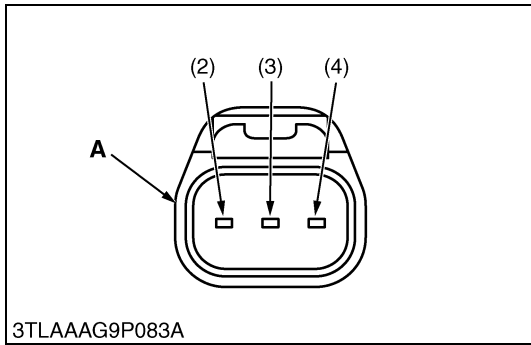

(10) PTO Clutch Control Switch

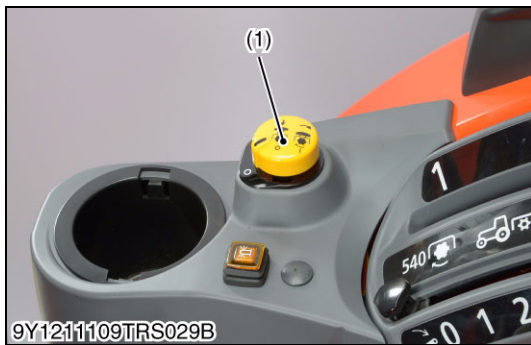

PTO Clutch Control Switch

1) Connector Voltage

1. Remove the PTO switch connector (2).
2. Turn the main switch "ON" position.
3. Measure the voltage across terminal 2 (Harness) and chassis.
4. If the voltage differs from battery voltage, the wiring harness, fuse, or main switch is faulty.

Voltage	Terminal 2 – Chassis	Approx. battery voltage
---------	----------------------	-------------------------

2) PTO Switch Continuity

1. Remove the PTO switch connector (1).
2. Check the continuity with an ohmmeter across the terminal 1 (a) and terminal 2 (b), terminal 2 (b) and terminal 3 (c).
3. If connection does not change, PTO switch is faulty.

Position	Terminal 1 – terminal 2	Terminal 2 – terminal 3
OFF	0 Ω	Infinity
ON	Infinity	0 Ω

- (1) PTO Switch **(a) Terminal 1**
 (2) PTO Switch Connector **(b) Terminal 2**
 (c) Terminal 3

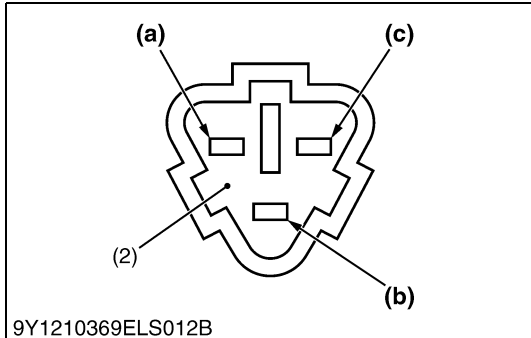

9Y1211109ELS0028US0

(11) Starter

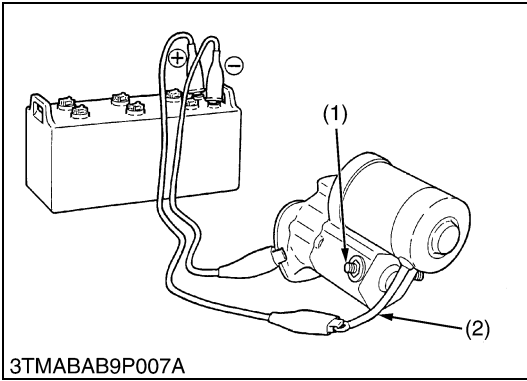

Motor Test



CAUTION

- **Secure the starter to prevent it from jumping up and down while testing the motor.**
1. Disconnect the battery negative cable from the battery.
 2. Disconnect the battery positive cable and the leads from the starter.
 3. Remove the starter from the engine.
 4. Disconnect the connecting lead (2) from the starter **C** terminal (1).
 5. Connect a jumper lead from the connecting lead (2) to the battery positive terminal post.
 6. Connect a jumper lead momentarily between the starter motor housing and the battery negative terminal post.
 7. If the motor does not operate, check the motor.

(1) **C** Terminal

(2) Connecting Lead

WSM000001ELS0009US0

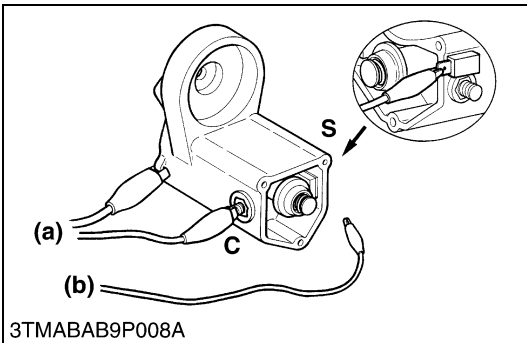

Magnet Switch Test (Pull-in, Holding Coils)

1. Remove the motor from the starter housing.
2. Prepare a 6 V battery for the test.
3. Connect jumper leads from the battery negative terminal to the housing and the starter **C** terminal.
4. The plunger should be attached and the pinion gear should pop out when a jumper lead is connected from the battery positive terminal to the **S** terminal. It is a correct.
5. Disconnect the jumper lead to the starter **C** terminal. Then the pinion gear should remain popped out. It is a correct.

■ IMPORTANT

- **Testing time must be 3 to 5 sec..**

(a) To Negative Terminal

(b) To Positive Terminal

9Y1211109ELS0029US0

(12) Safety Switch

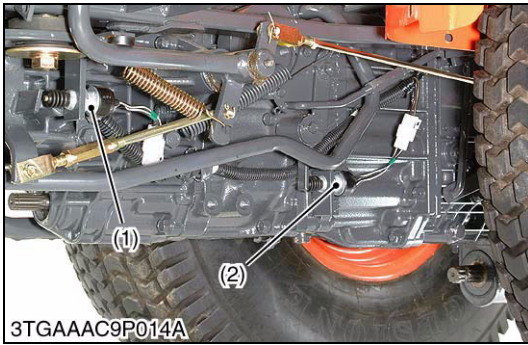

Safety Switch Continuity

1. Remove the safety switch leads.
2. Connect the circuit tester to the safety switch leads.
3. Measure the resistance between leads.
4. If the safety switch is defective, replace it.

Resistance Across switch terminal	When switch push is pushed	0 Ω
	When switch push is released	Infinity

(1) Safety Switch for Clutch Pedal (2) Safety Switch for HST

9Y1211109ELS0030US0

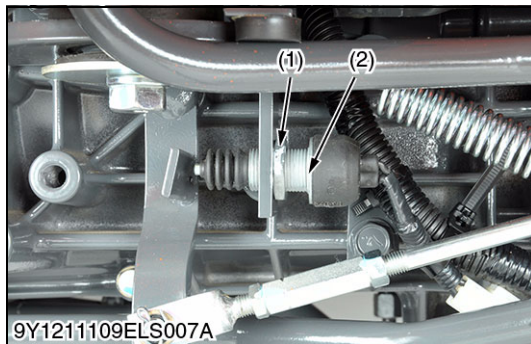

Adjusting Safety Switches

(Safety switch for clutch pedal)

1. Disconnect the safety switch connector and remove the safety switch (2) once.
2. Fully depress the clutch pedal and hold it.
3. Connect the leads of the ohmmeter to the safety switch lead terminal.
4. Screw in the safety switch (2) until the ohmmeter begins to show 0 ohm.
5. Further screw in the safety switch by 1/2 turn and tighten the lock nut (1).

(Safety switch for HST)

1. Disconnect the safety switch connector (3) and remove the safety switch (4) once.
2. Set the HST at neutral position.
3. Connect the leads of the ohmmeter to the safety switch lead terminal.
4. Screw in the safety switch (4) until the ohmmeter begins to show 0 ohm.
5. Further screw in the safety switch by 1/2 turn and tighten the lock nut (5).

(1) Lock Nut (2) Safety Switch (for Clutch Pedal) (3) Connector (4) Safety Switch (for HST) (5) Lock Nut

9Y1211109ELS0031US0

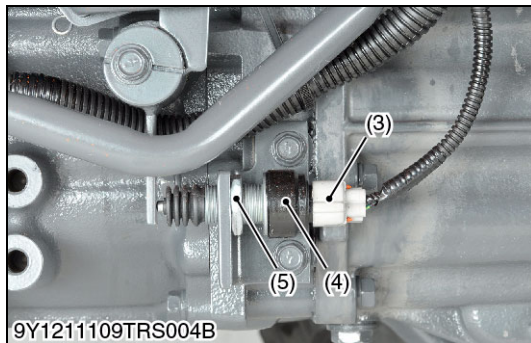

Seat Switch Continuity Check

1. Disconnect the seat switch leads.
2. Connect the circuit tester leads to the seat switch terminals.

(When seat switch is not pushed)

1. Measure the resistance between terminals.
2. If the continuity is not infinity, the switch is faulty, replace it.

(When seat switch is pushed)

1. Measure the resistance between terminals.
2. If the continuity is not 0 Ω, the switch is faulty, replace it.

Resistance	When seat switch is not pushed	Infinity
	When seat switch is pushed	0 Ω

(1) Seat Switch

9Y1211109ELS0032US0

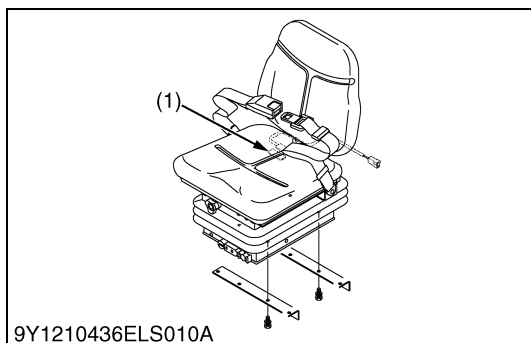

(13) Relay

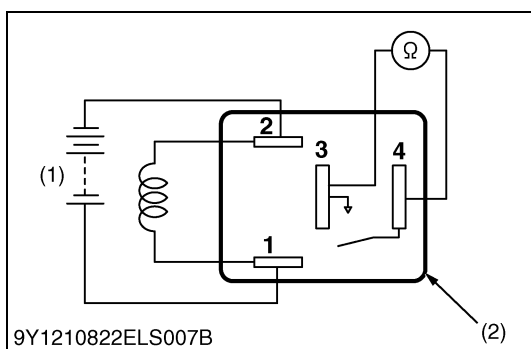
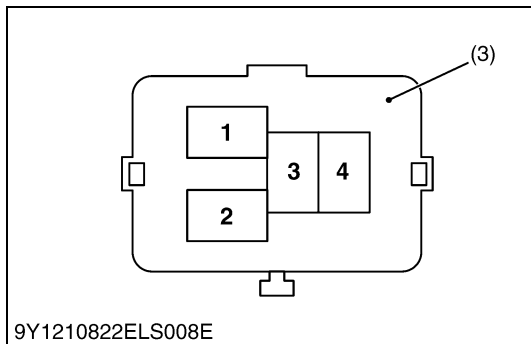
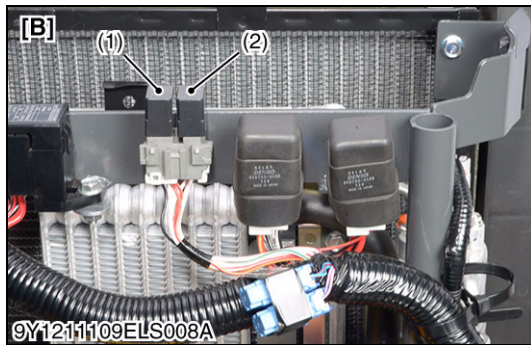
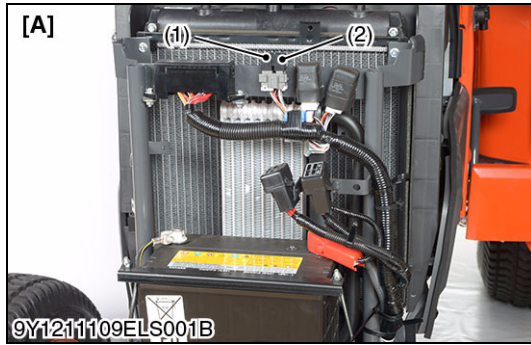

Relays

1) Checking Connector Voltage

1. Open the hood.
2. Remove the relays.
3. Measure the voltage with a voltmeter across the battery terminal and chassis as table below.
4. If the voltage differs from the battery voltage, the wiring harness or fuse is faulty.

Voltage	Terminal 4 – Chassis	Approx. battery voltage	
Resistance	3 terminal – 4 terminal	Battery voltage is applied across 1 terminal and 2 terminal	0 Ω

- (1) Head Light Relay
- (2) Flasher Relay
- (3) Connector (Wire Harness side)

[A] ROPS Model
[B] Cabin Model

9Y1211109ELS0040US0

Functional Check

NOTE

- The relays described here are used same ones so that these are interchangeable.

1. Apply the battery voltage across the terminal 1 and 2, and check for continuity across the terminal 3 and 4.
2. If continuity is not established across the terminal 3 and 4, replace it.

- (1) Battery
- (2) Connector (Relay)

9Y1211109ELS0041US0



Grow Relay (For ROPS)

1. Turn the main switch off and remove the glow relay (1).
2. Apply battery voltage across **3** and **4** terminals, and check for continuity across **1** and **2** terminals.
3. If continuity is not established across **1** and **2** terminals, renew the glow relay.

■ **NOTE**

- **The glow relay and the key stop relay are the same parts.**

Resistance	Terminal 1 – Terminal 2	0 Ω
------------	-------------------------	-----

(1) Glow Relay

9Y1211109ELS0042US0

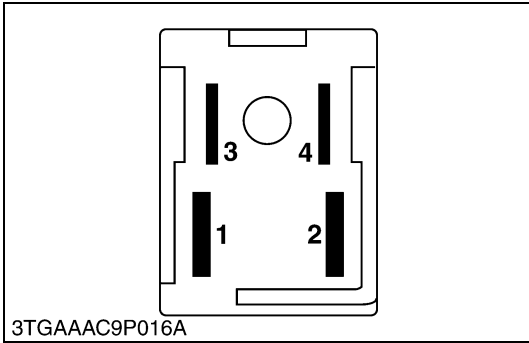

Electrical Outlet Relay (For Cabin)

1. Turn the main switch off and remove the electrical outlet relay (1).
2. Apply battery voltage across **3** and **4** terminals, and check for continuity across **1** and **2** terminals.
3. If continuity is not established across **1** and **2** terminals, renew the glow relay.

■ **NOTE**

- **The electrical outlet relay and the key stop relay are the same parts.**

Resistance	Terminal 1 – Terminal 2	0 Ω
------------	-------------------------	-----

(1) Electrical Outlet Relay

9Y1211109ELS0043US0

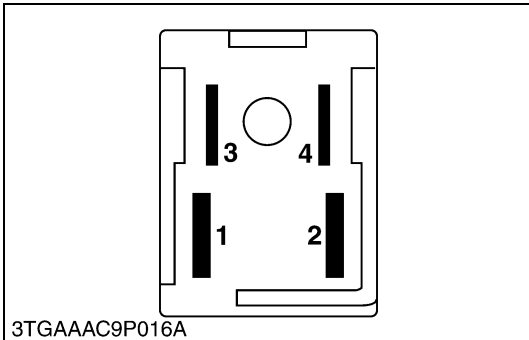

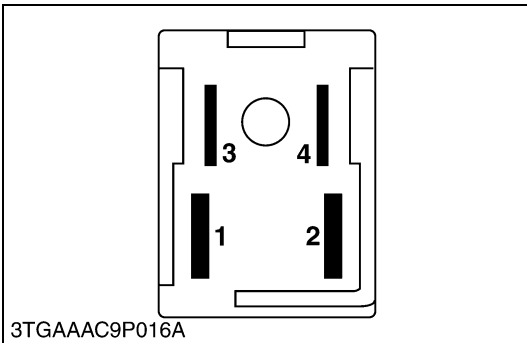

3TGAAAC9P016A

(14) QGS Controller for CABIN

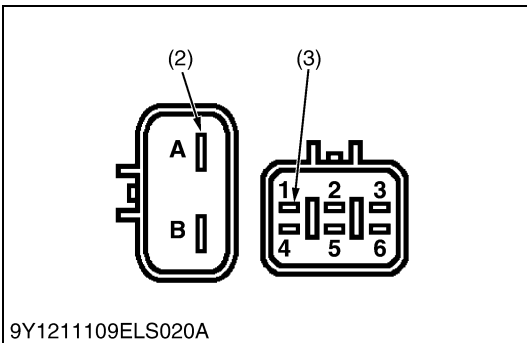
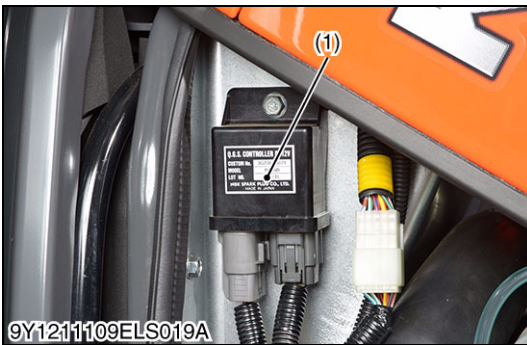

9Y1211109ELS020A

Key Stop Relay

1. Turn the main switch off and remove the key stop relay (1).
2. Apply battery voltage across 3 and 4 terminals, and check for continuity across 1 and 2 terminals.
3. If continuity is not established across 1 and 2 terminals, renew the key stop relay.

NOTE

- The glow relay and the key stop relay are the same parts.

Resistance	Terminal 1 – Terminal 2	0 Ω
------------	-------------------------	-----

(1) Key Stop Relay

[A] ROPS Model

[B] Cabin Model

9Y1211109ELS0044US0

QGS Controller Connector Voltage

1. Measure the voltage with a voltmeter across the battery terminal and chassis as table below.
2. If the voltage differs from wiring harness or fuse is damaged.

Voltage	Terminal A (2) – Chassis	Approx. battery voltage
	Terminal 1 (3) – Chassis	

(1) QGS Controller

(3) Terminal 1

(2) Terminal A

9Y1211109ELS0079US0

(15) Coolant Temperature Sensor for CABIN

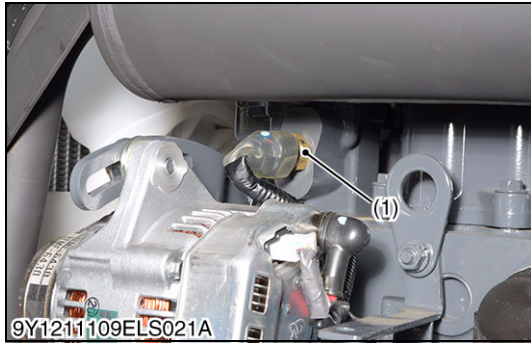

Checking Coolant Temperature Sensor

1. Disconnect the connector from the coolant temperature sensor (1).
2. Measure the resistance with an ohmmeter across the terminal 1 (2) and terminal 2 (3) of coolant temperature sensor (1).
3. If the measurement is not indicated, the sensor is damaged.

Resistance (Sensor terminal 1 – terminal 2)	Reference value	16.4 to 21.2 kΩ at -20 °C (-4 °F)
		1.04 to 1.23 kΩ at 40 °C (104 °F)
		0.15 to 0.16 kΩ at -100 °C (212 °F)

- (1) Coolant Temperature Sensor (3) Terminal 2
(2) Terminal 1

9Y1211109ELS0080US0

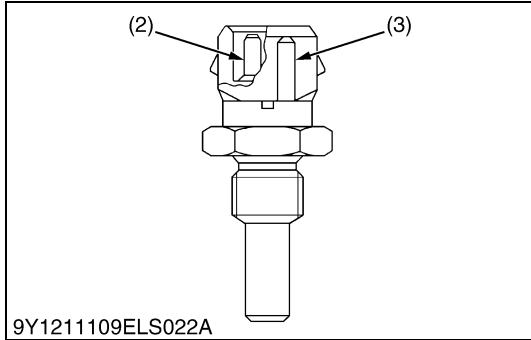

(16) OPC Controller



OPC Controller

1. Check the "Engine Starting Conditions" and "Automatic Engine Stop Conditions" (See page 9-M10).
2. If the tractor does not operate appropriately, check all parts according to the "1. TROUBLESHOOTING" section.
3. If all parts except the OPC controller (1) is not defective, replace the OPC controller (1),

- (1) OPC Controller

9Y1211109ELS0045US0

(17) Glow Plug

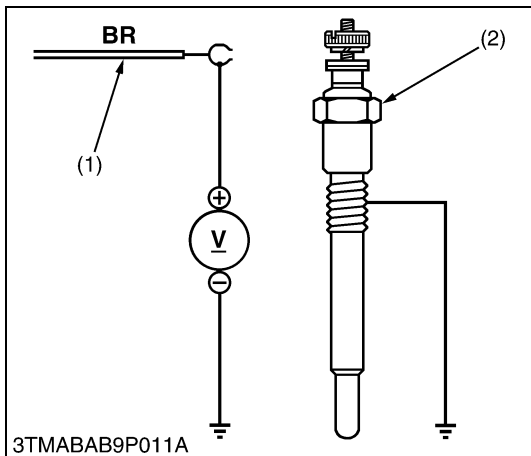

Lead Terminal Voltage

1. Disconnect the wiring lead (1) from the glow plug (2) after turning the main switch off.
2. Turn the main switch key to the "PREHEAT" position, and measure the voltage between the lead terminal and the chassis.
3. Turn the main switch key to the "START" position, and measure the voltage with a voltmeter between the lead terminal and the chassis.
4. If the voltage at either position differs from the battery voltage, the wiring harness or main switch is faulty.

Voltage (Lead terminal – Chassis)	Main switch key at "PREHEAT"	Approx. battery voltage
	Main switch key at "START"	Approx. battery voltage

- (1) Wiring Lead (2) Glow Plug

9Y1211109ELS0046US0

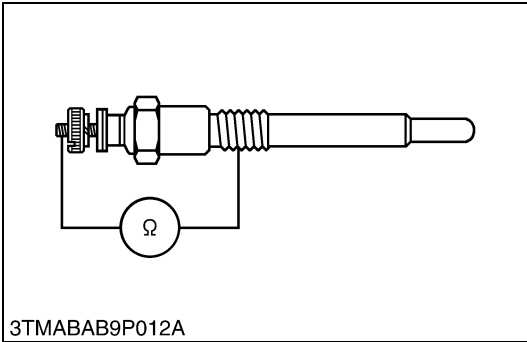

Glow Plug Continuity

1. Disconnect the leads from the glow plugs.
2. Measure the resistance with an ohmmeter between the glow plug terminal and chassis.
3. If 0 ohm is indicated, the screw at the tip of the glow plug and the housing are short-circuited.
4. If the factory specification is not indicated, the glow plug is faulty.

Glow plug resistance	Factory specification	Approx. 0.9 Ω
----------------------	-----------------------	---------------

9Y1211109ELS0047US0

(18) Key Stop Solenoid

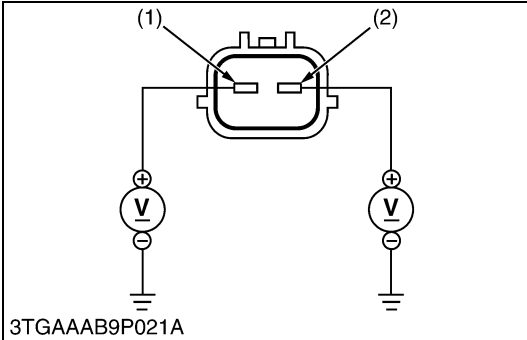

Connector Voltage

1. Disconnect the **2P** connector from key stop solenoid.
2. Turn the main switch key to the **"ON"** position.
3. Measure the voltage with voltmeter between the terminal **1** (Black / White), terminal **2** (White / Black) and body.
4. If the voltage differs from the battery voltage, the wiring harness or main switch is faulty.

Voltage	Terminal 1 – Body	Approx. battery voltage
	Terminal 2 – Body	Approx. battery voltage

(1) Terminal 2

(2) Terminal 1

9Y1211109ELS0048US0

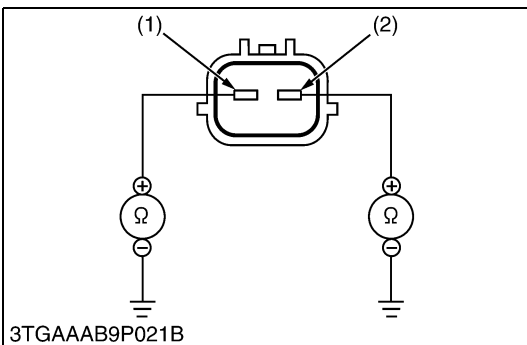

Stop Solenoid Coil

1. Disconnect the **2P** connector from key stop solenoid.
2. Measure the resistance with an ohmmeter between the terminal **1**, terminal **2** and body.
3. If resistance differs from the factory specification, the coil is faulty.

Resistance	Terminal 1 – Body (Pull-in Coil)	Approx. 0.375 Ω
	Terminal 2 – Body (Holding Coil)	Approx. 15.6 Ω

(1) Terminal 1 (Pulling Coil)

(2) Terminal 2 (Holding Coil)

9Y1211109ELS0049US0

(19) Alternator

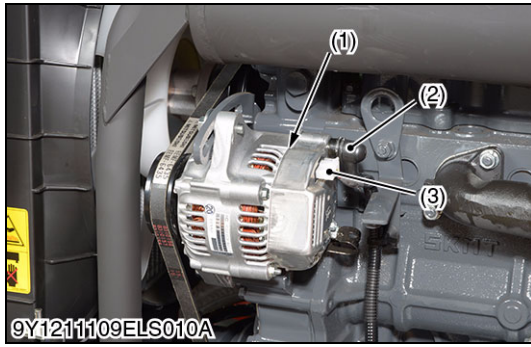

Alternator

1. Disconnect the **2P** connector (3) from alternator after turning the main switch **OFF**.
2. Perform the following checkings.

- (1) Alternator
- (2) **B** Terminal
- (3) **2P** Connector

9Y1211109ELS0050US0

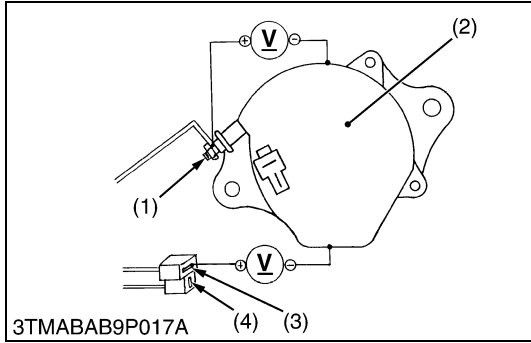

Connector Voltage

1. Turn the main switch **OFF**. Measure the voltage between the **B** terminal (1) and the chassis.
2. Turn the main switch **ON**. Measure the voltage between the **IG** terminal (3) and the chassis.

Voltage (Main switch at OFF)	B terminal – Chassis	Approx. battery voltage
Voltage (Main switch at ON)	IG terminal – Chassis	Approx. battery voltage

- (1) **B** Terminal
- (2) Alternator
- (3) **IG** Terminal
- (4) **L** Terminal

9Y1211109ELS0051US0

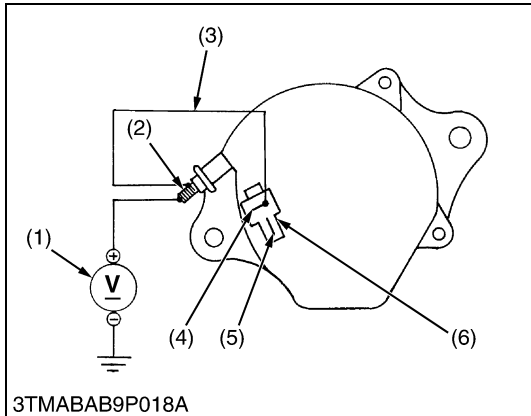

No-Load Test

1. Connect the **2P** connector (6) to previous positions of the alternator after turning the main switch **OFF**.
2. Connect the jumper lead (3) between **IG** terminal (4) and **B** terminal (2).
3. Start the engine and then set at idling speed.
4. Disconnect the negative cable from the battery.
5. Measure the voltage between the **B** terminal (2) and the chassis.
6. If the measurement is less than the factory specification, disassemble the alternator and check the IC regulator.

Voltage	Factory specification	More than 14 V
---------	-----------------------	----------------

(Reference)

- Once the engine has started, the alternator temperature rises quickly up to an ambient temperature of 70 to 90 °C (158 to 194 °F). As the temperature goes higher than 50 °C (122 °F), the alternator voltage slowly drops; at higher than 100 °C (212 °F), it drops by about 1 V.

- (1) Voltmeter
- (2) **B** Terminal
- (3) Jumper Lead
- (4) **IG** Terminal
- (5) **L** Terminal
- (6) **2P** Terminal

9Y1211109ELS0052US0

(20) Combination Switch

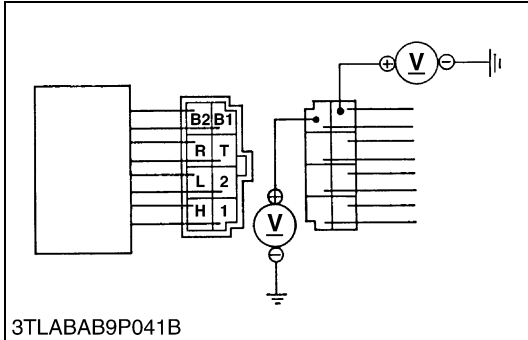
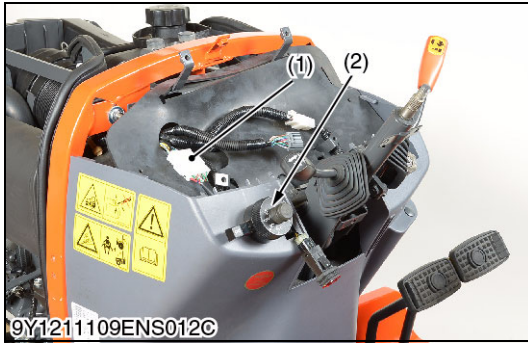

3TLABAB9P041B

Remove the Combination Switch

1. Remove the instrument panel, and disconnect the combination switch **8P** connector (1) after turning the main switch **OFF** position.
2. Perform the following checkings.

- (1) **8P** Connector (2) Combination Switch

9Y1211109ELS0053US0

1) Connector Voltage

1. Disconnect the **8P** connector from the combination switch.
2. Measure the voltage with a voltmeter across the connector **B1** terminal to chassis and the **B2** terminal to chassis when the main switch is "**OFF**" position.
3. If the voltage differs from the battery voltage, the wiring harness is faulty.

Voltage	Main switch at " OFF " position	B1 terminal – Chassis	Battery voltage
		B2 terminal – Chassis	

9Y1211109ELS0054US0

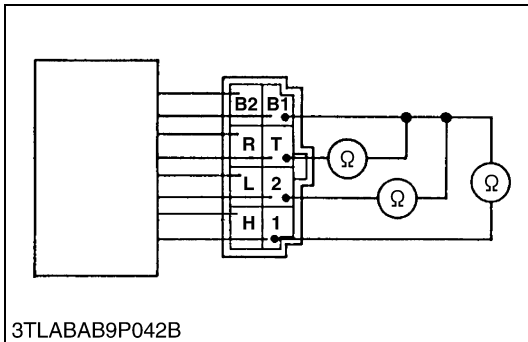

3TLABAB9P042B

2) Light Switch Continuity when Setting Switch at OFF Position

1. Disconnect the combination switch connector.
2. Set the light switch to the **OFF** position.
3. Measure the resistance with an ohmmeter across the **B1** terminal to the **T** terminal, the **B1** terminal to the **1** terminal and the **B1** terminal to the **2** terminal.
4. If infinity is not indicated, the head light switch is faulty.

Resistance (Switch at OFF position)	B1 terminal – T terminal	Infinity
	B1 terminal – 1 terminal	
	B1 terminal – 2 terminal	

9Y1211109ELS0055US0

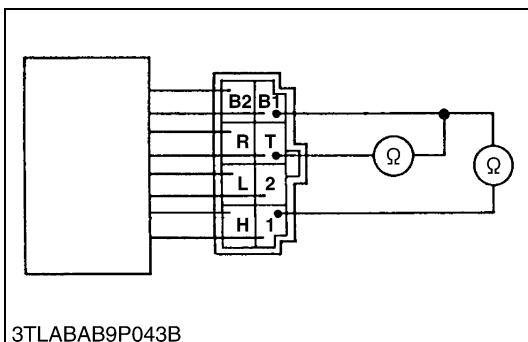

3TLABAB9P043B

3) Light Switch Continuity when Setting Switch at HIGH-BEAM

1. Measure the resistance with an ohmmeter across the **B1** terminal to the **T** terminal and the **B1** terminal to the **1** terminal.
2. If 0 ohm is not indicated, the head light switch is faulty.

Resistance (Switch at HIGH-BEAM position)	B1 terminal – T terminal	0 Ω
	B1 terminal – 1 terminal	

9Y1211109ELS0056US0

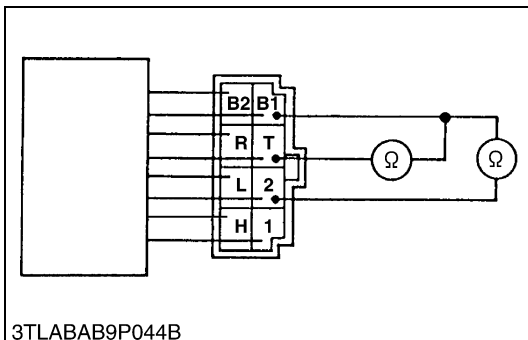

3TLABAB9P044B

4) Light Switch Continuity when Setting Switch at LOW-BEAM Position

1. Measure the resistance with an ohmmeter across the **B1** terminal to the **T** terminal and the **B1** terminal to the **2** terminal.
2. If 0 ohm is not indicated, the head light switch is faulty.

Resistance (Switch at LOW-BEAM position)	B1 terminal – T terminal	0 Ω
	B1 terminal – 2 terminal	

9Y1211109ELS0057US0

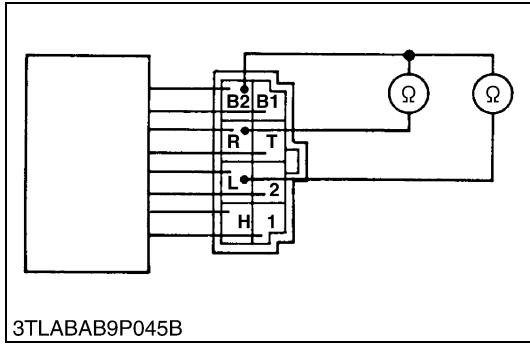

5) Turn Signal Light Switch when Setting Switch Knob at OFF Position

1. Set the turn signal light switch to the **OFF** position.
2. Measure the resistance with an ohmmeter across the **B2** terminal to the **R** terminal and the **B2** terminal to the **L** terminal.
3. If infinity is not indicated, the turn signal light switch is faulty.

Resistance (Switch at OFF position)	B2 terminal – R terminal	Infinity
	B2 terminal – L terminal	

9Y1211109ELS0058US0

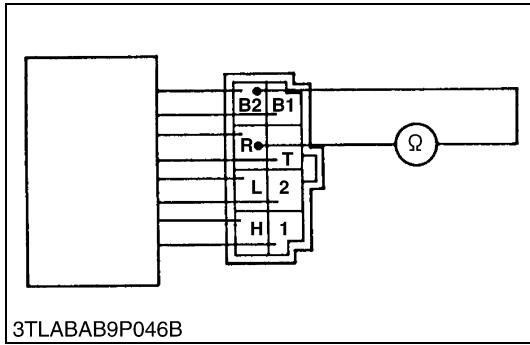

6) Turn Signal Light Switch when Setting Switch Knob at R Position

1. Set the turn signal light switch to the **R** position.
2. Measure the resistance with an ohmmeter across the **B2** terminal to the **R** terminal.
3. If 0 ohm is not indicated, the turn signal light switch is faulty.

Resistance (Switch at R position)	B2 terminal – R terminal	0 Ω
-----------------------------------	--------------------------	-----

9Y1211109ELS0059US0

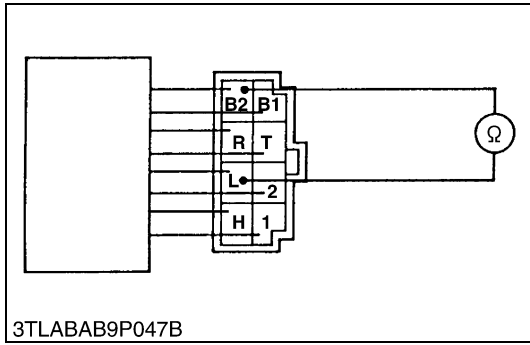

7) Turn Signal Light Switch when Setting Switch Knob at L Position

1. Set the turn signal light switch to the **L** position.
2. Measure the resistance with an ohmmeter across the **B2** terminal to the **L** terminal.
3. If 0 ohm is not indicated, the turn signal light switch is faulty.

Resistance (Switch at L position)	B2 terminal – L terminal	0 Ω
-----------------------------------	--------------------------	-----

9Y1211109ELS0060US0

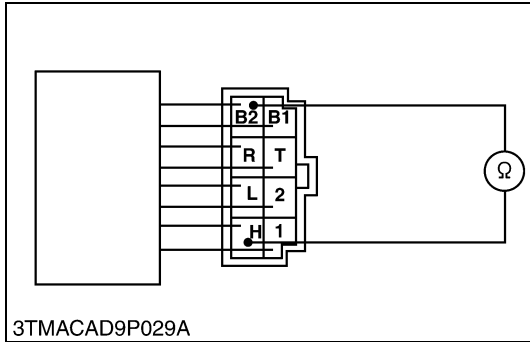

8) Horn Switch Continuity

1. Measure the resistance with an ohmmeter across the **B2** terminal to the **H** terminal.
2. If measurement is not following below, the horn switch is faulty.

Resistance (Switch at OFF)	B2 terminal – T terminal	Infinity
Resistance (Switch at ON)	B2 terminal – 2 terminal	0 Ω

9Y1211109ELS0061US0

(21) Hazard Switch



Hazard Switch

1. Remove the instrument panel and disconnect the **6P** connector (2) from hazard switch (1) after disconnect the battery negative code.
2. Remove the hazard switch (1).
3. Perform the following checking.

- (1) Hazard Switch (2) **6P** Connector

9Y1211109ELS0062US0

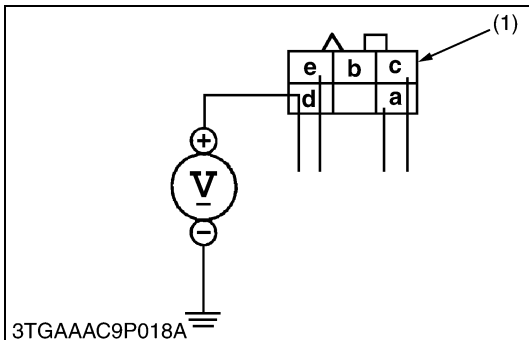

1) Connector Voltage

1. Connect the battery negative code, and turn on the light switch, then measure the voltage with a voltmeter across the **d** terminal and chassis.
2. If the voltage differ from the battery voltage, the wiring harness is faulty.

Voltage	d terminal – Chassis	Approx. battery voltage
---------	-----------------------------	-------------------------

- (1) **6P** Connector

9Y1211109ELS0063US0

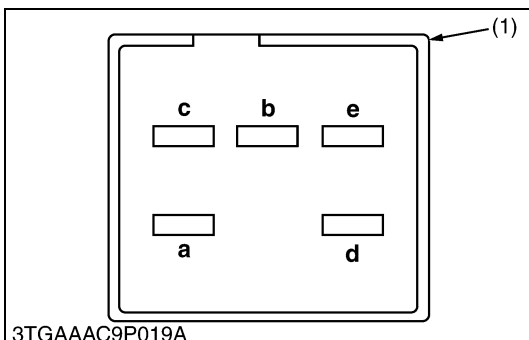

2) Hazard Switch Continuity

1. Measure the resistance with ohmmeter across the **a** terminal and **c** terminal, and across the **d** terminal and **e** terminal.
2. If the measurement is not following below, the hazard switch or the bulb are faulty.

Resistance (Switch at OFF)	a terminal – c terminal	Infinity
Resistance (Switch at ON)	a terminal – c terminal	0 Ω
Resistance (Bulb)	d terminal – e terminal	Approx. 50 Ω

- (1) Hazard Switch

9Y1211109ELS0064US0

(22) Beacon Switch

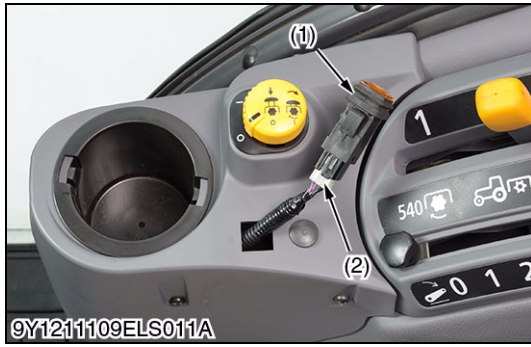

Beacon Switch

1. Disconnect the **6P** connector (2) from beacon switch (1) after disconnect the battery negative code.
2. Remove the beacon switch (1).
3. Perform the following checking.

(1) Beacon Switch

(2) **6P** Connector

9Y1211109ELS0065US0

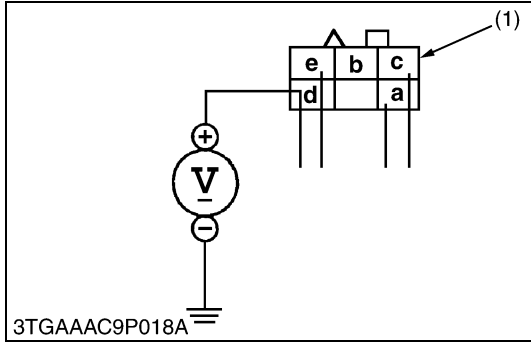

1) Connector Voltage

1. Connect the battery negative code, and turn on the light switch, then measure the voltage with a voltmeter across the **d** terminal and chassis.
2. If the voltage differ from the battery voltage, the wiring harness is faulty.

Voltage	d terminal – Chassis	Approx. battery voltage
---------	-----------------------------	-------------------------

(1) **6P** Connector

9Y1211109ELS0063US0

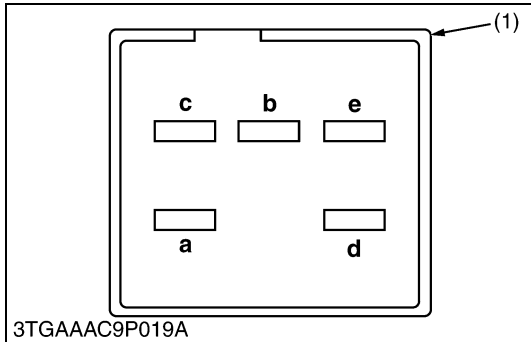

2) Beacon Switch Continuity

1. Measure the resistance with ohmmeter across the **a** terminal and **c** terminal, and across the **d** terminal and **e** terminal.
2. If the measurement is not following below, the beacon switch or the bulb are faulty.

Resistance (Switch at OFF)	a terminal – c terminal	Infinity
Resistance (Switch at ON)	a terminal – c terminal	0 Ω
Resistance (Bulb)	d terminal – e terminal	Approx. 50 Ω

(1) Beacon Switch

9Y1211109ELS0066US0

(23) Flasher Unit

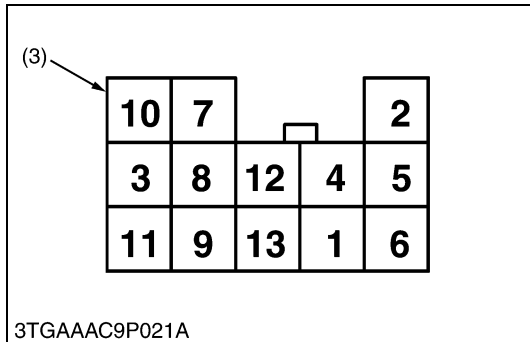
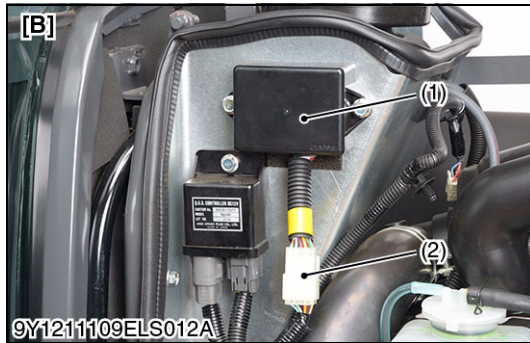
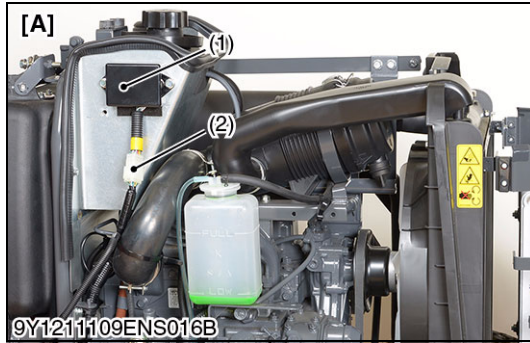

Flasher Unit Terminal Voltage

1. Disconnect the battery negative cable, and remove the hood and side cover.
2. Disconnect the flasher unit connector (2) and connect the battery ground cable.
3. Measure the voltage with a voltmeter between **12** terminal and **7** terminal, between **13** terminal and **7** terminal.
4. If the voltage differs from the battery voltage, the wiring harness is faulty.

Voltage	12 terminal – 7 terminal	Approx. battery voltage
	4 terminal – 7 terminal	Approx. battery voltage

(Reference)

1	0.5 Y	Lighting switch
2	0.85 Y	Licence Light
3	–	–
4	0.85 W/G	Main switch (IG)
5	0.5 G	Turn signal light (R)
6	0.5 G/R	Turn signal light switch (R)
7	0.5 B	Ground
8	0.5 Sb	Turn signal light (L)
9	0.5 G/Y	Turn signal light switch (L)
10	0.5 G/B	Trailer
11	0.5 W/L	Hazard switch
12	1.25 R/B	Battery Voltage
13	–	–

- (1) Flasher Unit
- (2) Flasher Unit Connector
- (3) Connector (Harness Side)

- [A] ROPS Model
- [B] Cabin Model

9Y1211109ELS0067US0

(24) Head Light

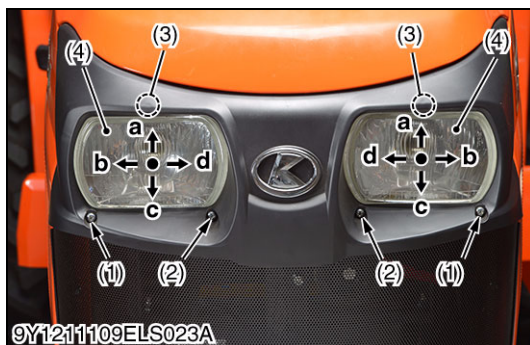

Adjustment of Optical Axis

1. Turn the adjustment screws (1), (2) and nuts (3) to the clockwise or counterclockwise.
2. Regarding the direction of optical axis shown in the table below.

	(1)	(2)	(3)
Clockwise	Inside	Outside	Up
Counterclockwise	Outside	Inside	Down

- (1) Screw
- (2) Screw
- (3) Nut
- (4) Head Light

- A: Clockwise
- B: Counterclockwise
- a: Up
- b: Outside
- c: Down
- d: Inside

9Y1211109ELS0081US0

(25) Brake Light Switch

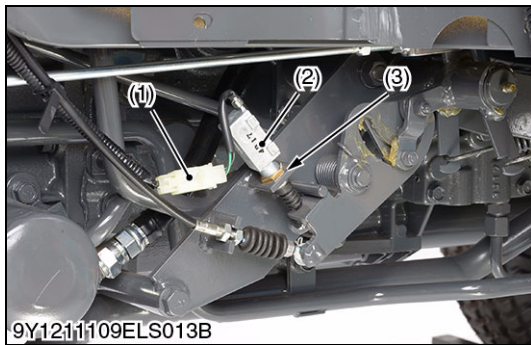
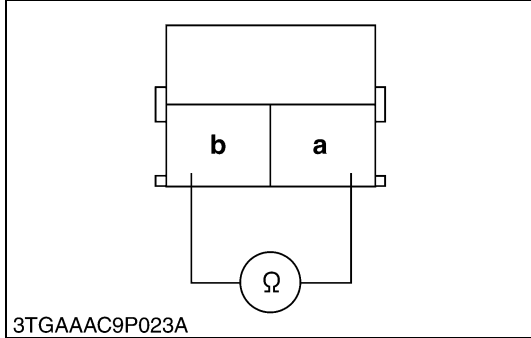
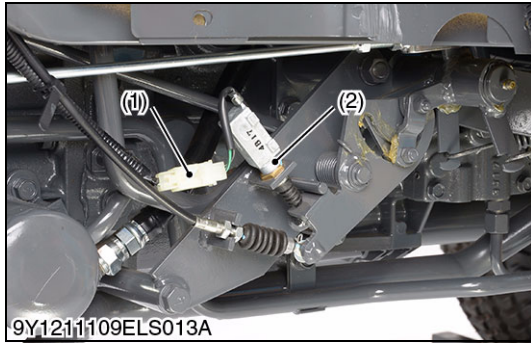

Brake Light Switch Continuity

1. Disconnect the **2P** connector (1), and measure the resistance with an ohmmeter across the brake switch leads.
2. If the measurement still differs from the table, replace the brake light switch.

Resistance (When the switch push is released)	a – b	0 Ω
Resistance (When the switch push is pushed)	a – b	Infinity

■ **NOTE**

- **Brake pedal free travel: 20 to 30 mm (0.79 to 1.18 in.)**

(1) **2P** Connector

(2) Brake Light Switch

9Y1211109ELS0068US0

Adjusting Brake Light Switch

1. Disconnect the connector (1) and remove the brake light switch (2) once.
2. Depress the brake within the range of free travel (20 to 30 mm (0.79 to 1.18 in.)) and hold it.
3. Connect the leads of the ohmmeter to the brake light switch lead terminal.
4. Screw in the brake light switch (2) until the ohmmeter begins to show "Infinity".
5. Further screw in the brake light switch by 1/2 turn and tighten the lock nut (3).

(1) Connector

(3) Lock Nut

(2) Brake Light Switch

9Y1211109ELS0069US0

(26) Switches for Indicator Lamps (Rear PTO, Mid PTO, Parking Brake and Oil Pressure)

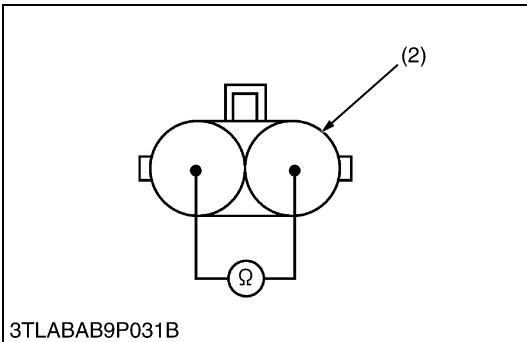
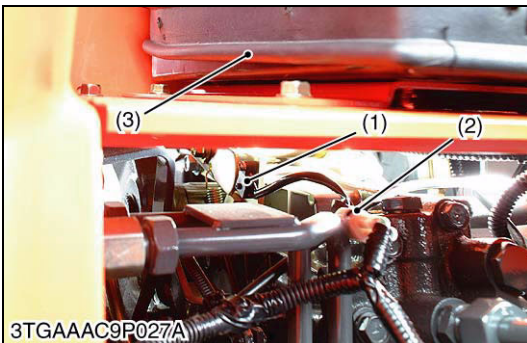
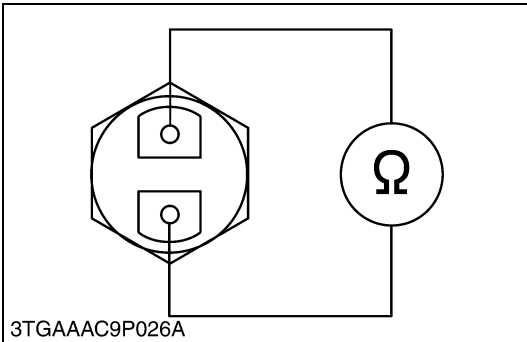
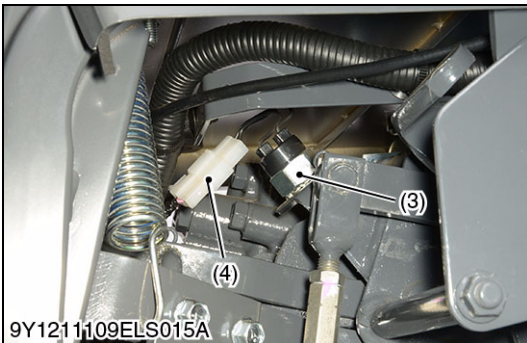
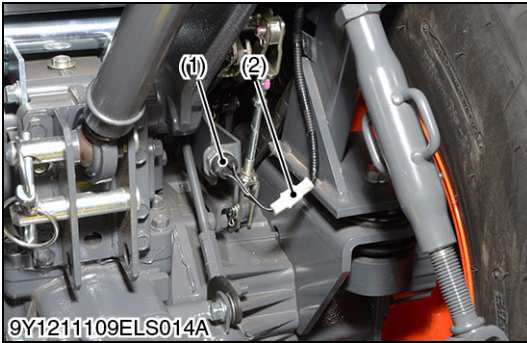

PTO Switches

1. Disconnect the PTO switch **2P** connector.
2. Measure the resistance of **2P** connector (switch side).
3. If the measurement differs from the table, replace it.

PTO Switch	State	Resistance
Rear PTO switch (1)	Rear PTO gear shift lever in neutral position	Infinity
	Rear PTO gear shift lever in 1st or 2nd speed position	0 Ω
Mid PTO switch (3)	Mid PTO gear shift lever at OFF position	Infinity
	PTO gear shift lever at ON position	0 Ω

NOTE

- **Rear PTO switch and mid PTO switch are the same parts.**

- | | |
|-------------------------|-------------------------|
| (1) Rear PTO Switch | (3) Mid PTO Switch |
| (2) 2P Connector | (4) 2P Connector |

9Y1211109ELS0070US0

Parking Brake Switch

1. Disconnect the connector from the parking brake switch (1) after turning the main switch **OFF**.
2. Measure the resistance across the two terminals.
3. If the measurement differs from the table below, the replace the switch.

Resistance (Across switch terminals)	Parking lever at off position	Infinity
		Parking lever pulled up

- | | |
|---------------------------------------|----------|
| (1) Parking Brake Switch | (3) Seat |
| (2) Connector of Parking Brake Switch | |

9Y1211109ELS0071US0

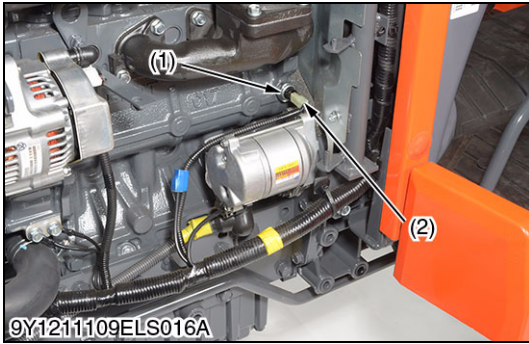

Engine Oil Pressure Switch

1. Disconnect the lead (2) from the engine oil pressure switch after turning the main switch **OFF**.
2. Turn the main switch **ON** and connect a jumper lead from the lead to the chassis.
3. If the engine oil pressure indicator lamp does not light, the panel circuit or the wiring harness is faulty.

- (1) Engine Oil Pressure Switch (a) From Oil Pressure Lamp
 (2) Switch Lead

9Y1211109ELS0072US0

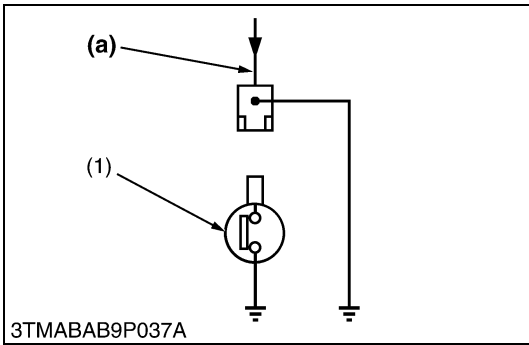

(27) Gauges

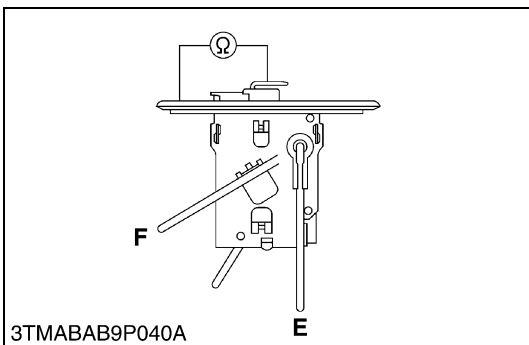

Fuel Level Sensor

1) Sensor Continuity

1. Remove the fuel level sensor from the fuel tank.
2. Measure the resistance with an ohmmeter across the sensor terminal and its body.
3. If the reference value are not indicated, the sensor is faulty.

Resistance (Sensor terminal – its body)	Reference value	Float at upper-most position	1 to 5 Ω
		Float at lower-most position	103 to 117 Ω

9Y1211109ELS0073US0

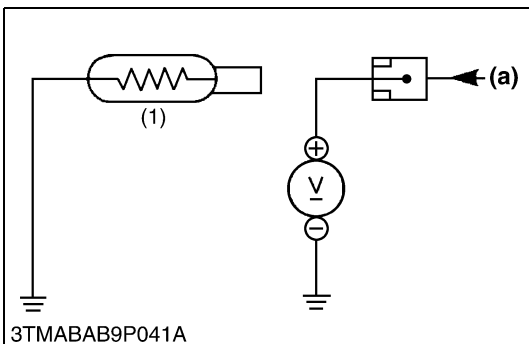

Coolant Temperature Sensor

1) Lead Terminal Voltage

1. Disconnect the lead from the coolant temperature sensor after turning the main switch off.
2. Turn the main switch on and measure the voltage with a voltmeter across the lead terminal and the chassis. If the voltage differs from the battery voltage, the wiring harness, fuse or coolant temperature gauge is faulty.

Voltage	Lead terminal – Chassis	Approx. battery voltage
---------	-------------------------	-------------------------

2) Sensor Continuity

1. Measure the resistances with an ohmmeter across the sensor terminal and the chassis.
2. If the reference value is not indicated, the sensor is faulty.

Resistance (Sensor terminal – Chassis)	Reference value	Approx. 16.1 Ω at 120 °C (248 °F)
		Approx. 27.4 Ω at 100 °C (212 °F)
		Approx. 51.9 Ω at 80 °C (176 °F)
		Approx. 153.9 Ω at 50 °C (122 °F)

- (1) Coolant Temperature Sensor (a) From Temperature Gauge

9Y1211109ELS0074US0

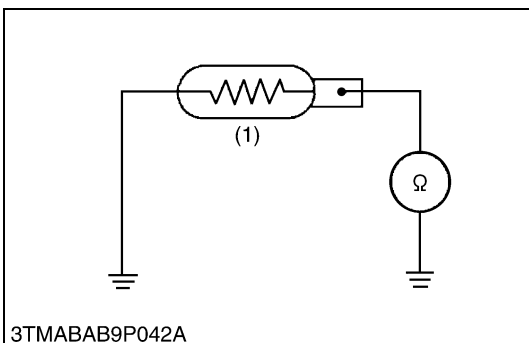

(28) Trailer Socket

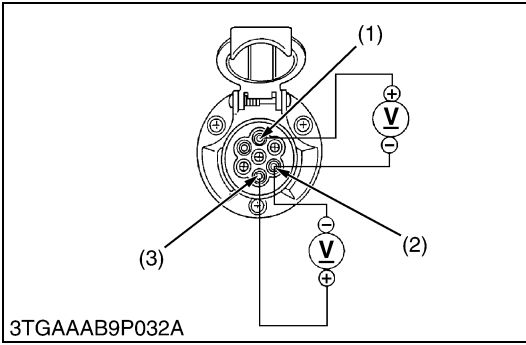

Trailer Socket

1) Turning Signal Terminals

1. Turn the main switch **ON**, and measure the voltage with voltmeter across the **1** terminal (1) and **3** terminal (2), and across the **4** terminal (3) and **3** terminal (2).
2. If the voltage differs from the battery voltage, the wiring harness or switches for turning signal are faulty.

Voltage (Turning signal switch at L or hazard switch at ON)	1 terminal (Green / White) – 3 terminal (Black)	Approx. battery voltage (Intermittently)
Voltage (Turning signal switch at R or hazard switch at ON)	4 terminal (Red / White) – 3 terminal (Black)	Approx. battery voltage (Intermittently)

- (1) **1** Terminal (3) **4** Terminal
 (2) **3** Terminal

9Y1211109ELS0075US0

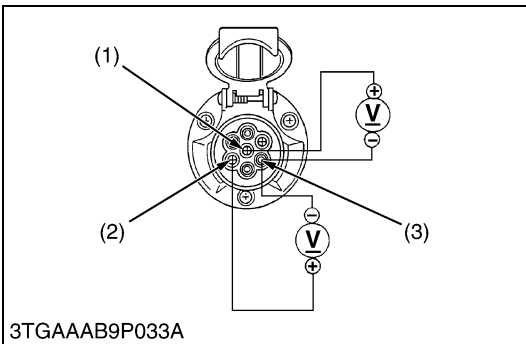

2) Tail Terminals

1. Turn the main switch **ON**, and measure the voltage with voltmeter across the **7** terminal (1) and **3** terminal (3), and across the **5** terminal (2) and **3** terminal (3).
2. If the voltage differs from the battery voltage, the wiring harness or switches for tail lights are faulty.

Voltage (Head light switch at ON , or position switch at ON)	7 Terminal (Yellow / Blue) – 3 Terminal (Black)	Approx. battery voltage
Voltage (Head light switch at ON , or position switch at ON)	5 Terminal (Blue / White) – 3 Terminal (Black)	Approx. battery voltage

- (1) **7** Terminal (3) **3** Terminal
 (2) **5** Terminal

9Y1211109ELS0076US0

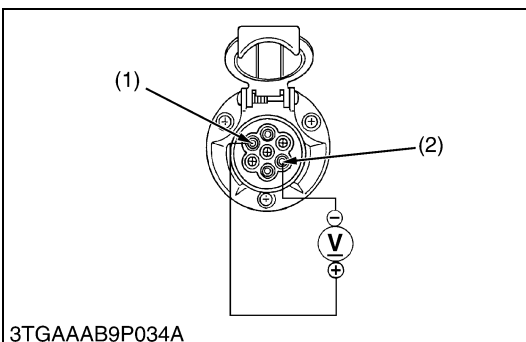

3) Brake Light Terminal

1. Turn the main switch **ON**, and measure the voltage with voltmeter across the **6** terminal (1) and **3** terminal (2).
2. If the voltage differs from the battery voltage, the wiring harness or switch for brake lights are faulty.

Voltage (When stepping the brake pedal)	6 Terminal (Yellow / Black) – 3 Terminal (Black)	Approx. battery voltage
---	--	-------------------------

- (1) **6** Terminal (2) **3** Terminal

9Y1211109ELS0077US0

[2] DISASSEMBLING AND ASSEMBLING

(1) Starter

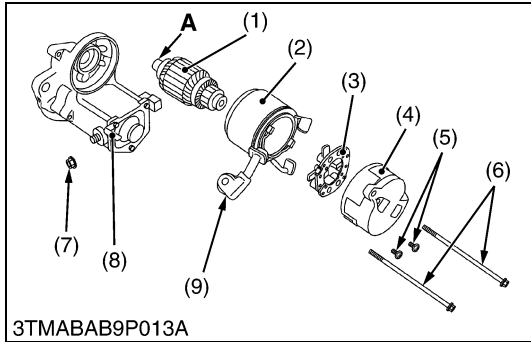

Disassembling Motor

1. Disconnect the connecting lead (9) from the magnet switch (8).
2. Remove the screws (6), and then separate the end frame (4), yoke (2) and armature (1).
3. Remove the two screws (5), and then remove the brush holder (3) from the end frame (4).

(When reassembling)

- Apply grease to the spline teeth "A" of the armature (1).

- | | |
|------------------|------------------------|
| (1) Armature | (7) Nut |
| (2) Yoke | (8) Magnet Switch |
| (3) Brush Holder | (9) Connecting Lead |
| (4) End Frame | |
| (5) Screw | |
| (6) Screw | A: Spline Teeth |

WSM000001ELS0020US0

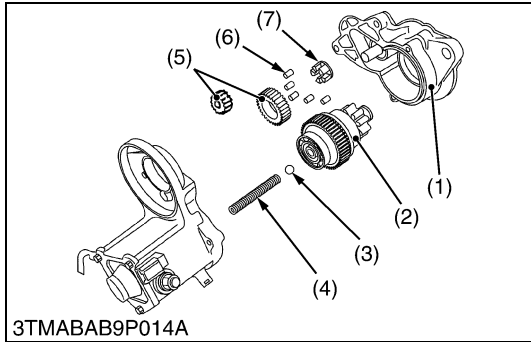

Disassembling Magnet Switch

1. Remove the drive end frame (1) mounting screws.
2. Remove the overrunning clutch (2), ball (3), spring (4), gears (5), rollers (6) and retainer (7).

(When reassembling)

- Apply grease to the gear teeth of the gears (5) and overrunning clutch (2), and ball (3).

- | | |
|------------------------|--------------|
| (1) Drive End Frame | (5) Gear |
| (2) Overrunning Clutch | (6) Roller |
| (3) Ball | (7) Retainer |
| (4) Spring | |

WSM000001ELS0021US0

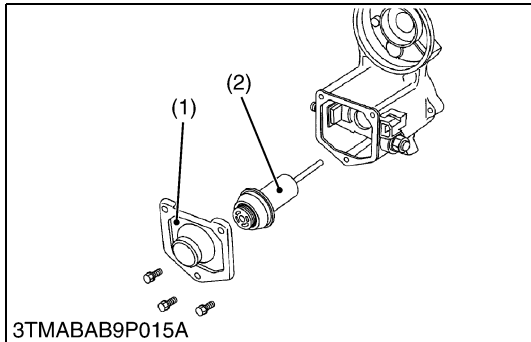

Plunger

1. Remove the end cover (1).
2. Remove the plunger (2).

- | | |
|---------------|-------------|
| (1) End Cover | (2) Plunger |
|---------------|-------------|

WSM000001ELS0022US0

(2) Alternator

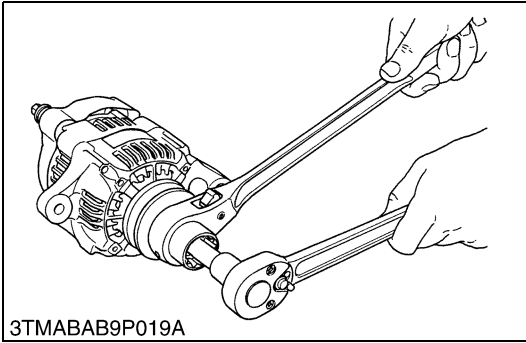

Pulley

1. Secure the hexagonal end of the pulley shaft with a double-ended ratchet wrench as shown in the figure.
2. Loosen the pulley nut with a socket wrench and remove it.

(When reassembling)

Tightening torque	Pulley nut	58.4 to 78.9 N·m 5.95 to 8.05 kgf·m 43.1 to 58.2 lbf·ft
-------------------	------------	---

WSM000001ELS0023US0

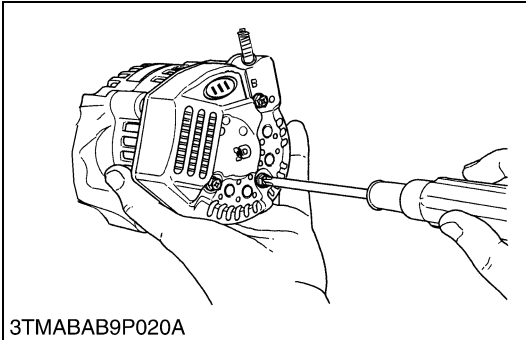

Rear End Cover

1. Remove the three rear end cover screws and the **B** terminal nut, and remove the rear end cover.

WSM000001ELS0024US0

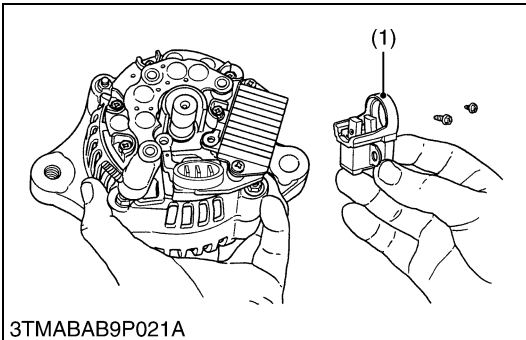

Brush Holder

1. Remove the two screws holding the brush holder, and remove the brush holder (1).

(1) Brush Holder

WSM000001ELS0025US0

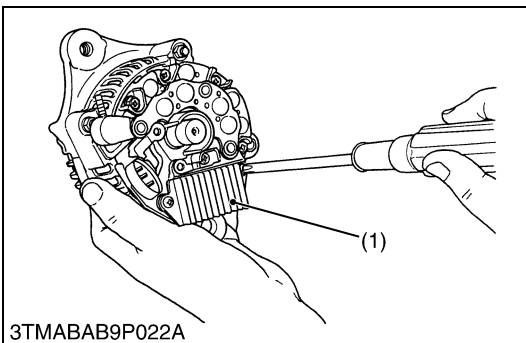

IC Regulator

1. Remove the three screws holding the IC regulator, and remove the IC regulator (1).

(1) IC Regulator

WSM000001ELS0026US0

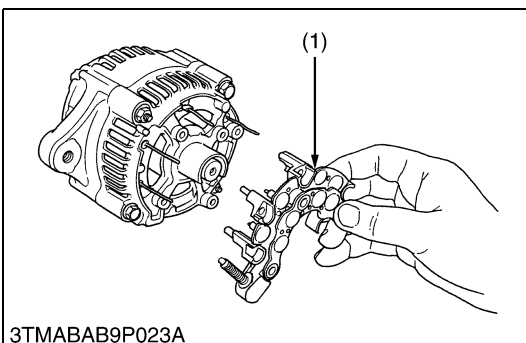

Rectifier

1. Remove the four screws holding the rectifier and the stator lead wires.
2. Remove the rectifier (1).

(1) Rectifier

WSM000001ELS0027US0

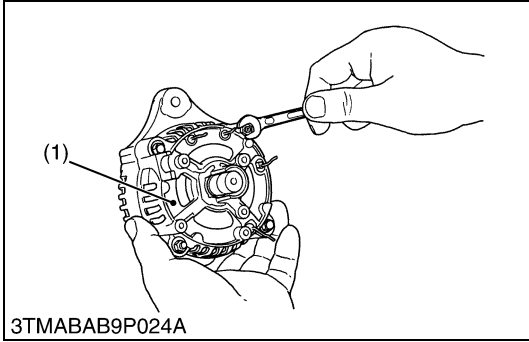

Rear End Frame

1. Remove the two nuts and two screws holding the drive end frame and the rear end frame.
2. Remove the rear end frame (1).

(1) Rear End Frame

WSM000001ELS0028US0

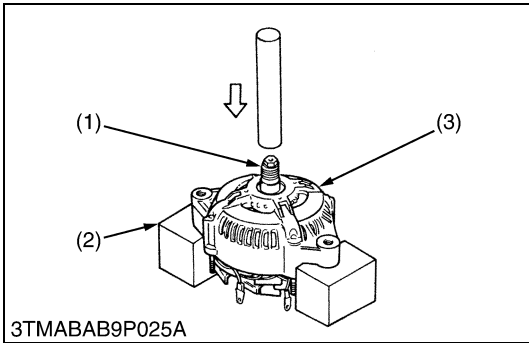

Rotor

1. Press out the rotor (1) from drive end frame (3).

■ **IMPORTANT**

- Be very careful not to drop the rotor and damage the slip ring or fan, etc..

(1) Rotor
(2) Block

(3) Drive End Frame

WSM000001ELS0029US0

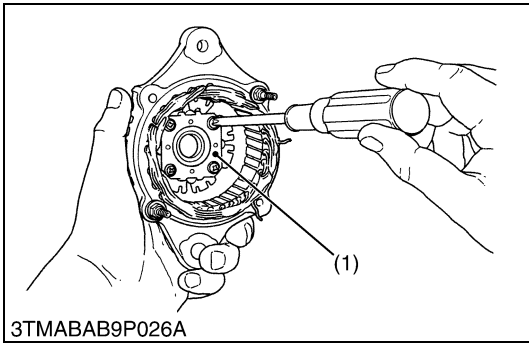

Retainer Plate

1. Remove the four screws holding the retainer plate, and remove the retainer plate (1).

(1) Retainer Plate

WSM000001ELS0030US0

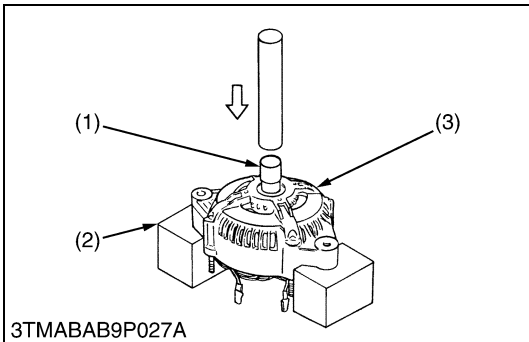

Bearing on Drive End Side

1. Press out the bearing from drive end frame (3) with a press and jig (1).

(1) Jig
(2) Block

(3) Drive End Frame

WSM000001ELS0031US0

[3] SERVICING

(1) Starter

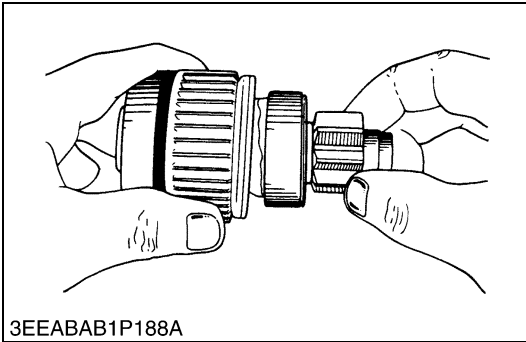

3EEABAB1P188A

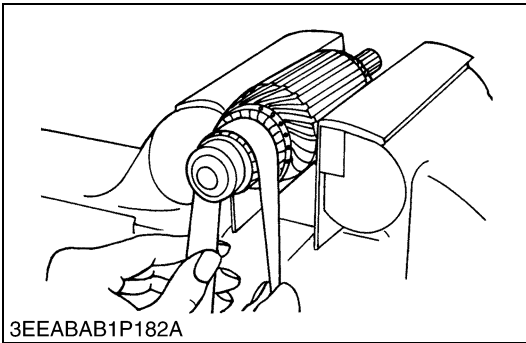

3EEABAB1P182A

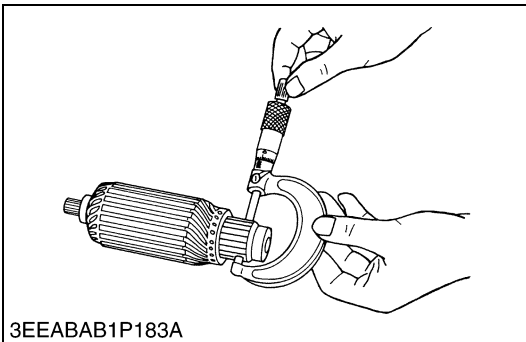

3EEABAB1P183A

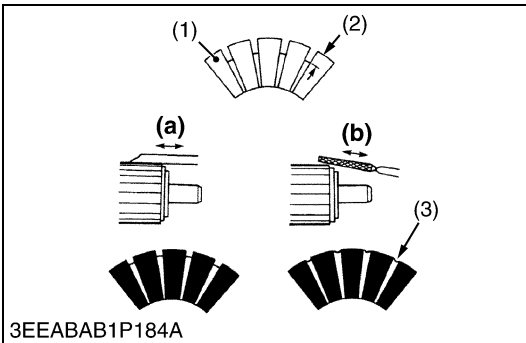

3EEABAB1P184A

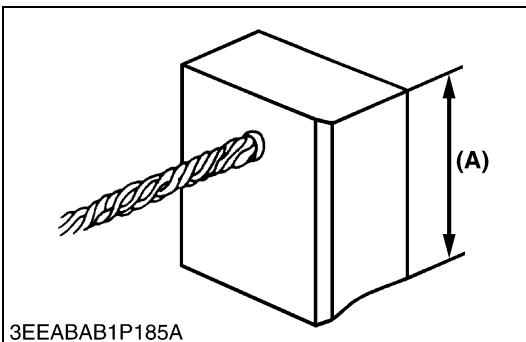

3EEABAB1P185A

Overrunning Clutch

1. Inspect the pinion for wear or damage.
2. If there is any problem, replace the overrunning clutch assembly.
3. Check that the pinion turns freely and smoothly in the overrunning direction and does not slip in the cranking direction.
4. If the pinion slips or does not rotate in the both directions, replace the overrunning clutch assembly.

WSM000001ELS0033US0

Commutator and Mica

1. Check the contact face of the commutator for wear, and grind the commutator with emery paper if it is slightly worn.
2. Measure the commutator O.D. with an outside micrometer at several points.
3. If the minimum O.D. is less than the allowable limit, replace the armature.
4. If the difference of the O.D.'s exceeds the allowable limit, correct the commutator on a lathe to the factory specification.
5. Measure the mica undercut.
6. If the undercut is less than the allowable limit, correct it with a saw blade and chamfer the segment edges.

Commutator O.D.	Factory specification	30.0 mm 1.181 in.
	Allowable limit	29.0 mm 1.142 in.

Difference of O.D.'s	Factory specification	Less than 0.02 mm 0.0008 in.
	Allowable limit	0.05 mm 0.0020 in.

Mica undercut	Factory specification	0.50 to 0.80 mm 0.020 to 0.031 in.
	Allowable limit	0.2 mm 0.008 in.

- | | |
|--------------|----------------------|
| (1) Segment | (a) Correct |
| (2) Undercut | (b) Incorrect |
| (3) Mica | |

WSM000001ELS0034US0

Brush Wear

1. If the contact face of the brush is dirty or dusty, clean it with emery paper.
2. Measure the brush length (A) with vernier calipers.
3. If the length is less than the allowable limit, replace the yoke assembly and brush holder.

Brush length (A)	Factory specification	15.0 mm 0.591 in.
	Allowable limit	11.0 mm 0.433 in.

WSM000001ELS0035US0

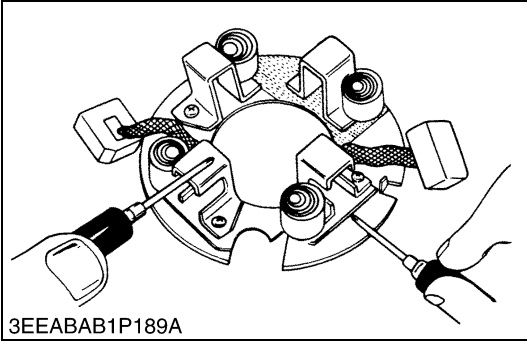

Brush Holder

1. Check the continuity across the brush holder and the holder support with an ohmmeter.
2. If it conducts, replace the brush holder.

Resistance	Brush holder – Holder support	Infinity
------------	-------------------------------	----------

WSM000001ELS0036US0

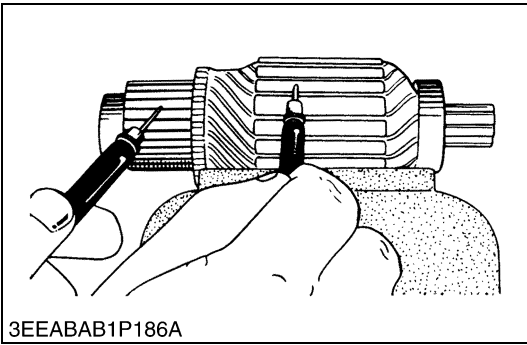

Armature Coil

1. Check the continuity across the commutator and armature coil core with an ohmmeter.
2. If it conducts, replace the armature.
3. Check the continuity across the segments of the commutator with an ohmmeter.
4. If it does not conduct, replace the armature.

WSM000001ELS0037US0

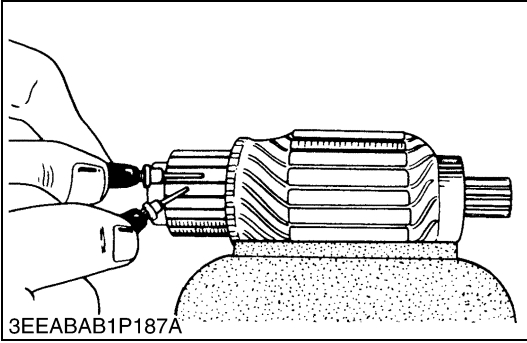

Field Coil

1. Check the continuity across the lead (1) and brush (2) with an ohmmeter.
2. If it does not conduct, replace the yoke assembly.
3. Check the continuity across the brush (2) and yoke (3) with an ohmmeter.
4. If it conducts, replace the yoke assembly.

- (1) Lead
- (2) Brush
- (3) Yoke

WSM000001ELS0038US0

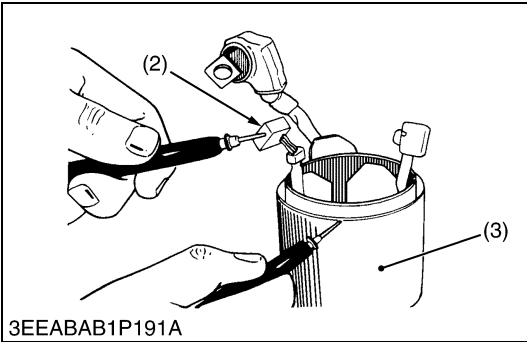
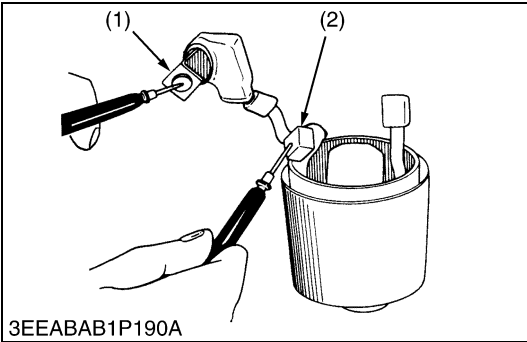

(2) Alternator

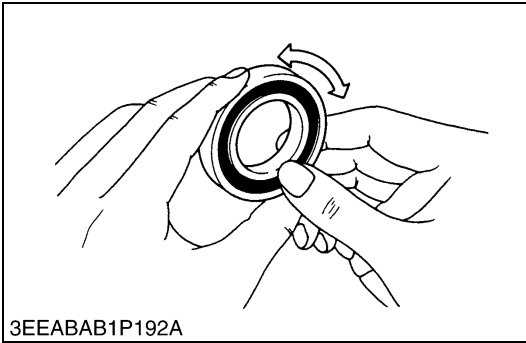

3EEABAB1P192A

Bearing

1. Check the bearing for smooth rotation.
2. If it does not rotate smoothly, replace it.

WSM000001ELS0039US0

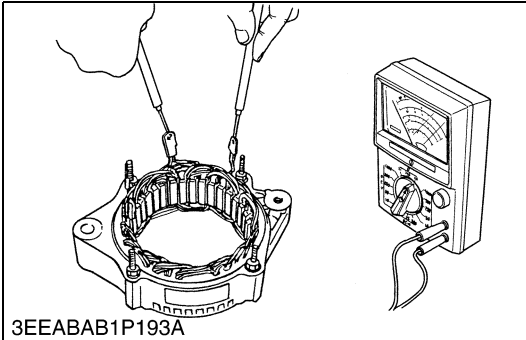

3EEABAB1P193A

Stator

1. Measure the resistance across each lead of the stator coil with an ohmmeter.
2. If the measurement is not within factory specification, replace it.
3. Check the continuity across each stator coil lead and core with an ohmmeter.
4. If the measurement is not within the factory specifications, replace it.

Resistance	Factory specification	Less than 1.0 Ω
------------	-----------------------	-----------------

WSM000001ELS0040US0

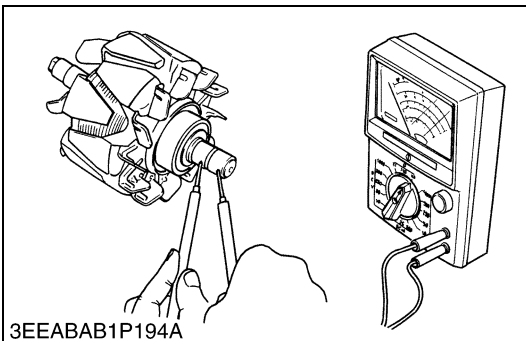

3EEABAB1P194A

Rotor

1. Measure the resistance across the slip rings with an ohmmeter.
2. If the resistance is not the factory specification, replace it.
3. Check the continuity across the slip ring and core with an ohmmeter.
4. If the measurement is not within the factory specifications, replace it.

Resistance	Factory specification	2.9 Ω
------------	-----------------------	-------

WSM000001ELS0041US0

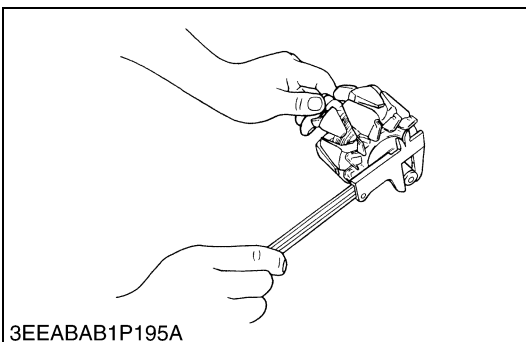

3EEABAB1P195A

Slip Ring

1. Check the slip ring for score.
2. If scored, correct with an emery paper or on a lathe.
3. Measure the O.D. of slip ring with vernier calipers.
4. If the measurement is less than the allowable limit, replace it.

Slip ring O.D.	Factory specification	14.4 mm 0.567 in.
	Allowable limit	14.0 mm 0.551 in.

WSM000001ELS0042US0

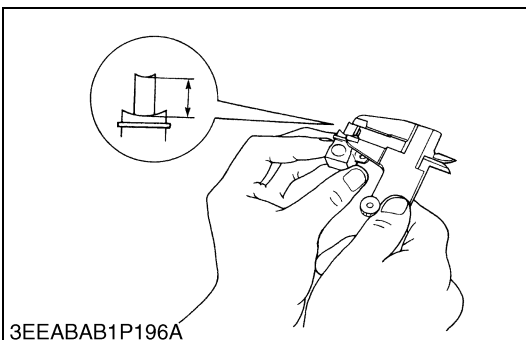

3EEABAB1P196A

Brush Wear

1. Measure the brush length with vernier calipers.
2. If the measurement is less than allowable limit, replace it.
3. Make sure that the brush moves smoothly.
4. If the brush is damaged, replace it.

Brush length	Factory specification	10.5 mm 0.413 in.
	Allowable limit	8.4 mm 0.331 in.

WSM000001ELS0043US0

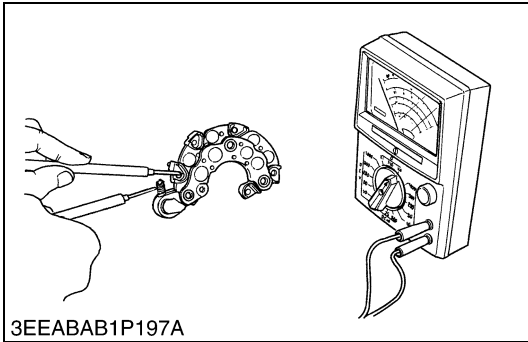

Rectifier

1. Check the continuity across each diode of rectifier with an analog ohmmeter. Conduct the test in the (R x 1) setting.
2. The rectifier is normal if the diode in the rectifier conducts in one direction and does not conduct in the reverse direction.

■ IMPORTANT

- Do not use a 500 V megohmmeter for measuring because it will destroy the rectifier.

■ NOTE

- Do not use an auto digital multimeter. Because it's very hard to check the continuity of rectifier by using it.

WSM000001ELS0044US0

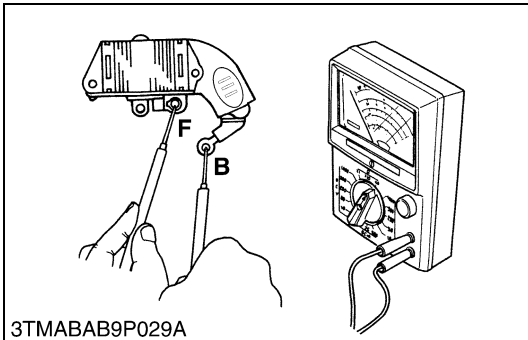

IC Regulator

1. Check the continuity across the **B** terminal and the **F** terminal of IC regulator with an analog ohmmeter. Conduct the test in the (R x 1) setting.
2. The IC regulator is normal if the IC regulator conducts in one direction and does not conduct in the reverse direction.

■ IMPORTANT

- Do not use a 500 V megohmmeter for measuring because it will destroy the IC regulator.

■ NOTE

- Do not use an auto digital multimeter. Because it is very hard to check the continuity of IC regulator by using it.

WSM000001ELS0045US0

10 CABIN

MECHANISM

CONTENTS

1. AIR CONDITIONER SYSTEM.....	10-M1
[1] OUTLINE OF AIR CONDITIONING SYSTEM.....	10-M1
2. REFRIGERATION SYSTEM	10-M3
[1] COMPRESSOR.....	10-M3
(1) Pressure Relief Valve	10-M4
(2) Magnetic Clutch.....	10-M4
[2] CONDENSER.....	10-M5
[3] RECEIVER	10-M6
[4] AIR CONDITIONER UNIT	10-M7
3. SYSTEM CONTROL	10-M8
4. ELECTRICAL SYSTEM.....	10-M9
[1] ELECTRICAL CIRCUIT	10-M9
[2] RELAY	10-M10

1. AIR CONDITIONER SYSTEM

[1] OUTLINE OF AIR CONDITIONING SYSTEM

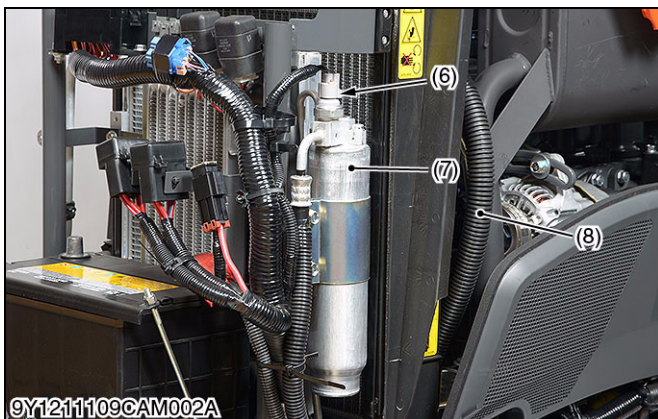
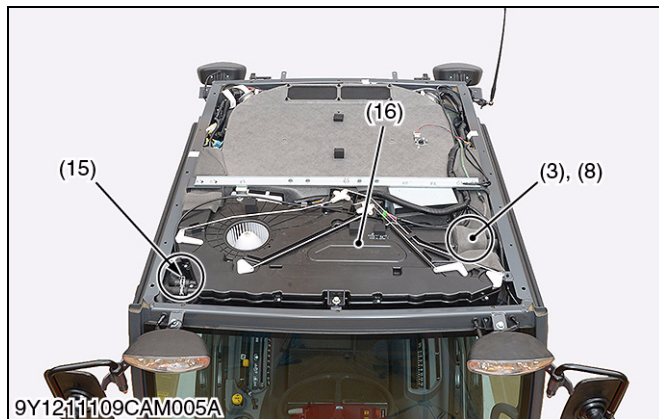
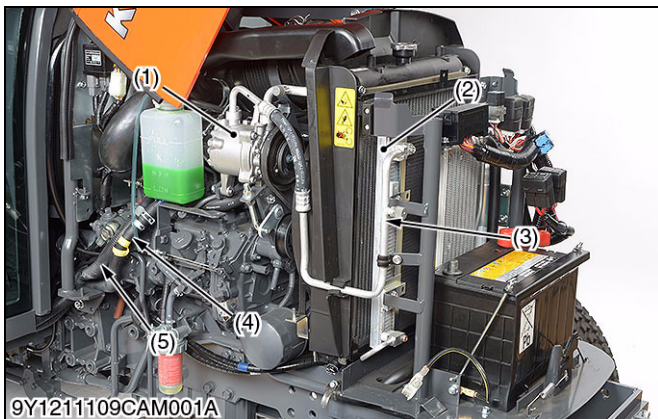

- | | |
|-------------------------------|---------------------------|
| (1) Compressor | (9) Outside Air Filter |
| (2) Condenser | (10) Side Air Outlet |
| (3) High Pressure Pipe | (11) Control Panel |
| (4) Heater Hose (Inlet Side) | (12) Front Air Outlet |
| (5) Heater Hose (Outlet Side) | (13) Inside Air Filter |
| (6) Pressure Switch | (14) Inner Roof |
| (7) Receiver | (15) Water Valve |
| (8) Low Pressure Pipe | (16) Air Conditioner Unit |

(To be continued)

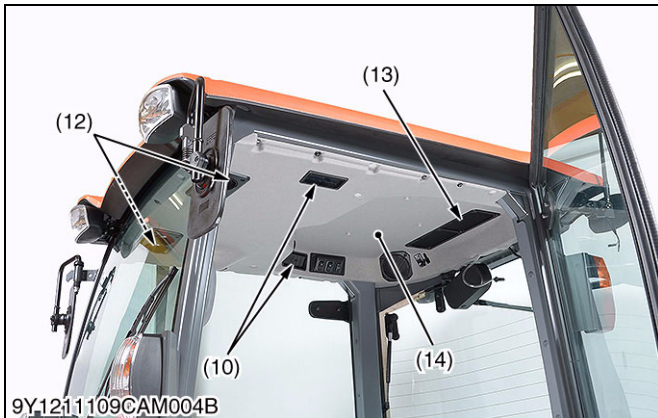
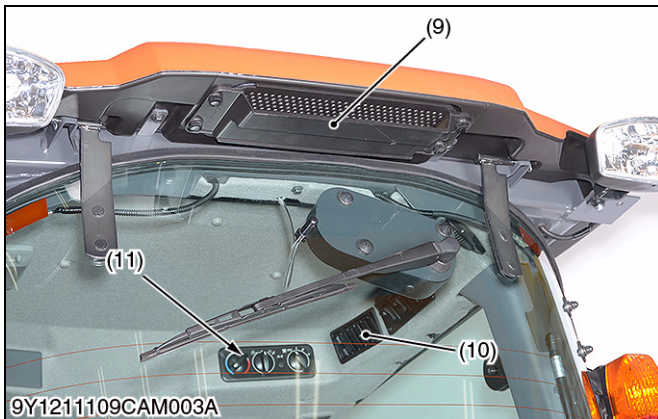

(Continued)

The machine is equipped with a thin large-capacity air conditioner with outside air intake. Through the inside air filter (13) as well as the outside air filter (9), the inner roof (14) and reaches the air conditioner unit (16). The air is then cooled and dehumidified by this unit.

The resulting air is heated to a comfortable level. In this way, the air being blown via the blow port can be kept at comfortable temperature and humidity.

The front air outlet (12) can be opened and closed using the center knob of each port. The side air outlet (10) are opened and closed using the mode lever on the control panel (11). With these ports open or closed, you can feel your head cool and your feet warm.

Capacity (Cooling)	Factory specification	2.8 to 3.4 kW
Capacity (Warming)	Factory specification	Water
	Water	3.8 to 4.7 kW
	LLC* 50 %	3.6 to 4.4 kW
Kinds of refrigerant (Charge amount)	Factory specification	R134a 630 to 730 g 1.39 to 1.61 lbs
Pressure sensor (Low)	Factory specification	0.196 MPa 2.0 kgf/cm ² 28.4 psi
Pressure sensor (High)	Factory specification	3.14 MPa 32.0 kgf/cm ² 455 psi

*LLC: Anti-freeze

■ **NOTE**

- As for the mechanism and function of each component part, refer to "10. CABIN" section in the Workshop Manual of "MECHANISM" (9Y021-18200).

9Y1211109CAM0001US0

2. REFRIGERATION SYSTEM

[1] COMPRESSOR

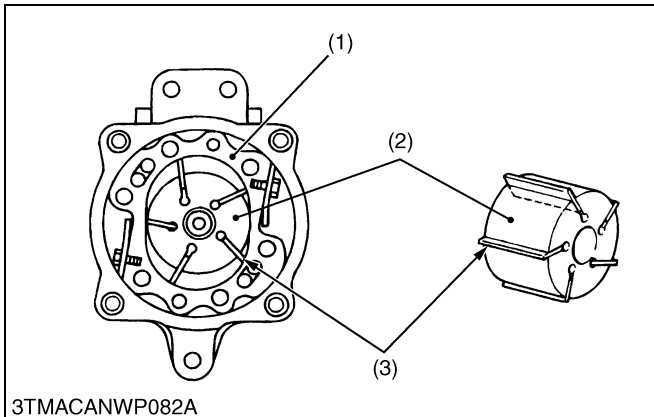

The vane type compressor installed on this cabin consists of a cylinder (1) with an oval cross section and a rotor (2) with five vanes (3). The vane type compressor is provided with two suction ports and two discharge ports respectively.

The five vanes (3) mounted on the rotor (2), rotating along the inner wall of the cylinder (1), keeps air-tightness using the centrifugal force of the rotor (2) and the back pressure of the vanes (3) that grow in proportion to the rotating speed of the rotor (2).

As a result, the volumes of the five cylinder chambers separated with the cylinder (1) and the five vanes (3) change.

For each rotation of the rotor (2), each of the cylinder chambers performs two cycles of inhalation, compression, and discharge.

- (1) Cylinder
- (2) Rotor
- (3) Vane

9Y1211109CAM0002US0

Operation

In proportion to the rotation of the rotor (3), a volume of a cylinder chamber separated with the cylinder (1) and the vanes (4) increases. The cylinder chamber inhales refrigerant gas from the suction port (2).

As the rotor (3) rotates further, a volume of the cylinder chamber separated with the cylinder (1) and the vanes (4) decreases, and the refrigerant gas is compressed. As the rotor (3) rotates even further, the refrigerant gas is highly compressed and then presses the discharge valve to open. The refrigerant gas is discharged from the discharge port (5).

- (1) Cylinder
- (2) Suction Port
- (3) Rotor
- (4) Vane
- (5) Discharge Port
- (A) Compression Process
- (B) Discharge Process
- (C) Suction Process

9Y1211109CAM0003US0

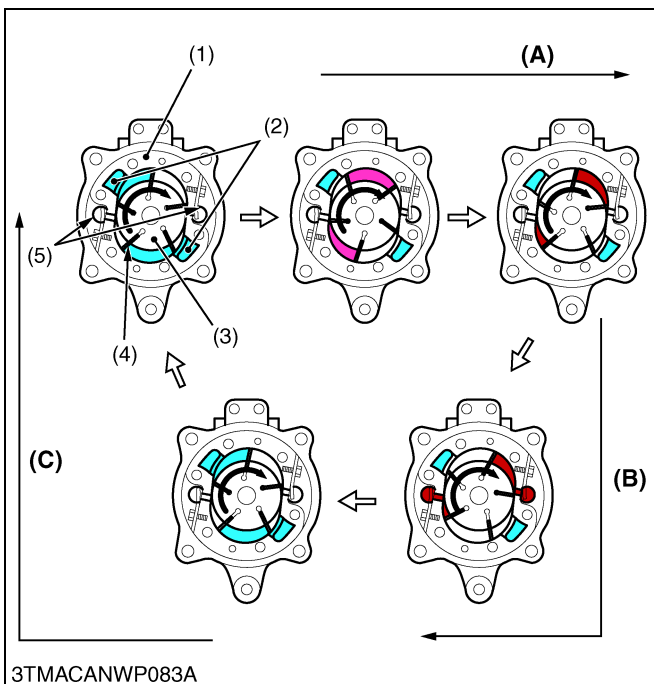

Compressor Oil

The compressor oil dissolves in the refrigerant, circulates through the air-conditioning cycle, and functions to lubricate the compressor. But the conventional compressor oil for R12 does not dissolve in R134a, so it does not circulate through the cycle, and the lifespan of the compressor is considerably shortened.

It is still essential to ensure that the correct refrigerant oil is used. R12 systems were lubricated with mineral oil, which is totally unsuitable for R134a systems. The letter require PAG oil, which mixes very well with the refrigerant and provides ideal lubrication throughout the system.

Quantity (Total)	Brand Name
110 to 120 cc 0.116 to 0.126 U.S.qts 0.0968 to 0.105 Imp.qts	ND-OIL 8 <PAG* oil>

*PAG: Polyalkyleneglycol (Synthetic oil)

9Y1211109CAM0004US0

(1) Pressure Relief Valve

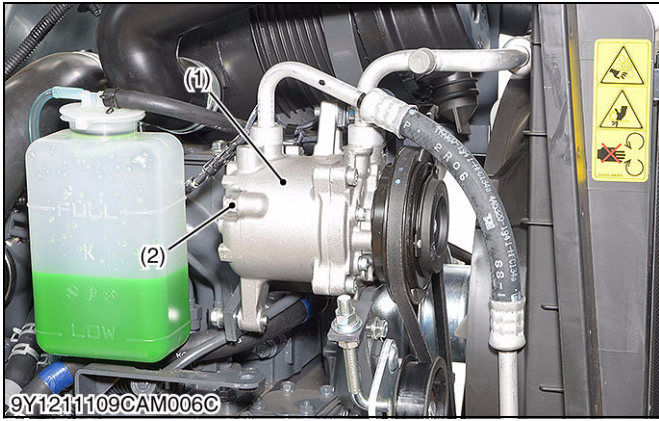

If the high pressure is abnormally high, the pressure relief valve (1) opens to protect the circuit.

Even in the worst case, the outflow of refrigerant is stopped at the minimum limit.

(Reference)

- In normal operation, the high pressure switch is triggered first and the compressor stops, so the pressure relief valve is not triggered so easily.

- (1) Compressor
- (2) Pressure Relief Valve

9Y1211109CAM005US0

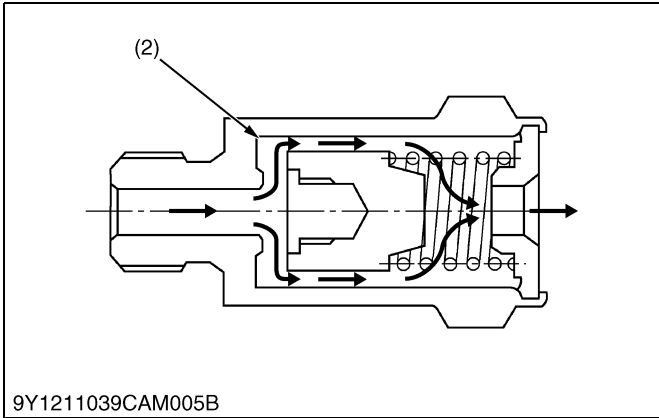

9Y1211039CAM005B

(2) Magnetic Clutch

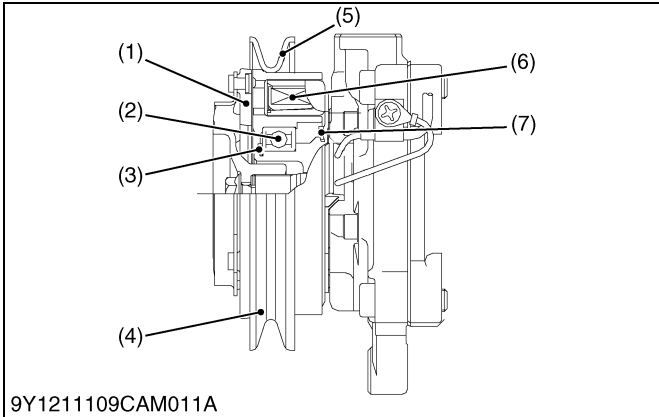

9Y1211109CAM011A

A magnetic clutch is used to engage and disengage the compressor from the engine. Main components are stator (6), rotor with pulley (5), and pressure plate (1) to engage the drive pulley (4) and compressor (8) magnetically.

The stator is fixed on the compressor housing, and the pressure plate (1) is attached to the compressor shaft. Two ball bearings (2) are used between the inner surface of the rotor and the front housing of the compressor.

- (1) Pressure Plate
- (2) Ball Bearing
- (3) Circlip
- (4) Pulley
- (5) Rotor with Pulley
- (6) Stator
- (7) Circlip
- (8) Compressor

9Y1211109CAM0006US0



9Y1211109CAM006B

[2] CONDENSER

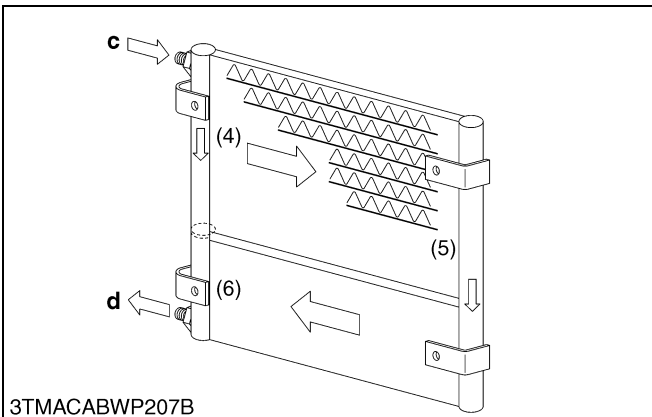
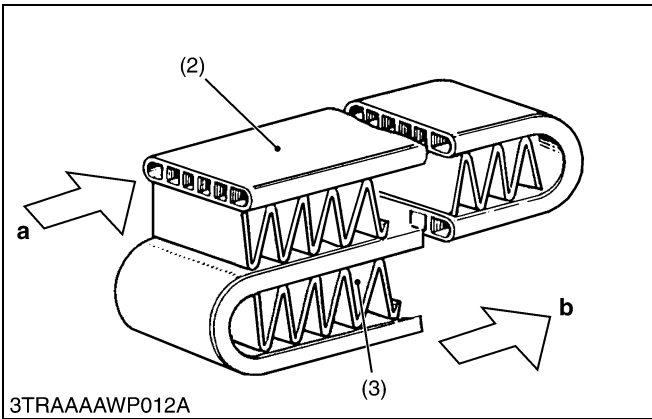
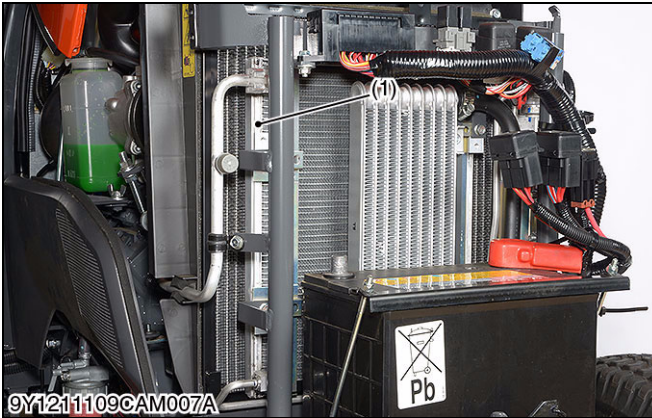

The condenser (1) is installed in the front of the radiator to enable forced cooling by the air drawn in by the engine radiator fan.

The condenser is used for the purpose of cooling by robbing the heat from the refrigerant gas, which has been compressed by the compressor into high temperature, high pressure gas, and change this gas into liquid refrigerant.

The heat given off by the gaseous refrigerant in the condenser is the sum of the heat absorbed at the evaporator and the heat of work required by the compressor to compress the refrigerant. The greater the amount of heat is given off in the condenser, the greater the cooling effect attainable by the evaporator in the cabin.

- (1) Condenser
- (2) Tube
- (3) Fin
- (4) Vapor
- (5) Liquefying
- (6) Liquefied

- a: Gaseous Refrigerant
- b: Liquid Refrigerant
- c: Heated Vapor from Compressor (70 °C, 158 °F)
- d: Cooled Liquid to Receiver (50 °C, 122 °F)

9Y1211109CAM007US0

[3] RECEIVER

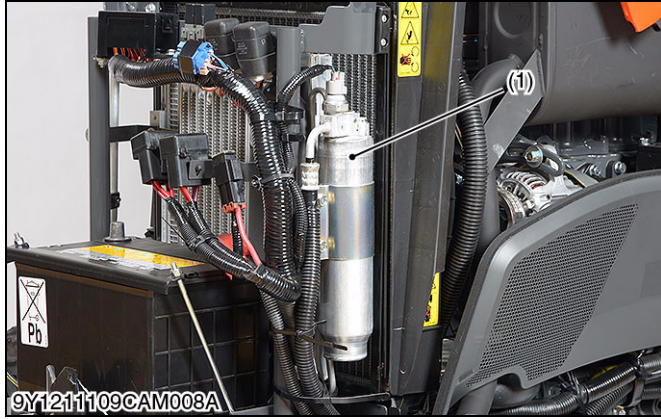

The receiver serves the purpose of storing the liquid refrigerant. The amount of liquid refrigerant flowing through the system varies with the operating condition of the air conditioner. To be accurate, the receiver stores excess refrigerant when the heat load is lowered. It also releases stored refrigerant when additional cooling is needed, thus, keeping the optimum flow of refrigerant within the system.

The receiver includes a desiccant (2). It has the job of removing moisture as the refrigerant circulates within the system.

The sight glass is installed on the top of the receiver. The amount of refrigerant that is charged has a direct effect on the efficiency of the air conditioner. The sight glass is used to check the amount of refrigerant. If a large flow of bubbles can be seen in the sight glass, there is insufficient refrigerant charged. If so, fill the refrigerant to the proper level.

- (1) Receiver Body
- (2) Desiccant

- a: IN
- b: OUT

9Y1211109CAM0008US0

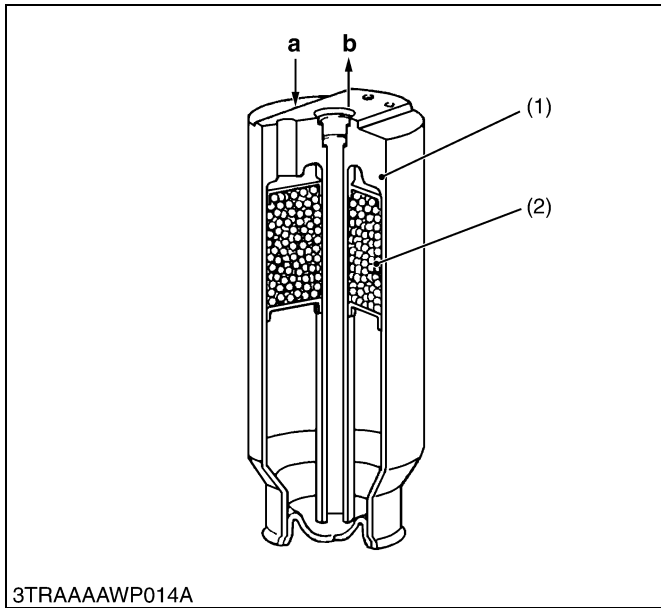

[4] AIR CONDITIONER UNIT

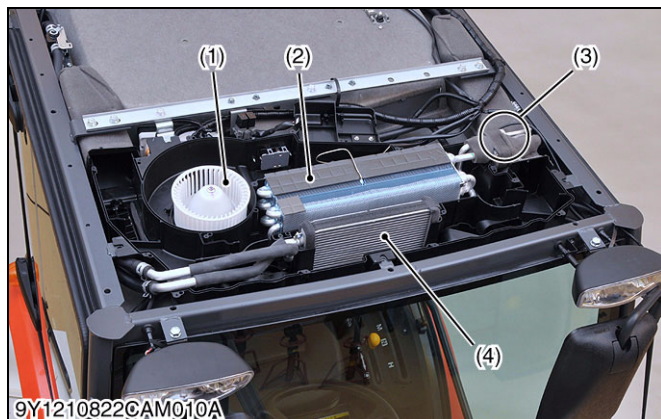

The air conditioner unit consists of evaporator (2), expansion valve (3), heater core (4), blower (1) etc..

- (1) Blower
- (2) Evaporator
- (3) Expansion Valve
- (4) Heater Core

9Y1211109CAM009US0

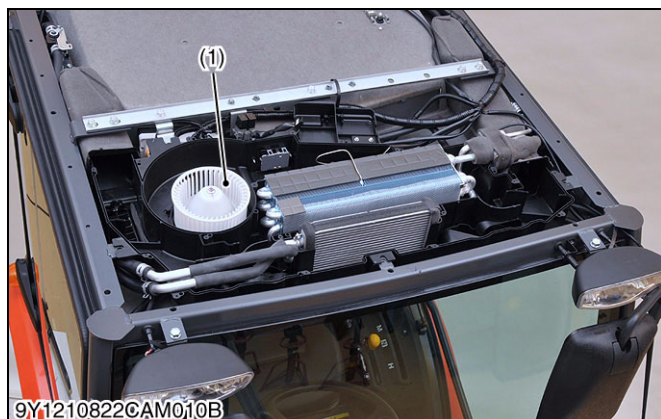

A/C Blower

The blower is incorporated in the left-hand space of the air conditioner unit. It blows cool, warm or fresh air via the dashboard and defroster blow ports into the cabin.

The speed of the blower motor (2) can be adjusted in 4 steps by the resistor (3).

The blower fan (1) is centrifugal type. The air being sucked in parallel with the rotary shaft is blown in the centrifugal direction; in other words, perpendicular to the rotary shaft.

- (1) Blower Fan
- (2) Blower Motor
- (3) Resistor

9Y1211109CAM0010US0

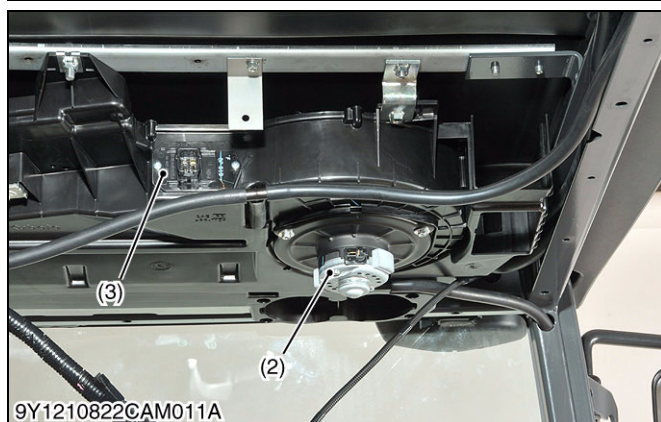

NOTE

- As for the mechanism and function of each component part, refer to "10. CABIN" section in the Workshop Manual of tractor mechanism (Code No. 9Y021-18200).

9Y1211109CAM0011US0

3. SYSTEM CONTROL

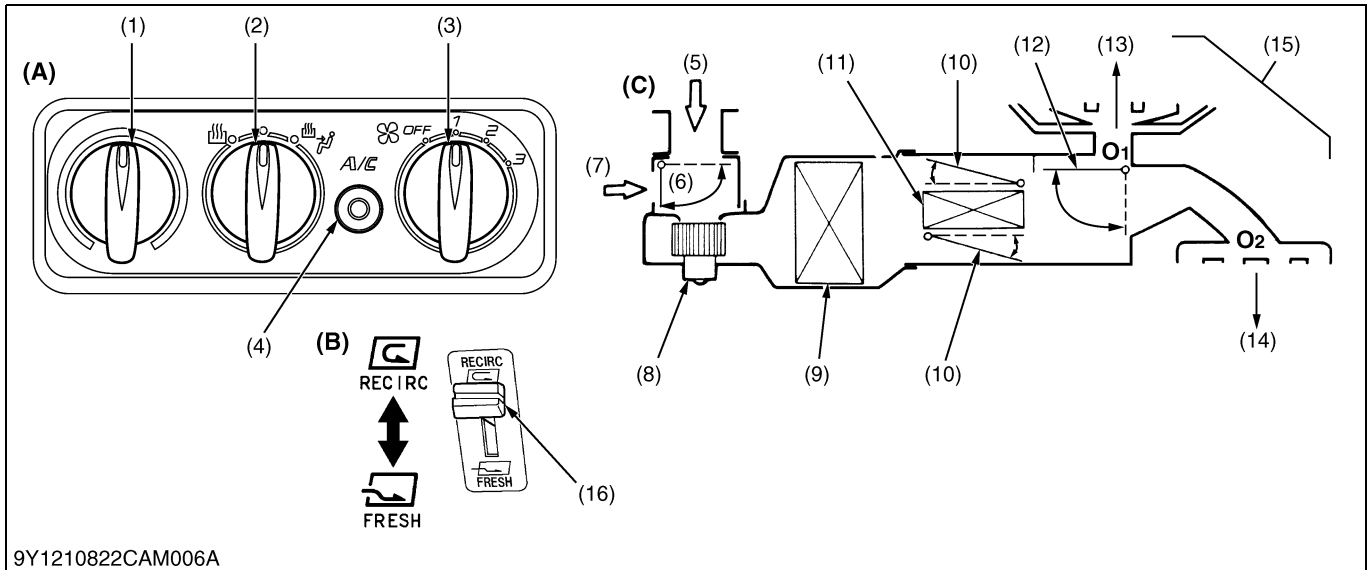

9Y1210822CAM006A

- | | | | |
|---|---|-------------------------------------|--|
| (1) Temperature Control Dial | (7) Recirculated Air | (12) Air Outlet Door D3 (Mode Door) | (A) Control Plate |
| (2) Mode Switch | (8) Blower | (13) DEFOGGER | (B) Air Selection Lever |
| (3) Blow Switch | (9) Evaporator | (14) FACE | (C) Block Diagram of Air Flow Passage |
| (4) Air Conditioner Switch with Indicator Light | (10) Temperature Door D2 (Air Mixed Door) | (15) DEF and FACE | O1: Front air outlet |
| (5) Fresh Air | (11) Heater | (16) Air Selection Lever | O2: Side air outlet |
| (6) Air Intake Door D1 | | | |

1) Selection of recirculated air (7) or fresh air (5) is done with door D1.

■ **RECIRC**

By setting the air selection lever (16) in rear control panel to **RECIRC** position, door **D1** (6) shuts the fresh air inlet port. Air inside the cabin is recirculated.

■ **FRESH**

By moving the air selection lever (16) to **FRESH** position, door **D1** opens the fresh air inlet port. Outside air comes into cabin.

2) Temperature control of outlet air is done with door D2.

■ **COOL**

By setting the temperature control dial (1) in control panel to **COOL** position, door **D2** (10) is moved to close water valve. The air flows to door **D3** (12) side without passing the heater core.

■ **WARM**

By moving the temperature lever to **WARM** position door **D2** is moved to open water valve. The air flows to door **D3** (12) side passing through the heater core.

3) Outlet air flow is controlled by door D3.

Moving the mode switch (2) opens and shuts door **D3** and establishes the air passage according to the lever position.

■ **DEF + FACE**

By moving the mode lever to **DEF + FACE** position, the door **D3** is moved to establish the air passages to outlets "**O1**" and "**O2**". Air comes out from both outlets.

■ **DEF**

Moving the mode lever to **DEF** position, door **D3** is moved to set up the air passage to outlet **O1**. Air comes out from outlet **O1**.

9Y1211109CAM0012US0

4. ELECTRICAL SYSTEM

[1] ELECTRICAL CIRCUIT

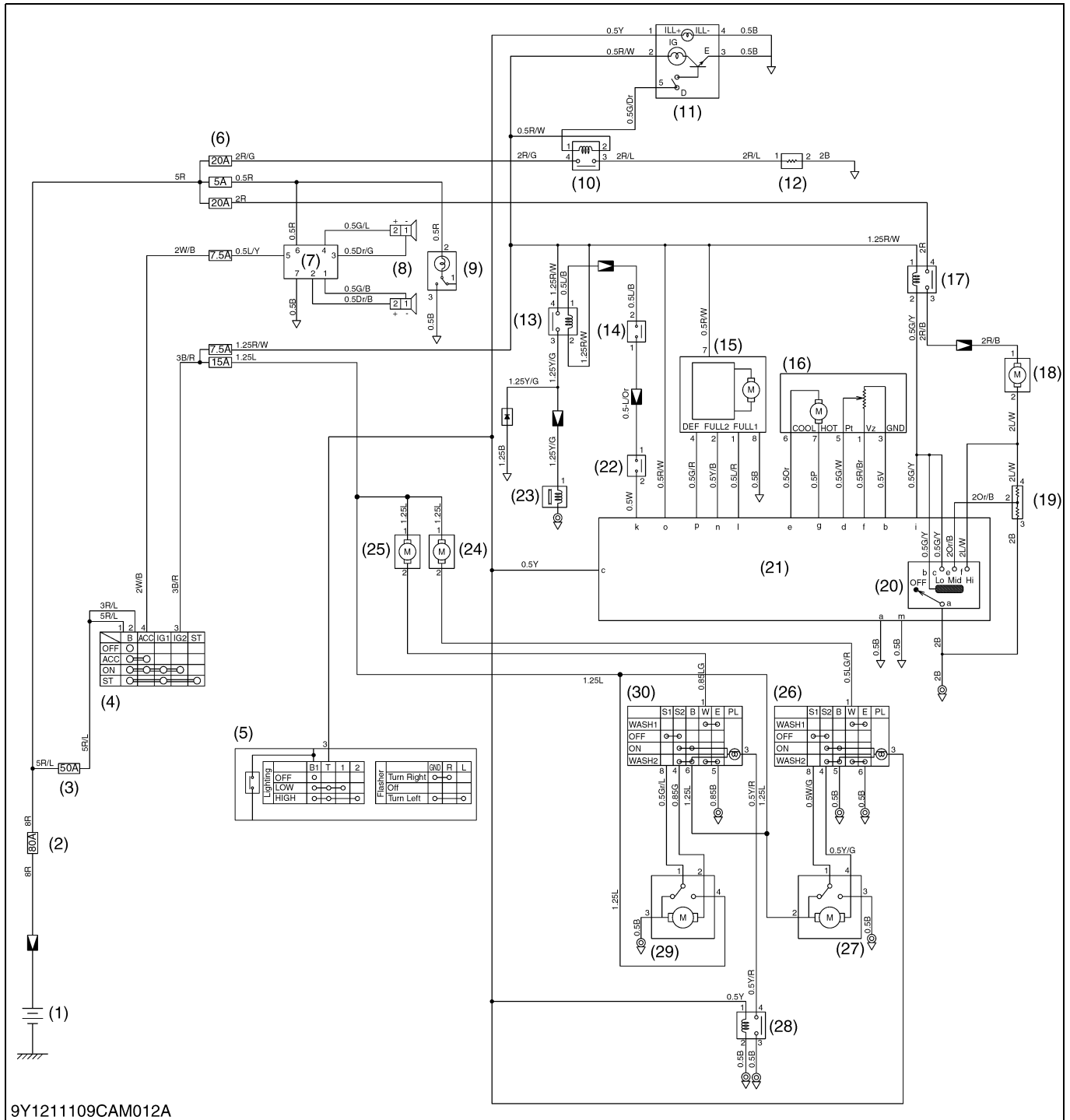

9Y1211109CAM012A

- | | | | |
|----------------------------------|-------------------------------|----------------------------|-------------------------|
| (1) Battery | (9) Room Lamp | (17) Blower Relay | (24) Rear Washer Motor |
| (2) Slow Blow Fuse (Main) | (10) Defogger Relay | (18) Blower Motor | (25) Front Washer Motor |
| (3) Slow Blow Fuse (Main Switch) | (11) Defogger Switch | (19) Blower Motor Resister | (26) Rear Wiper Switch |
| (4) Main Switch | (12) Defogger | (20) Blower Switch | (27) Rear Wiper Motor |
| (5) Combination Switch | (13) Compressor Relay | (21) A/C Unit | (28) Wiper Relay |
| (6) Fuse | (14) Pressure Switch | (22) Thermostat | (29) Front Wiper Motor |
| (7) Audio Unit | (15) Servo Motor Switch | (23) Compressor | (30) Front Wiper Switch |
| (8) Speaker | (16) Thermostatic Servo Motor | | |

9Y1211109CAM0013US0

[2] RELAY

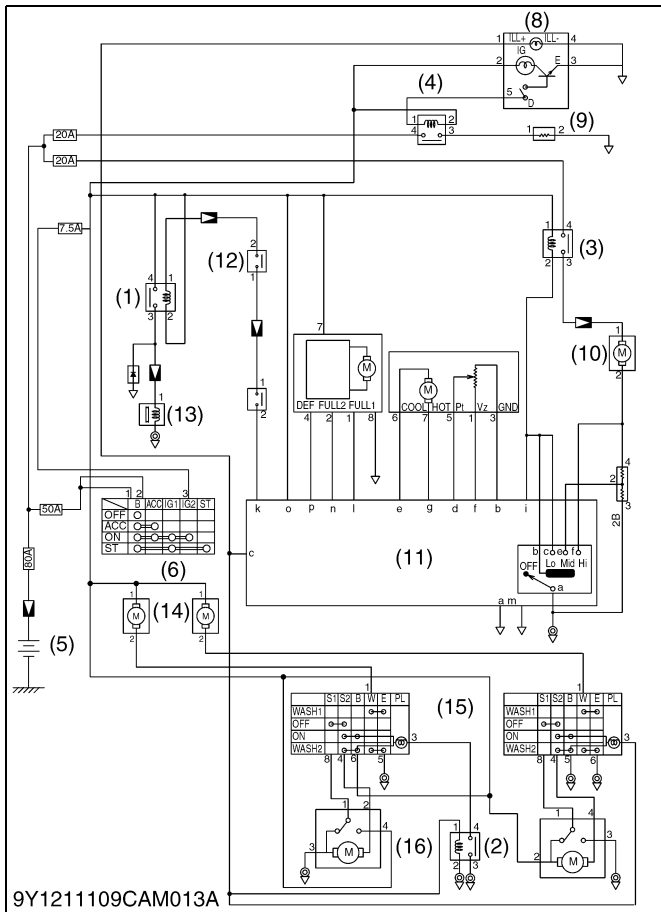
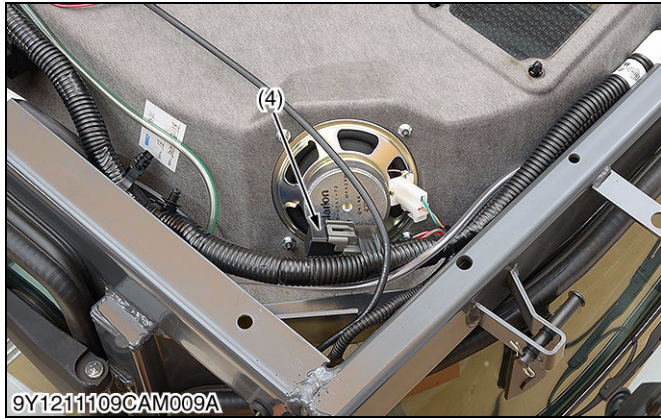
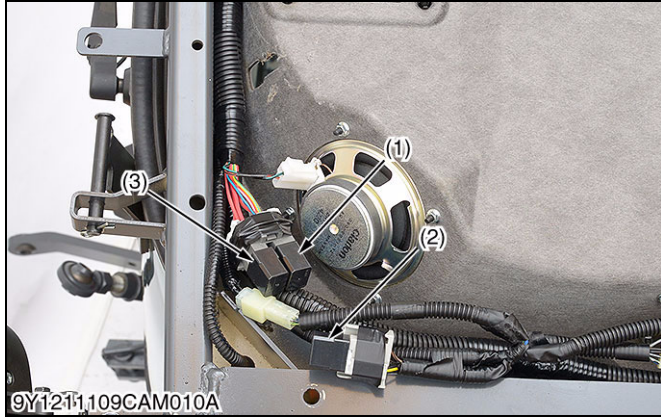

Remove the outer roof and the relays are visible at the ceiling rear of the cabin: blower relay (3) and compressor relay (1). When the blower fan is adjusted for the air flow rate, the blower relay (3) is activated by a signal from the fan switch on the control panel.

Among the air conditioner components, current flows to the blower motor (10) and magnetic clutch. If all of these current were to be passed through the main switch (6) and supplied, the current would be too large for the main switch (6) so that there will be danger or burning out the main switch contact. If the current were to be passed directly from the battery (5), forgetting to turn off the blower motor (10) could result in a discharged battery (5).

To protect against such trouble, relays have been provided. These relays have been made so that when current flows through its coil, the contact close to supply the power from the battery (5). By employing these relays, the current flowing through the main switch (6) has been decreased as only a small current is required to actuate the relay. Thus there will be no danger of burning out the switch contact, and when the main switch (6) is opened, the relay contact will open at the same time. This action stops the current flow in the air conditioner circuit so that there will also be no chance of the battery discharging.

- | | |
|------------------------|-------------------------|
| (1) Compressor Relay | (9) Defogger |
| (2) Wiper Relay | (10) Blower Motor |
| (3) Blower Relay | (11) A/C Unit |
| (4) Defogger Relay | (12) Pressure Switch |
| (5) Battery | (13) Compressor |
| (6) Main Switch | (14) Washer Tank Motor |
| (7) Combination Switch | (15) Wiper Motor Switch |
| (8) Defogger Switch | (16) Wiper Motor |

9Y1211109CAM0014US0

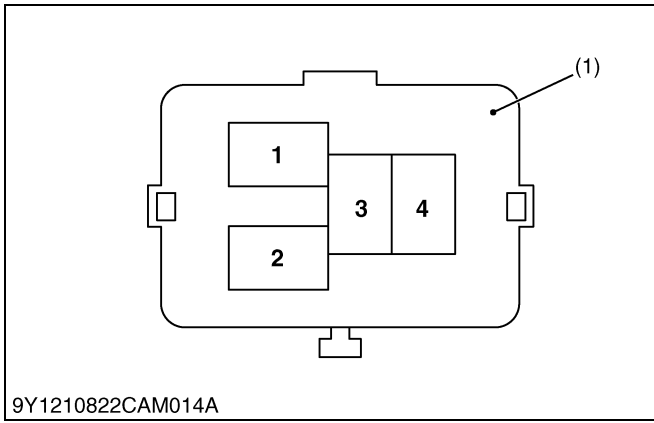

Color of wiring

Item	Terminal No.	Color of Wiring
Blower Relay	1	1.25 R/W
	2	0.5 GY
	3	2.0 R/B
	4	2.0 R
Compressor Relay	1	1.25 R/W
	2	0.5 L/B
	3	1.25 Y/G
	4	1.25 R/W
Front Wiper Relay	1	0.5 B
	2	0.5 Y
	3	0.5 B
	4	0.5 Y/R
Defogger Relay	1	0.5 R/W
	2	0.5 G/Or
	3	2.0 R/L
	4	2.0 R/G

(1) Connector (Wire Harness)

9Y1211109CAM0015US0

SERVICING

CONTENTS

1. TROUBLESHOOTING.....	10-S1
2. SERVICING SPECIFICATIONS.....	10-S5
3. TIGHTENING TORQUES.....	10-S6
4. PRECAUTIONS AT REPAIRING REFRIGERANT CYCLE.....	10-S7
[1] HANDLING OF SERVICE TOOLS.....	10-S9
(1) Manifold Gauge Set.....	10-S9
(2) Refrigerant Charging Hose.....	10-S10
(3) Vacuum Pump Adaptor.....	10-S11
(4) Electric Gas Leak Tester.....	10-S11
(5) Can Tap Valve.....	10-S11
(6) T-joint.....	10-S12
(7) R134a Refrigerant Recovery and Recycling Machine.....	10-S12
5. CHECKING AND CHARGING REFRIGERANT CYCLE.....	10-S13
[1] CHECKING WITH MANIFOLD GAUGE.....	10-S13
[2] DISCHARGING, EVACUATING AND CHARGING.....	10-S18
(1) Discharging the Refrigerant.....	10-S18
(2) Evacuating the System.....	10-S19
(3) Charging the Refrigerant.....	10-S20
(4) Checking Charge Refrigerant Amount.....	10-S22
6. CHECKING, DISASSEMBLING AND SERVICING.....	10-S23
[1] CHECKING, DISASSEMBLING AND SERVICING.....	10-S23
(1) Compressor.....	10-S23
(2) Control Panel (Blower Switch, A/C Switch, Mode Control Dial and Temperature Control Dial).....	10-S24
(3) Blower Resistor.....	10-S26
(4) Blower Motor.....	10-S27
(5) Temperature Motor.....	10-S27
(6) Mode Motor.....	10-S28
(7) Relay.....	10-S28
(8) Pressure Switch.....	10-S29
(9) Wiper Switch.....	10-S30
(10)Wiper Motor.....	10-S31
(11)Defogger.....	10-S31
[2] DISASSEMBLING AND ASSEMBLING.....	10-S32
(1) Separating Cabin from Tractor Body.....	10-S32
(2) Removing Compressor Assembly.....	10-S44
(3) Removing Air Conditioner Unit.....	10-S46
(4) Removing Air Conditioner Pipes.....	10-S48
(5) Removing Heater Hoses.....	10-S50
(6) Cabin Windshields.....	10-S51
(7) Wiper Motor.....	10-S54
[3] SERVICING.....	10-S55

1. TROUBLESHOOTING

COMPRESSOR

Symptom	Probable Cause and Checking Procedure	Solution	Reference Page
Noisy (Compressor ON)	1. Bearing of compressor is worn or damaged.	Replace compressor.	10-S44
	2. Valves in compressor is damaged.	Replace compressor.	10-S44
	3. Belt slipping	Adjust or replace belt.	10-S23
	4. Compressor bracket mounting screws is loosen.	Tighten screws.	10-S44
Noisy (Compressor OFF)	1. Blower is damaged	Repair or replace blower.	10-S27
	2. Bearings of magnetic clutch, idle pulley or crank pulley is worn or damaged.	Replace compressor.	10-S44

AIR CONDITIONING SYSTEM

Symptom	Probable Cause and Checking Procedure	Solution	Reference Page
Does Not Cool (No Air Flow)	1. Fuse is blown.	Replace fuse.	G-39
	2. A/C compressor relay is damaged.	Replace relay.	10-S28
	3. A/C blower relay is damaged.	Replace relay.	10-S28
	4. A/C blower motor is damaged.	Replace blower motor.	10-S27
	5. A/C blower switch is damaged.	Replace blower switch.	10-S24
	6. Wiring harness is disconnected or improperly connected.	Repair wiring harness.	–
Does Not Cool (Compressor Does Not Rotate)	1. Fuse is blown.	Replace fuse.	G-39
	2. Magnetic clutch damaged.	Repair or replace compressor.	10-S44
	3. A/C switch is damaged.	Replace A/C switch.	10-S24
	4. Pressure switch is damaged.	Replace pressure switch.	10-S29
	5. Belt slipping	Adjust or replace belt.	10-S23
Does Not Cool (Others)	1. Insufficient refrigerant	Check with manifold gauge.	10-S13
	2. Expansion valve is damaged.	Replace expansion valve.	10-M7
	3. Compressor is damaged.	Replace compressor.	10-S44
Insufficient Cooling (Insufficient Air Flow)	1. Air filter is clogged.	Clean or replace air filter.	G-32, G-32
	2. Evaporator is frosted.	Clean evaporator.	10-S48
	3. A/C blower motor is damaged.	Replace A/C blower motor.	10-S27
	4. A/C blower resistor is damaged.	Replace A/C blower resistor.	10-S27

Symptom	Probable Cause and Checking Procedure	Solution	Reference Page
Insufficient Cooling (Many Bubbles in Sight Glass)	1. Insufficient refrigerant	Check with manifold gauge.	10-S13
	2. Gas leaking from some place in refrigerating cycle	Repair and charge refrigerant.	–
	3. Air mixed in.	Check with manifold gauge.	10-S13
Insufficient Cooling (No Bubbles in Sight Glass)	1. Too much refrigerant	Check with manifold gauge.	10-S13
Insufficient Cooling (Compressor Does Not Rotate Properly)	1. Belt slipping	Adjust or replace belt.	10-S23
	2. Magnetic clutch is damaged.	Repair or replace compressor.	10-S44
	3. Compressor is damaged.	Replace compressor.	10-S44
Insufficient Cooling (Others)	1. Temperature motor is damaged.	Replace temperature motor.	10-S27
	2. Water valve is damaged.	Replace water valve.	10-M1
	3. Condenser fin clogged with dust	Clean condenser fin.	G-32
	4. Expansion valve is damaged.	Replace expansion valve.	10-M7
Insufficient Heating	1. Water valve is damaged.	Replace water valve.	10-M1
	2. Temperature motor is damaged.	Check and repair temperature motor.	10-S27
	3. Insufficient coolant	Fill coolant.	G-35
Too Low Air Flow Rate (Blower Motor Does Not Run)	1. Blower switch is damaged.	Check and repair blower switch.	10-S24
	2. A/C compressor relay is damaged.	Replace compressor relay.	10-S28
	3. Brush in poor contact.	Replace compressor.	10-S44
	4. Fuse is blown.	Replace fuse.	G-39
	5. Wrong wiring or loose connections.	Check and repair wiring.	–
Too Low Air Flow Rate (Flow Rate Does Not Change in 3 Steps)	1. Blower resistor is damaged.	Replace blower resistor.	10-S26
	2. Relay is damaged.	Replace relay.	10-S28
	3. Blower switch is damaged.	Replace blower switch.	10-S24
Too Low Air Flow Rate (Others)	1. Blower is not tightened enough.	Check and repair blower.	10-S27
	2. Blower is deformed.	Replace blower.	10-S48
	3. Blower in contact with casing.	Check and repair blower.	10-S48
	4. Obstacle at or near suction port.	Check and repair suction port.	G-32, G-32
	5. Evaporator is frosted.	Clean or replace evaporator.	10-S48
	6. Filter is clogged.	Clean or replace filter.	G-32, G-32
	7. Blow duct is clogged or missing.	Check and repair blow duct.	10-S48

Symptom	Probable Cause and Checking Procedure	Solution	Reference Page
Insufficient Cooling (Compressor Magnetic Clutch Does Not Work)	1. Low battery voltage	Charge battery.	G-29
	2. Rotor in contact with stator	Replace rotor.	10-S45
	3. Wrong wiring loose connections	Check and repair wiring.	–
	4. Relay is damaged.	Replace relay.	10-S28
	5. Coil shortage	Replace coil.	10-S45
	6. Ground malfunction	Check and repair wiring.	–
Insufficient Cooling (Hi-pressure Level is Too High)	1. Refrigerant overcharged	Check with manifold gauge.	10-S13
	2. Condenser is clogged with dust and dirt	Clean condenser.	G-32
	3. Air mixed	Check with manifold gauge.	10-S13
Insufficient Cooling (Hi-pressure Level is Too Low)	1. Refrigerant too short	Check with manifold gauge.	10-S13
	2. Compressor discharge valve is damaged	Replace compressor.	10-S44
	3. Compressor gasket is damaged	Replace compressor.	10-S44
	4. Low-pressure pipe in trouble. (Cracked or clogged)	Replace low-pressure pipe.	10-S49
Insufficient Cooling (Low-pressure Level is Too High)	1. Refrigerant overcharged	Check with manifold gauge	10-S13
	2. Expansion valve too open	Replace expansion valve.	10-M7
Insufficient Cooling (Low-pressure Level is Too Low)	1. Refrigerant too short	Check with manifold gauge.	10-S13
	2. Evaporator frosted	Clean or replace evaporator.	10-S48
	3. Low-pressure pipe in trouble (Cracked or clogged)	Replace low-pressure pipe.	10-S49
	4. Expansion valve is clogged	Replace expansion valve.	10-M7
Insufficient Cooling (Both Hi-pressure and Low-pressure Level is Too High)	1. Refrigerant overcharged	Check with manifold gauge.	10-S13
Insufficient Cooling (Both Hi-pressure and Low-pressure Level is Too Low)	1. Refrigerant too short	Check with manifold gauge.	10-S13
Temperature Cannot be Controlled (Temperature Motor and / or Temperature Control Dial Malfunction)	1. Temperature motor damaged	Replace temperature motor.	10-S27
	2. Temperature control dial is damaged	Replace heater panel assembly.	10-S24
	3. Wiring harness connector is disconnected	Repair or replace wiring harness.	–
Temperature Cannot be Controlled (Water Valve Does Not Open Properly)	1. Cable wrongly set	Repair cable.	–
	2. Cable is disconnected	Repair cable.	–

Symptom	Probable Cause and Checking Procedure	Solution	Reference Page
Temperature Cannot be Controlled (Mode Motor and / or Mode Switch Malfunction)	1. Mode motor is damaged	Replace mode motor assembly.	10-S28
	2. Mode switch is damaged	Replace mode switch assembly.	10-S24
	3. Wiring harness controller is disconnected	Repair or replace wiring harness.	–
Temperature Cannot be Controlled (Heater Hoses Laid is Bad)	1. Heater hose is caught	Repair heater hose.	10-S51
	2. Heater hose is twisted or bent	Repair or replace heater hose.	10-S51

WINDSHIELD WIPER

Symptom	Probable Cause and Checking Procedure	Solution	Reference Page
Windshield Wiper Does Not Operate	1. Fuse is blown (Short-circuit, burnt component inside motor or other part for operation)	Correct cause and replace fuse.	G-39
	2. Wiper motor is damaged (Broken armature, worn motor brush or seized motor shaft)	Replace wiper motor.	10-S31
	3. Wiper switch is damaged	Replace wiper switch.	10-S30
	4. Foreign material interrupts movement of link mechanism	Repair linkage.	–
	5. Wiper arm is seized or rusted	Lubricate or replace wiper arm.	–
Windshield Wiper Operating Speed Is Too Low	1. Wiper motor is damaged (Short-circuit of motor armature, worn motor brush or seized motor shaft)	Replace wiper motor.	10-S31
	2. Low battery voltage	Recharge or replace battery.	G-29
	3. Humming occurs on motor in arm operating cycle due to be seized arm shaft	Lubricate or replace wiper motor.	10-S54
	4. Wiper switch contact improper	Replace wiper switch.	10-S30
Windshield Wiper Does Not Stop Correctly	1. Wiper motor is damaged (Contaminated auto-return contacts or improper contact due to foreign matter)	Replace wiper motor.	10-S54

9Y1211109CAS0001US0

2. SERVICING SPECIFICATIONS

Item		Factory Specification	Allowable Limit
Kinds of refrigerant	Charge Amount	R134a 630 to 730 g 1.39 to 1.60 lbs	–
Refrigerating Cycle (Refrigerating Cycle is Normal Operating)	Pressure (LO Pressure Side)	0.15 to 0.20 MPa 1.5 to 2.0 kgf/cm ² 21 to 28 psi	–
	Pressure (HI Pressure Side)	1.27 to 1.66 MPa 13 to 17 kgf/cm ² 185 to 242 psi	–
A/C Compressor Magnetic Clutch	Air-gap	0.30 to 0.65 mm 0.012 to 0.025 in.	–
Air Conditioner Drive Belt	Tension	14 to 16 mm (0.56 to 0.62 in.) deflection at 98 N (10 kgf, 22 lbf) of force	–
Pressure Switch (Dual Type) (When pressure switch is turned OFF)	Setting Pressure (LO Pressure Side)	Less than approx. 0.196 MPa 2.0 kgf/cm ² 28.4 psi	–
	Setting Pressure (HI Pressure Side)	More than approx. 3.14 MPa 32 kgf/cm ² 455 psi	–
Number of Wiper Arm Swing Frequency	At No Load	33 to 43 times/min.	–

9Y1211109CAS0002US0

3. TIGHTENING TORQUES

Tightening torques of screws, bolts and nuts on the table below are especially specified.
(For general use screws, bolts and nuts: Refer to "5. TIGHTENING TORQUES" on page G-10.)

Item	N·m	kgf·m	lbf·ft
Rear wheel mounting nut	196.1 to 225.6	20.0 to 23.0	145 to 166
Steering wheel mounting nut	48.1 to 55.9	4.9 to 5.7	35.4 to 41.2
Delivery hose R.H. retaining nut	24.5 to 29.4	2.5 to 3.0	18.1 to 21.7
Delivery hose L.H. retaining nut	24.5 to 29.4	2.5 to 3.0	18.1 to 21.7
Return hose retaining nut	34.3 to 44.1	3.5 to 4.5	25.3 to 32.5
Delivery hose joint screw	45.1 to 53.0	4.60 to 5.40	33.3 to 39.0
Hydraulic hose PB, P and T retaining nuts	196.1 to 225.6	20.0 to 23.0	145 to 166
Outer roof mounting screw	3.5 to 4.0	0.36 to 0.40	2.6 to 2.9
Cabin mounting bolt and nut	124 to 147	12.6 to 15.0	91.1 to 108
High pressure pipe and low pressure pipe mounting screw	7.90 to 11.8	0.806 to 1.20	5.83 to 8.70
Compressor mounting screws	24.5 to 29.4	2.50 to 2.99	18.1 to 21.6
Magnetic clutch mounting screw	15 to 21	1.5 to 2.1	11 to 15
A/C unit mounting screw (M6)	3.9 to 6.8	0.40 to 0.70	2.9 to 5.0
A/C unit mounting screw (M8)	9.81 to 11.6	1.00 to 1.19	7.24 to 8.60
Joint mounting screw	7.85 to 11.8	0.801 to 1.20	5.79 to 8.70
Low pressure hose mounting screw (compressor side)	7.85 to 11.8	0.801 to 1.20	5.79 to 8.70
High pressure hose 1 mounting screw (compressor side)	7.85 to 11.8	0.801 to 1.20	5.79 to 8.70
High pressure hose 1 mounting screw (condenser side)	3.9 to 6.8	0.40 to 0.69	2.9 to 5.0
High pressure hose 2 mounting screw (receiver side)	3.9 to 6.8	0.40 to 0.69	2.9 to 5.0
High pressure hose 2 mounting screw (condenser side)	3.9 to 6.8	0.40 to 0.69	2.9 to 5.0
Wiper arm mounting nut	7.9 to 9.8	0.80 to 1.0	5.8 to 7.2
Wiper motor mounting screw	3.4 to 6.4	0.35 to 0.65	2.5 to 4.7

9Y1211109CAS0003US0

4. PRECAUTIONS AT REPAIRING REFRIGERANT CYCLE

When checking or repairing the air conditioning system, the following precautions and rules must be observed. And it is of first importance that no other personnel than a well-trained serviceman should be allowed to handle the refrigerant.



CAUTION

- Since direct contact of the liquid refrigerant with your skin will cause frostbite, always be careful when handling the refrigerant. Always wear goggles to protect your eyes when working around the system.
- The refrigerant service container has a safe strength. However, if handled incorrectly, it will explode. Therefore, always follow the instructions on the label. In particular, never heat the refrigerant container above 40 °C (104 °F) or drop it from a high height.
- Do not steam clean on the system, especially condenser since excessively high pressure will build up in the system, resulting in explosion of the system.
- If you improperly connect the hose between the service valve of compressor and gauge manifold, or incorrectly handle the valves, the refrigerant service container or charging hose will explode. When connecting the hose or handling the valve, be sure to check the high pressure side or low pressure side.
- In case the refrigerant is charged while the compressor is operated, do not open the high pressure valve of the gauge manifold.
- Be careful of the toxicity of the gas. The gas is harmless and nontoxic in its original state, however it produces a toxic substance when it comes in contact with high temperature parts and decomposes.
- Do not heat the service can unless necessary. When it has to be heated, use warm water of 40 °C (104 °F) or lower. Do not heat using boiling water.

■ IMPORTANT

- If the refrigerant, O-rings, etc. for R12 are used in the R134a air conditioner system, problems such as refrigerant leakage or cloudiness in the sight glass may occur. Therefore, in order to prevent charging of refrigerant or erroneous connections, the shapes of the piping joint as well as the shapes of the service valve and the service tools have been changed.
- Always keep the working place clean and dry and free from dirt and dust. Wipe off water from the line fittings with a clean cloth before disconnecting.
- Use only for R134a refrigerant service tool.
- Use for R134a refrigerant recovery and recycling machine when discharging the refrigerant.
- Before attaching the charging hose to the can tap valve of the refrigerant container, check each packing for clogging.
- When disconnecting the charging hose from the charging valve of compressor and receiver, remove it as quick as possible so that gas leakage can be minimized.
- Be sure to charge the specified amount of refrigerant, but not excessively. Over-charging of the refrigerant in particular may cause insufficient cooling, etc..
- Since the charging hose can be connected to can tap valve by hand, do not use a pliers for tightening it.
- Keep refrigerant containers in a cool and dark place avoiding such place which are subject to strong sunlight or high temperature.
- R134a compressor oil absorbs moisture easily, so that be sure to seal after disconnecting the each parts.
- Do not use old-type refrigerant R12 or compressor oil for old-type refrigerant.
- When replacing the condenser, evaporator and receiver, etc., fill the compressor oil to compressor according to the table below.

(To be continued)

(Continued)**(Refrigerant)**

Kinds of refrigerant (Charge amount)	Factory specification	R134a 630 to 730 g 1.39 to 1.60 lbs
---	-----------------------	---

(Compressor Oil)

Quantity (Total)	Brand Name
110 to 120 cc 0.116 to 0.126 U.S.qts 0.0968 to 0.105 Imp.qts	ND-OIL 8 <PAG* oil>

*PAG: Polyalkyleneglycol (Synthetic oil)

(Reference)

Replacing Parts	Fill Quantity	Brand Name
Condenser	20 cc 0.021 U.S.qts 0.018 Imp.qts	ND-OIL 8 <PAG* oil>
Evaporator	10 cc 0.011 U.S.qts 0.0088 Imp.qts	
Receiver	10 cc 0.011 U.S.qts 0.0088 Imp.qts	
Hose	10 cc 0.011 U.S.qts 0.0088 Imp.qts	

*PAG: Polyalkyleneglycol (Synthetic oil)

9Y1211109CAS0004US0

[1] HANDLING OF SERVICE TOOLS

(1) Manifold Gauge Set

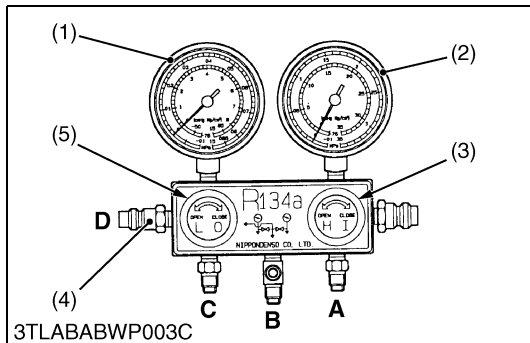

The hand valves on the manifold gauge set are used to open and close the valve. The hand valve inscribed **LO** is for the low pressure side valve (5) and **HI** is for the high pressure side valve (3). By opening or closing the high and low pressure hand valves, the following circuits are established.

- (1) **LO** Pressure Gauge
- (2) **HI** Pressure Gauge
- (3) **HI** Pressure Side Valve
- (4) Schrader Valve
- (5) **LO** Pressure Side Valve

9Y1211109CAS0005US0

When LO Pressure Side Valve and HI Pressure Side Valve are Closed

Two circuits are established.
 Port **C** → **LO** pressure gauge (1)
 Port **A** → **HI** pressure gauge (2)

■ **NOTE**

- Schrader valve "D" must be opened.

9Y1211109CAS0006US0

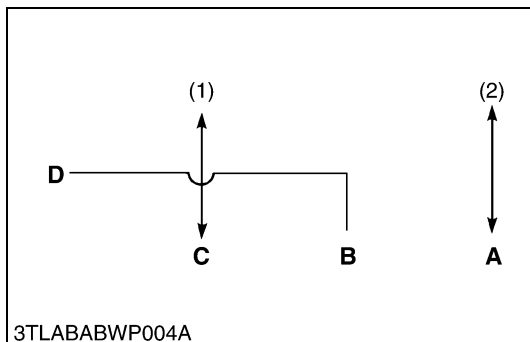

When LO Valve is Opened and HI Valve is Closed

Two circuits are established.
 Port **C** → **LO** pressure gauge (1)
 Port **C** → Port **B**
 Port **C** → Port **D**
 Port **A** → **HI** pressure gauge (2)

■ **NOTE**

- Schrader valve "D" must be opened.

9Y1211109CAS0007US0

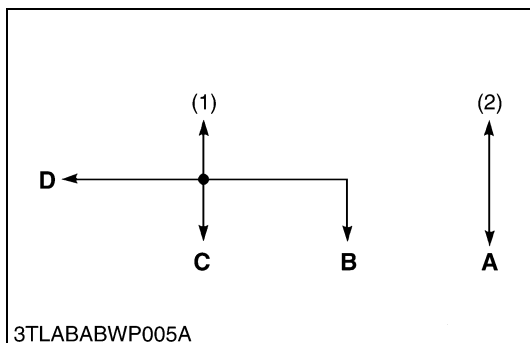

When LO Valve is Closed and HI Valve is Opened

Two circuits are established.
 Port **C** → **LO** pressure gauge (1)
 Port **C** → Port **B**
 Port **C** → Port **D** (Schrader valve must be opened)
 Port **A** → **HI** pressure gauge (2)

■ **NOTE**

- Schrader valve "D" must be opened.

9Y1211109CAS0008US0

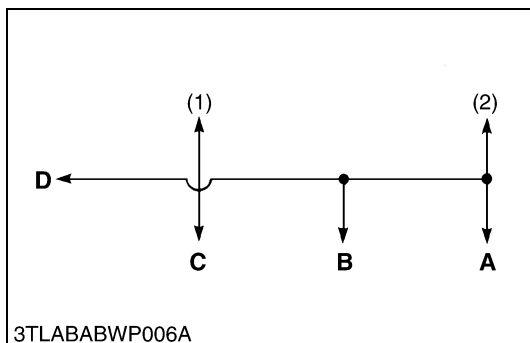

When LO and HI Valve are Opened

Circuits are established.
 Port **A** → **HI** pressure gauge (2)
 Port **A** → **LO** pressure gauge (1)
 Port **A** → Port **B**
 Port **A** → Port **C**
 Port **A** → Port **D** (Schrader valve must be opened)

■ **NOTE**

- Schrader valve "D" must be opened.

9Y1211109CAS0009US0

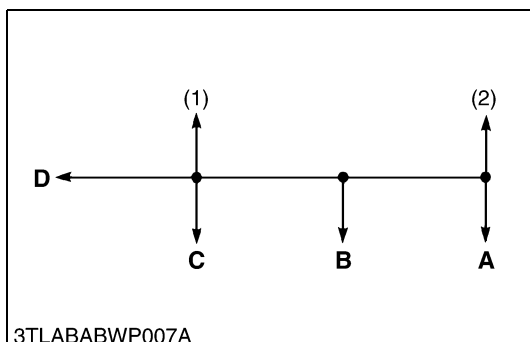

(2) Refrigerant Charging Hose

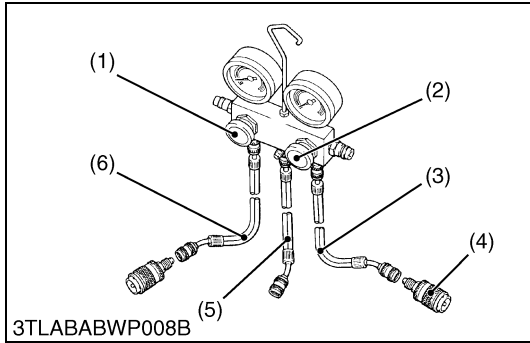

The charging hoses are classified into three colors. Each charging hose must be handled as follows:

- The air conditioner manufacture recommends that the blue hose (6) is used for the **LO** pressure side (suction side), the green hose (5) for refrigeration side (center connecting port) and the red hose (3) for **HI** pressure side (discharged side).

(When connecting)

- Push the quick disconnect adaptor (4) into the charging valve, and push on part "A" until a click is heard.

■ NOTE

- When connecting, push carefully so the pipe does not bend.
- When connecting the quick disconnect connector, should the sleeve (7) move before the quick link connector can be connected to the charging valve, move the quick sleeve to its original position and try again.
- When some refrigerant remains in the charging hose at the time of connections, it may be difficult to connect the quick link connector. In this case, perform the operation after removing any residual pressure in the hose. (Remove the residual pressure by pushing the pusher (8).)

(When reassembling)

- While holding on to part "A" of the quick disconnect adaptor, slide part "B" up.

■ NOTE

- After removing the adaptor, ensure to cap the quick disconnect adaptor service valve.

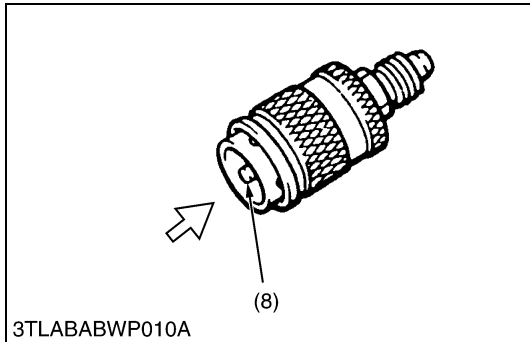
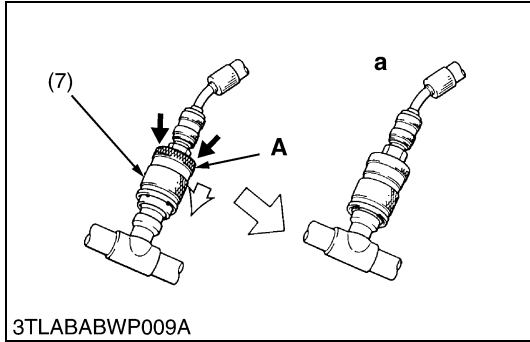

- | | |
|------------------------------|-----------------|
| (1) LO Pressure Side Valve | (7) Sleeve |
| (2) HI Pressure Side Valve | (8) Pusher |
| (3) Red Hose | (9) Sleeve |
| (4) Quick Disconnect Adaptor | |
| (5) Green Hose | a: CLICK |
| (6) Blue Hose | |

9Y1211109CAS0010US0

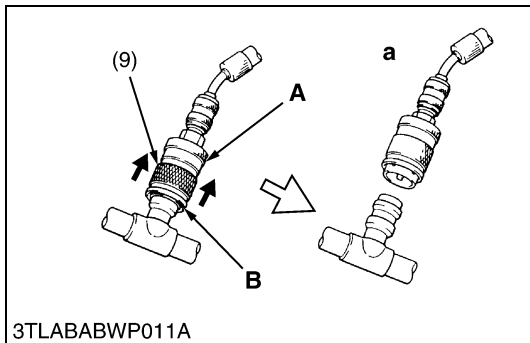

(3) Vacuum Pump Adaptor

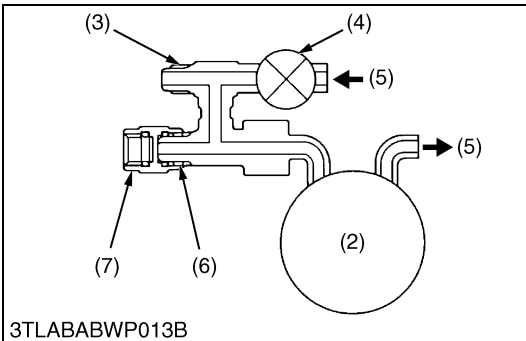
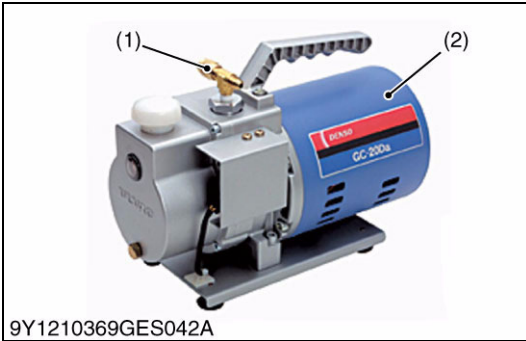

Objective of the Vacuum Pump Adaptor

1. After vacuum has been created in the air conditioning cycle, when the vacuum pump is stopped, since there is vacuum in hoses within the gauge manifold, the vacuum pump oil flows back into the charging hose. If the refrigerant is refilled with the system still in this state, the vacuum pump oil left in the charging hose enters the air conditioner cycle together with the refrigerant. Vacuum pump adaptor with a solenoid valve is used to prevent this back-flow of oil from the vacuum pump. The role of the solenoid valve is that when the current passes through the solenoid valve, the valve closes to keep out the outside air and allow the vacuum to build up, but when the current stops, the valve opens to allow in air and end the vacuum.
2. Attaching this adaptor to the R12 vacuum pump currently being used allows the pump to be used with both R134a and R12.

- | | |
|-------------------------|---------------|
| (1) Vacuum Pump Adaptor | (5) Air |
| (2) Vacuum Pump | (6) For R12 |
| (3) For R134a | (7) Blind Cap |
| (4) Magnetic Valve | |

9Y1211109CAS0011US0

(4) Electric Gas Leak Tester

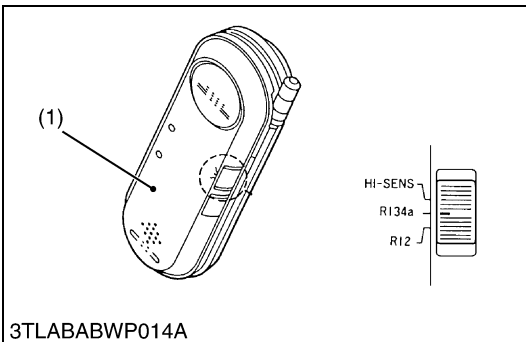

The current R12 gas leak tester has poor sensitivity for R134a and cannot be used. Therefore, a new electric gas leak tester with greater sensitivity has been designed and can be used with both R134a and R12.

(Reference)

- Leak tester with halide torch
- Since the reaction with chlorine within the refrigerant is used to detect gas leaks, R134a, which contains no chlorine, cannot be detected.

- (1) Electric Gas Leak Tester

9Y1211109CAS0012US0

(5) Can Tap Valve

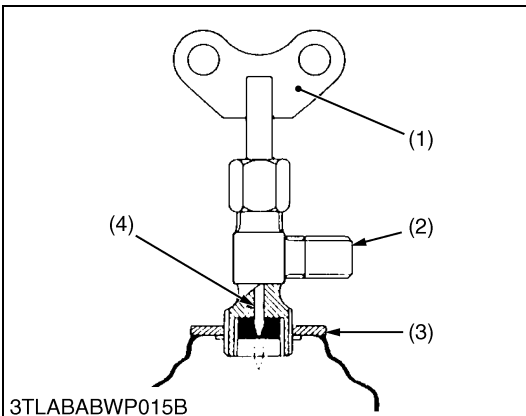

The can tap valve that is used to charge the refrigerant into the air conditioning system, should be used as follows:

1. Before putting the can tap valve on the refrigerant container, turn the handle (1) counterclockwise till the valve needle is fully retracted.
2. Turn the plate nut (disc) (3) counterclockwise till it reaches its highest position, then screw down the can tap valve into the sealed tap.
3. Turn the place nut clockwise fully, and fix the center charging hose to the valve.
4. Tighten the place nut firmly by hand.
5. Turn the handle (1) clockwise, thus making a hole in the sealed tap.
6. To charge the refrigerant into the system, turn the handle (1) counterclockwise. To stop charging, turn it clockwise.

- | | |
|----------------------|------------|
| (1) Butterfly Handle | (3) Disc |
| (2) Connection | (4) Needle |

9Y1211109CAS0013US0

(6) T-joint

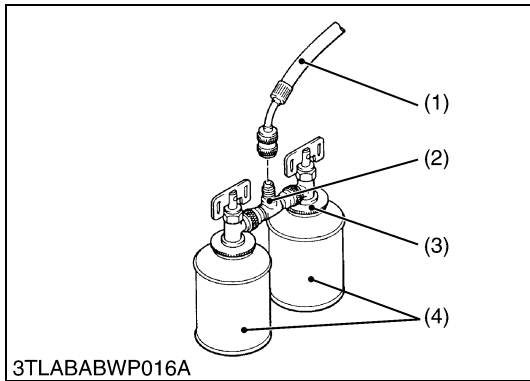

T-joint (2) is used to increase efficiency of gas charging using two refrigerant containers (4) at a time.

1. Install two refrigerant container service valves to T-joint (2) sides and connect the charging hose (1) to it.

- | | |
|---------------------------|---------------------------|
| (1) Charging Hose (Green) | (3) Can Tap Valve |
| (2) T-joint | (4) Refrigerant Container |

9Y1211109CAS0014US0

(7) R134a Refrigerant Recovery and Recycling Machine

When there is necessity of discharging the refrigerant on repairing the tractor, it should use recovery and recycling machine. (Do not release the refrigerant into the atmosphere.)

■ IMPORTANT

- Use only R134a refrigerant recovery and recycling machine, eliminate mixing R134a equipment, refrigerant and refrigerant oils with R12 systems to prevent compressor damage.

9Y1211109CAS0015US0

5. CHECKING AND CHARGING REFRIGERANT CYCLE

[1] CHECKING WITH MANIFOLD GAUGE

■ IMPORTANT

- The gauge indications described in the following testing are those taken under the same condition, so it should be noted that the gauge readings will differ somewhat with the ambient conditions.

Condition

- Ambient temperature: 30 to 35 °C (86 to 95 °F)
- Engine speed: Approx. 1500 min⁻¹ (rpm)
- Temperature control lever: Maximum cooling position
- Air-Conditioner switch: **ON**
- Blower switch: **HI** position

9Y1211109CAS0016US0

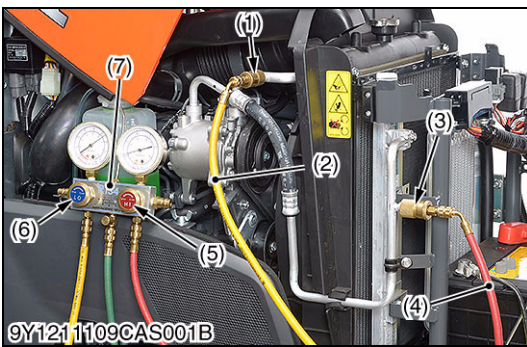

Manifold Gauge Connecting and Test Preparation

1. Close the manifold gauge **HI** and **LO** pressure side valve (5), (6) tightly.
2. Connect the charging hose (4) (red) to the **HI** pressure side charging valve (3) and connect the charging hose (2) (yellow) to the **LO** pressure side charging valve (1).

■ NOTE

- Be sure to drive out the air in the charging hoses at the manifold gauge connection end by utilizing the refrigerant pressure in the refrigerating cycle.
3. Start the engine and set at approx. 1500 min⁻¹ (rpm).
 4. Turn on the A/C switch and set the temperature control lever to **maximum cooling** position.
 5. Set the blower switch to **HI** position.

- | | |
|--|-----------------------------------|
| (1) LO Pressure Side Charging Valve | (5) HI Pressure Side Valve |
| (2) Charging Hose (Yellow) | (6) LO Pressure Side Valve |
| (3) HI Pressure Side Charging Valve | (7) Manifold Gauge |
| (4) Charging Hose (Red) | |

9Y1211109CAS0017US0

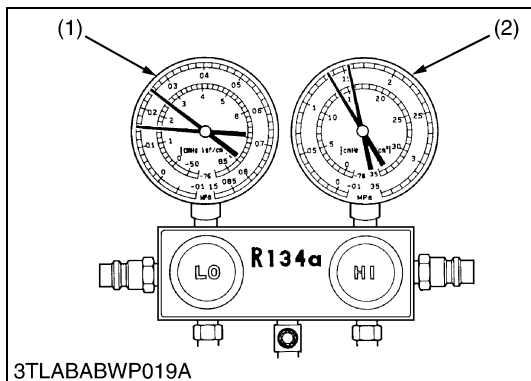

Normal Operating

If the refrigerating cycle is operating normally, the reading at the **LO** pressure side (1) should be generally by around 0.15 to 0.2 MPa (1.5 to 2.0 kgf/cm², 21 to 28 psi) and that at the **HI** pressure side (2) around 1.27 to 1.66 MPa (13 to 17 kgf/cm², 185 to 242 psi).

Gas pressure	Factory specification	Low pressure side	0.15 to 0.20 MPa 1.5 to 2.0 kgf/cm ² 21 to 28 psi
		High pressure side	1.27 to 1.66 MPa 13 to 17 kgf/cm ² 185 to 242 psi

- | | |
|-----------------------------|-----------------------------|
| (1) LO Pressure Side | (2) HI Pressure Side |
|-----------------------------|-----------------------------|

9Y1211109CAS0018US0

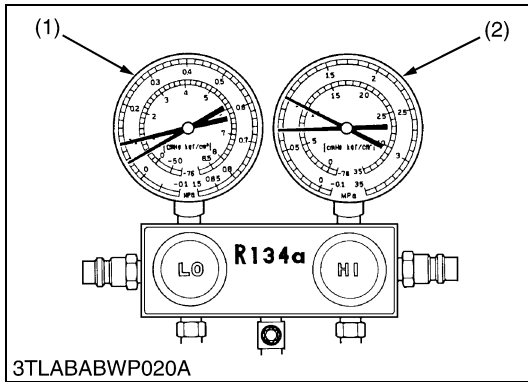

Insufficient Refrigerant

- Symptoms seen in refrigerating cycle
 - Both **LO** and **HI** pressure side (1), (2) pressures too low.
 - LO** pressure side (1)
0.05 to 0.10 MPa (0.5 to 1.0 kgf/cm², 7.1 to 14.2 psi)
 - HI** pressure side (2)
0.69 to 0.98 MPa (7 to 10 kgf/cm², 99.6 to 142.2 psi)
 - Bubbles seen in sight glass.
 - Air discharged from air conditioner slightly cold.
- Probable cause
 - Gas leaking from some place in refrigerant cycle.
- Solution
 - Check for leakage with electric gas leak tester. (See page 10-S11) and repair.
 - Recharge refrigerant to the proper level. (See page 10-S21.)

(1) **LO** Pressure Side(2) **HI** Pressure Side

9Y1211109CAS0019US0

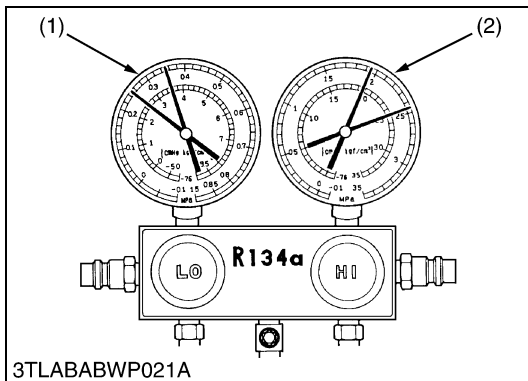

Excessive Refrigerant or Insufficient Condenser Cooling

- Symptoms seen in refrigerating cycle
 - Both **LO** and **HI** pressure side (1), (2) pressures too high.
 - LO** pressure side (1)
0.20 to 0.35 MPa (2.0 to 3.5 kgf/cm², 28.4 to 49.8 psi)
 - HI** pressure side (2)
1.96 to 2.45 MPa (20 to 25 kgf/cm², 284.5 to 355.6 psi)
- Probable cause
 - Overcharging refrigerant into cycle.
 - Condenser cooling faulty.
- Solution
 - Clean condenser. (See page G-32.)
 - Adjust air conditioner belt to proper tension. (See page G-31.)
 - If the above two items are in normal condition, check refrigerant quantity. (See page G-40.)

■ NOTE

- If excessive refrigerant is to be discharged, loosen manifold gauge **LO** pressure side valve and vent out slowly.

(1) **LO** Pressure Side(2) **HI** Pressure Side

9Y1211109CAS0020US0

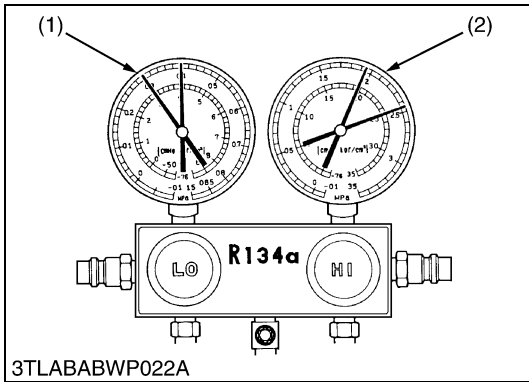

Air Entered in the Cycle

1. Symptoms seen in refrigerating cycle
 - Both **LO** and **HI** pressure side (1), (2) pressures too high.
 - LO** pressure side (1)
0.20 to 0.35 MPa (2.0 to 3.5 kgf/cm², 28.4 to 49.8 psi)
 - HI** pressure side (2)
1.96 to 2.45 MPa (20 to 25 kgf/cm², 284.5 to 355.6 psi)
 - **LO** pressure side (1) piping not cold when touched.
2. Probable cause
 - Air entered in refrigerating cycle.
3. Solution
 - Replace receiver.
 - Check compressor oil contamination and quantity.
 - Evacuate and recharge new refrigerant. (See page 10-S22.)

■ **NOTE**

- **The above cycle can be seen when the cycle is charged without evacuation.**

(1) **LO** Pressure Side (2) **HI** Pressure Side

9Y1211109CAS0021US0

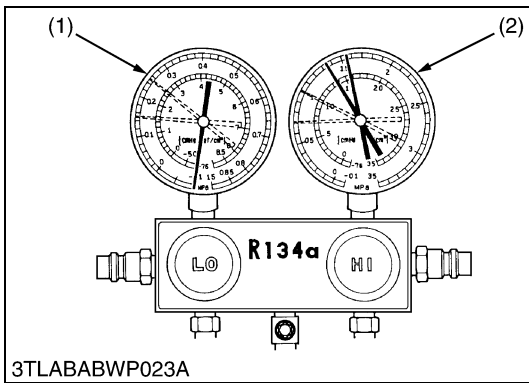

Moisture Entered in the Cycle

1. Symptoms seen in refrigerating cycle
 - The air conditioner operates normally at the beginning, but over time, **LO** pressure side (1) pressure is **vacuum** and **HI** pressure side (2) is low pressure.
 - LO** pressure side (1)
Vacuum
 - HI** pressure side (2)
0.69 to 0.98 MPa (7 to 10 kgf/cm², 99.6 to 142.2 psi)
2. Probable cause
 - The moisture in the refrigerating cycle freezes in the expansion valve orifice and causes temporary blocking. After a time, the ice melts and condition returns to normal.
3. Solution
 - Replace receiver.
 - Remove moisture in cycle by means of repeated evacuation. (See page 10-S18.)
 - Recharge new refrigerant to the proper level. (See page 10-S20.)

(1) **LO** Pressure Side (2) **HI** Pressure Side

9Y1211109CAS0022US0

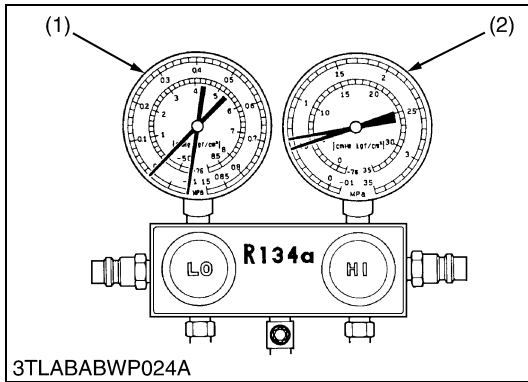

Refrigerant Fails to Circulate

- Symptoms seen in refrigerating cycle
 - LO** pressure side (1) pressure is vacuum and, **HI** pressure side (2) is low pressure.
LO pressure side (1)
 Vacuum
HI pressure side (2)
 0.49 to 0.59 MPa (5 to 6 kgf/cm², 71.2 to 85.3 psi)
- Probable cause
 - Refrigerant flow obstructed by moisture or dirt in the refrigerating cycle freezing or sticking on the expansion valve orifice.
- Solution

Allow to stand for same time and then resume operation to decide whether the plugging is due to moisture or dirt.

 - If caused by moisture, correct by referring to instructions in previous.
 - If caused by dirt, remove the expansion valve and blow out the dirt with compressed air.
 - If unable to remove the dirt, replace the expansion valve. Replace the receiver. Evacuate and charge in proper amount of new refrigerant. (See page 10-S20.)
 - If caused by gas leakage in heat sensitizing tube, replace the expansion valve.

(1) **LO** Pressure Side(2) **HI** Pressure Side

9Y1211109CAS0023US0

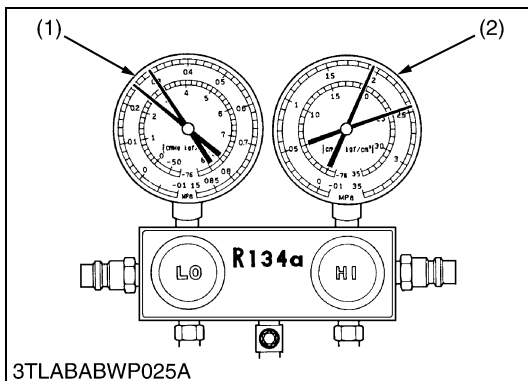

Expansion Valve Opens Too Far or Improper Installation of Heat Sensitizing Tube

- Symptoms seen in refrigerating cycle
 - Both **LO** and **HI** pressure side (1), (2) pressures too high.
LO pressure side (1)
 0.29 to 0.39 MPa (3 to 4 kgf/cm², 42.7 to 56.9 psi)
HI pressure side (2)
 1.96 to 2.45 MPa (20 to 25 kgf/cm², 284.5 to 355.6 psi)
 - Frost or heavy dew on low pressure side piping.
- Probable cause
 - Expansion valve trouble or heat sensitizing tube improperly installed.
 - Flow adjustment not properly done.
- Solution
 - Check installed condition of heat sensitizing tube.
 - If installation of heat sensitizing tube is correct, replace the expansion valve.

(1) **LO** Pressure Side(2) **HI** Pressure Side

9Y1211109CAS0024US0

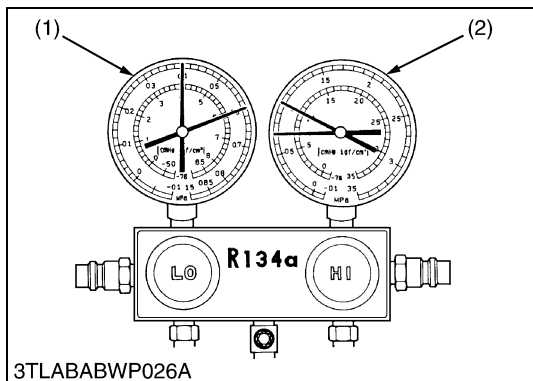

Faulty Compression of Compressor

1. Symptoms seen in refrigerating cycle
 - **LO** pressure side (1)
0.39 to 0.59 MPa (4 to 6 kgf/cm², 56.9 to 85.3 psi)
 - **HI** pressure side (2)
0.69 to 0.98 MPa (7 to 10 kgf/cm², 99.6 to 142.2 psi)
2. Probable cause
 - Leak in compressor.
3. Solution
 - Replace compressor. (See page 10-S44.)

■ NOTE

- **Manifold gauge indications (left side figure) at faulty compressing by compressor.**

(1) **LO** Pressure Side

(2) **HI** Pressure Side

9Y1211109CAS0025US0

[2] DISCHARGING, EVACUATING AND CHARGING

■ IMPORTANT

- When discharging, evacuating or charging the refrigerating system, be sure to observe the "4. PRECAUTIONS AT REPAIRING REFRIGERANT CYCLE" on page 10-S7.

9Y1211109CAS0026US0

(1) Discharging the Refrigerant

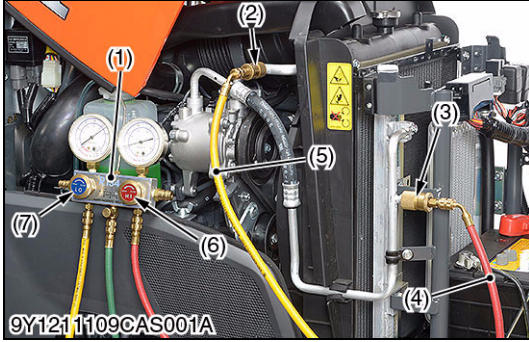

Prepare for the R134a refrigerant recovery and recycling machine.

1. Connect low pressure side hose (yellow) (5) from the recovery and recycling machine to **LO** pressure side charging valve (2). Connect high pressure side hose (red) (4) to **HI** pressure side charging valve (3).
2. Follow the manufacturers instructions and discharge the system.

■ IMPORTANT

- Use only R134a refrigerant recovery and recycling machine. Eliminate mixing R134a equipment, refrigerant, and refrigerant oils with R12 system to prevent compressor damage.



CAUTION

- Protect fingers and eyes with cloth against frostbite by refrigerant when disconnecting the hose to the charging valve.

- | | |
|--|-----------------------------------|
| (1) Manifold Gauge | (5) Charging Hose (Yellow) |
| (2) LO Pressure Side Charging Valve | (6) HI Pressure Side Valve |
| (3) HI Pressure Side Charging Valve | (7) LO Pressure Side Valve |
| (4) Charging Hose (Red) | |

9Y1211109CAS0027US0

(2) Evacuating the System

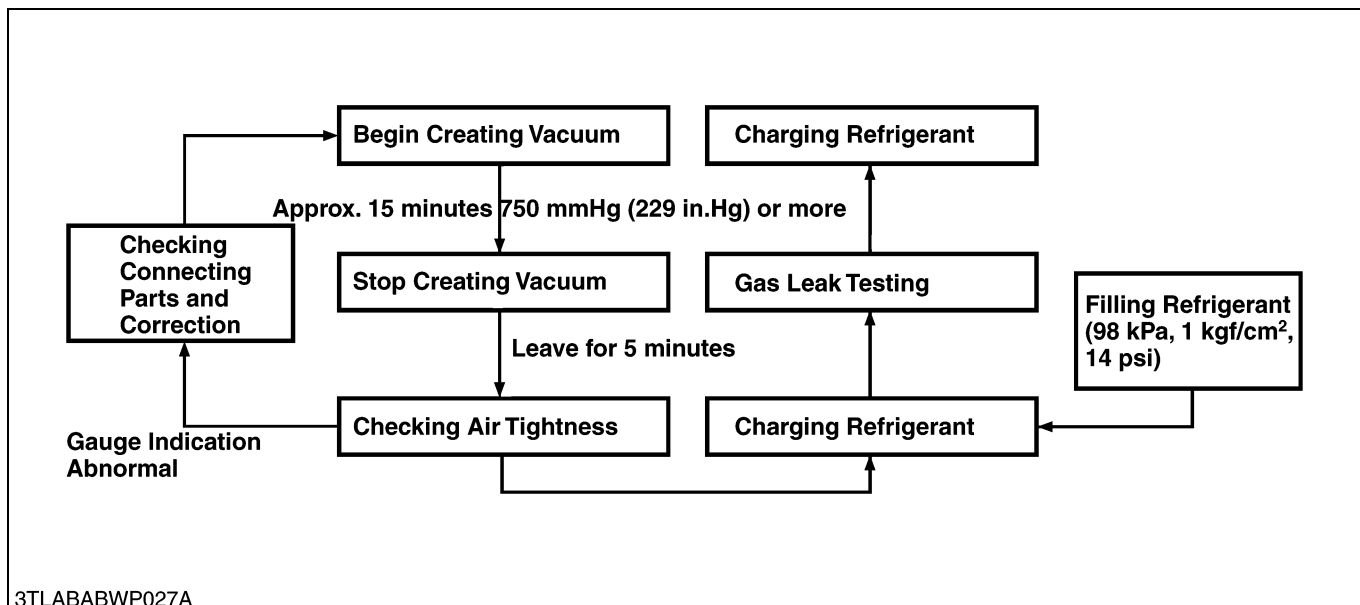

1. Discharge refrigerant from the system by R134a refrigerant recovery and recycling machine. (See page 10-S12.)
2. Connect the charging hose (red) to the **HI** pressure side charging valve and connect the charging hose (blue) to the **LO** pressure side charging valve.
3. Connect the center charging hose (green) to a vacuum pump inlet.
4. Open both valves of manifold gauge fully. Then run the vacuum pump to evacuate the refrigerant cycle. (For approx. 15 minutes.)
5. When **LO** pressure gauge reading is more than 750 mmHg (299 in.Hg), stop the vacuum pump and close both valves of manifold gauge fully.
6. Wait for over 5 minutes with the **HI** and **LO** pressure side valves of gauge manifold closed, and then check that gauge indicator does not return to 0.
7. If the gauge indicator is going to approach to 0, check whether there is a leaking point and repair if it is, and then evacuate it again.

9Y1211109CAS0028US0

(3) Charging the Refrigerant

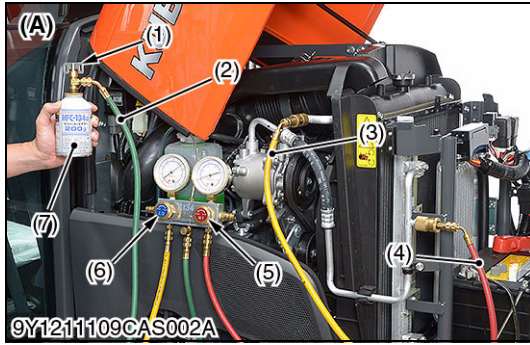

Charging an Empty System (Liquid)

This procedure is for charging an empty system through the **HI** pressure side with the refrigerant in the liquid state.

⚠ CAUTION

- Never run the engine when charging the system through the **HI** pressure side.
- Do not open the **LO** pressure valve when refrigerant R134a is being charged in the liquid state (refrigerant container is set upside-down).

■ IMPORTANT

- After charging the refrigerant in the liquid state with approx. 500 g (1.1 lbs) through the **HI** pressure side, be sure to recharge the refrigerant in the vapor state to specified amount through the **LO** pressure side.
1. Close the **HI** and **LO** pressure side valves (5) and (6) of manifold gauge after the system is evacuated completely.
 2. Connect the center charging hose (green) (2) to the can tap valve (1) fitting, and then loosen the center charging hose (green) (2) at the center fitting of manifold gauge until hiss can be heard.
Allow the air to escape for few seconds and tighten the nut.
 3. Open the **HI** pressure side valve (5) fully, and keep the container upside-down to charge the refrigerant in the liquid state from the **HI** pressure side.
 4. Charge the refrigerant in the liquid state with approx. 500 g (1.1 lbs) from the **HI** pressure side.

■ NOTE

- If **LO** pressure gauge does not show a reading, the system is clogged and must be repaired.
5. Close the **HI** pressure side valve (5) of manifold gauge and can tap valve of refrigerant container.

- | | |
|-----------------------------------|---------------------------------------|
| (1) Can Tap Valve | (A) Refrigerant Container "Upside" |
| (2) Charging Hose (Green) | (B) Refrigerant Container "Down Side" |
| (3) Charging Hose (Yellow) | |
| (4) Charging Hose (Red) | |
| (5) HI Pressure Side Valve | |
| (6) LO Pressure Side Valve | |
| (7) Refrigerant Container (R134a) | |

9Y1211109CAS0029US0

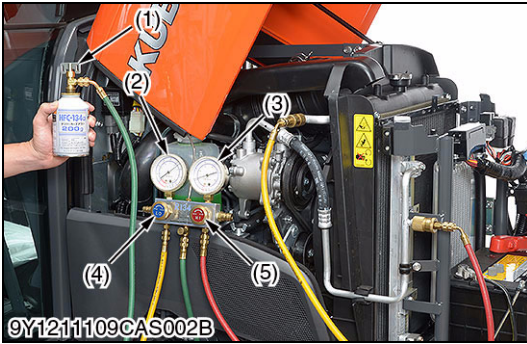

Charging an Empty or Partially Charged System (Vapor)

This procedure is to charge the system through the **LO** pressure side with refrigerant in the vapor state. When the refrigerant container is set right side up, refrigerant will enter the system as a vapor.



CAUTION

- **Never open the HI pressure side valve of manifold gauge while the engine is running.**

NOTE

- **Do not turn the refrigerant container upside-down when charging the system by running the engine.**
- **Put refrigerant container into a pan of warm water (maximum temperature 40 °C (104 °F)) to keep the vapor pressure in the container slightly higher than vapor pressure in the system.**

1. Check that the **HI** pressure side valve (4) is closed.
2. Start the engine and set an approx. 1500 min⁻¹ (rpm).
3. Turn on the A/C switch.
Set the temperature control lever to **maximum cooling** position and the blower switch to **HI** position.
4. Open the **LO** pressure side valve (5) of manifold gauge and the can tap valve (1) on refrigerant container and charge the refrigerant until air bubbles in the sight glass of the receiver vanish.
5. After charging the specified amount of refrigerant into the system, close the **LO** pressure side valve (5) of manifold gauge and can tap valve (1), then stop the engine.
6. Check for gas leak with an electric gas leak tester. (See page 10-S11.)

(Reference)

- Specified amount of refrigerant (total)
770 to 870 g (1.70 to 1.90 lbs) [Refrigerant R134a]
- Manifold gauge indication at fully charged system (at ambient temperature: 30 °C (86 °F))

HI pressure side

1.27 to 1.66 MPa (13 to 17 kgf/cm², 185 to 242 psi)

LO pressure side

0.15 to 0.20 MPa (1.5 to 2.0 kgf/cm², 21 to 28 psi)

- | | |
|------------------------------|-----------------------------------|
| (1) Can Tap Valve | (4) HI Pressure Side Valve |
| (2) LO Pressure Gauge | (5) LO Pressure Side Valve |
| (3) HI Pressure Gauge | |

9Y1211109CAS0030US0

(4) Checking Charge Refrigerant Amount

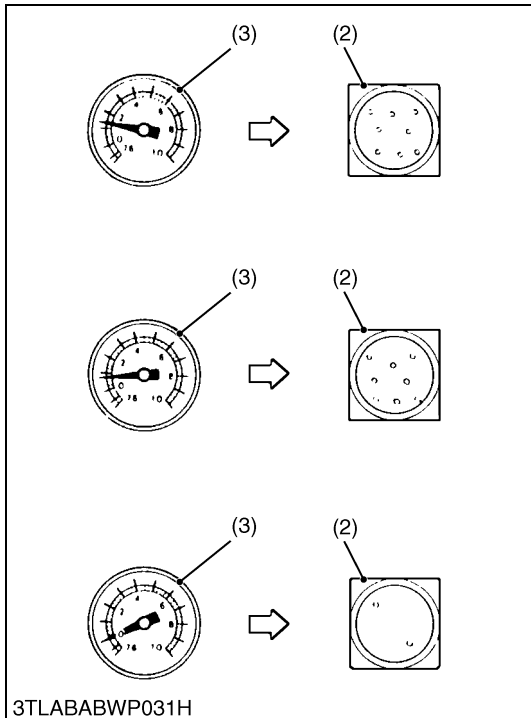
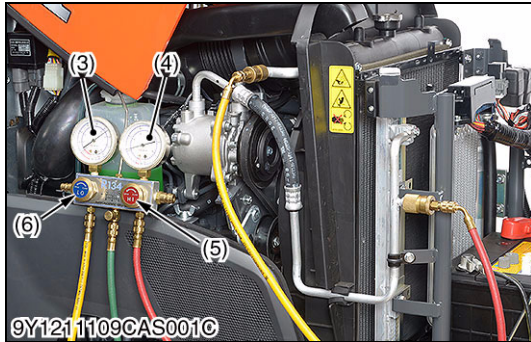

After charging the refrigerant, check for amount of charging refrigerant as follows.

■ **NOTE**

- The pressure on the following checking is the gauge indications at ambient temperature 30 °C (86 °F), so it should be noted that the pressure will differ some what with the ambient temperature.

1. Disconnect the **1P** connector (1) of magnetic clutch.
2. Start the engine and set a approx. 1500 min⁻¹ (rpm).
3. Connect the **1P** connector of magnetic clutch to battery directly, and then set the blower switch to **HI** position.
4. Leave the system for approx. 5 minutes until the refrigerant cycle becomes stable, keeping pressure on the **HI** pressure side from 1.3 to 1.6 MPa (13 to 17 kgf/cm², 190 to 240 psi).
5. When the refrigerant cycle is stabilizer, turn off the blower switch and let the compressor alone to run. Then pressure on the **LO** pressure side gradually drops. At this time, if pressure on the **HI** pressure side is kept from 1.3 to 1.6 MPa (13 to 17 kgf/cm², 190 to 240 psi), air bubbles which pass through the sight glass (2) becomes as stated below depending on refrigerant charged amount.

■ **Insufficient refrigerant charge**

Air bubbles pass continuously the sight glass when pressure on the **LO** pressure side is over 98 kPa (1.0 kgf/cm², 14 psi). In this case, charge the refrigerant from the **LO** pressure side.

■ **Properly refrigerant charge**

Air bubbles pass through the sight glass continuously when pressure on the **LO** pressure side is within 59 to 98 kPa (0.60 to 1.0 kgf/cm², 8.6 to 14 psi).

If the charge refrigerant amount is proper, no air bubble is observed on the sight glass at pressure on the **LO** pressure side over 98 kPa (1.0 kgf/cm², 14 psi) when the blower switch is turned on. When the blower switch is turned off, bubbles pass through the sight glass in case pressure on the **LO** pressure side is within 59 to 98 kPa (0.60 to 1.0 kgf/cm², 8.6 to 14 psi).

■ **Excessive refrigerant charge**

Air bubbles pass through the sight glass time to time or no air bubble is observed when pressure on the **LO** pressure side is under 60 kPa (0.6 kgf/cm², 9 psi).

In this case, discharge excessive refrigerant gradually from the **LO** pressure side.

- | | |
|------------------------------|-----------------------------------|
| (1) 1P Connector | (4) HI Pressure Gauge |
| (2) Sight Glass | (5) HI Pressure Side Valve |
| (3) LO Pressure Gauge | (6) LO Pressure Side Valve |

9Y1211109CAS0031US0

6. CHECKING, DISASSEMBLING AND SERVICING

[1] CHECKING, DISASSEMBLING AND SERVICING

(1) Compressor

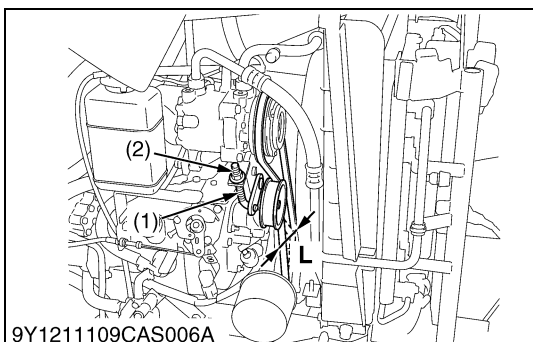
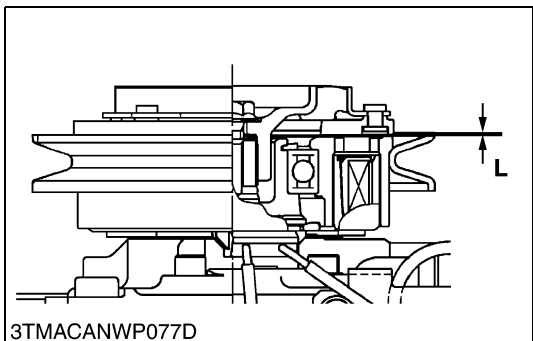

Operation of Magnetic Clutch

1. Turn off the A/C switch after starting the engine.
2. Check whether abrasion or abnormal noise is heard when only the magnetic clutch pulley is running.
3. Check that the magnetic clutch (1) does not slip when the A/C switch and blower switch are turned "ON" (when the air conditioner is in operation).
4. If anything abnormal is found, repair or replace.

(1) Magnetic Clutch

9Y1211109CAS0032US0

Stator Coil

1. Measure the resistance of the stator coil with an ohmmeter across the 1P connector (1) of magnetic clutch and compressor body.
2. If the measurement is not within the factory specifications, replace the stator coil.

Stator coil resistance	Factory specification	3.0 to 4.0 Ω
------------------------	-----------------------	--------------

(1) 1P Connector

9Y1211109CAS0033US0

Air Gap

1. Check the air gap with feeler gauge.
2. If the measurement is not within the factory specifications, adjust it. (See page 10-S55.)

Air gap "L"	Factory specification	0.30 to 0.65 mm 0.012 to 0.025 in.
-------------	-----------------------	---------------------------------------

L: Air Gap

9Y1211109CAS0034US0

Adjusting Air Conditioner Belt Tension

⚠ CAUTION

- Be sure to stop the engine before checking air conditioner belt tension.

1. Stop the engine and remove the key.
2. Apply 98 N (10 kgf, 22 lbf) pressure to the belt between the pulleys.
3. If tension is incorrect, adjust the belt tension.
4. If belt is damaged, replace it.

Air conditioner belt tension	Factory specification	A deflection of between 14 to 16 mm (0.56 to 0.62 in.) when the belt is pressed in the middle of the span
------------------------------	-----------------------	---

(1) Adjusting Bolt
(2) Nut

L: Deflection

9Y1211109CAS0035US0

(2) Control Panel (Blower Switch, A/C Switch, Mode Control Dial and Temperature Control Dial)

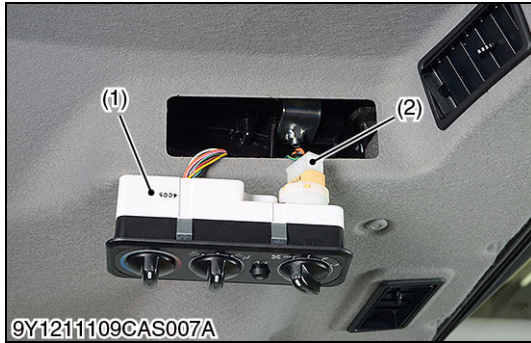

Blower Switch Connector Voltage

1. Disconnect the **6P** connector (2) from blower switch.
2. Turn the main switch to **"ON"** position.
3. Measure the voltage with a voltmeter across the connector terminal **a** and terminal **b**.
4. If the voltage differs from the battery voltage, the wiring harness, A/C relay, fuse or main switch is faulty.

Voltage	Terminal a – Terminal b	Approx. battery voltage
---------	-------------------------	-------------------------

- (1) Control Panel
- (2) 6P Connector

(A) 6P Connector (Wire Harness Side)

9Y1211109CAS0036US0

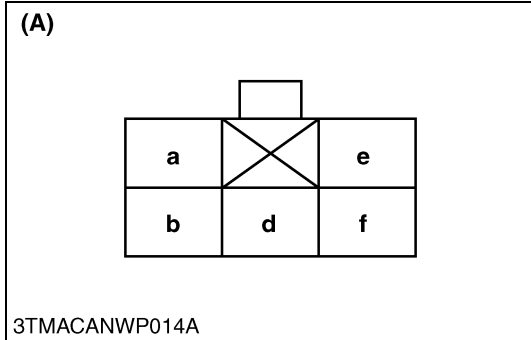

Blower Switch Test

1. Check the continuity through the switch with an ohmmeter.
2. If the continuity specified below are not indicated, the switch is faulty.

Position		Terminal					
		a	b	c	e	f	d
A/C blower switch	OFF						
	1 (Low)	●	●	●			
	2 (Medium)	●			●		
	3 (High)	●	●			●	

9Y1210822CAS016US

(A) 6P Connector (Blower Switch Side)

9Y1211109CAS0037US0

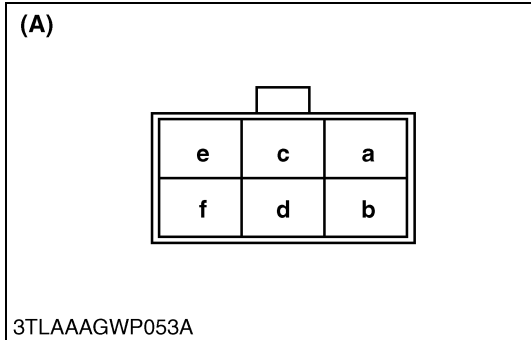

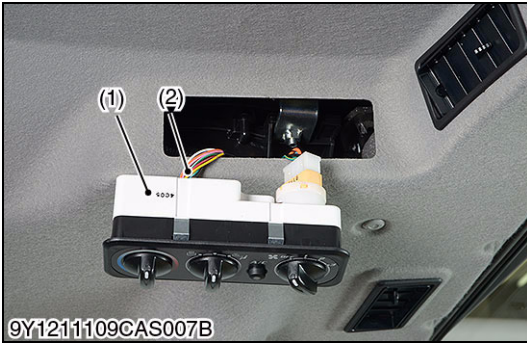

9Y1211109CAS007B

Connector Voltage

1. Disconnect the **16P** connector (2) from control panel switch.
2. Turn the main switch to **"ON"** position.
3. Measure the voltage with a voltmeter across the terminal **o** and terminal **a**.
4. If the voltage differs from the battery voltage, the wiring harness, A/C relay or fuse is faulty.

Voltage	Terminal o – Terminal a	Approx. battery voltage
---------	---------------------------------------	-------------------------

- (1) Control Panel (3) **16P** Connector (Wire Harness Side)
 (2) **16P** Connector (Switch Side)

9Y1211109CAS0038US0

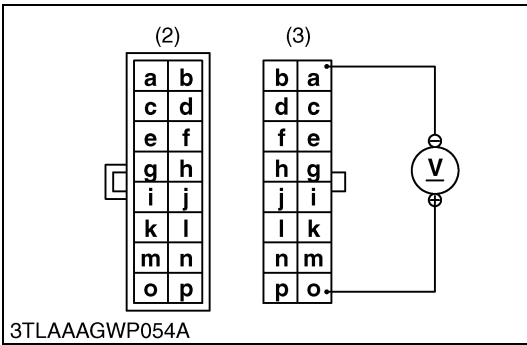

3TLAAAGWP054A

A/C Switch Checking

1. Measure the voltage with a voltmeter across the terminal **k** and chassis.
2. Turn the main switch to **"ON"** position.
3. Turn the blower switch to **"ON"** position.
4. Press the air conditioner switch to set it to **"OFF"** position (indicator: OFF), and then measure a voltage using a circuit tester.
5. Press the air conditioner switch to set it at **"ON"** position (indicator: ON), and then measure a voltage using a circuit tester.
6. If a measured voltage does not comply with the values in the table below, the control panel, wiring harness or fuse is faulty.

Voltage	Terminal k – Chassis	A/C switch at ON	Approx. battery voltage
		A/C switch at OFF	Approx. 1 V

- (1) **16P** Connector (Switch Side) (2) **16P** Connector (Wire Harness Side)

9Y1211109CAS0039US0

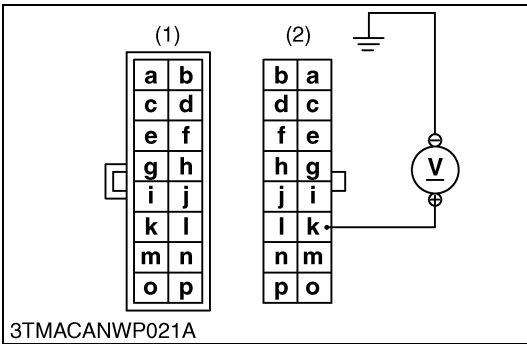

3TMACANWP021A

Mode Control Dial Checking

1. Disconnect the **16P** connector from control panel switch.
2. Check the continuity through the switch with an ohmmeter.
3. If the continuity specified below is not indicated, the switch is faulty.

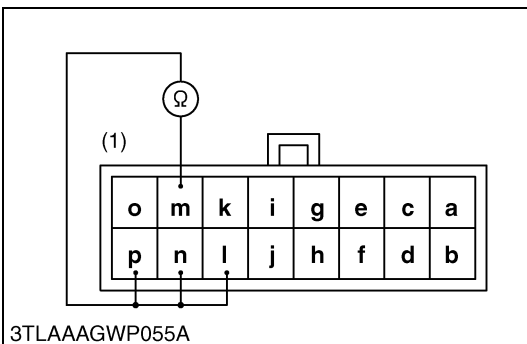

3TLAAAGWP055A

Position		Terminal			
		l	n	p	m
Mode switch	FRONT	●			●
	FULL		●		●
	DEF			●	●

9Y1210822CAS017US

- (1) **16P** Connector (Switch Side)

9Y1211109CAS0040US0

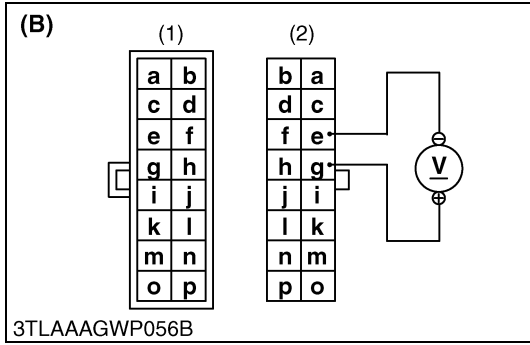
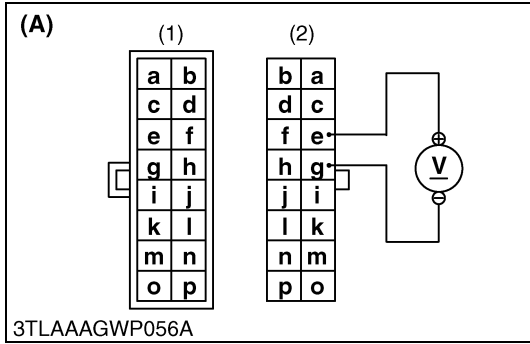

Temperature Control Dial Checking

1. Turn the temperature control dial counterclockwise till it stops (at "COOL" position).
2. Measure the voltage with a voltmeter across the terminal **b** and terminal **d**. Make the following measurement with the terminals connected.
3. Turn the main switch to "ON" position.
4. Check that an output voltage is approximately 10 V when turning the temperature control dial clockwise till it stops ("WARM" position).
5. Turn the main switch back to "OFF" position.
6. Turn the temperature control dial clockwise till it stops ("WARM" position).
7. Measure the voltage with a voltmeter across the terminal **d** and terminal **b**. Make the following measurement with the terminals connected.
8. Turn the main switch to "ON" position.
9. Check that an output voltage is approximately 10 V, when turning the temperature control dial counterclockwise till it stops ("COOL" position).
10. If an output voltage differs from approximately 10 V, the control panel, wiring harness or fuse is faulty.

- (1) 16P Connector (Switch Side)
 (2) 16P Connector (Wire Harness Side)

- (A) "COOL" position to "WARM" position
 (B) "WARM" position to "COOL" position

9Y1211109CAS0041US0

(3) Blower Resistor

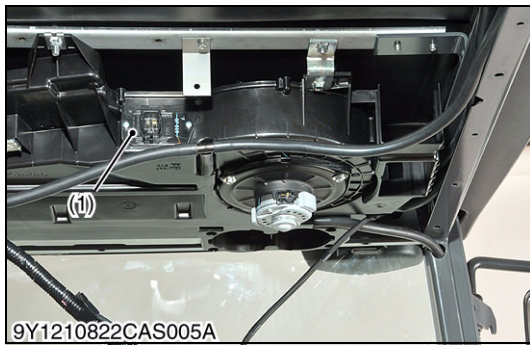

A/C Blower Resistor

1. Remove the inner roof.
2. Disconnect the 4P connector for A/C blower resistor (1).
3. Measure the resistance with an ohmmeter across the **R1** terminal and **E** terminal, and across the **R2** terminal and **E** terminal.
4. If the factory specifications are not indicated, A/C blower resistor is faulty.

Resistance	Factory specification	R1 terminal – E terminal	Approx. 0.56 Ω
		R2 terminal – E terminal	Approx. 1.56 Ω

- (1) A/C Blower Resistor

9Y1211109CAS0042US0

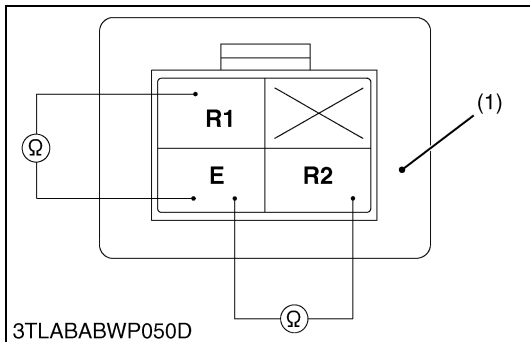

(4) Blower Motor

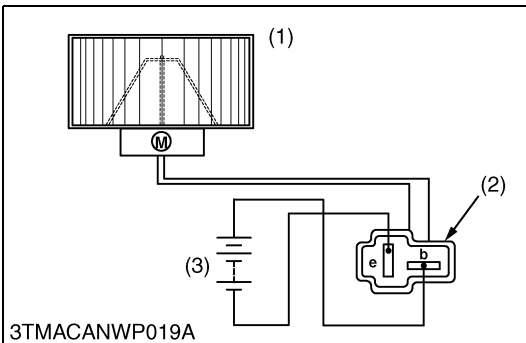
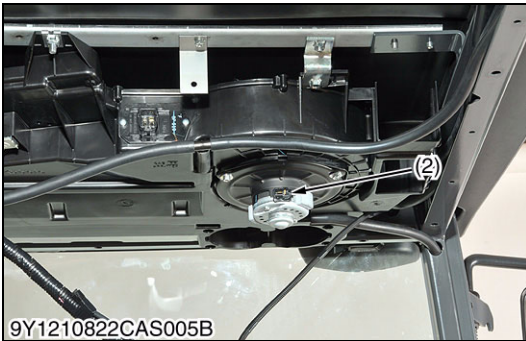

Blower Motor Test

1. Remove the outer roof.
2. Turn the blower motor (1) by hand and check whether it turns smoothly.
3. Disconnect the **2P** connector (2) of blower motor (1).
4. Connect a jumper lead from battery (3) positive terminal to connector terminal **b**.
5. Connect a jumper lead from battery negative terminal to connector terminal **e** momentarily.
6. If the blower motor does not run, check the motor.

- | | |
|---|----------------------|
| (1) Blower Motor | b: Terminal b |
| (2) 2P Connector (Blower Motor Side) | e: Terminal e |
| (3) Battery (12 V) | |

9Y1211109CAS0043US0

(5) Temperature Motor

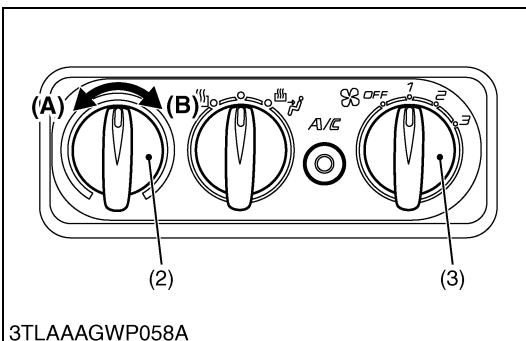
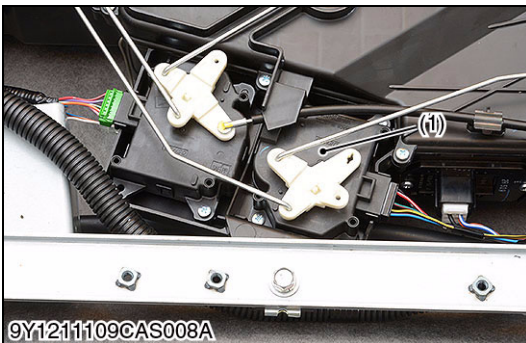

Temperature Motor Checking

1. Make sure whether the temperature control dial (2) is damaged. (See page 10-S26.)
2. Turn the main switch to **"ON"** position.
3. Turn the blower switch (3) at **1** position.
4. Turn the temperature control dial from **"COOL"** position (A) to **"WARM"** position (B). At the time, make sure the motor is operating.
5. If the motor does not operate, replace it.

- | | |
|------------------------------|-----------------|
| (1) Temperature Motor | (A) COOL |
| (2) Temperature Control Dial | (B) WARM |
| (3) Blower Switch | |

9Y1211109CAS0044US0

(6) Mode Motor

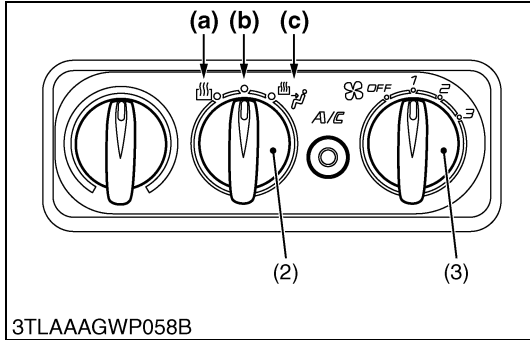
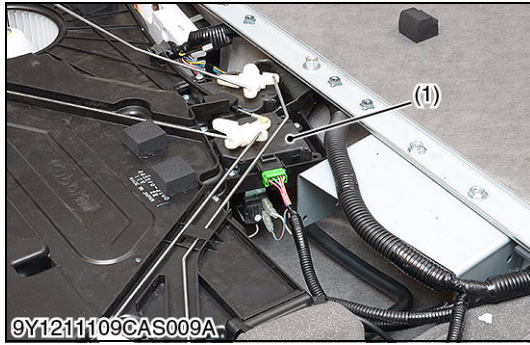

Mode Motor Checking

1. Make sure whether the mode switch (2) is damaged. (See page 10-S25.)
2. Turn the main switch to "ON" position.
3. Turn the blower switch at 1 position.
4. Turn the mode switch each (a), (b) and (c).
5. Make sure whether the position where the mode motor (1) is stopped synchronize with mode switch (2).
6. If the motor does not move, replace it.

- (1) Mode Motor
- (2) Mode Switch
- (3) Blower Switch

- (a) Air is blown from only the defroster air outlet
- (b) Air is blown weaker from the side air outlets (head) and stronger from the front air outlets
- (c) Air is blown from the front and side air outlets

9Y1211109CAS0045US0

(7) Relay

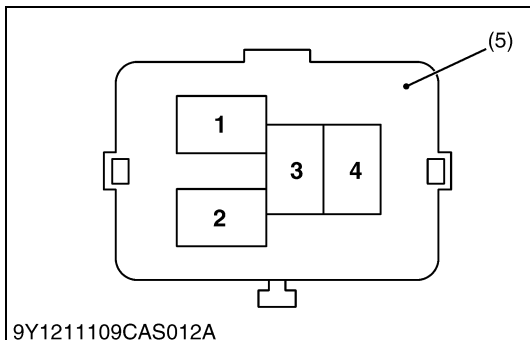
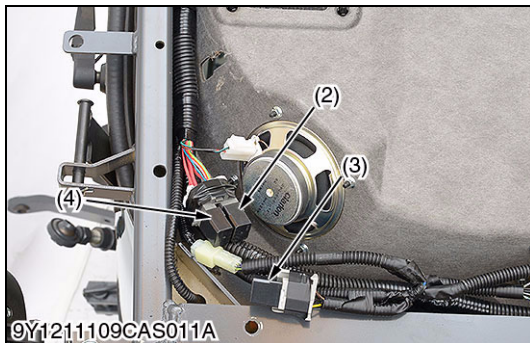
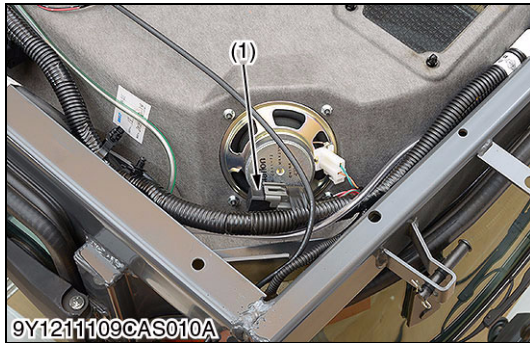

Checking Connector Voltage

1. Measure the voltage with a voltmeter across the battery terminal and chassis as table below.
2. If the voltage differs from the battery, the wiring harness or fuse is faulty.

■ Color of wiring

Item	Terminal No.	Color of Wiring
Blower Relay	1	1.25 R/W
	2	0.5 GY
	3	2.0 R/B
	4	2.0 R
Compressor Relay	1	1.25 R/W
	2	0.5 L/B
	3	1.25 Y/G
	4	1.25 R/W
Front Wiper Relay	1	0.5 B
	2	0.5 Y
	3	0.5 B
	4	0.5 Y/R
Defogger Relay	1	0.5 R/W
	2	0.5 G/Or
	3	2.0 R/L
	4	2.0 R/G

- (1) Blower Relay
- (2) Compressor Relay
- (3) Rear Wiper Switch

- (4) Front Wiper Switch
- (5) Connector (Wire Harness Side)

9Y1211109CAS0046US0

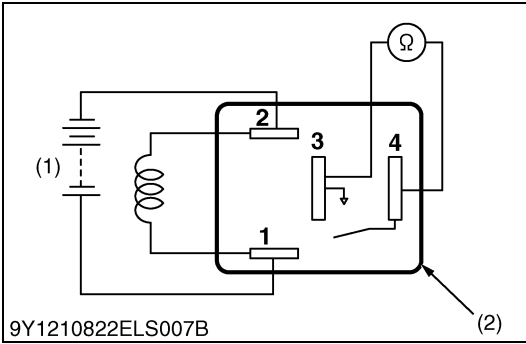

Functional Check

■ **NOTE**

• The relays described here are used same ones so that these are interchangeable.

1. Apply the battery voltage across the terminal 1 and 2, and check for continuity across the terminal 3 and 4.
2. If continuity is not established across the terminal 3 and 4, replace it.

- (1) Battery (2) Connector (Relay)

9Y1211109CAS0051US0

(8) Pressure Switch

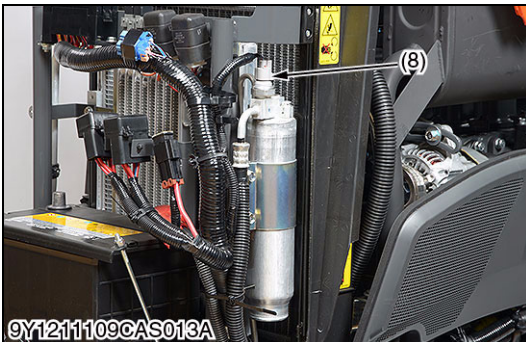
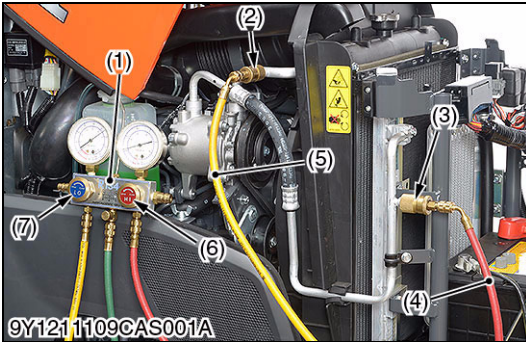

Pressure Switch

1) HI Pressure Side

1. Connect the manifold gauge (1) to compressor as following procedure.
Close the **HI** and **LO** pressure valves (6), (7) of manifold gauge tightly, and connect the charging hoses (4), (5) (red and yellow) to the respective compressor service valves.

■ **NOTE**

• Be sure to drive out the air in the charging hoses at the manifold gauge connection end by utilizing the refrigerant pressure in the refrigerant cycle.

2. Start the engine and set at approx. 1500 min⁻¹ (rpm). Turn on the A/C switch, then set the blower switch to **HI** position.
3. Raise pressure on the **HI** pressure side of the refrigerant cycle by covering the condenser front with a corrugated carboard, and the pressure switch is activated and the compressor magnetic clutch is turned off. At this time, read the **HI** pressure gauge of the manifold gauge. If this pressure reading differs largely with the setting pressure, replace the pressure switch with a new one.

Setting pressure	Factory specification	Pressure switch OFF	More than approx. 3.14 MPa (32 kgf/cm ² , 455 psi)
------------------	-----------------------	----------------------------	---

2) LO Pressure Side

1. Disconnect **2P** connector of pressure switch (8).
2. Measure the resistance with an ohmmeter across the connector terminals.
3. If 0 ohm is not indicated at normal condition, there is no refrigerant in the refrigerating cycle because gas leaks or pressure switch is damaged.

(Reference)

Setting pressure	Factory specification	Pressure switch OFF	Less than approx. 0.196 MPa (2.0 kgf/cm ² , 28.4 psi)
------------------	-----------------------	----------------------------	--

• The resistance of pressure switch is 0 ohm in normal condition, but it becomes infinity if the pressure is out of factory specification. Because the pressure switch starts to work.

- (1) Manifold Gauge (5) Charging Hose (Yellow)
 (2) **LO** Pressure Side Charging Valve (6) **HI** Pressure Side Valve
 (3) **HI** Pressure Side Charging Valve (7) **LO** Pressure Side Valve
 (4) Charging Hose (Red) (8) Pressure Switch

9Y1211109CAS0047US0

(9) Wiper Switch

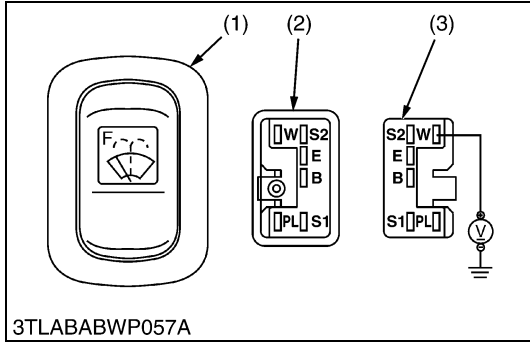
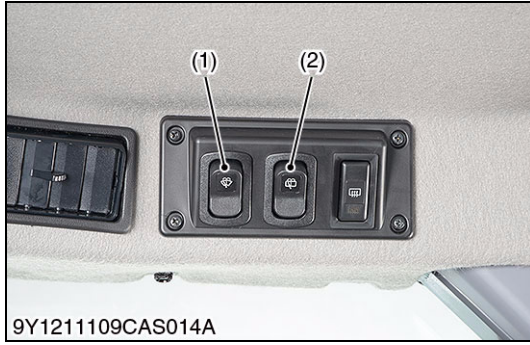

Front and Rear Wiper Switch

1. Remove the switch cover.
2. Disconnect the wiper switch connector.
3. Perform the following checkings **1)** and **2)**.

(1) Front Wiper Switch

(2) Rear Wiper Switch

9Y1211109CAS0048US0

1) Connector Voltage

1. Turn the main switch "ON".
2. Measure the voltage with a voltmeter across the connector **W** terminal and chassis.
3. If the voltage differs from the battery voltage, the wiring harness, fuse or main switch is faulty.

Voltage	W terminal – Chassis	Approx. battery voltage
---------	----------------------	-------------------------

2) Front and Rear Wiper Switch

1. Check the continuity through the switch with an ohmmeter.
2. If continuity specified below is not indicated, the switch is faulty.

Position	Terminal					
	S1	S2	B	W	E	PL
WASH I				●	●	
OFF	●	●				
ON		●	●			
WASH II		●	●	●	●	



9Y1210822CAS020US

(Reference)

- **WASH I:** "OFF" side of the wiper switch remains pushed in.
- **WASH II:** "ON" side remains pushed in after the wiper switch is switched "ON" and remains switched "ON".
- **B:** Earth terminal
- **PL:** To combination switch

(1) Wiper Switch

(3) Wiper Switch Connector

(2) Wiper Switch Connector
(Switch Side)

(Wiring Harness Side)

9Y1211109CAS0049US0

(10) Wiper Motor

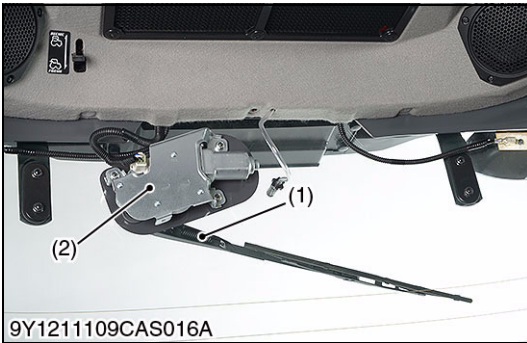
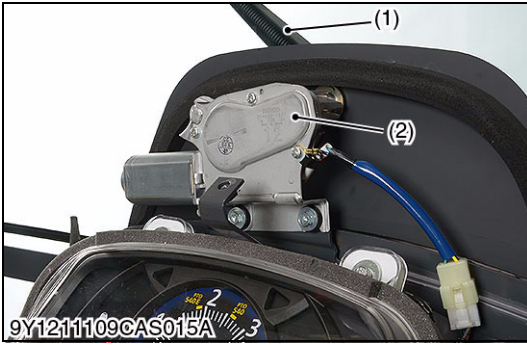

Front and Rear Wiper Motor

1. Raise up the wiper arm (2).
2. Turn the main switch to "ON" position.
3. Push the front wiper switch to "ON" position.
4. Count the number of wiper arm rocking per minutes.
5. If the number differs from the factory specifications, replace the wiper motor assembly.

Number of wiper arm swing frequency at no load	Factory specification	33 to 43 times/min.
--	-----------------------	---------------------

(1) Wiper Arm

(2) Wiper Motor

9Y1211109CAS0050US0

(11) Defogger

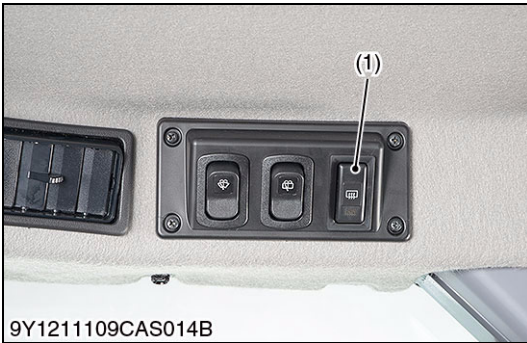

Defogger Switch

1. Remove the switch cover.
2. Disconnect the defogger switch (1).
3. Perform the following checking.

(1) Defogger Switch

9Y1211109CAS0052US0

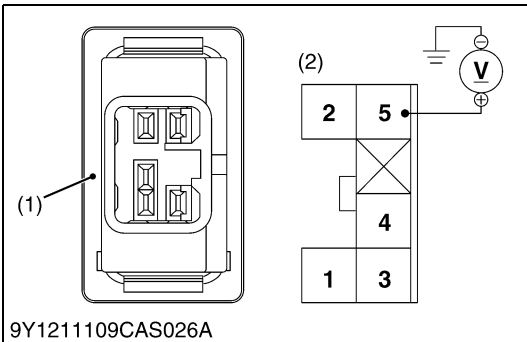

1) Connector Voltage

1. Turn the main switch "ON" position.
2. Measure the voltage with a voltmeter across the terminals shown in the table below.
3. If the reference value as shown in the table below is not indicated, check the relating electric circuit.

Voltage	Main switch at "ON"	Terminal 5 – Chassis	Approx. battery voltage
---------	---------------------	----------------------	-------------------------

(1) Defogger Switch

(2) Connector (Harness Side)

9Y1211109CAS0053US0

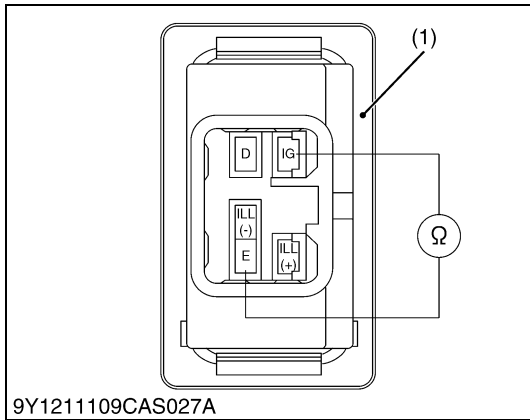

2) Switch Continuity

1. Check the continuity across the terminals shown in the table below.
2. If the continuity specified below is not indicated, the switch is faulty.

Position		Terminal	
		IG	E
Defogger switch	OFF		
	ON	●—●	●—●

9Y1211109CAS028US

(1) Connector (Switch Side)

9Y1211109CAS0054US0

[2] DISASSEMBLING AND ASSEMBLING

(1) Separating Cabin from Tractor Body

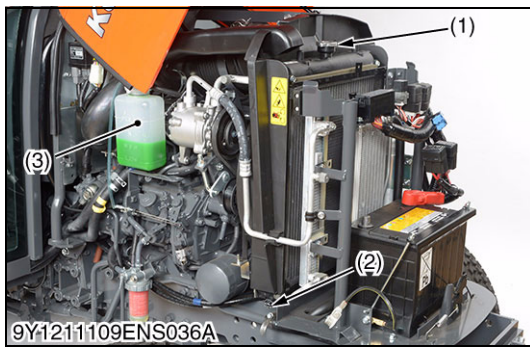

Draining Coolant



WARNING

To avoid personal injury or death:

- Do not remove the radiator cap while coolant is hot. When cool, slowly rotate cap to the first stop and allow sufficient time for excess pressure to escape before removing the cap completely.

1. Stop the engine and let it cool down.
2. To drain the coolant, open the radiator drain plug (2) and remove radiator cap (1). The radiator cap (1) must be removed to completely drain the coolant.
3. After all coolant is drained, reinstall the drain plug (2).

Coolant (with recovery tank)	Capacity	7.1 L 7.5 U.S.qts 6.2 Imp.qts
------------------------------	----------	-------------------------------------

(1) Radiator Cap
(2) Drain Plug

(3) Recovery Tank

9Y1211109ENS0036US0



Rear Wheel and 3-Point Linkage

1. Place the disassembling stand under the transmission case.
2. Remove the rear wheels (1).
3. Remove the top link (2), lift rods (3) and lower links (4).
4. Remove the drawbar (5).

Tightening torque	Rear wheel mounting screw and nut	196.1 to 225.6 N·m 20.0 to 23.0 kgf·m 145 to 166 lbf·ft
-------------------	-----------------------------------	---

(1) Rear Wheel
(2) Top Link
(3) Lift Rod

(4) Lower Link
(5) Drawbar

9Y1211109ENS0037US0

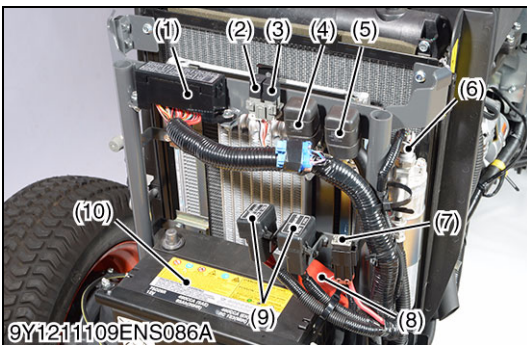
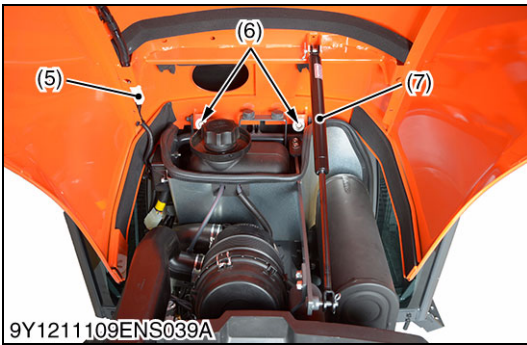
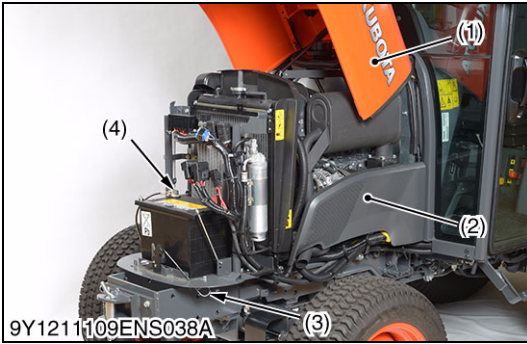

Hood, Side Cover and Battery Cord

1. To open the hood (1), hold the hood (1) and pull the release lever (3) and open the hood (1).
2. Remove the bolt from each of the side covers (2) and remove the side covers (2).
3. Disconnect the battery negative cable (4).
4. Disconnect the head light connector (5) and damper (7).
5. Remove the two screws (6) and then remove the hood (1).

(When reassembling)

NOTE

- When disconnecting the battery cords, disconnect the grounding cord first. When connecting, positive cord first.

- | | |
|----------------------------|--------------------------|
| (1) Hood | (5) Head Light Connector |
| (2) Side Cover | (6) Screw |
| (3) Release Lever | (7) Damper |
| (4) Battery Negative Cable | |

9Y1211109ENS0038US0

Wiring Harness

1. Remove the slow blow fuses (7), (9).
2. Disconnect the battery positive cable (8) from the battery (10).
3. Remove the fuse box (1).
4. Disconnect the relays (2), (3).
5. Remove the electrical outlet relay (4).
6. Remove the key stop relay (5).
7. Disconnect the pressure switch (6).
8. Remove the battery (10).

- | | |
|-----------------------------|---------------------------------|
| (1) Fuse Box | (6) Pressure Switch |
| (2) Head Light Relay | (7) Slow Blow Fuse For Defogger |
| (3) Flasher Relay | (8) Battery Positive Cable |
| (4) Electrical Outlet Relay | (9) Slow Blow Fuse |
| (5) Key Stop Relay | (10) Battery |

9Y1211109ENS0132US0

Steering Wheel

1. Remove the covers (3).
2. Remove the steering wheel cap.
3. Remove the steering wheel mounting nut (1) and remove the steering wheel (2) with a steering wheel puller (Code No. 07916-51090).

(When reassembling)

Tightening torque	Steering wheel mounting nut	48.1 to 55.9 N·m 4.9 to 5.7 kgf·m 35.4 to 41.2 lbf·ft
-------------------	-----------------------------	---

- | | |
|---------------------------------|-----------|
| (1) Steering Wheel Mounting Nut | (3) Cover |
| (2) Steering Wheel | |

9Y1211109ENS0039US0

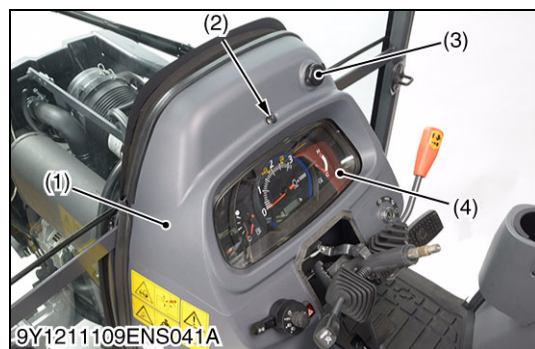

Instrument Panel and Panel Under Cover

1. Remove the screw (2).
2. Open the panel cover (1) and disconnect the electrical outlet connector (5).
3. Open the instrument panel (4) and disconnect the instrument panel connector (6). Then remove the instrument panel (4).

(1) Panel Cover
 (2) Screw
 (3) Electrical Outlet

(4) Instrument Panel
 (5) Electrical Outlet Connector
 (6) Instrument Panel Connector

9Y1211109ENS0040US0

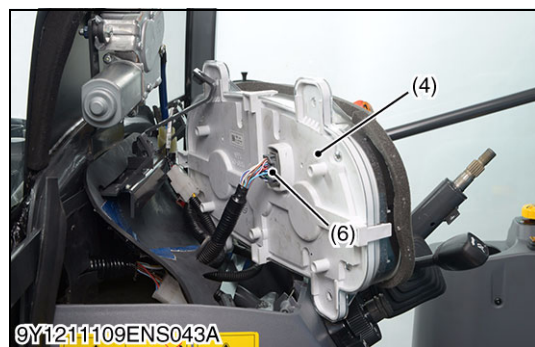
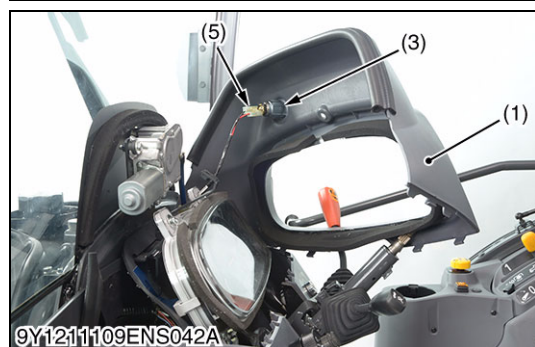

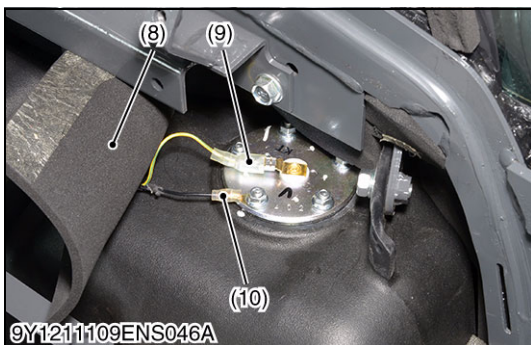
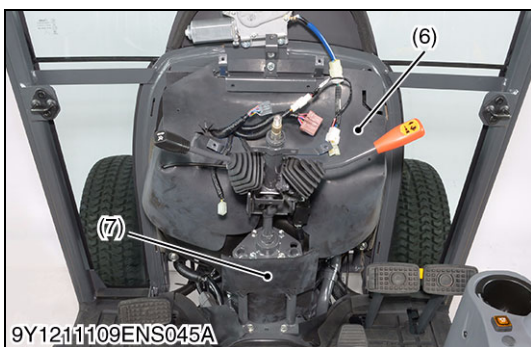

Wiring Harness

1. Disconnect the combination switch connector (5), main switch connector (1), hazard switch connector (4) and wiper motor connector (2).
2. Remove the panel under cover (3).
3. Remove the rubbers (6), (7).
4. Turn over the fuel level sensor cover (8).
5. Disconnect the grounding wire (10) and **1P** connector (9) from the fuel level sensor.

- | | |
|----------------------------------|-----------------------------|
| (1) Main Switch Connector | (6) Rubber |
| (2) Wiper Motor Connector | (7) Rubber |
| (3) Panel Under Cover | (8) Fuel Level Sensor Cover |
| (4) Hazard Switch Connector | (9) 1P Connector |
| (5) Combination Switch Connector | (10) Grounding Wire |

9Y1211109ENS0041US0

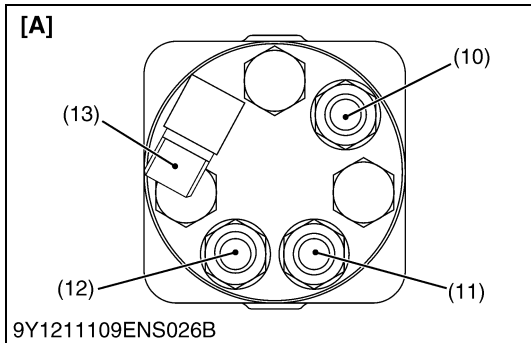
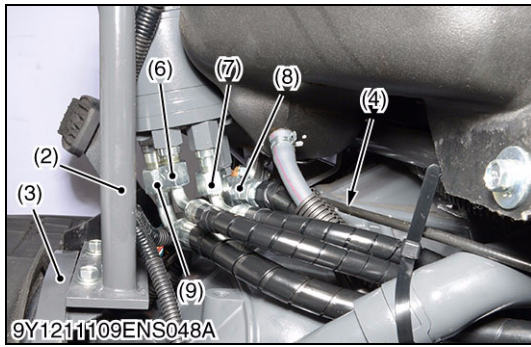
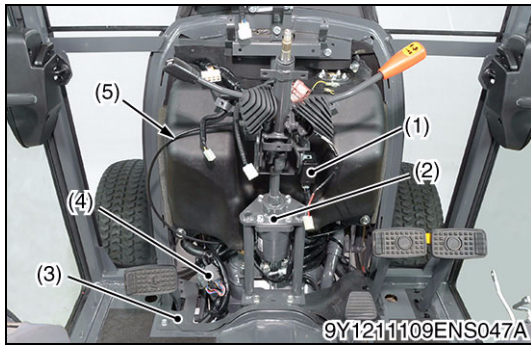

Power Steering Hoses and Steering Support

1. Disconnect the accelerator wire (5) from the engine.
2. Disconnect the OPC controller connector (1) and CABIN joint connectors (4).
3. Remove the step cover (3).
4. Disconnect the delivery hose L.H. (6) and delivery hose R.H. (7) from the steering controller.
5. Disconnect the power steering delivery hose (9) from the steering controller.
6. Disconnect the power steering return hose (8) from the steering controller.
7. Remove the steering support (2) with the steering controller.

(When reassembling)

- Be sure to connect the each hose to original position.
- Be sure to check the hose joints do not interfere in other joints.

Tightening torque	Delivery hose R.H. (4) retaining nut	24.5 to 29.4 N·m 2.5 to 3.0 kgf·m 18.1 to 21.7 lbf·ft
	Delivery hose L.H. (3) retaining nut	24.5 to 29.4 N·m 2.5 to 3.0 kgf·m 18.1 to 21.7 lbf·ft
	Return hose retaining nut	34.3 to 44.1 N·m 3.5 to 4.5 kgf·m 25.3 to 32.5 lbf·ft
	Delivery hose joint screw	45.1 to 53.0 N·m 4.60 to 5.40 kgf·m 33.3 to 39.0 lbf·ft

- | | |
|------------------------------|----------------------------------|
| (1) OPC Controller Connector | (8) Power Steering Return Hose |
| (2) Steering Support | (9) Power Steering Delivery Hose |
| (3) Step Cover | (10) P Port |
| (4) CABIN Joint Connector | (11) LT Port |
| (5) Accelerator Wire | (12) RT Port |
| (6) Delivery Hose L.H. | (13) T Port |
| (7) Delivery Hose R.H. | |
- [A] Viewed from Bottom Side**

9Y1211109ENS0042US0

Step Mat and Seat Under Cover

1. Remove the step mat (3), sound absorber (2) and rubber (1).
2. Remove the grips of the mid PTO lever (7) and front wheel drive lever (8).
3. Remove the dipstick (6).
4. Remove the lowering speed adjusting knob (5).
5. Remove the seat under cover (4).

(When reassembling)

- Do not confuse the grips.
 - Grip (yellow) for the mid PTO lever (7).
 - Grip (red) for the front wheel drive lever (8).

- | | |
|----------------------|-----------------------------------|
| (1) Rubber | (5) Lowering Speed Adjusting Knob |
| (2) Sound Absorber | (6) Dipstick |
| (3) Step Mat | (7) Mid PTO Lever |
| (4) Seat Under Cover | (8) Front Wheel Drive Lever |

9Y1211109ENS0043US0

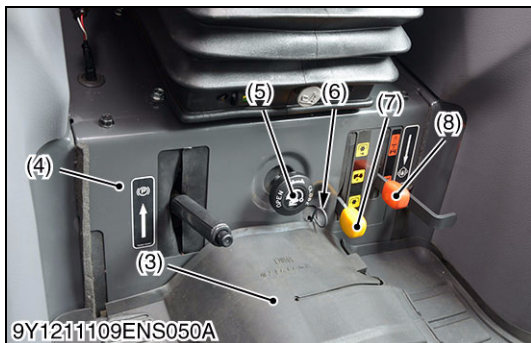
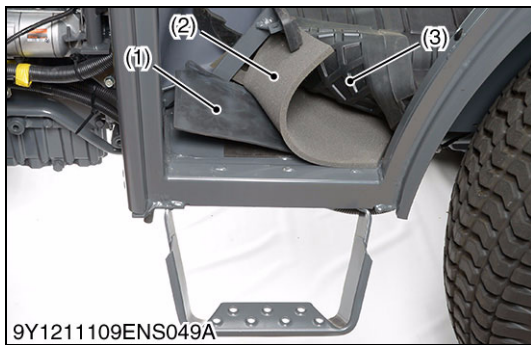

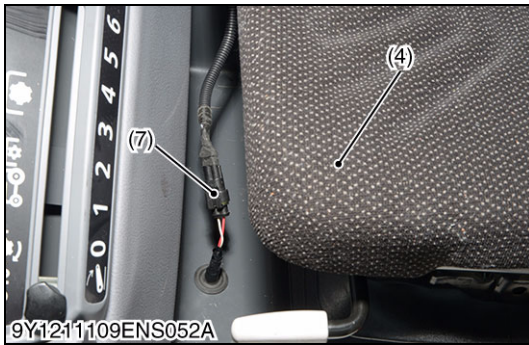
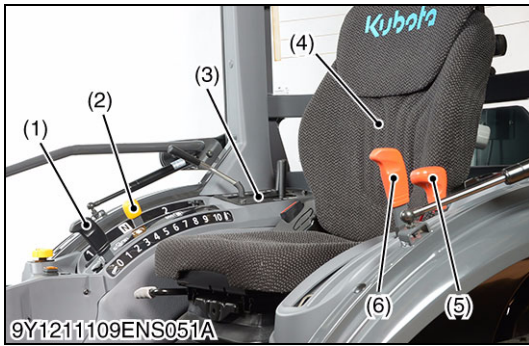

Seat and Lever Grip

1. Disconnect the seat switch connector (7) and remove the seat (4).
2. Remove the grips of the rear PTO shift lever (2), position control lever (1), cruise control lever (5) and range gear shift lever (6).
3. Remove the remote control lever guide (3).

(When reassembling)

- Do not confuse the grips.
 - Grip (yellow) for the rear PTO shift lever (2).
 - Grip (red) for the range gear shift lever (6).

- | | |
|---------------------------------|---------------------------------|
| (1) Position Control Lever Grip | (5) Cruise Control Lever Grip |
| (2) Rear PTO Shift Lever Grip | (6) Range Gear Shift Lever Grip |
| (3) Remote Control Lever Guide | (7) Seat Switch Connector |
| (4) Seat | |

9Y1211109ENS0044US0

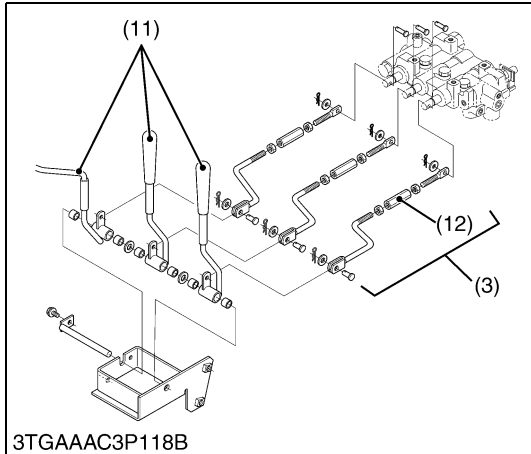
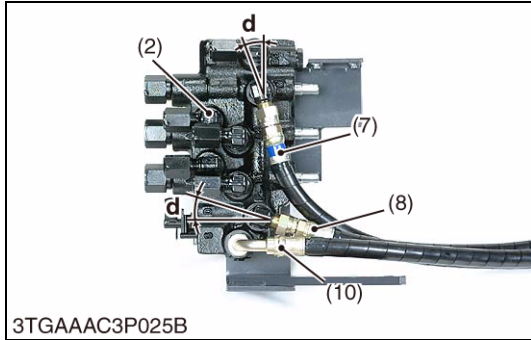
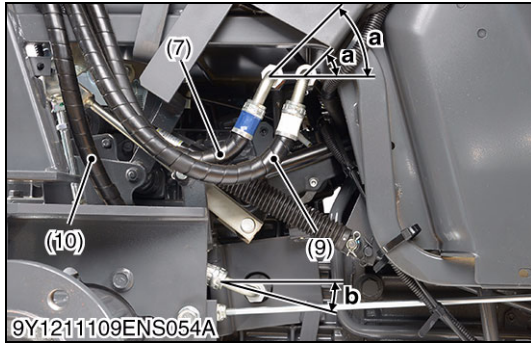
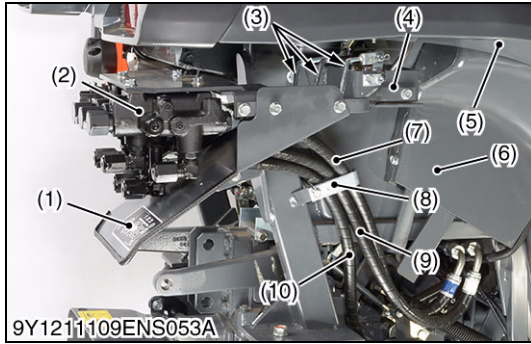

Auxiliary Control Valve and Covers

1. Remove the valve cover (1).
2. Remove the valve stay (4).
3. Remove the connecting rods (3).

(When reassembling)

- Reassemble the connecting rods (3) as shown in the figure.
- After reassembling the valve stay (4), adjust to locate the control lever (11) at a central position of the guide slot with the turnbuckle (12).

4. Remove the hose clamp (8).

(When reassembling)

- Clamp the hydraulic hoses in order of hydraulic hose **PB** (7), hydraulic hose **P** (9) and hydraulic hose **T** (10) from the front side.

5. Disconnect the hydraulic hoses (7), (9), (10) from the tractor body.

6. Remove the auxiliary control valve (2) with the hydraulic hoses (7), (9), (10).

7. Remove the remote control lever bracket with the remote control lever (11).

(When reassembling)

- Assemble the hose joints to appropriate positions referring to the table below.

8. Remove the fender under cover (5) and fender cover (6).

(Distinction and installation angle of the hose joints)

Hydraulic Hose	Hose Joint (Valve side)	Hose Joint (Tractor body side)
P (9)	Straight joint 0.26 rad (15 °)	Bent joint with white tape 0.785 rad (45 °)
PB (7)	Straight joint with blue tape 0.26 rad (15 °)	Bent joint with blue tape 0.785 rad (45 °)
T (10)	Bent joint 1.57 rad (90 °)	Bent joint 0.349 to 0.523 rad (20 to 30 °)
Tightening torque	Hydraulic hose PB , P and T retaining nuts	30 to 40 N·m 3.1 to 4.0 kgf·m 23 to 29 lbf·ft

- | | |
|---|---|
| <ul style="list-style-type: none"> (1) Valve Cover (2) Auxiliary Control Valve (3) Connecting Rod (4) Valve Stay (5) Fender Under Cover (6) Fender Cover (7) Hydraulic Hose PB (8) Hose Clamp (9) Hydraulic Hose P | <ul style="list-style-type: none"> (10) Hydraulic Hose T (11) Remote Control Lever (12) Turnbuckle <p>a: 0.785 rad (45 °)
 b: 0.349 to 0.523 rad (20 to 30 °)
 c: 0.26 rad (15 °)
 d: 0.26 rad (15 °)</p> |
|---|---|

9Y1211109ENS0045US0



Fender Assembly

1. Remove the fender cover (1).
2. Remove the sponges (4), (5).

(When reassembling)

- Assemble the sponge (center) (4) between the cruise control lever (2) and range gear shift lever (6).

- | | |
|--------------------------|----------------------------|
| (1) Fender Cover | (4) Sponge (Center) |
| (2) Cruise Control Lever | (5) Sponge (Outer) |
| (3) Sponge (Inner) | (6) Range Gear Shift Lever |

9Y1211109ENS0046US0

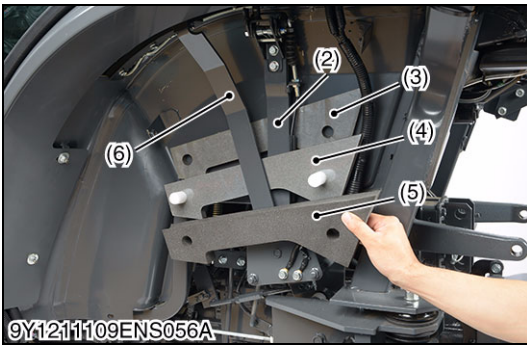

Release Wire and Wiring Harness (Left Side)

1. Remove the fender under cover (1).
2. Remove the release wire (3).
3. Remove the lever guide mounting screws (2), and then open the lever guide (4).
4. Disconnect the wiring connectors for the bi-speed controller connectors (5) and electrical outlet connector (6).
5. Remove the lever guide (4) with bi-speed controller.

- | | |
|-----------------------------------|-----------------------------------|
| (1) Fender Under Cover | (4) Lever Guide |
| (2) Lever Guide Mounting Screw | (5) Bi-speed Controller Connector |
| (3) Release Wire (Cruise Control) | (6) Electrical Outlet Connector |

9Y1211109ENS0047US0

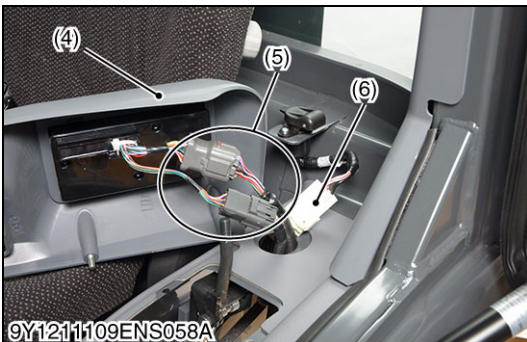
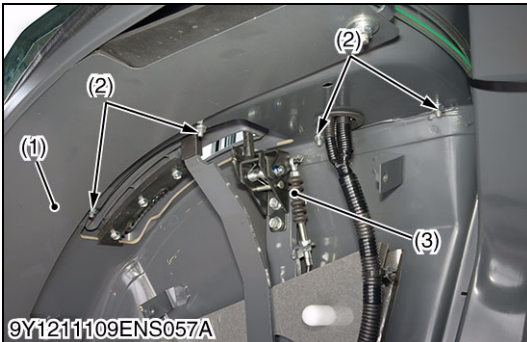



Wiring Harness (Right Side)

1. Remove the loader lever guide mounting screws (1).
2. Open the loader lever guide (2) and then disconnect the connectors for PTO switch (4) and beacon switch (3).

- | | |
|---------------------------------------|-------------------|
| (1) Loader Lever Guide Mounting Screw | (3) Beacon Switch |
| (2) Loader Lever Guide | (4) PTO Switch |

9Y1211109ENS0049US0



Wiring Harness

1. Pull down the grommet (1) for seat switch connector.
2. Remove the clamp (2).

- | | |
|-------------|-----------|
| (1) Grommet | (2) Clamp |
|-------------|-----------|

9Y1211109ENS0050US0

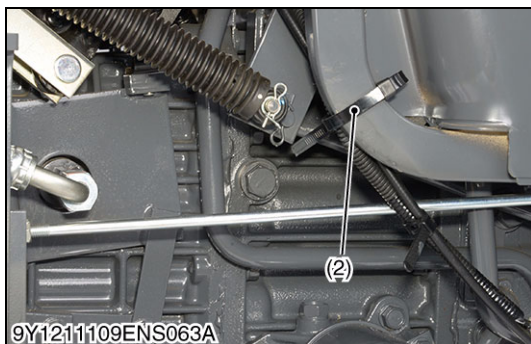
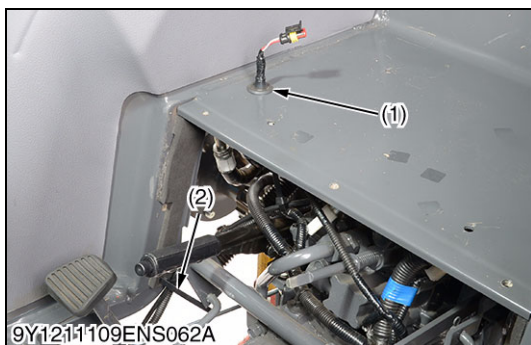

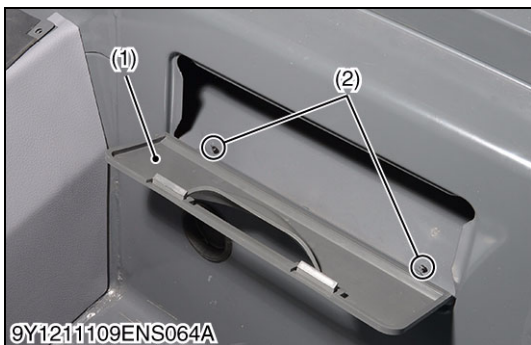

Wiring Harness (Rear Side)

1. Open the tool box (1).
2. Remove the clamps (2), (3) from the Cabin.
3. Disconnect the registration lamp connectors (4).
4. Disconnect the washer motor connectors (5).
5. Disconnect the PTO switch connector (6).

(When reassembling)

- Do not confuse the connectors.
 - Connector (white) for the front washer motor.
 - Connector (gray) for the rear washer motor.

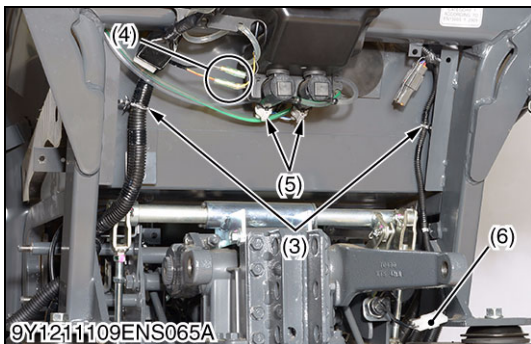

- | | |
|--------------|---------------------------------|
| (1) Tool Box | (4) Registration Lamp Connector |
| (2) Clamp | (5) Washer Motor Connector |
| (3) Clamp | (6) PTO Switch Connector |

9Y1211109ENS0051US0

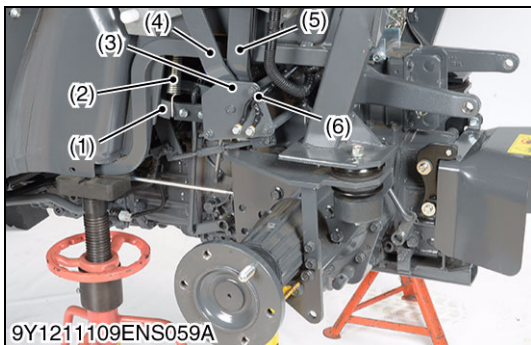

Differential Lock Pedal and Levers

1. Remove the differential lock pedal (1) with the spring (2).
2. Remove the grounding cable (6) mounting screws.
3. Remove the plate (3).
4. Remove the range gear shift lever (4) and cruise control lever (5).

- | | |
|-----------------------------|----------------------------|
| (1) Differential Lock Pedal | (4) Range Gear Shift Lever |
| (2) Spring | (5) Cruise Control Lever |
| (3) Plate | (6) Grounding Cable |

9Y1211109ENS0048US0

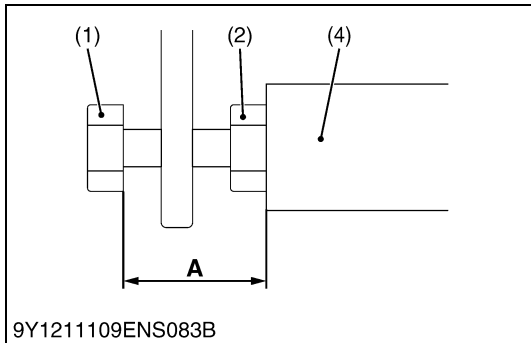
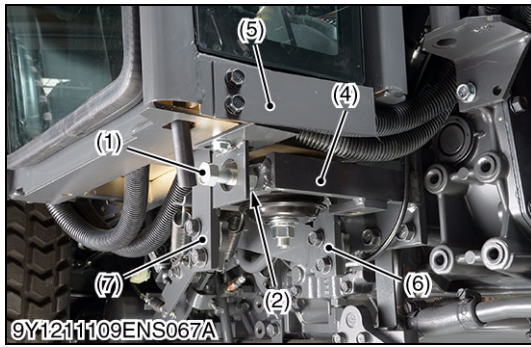
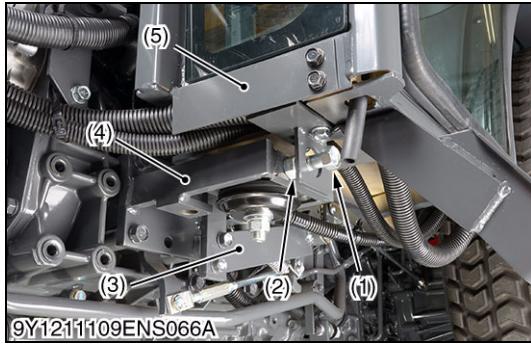

Clutch Pedal, Brake Pedal and Cabin Stopper Bolt

1. Remove the both sides of hose plate (5).
2. Remove the clutch pedal (3).
3. Remove the brake pedal L.H. (6) and R.H. (7)
4. Loosen the both sides of lock nut (2), and then remove the both sides of stopper bolt (1)

(When reassembling)

- Be sure to install the stopper bolt to the original positions.

- | | |
|-------------------|--|
| (1) Stopper Bolt | (5) Hose Plate |
| (2) Lock Nut | (6) Brake Pedal L.H. |
| (3) Clutch Pedal | (7) Brake Pedal R.H. |
| (4) Front Bracket | A: 38 to 42 mm (1.5 to 1.6 in.) |

9Y1211109ENS0052US0

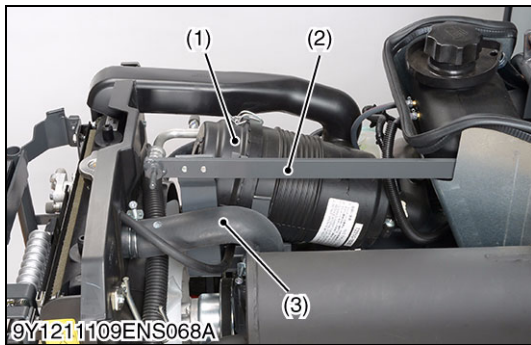

Air Cleaner and Radiator Hoses

1. Remove the air cleaner (1) with air cleaner hose.
2. Remove the damper stay (2)
3. Remove the radiator upper hose (3) and lower hose (4).

- | | |
|-----------------|-------------------------|
| (1) Air Cleaner | (3) Radiator Upper Hose |
| (2) Damper Stay | (4) Radiator Lower Hose |

9Y1211109ENS0053US0

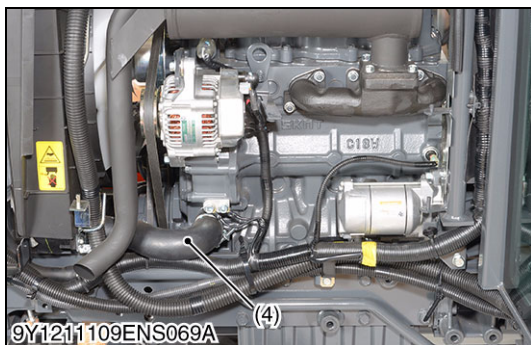

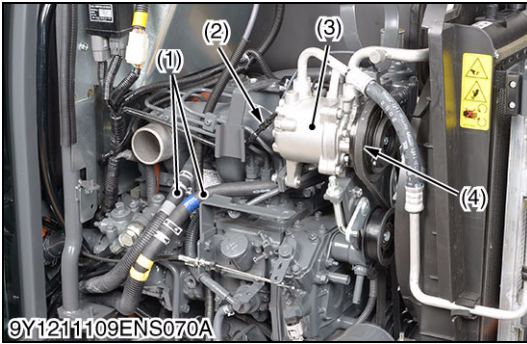

9Y1211109ENS070A

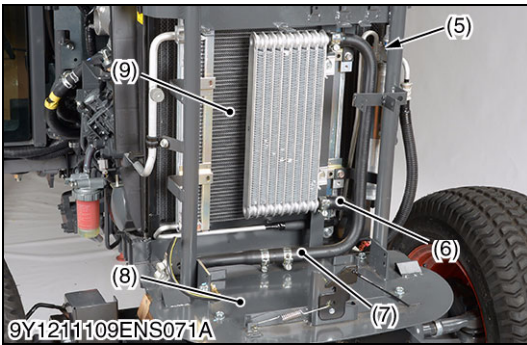

9Y1211109ENS071A

Air Compressor and Oil Hoses

1. Disconnect the heater hoses (1), and then reconnect their hoses to make loop.

■ **NOTE**

- **Put a mark to the each heater hose before disconnecting.**
2. Remove the air conditioner belt (4).
 3. Disconnect the compressor 1P connector (2).
 4. Disconnect the oil cooler inlet hose (6) and outlet hose (7).
 5. Remove the battery stay mounting bolt.
 6. Remove the compressor mounting screws.
 7. Remove the compressor (3), condenser (9), receiver (5), battery stay (8) and etc. as a unit.

(When reassembling)

- After reassembling the compressor, be sure to adjust the air conditioner belt tension. (See page G-31.)

- | | |
|-----------------------------|----------------------------|
| (1) Heater Hose | (6) Oil Cooler Inlet Hose |
| (2) Compressor 1P Connector | (7) Oil Cooler Outlet Hose |
| (3) Compressor | (8) Battery Stay |
| (4) Air Conditioner Belt | (9) Condenser |
| (5) Receiver | |

9Y1211109ENS0054US0

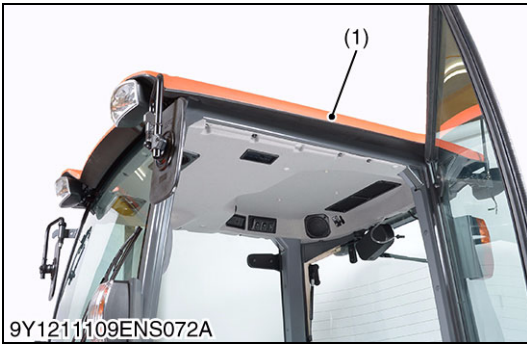

9Y1211109ENS072A

Cabin Assembly

1. Remove the outer roof (1) of cabin.
2. Support the cabin with nylon straps (2), cabin dismantling tool (3) and hoists.
3. Loosen and remove the cabin mounting screw (4) and nuts (10).
4. Dismounting the cabin from tractor body.

■ **NOTE**

- **Lift the cabin while making sure it does not catch on anything.**

(When reassembling)

- Be sure to install the washers and mount rubbers, etc. in their original positions.

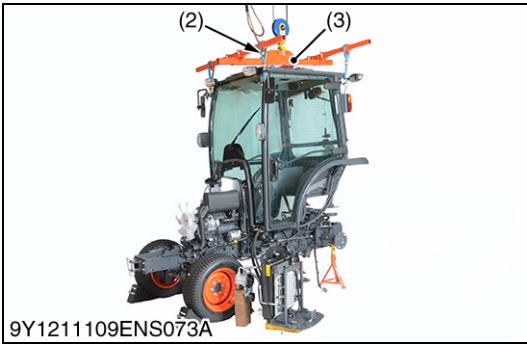

9Y1211109ENS073A

Tightening torque	Outer roof mounting screw	3.5 to 4.0 N·m 0.36 to 0.40 kgf·m 2.6 to 2.9 lbf·ft
	Cabin mounting bolt and nut	124 to 147 N·m 12.6 to 15.0 kgf·m 91.1 to 108 lbf·ft

- | | |
|----------------------------|-------------------|
| (1) Outer Roof | (8) Plane Washer |
| (2) Nylon Strap | (9) Spring Washer |
| (3) Cabin Dismounting Tool | (10) Nut |
| (4) Screw | (11) Collar |
| (5) Plate | |
| (6) Mount Rubber | |
| (7) Collar | |
- F: Front Side**
R: Rear Side

9Y1211109ENS0055US0

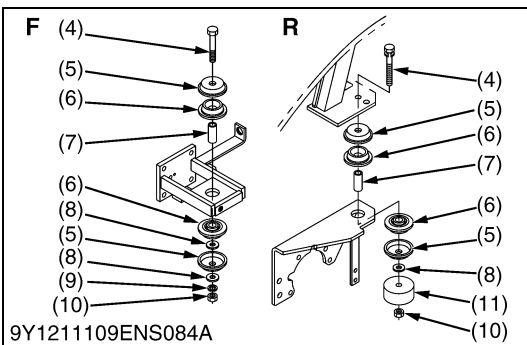

9Y1211109ENS084A

(2) Removing Compressor Assembly

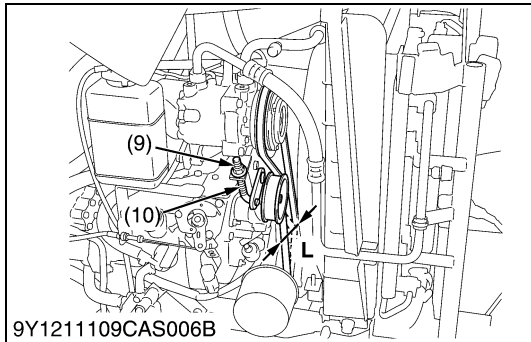
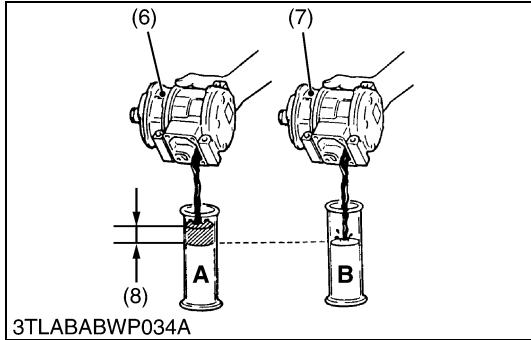
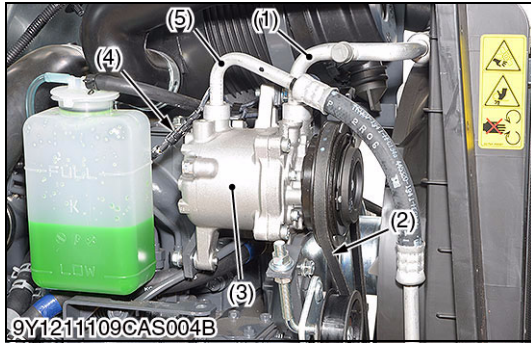

Compressor Assembly

1. Discharge the refrigerant from the system. (See page 10-S18.)
2. Disconnect the low pressure pipe (suction) (1) and high pressure pipe (discharge) (5) from the compressor, then cap the open fitting immediately to keep moisture out of the system.
3. Disconnect the **1P** connector (4) of magnetic clutch.
4. Remove the air conditioner belt (2) and remove the compressor (3) with stay.

(When reassembling)

- After reassembling the compressor, be sure to adjust the air conditioner belt tension and recharge the refrigerant to the system. (See page 10-S20, 10-S23.)
- Apply compressor oil (DENSO CO. ND-OIL8 or equivalent) to the O-rings and be careful not to damage them.
- **"S"** letter is marked on the compressor for connecting the low pressure pipe (suction side).
- **"D"** letter is marked on the compressor for connecting the high pressure pipe (discharge side).
- When replacing the compressor with a new one, meet the oil amount with old one.
- Push on the belt between the pulleys with a finger. Deflection **"L"** of 14 to 16 mm (0.56 to 0.62 in.) under a 98 N (10 kgf, 22 lbf) load is appropriate.

Tightening torque	High pressure pipe and low pressure pipe mounting screw	7.85 to 11.8 N·m 0.801 to 1.20 kgf·m 5.79 to 8.70 lbf·ft
	Compressor mounting screws	24.5 to 29.4 N·m 2.50 to 2.99 kgf·m 18.1 to 21.6 lbf·ft

- (1) Low Pressure Pipe
- (2) Air Conditioner Belt
- (3) Compressor
- (4) **1P** Connector (Magnetic Clutch)
- (5) High Pressure Pipe 1
- (6) New Compressor
- (7) Old Compressor
- (8) Remove the Excess Oil (**A-B**)
- (9) Lock Nut
- (10) Adjusting Bolt

- A:** Oil Flow New Compressor
B: Oil Flow Replace Compressor
L: Deflection
14 to 16 mm (0.56 to 0.62 in.)

9Y1211109CAS005US0

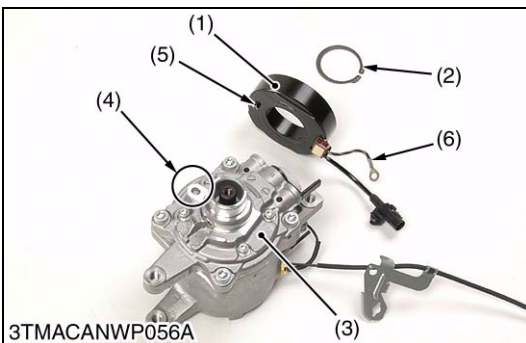
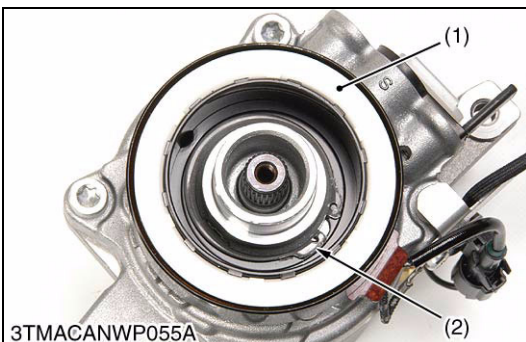
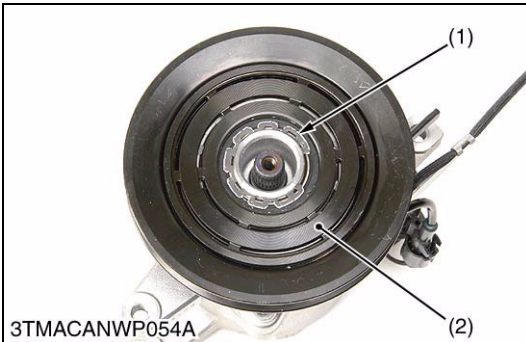
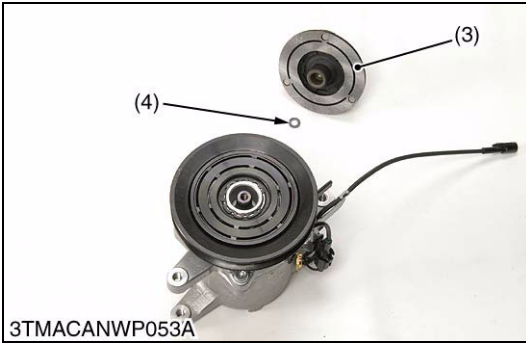
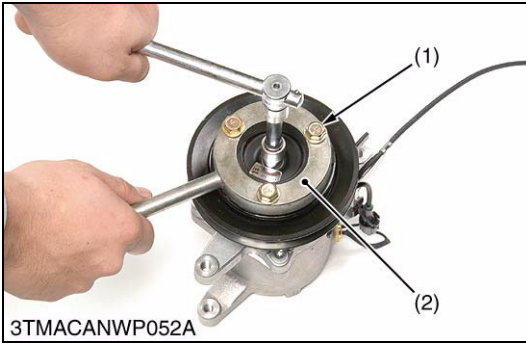

Hub Plate

1. Three stopper bolts (1) are set in stopper magnetic clutch (2) at the position corresponding to the shape of compressor.
2. The stopper magnetic clutch (2) is hung on hub plate (3) and it is fixed that the compressor rotates.
3. Remove the magnetic clutch mounting screw.
4. Remove the hub plate (3) and air gap adjustment shim (4).

(When reassembling)

- Do not apply grease or oil on the hub plate facing.
- Do not use the magnetic clutch mounting screw again.
- Make sure to turn rotor by hand after assembling and not contact with stator and hub plate.
- Check and adjust the air gap before tight the magnet clutch mounting screw to the specified torque.

Tightening torque	Magnetic clutch mounting screw	15 to 21 N·m 1.5 to 2.1 kgf·m 11 to 15 lbf·ft
-------------------	--------------------------------	---

- (1) Stopper Bolt (3) Hub Plate
(2) Stopper Magnetic Clutch (4) Shim

9Y1211109CAS0056US0

Rotor

1. Remove the external circlip (1).
2. Remove the rotor (2).

(When reassembling)

- Do not use the external circlip again.
- Assemble the external circlip for the tapered side to become outside of rotor.
- The width of expanding of external circlip is set in boss of shaft as a minimum.

(Reference)

- Code No. for external circlip: T1065-87450

- (1) External Circlip (2) Rotor

9Y1211109CAS0057US0

Stator

1. Remove the lead wire (6) from compressor body.
2. Remove the external circlip (2).
3. Remove the stator (1).

(When reassembling)

- Do not use the external circlip again.
- Assemble the external circlip for the tapered side to become outside of front housing.
- The width of expanding of external circlip is set is boss of shaft as a minimum.
- Match and assemble the concave part (4) of the front housing (3) and the pin (5) of stator.

(Reference)

- Code No. for external circlip: T1065-87440

- (1) Stator (4) Concave Part
(2) External Circlip (5) Pin
(3) Front Housing (6) Lead Wire

9Y1211109CAS0058US0

(3) Removing Air Conditioner Unit

Draining Coolant

- See page 10-S32.

9Y1211109CAS0059US0

Discharging Refrigerant

- See page 10-S18.

9Y1211109CAS0060US0

Outer Roof and Stay

1. Remove the outer roof (1).
2. Remove the stay (3).

Tightening torque	Outer roof mounting screw	3.5 to 4.0 N·m 0.36 to 0.40 kgf·m 2.6 to 2.9 lbf·ft
-------------------	---------------------------	---

- (1) Outer Roof (3) Stay
(2) Inner Roof

9Y1211109CAS0061US0

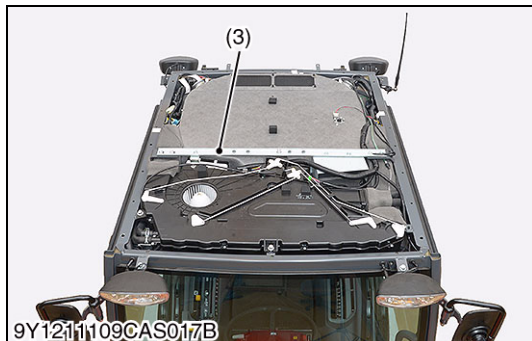
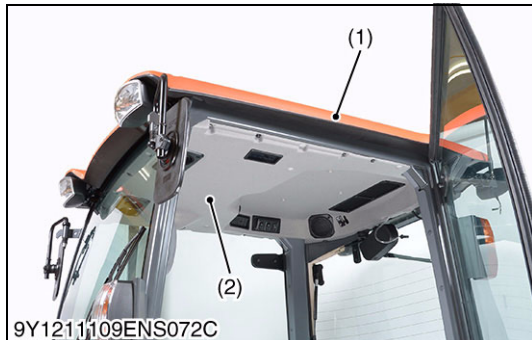

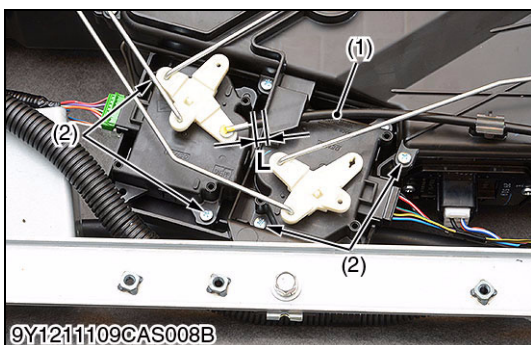
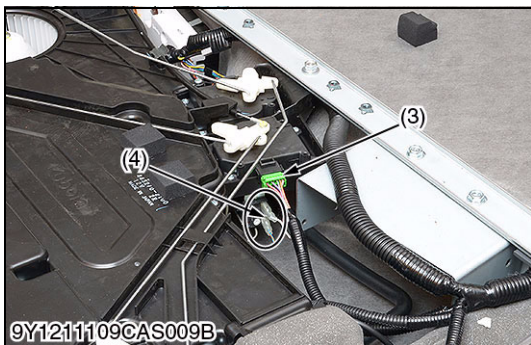
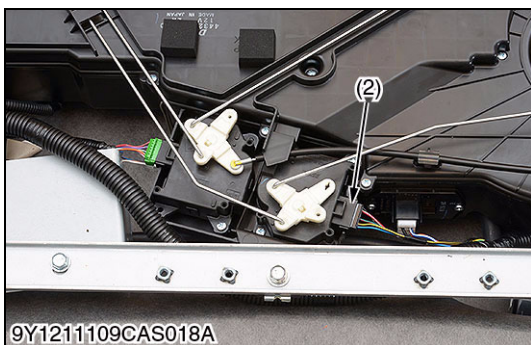

Wiring Harness

1. Disconnect the temperature motor connector (3), and thermostat connectors (4).
2. Disconnect the mode motor connector (2) and blower resistor (1) connector.

- | | |
|--------------------------|---------------------------------|
| (1) Blower Resister | (3) Temperature Motor Connector |
| (2) Mode Motor Connector | (4) Thermostat Connector |

9Y1211109CAS0062US0

Wire Cable, Temperature Motor and Mode Motor

1. Disconnect the wire cable (1).
2. Remove the motor mounting screws (2).

- | | |
|--------------------------|--------------------------|
| (1) Wire Cable | L: 6 mm (0.2 in.) |
| (2) Motor Mounting Screw | |

9Y1211109CAS0063US0

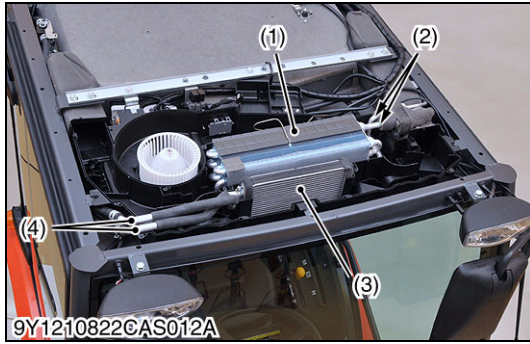

Air Conditioning Unit

1. Remove the unit cover.
2. Disconnect the heater hoses (4).
3. Remove the joint mounting screw and then disconnect the air conditioner pipes (2).
4. Remove the screws and remove the unit.
5. Remove the duct hoses.

(When reassembling)

- When reconnecting the cooler pipes with the unit, apply compressor oil (DENSO CO. ND-OIL8 or equivalent) to O-rings.
- When remounting the unit, tighten five screws by hand and finally retighten them after aligning the inner roof duct with the unit duct.
- When connecting the heater hose with A/C unit, hose should be put into the A/C unit pipe more than 10 mm (0.39 in.)

Tightening torque	A/C unit mounting screw (M6)	3.9 to 6.8 N·m 0.40 to 0.70 kgf·m 2.9 to 5.0 lbf·ft
	A/C unit mounting screw (M8)	9.81 to 11.6 N·m 1.00 to 1.19 kgf·m 7.24 to 8.60 lbf·ft
	Joint mounting screw	7.85 to 11.8 N·m 0.801 to 1.20 kgf·m 5.79 to 8.70 lbf·ft

- (1) Evaporator
- (2) Air Conditioner Pipe
- (3) Heater Core
- (4) Heater Hoses

9Y1211109CAS0064US0

(4) Removing Air Conditioner Pipes

Discharging Refrigerant

- See page 10-S18.

9Y1211109CAS0065US0

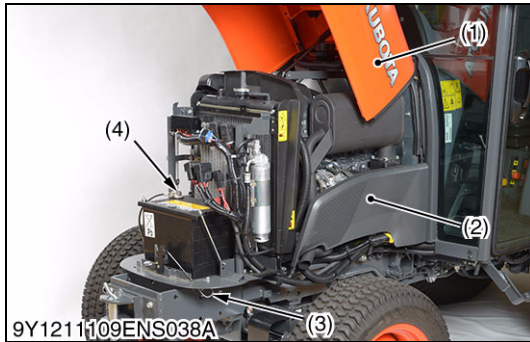

Hood, Side Cover and Battery Cord

1. To open the hood (1), hold the hood (1) and pull the release lever (3) and open the hood (1).
2. Remove the bolt from each of the side covers (2) and detach the side covers (2).
3. Disconnect the battery negative cable (4).
4. Disconnect the head light connector (5) and damper (7).
5. Remove the two screws (6) and then remove the hood (1).
6. Remove the air cleaner (8).

(When reassembling)

NOTE

- **When disconnecting the battery cords, disconnect the grounding cord first. When connecting, positive cord first.**

- (1) Hood
- (2) Side Cover
- (3) Release Lever
- (4) Battery Negative Cable
- (5) Head Light Connector
- (6) Screw
- (7) Damper
- (8) Air Cleaner

9Y1211109CAS0082US0

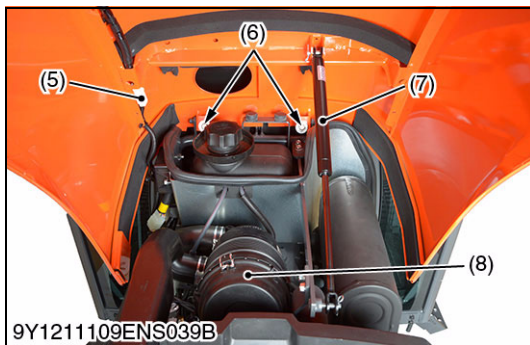

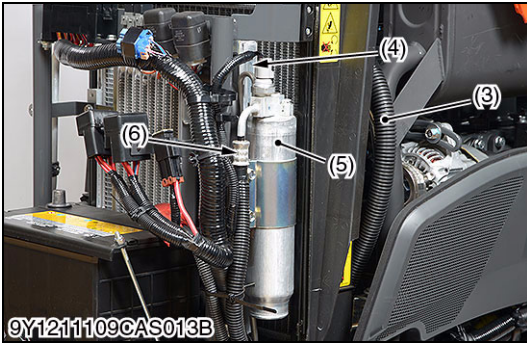
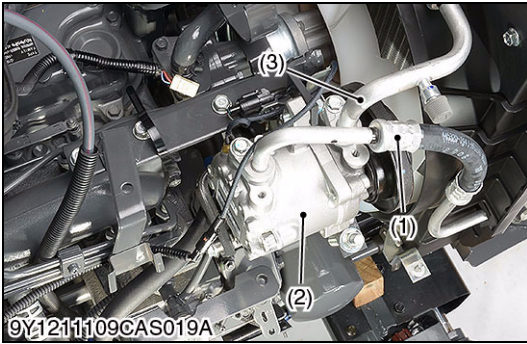

High Pressure Hose 1, 2 and Low Pressure Hose

1. Disconnect the low pressure hose (3) and high pressure hose 1 (1) from the compressor (2), then cap the open fittings immediately to keep moisture out of the system.
2. Slide the condenser (4).
3. Disconnect the high pressure hose 1 (1) from the condenser (4) and cap the place immediately which disconnected pressure hose to keep moisture out of the system.
4. Disconnect the high pressure hose 2 (6) from the receiver (5) and cap the place immediately which disconnected pressure hose to keep moisture out of the system.

(When reassembling)

- Apply compressor oil (DENSO CO. ND-OIL8) to the O-rings and be careful not to damage them.

Tightening torque	Low pressure hose mounting screw (compressor side)	7.85 to 11.8 N·m 0.801 to 1.20 kgf·m 5.79 to 8.70 lbf·ft
	High pressure hose 1 mounting screw (compressor side)	7.85 to 11.8 N·m 0.801 to 1.20 kgf·m 5.79 to 8.70 lbf·ft
	High pressure hose 1 mounting screw (condenser side)	3.9 to 6.8 N·m 0.40 to 0.69 kgf·m 2.9 to 5.0 lbf·ft
	High pressure hose 2 mounting screw (receiver side)	3.9 to 6.8 N·m 0.40 to 0.69 kgf·m 2.9 to 5.0 lbf·ft
	High pressure hose 2 mounting screw (condenser side)	3.9 to 6.8 N·m 0.40 to 0.69 kgf·m 2.9 to 5.0 lbf·ft

- | | |
|--------------------------|--------------------------|
| (1) High Pressure Hose 1 | (4) Condenser |
| (2) Compressor | (5) Receiver |
| (3) Low Pressure Hose | (6) High Pressure Hose 2 |

9Y1211109CAS0067US0

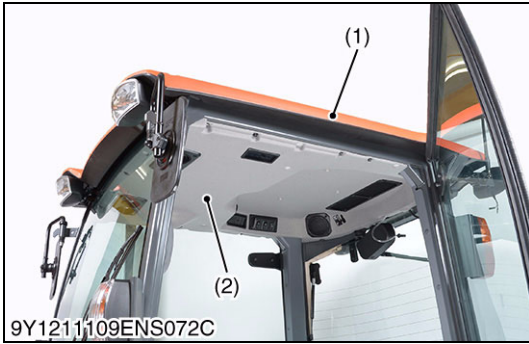

High Pressure and Low Pressure Pipes

1. Remove the outer roof (1) and inner roof (2).
2. Remove the inner cover (3).
3. Remove the joint mounting screw and joint.
4. Disconnect the high pressure pipe 2 (5), then cap the open fitting immediately to keep moisture out of the system.
5. Disconnect the low pressure pipe (4), then cap the open fittings immediately to keep moisture out of the system.

Tightening torque	Joint mounting screw	7.85 to 11.8 N·m 0.801 to 1.20 kgf·m 5.79 to 8.70 lbf·ft
-------------------	----------------------	--

- | | |
|-----------------|--------------------------|
| (1) Outer Roof | (4) Low Pressure Pipe |
| (2) Inner Roof | (5) High Pressure Pipe 2 |
| (3) Inner Cover | |

9Y1211109CAS0068US0

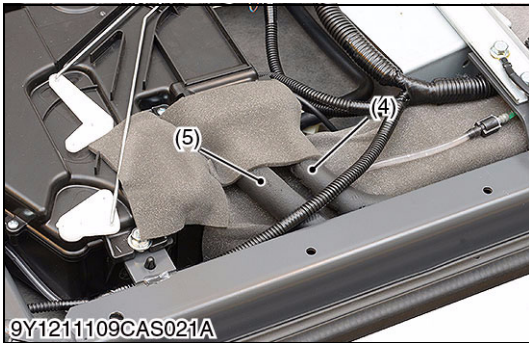

(5) Removing Heater Hoses

Draining Coolant

- See page 10-S32.

9Y1211109CAS0070US0

Hood, Side Cover and Battery Cord

- See page 10-S33.

9Y1211109CAS0066US0

Hose Clamp

1. Remove the hose plate.
2. Disconnect the heater hoses (1), then remove them under the cabin.

NOTE

- Before disconnecting the heater hoses (1), put the parting marks on the hoses for marking proper reconnecting.

(When reassembling)

- Connecting the heater hoses at their original position.

- (1) Heater Hoses

9Y1211109CAS0072US0

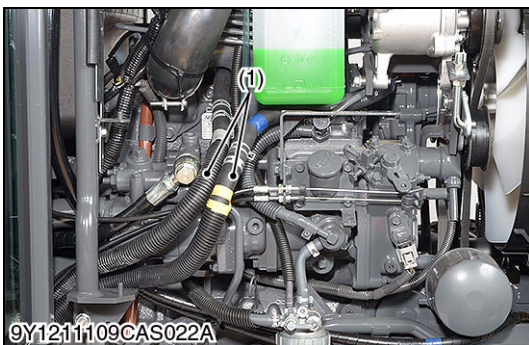

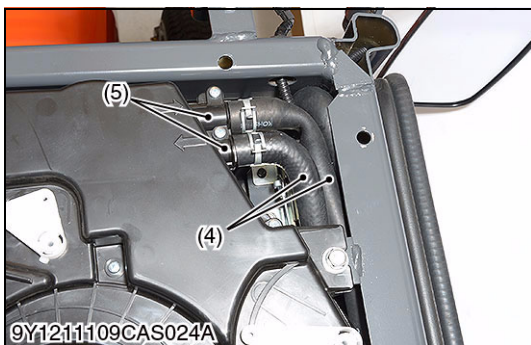
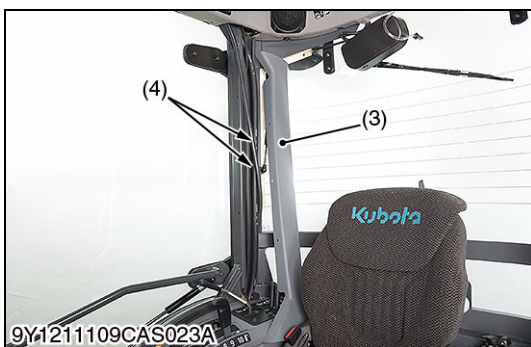
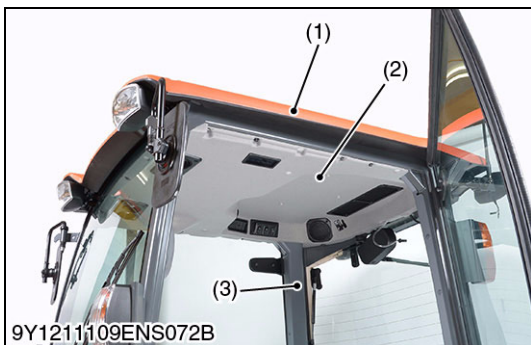

Heater Hoses

1. Remove the outer roof (1), inner roof (2) and inner cover (3).
2. Disconnect the heater hoses (4) from the hose pipes (5).
3. Pull out the heater hoses (4) from the bottom of the cabin.
4. Remove the heater hoses (4).

NOTE

- Before disconnecting the heater hoses (4), put the parting marks on the hoses for marking proper reconnecting.

(When reassembling)

- Connect the heater hoses at their original positions.
- When connecting the heater hoses with A/C unit, the insert amount should do more than 10 mm (0.39 in.). For the other locations, the hose insert amount should be more than 20 mm (0.79 in.)

- | | |
|-----------------|-----------------|
| (1) Outer Roof | (4) Heater Hose |
| (2) Inner Roof | (5) Heater Pipe |
| (3) Inner Cover | |

9Y1211109CAS0073US0

(6) Cabin Windshields

Preparation

1. Prepare the followings.
 - Cutter knife: 1 piece
 - Scraper: 1 piece
 - Gun for coating: 1 piece
 - Sika Flex 250PC or equivalent
 - Gummed tape
 - Sika primer 206G + P or equivalent
 - Shin Etsu silicon KE420 or equivalent
 - Sika Aktivator or equivalent
 - Sika Coating Aktivator

NOTE

- Sika product are made by Sika Corporation.
- Shin Etsu silicon KE420 is made by Shin Etsu Polymer Corporation.
- These materials can't be provided by Kubota Corporation.
- Therefore, please find the local made equivalent materials in your country and use them when you need.

9Y1211109CAS0074US0

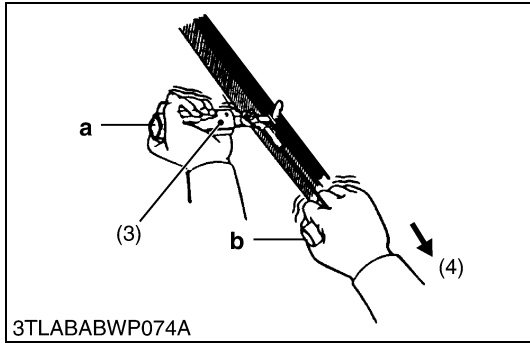
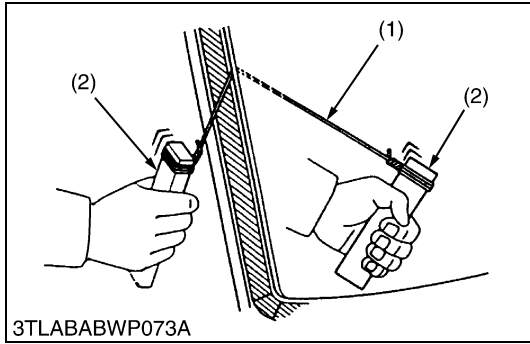

Before Replacing Windshields (1)

[In case of using piano wire (When glass is clacked)]

1. Thread the piano wire from the inside of cabin. Tie its both ends to a wooden blocks or the like. (See the left figure.)
2. Pull the piano wire inward/outward alternately to cut the adhered part.

■ **NOTE**

- Do not let the piano wire make sliding contact with the edge of glass plate forcibly.

[In case of using cutter knife (When glass is totally crushed finely)]

1. Insert the knife (3) into the adhered part.
2. Keep the edge of knife blade square to the glass edge at the part "a". Slide the knife blade along the glass surface and the edge. Pull the part "b" in the direction parallel to the glass edge to cut them off.

■ **NOTE**

- Find a wider gap between the glass and body.
- Be careful of handling the cutter knife not to damage your hand.

- | | |
|----------------|------------------|
| (1) Piano Wire | (3) Cutter Knife |
| (2) Wood Peace | (4) Pulling |

9Y1211109CAS0075US0

Before Replacing Windshields (2)

1. When the Sika Flex 250PC or equivalent attached to the cabin frame and the glass are reused, remove the bond clearly.

■ **NOTE**

- Remove the bond completely.

9Y1211109CAS0076US0

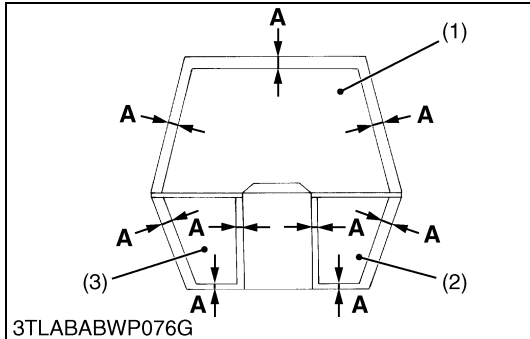

Before Replacing Windshields (3)

1. Check that the glasses are not damaged and cracked.
2. The cleaning area of the rear surface is indicated "A" in the figure left.

■ **NOTE**

- If not cleaning the glass, it may result in adhesive failure.

- | | |
|------------------------------|--|
| (1) Upper Windshield | A: 18 to 22 mm (0.71 to 0.87 in.) |
| (2) Lower Windshield (Left) | |
| (3) Lower Windshield (Right) | |

9Y1211109CAS0077US0

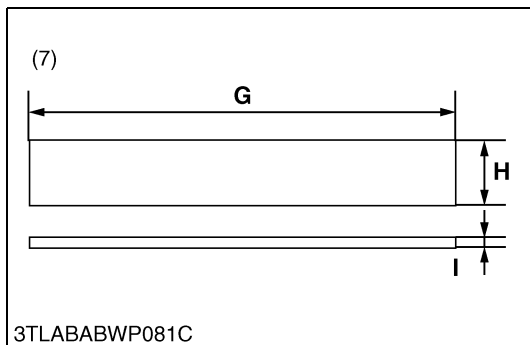
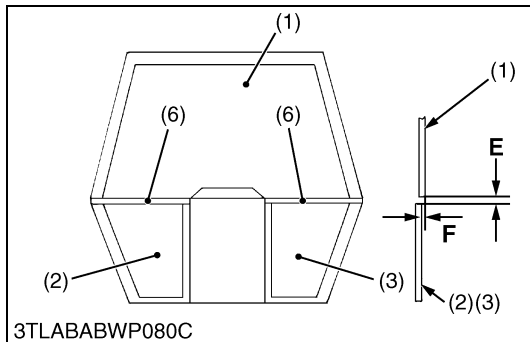
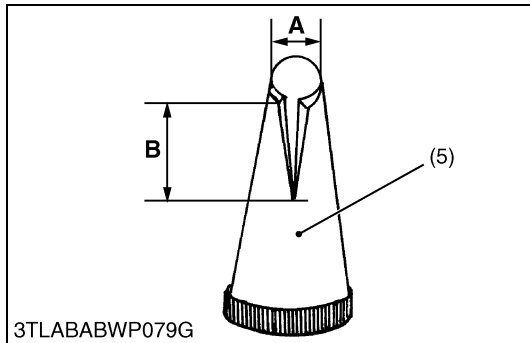
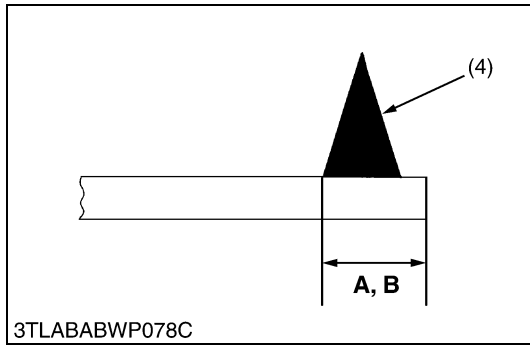
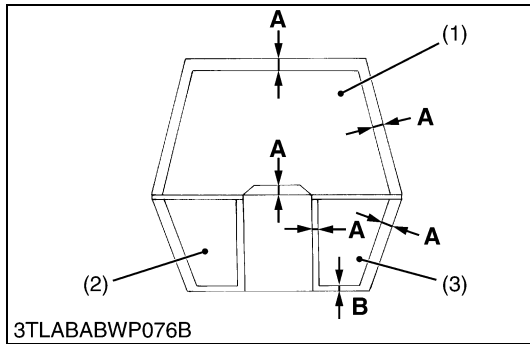

Front Windshield

■ **NOTE**

- Apply the Sika Flex 250PC (or equivalent) with the jig having the specified tip shape as shown in the figure left.
- Apply it with a uniform speed to minimize unevenness.
- Follow the instruction manual of Sika Flex 250PC.

1. Apply the Sika Primer 250PC on the cabin frame "A" and "B" in the figure.
2. Apply the Sika Flex 250PC (4) on the windshield "A" and "B" in the figure.
3. Install the lower (left or right) windshield to the cabin and fix it with a gummed tape.
4. Set the upper windshield to the cabin and fix it with a gummed tape.

■ **NOTE**

- Use a jig (7) shown in the figure to create even clearance "E" [approx. 5 mm (0.2 in.)] between the lower and upper windshield.
- The level unevenness between the upper and lower windshields should be -1 to +1 mm (-0.04 to +0.04 in.) or less at the windshield surface.

5. Leave it for one hour.
6. Remove the jig (7).
7. Install the H rubber (6) between the lower and upper windshield (2), (3).
8. Apply the Shin Etsu silicon KE420 in H rubber (6).
9. Apply the Shin Etsu silicon KE420 on the edge of H rubber (6).

■ **NOTE**

- When the gummed tape is removed, the glass may be displaced. In this case fix it again.
- Remove the gummed tape (adhesive tape) little by little to make sure the bonding condition.

- (1) Upper Windshield
- (2) Lower Windshield (Right)
- (3) Lower Windshield (Left)
- (4) Sika Flex 250PC
- (5) Jig
- (6) H Rubber
- (7) Jig

- A: 10 mm (0.39 in.)
- B: 12 mm (0.47 in.)
- C: 8 mm dia. (0.31 in. dia.)
- D: 12 mm (0.47 in.)
- E: 5 mm (0.2 in.)
- F: -1.0 to +1.0 mm (-0.04 to +0.04 in.)
- G: 360 mm (14.2 in.)
- H: 20 mm (0.8 in.)
- I: 5 mm (0.2 in.)

9Y1211109CAS0078US0

(7) Wiper Motor

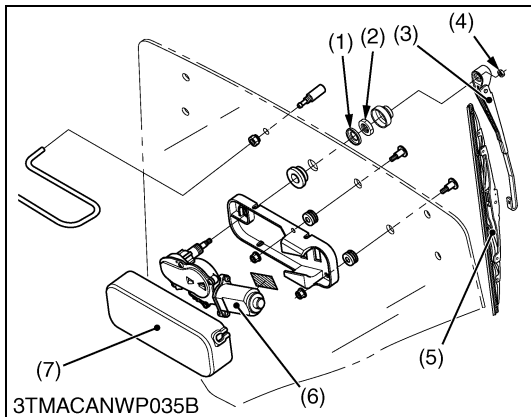
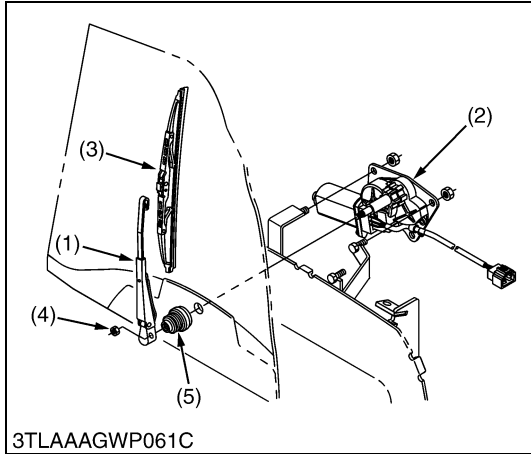
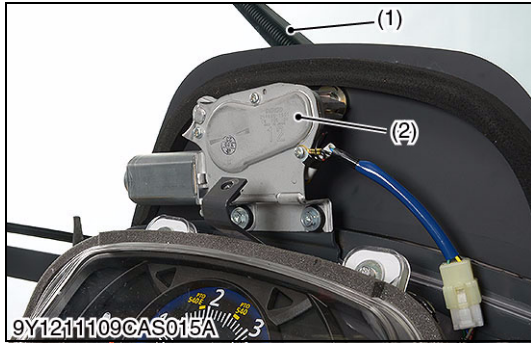

Wiper Motor

1. Remove the panel cover.
2. Disconnect the front wiper motor **4P** connector.
3. Remove the wiper arm mounting nut (4) and wiper arm (1).
4. Remove the wiper link cap (5).
5. Remove the front wiper motor (2).

(When reassembling)

- When attaching the wiper arm (1) to the wiper motor (2), assemble so that the dimensions are as given in the photo on the left. After doing so, check if the wiper wipes symmetrically on the left and right (bilateral symmetry).

Tightening torque	Wiper arm mounting nut	7.9 to 9.8 N·m 0.80 to 1.0 kgf·m 5.8 to 7.2 lbf·ft
	Wiper motor mounting screw	3.4 to 6.4 N·m 0.35 to 0.65 kgf·m 2.5 to 4.7 lbf·ft

- | | |
|-----------------------|--------------------|
| (1) Wiper Arm | (4) Nut |
| (2) Front Wiper Motor | (5) Wiper Link Cap |
| (3) Wiper Blade | |

9Y1211109CAS0079US0

Rear Wiper Motor (If equipped)

1. Remove the wiper motor cover (7).
2. Disconnect the **4P** connector from rear wiper motor (6).
3. Remove the wiper arm mounting nut (4) and wiper arm (3).
4. Remove the wiper link cap (1) and nut (2).
5. Remove the rear wiper motor mounting screws and the rear wiper motor (6).

Tightening torque	Wiper arm mounting nut	7.9 to 9.8 N·m 0.80 to 1.0 kgf·m 5.8 to 7.2 lbf·ft
	Wiper motor mounting screw	3.4 to 6.4 N·m 0.35 to 0.65 kgf·m 2.5 to 4.7 lbf·ft

- | | |
|--------------------|-----------------------|
| (1) Wiper Link Cap | (5) Wiper Blade |
| (2) Nut | (6) Rear Wiper Motor |
| (3) Wiper Arm | (7) Wiper Motor Cover |
| (4) Nut | |

9Y1211109CAS0080US0

[3] SERVICING

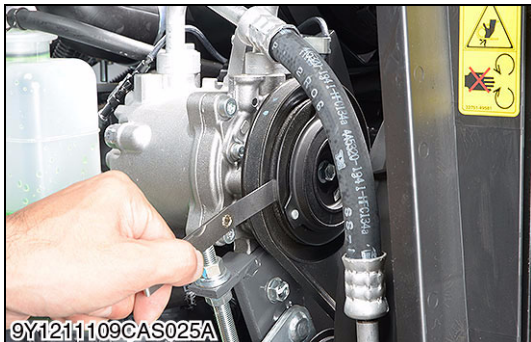
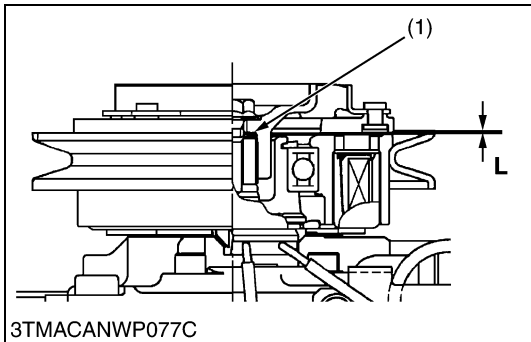

Adjustment of Air Gap

1. Measure the air gap with a feeler gauge.
2. When the measurement value comes off from factory specification, adjustment shim (1) is added or deleted.

Air gap "L"	Factory specification	0.30 to 0.65 mm 0.012 to 0.025 in.
-------------	-----------------------	---------------------------------------

(Reference)

Adjusting Shim Size	Code No.
0.10 mm (0.0039 in.)	T1065-87340
0.15 mm (0.0059 in.)	T1065-87350
0.40 mm (0.016 in.)	T1065-87360
0.60 mm (0.024 in.)	T1065-87370
1.00 mm (0.0394 in.)	T1065-87380

(1) Shim

L: Air Gap

9Y1211109CAS0081US0

EDITOR:

KUBOTA FARM & INDUSTRIAL MACHINERY SERVICE, LTD.

64, ISHIZU-KITAMACHI, SAKAI-KU, SAKAI-CITY, OSAKA, 590-0823, JAPAN

PHONE : (81)72-241-1129

FAX : (81)72-245-2484

E-mail : ks_g.ksos-pub@kubota.com
