

Instructions for Parts Books

The heading at the top of the page will be the same for the picture of the parts at it is for the page with the part numbers.

Definition of column headings on part number pages:

REF.No → The number referring to the part on the picture page of the parts book.

Part No. → The number assigned to this part at the time of printing the parts book.

Description → Discription of part.

Q'ty → Quantity of part used on that page.

S.No. → Serial number range of the equipment that this part will fit.

>= Your serial number should be greater than or equal to the number shown.

<= Your serial number should be lesser than or equal to the serial number shown.

I/C → Interchangeability of part shown.

↔ The part shown will work for the older and later serial number.

The part shown is not interchangeable with the other serial number.

← new for old

→ old for new

Remarks → Notes about this particulart part. Sometimes this may say except [FR] or [CA]

Note about Country Codes:

The parts books we use in the United States of America may also contain information about a part that would be different in another country. It is important that you are aware of the country codes in some instances.

Symbol	Country
A	United States of America
CA	Canada
FR	France
GR	Greece
PO	Portugal
AU	Australia

If the remarks column says for example EXCEPT [FR] this part works in all countries except France. That means it will work here in the USA.

ALL PRODUCT INDEX
L35

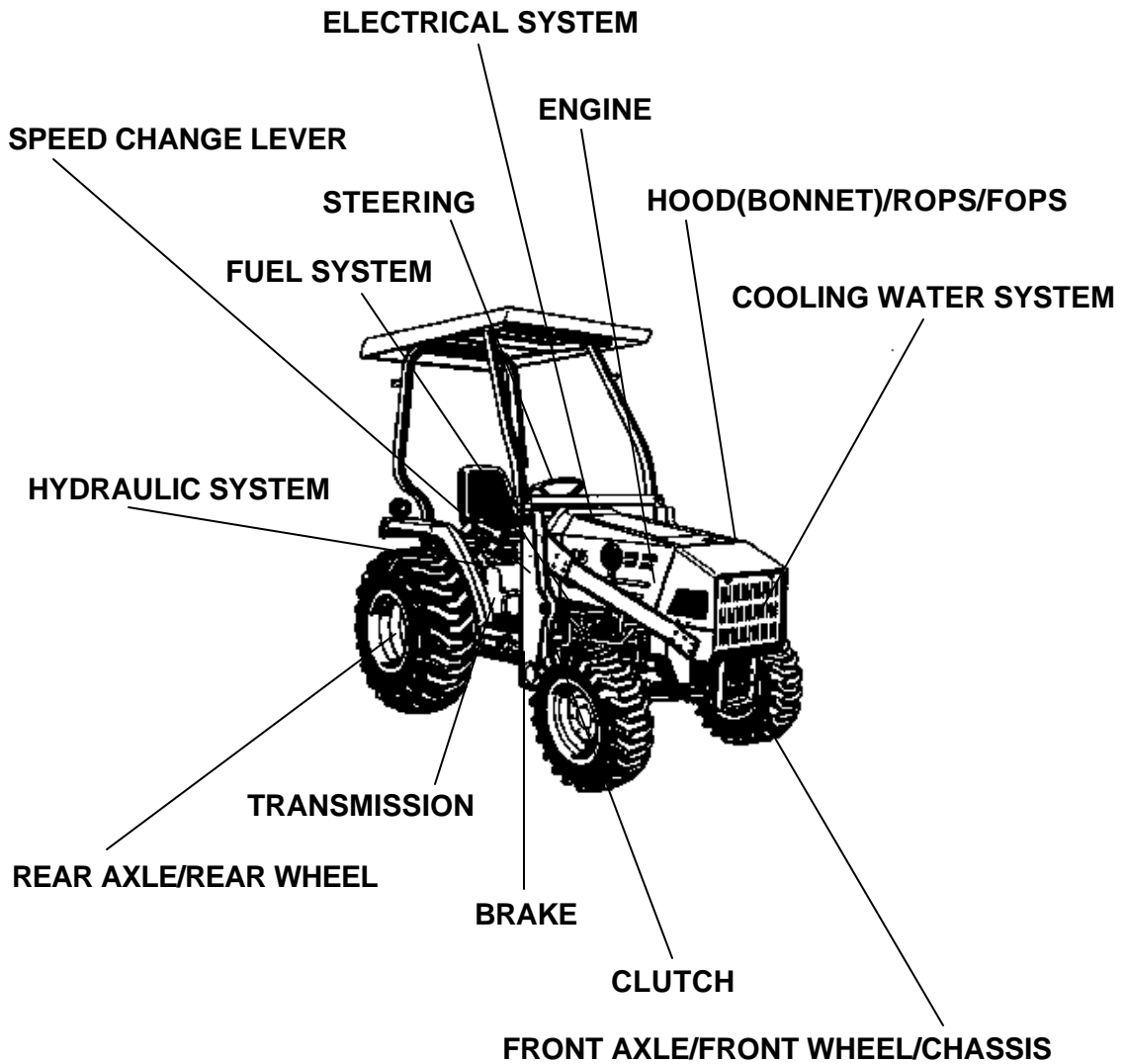

LABELS

ACCESSORIES

Item	Part No.	Description	Book	
ENGINE	01T001	CRANKCASE	100K0361	
	01T002	OIL PAN	100K0361	
	01T003	PISTON AND CRANKSHAFT	100K0361	
	01T004	MAIN BEARING CASE [OLD TYPE]	100K0361	
	01T00401	MAIN BEARING CASE [NEW TYPE]	100K0361	
	01T005	FLYWHEEL	100K0361	
	01T006	CYLINDER HEAD	100K0361	
	01T007	VALVE AND ROCKER ARM [OLD TYPE]	100K0361	
	01T00701	VALVE AND ROCKER ARM [NEW TYPE]	100K0361	
	01T008	NOZZLE HOLDER AND GLOW PLUG	100K0361	
	01T009	NOZZLE HOLDER [COMPONENT PARTS]	100K0361	
	01T010	CYLINDER HEAD COVER [OLD TYPE]	100K0361	
	01T01001	CYLINDER HEAD COVER [NEW TYPE]	100K0361	
	01T011	INLET MANIFOLD	100K0361	
	02T012	AIR CLEANER	100K0361	
	02T013	EXHAUST MANIFOLD AND MUFFLER	100K0361	
	01T014	CAMSHAFT	100K0361	
	01T015	GEAR CASE	100K0361	
	01T016	WATER PUMP	100K0361	
	01T017	WATER FLANGE AND THERMOSTAT	100K0361	
	01T018	FUEL CAMSHAFT	100K0361	
	01T019	INJECTION PUMP	100K0361	
	01T021	ENGINE STOP LEVER	100K0361	
	01T022	SPEED CONTROL PLATE	100K0361	
	01T023	GOVERNOR	100K0361	
	01T024	UPPER GASKET KIT	100K0361	
	01T025	LOWER GASKET KIT	100K0361	
	02T026	STOP SELENOID AND ENGINE STOP WIRE	100K0361	
	02T027	ACCELERATOR LEVER	100K0361	
	02T028	ACCELERATOR LINKAGE	100K0361	
	02T029	ACCELERATOR ROD	100K0361	
	FUEL SYSTEM	02T030	FUEL TANK	100K0361
		02T031	FUEL FILTER AND FUEL PIPE	100K0361
		02T032	FUEL FILTER [COMPONENT PARTS]	100K0361
	COOLING WATER SYSTEM	02T033	FAN	100K0361
		02T034	WATER PIPE	100K0361
		02T035	RADIATOR	100K0361
		02T036	RESERVE TANK	100K0361
	ELECTRICAL SYSTEM	02T037	ALTERNATOR	100K0361
		02T038	ALTERNATOR [COMPONENT PARTS]	100K0361
		02T039	STARTER	100K0361
		02T040	STARTER [COMPONENT PARTS]	100K0361
		02T041	BATTERY	100K0361
		02T042	SWITCH	100K0361
		02T043	PANEL BOARD	100K0361
		02T044	PANEL BOARD [COMPONENT PARTS]	100K0361
		02T045	LIGHT [OLD TYPE]	100K0361
		02T04501	LIGHT [NEW TYPE]	100K0361
02T046	ELECTRICAL WIRING [OLD TYPE]	100K0361		
02T04601	ELECTRICAL WIRING [NEW TYPE]	100K0361		
CLUTCH	02T047	CLUTCH	100K0361	
	02T048	CLUTCH LEVER	100K0361	

Item	Part No.	Description	Book	
CLUTCH	02T049	CLUTCH PEDAL	100K0361	
	02T050	CLUTCH HOUSING	100K0361	
	02T051	MID CASE	100K0361	
TRANSMISSION	02T052	TRANSMISSION CASE	100K0361	
	02T053	MAIN SHAFT	100K0361	
	02T054	COUNTERSHAFT	100K0361	
	02T055	HYDRAULIC CLUTCH	100K0361	
	02T056	SHUTTLE SHAFT	100K0361	
	02T057	RANGE GEAR SHAFT	100K0361	
	02T058	PTO COUNTERSHAFT AND ONE WAY CLUTCH	100K0361	
	02T059	PTO SHAFT	100K0361	
SPEED CHANGE LEVER	02T060	MAIN GEAR SHIFT LEVER	100K0361	
	02T06001	GST SHIFT COVER [OPTION]	100K0361	
	02T061	MAIN GEAR SHIFT FORK	100K0361	
	02T062	SHUTTLE GEAR SHIFT LEVER	100K0361	
	02T063	SHUTTLE GEAR SHIFT FORK	100K0361	
	02T064	RANGE GEAR SHIFT FORK	100K0361	
	02T065	PTO GEAR SHIFT LEVER	100K0361	
	02T066	PTO GEAR SHIFT FORK	100K0361	
	02T067	SPIRAL BEVEL PINION	100K0361	
	02T068	REAR DIFFERENTIAL	100K0361	
REAR AXLE/REAR WHEEL	02T069	DEFFERENTIAL LOCK SHIFT FORK	100K0361	
	02T070	REAR AXLE	100K0361	
BRAKE	02T071	REAR WHEEL (15-19.5)	100K0361	
	02T072	BRAKE	100K0361	
	02T073	BRAKE PEDAL	100K0361	
FRONT AXLE/FRONT WHEEL/CHASSIS	02T074	BRAKE ROD	100K0361	
	02T075	FRONT AXLE	100K0361	
	02T076	FRONT AXLE CASE	100K0361	
	02T077	DIFFERENTIAL GEAR SHAFT	100K0361	
	02T078	FRONT DIFFERENTIAL CASE	100K0361	
	02T079	FRONT DIFFERENTIAL	100K0361	
	02T080	PROPELLER SHAFT	100K0361	
	02T081	FRONT WHEEL DRIVE SHAFT	100K0361	
	02T082	FRONT WHEEL DRIVE LEVER	100K0361	
	02T083	FRONT WHEEL (27X10.5-15)	100K0361	
	02T084	FRONT AXLE FRAME	100K0361	
	STEERING	02T085	STEERING LINKAGE	100K0361
		02T086	STEERING CYLINDER	100K0361
		02T087	STEERING CYLINDER [COMPONENT PARTS]	100K0361
		02T088	STEERING CONTROLLER	100K0361
	HYDRAULIC SYSTEM	02T089	STEERING HANDLE	100K0361
		02T090	HYDRAULIC OIL LINE (PS)	100K0361
02T091		GST VALVE	100K0361	
02T09101		GST VALVE [GST TYPE] [COMPONENT PARTS]	100K0361	
02T09102		GST VALVE [GST TYPE] [COMPONENT PARTS]	100K0361	
02T09103		GST VALVE [GST TYPE] [COMPONENT PARTS]	100K0361	
02T092		REGULATOR VALVE	100K0361	

Item	Part No.	Description	Book	
HYDRAULIC SYSTEM	02T093	HYDRAULIC PUMP	100K0361	
	02T094	HYDRAULIC PUMP [COMPONENT PARTS]	100K0361	
	02T095	HYDRAULIC PUMP	100K0361	
	02T096	HYDRAULIC PUMP [COMPONENT PARTS]	100K0361	
	02T097	HYDRAULIC OIL LINE (INLET)	100K0361	
	02T098	HYDRAULIC OIL LINE (DELIVERY)	100K0361	
	02T099	HYDRAULIC CYLINDER	100K0361	
	02T100	LIFT ARM	100K0361	
	02T101	CONTROL VALVE	100K0361	
	02T102	CONTROL VALVE [COMPONENT PARTS]	100K0361	
	02T103	POSITION CONTROL LEVER	100K0361	
	02T104	FEED BACK LEVER	100K0361	
	02T105	DIRECTIONAL VALVE LEVER	100K0361	
	02T106	3-POINT LINKAGE 1 (LOWER LINK)	100K0361	
	02T107	3-POINT LINKAGE 2 (LIFT ROD)	100K0361	
	02T108	TOP LINK HOLDER AND PTO PROTECTOR	100K0361	
	HOOD(BONNET)/ROPS/FOPS	02T109	FRONT GRILLE	100K0361
		02T110	HOOD (BONNET) AND SIDE COVER	100K0361
02T111		SHUTTER PLATE	100K0361	
02T112		PANEL FRAME	100K0361	
02T113		FENDER	100K0361	
02T114		FLOOR SEAT	100K0361	
02T115		SEAT	100K0361	
02T116		REVERSIBLE SEAT BASE [COMPONENT PARTS]	100K0361	
02T117		STEP	100K0361	
02T118		MAIN FRAME	100K0361	
LABELS	02T119	ROPS AND FOPS	100K0361	
	02T120	LABEL 1	100K0361	
ACCESSORIES	02T121	LABEL 2	100K0361	
	02T122	ACCESSORIES AND SERVICE PARTS	100K0361	

CRANKCASE

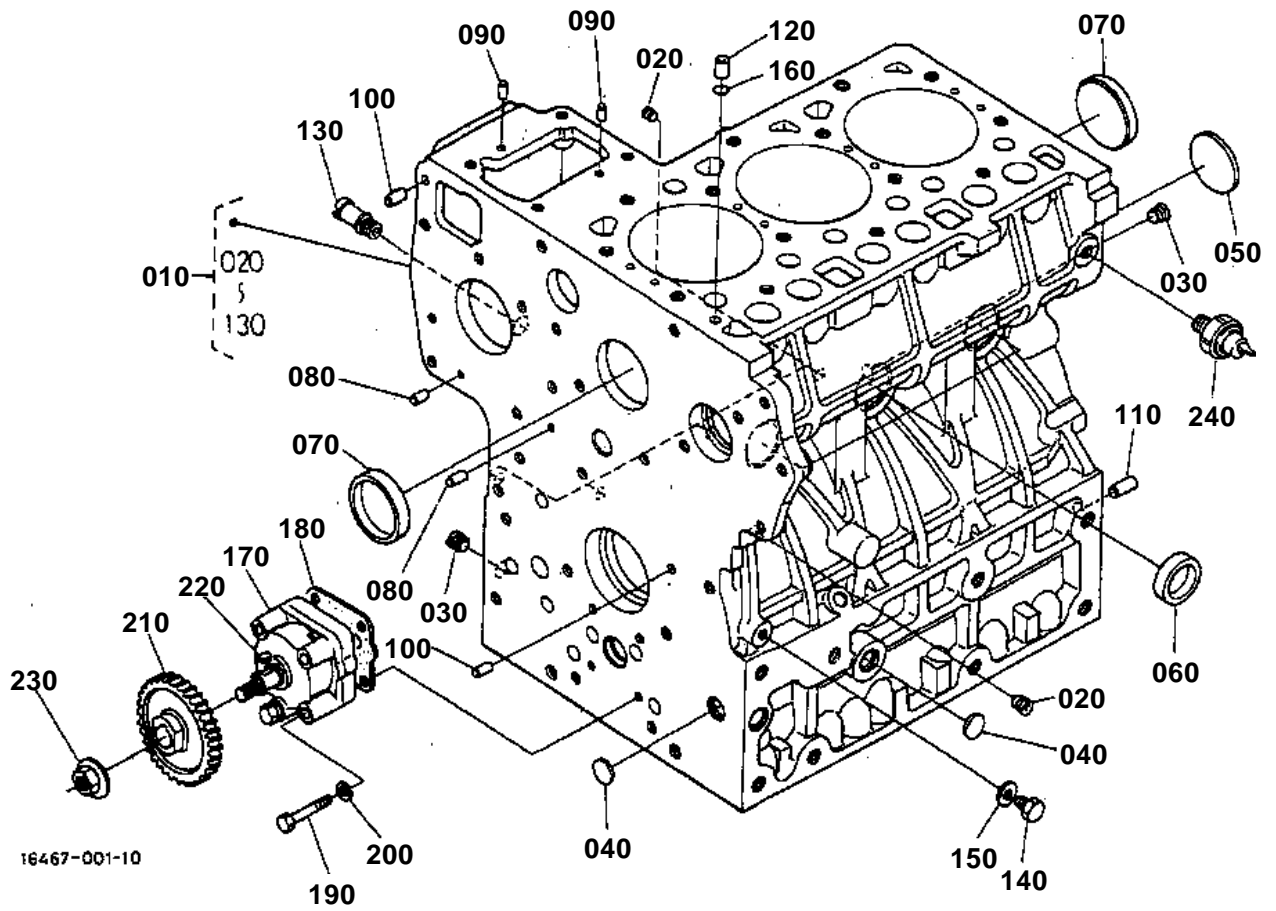



CRANKCASE

↔ Interchangeable; ≠ not interchangeable; ← new for old; → old for new

REF.No	Part No.	Description	Q'ty	S.No.	I/C	REMARKS	Weight (kgf)	Weight (lb)
010	16487-01010	COMP.CRANKCASE	1	<=1Y0497			48.5	106.7
010	16487-01016	COMP.CRANKCASE	1	>=2A0001	→		48.5	106.7
010	16487-01017	COMP.CRANKCASE	1	>=3S0001	1		54	118.8
020	15521-96020	PLUG	5				0.003	0.0066
030	15521-96030	PLUG	2				0.007	0.0154
040	17391-96160	PLUG	3				0.003	0.0066
050	06311-75045	PLUG	1	<=3G0450			0.026	0.0572
050	16271-96160	PLUG EXPANSION	1	>=3J0001	1		0.025	0.055
060	15221-03380	CAP SEALING	5				0.017	0.0374
070	15221-03390	CAP SEALING	2				0.03	0.066
080	05012-00408	PIN STRAIGHT	2				0.001	0.0022
090	05012-00609	PIN STRAIGHT	2				0.003	0.0066
100	05012-00612	PIN STRAIGHT	2				0.003	0.0066
110	05012-01018	PIN STRAIGHT	1				0.012	0.0264
120	15221-33650	PIN PIPE	1				0.004	0.0088
130	15321-73340	PIPE WATER RETURN	1				0.016	0.0352
140	15221-33610	PLUG	1				0.009	0.0198
150	15021-33660	GASKET	1				0.001	0.0022
160	15221-33700	O RING	1				0.001	0.0022
170	15471-35010	ASSY PUMP OIL	1				0	0
170	15471-35012	ASSY PUMP OIL	1		←		0.55	1.21
180	15296-35150	GASKET OIL PUMP	1				0	0
180	1A021-35150	GASKET OIL PUMP	1		←		0.001	0.0022
190	01053-50650	BOLT	4				0.011	0.0242
200	04512-50060	WASHER SPRING	4				0	0
210	19202-35660	GEAR OIL PUMP DRIVE	1				0.23	0.506
220	05712-00410	KEY FEATHER	1				0.001	0.0022
230	15221-35682	NUT FLANGE	1				0.014	0.0308
240	15531-39010	SWITCH OIL	1				0.032	0.0704

OIL PAN

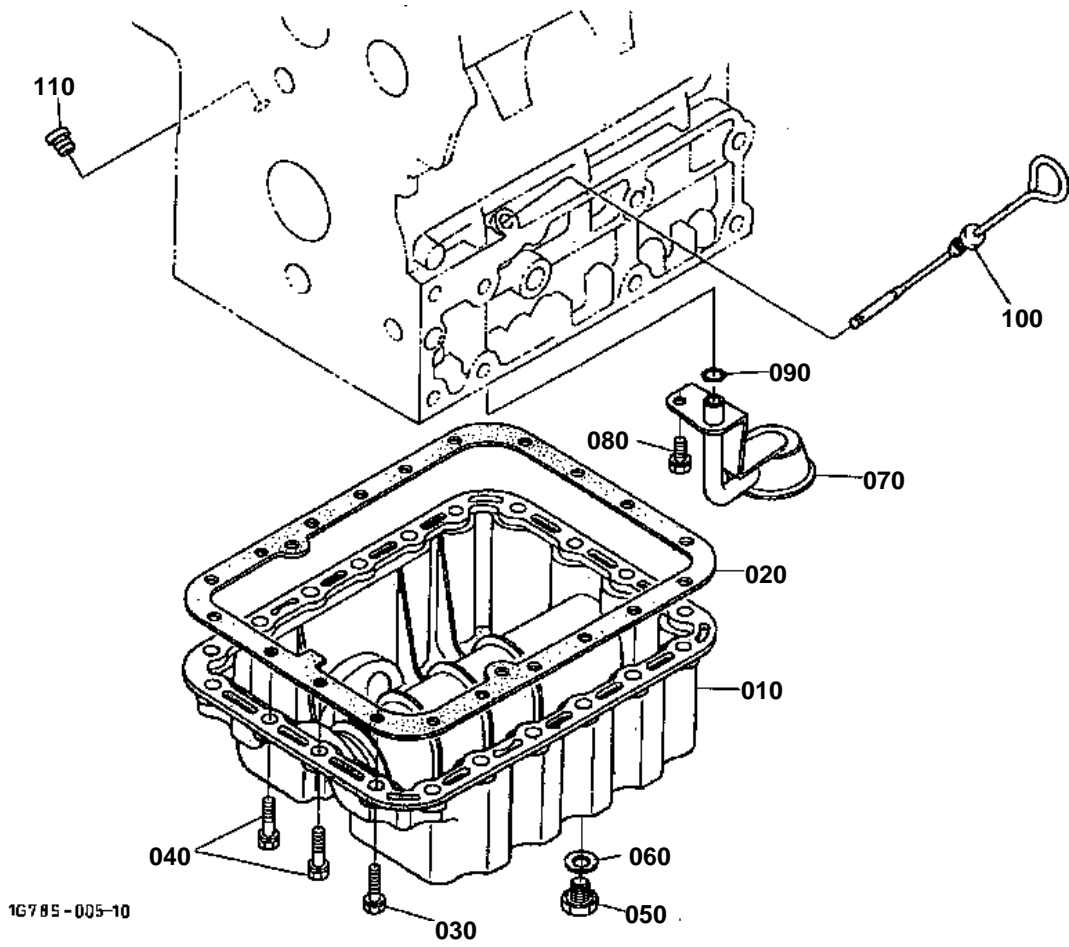

020 17326-0162-0

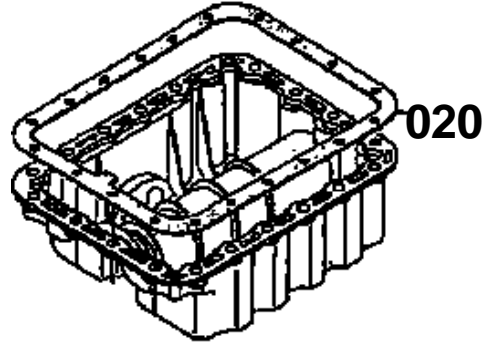

16467-813-20



OIL PAN

↔ Interchangeable; ≠ not interchangeable; ← new for old; → old for new

REF.No	Part No.	Description	Q'ty	S.No.	I/C	REMARKS	Weight (kgf)	Weight (lb)
010	15521-01610	OIL PAN	1				2.8	6.16
020	17326-01620	GASKET OIL PAN	1				0	0
020	1A021-01620	GASKET OIL PAN	1		«		0.014	0.0308
030	01133-51028	BOLT	18				0.027	0.0594
040	01133-51025	BOLT	2				0.023	0.0506
050	15261-33750	PLUG	2	<=YJ0586			0.034	0.0748
050	16427-33750	PLUG	2	>=YL0001	—		0.03	0.066
060	15109-33660	GASKET	2				0.001	0.0022
060	6C090-58960	GASKET	2		«		0.002	0.0044
070	16427-32110	FILTER OIL	1				0.2	0.44
080	01123-50814	BOLT	1				0	0
090	04811-00160	O RING	1				0	0
090	04816-00160	O RING	1		«		0.003	0.0066
100	16427-36410	GAUGE OIL	1				0.035	0.077
110	16414-33640	PLUG OIL GAUGE	1	>=2A0001			0	0

PISTON AND CRANKSHAFT

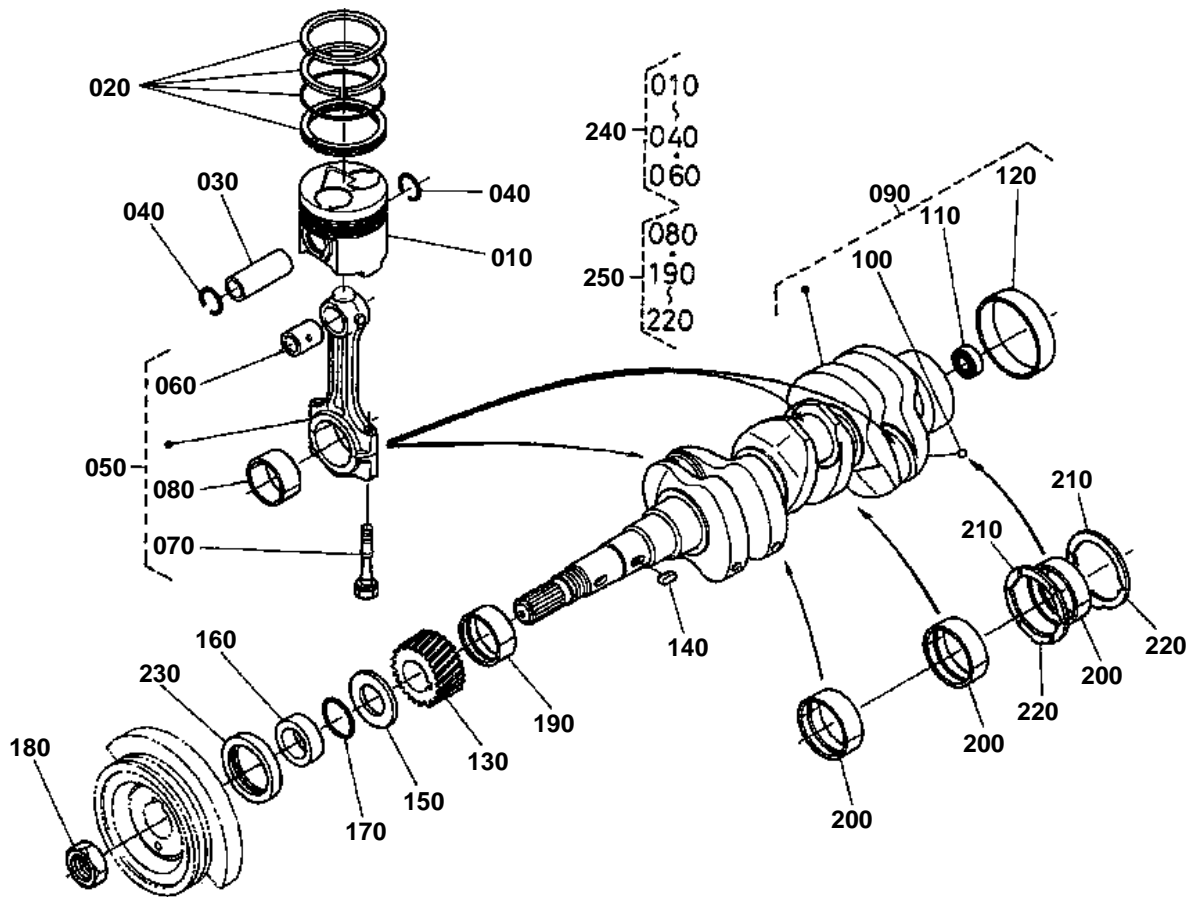

16477-001-12

OLD PARTS

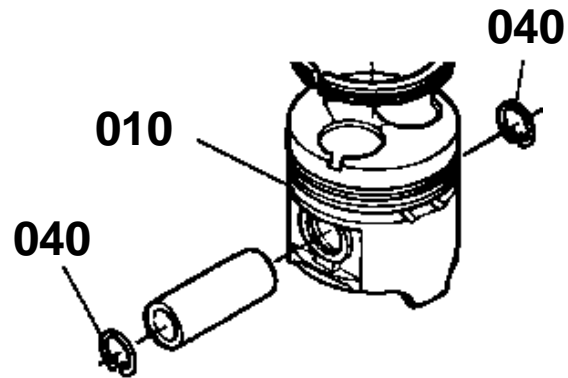

1G726-805-10



PISTON AND CRANKSHAFT

NOTE:ORDER BY REF.No.010 and 040 NEW PART.

↔ Interchangeable; ≠ not interchangeable; ← new for old; → old for new

REF.No	Part No.	Description	Q'ty	S.No.	I/C	REMARKS	Weight (kgf)	Weight (lb)
010	19077-21110	PISTON	3	←=4N1454		STD NOT SALE SEE NOTE	0.58	1.276
010	19077-21112	PISTON	3	>=4Q0001	1	STD	0.58	1.276
010	19077-21910	PISTON	3	←=4N1454		+0.50mm SEE NOTE	0.585	1.287
010	19077-21912	PISTON	3	>=4Q0001	1	+0.50mm	0.585	1.287
020	17331-21050	ASSY PISTON RING	3			STD	0.065	0.143
020	17331-21090	ASSY PISTON RING	3			+0.50mm	0.065	0.143
030	14901-21310	PIN PISTON	3				0.17	0.374
040	14109-21330	CLIP PISTON PIN	6	←=4N1454			0.001	0.0022
040	1G279-21330	CIR CLIP INTERNAL	6	>=4Q0001	1		0.001	0.0022
050	17311-22010	ASSY CONNECTING ROD	3				0.885	1.947
060	17331-21980	BUSH PISTON PIN	3				0.025	0.055
070	15521-22142	BOLT CONNECTING ROD	6				0.026	0.0572
080	17311-22310	METAL CRANKPIN	3			STD	0.045	0.099
080	17331-22970	METAL CRANKPIN	3			-0.20mm	0	0
080	17331-22980	METAL CRANKPIN	3			-0.40mm	0.045	0.099
090	16467-23010	COMP.CRANKSHAFT	1	←=3Q0483			13	28.6
090	16467-23013	COMP.CRANKSHAFT	1	>=3S0001	1		13	28.6
100	07715-00401	BALL	3				0.001	0.0022
110	08121-06002	BEARING BALL	1				0.03	0.066
120	19202-23280	SLEEVE CRANKSHAFT	1				0.09	0.198
130	15471-24110	GEAR CRANKSHAFT	1				0.375	0.825
140	05712-00720	KEY FEATHER	1				0.008	0.0176
150	15471-23312	SLINGER OIL	1				0.008	0.0176
160	19202-23250	COLLAR CRANKSHAFT	1				0.065	0.143
170	04811-10300	O RING	1				0.001	0.0022
180	15221-23360	NUT CRANKSHAFT	1				0.11	0.242
190	17311-23470	METAL CRANKSHAFT	1	←=YA0300		STD	0	0
190	17311-23472	METAL CRANKSHAFT	1	>=YA0301	┘	STD	0.06	0.132
190	1A091-23470	METAL CRANKSHAFT	1	>=3S0001	1	STD	0.062	0.1364
190	17311-23910	METAL CRANKSHAFT	1	←=3Q0483		-0.20mm	0.05	0.11
190	1A091-23910	METAL CRANKSHAFT	1	>=3S0001	1	-0.20mm	0.065	0.143
190	17311-23920	METAL CRANKSHAFT	1	←=3Q0483		-0.40mm	0.06	0.132
190	1A091-23920	METAL CRANKSHAFT	1	>=3S0001	1	-0.40mm	0.065	0.143
200	17311-23480	METAL CRANKSHAFT	3	←=3Q0483		STD	0.045	0.099
200	1A091-23480	METAL CRANKSHAFT	3	>=3S0001	1	STD	0.05	0.11
200	17311-23930	METAL CRANKSHAFT	3	←=3Q0483		-0.20mm	0.05	0.11
200	1A091-23930	METAL CRANKSHAFT	3	>=3S0001	1	-0.20mm	0.06	0.132
200	17311-23940	METAL CRANKSHAFT	3	←=3Q0483		-0.40mm	0.06	0.132
200	1A091-23940	METAL CRANKSHAFT	3	>=3S0001	1	-0.40mm	0.065	0.143
210	15521-23530	METAL SIDE	2	←=3Q0483		STD	0.01	0.022
210	1A091-23530	METAL SIDE	2	>=3S0001	1	STD	0.009	0.0198
210	15521-23950	METAL SIDE	2	←=YE0248		+0.20mm	0	0
210	15521-23950	METAL SIDE	2	>=YE0249	┘	+0.20mm	0.01	0.022
210	1A091-23950	METAL SIDE	2	>=3S0001	1	+0.20mm	0.005	0.011
210	15521-23960	METAL SIDE	2	←=YE0248		+0.40mm	0	0
210	15521-23960	METAL SIDE	2	>=YE0249	┘	+0.40mm	0.01	0.022
210	1A091-23960	METAL SIDE	2	>=3S0001	1	+0.40mm	0.005	0.011
220	19202-23540	METAL SIDE	2	←=3Q0483		STD	0.01	0.022

**PISTON AND CRANKSHAFT**

NOTE:ORDER BY REF.No.010 and 040 NEW PART.

↔ Interchangeable; ≠ not interchangeable; ← new for old; → old for new

REF.No	Part No.	Description	Q'ty	S.No.	I/C	REMARKS	Weight (kgf)	Weight (lb)
220	1A091-23540	METAL SIDE	2	>=3S0001	1	STD	0.009	0.0198
220	19202-23970	METAL SIDE	2	<=3Q0483		+0.20mm	0.01	0.022
220	1A091-23970	METAL SIDE	2	>=3S0001	1	+0.20mm	0.005	0.011
220	19202-23980	METAL SIDE	2	<=3Q0483		+0.40mm	0.01	0.022
220	1A091-23980	METAL SIDE	2	>=3S0001	1	+0.40mm	0.005	0.011
230	19202-04140	SEAL OIL	1				0.015	0.033
240	07916-26940	KIT PISTON-RING	3			STD	0.87	1.914
240	07916-26950	KIT PISTON-RING	3			+0.50mm	0.68	1.496
250	07916-28070	KIT METAL ENGINE	1			STD	0.35	0.77
250	07916-28720	KIT METAL ENGINE	1			-0.20mm	0	0
250	07916-28722	KIT METAL ENGINE	1		↔	-0.20mm	0.44	0.968
250	07916-28730	KIT METAL ENGINE	1			-0.40mm	0	0
250	07916-28732	KIT METAL ENGINE	1		↔	-0.40mm	0.44	0.968

MAIN BEARING CASE [OLD TYPE]

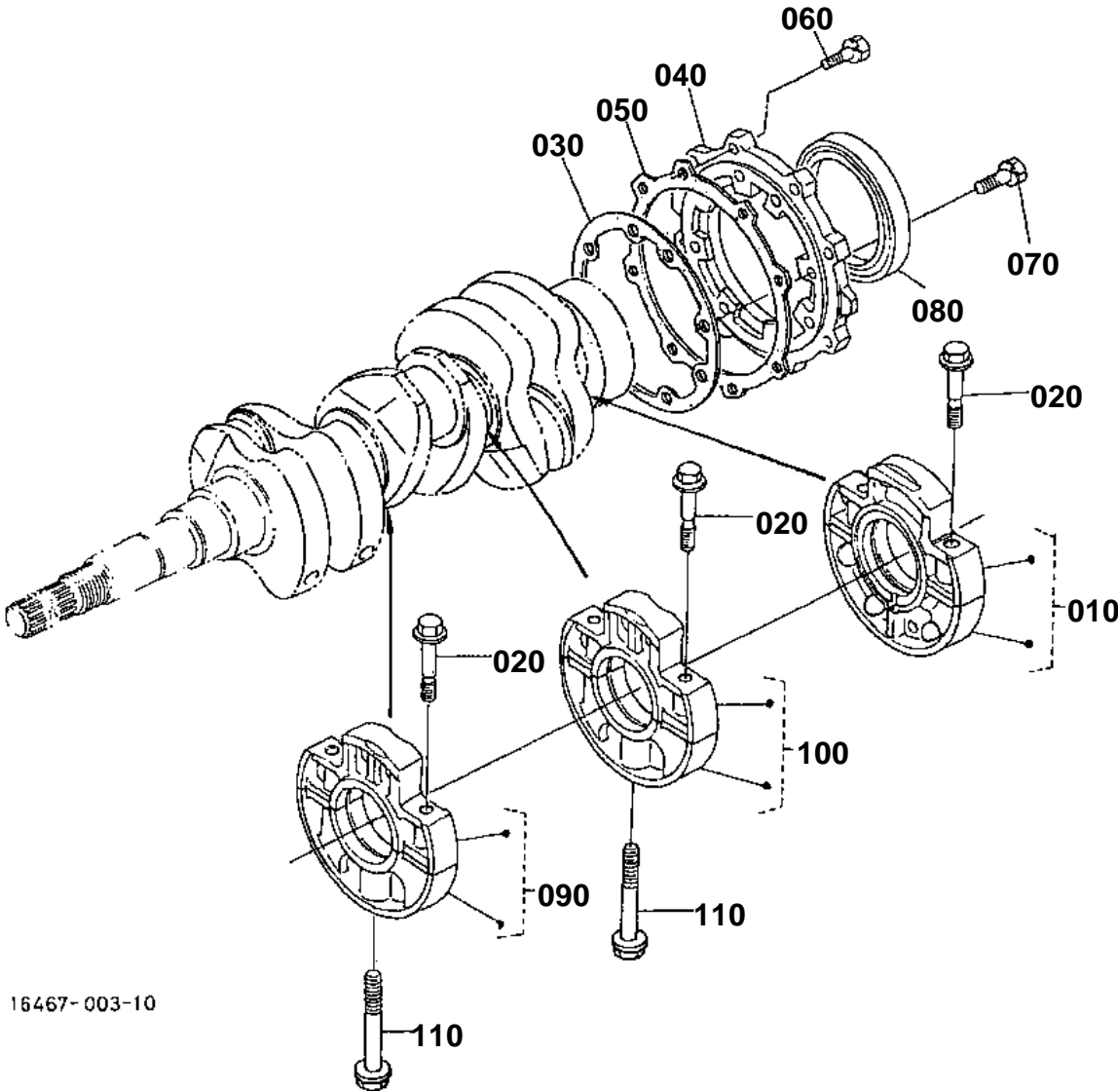

16467-003-10

**MAIN BEARING CASE [OLD TYPE]**

S.No.;<=9369

↔ Interchangeable; ≠ not interchangeable; ← new for old; → old for new

REF.No	Part No.	Description	Q'ty	S.No.	I/C	REMARKS	Weight (kgf)	Weight (lb)
010	19013-04090	ASSY BRG.CASE WHEEL	1				0	0
020	19013-04540	BOLT BEARING CASE	6				0.038	0.0836
030	17118-04360	GASKET BEARING CASE	1				0	0
030	19077-04360	GASKET BEARING CASE	1		«		0	0
040	19013-04813	COVER BEARING CASE	1				0	0
050	17118-04830	GASKET CASE COVER	1				0	0
060	01123-50828	BOLT	8				0.014	0.0308
070	01123-50828	BOLT	8				0.014	0.0308
080	19202-04460	SEAL OIL	1				0.055	0.121
090	19013-04040	ASSY BRG.CASE MAIN	1				0	0
100	19013-04050	ASSY BRG.CASE MAIN	1				0	0
110	15601-04560	BOLT BEARING CASE	2				0.06	0.132

MAIN BEARING CASE [NEW TYPE]

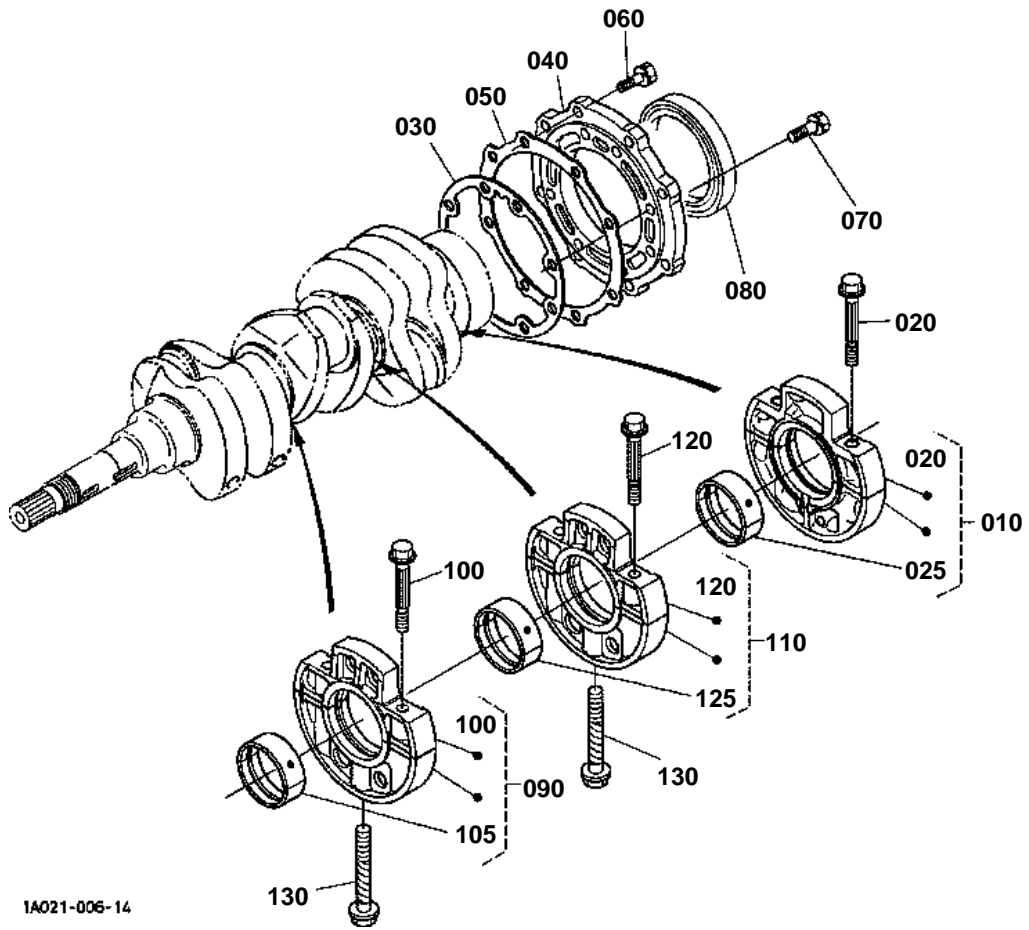

- 010 19013-0709-0
- 010 1A041-0709-2
- 020 19013-0454-0
- 030 19077-0436-0
- 040 19013-0481-3
- 090 19013-0704-0
- 090 1A091-0704-2
- 100 19013-0454-0
- 110 19013-0705-0
- 110 1A091-0705-2
- 120 19013-0454-0

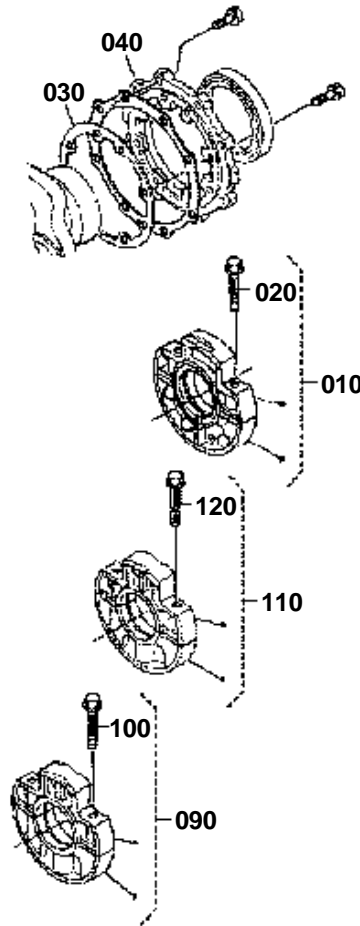

1A013-804-10

**MAIN BEARING CASE [NEW TYPE]**

S.No.;>=9370

↔ Interchangeable; ≠ not interchangeable; ← new for old; → old for new

REF.No	Part No.	Description	Q'ty	S.No.	I/C	REMARKS	Weight (kgf)	Weight (lb)
010	19013-07090	ASSY BRG.CASE WHEEL	1	<=3Q0483			1.55	3.41
010	1A041-07092	ASSY BRG.CASE WHEEL	1	>=3S0001	1		0	0
010	1A041-07093	ASSY BRG.CASE WHEEL	1	>=3U0001	-		1.34	2.948
020	19013-04540	BOLT BEARING CASE	2	<=3Q0483			0.038	0.0836
020	1A091-04540	BOLT BEARING CASE	2	>=3S0001	1		0.035	0.077
025	1A091-23480	METAL CRANKSHAFT	1	>=3U0001		STD SET	0.05	0.11
030	19077-04360	GASKET BRG.CASE	1	<=2Y0733			0	0
030	1A091-04362	GASKET BEARING CASE	1	>=3A0001	-		0.005	0.011
040	19013-04813	COVER BEARING CASE	1	<=3Q0483			0	0
040	1G851-04810	COVER BEARING CASE	1	>=3S0001	-		0.495	1.089
050	17118-04830	GASKET CASE COVER	1				0	0
050	1A091-04820	GASKET BRG.CASE COV.	1		«		0.006	0.0132
060	01123-50825	BOLT	8				0.013	0.0286
070	01123-50828	BOLT	8				0.014	0.0308
080	19202-04460	SEAL OIL	1				0.055	0.121
090	19013-07040	ASSY CASE MAIN BRG.	1	<=3Q0483			1.5	3.3
090	1A091-07042	ASSY BRG.CASE MAIN	1	>=3S0001	1		0	0
090	1A091-07043	ASSY BRG.CASE MAIN	1	>=3U0001	-		1.34	2.948
100	19013-04540	BOLT BEARING CASE	2	<=3Q0483			0.038	0.0836
100	1A091-04540	BOLT BEARING CASE	2	>=3S0001	1		0.035	0.077
105	1A091-23480	METAL CRANKSHAFT	1	>=3U0001		STD SET	0.05	0.11
110	19013-07050	ASSY CASE MAIN BRG.	1	<=3Q0483			1.495	3.289
110	1A091-07052	ASSY BRG.CASE MAIN	1	>=3S0001	1		0	0
110	1A091-07053	ASSY BRG.CASE MAIN	1	>=3U0001	-		1.34	2.948
120	19013-04540	BOLT BEARING CASE	2	<=3Q0483			0.038	0.0836
120	1A091-04540	BOLT BEARING CASE	2	>=3S0001	1		0.035	0.077
125	1A091-23480	METAL CRANKSHAFT	1	>=3U0001		STD SET	0.05	0.11
130	15601-04560	BOLT BEARING CASE	2				0.06	0.132

FLYWHEEL

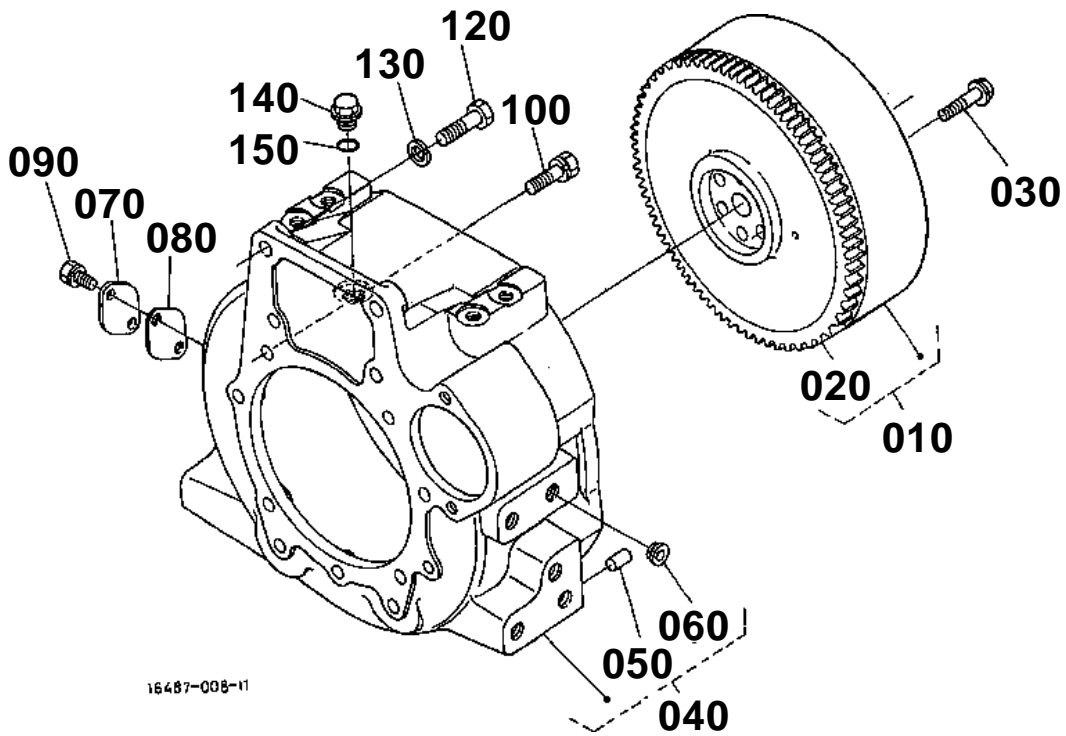

100 01073-51030

110 04512-50100

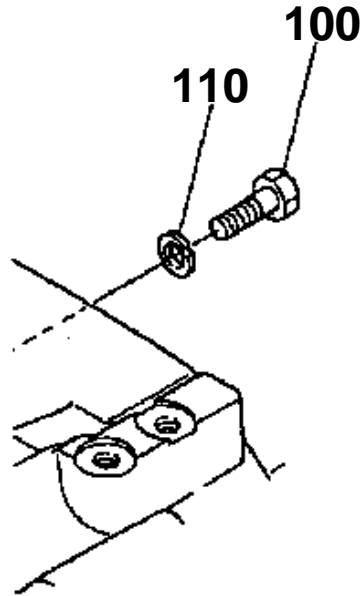

16467-811-10



FLYWHEEL

↔ Interchangeable; ≠ not interchangeable; ← new for old; → old for new

REF.No	Part No.	Description	Q'ty	S.No.	I/C	REMARKS	Weight (kgf)	Weight (lb)
010	16487-25010	COMP.FLYWHEEL	1				32	70.4
020	15221-63820	GEAR RING	1				1.2	2.64
030	15481-25160	BOLT FLYWHEEL	6				0.075	0.165
040	32751-20100	COMP.HOUSING F-W.	1				20	44
050	05012-01018	PIN STRAIGHT	2				0.012	0.0264
060	31220-14290	PLUG	9				0.002	0.0044
070	15521-04680	COVER	1				0.035	0.077
080	15521-04790	PACKING COVER	1				0.005	0.011
090	31351-23200	BOLT	2				0.005	0.011
100	01073-51030	BOLT	11	<=4964			0.028	0.0616
100	16427-91010	BOLT	11	>=4965	<<		0.004	0.0088
110	04512-50100	WASHER SPRING	11	<=4964			0	0
120	01073-51240	BOLT	2				0.049	0.1078
130	04512-60120	WASHER SPRING	2				0.005	0.011
140	T0070-32270	PLUG	1				0.03	0.066
150	04811-10140	O RING	1				0.001	0.0022

CYLINDER HEAD

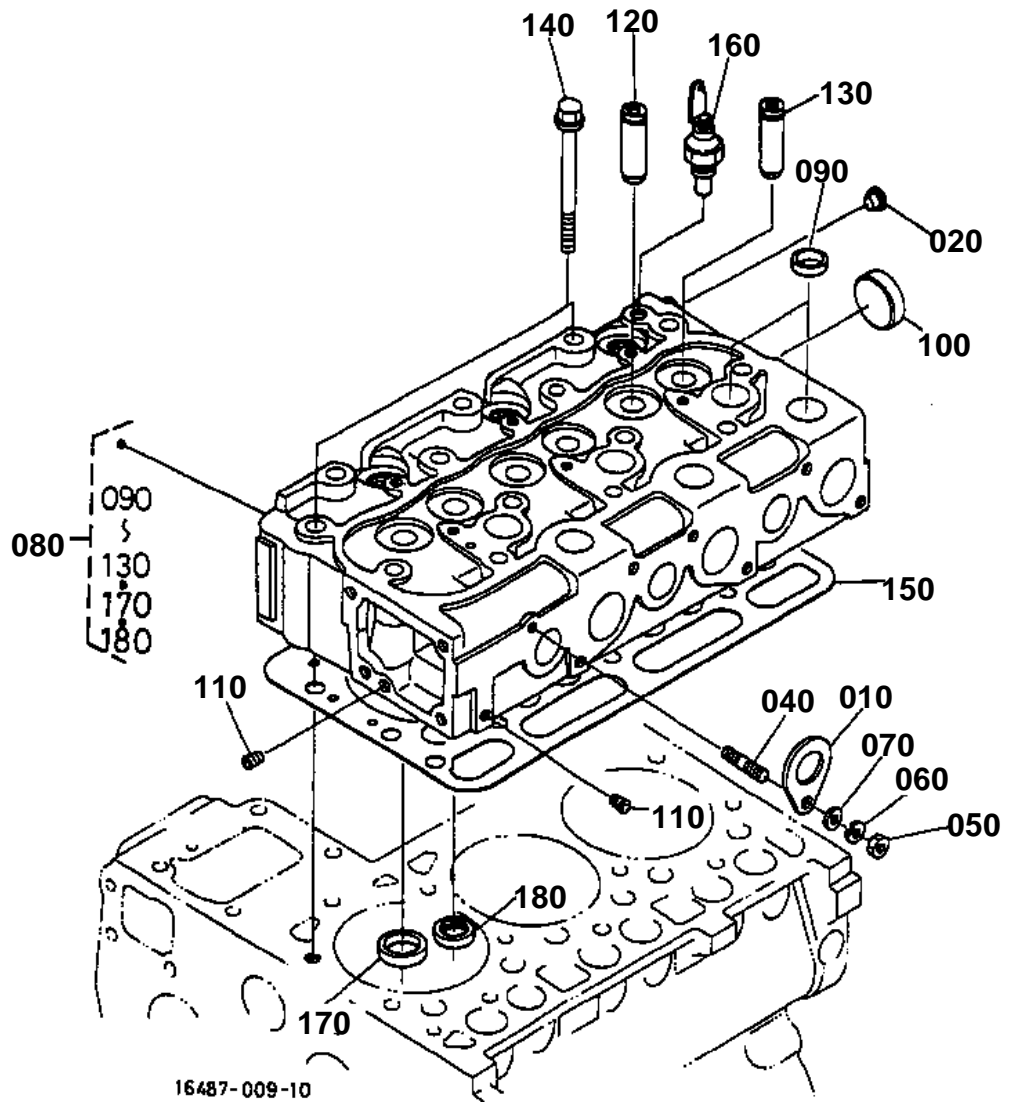

**CYLINDER HEAD**

↔ Interchangeable; ≠ not interchangeable; ← new for old; → old for new

REF.No	Part No.	Description	Q'ty	S.No.	I/C	REMARKS	Weight (kgf)	Weight (lb)
010	15221-01750	HOOK ENGINE	1				0.04	0.088
020	09980-10075	CAP PROTECTOR	1				0.001	0.0022
030	99999-99999	BLANK	0				0	0
040	15471-91530	STUD	1				0.01	0.022
050	02156-50080	NUT	1				0.004	0.0088
060	04512-60080	WASHER SPRING	1				0.002	0.0044
070	04012-50080	WASHER PLAIN	1				0.001	0.0022
080	16487-03040	COMP.CYLINDER HEAD	1	<=XU0506			0	0
080	16487-03045	COMP.CYLINDER HEAD	1	>=XU0507	-		15.02	33.044
080	1A033-03042	COMP.CYLINDER HEAD	1	>=3Y0001	1		0	0
090	15221-03370	CAP SEALING	9				0.01	0.022
100	15221-03490	CAP SEALING	1				0.02	0.044
110	15261-96010	PLUG	2				0.002	0.0044
120	17321-13580	GUIDE INLET VALVE	3				0.015	0.033
130	17321-13560	GUIDE EXHAUST VALVE	3				0.02	0.044
140	19013-03450	BOLT CYLINDER HEAD	14				0.077	0.1694
150	16487-03310	CASKET CYL.HEAD	1				0.105	0.231
160	31351-32830	SENSOR THERMO	1				0.02	0.044
170	16415-13620	SEAT INLET VALVE	3				0.01	0.022
180	16415-13612	SEAT EXHAUST VALVE	3				0.01	0.022

VALVE AND ROCKER ARM [OLD TYPE]

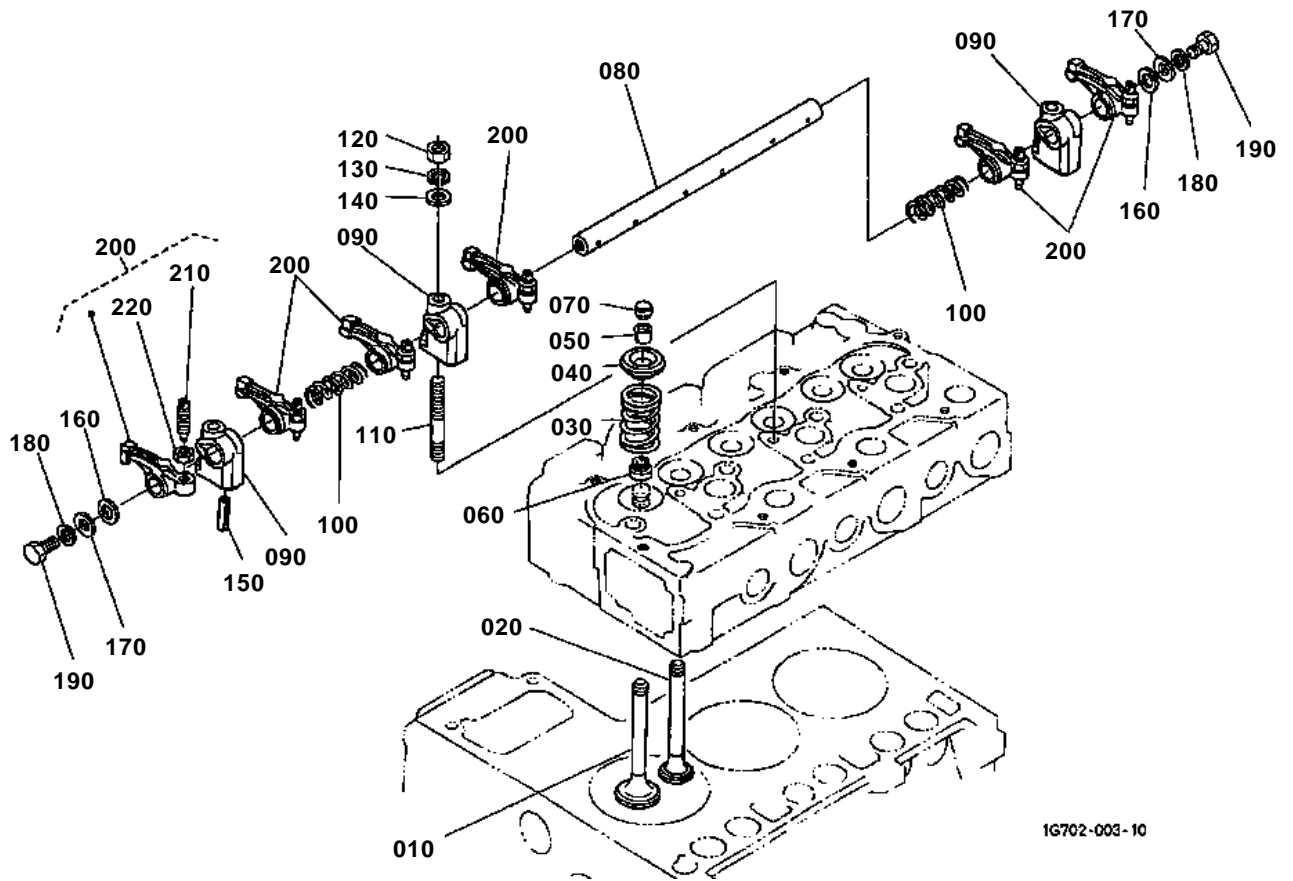

1G702-003-10

150 15221-1442-0

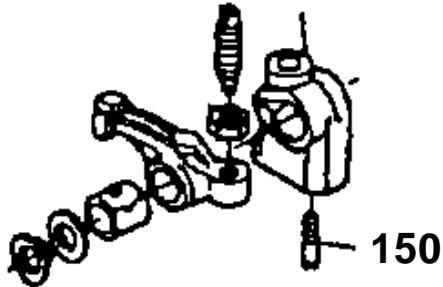

080 15321-1405-0

080 15321-1405-2

230 03410-00808

240 04612-00140

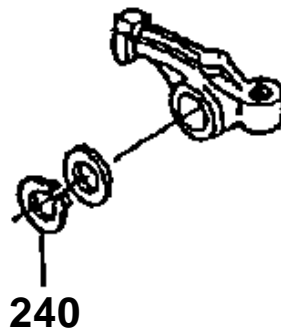
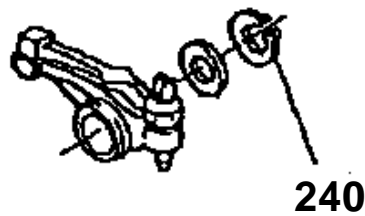
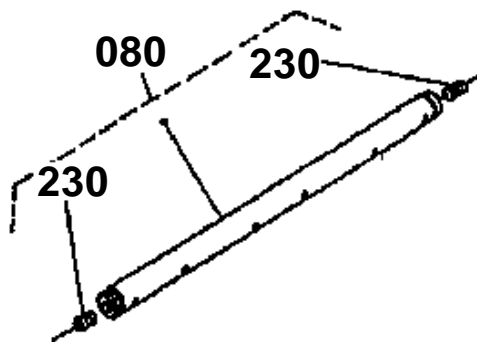

16467-812-20

**VALVE AND ROCKER ARM [OLD TYPE]**

S.No.;<=3W0593

↔ Interchangeable; ≠ not interchangeable; ← new for old; → old for new

REF.No	Part No.	Description	Q'ty	S.No.	I/C	REMARKS	Weight (kgf)	Weight (lb)
010	16484-13110	VALVE INLET	3				0.06	0.132
020	16484-13120	VALVE EXHAUST	3				0.13	0.286
030	15221-13240	SPRING VALVE	6				0.036	0.0792
040	15221-13330	RETAINER VALVE SP.	6				0.03	0.066
050	15221-13360	COLLET VALVE SPRING	6				0	0
050	15221-13980	COLLET VALVE SPRING	6		«		0.002	0.0044
060	15221-13150	SEAL VALVE STEM	6	<=3S0588			0.001	0.0022
060	15221-13153	SEAL VALVE STEM	6	>=3U0001	—		0.001	0.0022
070	15221-13280	CAP VALVE	6				0.006	0.0132
080	15321-14050	ASSY SHAFT R-ARM	1	<=3108		NOT SALE	0.25	0.55
080	15321-14052	ASSY SHAFT R-ARM	1	>=3109	1	NOT SALE	0.235	0.517
080	1A021-14260	SHAFT ROCKER ARM	1	>=2A0001	1		0.225	0.495
090	15221-14350	BRACKET ROCKER ARM	3				0.044	0.0968
100	15221-14310	SPRING ROCKER ARM	2				0.005	0.011
110	15521-91500	STUD	3				0.035	0.077
120	02156-50080	NUT	3				0.004	0.0088
130	04512-60080	WASHER SPRING	3				0.002	0.0044
140	04012-50080	WASHER PLAIN	3				0.001	0.0022
150	15221-14420	SCREW SET.ROCKER ARM	1	<=3108			0.003	0.0066
150	05411-00528	PIN SPRING	1	>=3109	1		0.003	0.0066
160	15221-14430	WASHER R-ARM.SHAFT	2				0.002	0.0044
170	04013-60080	WASHER PLAIN	2	>=2A0001			0.002	0.0044
180	04512-60080	WASHER SPRING	2	>=2A0001			0.002	0.0044
190	01153-50812	BOLT	2	>=2A0001			0.008	0.0176
200	15621-14030	ASSY ROCKER ARM	6				0.1	0.22
210	15521-14230	SCREW ADJUSTING	6				0.009	0.0198
220	15021-14240	NUT	6				0.003	0.0066
230	03410-00808	SCREW SET	2	<=1Y0497			0	0
240	04612-00140	CIRCLIP EXTERNAL	2	<=1Y0497			0.001	0.0022

VALVE AND ROCKER ARM [NEW TYPE]

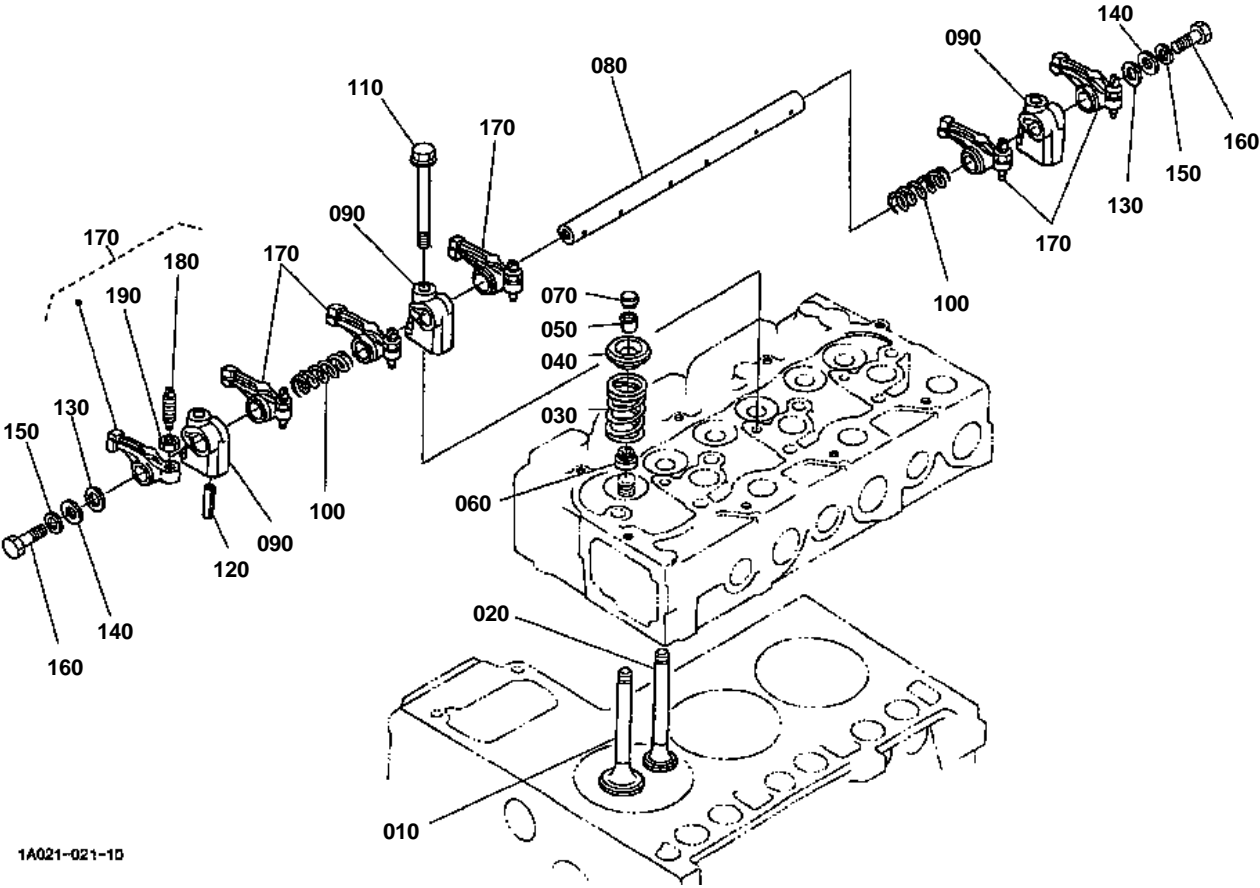

1A021-021-10

**VALVE AND ROCKER ARM [NEW TYPE]**

S.No.;>=3Y0001

↔ Interchangeable; ≠ not interchangeable; ← new for old; → old for new

REF.No	Part No.	Description	Q'ty	S.No.	I/C	REMARKS	Weight (kgf)	Weight (lb)
010	16484-13110	VALVE INLET	3				0.06	0.132
020	16484-13120	VALVE EXHAUST	3				0.13	0.286
030	15221-13240	SPRING VALVE	6				0.036	0.0792
040	15221-13330	RETAINER VALVE SP.	6				0.03	0.066
050	15221-13980	COLLET VALVE SPRING	6			SET	0.002	0.0044
060	15221-13153	SEAL VALVE STEM	6				0.001	0.0022
070	15221-13280	CAP VALVE	6				0.006	0.0132
080	1A021-14260	SHAFT ROCKER ARM	1				0.225	0.495
090	15221-14350	BRACKET.ROCKER ARM	3				0.044	0.0968
100	15221-14310	SPRING ROCKER ARM	2				0.005	0.011
110	01754-50855	BOLT FLANGE	3				0.02	0.044
120	05411-00528	PIN SPRING	1				0.003	0.0066
130	15221-14430	WASHER R-ARM.SHAFT	2				0.002	0.0044
140	04013-60080	WASHER PLAIN	2				0.002	0.0044
150	04512-60080	WASHER SPRING	2				0.002	0.0044
160	01153-50812	BOLT	2				0.008	0.0176
170	15621-14030	ASSY ROCKER ARM	6				0.1	0.22
180	15521-14230	SCREW ADJUSTING	6				0.009	0.0198
190	15021-14240	NUT	6				0.003	0.0066

NOZZLE HOLDER AND GLOW PLUG

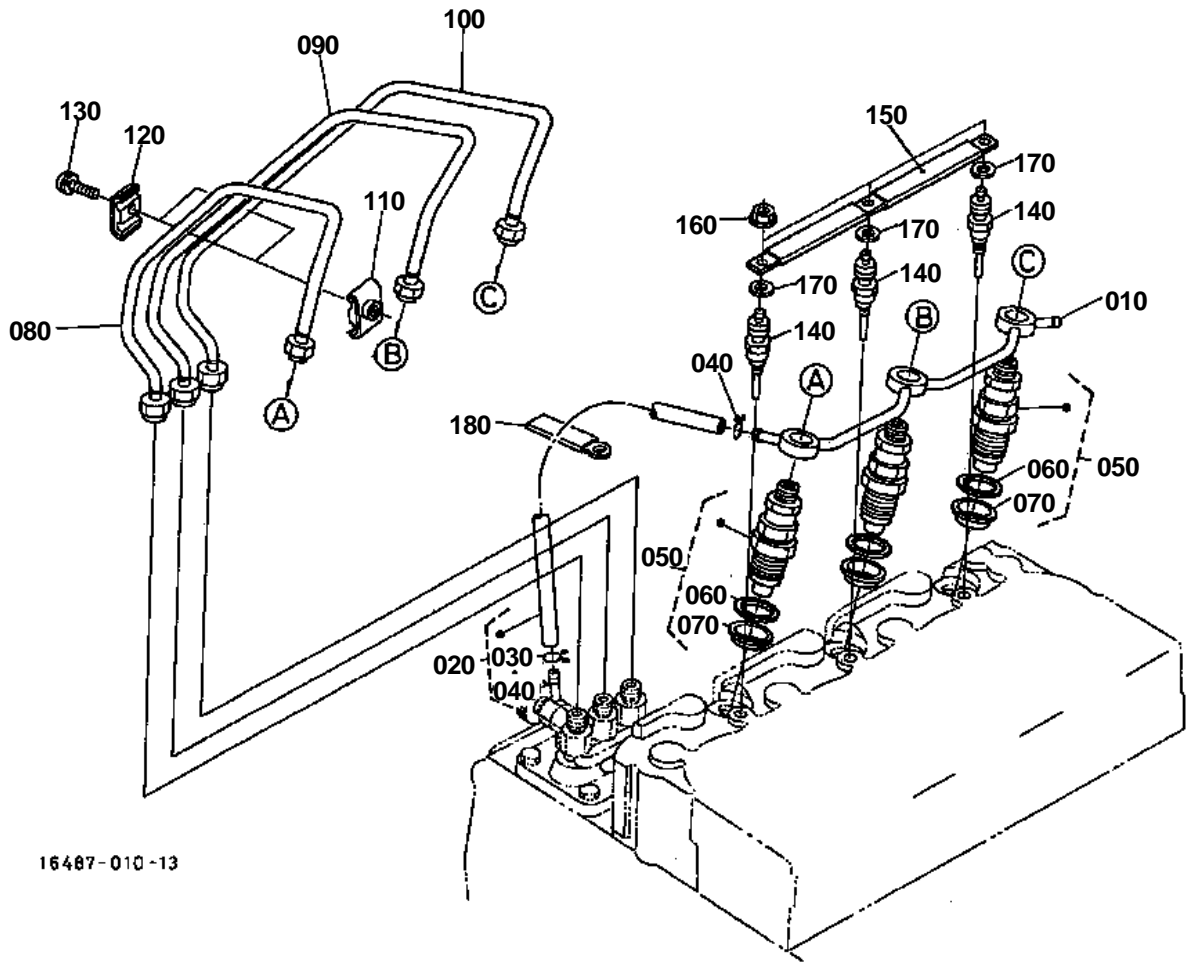

170 04013-60040

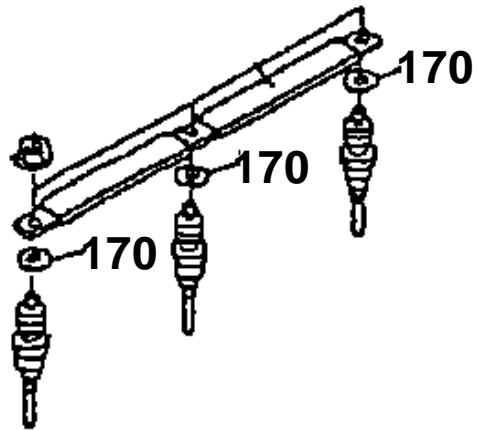

16487-821- 20



NOZZLE HOLDER AND GLOW PLUG

↔ Interchangeable; ≠ not interchangeable; ← new for old; → old for new

REF.No	Part No.	Description	Q'ty	S.No.	I/C	REMARKS	Weight (kgf)	Weight (lb)
010	16467-42502	ASSY PIPE OVER FLOW	1				0.045	0.099
020	17331-42500	ASSY PIPE OVER FLOW	1				0.02	0.044
030	14971-42750	CLIP PIPE	1				0.001	0.0022
040	10244-42320	CLIP PIPE	1				0.001	0.0022
050	16082-53000	ASSY HOLDER NOZZLE	3			NOT SALE	0.13	0.286
050	16082-53900	KIT HOLDER NOZZLE	3				0.145	0.319
060	15841-53620	GASKET	3				0	0
060	15841-53622	GASKET	3		«		0.002	0.0044
070	19077-53650	SEAL HEAT	3				0.005	0.011
080	19077-53710	PIPE INJECTION	1	<=7749		NOT SALE	0	0
080	19077-53714	PIPE INJECTION	1	>=7750	1		0.14	0.308
090	19077-53720	PIPE INJECTION	1	<=7749		NOT SALE	0	0
090	19077-53723	PIPE INJECTION	1	>=7750	1		0.14	0.308
100	19077-53730	PIPE INJECTION	1	<=7749		NOT SALE	0	0
100	19077-53733	PIPE INJECTION	1	>=7750	1		0.12	0.264
110	15841-53850	CLAMP PIPE	2				0.01	0.022
120	15841-53860	CLAMP PIPE	2				0.009	0.0198
130	03024-50520	SCREW WITH WASHER	2				0.004	0.0088
140	19077-65510	PLUG GLOW	3				0.03	0.066
150	16415-65560	CORD GLOW PLUG	1	<=4E1597			0.015	0.033
150	1G742-65560	CORD GLOW PLUG	1	>=4G0001	—		0	0
160	02761-50040	NUT FLANGE	3				0.002	0.0044
170	04013-50040	WASHER PLAIN	3	<=XU0506			0	0
180	15272-67590	CLAMP CORD	1				0.004	0.0088

NOZZLE HOLDER [COMPONENT PARTS]

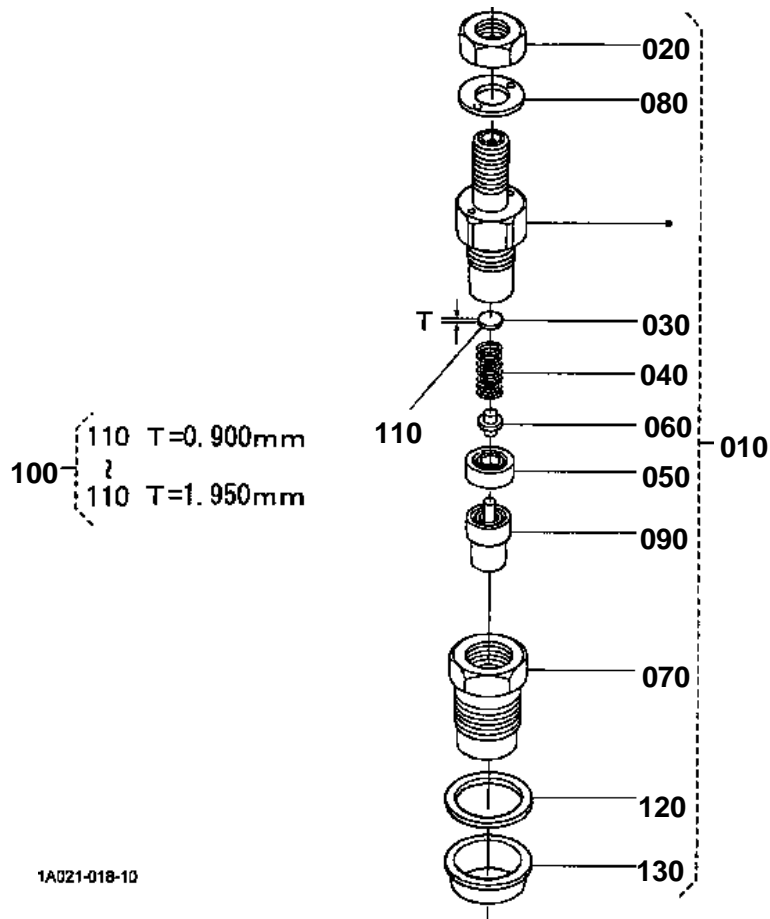

1A021-018-10



NOZZLE HOLDER [COMPONENT PARTS]

↔ Interchangeable; ≠ not interchangeable; ← new for old; → old for new

REF.No	Part No.	Description	Q'ty	S.No.	I/C	REMARKS	Weight (kgf)	Weight (lb)
010	16082-53000	ASSY HOLDER NOZZLE	3			NOT SALE	0.13	0.286
010	16082-53900	KIT HOLDER NOZZLE	3				0.145	0.319
020	15841-92030	NUT	3				0.005	0.011
030	15841-53230	WASHER ADJUSTING	3			0.900mm	0.001	0.0022
040	15841-53170	SPRING NOZZLE	3				0.004	0.0088
050	15841-53350	PIECE DISTANCE	3				0.004	0.0088
060	15841-53160	PUSH ROD	3				0.001	0.0022
070	15841-53280	NUT NOZZLE	3				0	0
080	15841-94040	WASHER	3				0.001	0.0022
090	16082-53610	PIECE NOZZLE	3				0.023	0.0506
100	15841-98100	ASSY WASHER ADJUST	3			OPTION	0.043	0.0946
110	15841-53230	WASHER ADJUSTING	3			0.900mm	0.001	0.0022
110	15841-98510	WASHER ADJUSTING	3			0.925mm	0.001	0.0022
110	15841-98520	WASHER ADJUSTING	3			0.950mm	0.001	0.0022
110	15841-98530	WASHER ADJUSTING	3			0.975mm	0.001	0.0022
110	15841-98540	WASHER ADJUSTING	3			1.000mm	0.001	0.0022
110	15841-98550	WASHER ADJUSTING	3			1.025mm	0.001	0.0022
110	15841-98560	WASHER ADJUSTING	3			1.050mm	0.001	0.0022
110	15841-98570	WASHER ADJUSTING	3			1.075mm	0.001	0.0022
110	15841-98580	WASHER ADJUSTING	3			1.100mm	0.001	0.0022
110	15841-98590	WASHER ADJUSTING	3			1.125mm	0.001	0.0022
110	15841-98600	WASHER ADJUSTING	3			1.150mm	0.001	0.0022
110	15841-98610	WASHER ADJUSTING	3			1.175mm	0.001	0.0022
110	15841-98620	WASHER ADJUSTING	3			1.200mm	0.001	0.0022
110	15841-98630	WASHER ADJUSTING	3			1.225mm	0.001	0.0022
110	15841-98640	WASHER ADJUSTING	3			1.250mm	0.001	0.0022
110	15841-98650	WASHER ADJUSTING	3			1.275mm	0.001	0.0022
110	15841-98660	WASHER ADJUSTING	3			1.300mm	0.001	0.0022
110	15841-98670	WASHER ADJUSTING	3			1.325mm	0.001	0.0022
110	15841-98680	WASHER ADJUSTING	3			1.350mm	0.001	0.0022
110	15841-98690	WASHER ADJUSTING	3			1.375mm	0.001	0.0022
110	15841-98700	WASHER ADJUSTING	3			1.400mm	0.001	0.0022
110	15841-98710	WASHER ADJUSTING	3			1.425mm	0.001	0.0022
110	15841-98720	WASHER ADJUSTING	3			1.450mm	0.001	0.0022
110	15841-98730	WASHER ADJUSTING	3			1.475mm	0.001	0.0022
110	15841-98740	WASHER ADJUSTING	3			1.500mm	0.001	0.0022
110	15841-98750	WASHER ADJUSTING	3			1.525mm	0.001	0.0022
110	15841-98760	WASHER ADJUSTING	3			1.550mm	0.001	0.0022
110	15841-98770	WASHER ADJUSTING	3			1.575mm	0.001	0.0022
110	15841-98780	WASHER ADJUSTING	3			1.600mm	0.002	0.0044
110	15841-98790	WASHER ADJUSTING	3			1.625mm	0.001	0.0022
110	15841-98800	WASHER ADJUSTING	3			1.650mm	0.001	0.0022
110	15841-98810	WASHER ADJUSTING	3			1.675mm	0.004	0.0088
110	15841-98820	WASHER ADJUSTING	3			1.700mm	0.001	0.0022
110	15841-98830	WASHER ADJUSTING	3			1.725mm	0.001	0.0022
110	15841-98840	WASHER ADJUSTING	3			1.750mm	0.001	0.0022
110	15841-98850	WASHER ADJUSTING	3			1.775mm	0.001	0.0022
110	15841-98860	WASHER ADJUSTING	3			1.800mm	0.001	0.0022
110	15841-98870	WASHER ADJUSTING	3			1.825mm	0.001	0.0022
110	15841-98880	WASHER ADJUSTING	3			1.850mm	0.001	0.0022
110	15841-98890	WASHER ADJUSTING	3			1.875mm	0.001	0.0022

**NOZZLE HOLDER [COMPONENT PARTS]**

↔ Interchangeable; ≠ not interchangeable; ← new for old; → old for new

REF.No	Part No.	Description	Q'ty	S.No.	I/C	REMARKS	Weight (kgf)	Weight (lb)
110	15841-98900	WASHER ADJUSTING	3			1.900mm	0.001	0.0022
110	15841-98910	WASHER ADJUSTING	3			1.925mm	0.001	0.0022
110	15841-98920	WASHER ADJUSTING	3			1.950mm	0.001	0.0022
120	15841-53620	GASKET	3				0	0
120	15841-53622	GASKET	3		«		0.002	0.0044
130	19077-53650	SEAL HEAT	3				0.005	0.011

CYLINDER HEAD COVER [OLD TYPE]

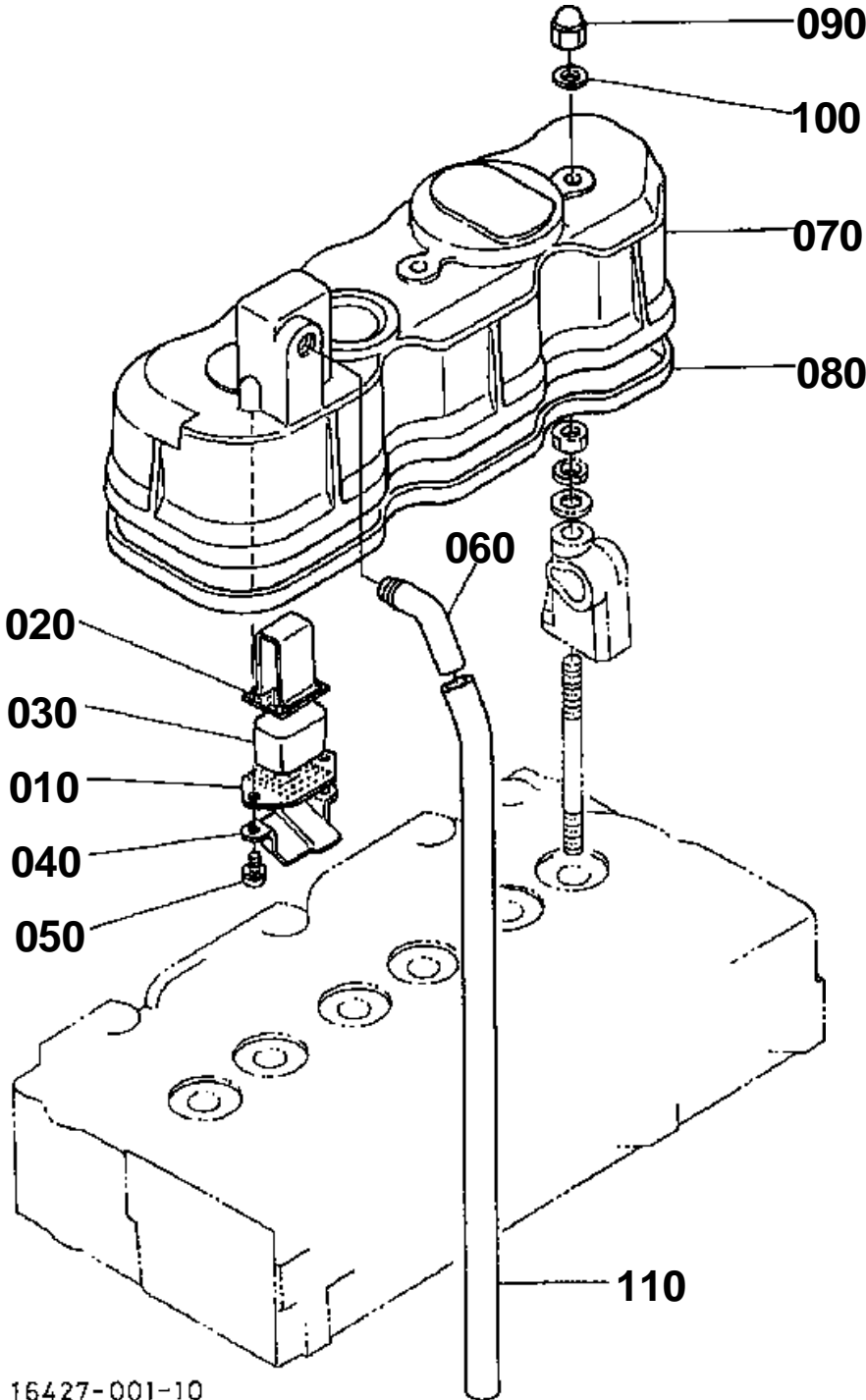

16427-001-10

**CYLINDER HEAD COVER [OLD TYPE]**

S.No.;<=3W0593

↔ Interchangeable; ≠ not interchangeable; ← new for old; → old for new

REF.No	Part No.	Description	Q'ty	S.No.	I/C	REMARKS	Weight (kgf)	Weight (lb)
010	15521-05140	PLATE B/THER ELEMENT	1				0.005	0.011
020	15521-05150	PLATE B/THER ELEMENT	1				0.01	0.022
030	15521-05670	ELEMENT BREATHER	1				0.01	0.022
040	15521-05370	OIL SHIELD BREATHER	1				0.005	0.011
050	03034-50510	SCREW WITH WASHER	2				0.003	0.0066
060	17365-05550	JOINT BREATHER	1				0.065	0.143
070	16427-14510	COVER CYL.HEAD	1				1.13	2.486
080	15521-14520	GASKET HEAD COVER	1				0.035	0.077
090	15451-92330	NUT CAP	3				0.008	0.0176
100	15021-33660	GASKET	3				0.001	0.0022
110	15837-05510	PIPE BREATHER	1				0.06	0.132

CYLINDER HEAD COVER [NEW TYPE]

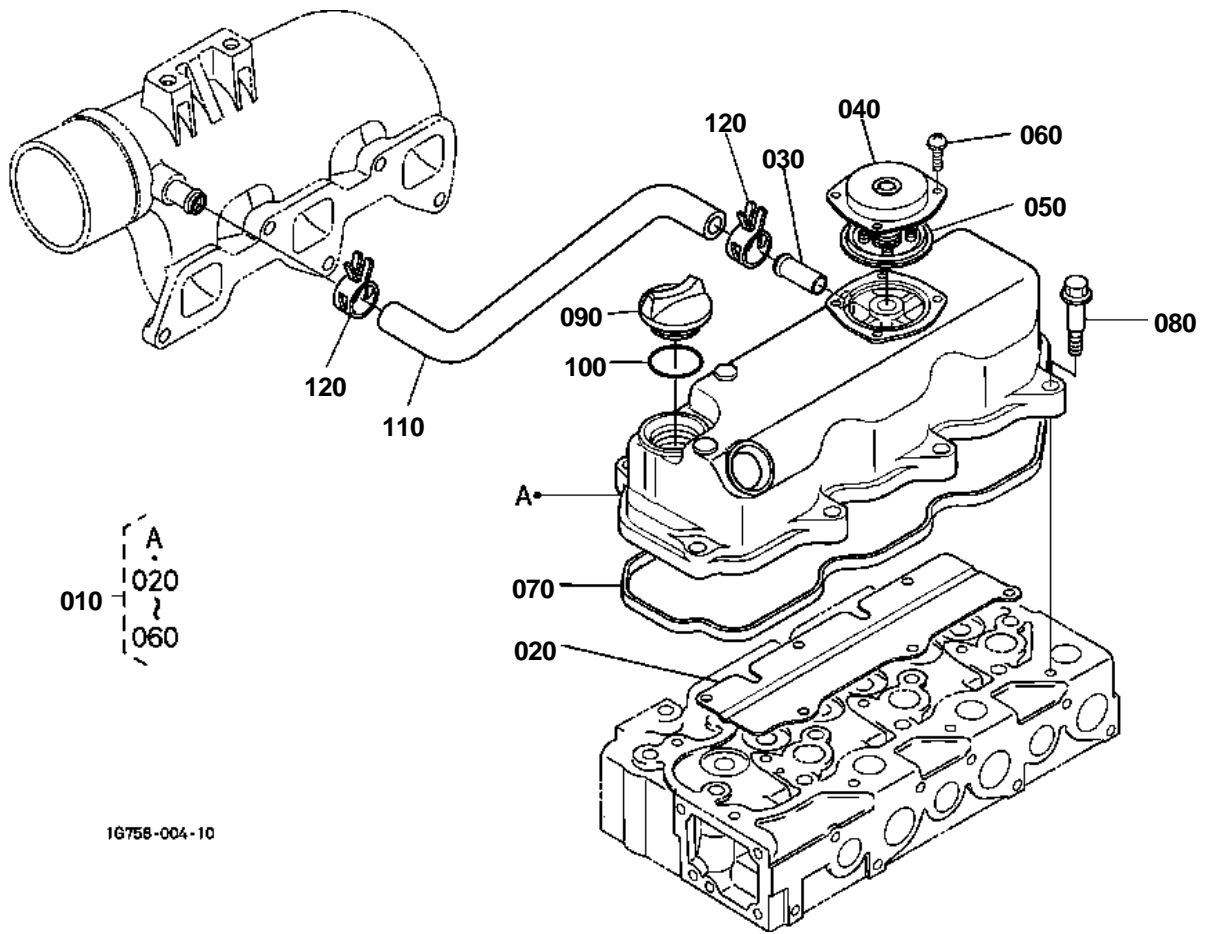

1G756-004-10

**CYLINDER HEAD COVER [NEW TYPE]**

S.No.;>=3Y0001

↔ Interchangeable; ≠ not interchangeable; ← new for old; → old for new

REF.No	Part No.	Description	Q'ty	S.No.	I/C	REMARKS	Weight (kgf)	Weight (lb)
010	1G750-14503	ASSY COVER CYL.HEAD	1				0	0
020	1A021-05370	SHIELD BREATHER	1				0.1	0.22
030	17331-73342	PIPE WATER RETURN	1				0.01	0.022
040	1G911-05120	COVER BREATHER	1				0	0
050	1G911-05200	COMP.VALVE BREATHER	1				0	0
060	03024-50510	SCREW WITH WASHER	4				0.002	0.0044
070	1A021-14520	GASKET HEAD COVER	1				0	0
080	1G911-91022	BOLT	8				0.015	0.033
090	15852-33140	PLUG OIL FILLER	1				0.038	0.0836
100	04817-50300	O RING	1				0.001	0.0022
110	1G780-05510	TUBE BREATHER	1				0.06	0.132
120	09318-88180	BAND HOSE	2				0.01	0.022

INLET MANIFOLD

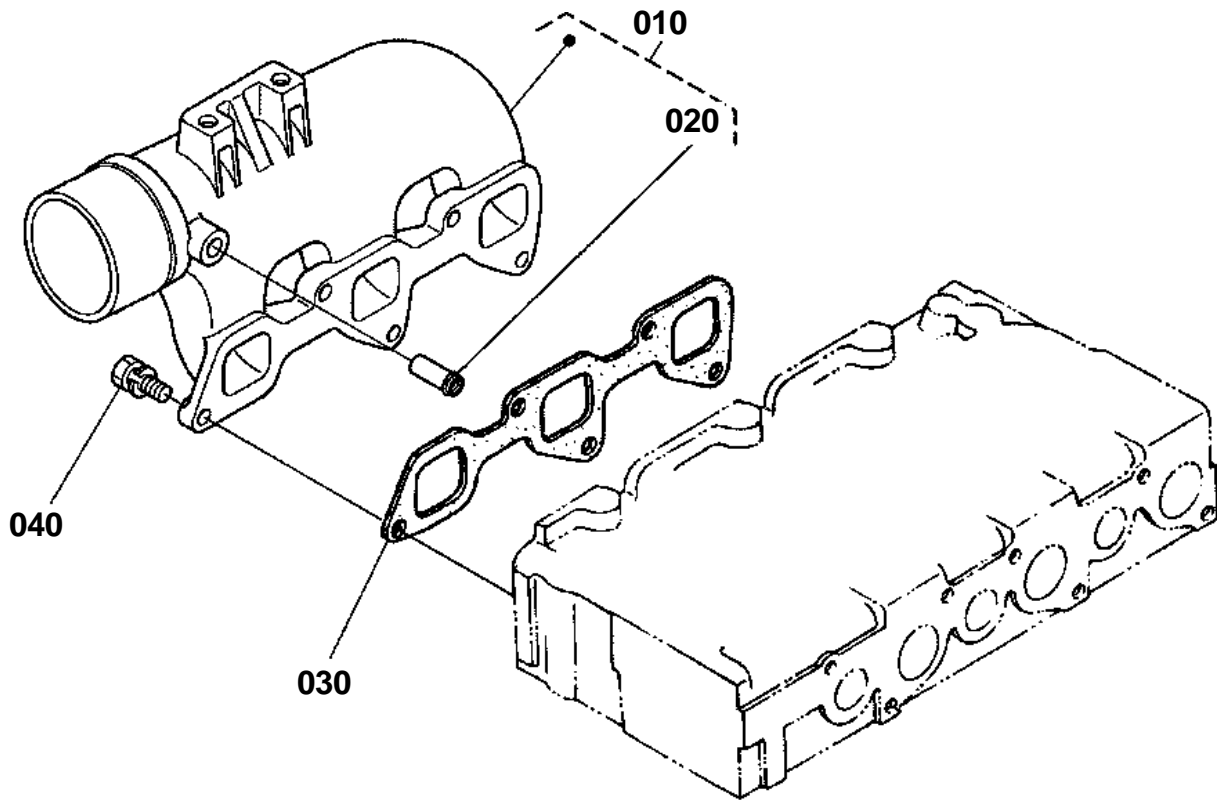

1G758-008-10

INLET MANIFOLD

010 16415-1176-0

010 16427-1176-0

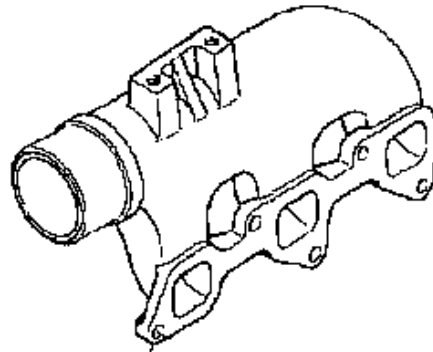

010

1G758-800-10



INLET MANIFOLD

↔ Interchangeable; ≠ not interchangeable; ← new for old; → old for new

REF.No	Part No.	Description	Q'ty	S.No.	I/C	REMARKS	Weight (kgf)	Weight (lb)
010	16415-11760	MANIFOLD INLET	1				0	0
010	16427-11760	MANIFOLD INLET	1	<=3W0593	<<		0.9	1.98
010	1G751-11772	ASSY MANIFOLD INLET	1	>=3Y0001	1		0.9	1.98
020	17331-73342	PIPE WATER RETURN	1	>=3Y0001			0.01	0.022
030	17326-11820	GASKET IN-MANIFOLD	1	<=2S0315			0	0
030	1A021-11822	GASKET IN-MANIFOLD	1	>=2U0001	-		0.006	0.0132
040	01123-50822	BOLT	5				0.012	0.0264

AIR CLEANER

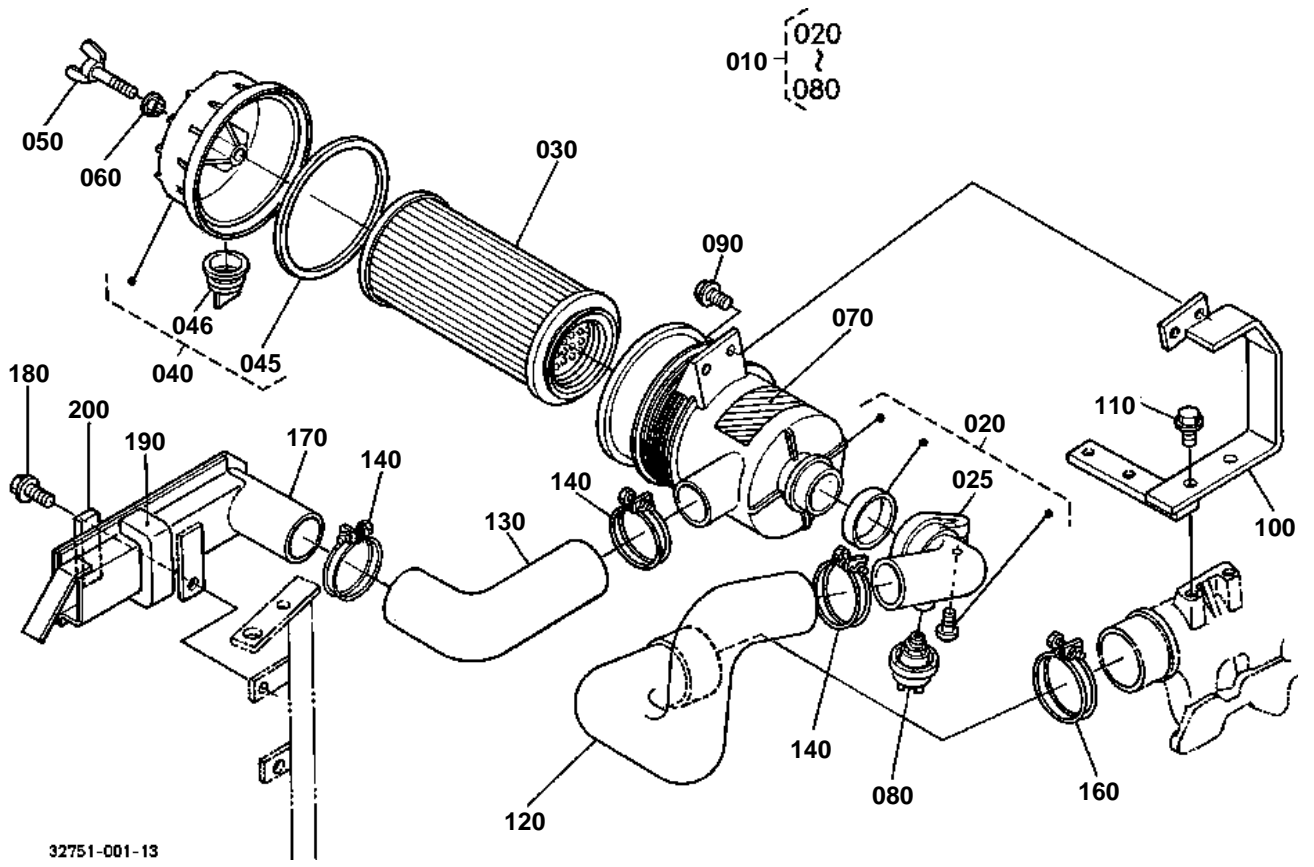

32751-001-13

150 T0270-3556-0

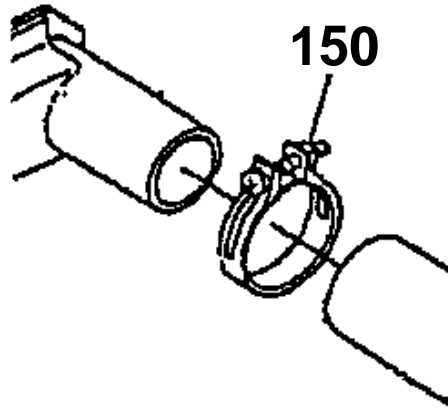

150 09318-89063

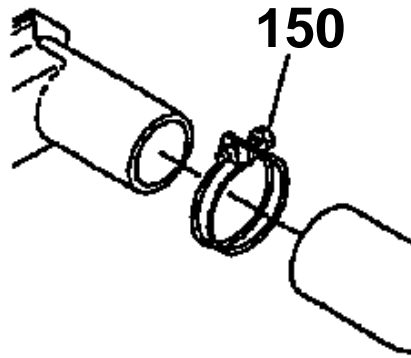

32751-813-11

**AIR CLEANER**

↔ Interchangeable; ≠ not interchangeable; ← new for old; → old for new

REF.No	Part No.	Description	Q'ty	S.No.	I/C	REMARKS	Weight (kgf)	Weight (lb)
010	TA040-16300	ASSY CLEANER AIR	1				1.05	2.31
020	TA040-16310	COMP.BODY A/C	1				0.42	0.924
025	TA040-93120	PIPE AIR CLEANER	1				0.07	0.154
030	T0070-16323	COMP.FILTER A/C	1				0.38	0.836
040	T0070-93173	ASSY CUP AIR CLEANER	1				0.2	0.44
045	T0070-93150	SEAL AIR CLEANER	1				0.004	0.0088
046	T0070-93160	VALVE	1				0.01	0.022
050	T0070-16342	BOLT WING	1				0.021	0.0462
060	T0070-16350	SEAL WASHER	1				0.001	0.0022
070	TA040-93180	LABEL AIR CLEANER	1				0.002	0.0044
080	TA040-16380	SENSOR AIR CLEANER	1				0.057	0.1254
090	01754-50816	BOLT FLANGE	2				0.011	0.0242
100	32751-13910	SUPPORT AIR CLEANER	1				0.58	1.276
110	01754-50820	BOLT FLANGE	2				0.015	0.033
120	32751-16330	HOSE	1				0.505	1.111
130	32751-16350	HOSE	1				0.25	0.55
140	09318-89063	CLAMP HOSE	2	<=72272			0.04	0.088
140	09318-89066	CLAMP HOSE	3	>=72273	1		0.036	0.0792
140	T0270-35560	CLAMP HOSE	1	>=73399	1		0.035	0.077
150	15401-11720	BAND PIPE	1				0.03	0.066
150	T0270-35560	CLAMP HOSE	1		«		0.035	0.077
150	09318-89063	CLAMP HOSE	1		«		0.04	0.088
150	09318-89063	CLAMP HOSE	1	<=72272			0.04	0.088
160	09318-89069	CLAMP HOSE	1	<=73398			0.04	0.088
160	31351-18110	BAND PIPE	1	>=73399	1		0.04	0.088
170	32751-16340	PIPE INLET	1				0.83	1.826
180	01754-50812	BOLT FLANGE	1				0.01	0.022
190	32751-16360	SPONGE	1				0.008	0.0176
200	32751-16370	SPONGE	1				0.003	0.0066

EXHAUST MANIFOLD AND MUFFLER

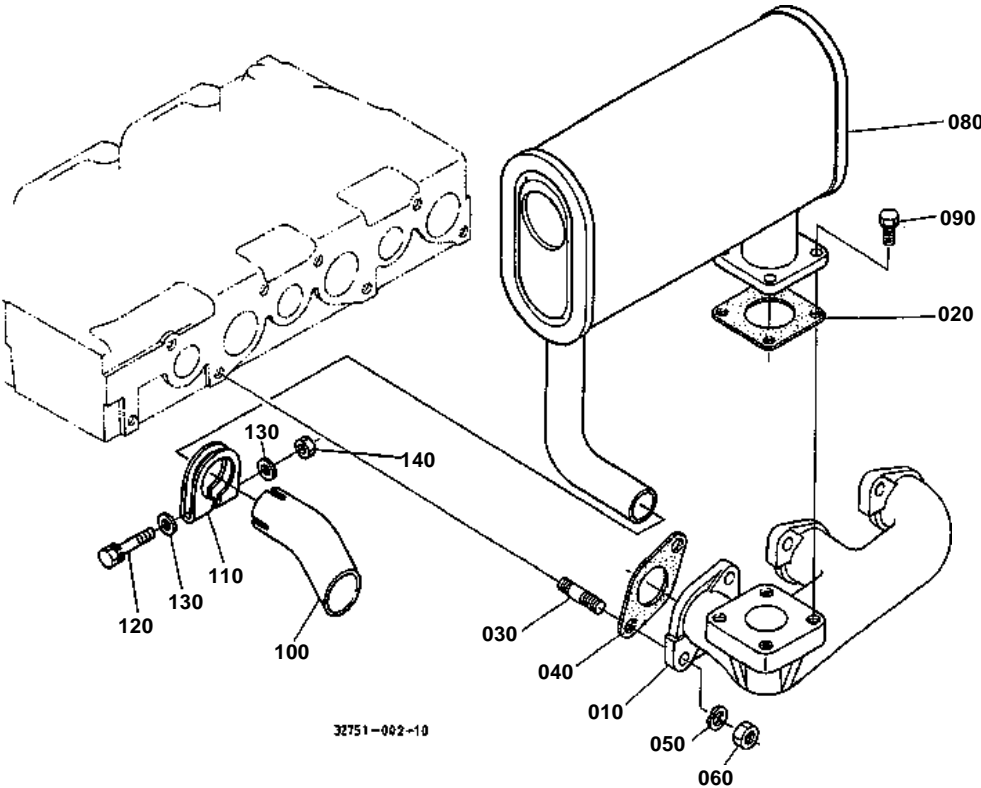



EXHAUST MANIFOLD AND MUFFLER

↔ Interchangeable; ≠ not interchangeable; ← new for old; → old for new

REF.No	Part No.	Description	Q'ty	S.No.	I/C	REMARKS	Weight (kgf)	Weight (lb)
010	17367-12312	MANIFOLD EXHAUST	1	<=60658			0	0
010	17367-12313	MANIFOLD EXHAUST	1	>=60659	<<		2	4.4
020	T0070-16420	GASKET MUFFLER	1				0.016	0.0352
030	15221-91530	STUD	6				0.011	0.0242
040	15313-12350	GASKET EX-MANIFOLD	1				0.04	0.088
040	1A021-12350	GASKET EX-MANIFOLD	1		<<		0.028	0.0616
050	04512-60080	WASHER SPRING	6				0.002	0.0044
060	02156-50080	NUT	6				0.004	0.0088
070	99999-99999	BLANK	0				0	0
080	32751-16410	MUFFLER	1				6.8	14.96
090	01123-50822	BOLT	4	<=72318			0.012	0.0264
090	01128-50825	BOLT	4	>=72319	1		0.015	0.033
100	32751-16420	PIPE MUFFLER	1				0.11	0.242
110	67800-53420	BAND PIPE	1				0.04	0.088
120	01123-50865	BOLT	1				0.028	0.0616
130	04013-50080	WASHER PLAIN	2				0	0
140	02114-50080	NUT	1				0.005	0.011

CAMSHAFT

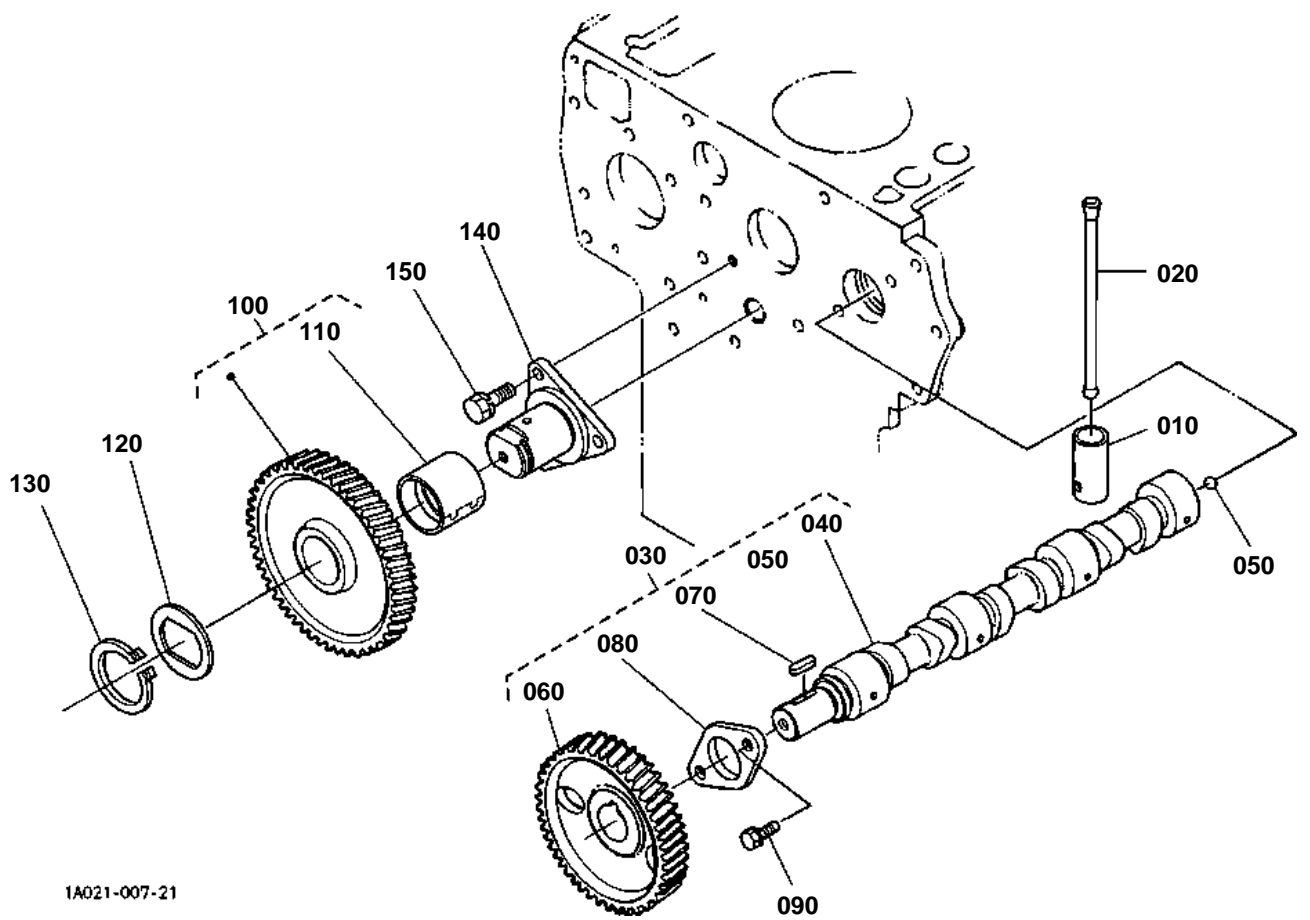

1A021-007-21

050 15521-9361-0

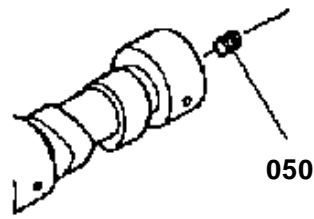

100 16427-2401-0

100 1A053-2401-0

110 16427-2498-0

120 16427-2436-0

140 16427-2425-0

160 16427-2437-0

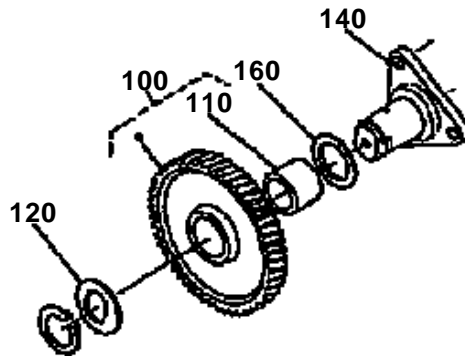

16467-815-12

**CAMSHAFT**

↔ Interchangeable; ≠ not interchangeable; ← new for old; → old for new

REF.No	Part No.	Description	Q'ty	S.No.	I/C	REMARKS	Weight (kgf)	Weight (lb)
010	15601-15550	TAPPET	6				0.08	0.176
020	19013-15110	PUSH ROD	6				0.05	0.11
030	17333-16010	ASSY CAMSHAFT	1				2.7	5.94
040	17333-16150	CAMSHAFT	1				1.7	3.74
050	15521-93610	SCREW SET	1	<=3W0593			0.002	0.0044
050	07715-00401	BALL	1	>=3Y0001	1		0.001	0.0022
060	15521-16510	GEAR CAMSHAFT	1	<=1W0387			0	0
060	15521-16514	GEAR CAMSHAFT	1	>=1Y0001	→		0	0
060	15521-16515	GEAR CAM	1	>=4A0001	→		0.85	1.87
070	05712-00720	KEY FEATHER	1				0.008	0.0176
080	15221-16270	STOPPER CAMSHAFT	1				0.073	0.1606
090	01123-50818	BOLT	2				0.012	0.0264
100	16427-24010	COMP.GEAR IDLE	1	<=1W0387			1.2	2.64
100	1A053-24010	COMP.GEAR IDLE	1	>=1Y0001	→		0	0
100	1G791-24010	COMP GEAR IDLE	1	>=2A0001	1		1.195	2.629
110	16427-24980	BUSH IDLE GEAR	1	<=1W0387			0.07	0.154
110	1A021-24980	BUSH IDLE GEAR	1	>=1Y0001	→		0.072	0.1584
120	16427-24360	COLLAR	1	<=1W0387			0.02	0.044
120	1A021-24370	COLLAR	1	>=1Y0001	1		0.022	0.0484
130	15451-95400	CIRCLIP EXTERNAL	1				0.01	0.022
140	16427-24250	SHAFT IDLE GEAR	1	<=1W0387			0.65	1.43
140	1A021-24250	SHAFT IDLE GEAR	1	>=1Y0001	1		0.685	1.507
150	01123-50818	BOLT	3				0.012	0.0264
160	16427-24370	COLLAR	1	<=1W0387			0.02	0.044

GEAR CASE

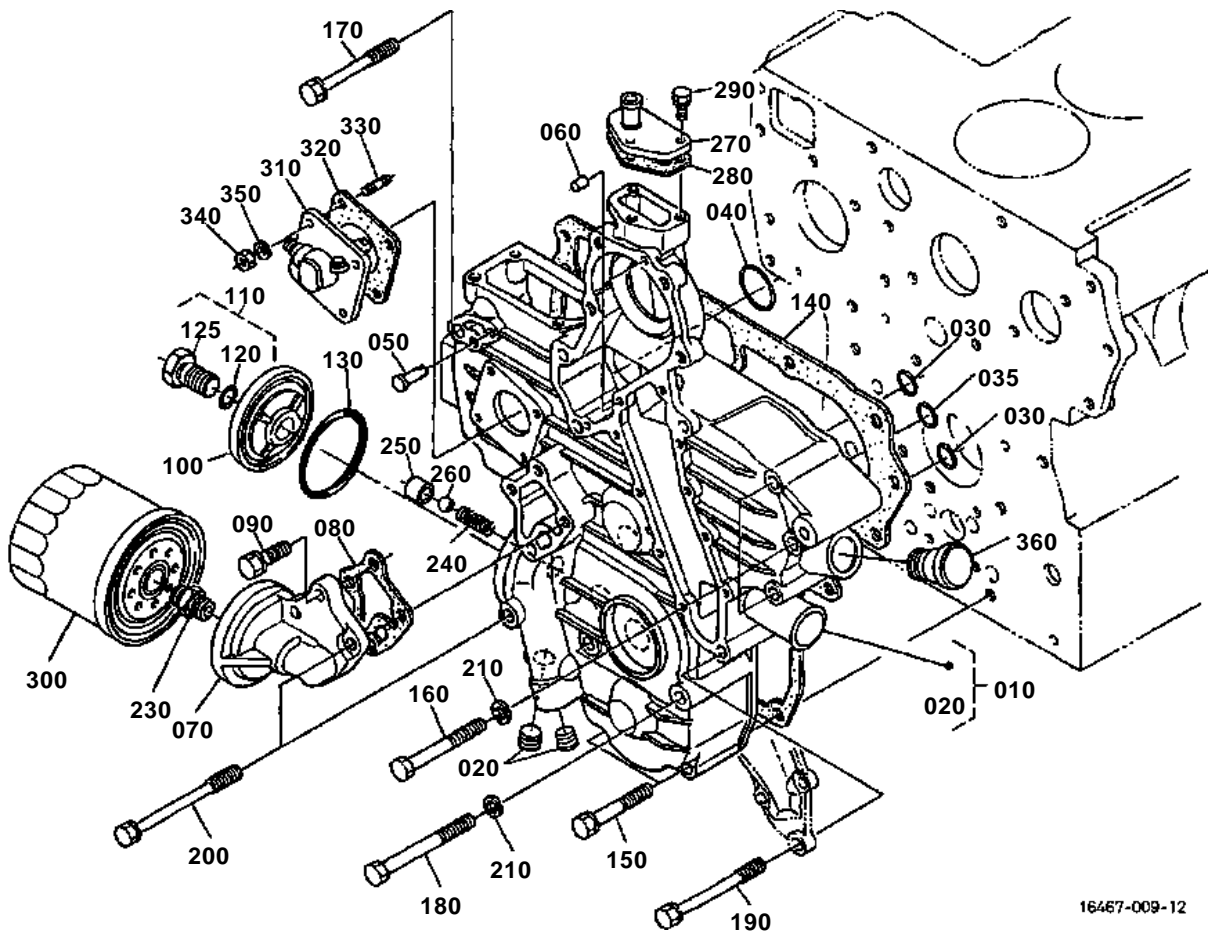

16467-009-12



GEAR CASE

↔ Interchangeable; ≠ not interchangeable; ← new for old; → old for new

REF.No	Part No.	Description	Q'ty	S.No.	I/C	REMARKS	Weight (kgf)	Weight (lb)
010	16705-04023	COMP.CASE GEAR	1				2.5	5.5
020	16241-96020	PLUG	2				0.015	0.033
030	04811-00150	O RING	2				0	0
030	04817-00150	O RING	2		→		0.001	0.0022
035	04811-00200	O RING	1				0	0
035	04817-00200	O RING	1		→		0.011	0.0242
040	04811-00360	O RING	1				0	0
040	04817-00360	O RING	1		→		0.001	0.0022
050	15221-56280	PIN START SPRING	1				0.006	0.0132
060	05012-00612	PIN STRAIGHT	2				0.003	0.0066
070	17331-32610	SUPPORT OIL FILTER	1				0.275	0.605
080	17326-32620	GASKET NA	1				0.005	0.011
090	01123-50825	BOLT	3				0.013	0.0286
100	17331-32880	COVER	1				0.075	0.165
110	17331-32910	COMP BOLT	1				0.07	0.154
120	04811-00150	O RING	1				0	0
120	04817-00150	O RING	1		→		0.001	0.0022
125	17331-32900	BOLT	1				0.06	0.132
130	19202-96830	O RING	1				0.01	0.022
140	17326-04132	GASKET GEAR CASE	1				0.03	0.066
150	01123-50860	BOLT	3				0.002	0.0044
160	01153-50870	BOLT	3				0.026	0.0572
170	17367-91010	BOLT	2				0.005	0.011
180	01153-50880	BOLT	2				0.03	0.066
190	17367-91020	BOLT	3				0.035	0.077
200	17367-91030	BOLT	2				0.02	0.044
210	04512-60080	WASHER SPRING	5				0.002	0.0044
220	99999-99999	BLANK	0				0	0
230	15521-32290	JOINT PIPE	1	<=YW0578			0	0
230	15521-32293	JOINT PIPE	1	>=YY0001	→		0	0
240	15241-36950	SPRING	1				0.004	0.0088
250	15521-36930	SEAT VALVE	1				0.015	0.033
260	07715-03213	BALL	1				0.004	0.0088
270	15521-73320	FLANGE WATER RETURN	1				0.04	0.088
280	15766-73330	GASKET WATER FLANGE	1				0	0
280	1A021-73330	GASKET WATER FLANGE	1		«		0.001	0.0022
290	01023-50620	BOLT	3				0.006	0.0132
300	17321-32430	CARTRIDGE OIL FILTER	1				0	0
300	16414-32430	CARTRIDGE OIL FILTER	1		«		0.54	1.188
310	38240-34660	ASSY GEAR CASE H/M	1				0.335	0.737
320	15296-88130	GASKET H/METER DRIVE	1				0.002	0.0044
330	15221-88210	STUD	4				0.005	0.011
340	02056-50060	NUT	4				0.002	0.0044
350	04512-50060	WASHER SPRING	4				0	0
360	15571-33140	PLUG OIL FILLER	1	<=1L0119		NOT SALE	0.03	0.066
360	16427-33140	PLUG OIL FILLER	1	>=1N0001	→		0.025	0.055

WATER PUMP

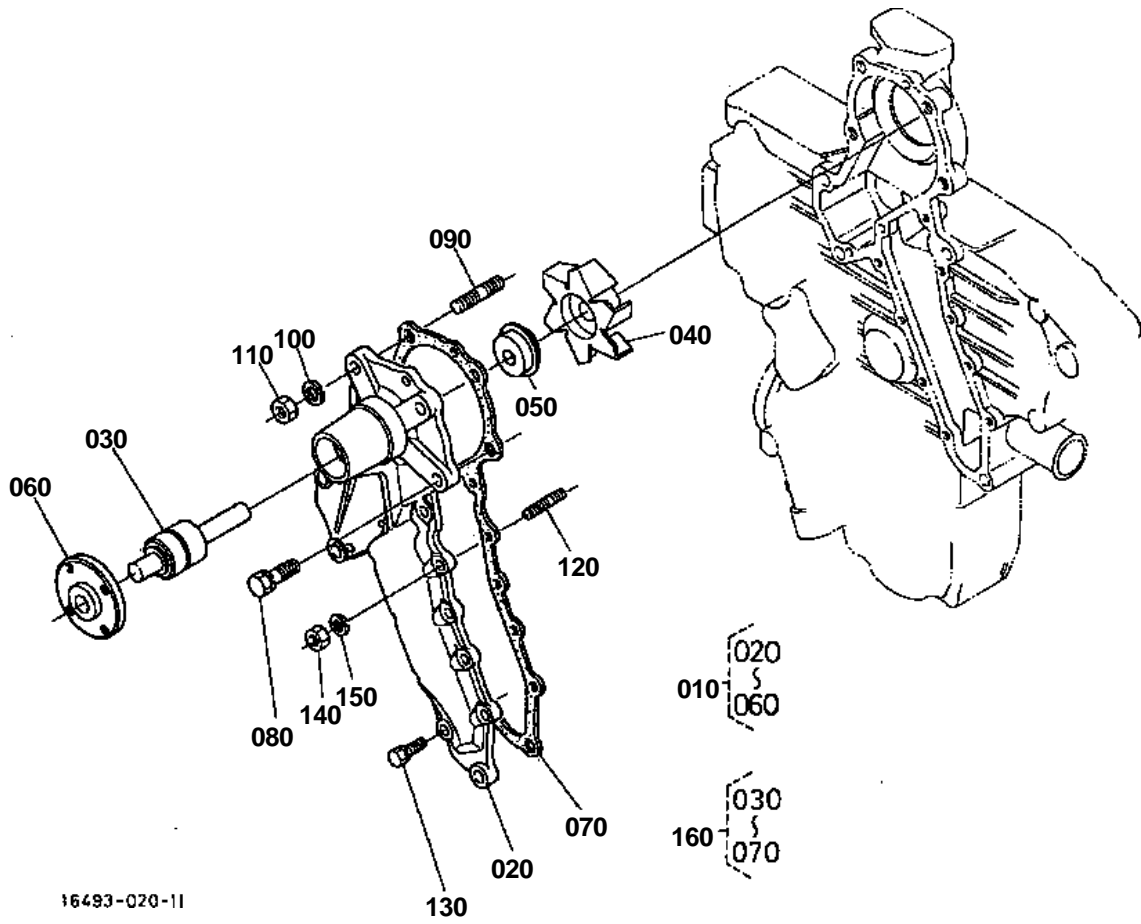

16493-020-11

040 16661-7351-0

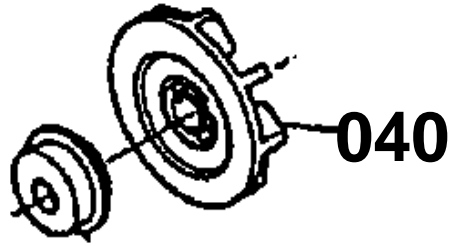

1G782-803-10



WATER PUMP

↔ Interchangeable; ≠ not interchangeable; ← new for old; → old for new

REF.No	Part No.	Description	Q'ty	S.No.	I/C	REMARKS	Weight (kgf)	Weight (lb)
010	16412-73030	ASSY PUMP WATER	1	<=1W0387			0	0
010	1A021-73030	ASSY PUMP WATER	1	>=1Y0001	—		1	2.2
020	17331-73410	BODY WATER PUMP	1				0.51	1.122
030	15521-73550	BEARING	1				0.235	0.517
040	15521-73510	IMPELLER WATER PUMP	1	<=4964			0.22	0.484
040	16661-73510	IMPELLER	1	>=4965	1		0	0
040	1A021-73510	IMPELLER WATER PUMP	1	>=1Y0001	—		0.065	0.143
050	19202-73050	ASSY SEAL MECHANICAL	1	<=4964			0.02	0.044
050	16661-73050	ASSY SEAL MECHANICAL	1	>=4965	1		0.025	0.055
060	15521-73520	FLANGE WATER PUMP	1				0.25	0.55
070	17326-73430	GASKET WATER PUMP	1				0	0
070	1A021-73430	GASKET WATER PUMP	1		«		0.007	0.0154
080	01123-50828	BOLT	3				0.014	0.0308
090	15521-91510	STUD	1	<=3U0554			0.012	0.0264
090	01518-50822	STUD	1	>=3W0001	—		0.012	0.0264
100	04512-60080	WASHER SPRING	1				0.002	0.0044
110	02156-50080	NUT	1				0.004	0.0088
120	15221-88210	STUD	1				0.005	0.011
130	01023-50618	BOLT	8				0.006	0.0132
140	02056-50060	NUT	1				0.002	0.0044
150	04512-60060	WASHER SPRING	1				0.001	0.0022
160	07916-27482	KIT REPAIR W/PUMP	1				0.71	1.562

WATER FLANGE AND THERMOSTAT

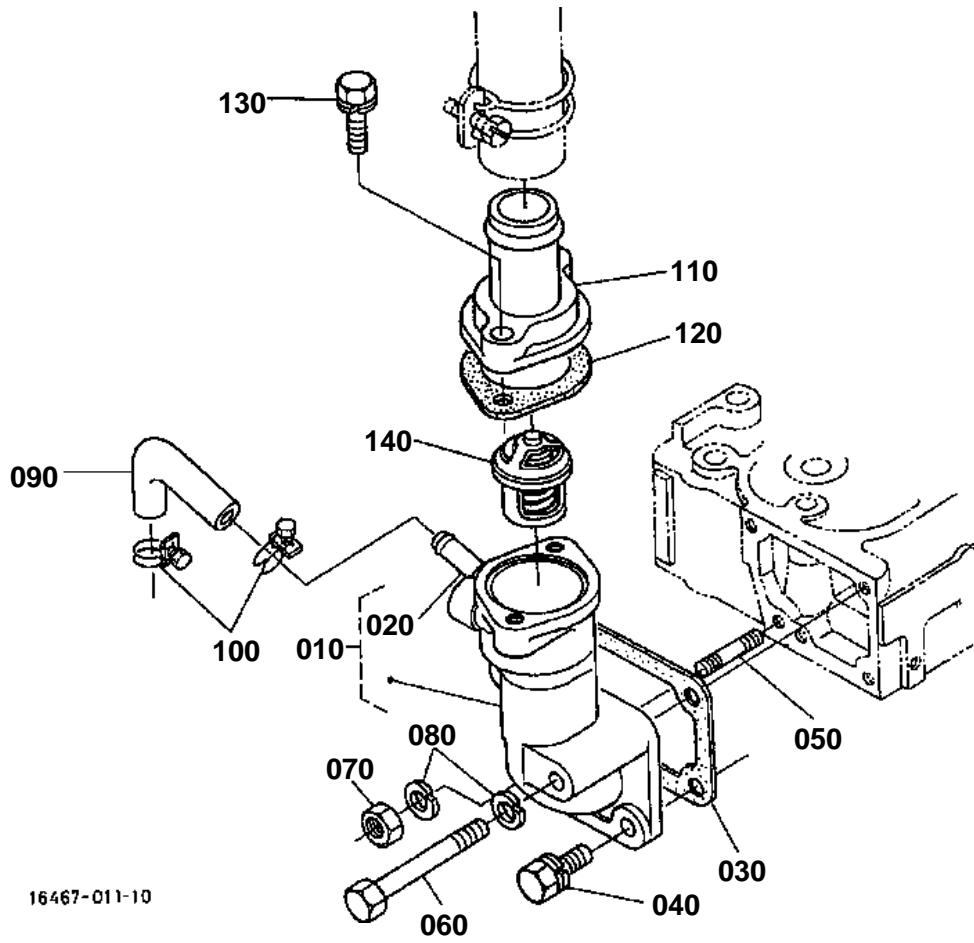

16467-011-10



WATER FLANGE AND THERMOSTAT

↔ Interchangeable; ≠ not interchangeable; ← new for old; → old for new

REF.No	Part No.	Description	Q'ty	S.No.	I/C	REMARKS	Weight (kgf)	Weight (lb)
010	16415-72702	COMP.FLANGE WATER	1				0.35	0.77
020	17331-73342	PIPE WATER RETURN	1				0.01	0.022
030	15766-72920	GASKET WATER FLANGE	1				0	0
030	1A021-72920	GASKET WATER FLANGE	1		«		0.002	0.0044
040	01123-50822	BOLT	2				0.012	0.0264
040	01123-50820	BOLT	2		«		0.011	0.0242
050	15221-91530	STUD	1				0.011	0.0242
060	01153-50870	BOLT	1				0.026	0.0572
070	02156-50080	NUT	1				0.004	0.0088
080	04512-50080	WASHER SPRING	2				0	0
090	15521-73340	PIPE WATER RETURN	1				0.025	0.055
090	1G369-73340	PIPE WATER RETURN	1		«		0.021	0.0462
100	15109-73360	BAND PIPE	2				0.01	0.022
110	15321-73260	COVER THERMOSTAT	1				0.107	0.2354
120	15313-73270	GASKET THERMOSTAT	1				0	0
120	1A021-73270	GASKET THERMOSTAT	1	<=2E0587	«		0	0
120	16221-73270	GASKET THERMOSTAT	1	>=2G0001	—		0.01	0.022
130	01123-50835	BOLT	2				0.02	0.044
140	19434-73010	ASSY THERMOSTAT	1	<=1A0204			0	0
140	19434-73014	ASSY THERMOSTAT	1	>=1C0001	—		0.07	0.154

FUEL CAMSHAFT

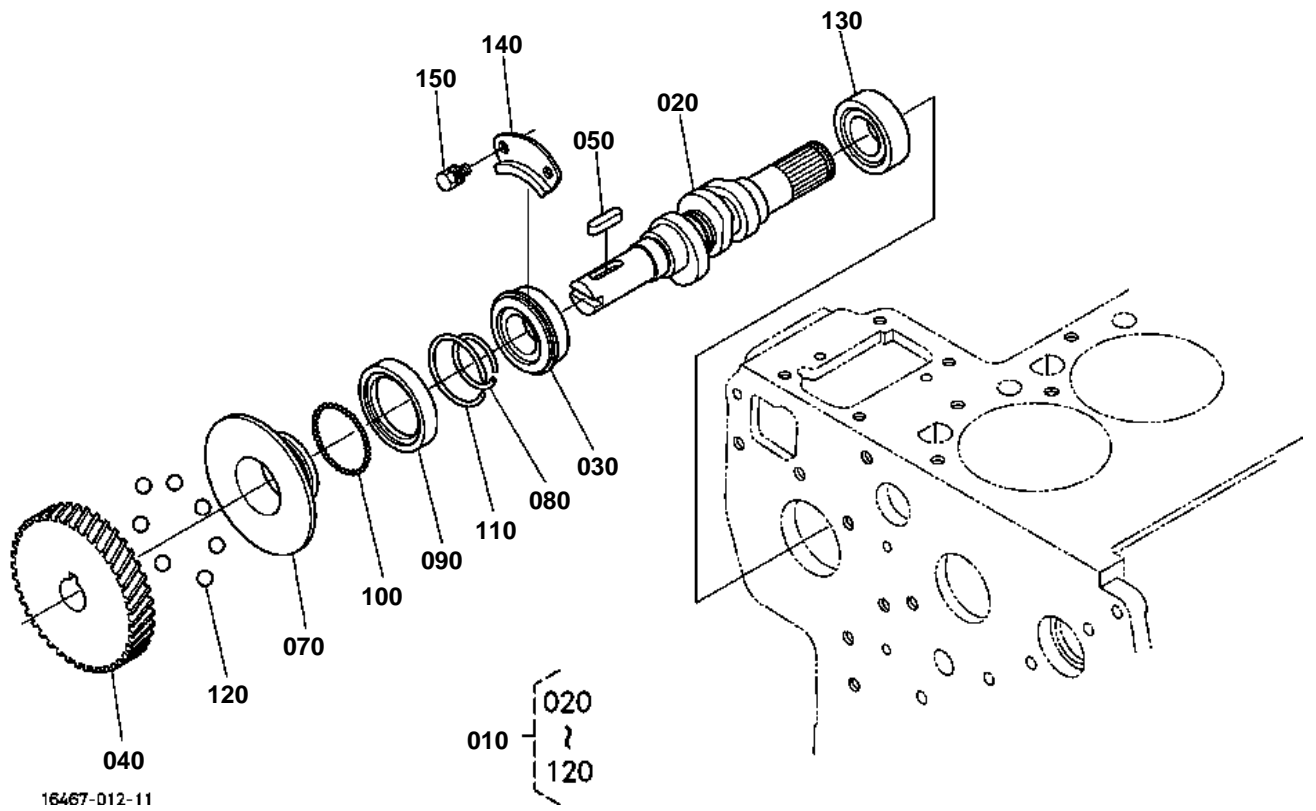

020 16427-1617-0

020 16427-1617-3

020

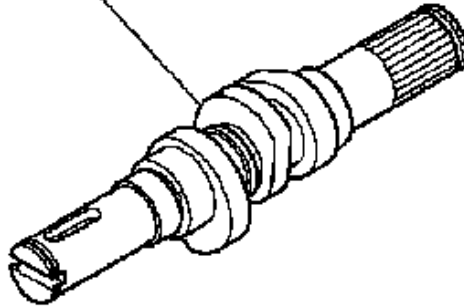

060 04612-00240

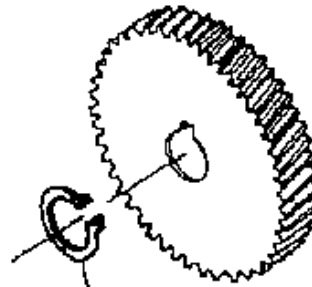

060

16467-818-10

**FUEL CAMSHAFT**

↔ Interchangeable; ≠ not interchangeable; ← new for old; → old for new

REF.No	Part No.	Description	Q'ty	S.No.	I/C	REMARKS	Weight (kgf)	Weight (lb)
010	16427-16020	ASSY CAMSHAFT FUEL	1				2.5	5.5
020	16427-16170	CAMSHAFT FUEL	1	<=7601			0	0
020	16427-16173	CAMSHAFT FUEL	1	>=7602	-		0.99	2.178
030	08153-06205	BEARING BALL	1				0.13	0.286
040	16415-51150	GEAR INJECTION PUMP	1				1.075	2.365
050	05712-00525	KEY FEATHER	1				0.005	0.011
060	04612-00240	CIRCLIP EXTERNAL	1	<=4E1597			0.002	0.0044
070	15611-55450	SLEEVE GOVERNOR	1				0.117	0.2574
080	15221-55470	CIR-CLIP GOV.SLEEVE	1				0.003	0.0066
090	15611-55690	CASE GOVERNOR BALL	1				0.03	0.066
100	07715-03205	BALL	39				0.001	0.0022
110	15221-55740	CIR-CLIP	1				0.002	0.0044
120	07715-00403	BALL	7				0.03	0.066
130	08103-06205	BEARING BALL	1	<=3U0554			0.12	0.264
130	1A021-97300	BEARING BALL	1	>=3W0001	1		0.125	0.275
140	15221-16320	STOPPER FUEL.C/SHAFT	1				0.02	0.044
150	01123-50814	BOLT	2				0	0

INJECTION PUMP

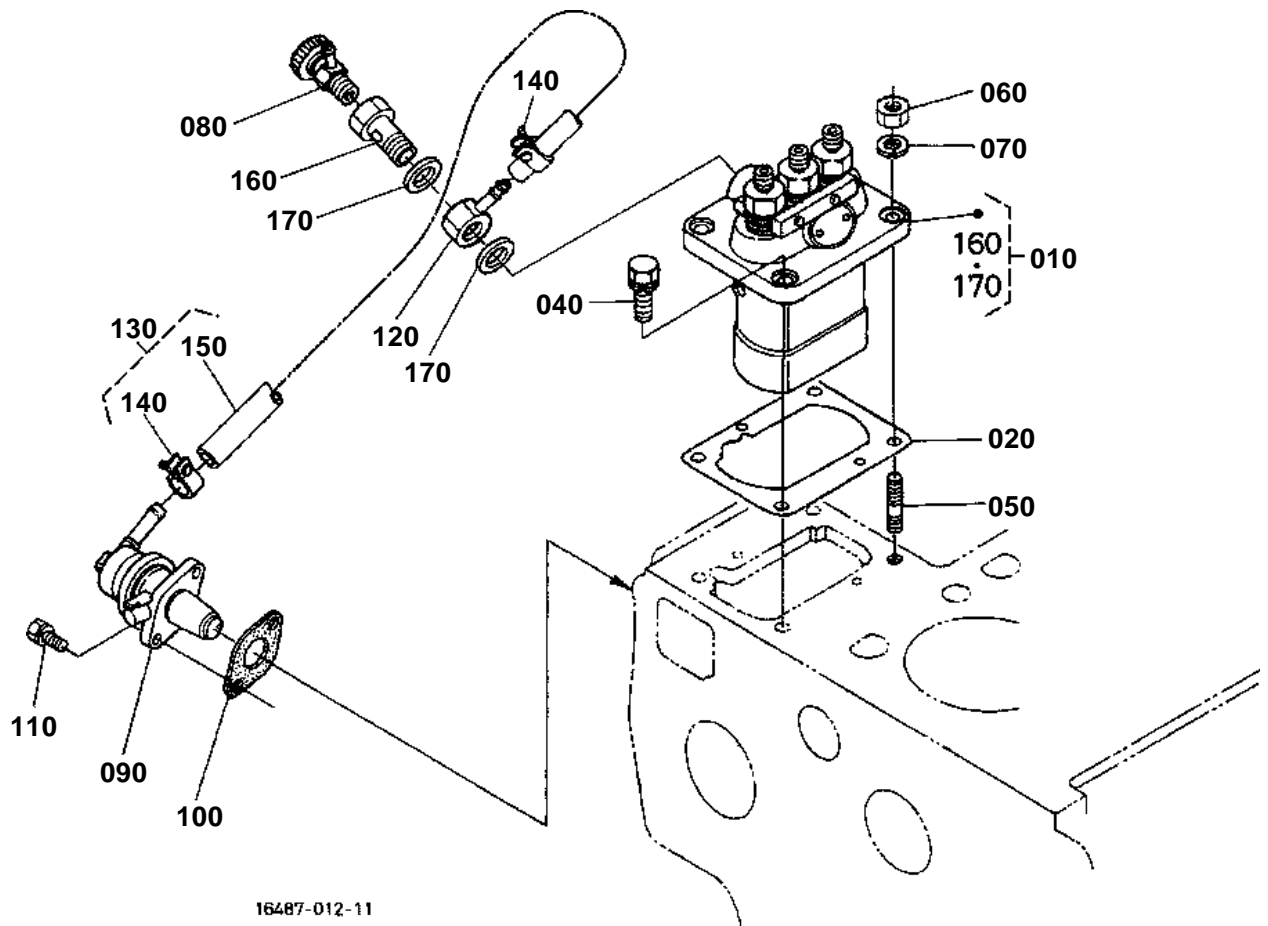



INJECTION PUMP

↔ Interchangeable; ≠ not interchangeable; ← new for old; → old for new

REF.No	Part No.	Description	Q'ty	S.No.	I/C	REMARKS	Weight (kgf)	Weight (lb)
010	16427-51010	ASSY PUMP INJECTION	1	<=11893			2.3	5.06
010	1G702-51010	ASSY PUMP INJECTION	1	>=XA0001	1		2.2	4.84
020	16414-52090	SHIM INJECTION	1			0.20mm	0.001	0.0022
020	16414-52110	SHIM INJECTION	1			0.25mm	0.001	0.0022
020	16414-52120	SHIM INJECTION	1			0.30mm	0.005	0.011
030	99999-99999	BLANK	0				0	0
040	01123-50822	BOLT	2				0.012	0.0264
050	15221-91530	STUD	2				0.011	0.0242
060	02156-50080	NUT	2				0.004	0.0088
070	04512-50080	WASHER SPRING	2				0	0
080	14311-60504	ASSY COCK JET START	1				0.034	0.0748
090	17121-52030	ASSY PUMP FUEL	1				0.13	0.286
100	15263-52140	GASKET FUEL PUMP	1				0	0
100	1A021-52140	GASKET FUEL PUMP	1		«		0.001	0.0022
110	01023-50616	BOLT	2				0.005	0.011
120	14111-42410	JOINT EYE	1				0.025	0.055
130	32751-35510	ASSY TUBE FUEL	1				0.045	0.099
140	14301-42750	CLIP PIPE	2				0.005	0.011
150	09661-80280	TUBE FUEL	1				0.033	0.0726
160	15521-51320	SCREW HOLLOW	1				0.035	0.077
170	15221-96650	GASKET	2				0.001	0.0022

ENGINE STOP LEVER

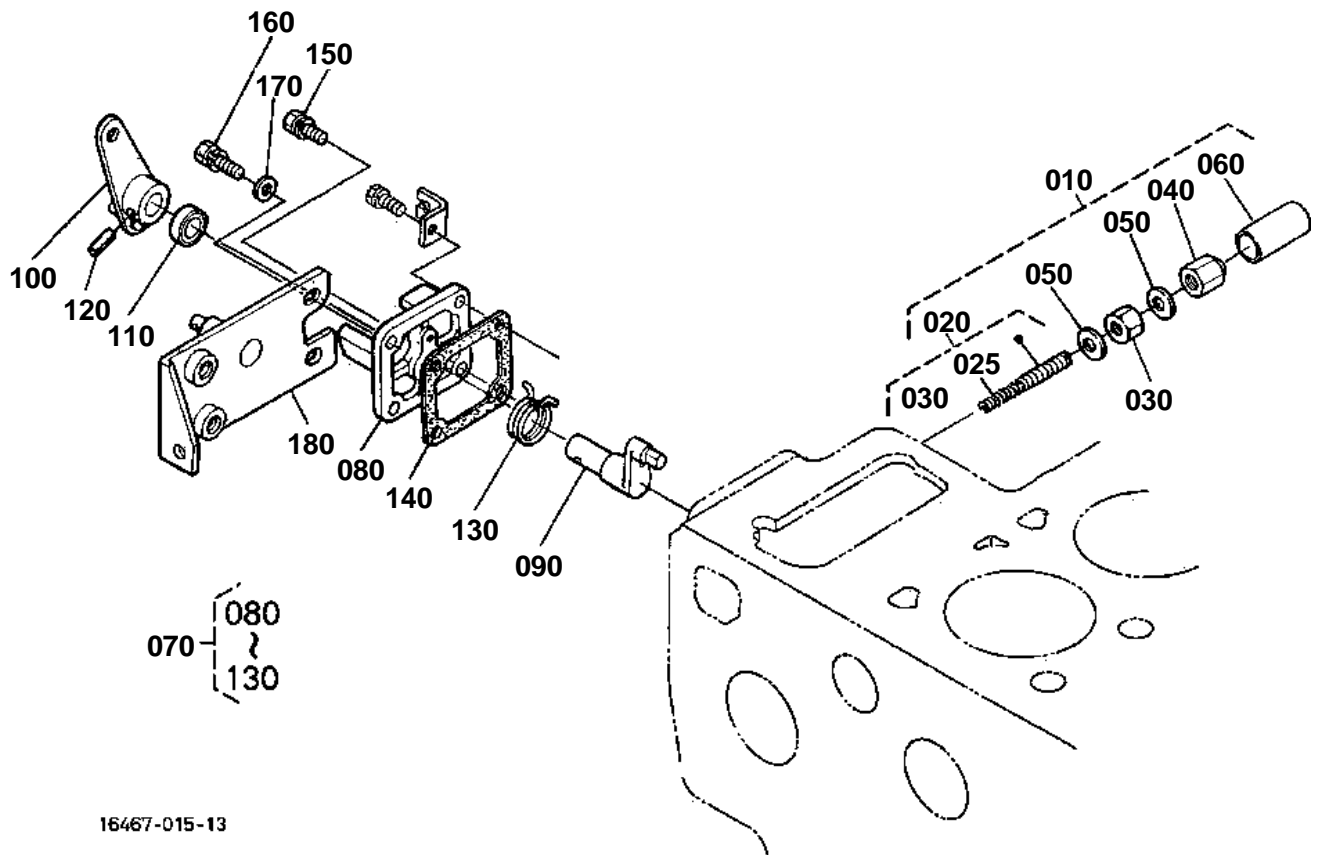

16467-015-13



ENGINE STOP LEVER

↔ Interchangeable; ≠ not interchangeable; ← new for old; → old for new

REF.No	Part No.	Description	Q'ty	S.No.	I/C	REMARKS	Weight (kgf)	Weight (lb)
010	15521-54090	APPARATUS IDLING	1				0.045	0.099
020	15521-54100	ASSY BOLT ADJUSTMENT	1	<=4G1515			0.015	0.033
020	15521-54103	ASSY BOLT ADJUSTMENT	1	>=4J0001	-		0.015	0.033
025	15521-54260	SPRING	1			NOT SALE	0.001	0.0022
030	15401-92010	NUT	1				0.01	0.022
040	15521-92330	NUT CAP	1				0.02	0.044
050	15021-33660	GASKET	2				0.001	0.0022
060	15521-54270	CAP	1				0.003	0.0066
070	17331-57702	ASSY LEVER ENG.STOP	1				0.19	0.418
080	15471-51652	COVER INJECTION PUMP	1				0.02	0.044
090	17331-57740	SHAFT LEVER	1				0.04	0.088
100	17331-57720	LEVER ENGINE STOP	1				0.05	0.11
110	15471-57980	SEAL OIL	1				0.001	0.0022
120	05411-00420	PIN SPRING	1				0.001	0.0022
130	15471-57920	SPRING RETURN	1				0.005	0.011
140	15296-51660	GASKET PUMP COVER	1	<=1N0150			0	0
140	1A021-51660	GASKET PUMP COVER	1	>=1Q0001	-		0.003	0.0066
150	01023-50618	BOLT	2				0.006	0.0132
160	01023-50622	BOLT	2				0.005	0.011
170	04012-50060	WASHER PLAIN	2				0.001	0.0022
180	16427-60110	SUPPORT SOLENOID	1				0.16	0.352

SPEED CONTROL PLATE

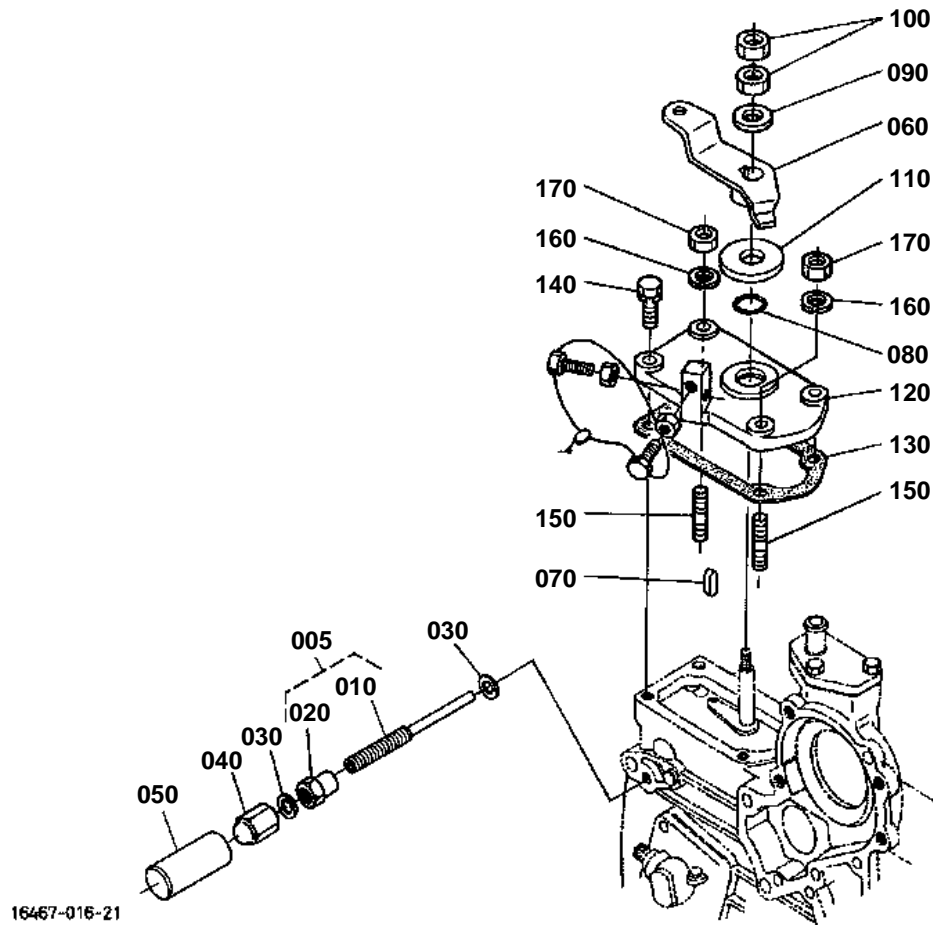

010 15601-5412-0

010

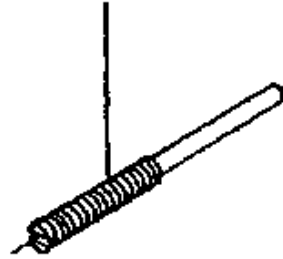

050 16221-5442-0

050

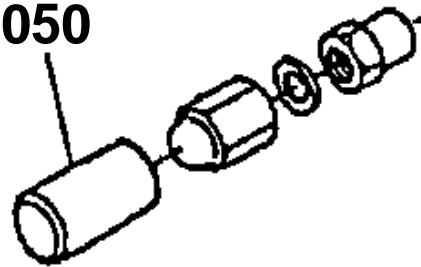

16467-810-11

**SPEED CONTROL PLATE**

↔ Interchangeable; ≠ not interchangeable; ← new for old; → old for new

REF.No	Part No.	Description	Q'ty	S.No.	I/C	REMARKS	Weight (kgf)	Weight (lb)
005	1A021-54350	ASSY BOLT ADJUSTMENT	1	>=2C0001			0.015	0.033
010	15601-54120	BOLT ADJUSTING	1	<=2A0506			0.011	0.0242
010	1A021-54120	BOLT ADJUSTING	1	>=2C0001	-		0.009	0.0198
020	15601-92010	NUT	1	<=10146			0	0
020	15601-92012	NUT	1	>=10147	-		0.006	0.0132
030	15601-96650	GASKET	2				0.001	0.0022
040	15841-14620	NUT CAP	1				0.01	0.022
050	16241-54420	CAP	1				0	0
050	16221-54420	CAP	1	<=11893	<<		0.001	0.0022
050	99999-99999	PIPE LOCK	1	>=XA0001	1		0	0
060	15469-57150	LEVER SPEED CONTROL	1				0.06	0.132
070	05712-00408	KEY FEATHER	1				0.001	0.0022
080	04811-00120	O RING	1				0	0
080	04817-00120	O RING	1		-		0.001	0.0022
090	04013-50080	WASHER PLAIN	1				0	0
100	02112-50080	NUT	2				0.003	0.0066
110	15521-57240	COLLAR	1				0.002	0.0044
120	15521-57114	PLATE SPEED CONTROL	1				0	0
120	15521-57115	PLATE SPEED CONTROL	1		<<		0.1	0.22
130	15439-57210	GASKET	1				0.005	0.011
140	01023-50625	BOLT	2				0.007	0.0154
150	15221-88210	STUD	2				0.005	0.011
160	04512-60060	WASHER SPRING	2				0.001	0.0022
170	02056-50060	NUT	2				0.002	0.0044

GOVERNOR

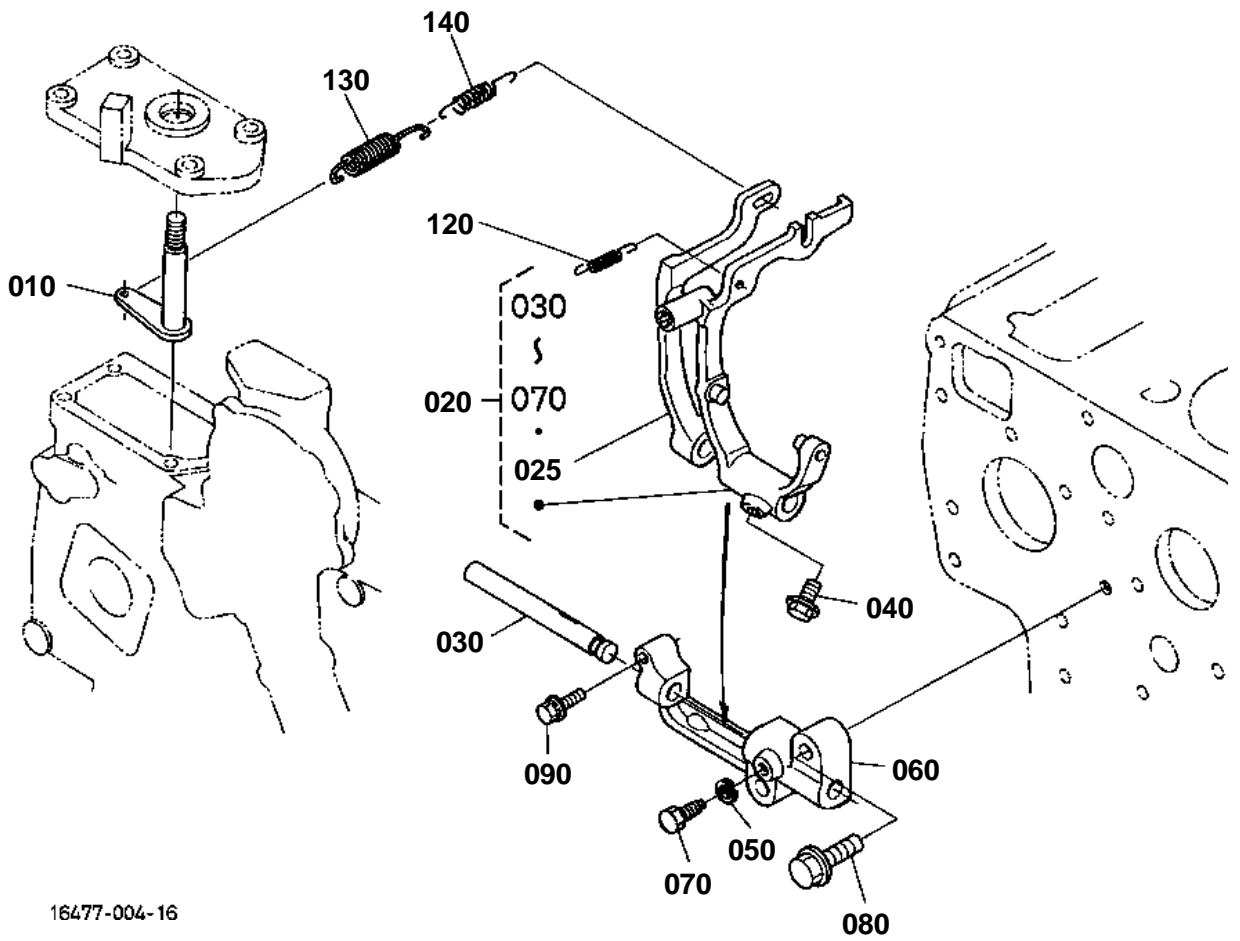

16477-004-16

040 15021-5624-0

050 04512-60060

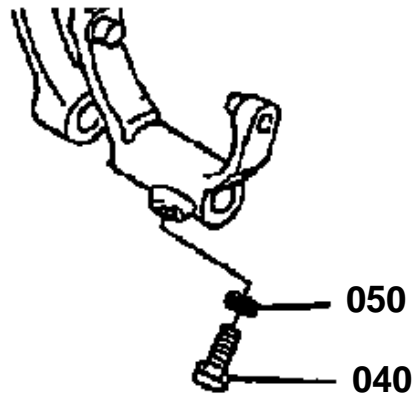

080 01123-50832

090 01023-50628

100 04012-50080

110 04012-50060

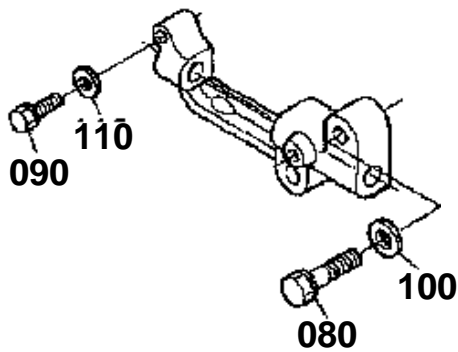

1G782-802-11

**GOVERNOR**

↔ Interchangeable; ≠ not interchangeable; ← new for old; → old for new

REF.No	Part No.	Description	Q'ty	S.No.	I/C	REMARKS	Weight (kgf)	Weight (lb)
010	15601-56020	COMP.LEVER GOVERNOR	1				0.055	0.121
020	16467-56052	ASSY LEVER FORK	1				0.42	0.924
025	17331-56130	LEVER FORK	1				0.065	0.143
030	15221-56150	SHAFT FORK LEVER	1	<=2A0506			0.1	0.22
030	1G911-56150	SHAFT FORK LEVER	1	>=2C0001	1		0.05	0.11
040	15021-56240	BOLT LEVER SHAFT	1	<=2A0506			0.005	0.011
040	01754-50618	BOLT FLANGE	1	>=2C0001	1		0.01	0.022
050	04512-50060	WASHER SPRING	2	<=2A0506			0	0
050	04512-60060	WASHER SPRING	1	>=2C0001			0.001	0.0022
060	15221-56230	HOLDER FORK LEVER	1				0.1	0.22
070	15221-66410	BOLT	1				0.005	0.011
080	01123-50832	BOLT	2	<=3Q0483			0.016	0.0352
080	01754-50830	BOLT FLANGE	2	>=3S0001	→		0.05	0.11
090	01023-50628	BOLT	1	<=3Q0483			0.015	0.033
090	01025-50630	BOLT	1	>=3S0001	→		0.009	0.0198
100	04012-50080	WASHER PLAIN	2	<=3Q0483			0.001	0.0022
110	04012-50060	WASHER PLAIN	1	<=3Q0483			0.001	0.0022
120	15611-56480	SPRING START	1				0.001	0.0022
130	19077-56410	SPRING GOVERNOR	1	<=8979			0	0
130	19077-56412	SPRING GOVERNOR	1	>=8980	→		0.01	0.022
140	16415-56420	SPRING GOVERNOR	1				0.002	0.0044

UPPER GASKET KIT

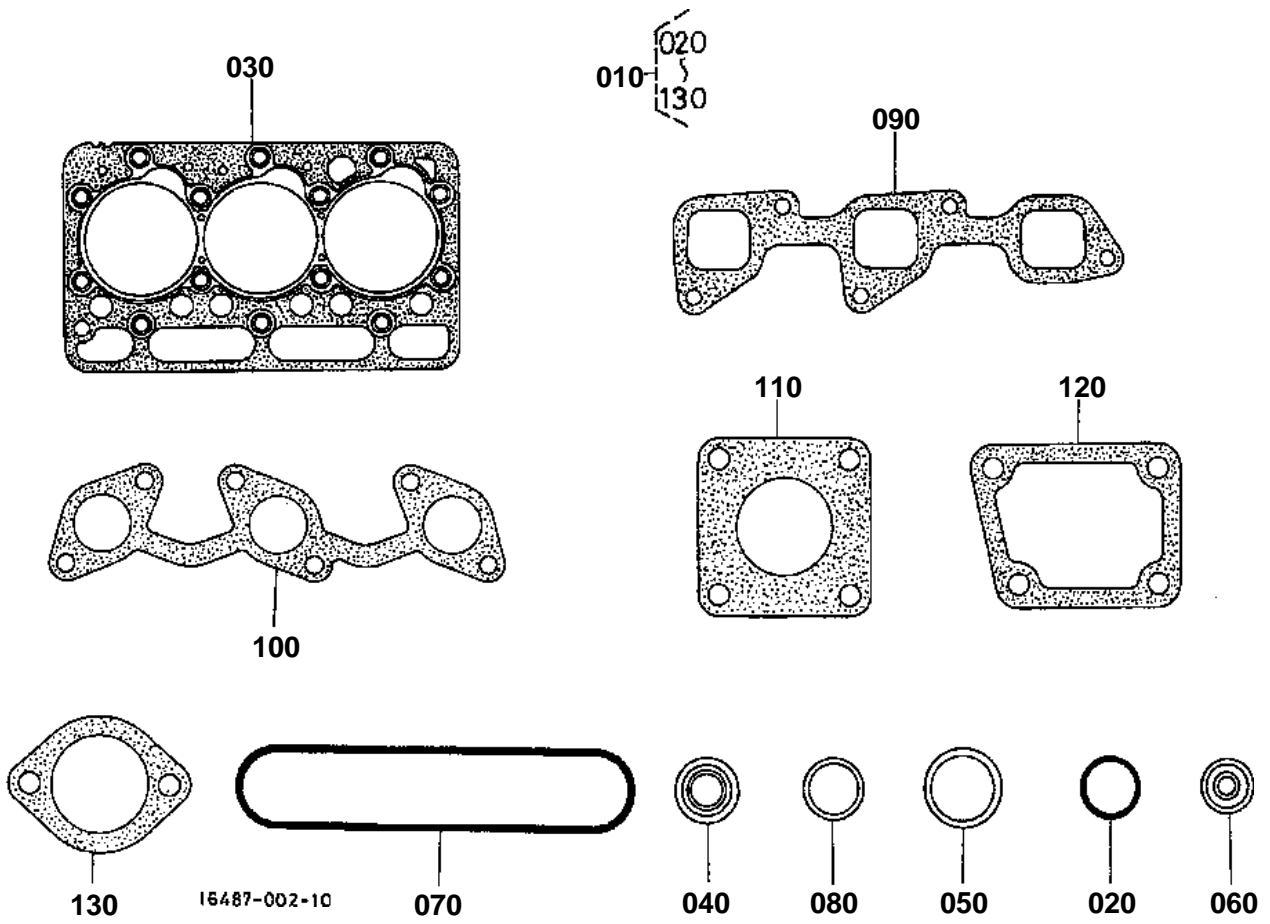

**UPPER GASKET KIT**

↔ Interchangeable; ≠ not interchangeable; ← new for old; → old for new

REF.No	Part No.	Description	Q'ty	S.No.	I/C	REMARKS	Weight (kgf)	Weight (lb)
010	07916-27710	KIT GASKET UPPER	1				0	0
010	07916-27715	KIT GASKET UPPER	1		—		0.35	0.77
020	15221-33700	O RING	1				0.001	0.0022
030	16487-03310	CASKET CYL.HEAD	1				0.105	0.231
040	15221-13150	SEAL VALVE STEM	6	<=3S0588			0.001	0.0022
040	15221-13153	SEAL VALVE STEM	6	>=3U0001	—		0.001	0.0022
050	15841-53620	GASKET	3				0	0
050	15841-53622	GASKET	3		«		0.002	0.0044
060	19077-53650	SEAL HEAT	3				0.005	0.011
070	15521-14520	GASKET HEAD COVER	1	<=3W0593			0.035	0.077
070	1A021-14520	GASKET HEAD COVER	1	>=3Y0001	1		0	0
080	15021-33660	GASKET	3				0.001	0.0022
090	17326-11820	GASKET IN-MANIFOLD	1	<=2S0315			0	0
090	1A021-11822	GASKET IN-MANIFOLD	1	>=2U0001	—		0.006	0.0132
100	15313-12350	GASKET EX-MANIFOLD	1				0.04	0.088
100	1A021-12350	GASKET EX-MANIFOLD	1		«		0.028	0.0616
110	T0070-16420	GASKET MUFFLER	1				0.016	0.0352
120	15766-72920	GASKET WATER FLANGE	1				0	0
120	1A021-72920	GASKET WATER FLANGE	1		«		0.002	0.0044
130	15313-73270	GASKET THERMOSTAT	1				0	0
130	1A021-73270	GASKET THERMOSTAT	1	<=2E0587	«		0	0
130	16221-73270	GASKET THERMOSTAT	1	>=2G0001	—		0.01	0.022

LOWER GASKET KIT

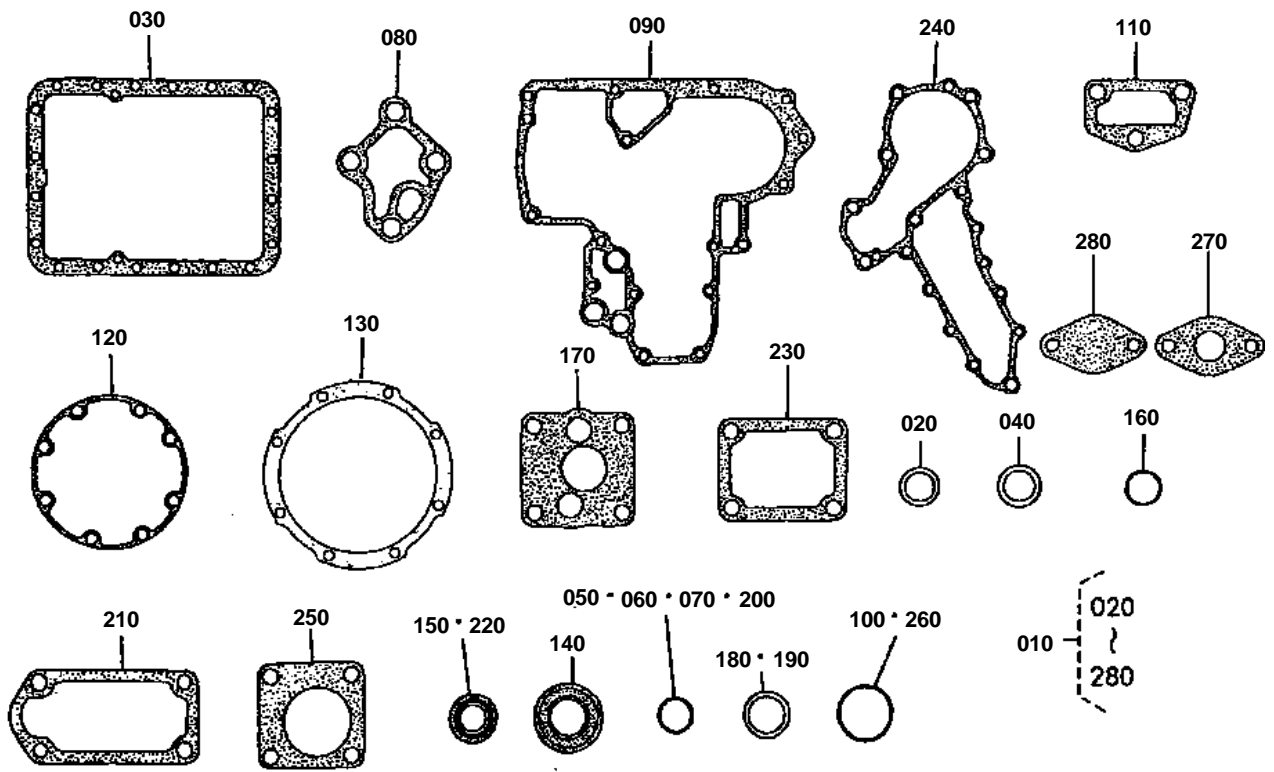

1G7 22-008-11

130 17118-0483-0

130

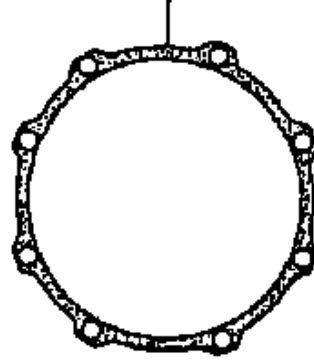

1A021-805-10



LOWER GASKET KIT

↔ Interchangeable; ≠ not interchangeable; ← new for old; → old for new

REF.No	Part No.	Description	Q'ty	S.No.	I/C	REMARKS	Weight (kgf)	Weight (lb)
010	07916-27720	KIT GASKET LOWER	1				0	0
010	07916-27725	KIT GASKET LOWER	1		→		0	0
010	07916-27726	KIT GASKET LOWER	1		→		0	0
010	07916-27727	KIT GASKET LOWER	1		→		0.285	0.627
020	15021-33660	GASKET	3				0.001	0.0022
030	17326-01620	GASKET OIL PAN	1				0	0
030	1A021-01620	GASKET OIL PAN	1		«		0.014	0.0308
040	15109-33660	GASKET	2				0.001	0.0022
040	6C090-58960	GASKET	2		«		0.002	0.0044
050	04811-00160	O RING	1				0	0
050	04817-00160	O RING	1		→		0.001	0.0022
060	04811-00150	O RING	2				0	0
060	04817-00150	O RING	2		→		0.001	0.0022
070	04811-00200	O RING	1				0	0
070	04817-00200	O RING	1		→		0.011	0.0242
080	17326-32620	GASKET	1				0.005	0.011
090	17326-04132	GASKET GEAR CASE	1				0.03	0.066
100	04811-00360	O RING	1				0	0
100	04817-00360	O RING	1		→		0.001	0.0022
110	15766-73330	GASKET WATER FLANGE	1	<=1U0323			0	0
110	1A021-73330	GASKET WATER FLANGE	1	>=1W0001	→		0.001	0.0022
120	17118-04360	GASKET BEARING CASE	1				0	0
120	19077-04360	GASKET BRG.CASE	1	<=2Y0733	«		0	0
120	1A091-04360	GASKET BEARING CASE	1	>=3A0001	1		0	0
120	1A091-04362	GASKET BEARING CASE	1	>=3Q0001	→		0.005	0.011
130	17118-04830	GASKET CASE COVER	1				0	0
130	1A091-04820	GASKET BRG.CASE COV.	1		«		0.006	0.0132
140	19202-04460	SEAL OIL	1				0.055	0.121
150	19202-04140	SEAL OIL	1				0.015	0.033
160	04811-10300	O RING	1				0.001	0.0022
170	15296-35150	GASKET OIL PUMP	1				0	0
170	1A021-35150	GASKET OIL PUMP	1		«		0.001	0.0022
180	15221-96650	GASKET	2				0.001	0.0022
190	15601-96650	GASKET	2				0.001	0.0022
200	04811-00120	O RING	1				0	0
200	04817-00120	O RING	1		→		0.001	0.0022
210	15439-57210	GASKET	1				0.005	0.011
220	15471-57980	SEAL OIL	1				0.001	0.0022
230	15296-51660	GASKET PUMP COVER	1	<=1N0150			0	0
230	1A021-51660	GASKET PUMP COVER	1	>=1Q0001	→		0.003	0.0066
240	17326-73430	GASKET WATER PUMP	1				0	0
240	1A021-73430	GASKET WATER PUMP	1		«		0.007	0.0154
250	15296-88130	GASKET H/METER DRIVE	1				0.002	0.0044
260	19202-96830	O RING	1				0.01	0.022
270	15263-52140	GASKET FUEL PUMP	1				0	0
270	1A021-52140	GASKET FUEL PUMP	1		«		0.001	0.0022
280	15521-04790	PACKING COVER	1				0.005	0.011

STOP SELENOID AND ENGINE STOP WIRE

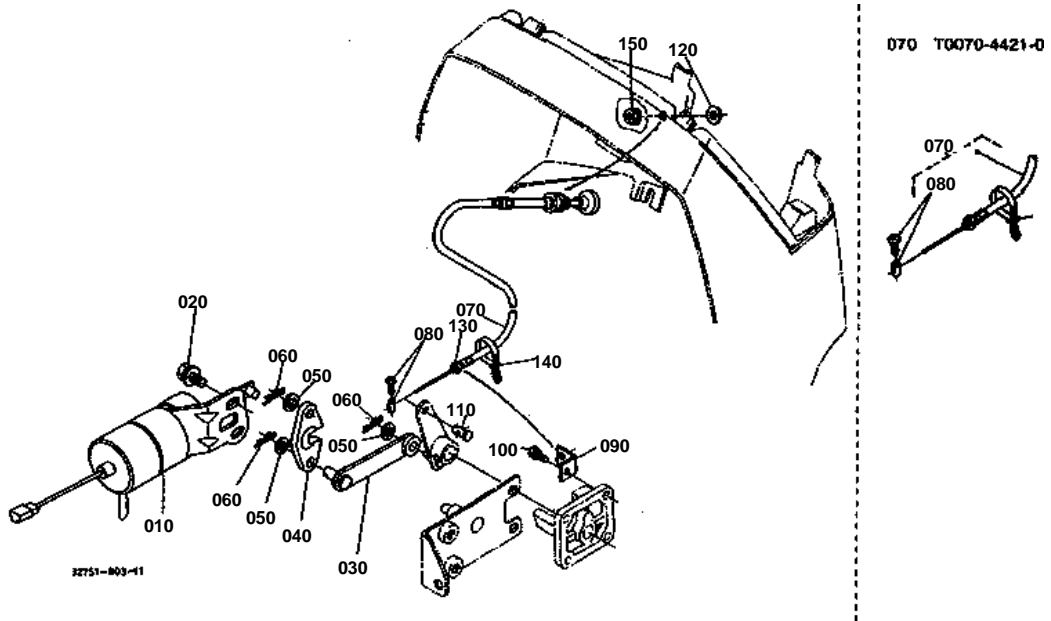

070 T0070-4421-0

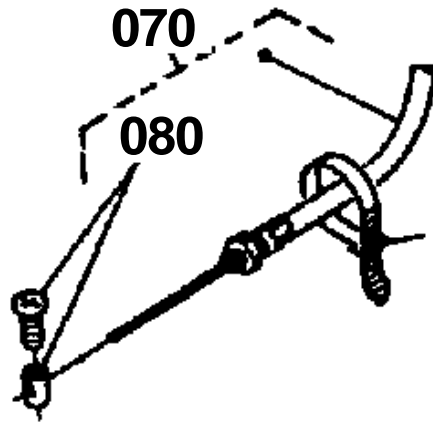

32751-801-10



STOP SOLENOID AND ENGINE STOP WIRE

↔ Interchangeable; ≠ not interchangeable; ← new for old; → old for new

REF.No	Part No.	Description	Q'ty	S.No.	I/C	REMARKS	Weight (kgf)	Weight (lb)
010	15471-60010	SOLENOID STOP	1				0.35	0.77
020	01125-60816	BOLT	2				0.01	0.022
030	17331-60150	LEVER STOP	1				0.025	0.055
040	15471-60162	LEVER STOP	1				0.007	0.0154
050	04012-50060	WASHER PLAIN	3				0.001	0.0022
060	05525-50600	PIN SNAP	3				0	0
070	T0070-44210	WIRE ENGINE STOP	1	<=63557			0.11	0.242
070	T0070-44214	WIRE ENGINE STOP	1	>=63558	®		0.11	0.242
080	T0070-44260	SCREW	1				0.005	0.011
090	34070-44220	HOLDER WIRE	1				0.02	0.044
100	01023-50620	BOLT	1				0.006	0.0132
110	34070-44240	PIN JOINT	1				0.005	0.011
120	04011-50100	WASHER PLAIN	1				0.002	0.0044
130	02012-60060	NUT	1	>=60895			0.005	0.011
140	53581-64150	BAND CORD	1				0.002	0.0044
150	02771-60100	NUT FLANGE	1				0.01	0.022

ACCELERATOR LEVER

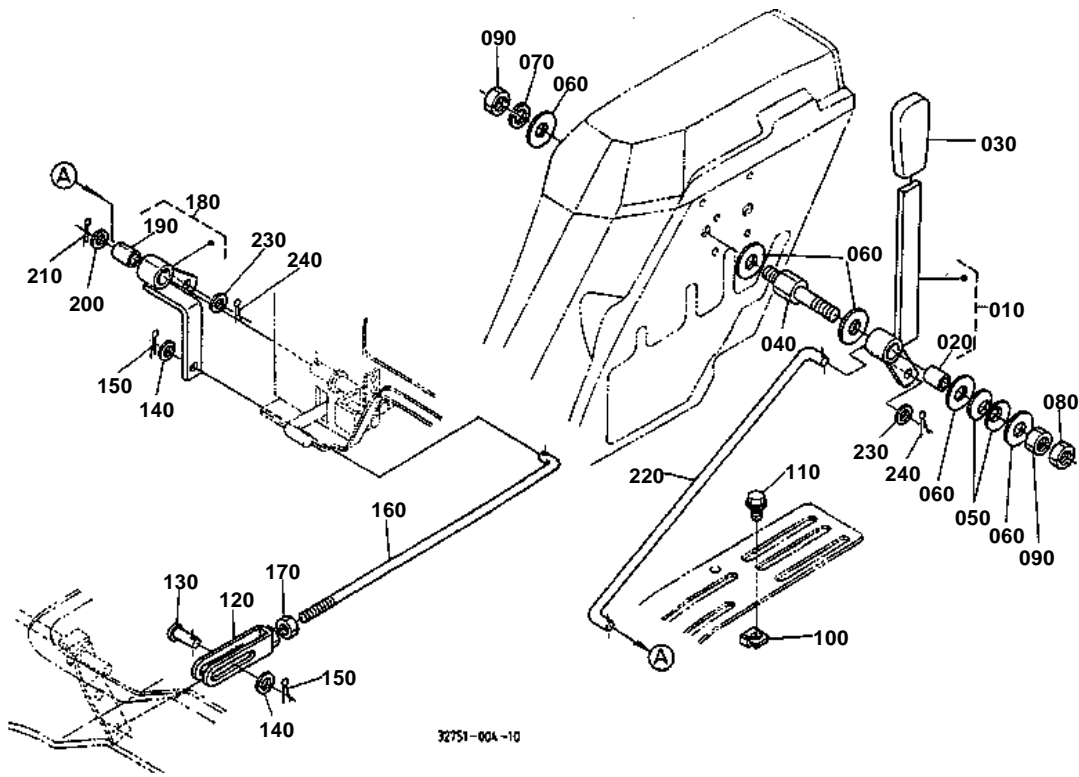



ACCELERATOR LEVER

↔ Interchangeable; ≠ not interchangeable; ← new for old; → old for new

REF.No	Part No.	Description	Q'ty	S.No.	I/C	REMARKS	Weight (kgf)	Weight (lb)
010	32751-42850	ASSY LEVER ACCEL	1				0.277	0.6094
020	08511-01220	BUSH	1				0.004	0.0088
030	TA040-24490	GRIP LEVER	1				0.033	0.0726
040	32701-44772	SHAFT ACCEL.LEVER	1				0.095	0.209
050	67800-44720	SPRING	2				0.005	0.011
060	04015-50120	WASHER PLAIN	5				0	0
070	04512-50120	WASHER SPRING	1				0	0
080	02172-50120	NUT	1				0.01	0.022
090	02174-50120	NUT	2				0.01	0.022
100	34070-36140	STOPPER	1				0.005	0.011
100	34070-36140	STOPPER	1		«		0.005	0.011
110	01754-50616	BOLT FLANGE	1				0.006	0.0132
120	32751-42870	U JOINT	1				0.06	0.132
130	05122-50620	PIN JOINT	1				0.005	0.011
140	04012-50060	WASHER PLAIN	2				0.001	0.0022
150	05511-51610	PIN SPLIT	2				0.001	0.0022
160	32751-42820	ROD ACCEL.	1				0.057	0.1254
170	02014-50060	NUT	1				0.002	0.0044
180	32751-42830	ASSY LEVER ACCEL.ROD	1				0.15	0.33
190	08511-01220	BUSH	1				0.004	0.0088
200	04011-50120	WASHER PLAIN	1				0.005	0.011
210	05511-50320	PIN SPLIT	1				0.002	0.0044
220	32751-42840	ROD ACCEL.	1				0.093	0.2046
230	04012-50060	WASHER PLAIN	2				0.001	0.0022
240	05511-51610	PIN SPLIT	2				0.001	0.0022

ACCELERATOR LINKAGE

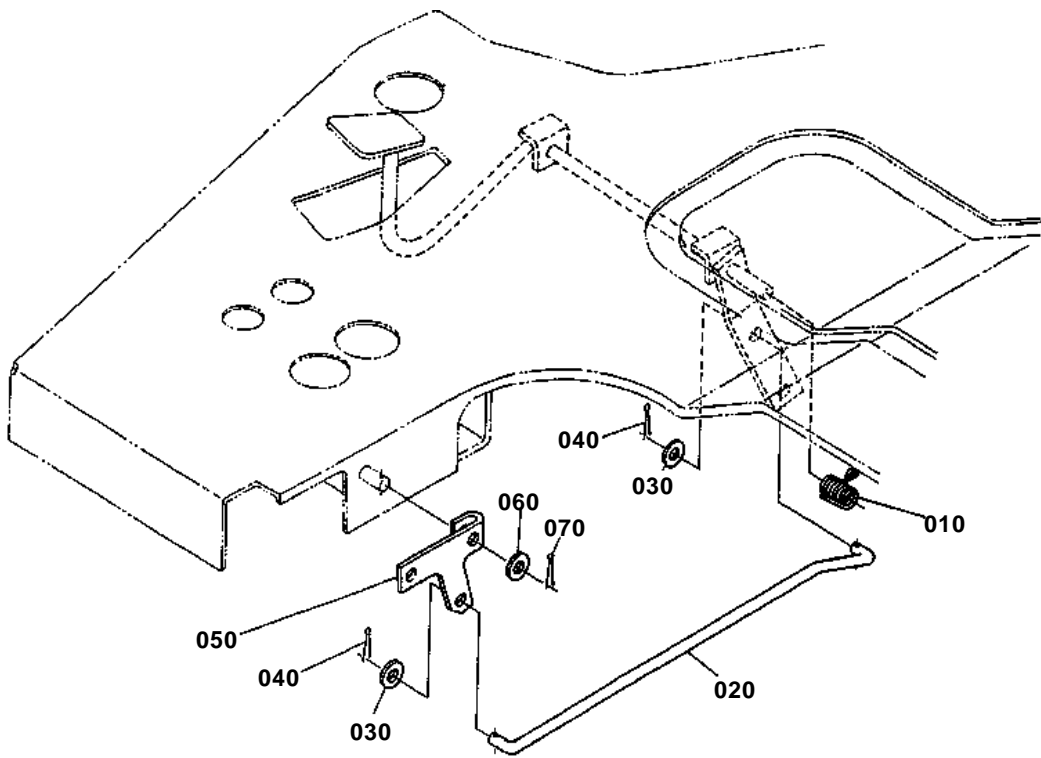

32751-005-10



ACCELERATOR LINKAGE

↔ Interchangeable; ≠ not interchangeable; ← new for old; → old for new

REF.No	Part No.	Description	Q'ty	S.No.	I/C	REMARKS	Weight (kgf)	Weight (lb)
010	T0070-44720	SPRING	1				0.015	0.033
020	T0070-44730	ROD ACCEL.	1				0.075	0.165
030	04012-50060	WASHER PLAIN	2				0.001	0.0022
040	05511-50218	PIN SPLIT	2				0.001	0.0022
050	34070-44740	LEVER ACCEL.	1	<=60189			0	0
050	34070-44744	LEVER ACCEL.	1	>=60190	-		0.045	0.099
060	04012-50060	WASHER PLAIN	1				0.001	0.0022
070	05511-51612	PIN SPLIT	1				0.001	0.0022

ACCELERATOR ROD

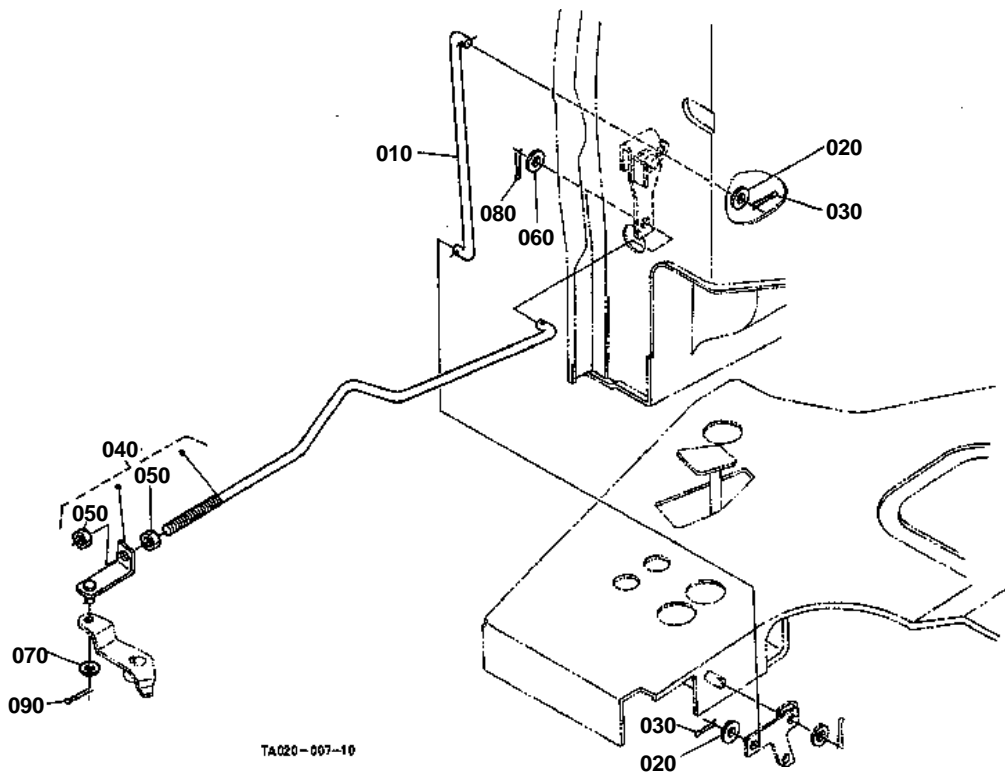



ACCELERATOR ROD

↔ Interchangeable; ≠ not interchangeable; ← new for old; → old for new

REF.No	Part No.	Description	Q'ty	S.No.	I/C	REMARKS	Weight (kgf)	Weight (lb)
010	34070-42920	ROD PEDAL	1				0.065	0.143
020	04012-50060	WASHER PLAIN	2				0.001	0.0022
030	05511-50218	PIN SPLIT	2				0.001	0.0022
040	TA020-42900	ASSY ROD ACCEL.	1				0.217	0.4774
050	02112-50080	NUT	2				0.003	0.0066
060	04012-50080	WASHER PLAIN	1				0.001	0.0022
070	04012-50060	WASHER PLAIN	1				0.001	0.0022
080	05511-50218	PIN SPLIT	1				0.001	0.0022
090	05511-51612	PIN SPLIT	1				0.001	0.0022

FUEL TANK

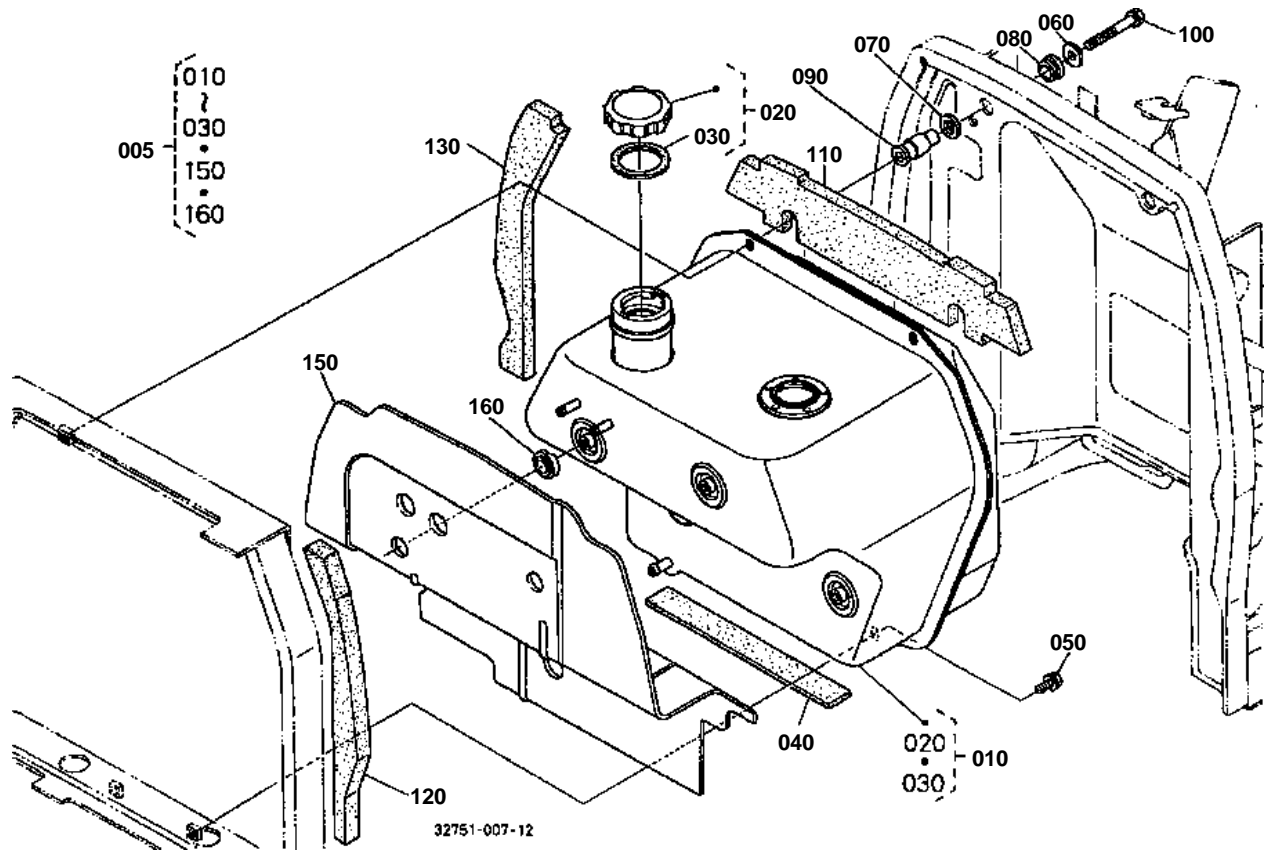

- 010 TA040-4200-0
- 010 TA040-4200-2
- 010 TA040-4200-3
- 010 TA040-4200-4
- 010 TA040-4200-5
- 010 TA040-4200-6

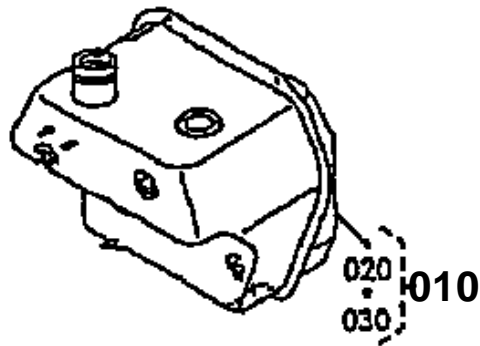

050 01754-50812

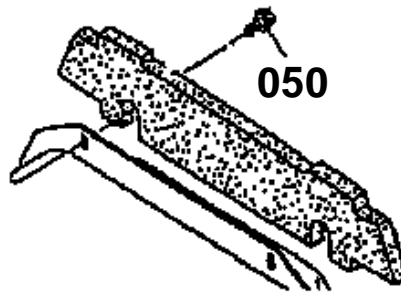

150 32751-4211-0

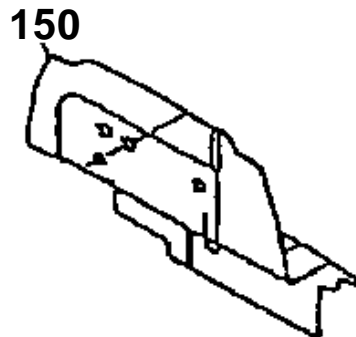

32751-817-11

**FUEL TANK**

↔ Interchangeable; ≠ not interchangeable; ← new for old; → old for new

REF.No	Part No.	Description	Q'ty	S.No.	I/C	REMARKS	Weight (kgf)	Weight (lb)
005	32751-94400	KIT FUEL TANK	1	<=72038			9.9	21.78
010	TA040-42000	ASSY TANK FUEL	1	<=60084		NOT SALE ORDER BY REF.No.005	0	0
010	TA040-42002	ASSY TANK FUEL	1	>=60085	→	NOT SALE ORDER BY REF.No.005	0	0
010	TA040-42003	ASSY TANK FUEL	1	>=60286	→	NOT SALE ORDER BY REF.No.005	0	0
010	TA040-42004	ASSY TANK FUEL	1	>=64504	→	NOT SALE ORDER BY REF.No.005	7	15.4
010	TA040-42005	ASSY TANK FUEL	1	>=71810	→	NOT SALE ORDER BY REF.No.005	7	15.4
010	TA040-42006	ASSY TANK FUEL	1	>=71954	→	NOT SALE ORDER BY REF.No.005	7	15.4
010	TA040-42007	ASSY TANK FUEL	1	>=72039	→	NOT SALE ORDER BY REF.No.005	7	15.4
020	61191-54720	ASSY CAP FUEL TANK	1				0.09	0.198
030	61191-54740	GASKET TANK CAP	1				0.01	0.022
040	31351-13820	CUSHION BATTERY	1				0.015	0.033
050	01754-50812	BOLT FLANGE	4	<=50007			0.01	0.022
050	01754-50812	BOLT FLANGE	2	>=50008			0.01	0.022
060	04015-60080	WASHER PLAIN	2	>=50008			0.01	0.022
070	04011-50140	WASHER PLAIN	2	>=50008			0.007	0.0154
080	34070-42060	CUSHION	2	>=50008			0.005	0.011
090	34070-42070	SPACER	2	>=50008			0.07	0.154
100	01123-50875	BOLT	2	>=50008			0.04	0.088
110	T0070-42510	SHUTTER	1	<=61617			0	0
110	T0070-42512	SHUTTER	1	>=61618	→		0	0
110	T0070-42513	SHUTTER	1	>=61970	→		0.03	0.066
120	T0070-42520	SHUTTER	1	<=61617			0	0
120	T0070-42523	SHUTTER	1	>=61618	→		0.019	0.0418
130	T0070-42530	SHUTTER	1	<=61617			0	0
130	T0070-42532	SHUTTER	1	>=61618	→		0.015	0.033
140	99999-99999	BLANK	0				0	0
150	32751-42110	PLATE SHUTTER	1	<=72038		NOT SALE ORDER BY REF.No.005	3.1	6.82
150	32751-42112	PLATE SHUTTER	1	>=72039	→		3.1	6.82
160	34070-42260	CUSHION	4				0.005	0.011

FUEL FILTER AND FUEL PIPE

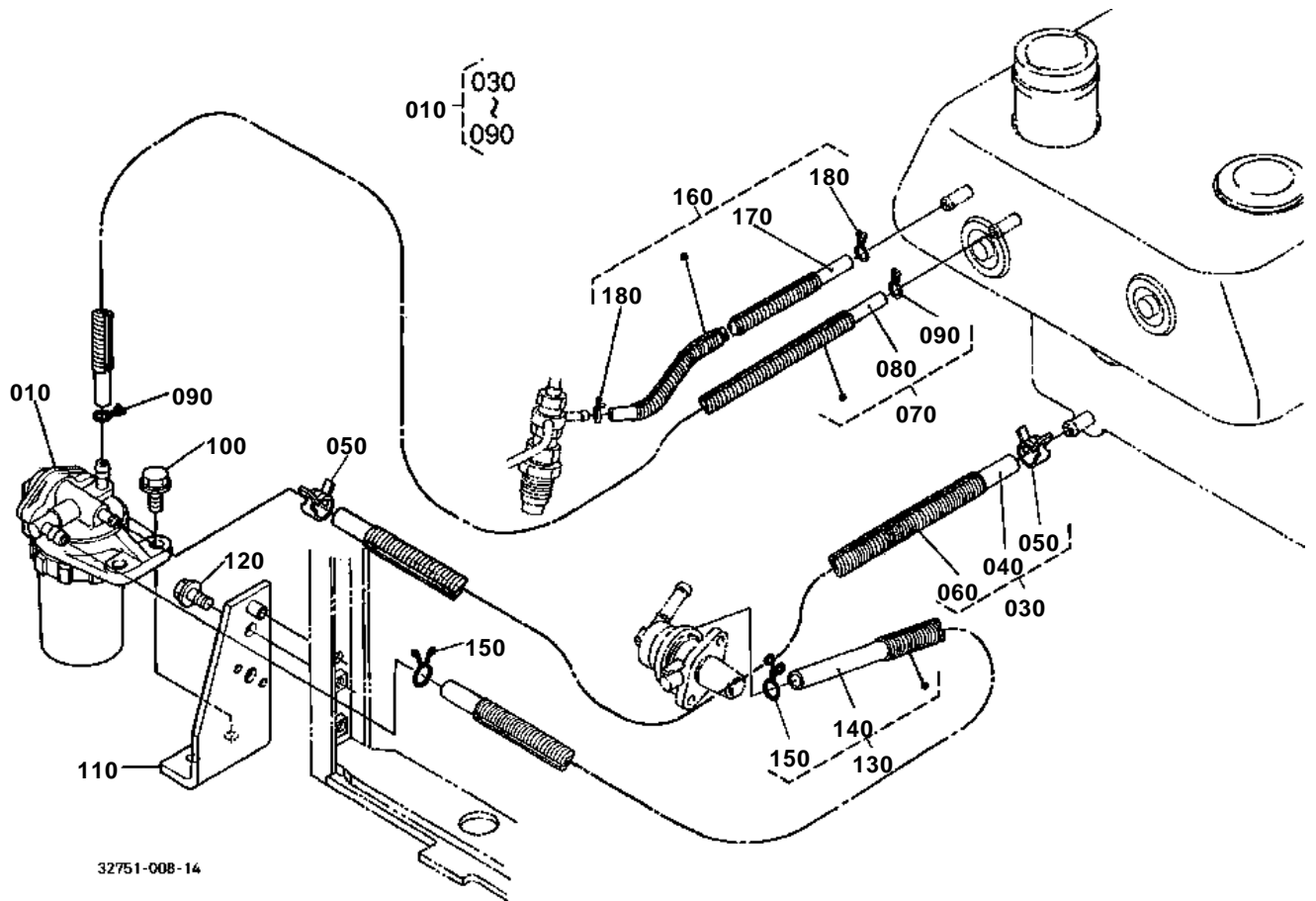

100 01123-50822

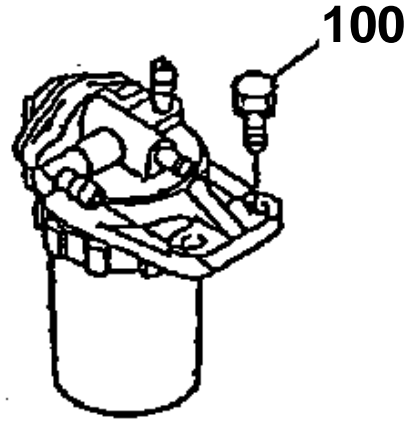

150 14301-4275-0

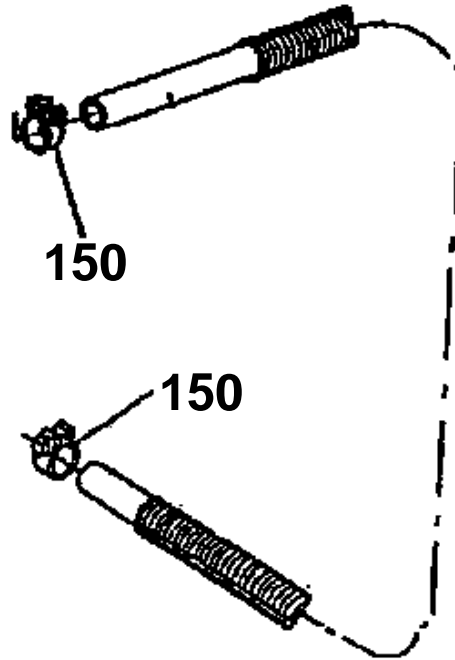

32751-815-11



FUEL FILTER AND FUEL PIPE

↔ Interchangeable; ≠ not interchangeable; ← new for old; → old for new

REF.No	Part No.	Description	Q'ty	S.No.	I/C	REMARKS	Weight (kgf)	Weight (lb)
010	19271-43010	ASSY FILTER FUEL	1				0	0
010	15521-43015	ASSY FILTER FUEL	1		«		0.59	1.298
020	99999-99999	BLANK	0				0	0
030	34530-42620	ASSY TUBE FUEL	1				0.055	0.121
040	09661-80300	TUBE FUEL	1				0.04	0.088
050	14301-42750	CLIP PIPE	2	<=71695			0.005	0.011
050	09318-88125	CLIP	2	>=71696	—		0.001	0.0022
060	34530-42670	TUBE	1				0.01	0.022
070	32751-42640	ASSY TUBE FUEL	1				0.06	0.132
080	09661-50750	TUBE FUEL	1				0	0
090	14971-42750	CLIP PIPE	2				0.001	0.0022
100	01123-50822	BOLT	2	<=70618			0.012	0.0264
100	01754-50825	BOLT FLANGE	2	>=70619	—		0.01	0.022
110	32751-42350	BRACKET FUEL FILTER	1				0.4	0.88
120	01754-50816	BOLT FLANGE	1				0.011	0.0242
130	34070-42623	ASSY TUBE FUEL	1	<=50007			0	0
130	34070-42624	ASSY TUBE FUEL	1	>=50008	—		0.095	0.209
130	34070-42650	ASSY TUBE FUEL	1	>=72643	1		0.093	0.2046
140	09661-80600	TUBE FUEL	1				0.08	0.176
150	14301-42750	CLIP PIPE	2	<=72642			0.005	0.011
150	14911-42750	CLIP PIPE	2	>=72643	—		0.002	0.0044
160	34070-42633	ASSY TUBE FUEL	1	<=50497			0.025	0.055
160	32751-42630	ASSY TUBE FUEL	1	>=50498	—		0.045	0.099
170	09661-40400	TUBE FUEL	1	<=50497			0.02	0.044
170	09661-40500	TUBE FUEL	1	>=50498	—		0.03	0.066
180	14971-42750	CLIP PIPE	2				0.001	0.0022

FUEL FILTER [COMPONENT PARTS]

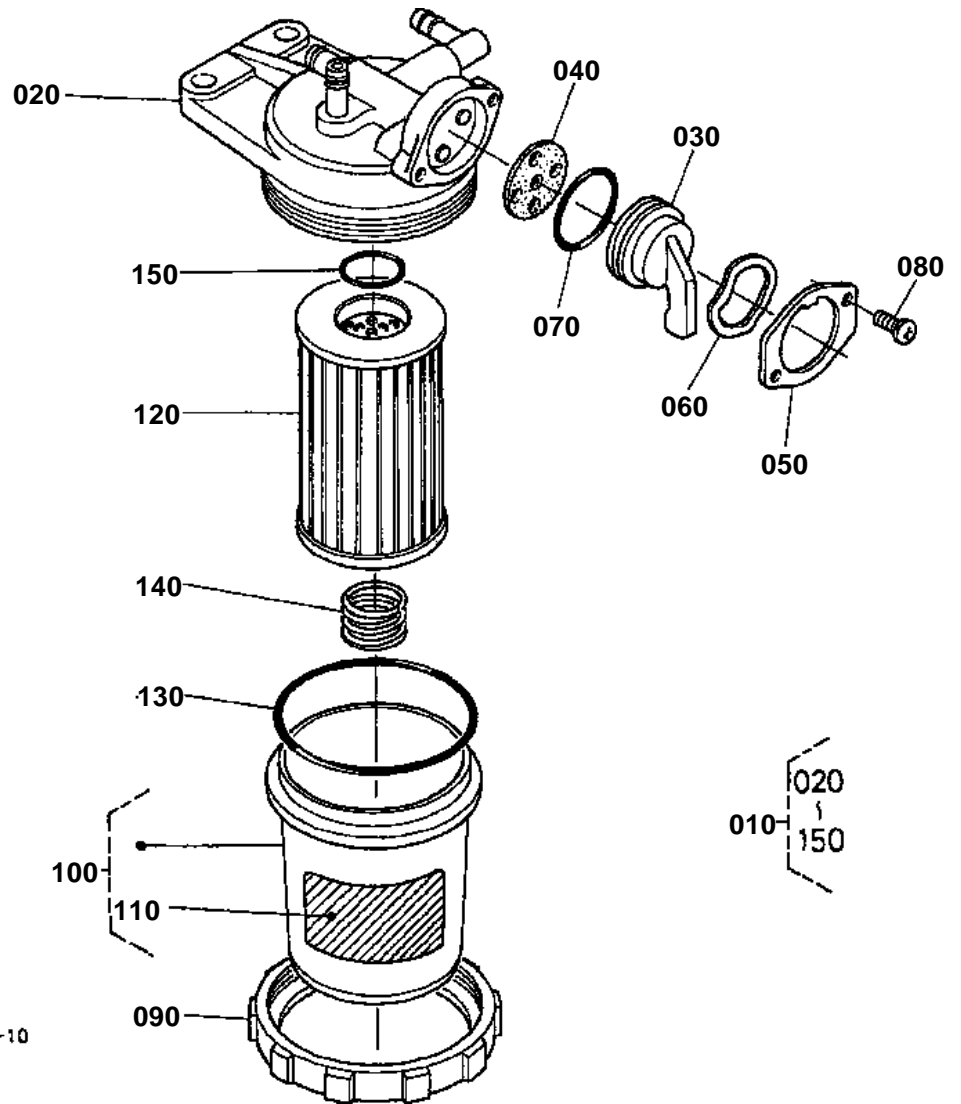

32430-014-10

**FUEL FILTER [COMPONENT PARTS]**

↔ Interchangeable; ≠ not interchangeable; ← new for old; → old for new

REF.No	Part No.	Description	Q'ty	S.No.	I/C	REMARKS	Weight (kgf)	Weight (lb)
010	19271-43010	ASSY FILTER FUEL	1				0	0
010	15521-43015	ASSY FILTER FUEL	1		«		0.59	1.298
020	15521-43112	ASSY BODY	1				0	0
020	15521-43114	ASSY BODY	1		«		0.235	0.517
030	15521-43522	HANDLE FILTER	1				0.04	0.088
040	15521-43672	GASKET	1				0.001	0.0022
050	15521-43552	RETAINER HANDLE	1				0.01	0.022
060	15521-43542	PLATE THRUST	1				0.001	0.0022
070	04811-10290	O RING	1				0.001	0.0022
080	03054-50308	SCREW WITH WASHER	2				0.005	0.011
090	15521-43150	RING RETAINER	1				0.14	0.308
100	19271-43100	ASSY POT FILTER	1				0	0
100	15521-43100	ASSY POT FILTER	1		«		0.05	0.11
110	19271-87210	LABEL CAUTION	1				0.001	0.0022
110	16873-88430	LABEL CAUTION	1		«		0.001	0.0022
120	15521-43160	ELEMENT FILTER	1				0	0
130	04811-50650	O RING	1				0.002	0.0044
140	15521-43930	SPRING	1				0.004	0.0088
150	04811-00160	O RING	1				0	0
150	04816-00160	O RING	1		«		0.003	0.0066

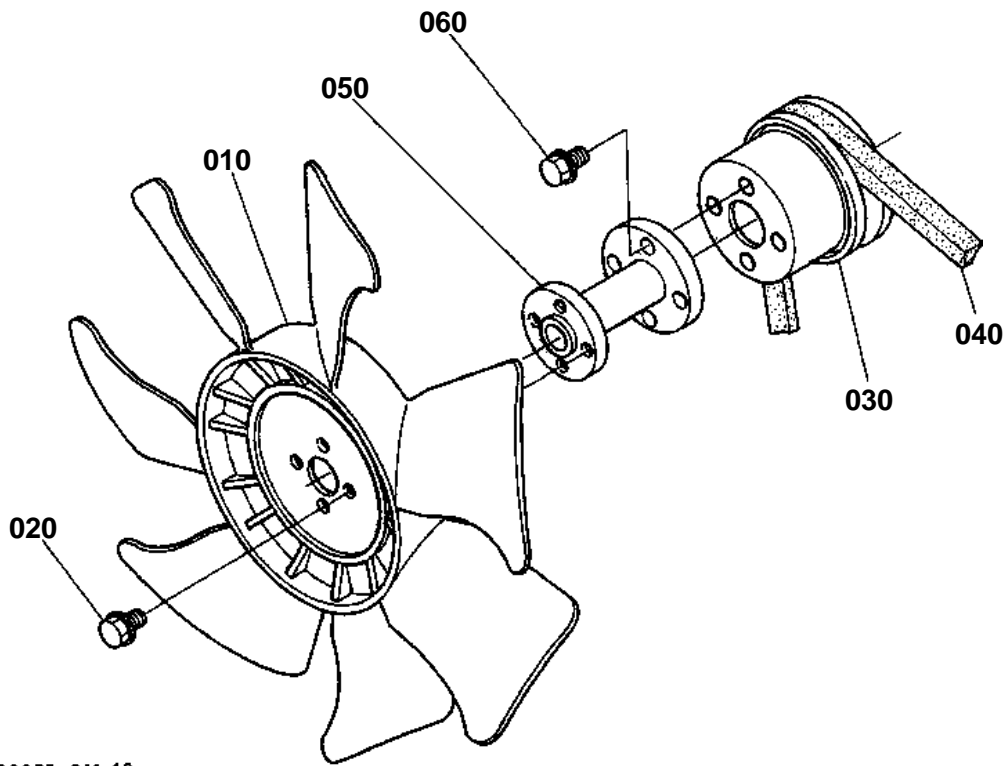

T0070-011-10

**FAN**

↔ Interchangeable; ≠ not interchangeable; ← new for old; → old for new

REF.No	Part No.	Description	Q'ty	S.No.	I/C	REMARKS	Weight (kgf)	Weight (lb)
010	34070-16210	FAN	1				1	2.2
020	01754-50612	BOLT FLANGE	4				0.005	0.011
030	15471-74250	PULLEY FAN	1				0.3	0.66
040	15469-97010	V BELT A	1				0.095	0.209
050	T0070-16220	FLANGE FAN	1	<=60285			0	0
050	T0070-16222	FLANGE FAN	1	>=60286	-		0.195	0.429
060	01754-50620	BOLT FLANGE	4	<=60285			0.007	0.0154
060	01754-50625	BOLT FLANGE	4	>=60286	-		0.008	0.0176

WATER PIPE

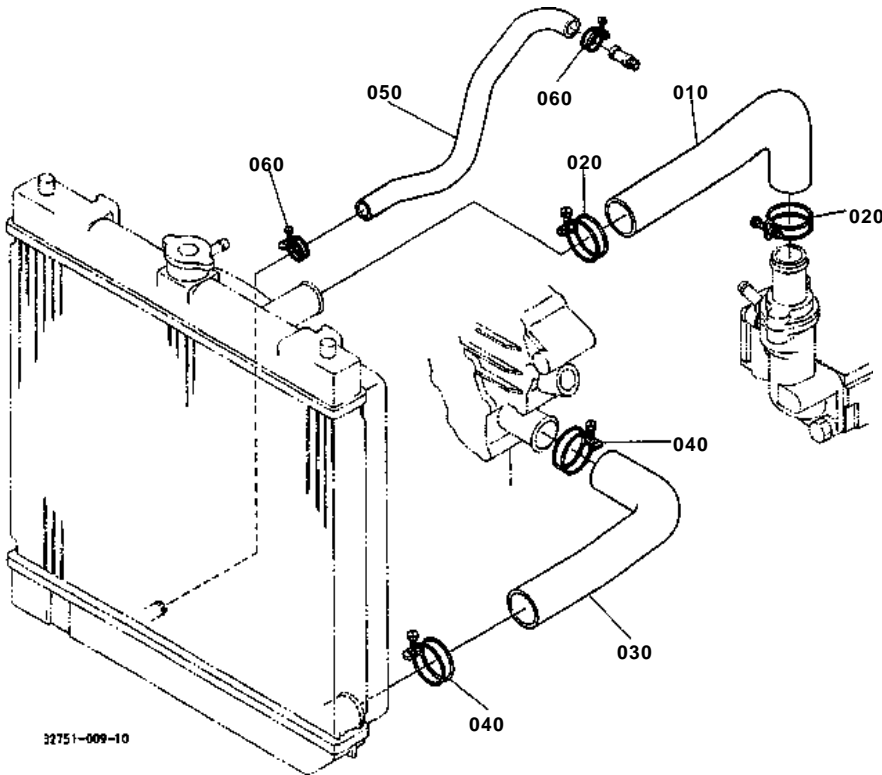



WATER PIPE

↔ Interchangeable; ≠ not interchangeable; ← new for old; → old for new

REF.No	Part No.	Description	Q'ty	S.No.	I/C	REMARKS	Weight (kgf)	Weight (lb)
010	32751-16120	PIPE WATER	1				0.19	0.418
020	15108-72870	BAND	2				0.027	0.0594
030	32751-16140	HOSE WATER LOWER	1				0.19	0.418
040	15108-72870	BAND	2				0.027	0.0594
050	32751-16160	HOSE DRAIN	1				0.084	0.1848
060	68171-63630	BAND HOSE	2				0.013	0.0286

RADIATOR

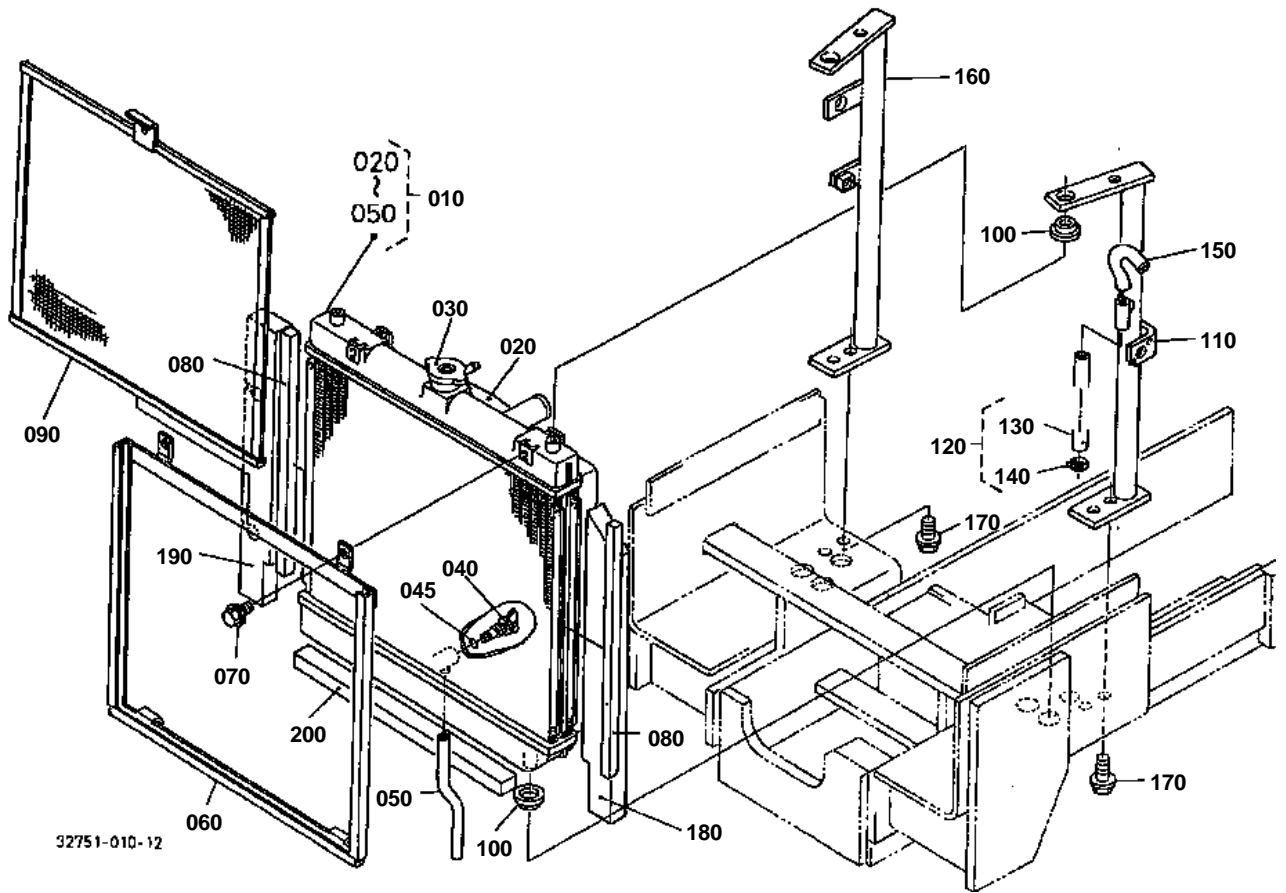

**RADIATOR**

↔ Interchangeable; ≠ not interchangeable; ← new for old; → old for new

REF.No	Part No.	Description	Q'ty	S.No.	I/C	REMARKS	Weight (kgf)	Weight (lb)
010	34070-16000	ASSY RADIATOR	1				5.2	11.44
020	34070-16020	SHROUD FAN	1				1.5	3.3
030	34070-16060	CAP RADIATOR	1				0.055	0.121
040	34070-16070	PLUG DRAIN	1				0.005	0.011
045	34070-16090	O RING	1				0.001	0.0022
050	34070-16080	HOSE DRAIN	1				0.005	0.011
060	32751-16040	GUIDE	1				0.64	1.408
070	01754-50610	BOLT FLANGE	2				0.006	0.0132
080	32751-40660	SPONGE	2				0.009	0.0198
090	32751-16240	NET RADIATOR	1				0.325	0.715
100	34070-16030	RUBBER	4				0.015	0.033
110	32751-16210	SUPPORT RADIATOR LH	1	<=60285			0	0
110	32751-16216	SUPPORT RADIATOR LH	1	>=60286	↔		1.27	2.794
120	32751-16254	ASSY HOSE BREATHER	1			NOT SALE	0	0
130	09663-80650	TUBE FUEL	1				0.075	0.165
140	09318-88115	CLAMP HOSE	1				0.002	0.0044
150	31351-37140	BREATHER	1				0.01	0.022
160	32751-16220	SUPPORT RADIATOR RH	1	<=60285			0	0
160	32751-16226	SUPPORT RADIATOR RH	1	>=60286	↔		1.27	2.794
170	01774-51016	BOLT FLANGE	4				0.02	0.044
180	32751-41170	SPONGE	1				0.021	0.0462
190	32751-41180	SPONGE	1				0.02	0.044
200	32751-41190	SPONGE	1				0.018	0.0396

RESERVE TANK

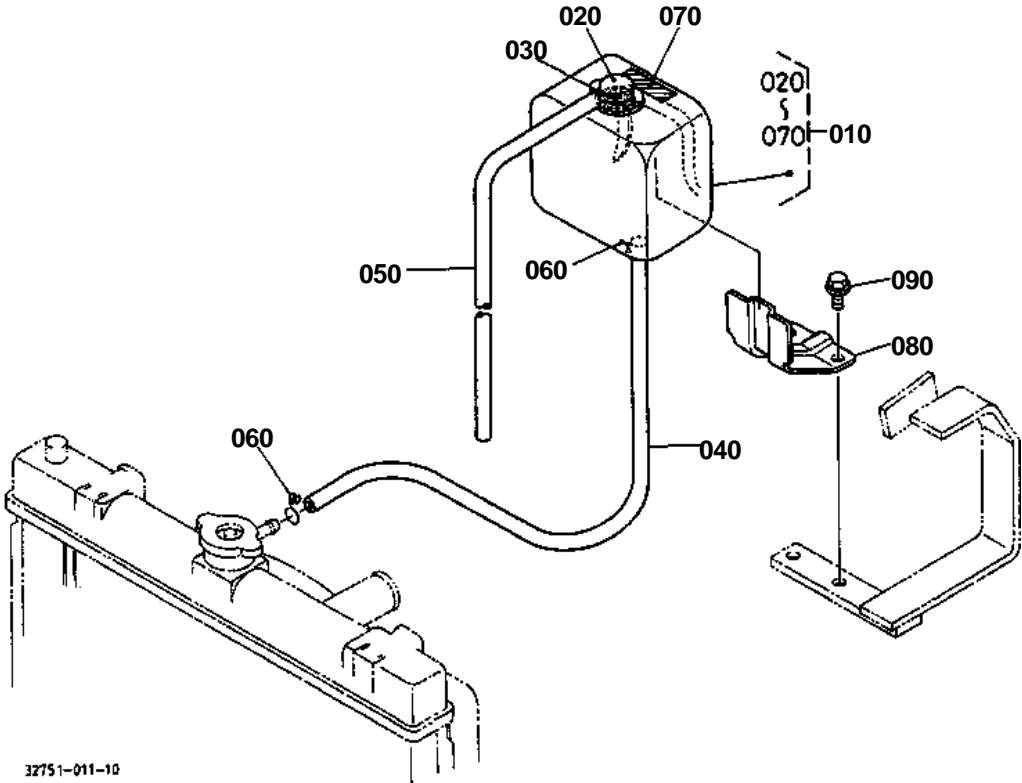



RESERVE TANK

↔ Interchangeable; ≠ not interchangeable; ← new for old; → old for new

REF.No	Part No.	Description	Q'ty	S.No.	I/C	REMARKS	Weight (kgf)	Weight (lb)
010	68841-42360	TANK RESERVE	1				0.48	1.056
020	15272-72420	CAP	1				0.03	0.066
030	15272-72430	GASKET	1				0	0
030	15531-72432	GASKET	1		«		0.002	0.0044
040	17325-72440	PIPE WATER OVERFLOW	1				0.065	0.143
050	68111-42390	PIPE WATER OVERFLOW	1				0.04	0.088
060	15501-72470	CLIP PIPE	2				0.005	0.011
070	15501-88210	LABEL CAUTION	1				0.005	0.011
080	T0070-16710	STAY RESERVE TANK	1				0.09	0.198
090	01754-50816	BOLT FLANGE	2				0.011	0.0242

ALTERNATOR

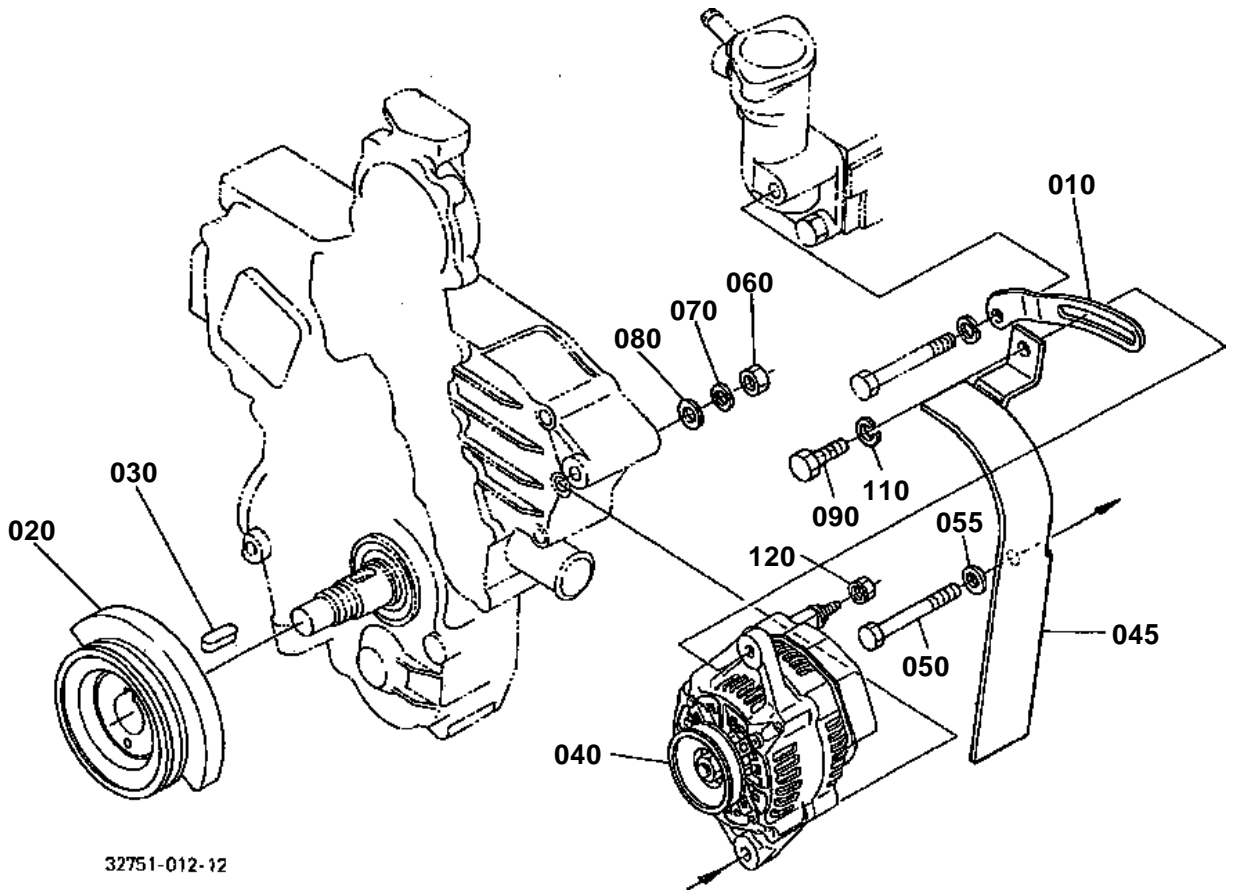

045 32751-1386-0
100 04015-60080

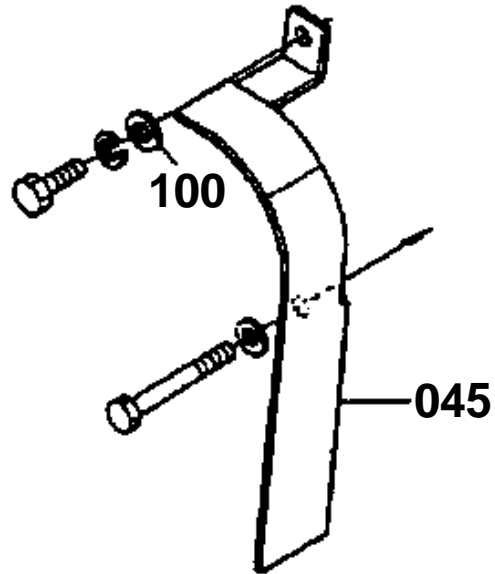

120 02056-50060
130 04512-60060

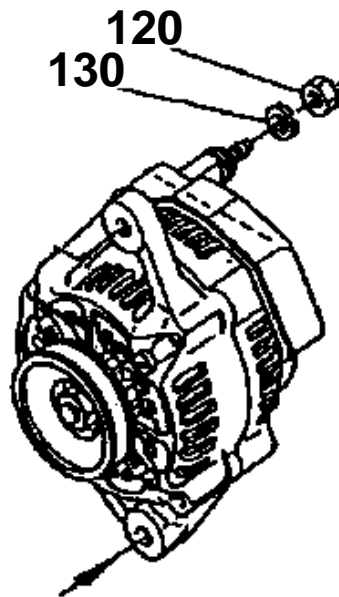

32751-812-11



ALTERNATOR

↔ Interchangeable; ≠ not interchangeable; ← new for old; → old for new

REF.No	Part No.	Description	Q'ty	S.No.	I/C	REMARKS	Weight (kgf)	Weight (lb)
010	16427-64420	STAY DYNAMO	1				0.08	0.176
020	16427-74280	PULLEY FAN DRIVE	1	<=61182			0	0
020	16427-74282	PULLEY FAN DRIVE	1	>=61183	↔		1.39	3.058
030	05712-00720	KEY FEATHER	1				0.008	0.0176
040	34070-75600	ASSY ALTERNATOR	1	<=72348			0	0
040	34070-75602	ASSY ALTERNATOR	1	>=72349	↔		2.85	6.27
045	32751-13860	COVER FAN BELT	1	<=60722			0.021	0.0462
045	3A011-97350	KIT COVER FAN BELT	1	>=60723	↔	WITH LABEL	1.35	2.97
050	01173-51002	BOLT	1				0.065	0.143
055	04015-60100	WASHER PLAIN	1				0.015	0.033
060	02156-50100	NUT	1				0.005	0.011
070	04512-60100	WASHER SPRING	1				0.002	0.0044
080	04011-50100	WASHER PLAIN	1				0.002	0.0044
090	01153-60830	BOLT	1				0.01	0.022
100	04015-60080	WASHER PLAIN	1	<=60722			0.01	0.022
110	04512-60080	WASHER SPRING	1				0.002	0.0044
120	02056-50060	NUT	1	<=72642			0.002	0.0044
120	12264-92020	NUT	1	>=72643	↔		0.05	0.11
130	04512-60060	WASHER SPRING	1	<=72642			0.001	0.0022

ALTERNATOR [COMPONENT PARTS]

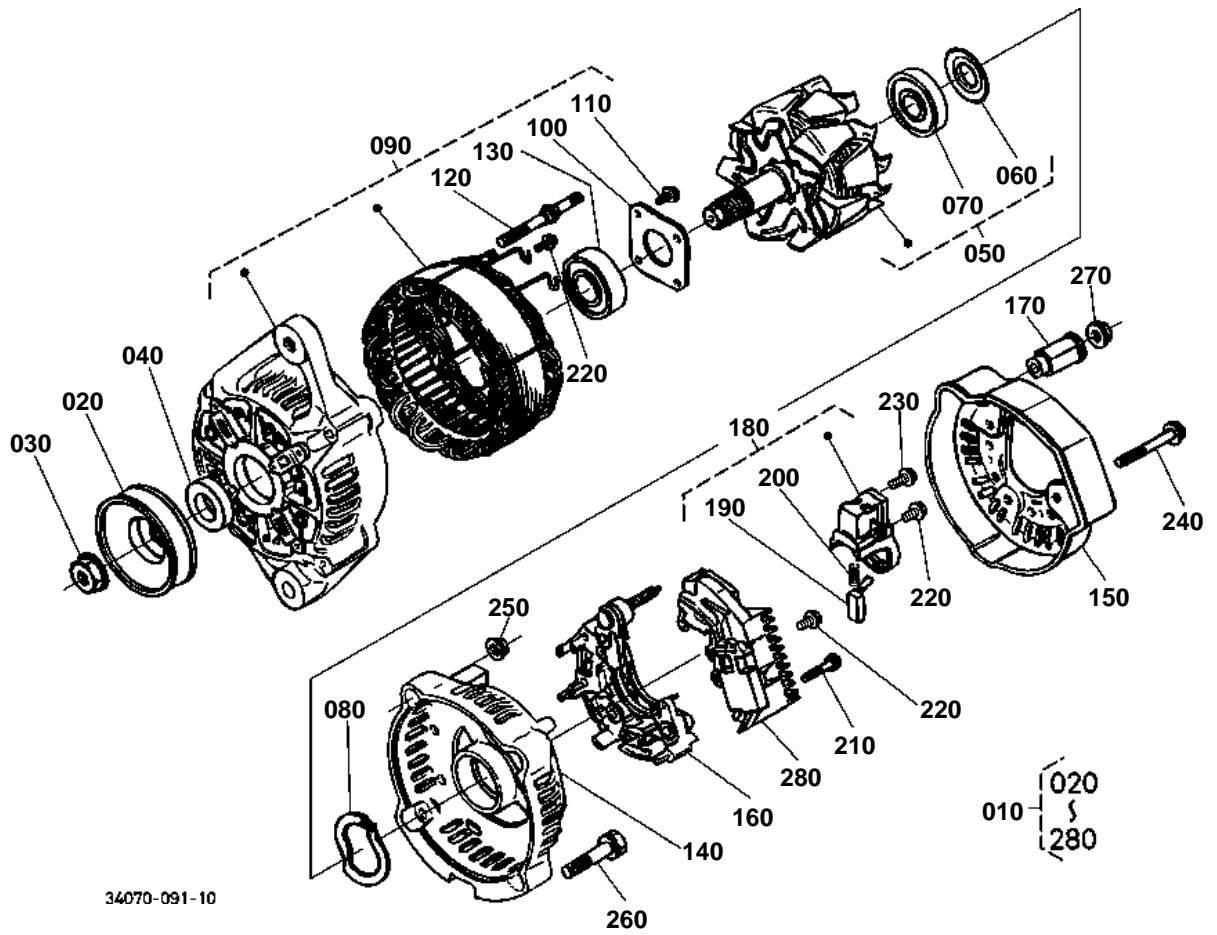



ALTERNATOR [COMPONENT PARTS]

↔ Interchangeable; ≠ not interchangeable; ← new for old; → old for new

REF.No	Part No.	Description	Q'ty	S.No.	I/C	REMARKS	Weight (kgf)	Weight (lb)
010	34070-75600	ASSY ALTERNATOR	1	<=72348			0	0
010	34070-75602	ASSY ALTERNATOR	1	>=72349	→		2.85	6.27
020	16427-64110	PULLEY ALTERNATOR	1				0.2	0.44
030	15881-92010	NUT	1				0.02	0.044
040	15881-64150	COLLAR	1				0.004	0.0088
050	15881-64040	ROTOR	1	<=72348		NOT SALE	0	0
050	66436-64040	ROTOR	1	>=72349	→		1.2	2.64
060	15881-64800	COVER BEARING	1				0.001	0.0022
070	15881-64770	BEARING BALL	1	<=72348			0.04	0.088
070	16652-64770	BEARING BALL	1	>=72349	1		0.045	0.099
080	15881-64810	WASHER THRUST	1				0.002	0.0044
090	15881-64020	FRAME DRIVE END	1	<=72348			1.2	2.64
090	66436-64020	ASSY FRAME DRIVE END	1	>=72349	1		1.11	2.442
100	15881-64710	PLATE RETAINER	1				0.01	0.022
110	15881-93010	SCREW ROUND HEAD	4				0.003	0.0066
120	15881-64260	BOLT THROUGH	2				0.01	0.022
130	15881-64780	BEARING BALL	1	<=72348			0.05	0.11
130	16652-64780	BEARING BALL	1	>=72349	1		0.05	0.11
140	16241-64060	FRAME END	1				0.2	0.44
150	16241-64230	COVER END	1	<=72438			0	0
150	16231-64230	COVER END	1	>=72439	1		0.035	0.077
160	16241-64850	ASSY RECTIFIER	1				0	0
170	16241-64900	BUSH INSULATION	1				0.007	0.0154
180	15881-64310	HOLDER BRUSH	1	<=72438			0.025	0.055
180	16652-64310	HOLDER BRUSH	1	>=72439	1		0.025	0.055
190	15881-64090	BRUSH	2				0.002	0.0044
200	15881-64330	SPRING BRUSH	2				0.002	0.0044
210	15881-93020	SCREW ROUND HEAD	2				0.005	0.011
220	15881-93030	SCREW ROUND HEAD	6				0.003	0.0066
230	15881-93040	SCREW ROUND HEAD	1				0.003	0.0066
240	15881-91040	BOLT	3				0.005	0.011
250	15881-92020	NUT	2				0.02	0.044
260	15881-91050	BOLT	2				0.01	0.022
270	14182-92030	NUT	1				0.003	0.0066
280	66436-64600	ASSY REGULATOR	1				0	0

STARTER

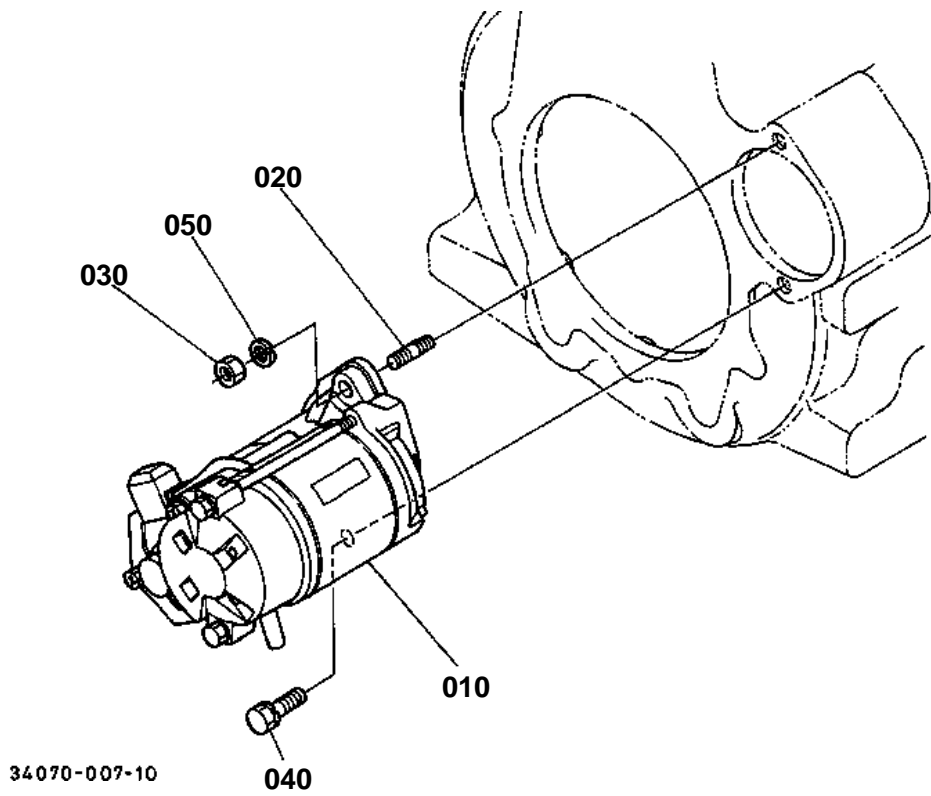



STARTER

↔ Interchangeable; ≠ not interchangeable; ← new for old; → old for new

REF.No	Part No.	Description	Q'ty	S.No.	I/C	REMARKS	Weight (kgf)	Weight (lb)
010	34070-16800	ASSY STARTER	1				3.4	7.48
020	01517-51028	STUD	1				0.022	0.0484
030	02176-50100	NUT	1				0.005	0.011
040	01133-51030	BOLT	1				0.025	0.055
050	04512-50100	WASHER SPRING	1				0	0

STARTER [COMPONENT PARTS]

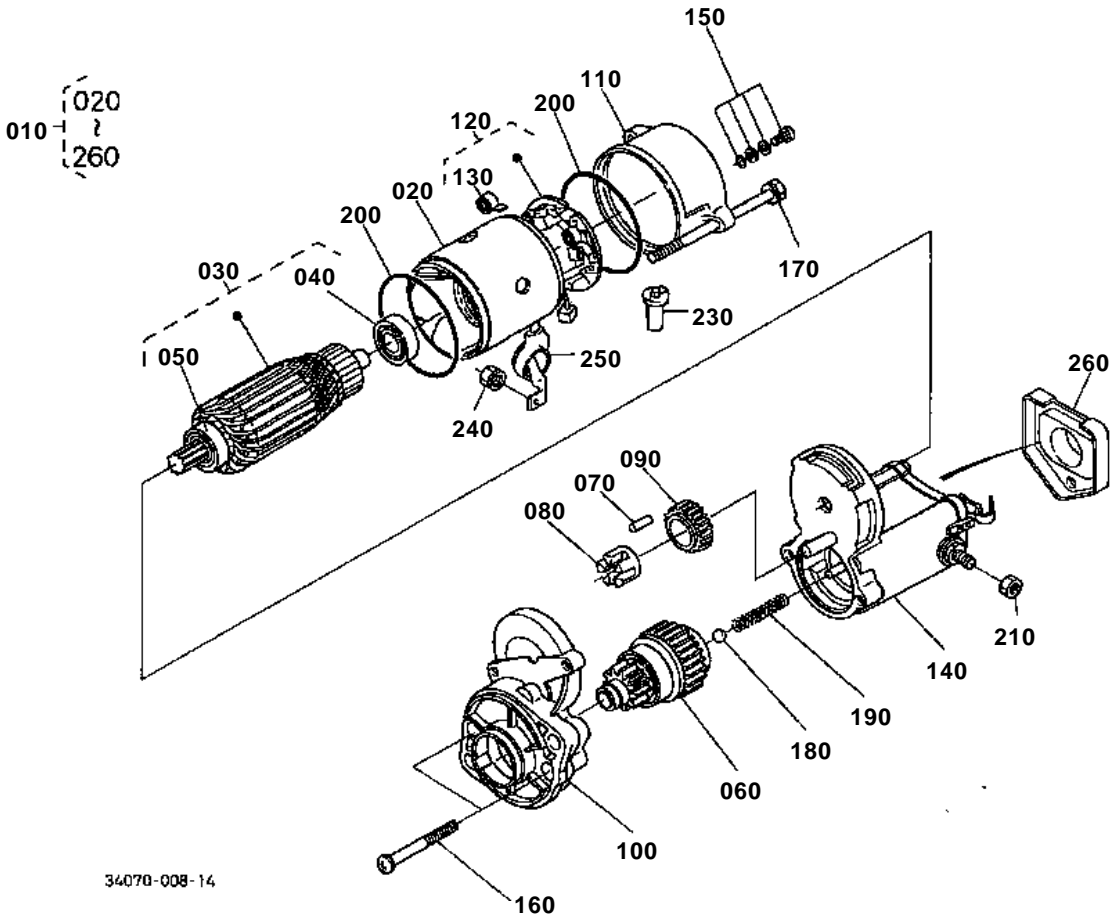

**STARTER [COMPONENT PARTS]**

↔ Interchangeable; ≠ not interchangeable; ← new for old; → old for new

REF.No	Part No.	Description	Q'ty	S.No.	I/C	REMARKS	Weight (kgf)	Weight (lb)
010	34070-16800	ASSY STARTER	1				3.4	7.48
020	11460-63080	YOKE	1				0.8	1.76
030	11460-63070	ARMATURE	1				0.05	0.11
040	11460-63530	BEARING	1				0.02	0.044
050	11460-63500	BEARING	1				0.03	0.066
060	34070-16810	ASSY CLUTCH	1				0.565	1.243
070	19212-63100	ROLLER	5				0.002	0.0044
080	11460-63110	RETAINER	1				0.01	0.022
090	11460-63270	GEAR	1				0.04	0.088
100	34070-16830	ASSY HOUSING	1				0.405	0.891
110	34070-16840	ASSY FRAME END	1				0.1	0.22
120	11470-63380	ASSY HOLDER BRUSH	1				0.3	0.66
130	11460-63390	SPRING BRUSH	4				0.01	0.022
140	34070-16850	ASSY SWITCH MAGNETO	1				0.955	2.101
150	15511-63760	ASSY BOLT	2				0.005	0.011
160	11460-93310	BOLT	2				0.01	0.022
170	11460-63320	BOLT THROUGH	2				0.02	0.044
180	19212-97130	BALL	1				0.003	0.0066
190	11460-63120	SPRING	1				0.01	0.022
200	15511-96660	O RING	2				0.005	0.011
210	13963-92010	NUT HEXAGON	1				0.005	0.011
220	99999-99999	BLANK	0				0	0
230	16285-63570	PIPE DRAIN	1				0.005	0.011
240	16285-92010	NUT HEXAGON	1				0.005	0.011
250	11173-63130	COVER TERMINAL	1				0.007	0.0154
260	16285-98050	ASSY COVER	1				0.048	0.1056

BATTERY

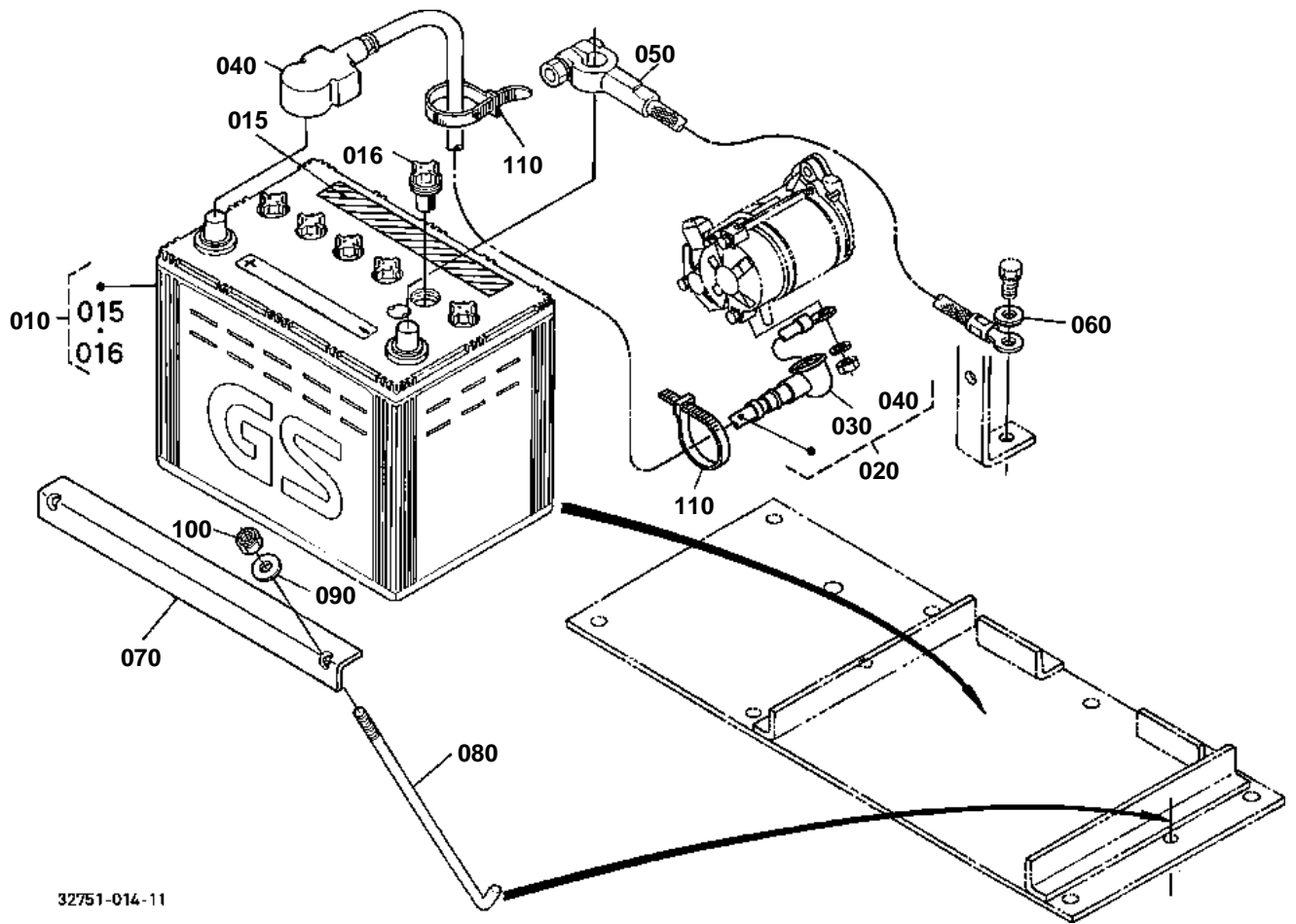

32751-014-11

**BATTERY**

↔ Interchangeable; ≠ not interchangeable; ← new for old; → old for new

REF.No	Part No.	Description	Q'ty	S.No.	I/C	REMARKS	Weight (kgf)	Weight (lb)
010	99999-99999	BATTERY	1				0	0
015	TA040-30150	LABEL BATTERY	1			ENGLISH	0.002	0.0044
016	TA040-30160	CAP BATTERY	6				0.01	0.022
020	T0070-30122	CORD BATTERY	1				0	0
020	TA240-30120	CORD BATTERY	1		«		0.485	1.067
030	T0070-30130	CAP	1				0.015	0.033
040	T0070-30140	CAP	1				0.012	0.0264
050	32751-30380	CORD EARTH	1	<=50801			0	0
050	34200-33380	CORD EARTH	1	>=50802	«		0.19	0.418
060	04015-60100	WASHER PLAIN	1				0.015	0.033
070	32701-54480	RETAINER BATTERY	1				0.2	0.44
080	38240-33295	BOLT HOOK	2				0.05	0.11
090	04015-60060	WASHER PLAIN	2				0.005	0.011
100	76611-56730	NUT LOCK	2				0.005	0.011
100	02552-50060	NUT LOCK	2		«		0.002	0.0044
110	55311-41260	BAND CORD	2				0.007	0.0154

SWITCH

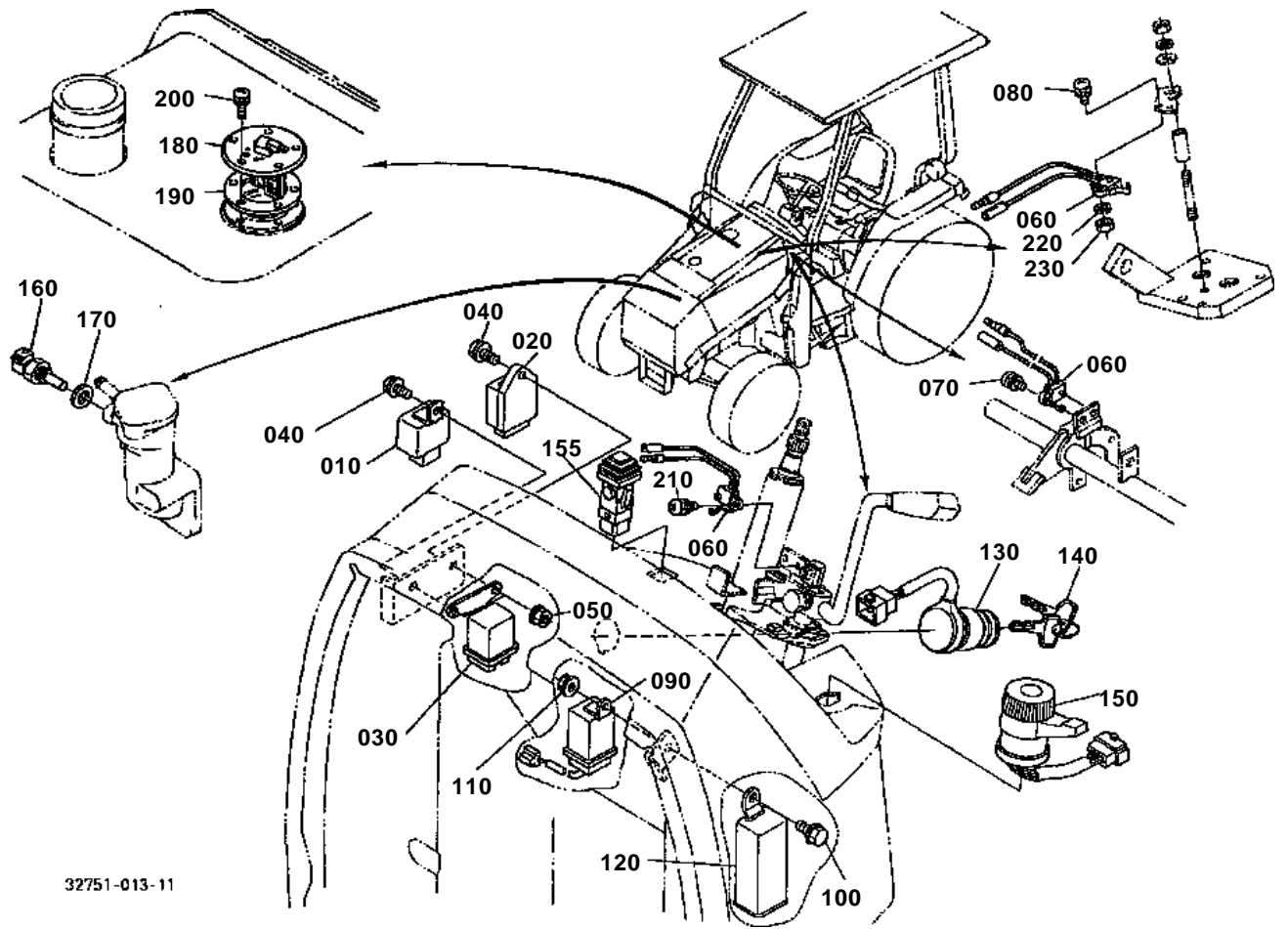

32751-013-11

080 03054-50416

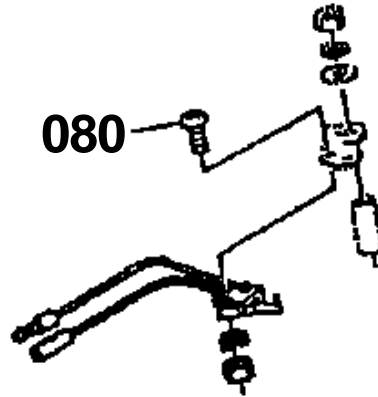

120 32400-3370-0

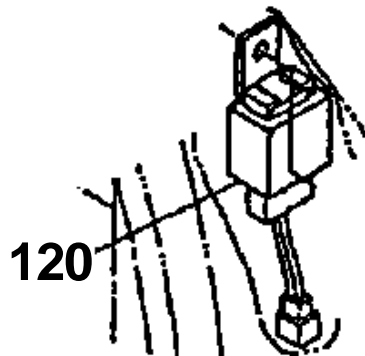

32751-819-10

**SWITCH**

↔ Interchangeable; ≠ not interchangeable; ← new for old; → old for new

REF.No	Part No.	Description	Q'ty	S.No.	I/C	REMARKS	Weight (kgf)	Weight (lb)
010	T0070-31410	TIMER KEY STOP	1				0.065	0.143
020	16415-65660	CONTROLLER	1				0.07	0.154
030	16415-65600	RELAY GLOW	1				0.1	0.22
040	01754-50620	BOLT FLANGE	2				0.007	0.0154
050	02751-50060	NUT FLANGE	2				0.005	0.011
060	TA040-43900	SWITCH LEVER	3				0.008	0.0176
070	03024-50414	SCREW WITH WASHER	2				0.002	0.0044
080	03054-50416	SCREW CR-REC-PAN-HD	1	<=60382			0.002	0.0044
080	03024-50425	SCREW WITH WASHER	1	>=60383	→		0.003	0.0066
090	35800-75070	RELAY STARTER	1				0.08	0.176
100	01754-50610	BOLT FLANGE	1				0.006	0.0132
110	02751-50060	NUT FLANGE	1				0.005	0.011
120	32400-33700	HAZARD UNIT	1	<=72556			0.07	0.154
120	3F240-75430	UNIT FLASHER	1	>=72557	↑		0.06	0.132
130	34670-31820	SWITCH MAIN	1	<=70270			0	0
130	34670-31822	SWITCH MAIN	1	>=70271	→		0	0
130	34670-31823	SWITCH MAIN	1	>=73431	→		0.026	0.0572
140	35260-31852	ASSYKEY MAIN SWITCH	1				0.03	0.066
150	TA040-30850	SWITCH COMBINATION	1	<=72556			0.11	0.242
150	3A751-75010	SWITCH COMBINATION	1	>=72557	↑		0.115	0.253
153	35999-12660	NUT RING	1				0.015	0.033
155	TA140-30910	SWITCH HAZARD	1	>=72557			0.115	0.253
160	16415-83040	SENSOR THERMO	1				0.03	0.066
170	15109-33660	GASKET	1				0.001	0.0022
180	34070-31200	ASSY GAUGE FUEL	1	<=50835			0	0
180	TA040-31200	ASSY GAUGE FUEL	1	>=50836	→		0	0
180	TA040-31202	ASSY GAUGE FUEL	1	>=60286	→		0.505	1.111
190	34070-31220	GASKET	1				0.01	0.022
200	03024-50512	SCREW WITH WASHER	5				0.003	0.0066
210	03024-50425	SCREW WITH WASHER	1				0.003	0.0066
220	04512-50040	WASHER SPRING	1				0	0
230	02054-50040	NUT	1				0.001	0.0022

PANEL BOARD

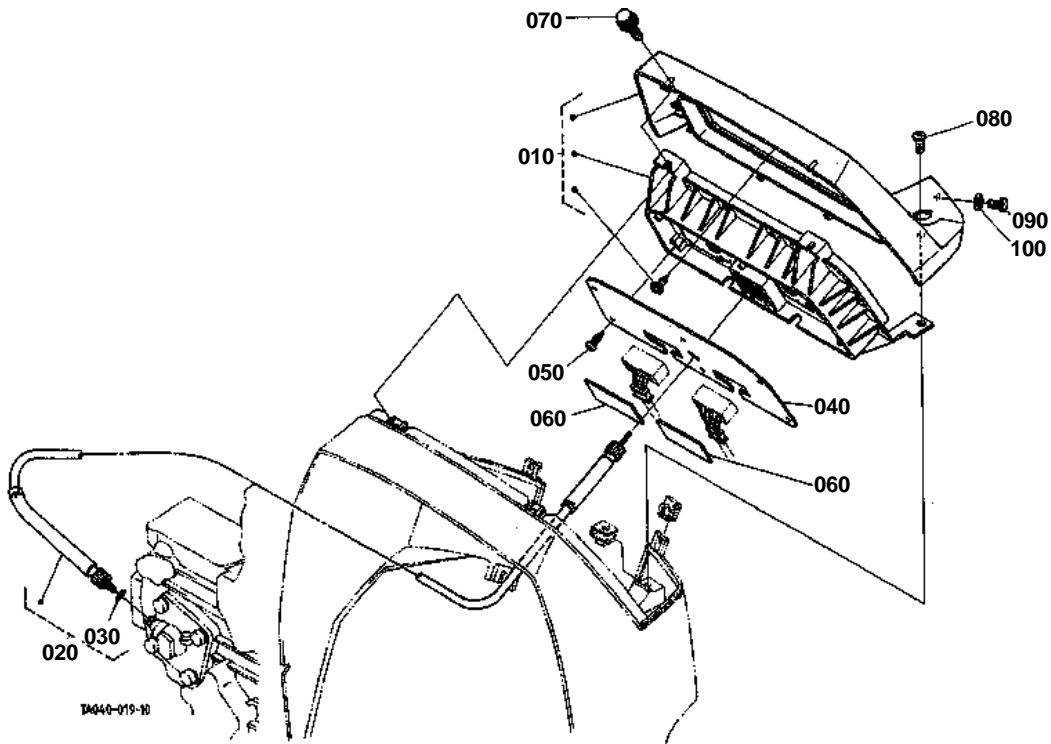



PANEL BOARD

↔ Interchangeable; ≠ not interchangeable; ← new for old; → old for new

REF.No	Part No.	Description	Q'ty	S.No.	I/C	REMARKS	Weight (kgf)	Weight (lb)
010	TA040-30210	ASSY PANEL	1	<=72556			1.75	3.85
010	TA140-30210	ASSY PANEL	1	>=72557	1		1.72	3.784
020	38240-34655	CABLE ELEXIBLE	1				0.22	0.484
030	04811-10080	O RING	1				0.001	0.0022
040	34070-30190	PLATE PANEL	1				0.15	0.33
050	03514-50414	SCREW TAPPING	6				0.001	0.0022
060	34070-99410	SEAL PANEL	2	<=72318			0	0
060	34070-99412	SEAL PANEL	2	>=72319	1		0.005	0.011
070	34070-41110	BOLT SET	2				0.01	0.022
080	31391-31140	SCREW	2				0.01	0.022
090	37410-54990	SCREW	2				0.003	0.0066
100	04013-60040	WASHER PLAIN	2				0.002	0.0044

PANEL BOARD [COMPONENT PARTS]

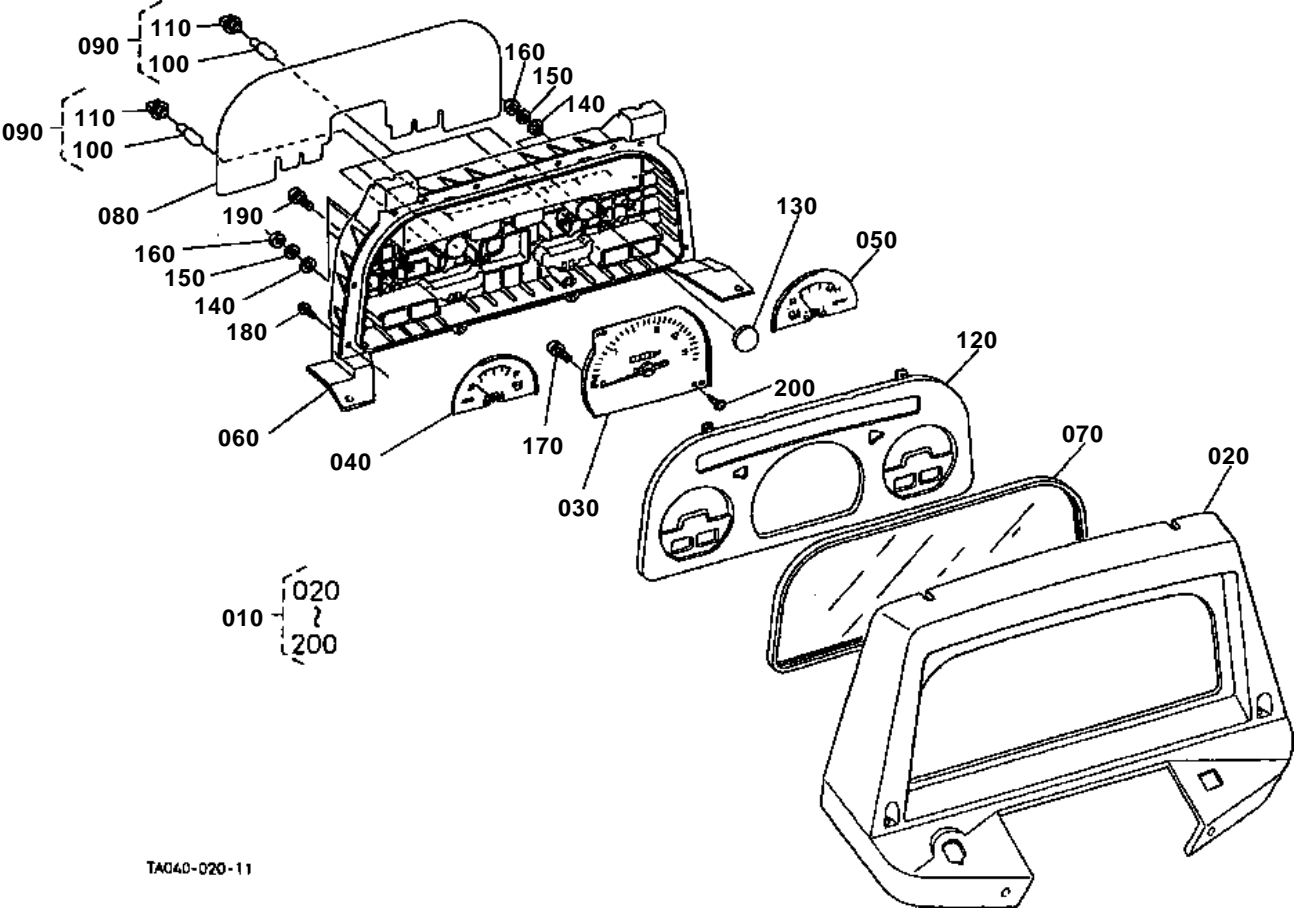

020 TA040-4302-0

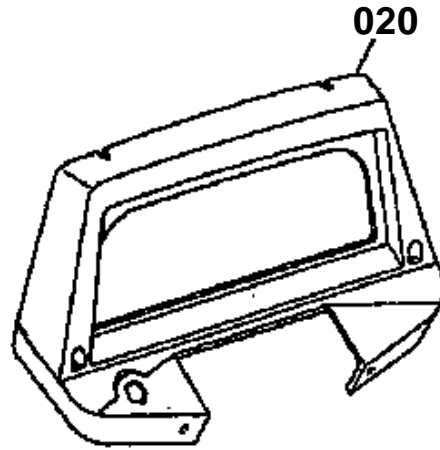

32751-820-10

**PANEL BOARD [COMPONENT PARTS]**

↔ Interchangeable; ≠ not interchangeable; ← new for old; → old for new

REF.No	Part No.	Description	Q'ty	S.No.	I/C	REMARKS	Weight (kgf)	Weight (lb)
010	TA040-30210	ASSY PANEL	1	<=72556			1.75	3.85
010	TA140-30210	ASSY PANEL	1	>=72557	1		1.72	3.784
020	TA040-43020	HOOD PANEL	1	<=72556			0.975	2.145
020	TA040-76620	HOOD PANEL	1	>=72557	1		0.5	1.1
030	TA040-30220	ASSY TACHOMETER	1				0.22	0.484
040	TA040-30230	ASSY METER FUEL	1				0.08	0.176
050	TA040-30240	ASSY THERMOMETER	1				0.08	0.176
060	TA040-30250	CASE	1	<=72556			0.855	1.881
060	TA140-30250	CASE	1	>=72557	1		0.846	1.8612
070	34070-30260	GLASS	1				0.485	1.067
080	TA040-30270	ASSY PLATE	1				0.135	0.297
090	38240-31460	ASSY BULB	9				0.015	0.033
100	38240-31470	BULB	9				0.01	0.022
110	38240-31480	SOCKET	9				0.001	0.0022
120	34070-30280	PLATE WINDOW	1				0.21	0.462
130	34070-30170	LENS	2				0.005	0.011
140	66426-81100	WASHER PLAIN	5				0.001	0.0022
150	04512-50040	WASHER SPRING	5				0	0
160	02054-50040	NUT	5				0.001	0.0022
170	32530-94900	SCREW WITH WASHER	2				0.002	0.0044
180	03514-50425	SCREW TAPPING	10				0.001	0.0022
190	35533-76230	SCREW WITH WASHER	1				0.002	0.0044
200	34070-30290	SCREW TAPPING	2				0.01	0.022

LIGHT [OLD TYPE]

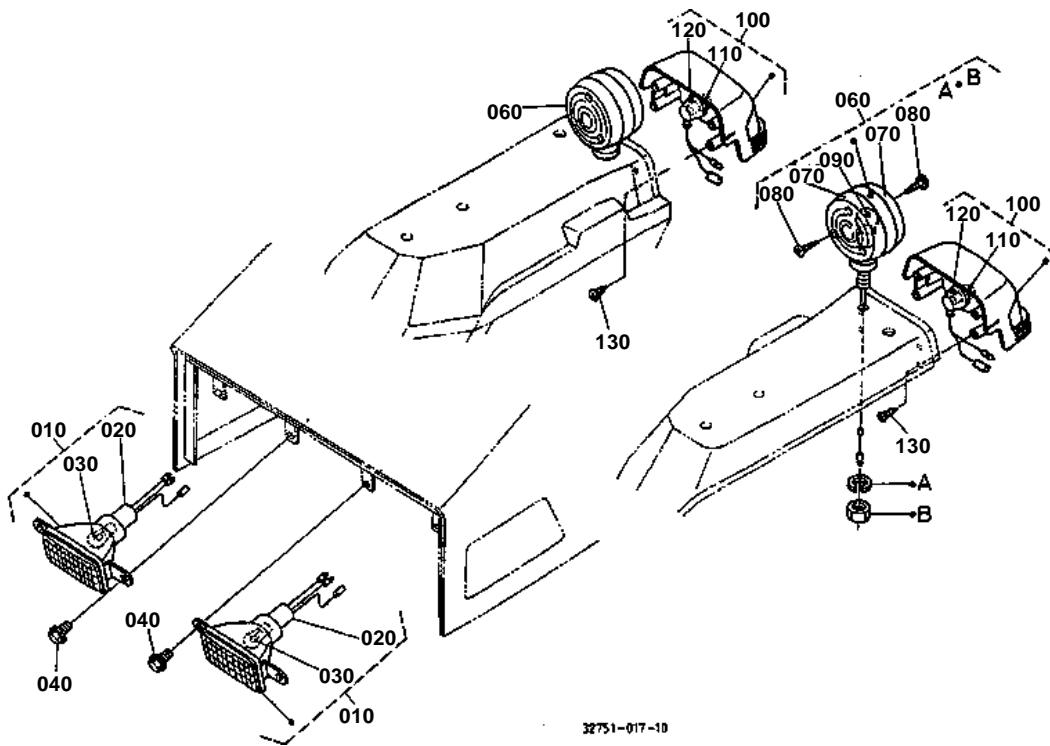

**LIGHT [OLD TYPE]**

S.No.;<=72556

↔ Interchangeable; ≠ not interchangeable; ← new for old; → old for new

REF.No	Part No.	Description	Q'ty	S.No.	I/C	REMARKS	Weight (kgf)	Weight (lb)
010	67111-55700	ASSY LIGHT HEAD	2				0.21	0.462
020	67111-55780	SOCKET HEAD LIGHT	2				0.03	0.066
030	67111-55790	BULB HEAD LIGHT	2			25W	0.01	0.022
040	01754-50612	BOLT FLANGE	4				0.005	0.011
050	99999-99999	BLANK	0				0	0
060	32530-33610	ASSY LIGHT HAZARD	2				0.38	0.836
070	32530-91510	LENS HAZARD LIGHT	4				0.085	0.187
080	32530-91520	SCREW TAPPING	12				0.001	0.0022
090	32530-91530	BULB LIGHT	2			27W	0.02	0.044
100	TA040-30020	LIGHT TAIL	2				0	0
110	TA040-99110	BULB LIGHT	2			8W	0.01	0.022
120	TA040-99120	CORD	2				0.03	0.066
130	03614-50614	SCREW TAPPING	8				0.005	0.011

LIGHT [NEW TYPE]

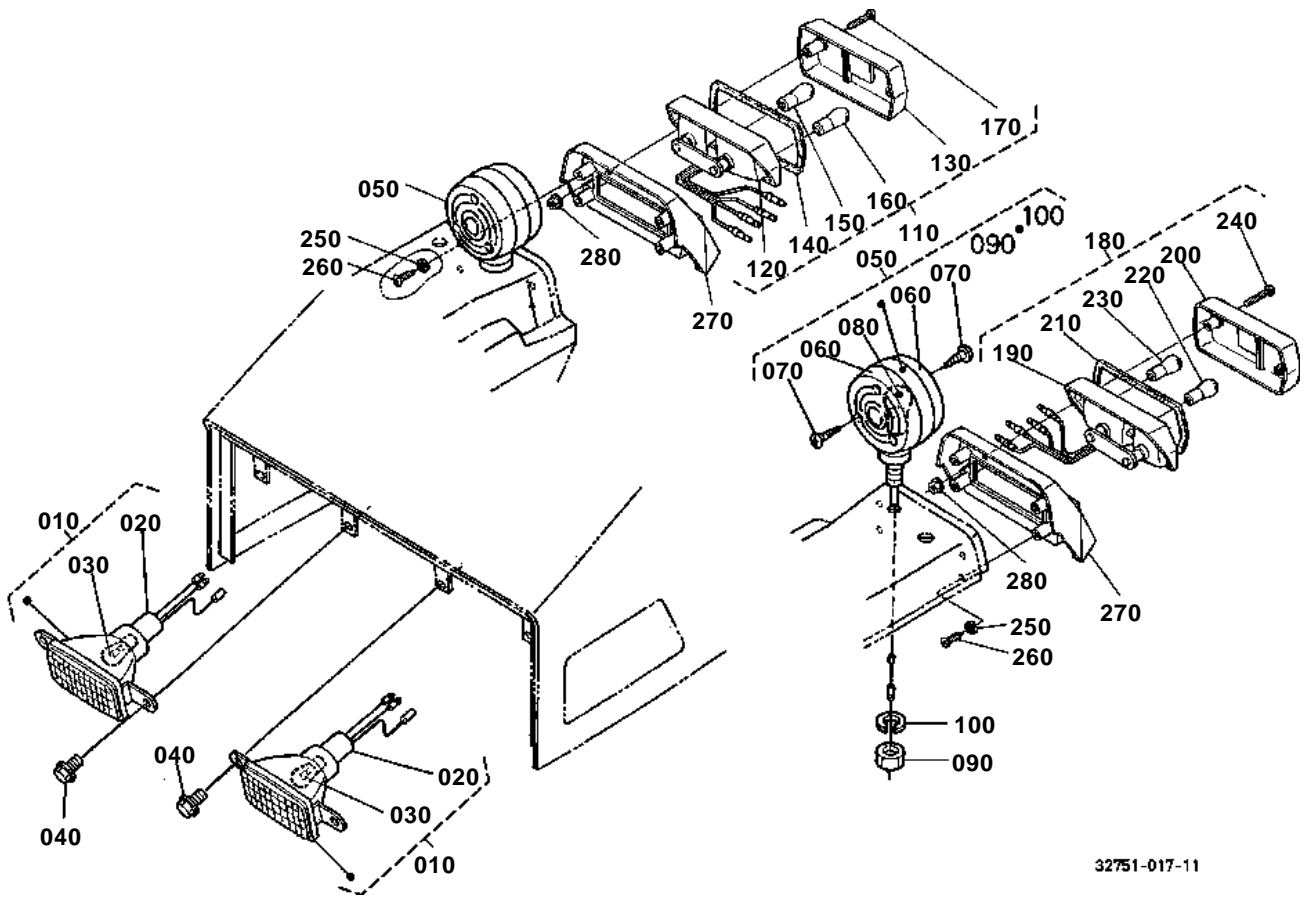

32751-017-11

**LIGHT [NEW TYPE]**

S.No.;>=72557

↔ Interchangeable; ≠ not interchangeable; ← new for old; → old for new

REF.No	Part No.	Description	Q'ty	S.No.	I/C	REMARKS	Weight (kgf)	Weight (lb)
010	67111-55700	ASSY LIGHT HEAD	2				0.21	0.462
020	67111-55780	SOCKET HEAD LIGHT	2				0.03	0.066
030	67111-55790	BULB HEAD LIGHT	2			25W	0.01	0.022
040	01754-50612	BOLT FLANGE	4				0.005	0.011
050	32530-33610	ASSY LIGHT HAZARD	2				0.38	0.836
060	32530-91510	LENS HAZARD LIGHT	4				0.085	0.187
070	32530-91520	SCREW TAPPING	12				0.001	0.0022
080	32530-91530	BULB LIGHT	2			27W	0.02	0.044
090	02114-50100	NUT	2				0.005	0.011
100	04411-50100	WASHER TOOTHED	2				0.001	0.0022
110	31301-34303	ASSY LIGHT COMBI.RH	1				0.4	0.88
120	31301-34320	BODY RH	1				0.18	0.396
130	31301-34340	LENS	1				0.105	0.231
140	31391-34350	GASKET	1				0.002	0.0044
150	31391-34360	BULB	1			12V23W	0.018	0.0396
160	31301-34370	BULB	1			12V23/8W	0.02	0.044
170	31391-34380	SCREW	2	<=73536			0	0
170	T1150-34380	SCREW	2	>=73537	-		0.006	0.0132
180	31301-34313	ASSY LIGHT COMBI.LH	1				0.32	0.704
190	31301-34330	BODY LH	1				0.21	0.462
200	31301-34340	LENS	1				0.105	0.231
210	31391-34350	GASKET	1				0.002	0.0044
220	31391-34360	BULB	1			12V23W	0.018	0.0396
230	31301-34370	BULB	1			12V23/8W	0.02	0.044
240	31391-34380	SCREW	2	<=73536			0	0
240	T1150-34380	SCREW	2	>=73537	-		0.006	0.0132
250	04512-60060	WASHER SPRING	8				0.001	0.0022
260	03614-50614	SCREW TAPPING	8				0.005	0.011
270	34040-68960	HOLDER	2				0.23	0.506
280	02761-50050	NUT FLANGE	4				0.002	0.0044

ELECTRICAL WIRING [OLD TYPE]

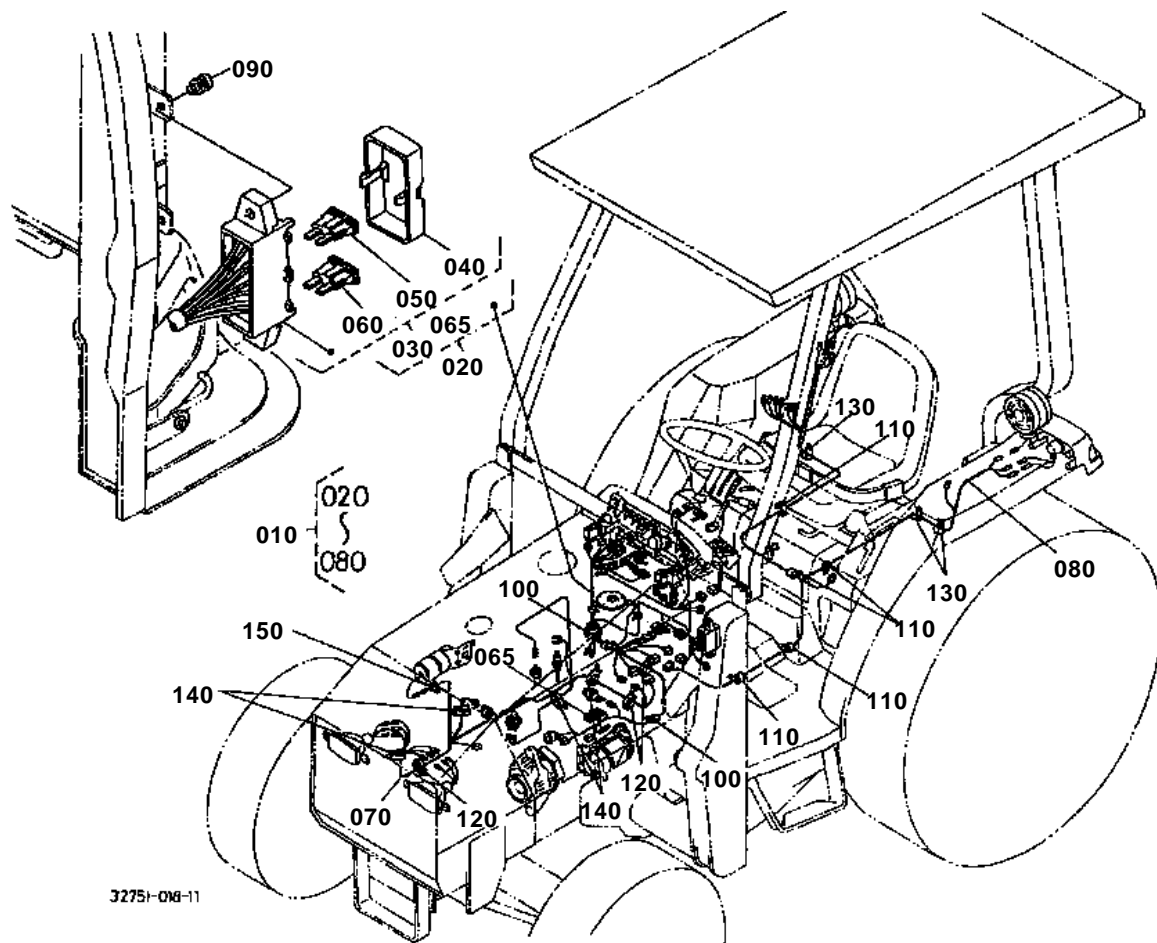

**ELECTRICAL WIRING [OLD TYPE]**

S.No.;<=72556

↔ Interchangeable; ≠ not interchangeable; ← new for old; → old for new

REF.No	Part No.	Description	Q'ty	S.No.	I/C	REMARKS	Weight (kgf)	Weight (lb)
010	32751-30300	ASSY WIRE HARNESS	1				1.6	3.52
020	32751-30310	WIRE HARNESS	1				0.965	2.123
030	32751-30400	ASSY BOX FUSE	1				0.1	0.22
040	32751-30410	COVER FUSE BOX	1				0	0
040	TA040-30410	COVER FUSE BOX	1		«		0.03	0.066
050	36730-75550	FUSE	6			10A	0.001	0.0022
060	35820-75560	FUSE	3			15A	0.002	0.0044
065	34670-34530	FUSE	1			40A	0.003	0.0066
070	32751-30320	WIRE HARNESS	1				0.27	0.594
080	32751-30330	WIRE HARNESS	1				0.32	0.704
090	03024-50512	SCREW WITH WASHER	2				0.003	0.0066
100	34260-29380	CLAMP CORD	2				0	0
100	35340-29380	CLAMP CORD	2		«		0.01	0.022
110	35340-29380	CLAMP CORD	5				0.01	0.022
120	55311-41260	BAND CORD	3				0.007	0.0154
130	37150-34460	CLAMP CORD	3				0.004	0.0088
140	53581-64150	BAND CORD	4				0.002	0.0044
150	15241-67580	CLAMP CORD	1				0.004	0.0088

ELECTRICAL WIRING [NEW TYPE]

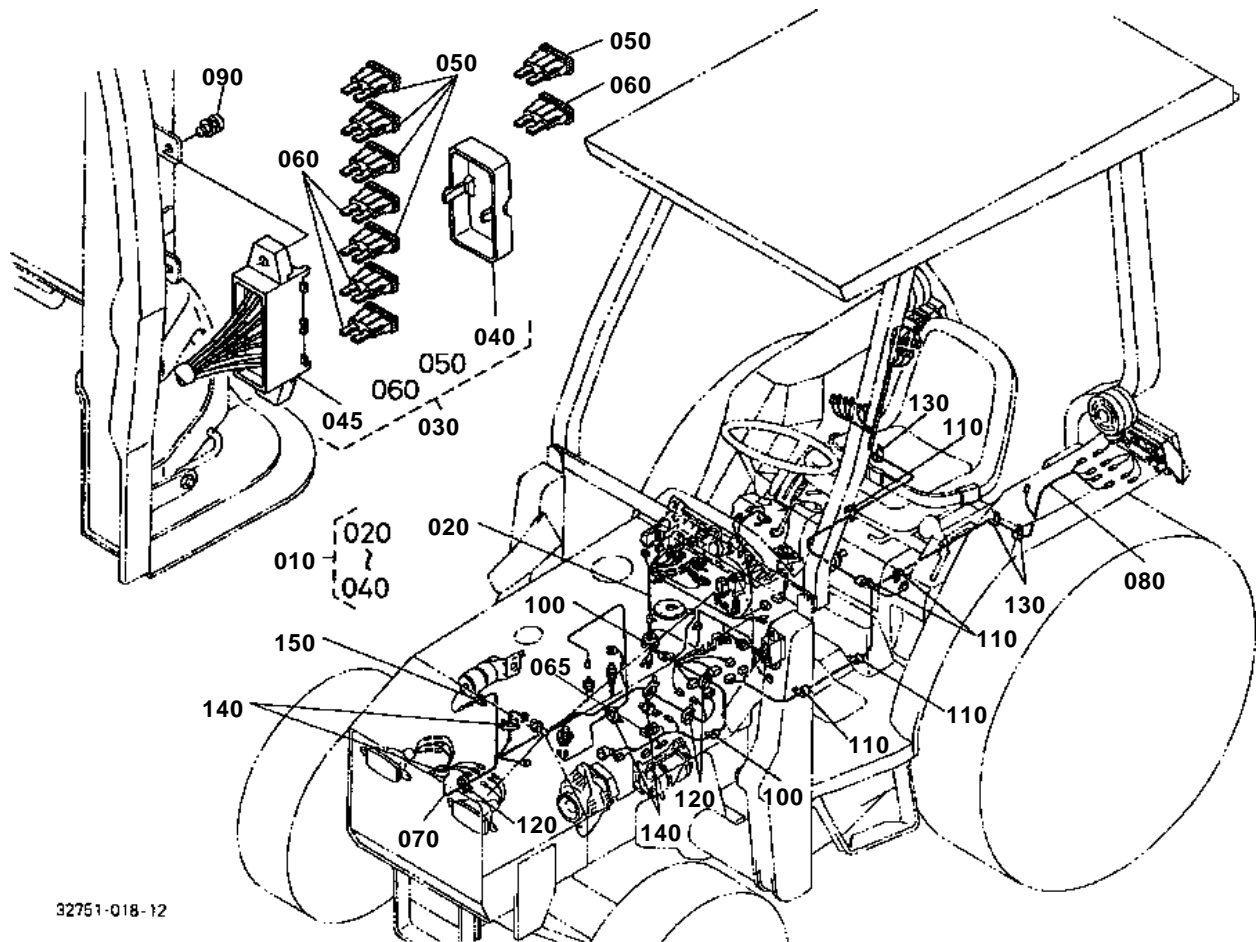

**ELECTRICAL WIRING [NEW TYPE]**

S.No.;>=72557

↔ Interchangeable; ≠ not interchangeable; ← new for old; → old for new

REF.No	Part No.	Description	Q'ty	S.No.	I/C	REMARKS	Weight (kgf)	Weight (lb)
010	32751-30500	ASSY WIRE HARNESS	1	<=72642		NOT SALE	0	0
010	32751-30502	ASSY WIRE HARNESS	1	>=72643	-	NOT SALE	0	0
020	32751-30510	WIRE HARNESS	1	<=72642			0	0
020	32751-30512	WIRE HARNESS	1	>=72643	-		1.13	2.486
030	32751-30402	ASSY BOX FUSE	1				0.1	0.22
040	32751-30610	COVER FUSE BOX	1				0	0
045	35533-77350	ASSY CASE FUSE	1				0.04	0.088
050	36730-75550	FUSE	5			10A	0.001	0.0022
060	35820-75560	FUSE	4			15A	0.002	0.0044
065	34670-34530	FUSE	1			40A	0.003	0.0066
070	32751-30320	WIRE HARNESS	1				0.27	0.594
080	32751-30530	WIRE HARNESS	1				0.37	0.814
090	03024-50512	SCREW WITH WASHER	2				0.003	0.0066
100	34260-29380	CLAMP CORD	2				0	0
100	35340-29380	CLAMP CORD	2			«	0.01	0.022
110	35340-29380	CLAMP CORD	5				0.01	0.022
120	55311-41260	BAND CORD	3				0.007	0.0154
130	37150-34460	CLAMP CORD	3				0.004	0.0088
140	53581-64150	BAND CORD	4				0.002	0.0044
150	15241-67580	CLAMP CORD	1				0.004	0.0088

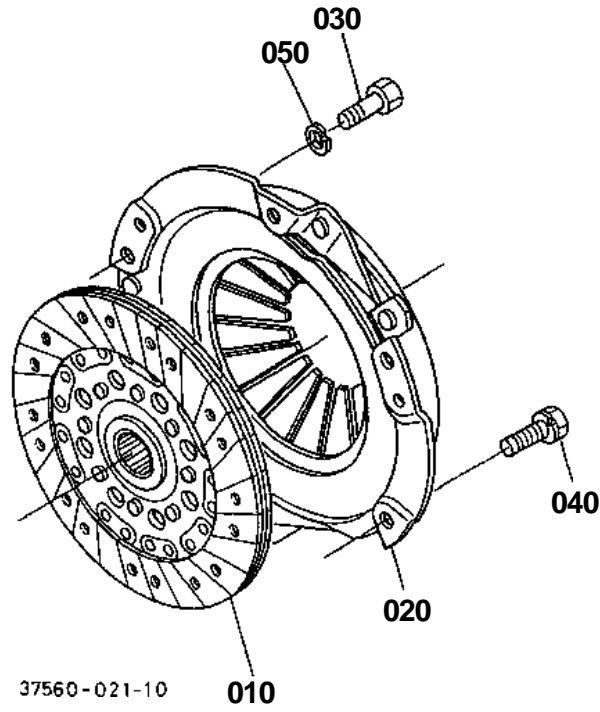



CLUTCH

↔ Interchangeable; ≠ not interchangeable; ← new for old; → old for new

REF.No	Part No.	Description	Q'ty	S.No.	I/C	REMARKS	Weight (kgf)	Weight (lb)
010	32425-14300	COMP.DISK CLUTCH	1				0.96	2.112
020	32430-14500	ASSY PLATE PRESSURE	1				5.3	11.66
030	34220-14510	BOLT REAMER	2				0.013	0.0286
030	T1270-14510	BOLT REAMER	2		<<		0.01	0.022
040	01123-50816	BOLT	7				0	0
050	04512-50080	WASHER SPRING	2				0	0

CLUTCH LEVER

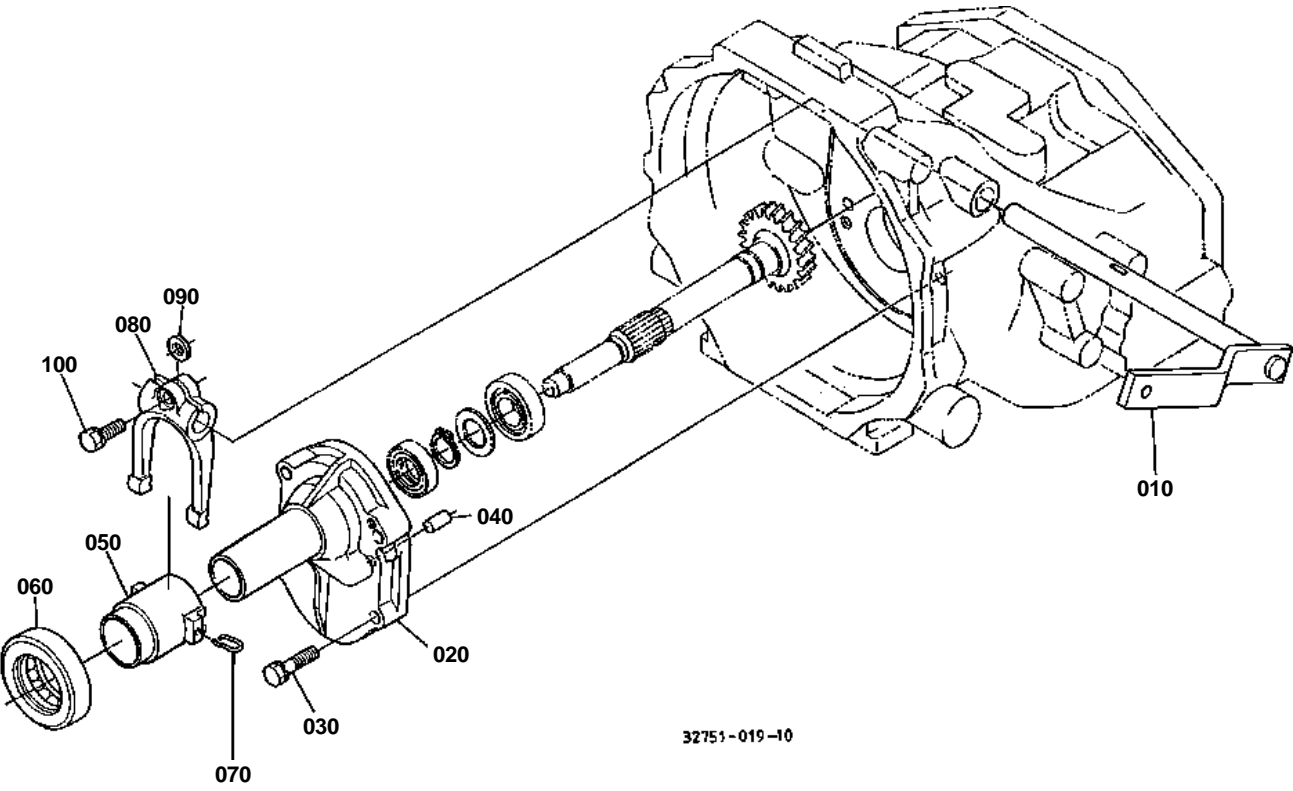



CLUTCH LEVER

↔ Interchangeable; ≠ not interchangeable; ← new for old; → old for new

REF.No	Part No.	Description	Q'ty	S.No.	I/C	REMARKS	Weight (kgf)	Weight (lb)
010	34070-21170	LEVER CLUTCH	1	<=70431			0	0
010	34070-21174	LEVER CLUTCH	1	>=70432	-		0	0
010	T1030-21170	LEVER CLUTCH	1	>=3N0001	-		0.9	1.98
020	32751-21100	CASE PROPELLER SHAFT	1				0.74	1.628
030	01123-50838	BOLT	4				0.02	0.044
040	05012-00818	PIN STRAIGHT	2				0.013	0.0286
050	32751-21150	HOLDER CLUTCH	1				0.365	0.803
060	08490-00001	BEARING THRUST BALL	1				0.227	0.4994
070	34070-21210	PIN SNAP	2				0.005	0.011
070	TA040-21210	PIN SNAP	1		«		0.002	0.0044
080	34070-21200	FORK CLUTCH RELEASE	1				0.375	0.825
090	31150-14780	KEY FORK	1				0.003	0.0066
100	01123-50825	BOLT	1				0.013	0.0286

CLUTCH PEDAL

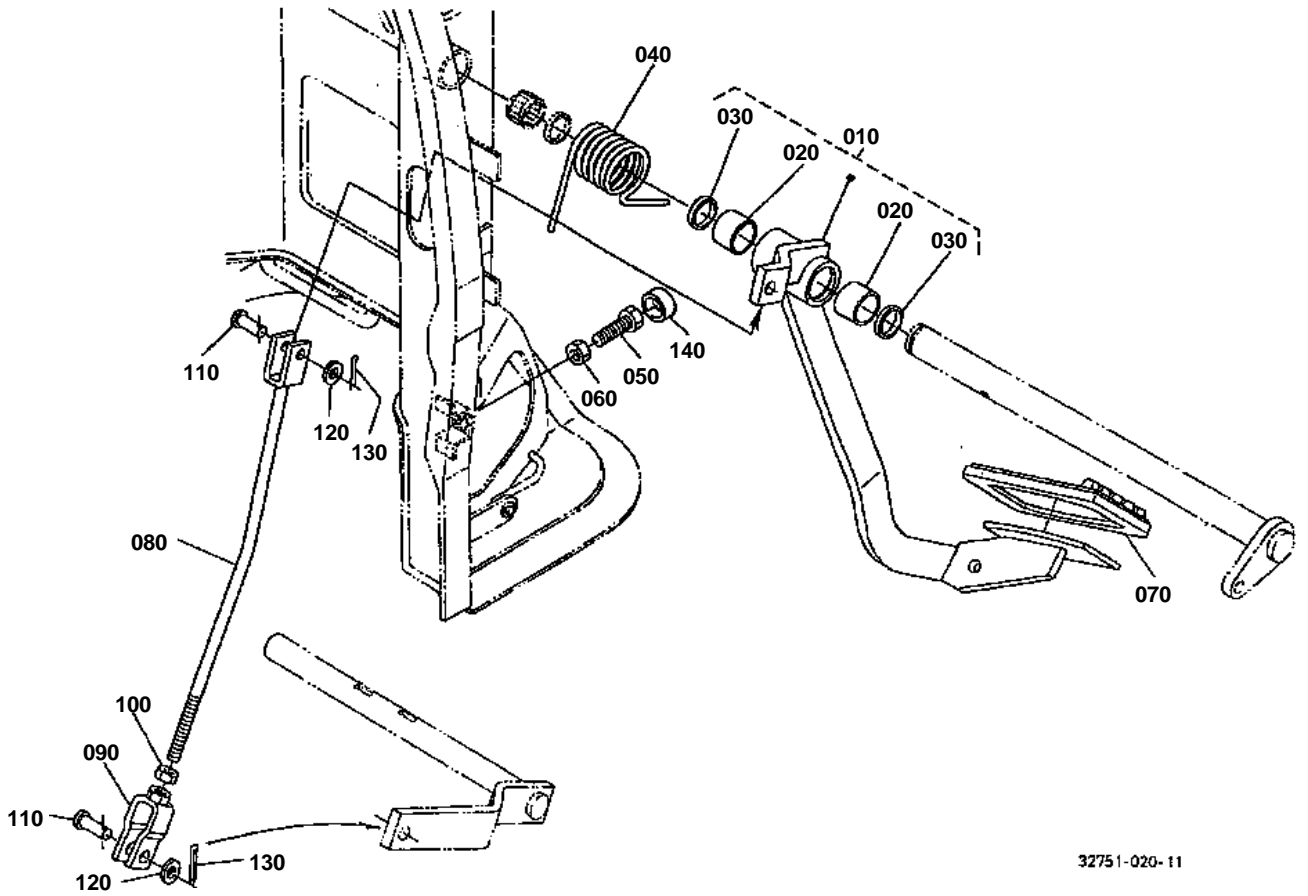

32751-020-11

080 T0070-4446-0

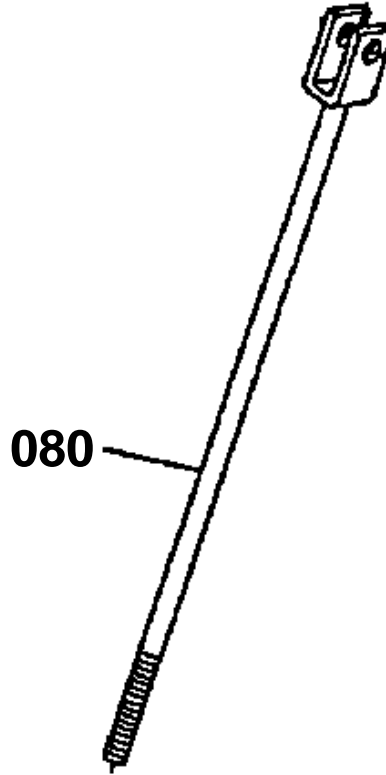

32751-821-10

**CLUTCH PEDAL**

↔ Interchangeable; ≠ not interchangeable; ← new for old; → old for new

REF.No	Part No.	Description	Q'ty	S.No.	I/C	REMARKS	Weight (kgf)	Weight (lb)
010	TA040-44050	COMP.PEDAL CLUTCH	1	<=60084			0	0
010	TA040-44052	COMP.PEDAL CLUTCH	1	>=60085	→		1.6	3.52
020	08511-02520	BUSH	2				0.02	0.044
030	34070-44140	SEAL OIL	2				0.005	0.011
040	TA040-44160	SPRING	1				0.108	0.2376
050	01075-51030	BOLT	1	<=72318			0	0
050	01073-51030	BOLT	1	>=72319	→		0.028	0.0616
060	02116-50100	NUT	1				0.004	0.0088
070	37410-44120	COVER PEDAL	1				0	0
080	T0070-44460	ROD CLUTCH	1				0.115	0.253
080	34070-44460	ROD CLUTCH	1		«		0.225	0.495
090	T0070-44470	U JOINT	1				0.075	0.165
090	34070-44470	U JOINT	1		«		0.08	0.176
100	02156-50080	NUT	1				0.004	0.0088
100	02176-50100	NUT	1		«		0.005	0.011
110	05122-61028	PIN JOINT	2				0.02	0.044
120	04013-50100	WASHER PLAIN	2				0	0
130	05511-50318	PIN SPLIT	2				0.001	0.0022
140	34070-47490	CUSHION	1	<=64245			0.005	0.011
140	T0270-47490	CUSHION	1	>=64246	→		0.002	0.0044

CLUTCH HOUSING

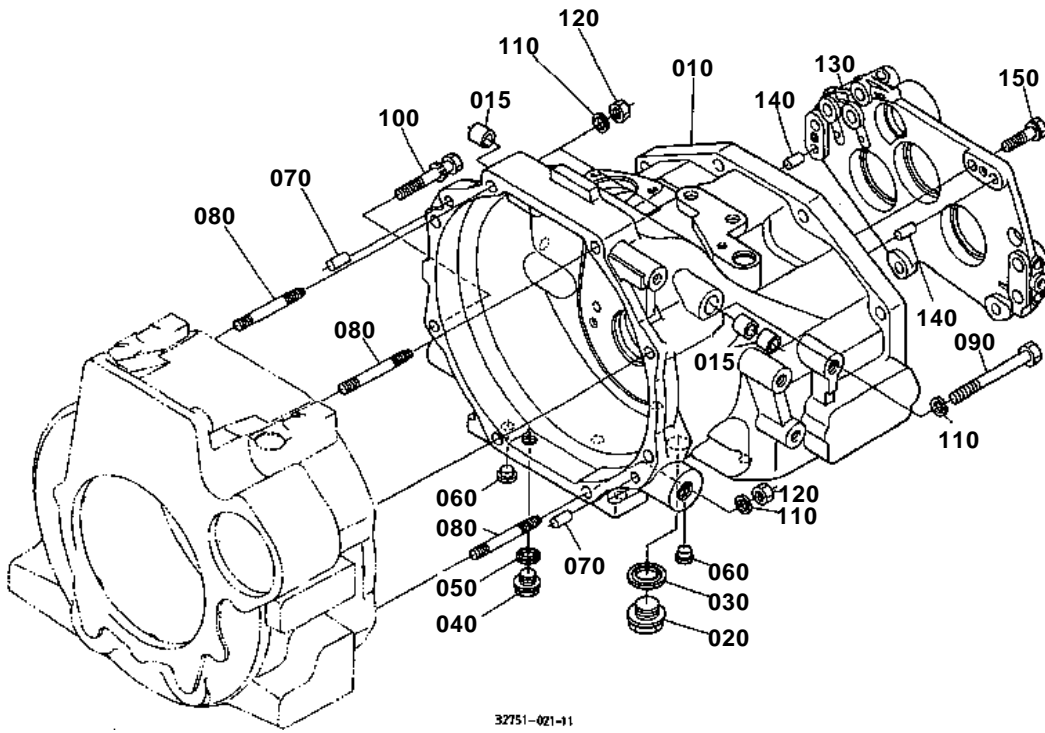

CLUTCH HOUSING

052 06311-25030

053 04717-01700

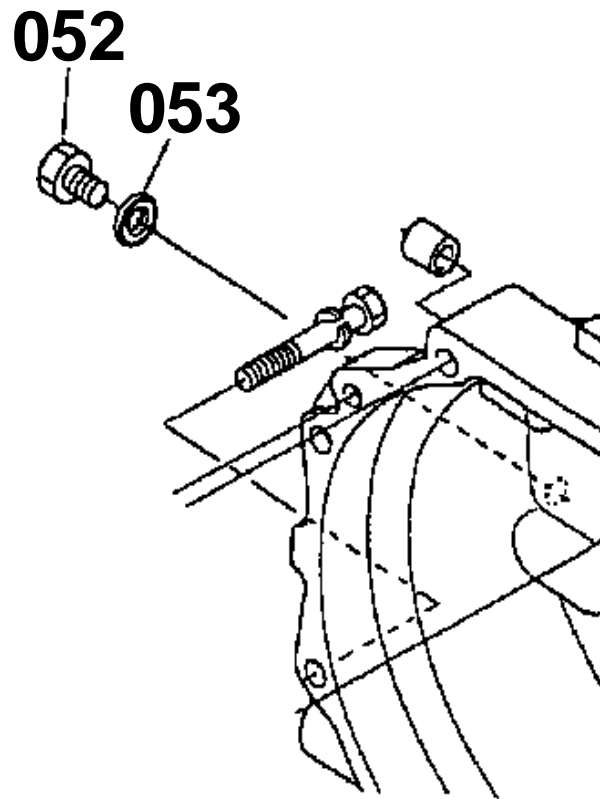

32751-802-10



CLUTCH HOUSING

↔ Interchangeable; ≠ not interchangeable; ← new for old; → old for new

REF.No	Part No.	Description	Q'ty	S.No.	I/C	REMARKS	Weight (kgf)	Weight (lb)
010	32751-20200	HOUSING CLUTCH	1				34	74.8
015	08511-01715	BUSH	3				0.006	0.0132
020	15512-96010	PLUG DRAIN	1				0.101	0.2222
030	04717-02150	WASHER WITH RUBBER	1				0.004	0.0088
040	06311-35020	PLUG	1				0.037	0.0814
050	04717-01400	WASHER WITH RUBBER	1				0.002	0.0044
052	06311-25030	PLUG	1	<=50868			0.051	0.1122
053	04717-01700	WASHER WITH RUBBER	1	<=50868			0.003	0.0066
060	32210-27580	PLUG	12				0.001	0.0022
070	05012-01018	PIN STRAIGHT	2				0.012	0.0264
080	34070-20130	STUD	5				0.045	0.099
090	01173-51001	BOLT	1				0.07	0.154
100	01133-51065	BOLT	2				0.043	0.0946
110	04512-60100	WASHER SPRING	6				0.002	0.0044
120	37300-14190	NUT	5				0.009	0.0198
130	34070-20250	HOLDER BEARING	1				1.025	2.255
140	05012-00818	PIN STRAIGHT	2				0.013	0.0286
150	01133-51035	BOLT	4				0.03	0.066

MID CASE

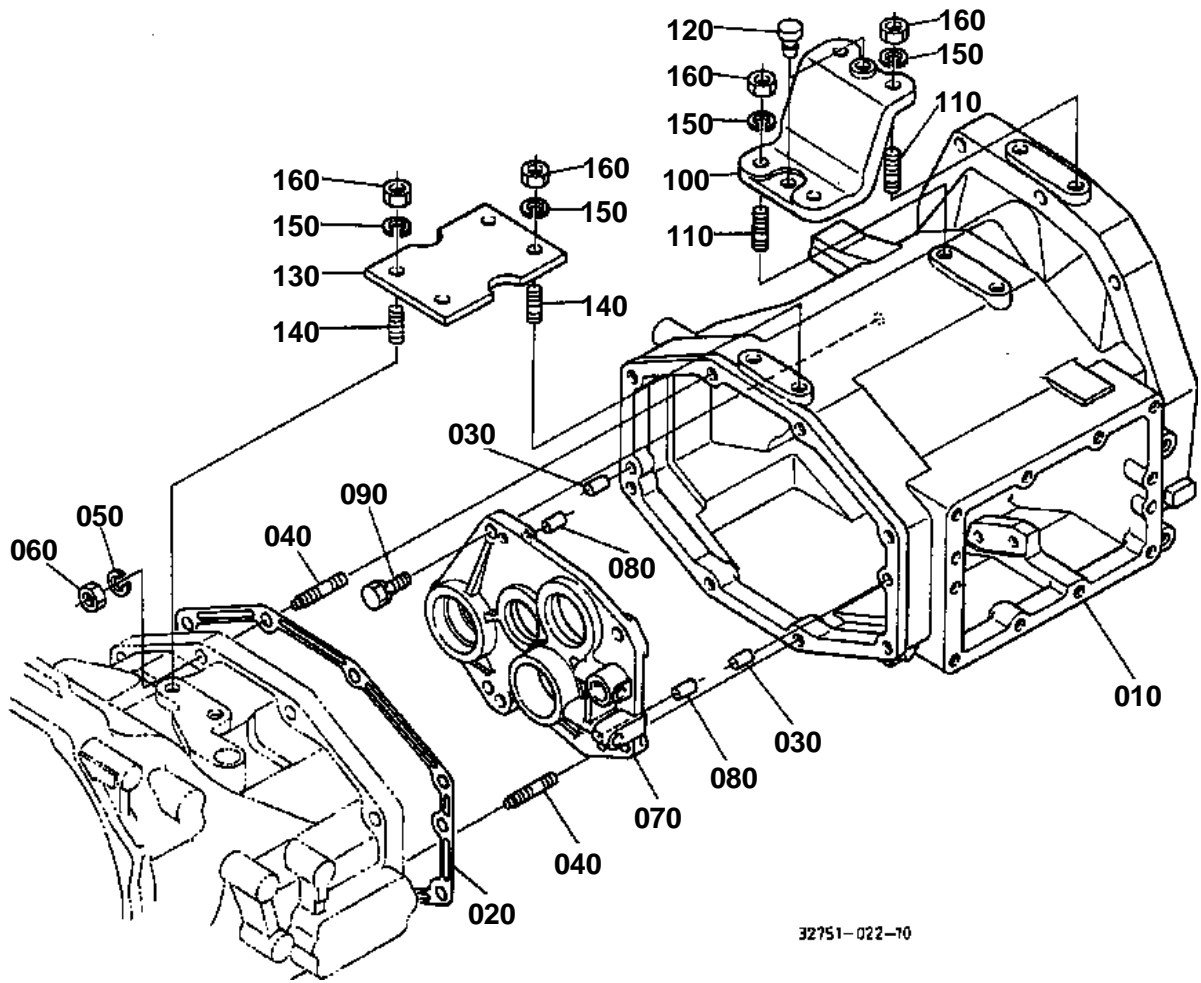

32751-022-10

**MID CASE**

↔ Interchangeable; ≠ not interchangeable; ← new for old; → old for new

REF.No	Part No.	Description	Q'ty	S.No.	I/C	REMARKS	Weight (kgf)	Weight (lb)
010	32751-60300	CASE MID	1	<=60285			0	0
010	32751-60303	CASE MID	1	>=60286	↔		31.5	69.3
020	32751-60310	GASKET	1				0.036	0.0792
030	05012-01018	PIN STRAIGHT	2				0.012	0.0264
040	35340-14182	STUD	8				0.05	0.11
050	04512-50120	WASHER SPRING	8				0	0
060	32580-43160	NUT	8				0.014	0.0308
070	32751-60350	HOLDER BEARING	1				3.2	7.04
080	05012-00818	PIN STRAIGHT	2				0.013	0.0286
090	01133-51035	BOLT	4				0.03	0.066
100	32751-60320	PLATE	1				1.185	2.607
110	01574-51230	STUD	4				0.037	0.0814
110	01574-61230	STUD	4		↔		0.036	0.0792
120	38240-29870	CUSHION	2				0.004	0.0088
130	32751-60330	PLATE	1				0.51	1.122
140	01574-51225	STUD	4				0.034	0.0748
150	04512-50120	WASHER SPRING	8				0	0
160	02176-50120	NUT	8				0.01	0.022

TRANSMISSION CASE

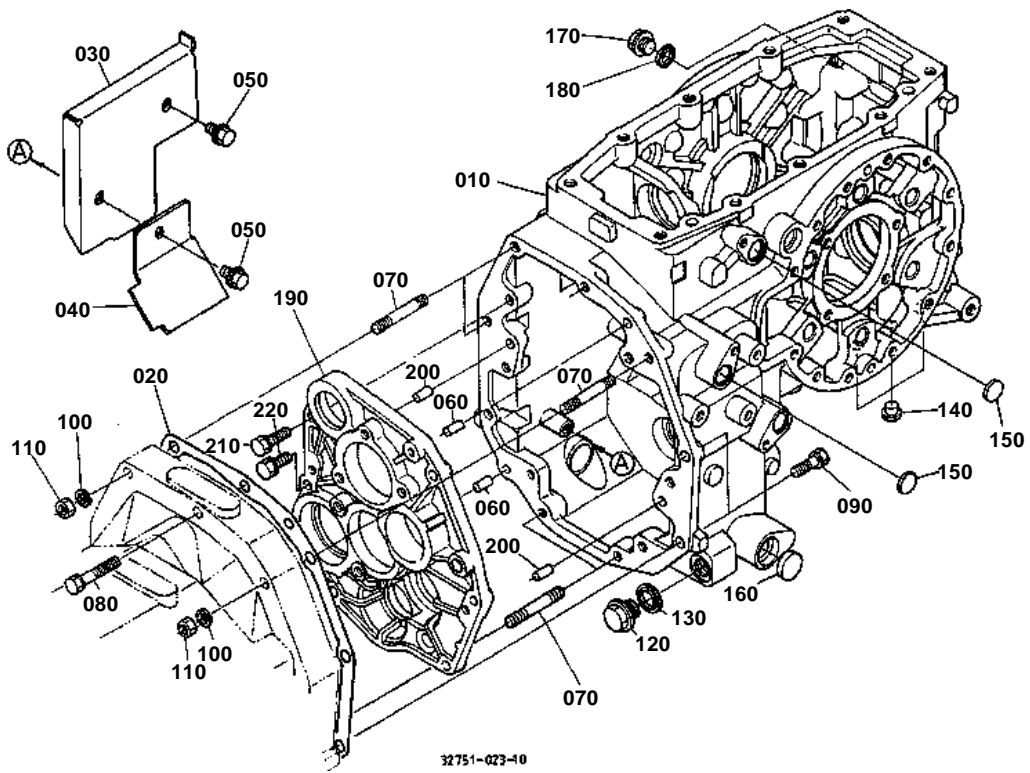



TRANSMISSION CASE

↔ Interchangeable; ≠ not interchangeable; ← new for old; → old for new

REF.No	Part No.	Description	Q'ty	S.No.	I/C	REMARKS	Weight (kgf)	Weight (lb)
010	32751-20400	CASE TRANSMISSION	1	<=60504			0	0
010	32751-20403	CASE TRANSMISSION	1	>=60505	↔		42.5	93.5
020	32751-20420	GASKET	1				0.015	0.033
030	32751-20430	PLATE OIL	1				0.395	0.869
040	32751-20440	PLATE OIL	1				0.09	0.198
050	01754-50816	BOLT FLANGE	2				0.011	0.0242
060	05012-01018	PIN STRAIGHT	2				0.012	0.0264
070	37150-27350	STUD	5				0.06	0.132
080	01133-51260	BOLT	2				0.06	0.132
090	01133-51235	BOLT	2				0.043	0.0946
100	04512-50120	WASHER SPRING	5				0	0
110	02176-50120	NUT	5				0.01	0.022
120	15512-96010	PLUG DRAIN	1				0.101	0.2222
130	04717-02150	WASHER WITH RUBBER	1				0.004	0.0088
140	31220-14290	PLUG	8				0.002	0.0044
150	34076-60470	PLUG	2				0.005	0.011
160	62182-14340	PLUG	1				0.01	0.022
160	69331-11160	PLUG	1		↔		0.008	0.0176
170	06311-25030	PLUG	1				0.051	0.1122
180	04717-01700	WASHER WITH RUBBER	1				0.003	0.0066
190	32751-60450	HOLDER BEARING	1				4.5	9.9
200	05012-01018	PIN STRAIGHT	2				0.012	0.0264
210	01133-51035	BOLT	5				0.03	0.066
220	01133-51040	BOLT	1				0.03	0.066

MAIN SHAFT

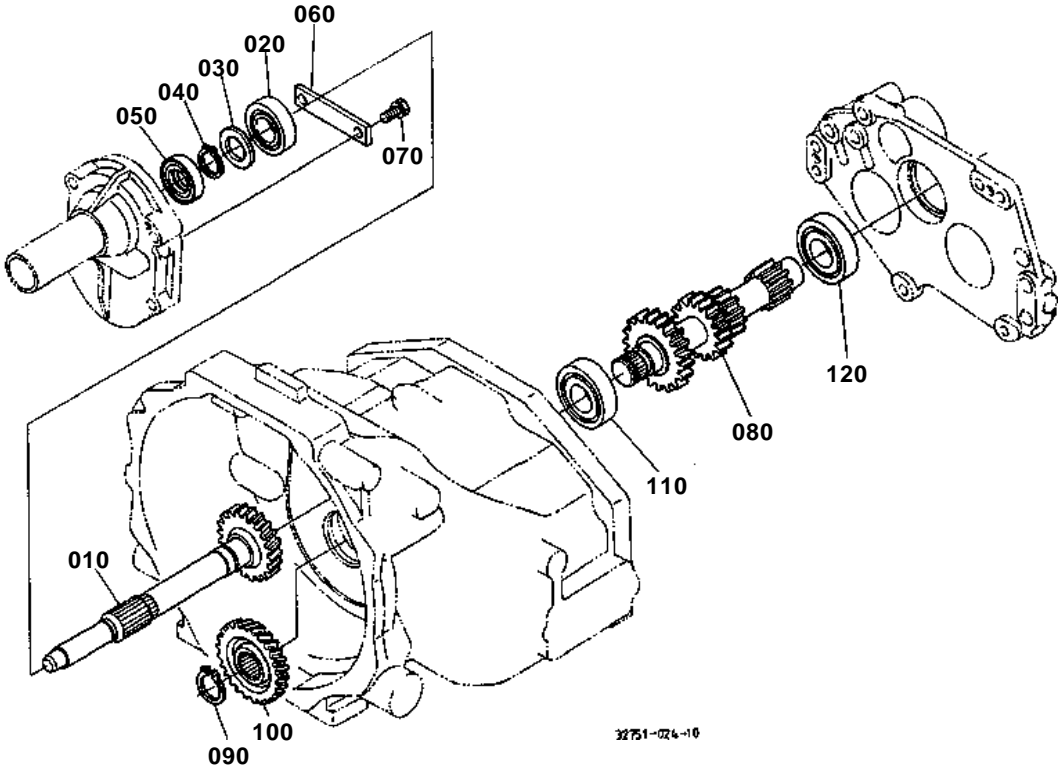



MAIN SHAFT

↔ Interchangeable; ≠ not interchangeable; ← new for old; → old for new

REF.No	Part No.	Description	Q'ty	S.No.	I/C	REMARKS	Weight (kgf)	Weight (lb)
010	32751-21330	GEAR-SHAFT	1			21T	1.11	2.442
020	37410-57190	BEARING BALL	1				0.14	0.308
030	34150-21560	WASHER	1				0.01	0.022
040	37150-21551	CIRCLIP EXTERNAL	1				0.005	0.011
050	09500-25408	SEAL OIL	1				0.01	0.022
060	32751-21320	STOPPER	1				0.032	0.0704
070	01123-50818	BOLT	2				0.012	0.0264
080	32751-22100	GEAR-SHAFT MAIN	1			22-18-13-10T	1.7	3.74
090	37150-21551	CIRCLIP EXTERNAL	1				0.005	0.011
100	32751-22130	GEAR	1			30T	0.6	1.32
110	32751-22320	BEARING BALL	1				0.285	0.627
120	35890-41290	BEARING BALL	1				0.233	0.5126

COUNTERSHAFT

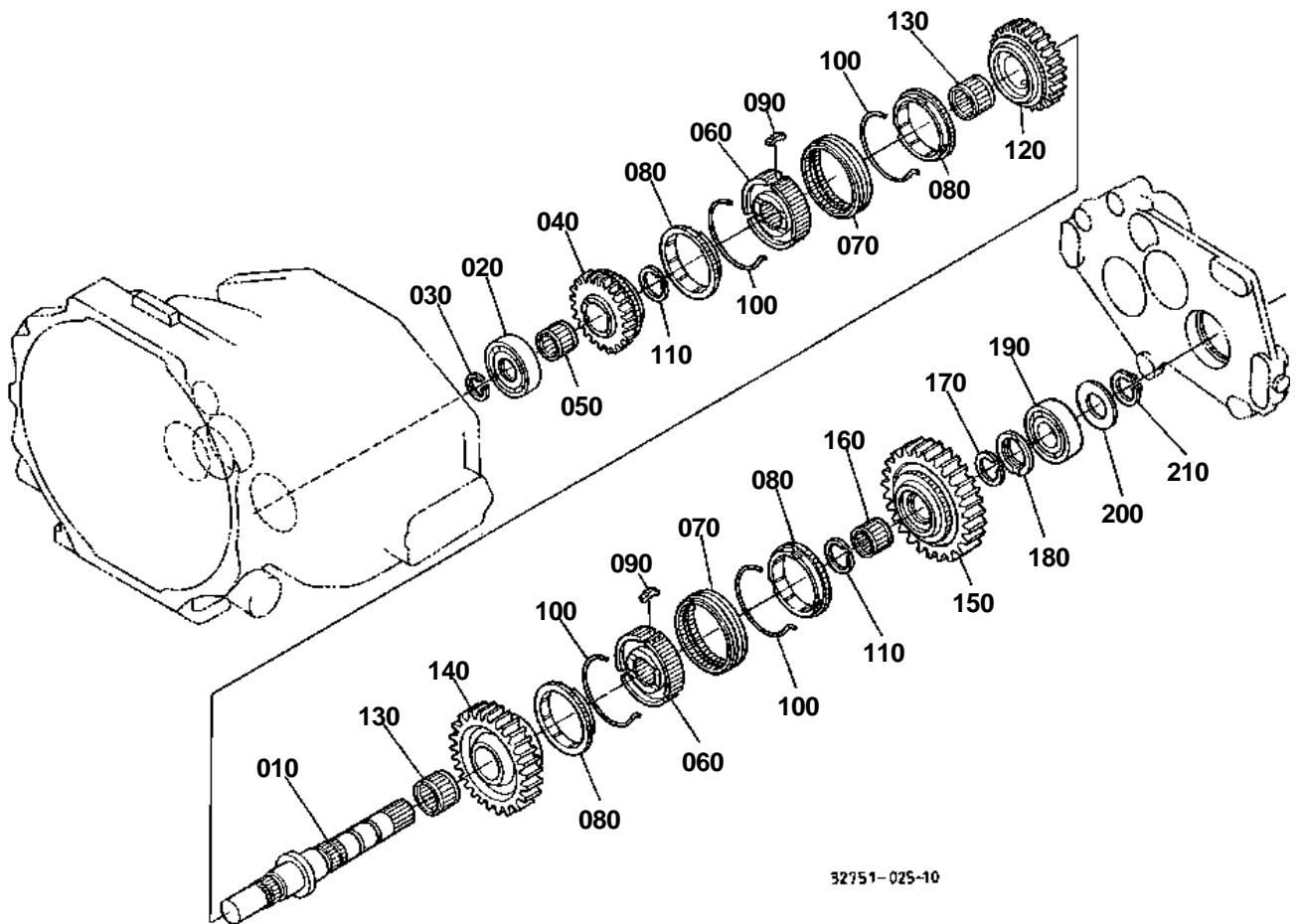



COUNTERSHAFT

↔ Interchangeable; ≠ not interchangeable; ← new for old; → old for new

REF.No	Part No.	Description	Q'ty	S.No.	I/C	REMARKS	Weight (kgf)	Weight (lb)
010	32751-22200	COUNTERSHAFT	1				1.165	2.563
020	34070-22260	BEARING BALL	1				0.235	0.517
030	04611-00250	CIR CLIP INTERNAL	1				0.001	0.0022
040	32751-62210	GEAR	1			24T	0.655	1.441
050	T0073-62310	BEARING NEEDLE	1				0.021	0.0462
060	TA040-22250	COUPLING	2				0.33	0.726
070	34076-62252	SHIFTER	2	<=60045			0	0
070	34076-62253	SHIFTER	2	>=60046	-		0.235	0.517
080	34076-62260	RING SYNCHRONIZER	4				0.05	0.11
090	32430-21440	KEY SYNCHRONIZER	6				0.004	0.0088
100	38360-21780	SPRING	4				0.001	0.0022
110	37410-14540	CIR-CLIP	2				0.03	0.066
120	TA040-22220	GEAR	1			29T	0.84	1.848
130	08823-23727	BEARING NEEDLE	2				0.04	0.088
140	T0073-62230	GEAR	1			34T	1.13	2.486
150	T0073-62240	GEAR	1			37T	1.46	3.212
160	T0073-62320	BEARING NEEDLE	1				0.025	0.055
170	37150-21790	CIR-CLIP	1				0.001	0.0022
180	34070-22250	COLLAR THRUST	1				0.015	0.033
190	08101-06305	BEARING BALL	1				0.23	0.506
200	34150-21560	WASHER	1				0.01	0.022
210	37150-21551	CIRCLIP EXTERNAL	1				0.005	0.011

HYDRAULIC CLUTCH

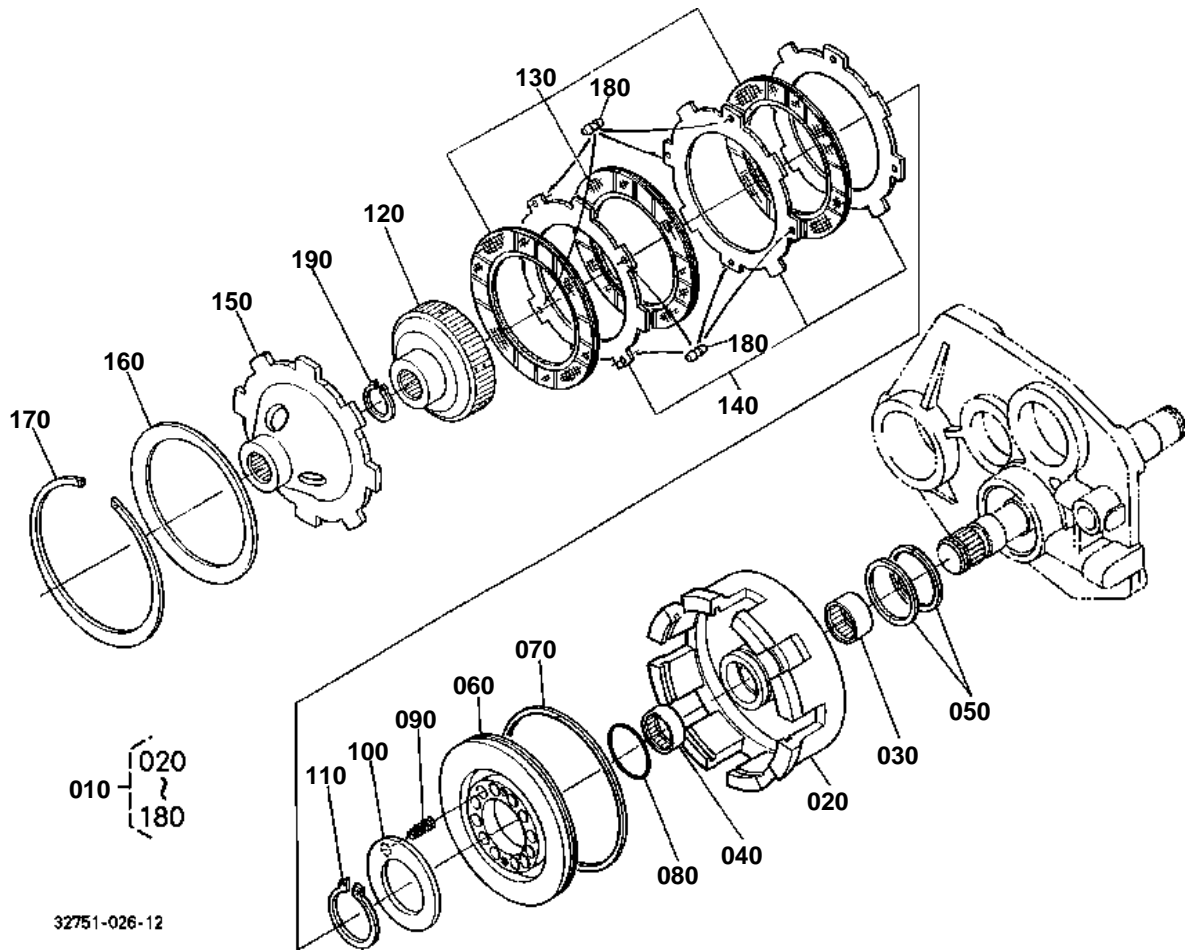

145 34076-6169-0
145 T1063-6167-0

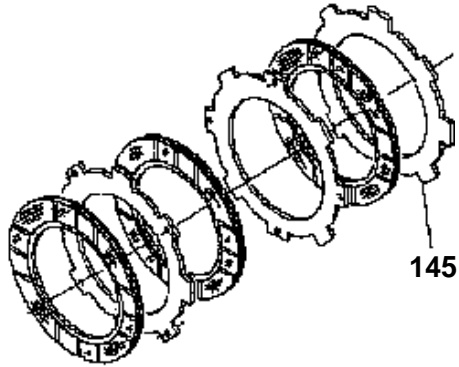

32751-830-10



HYDRAULIC CLUTCH

↔ Interchangeable; ≠ not interchangeable; ← new for old; → old for new

REF.No	Part No.	Description	Q'ty	S.No.	I/C	REMARKS	Weight (kgf)	Weight (lb)
010	TA040-61500	ASSY CLUTCH	1	<=60878		NOT SALE	3.5	7.7
010	TA040-61502	ASSY CLUTCH	1	>=60879	-	NOT SALE	0	0
010	TA040-61504	ASSY CLUTCH	1	>=64590	-		0	0
010	TA040-61507	ASSY CLUTCH	1	>=73113	-		3.5	7.7
020	TA040-61510	CASE CLUTCH	1	<=60878		NOT SALE	1.37	3.014
020	TA040-61550	CASE CLUTCH	1	>=60879	-		1.45	3.19
030	34076-61530	BEARING NEEDLE	1				0.04	0.088
040	34076-61540	BEARING NEEDLE	1				0.01	0.022
050	31501-72400	RING SEAL	2	<=61745			0	0
050	31501-72403	SEALING	2	>=61746	-		0.005	0.011
060	34076-61560	PISTON	1				0.26	0.572
070	34076-61570	D RING OUTER	1				0.005	0.011
080	04811-06370	O RING	1				0	0
080	04816-06370	O RING	1		«		0.003	0.0066
090	34076-61590	SPRING	12				0.005	0.011
100	34076-61610	PLATE RETAINER	1				0.035	0.077
110	04612-00420	CIRCLIP EXTERNAL	1				0.006	0.0132
120	34076-61630	HUB CLUTCH	1				0.455	1.001
130	34076-61650	DISK CLUTCH	3	<=64589			0	0
130	T0273-61650	DISK CLUTCH	3	>=64590	-		0.075	0.165
140	34076-61660	PLATE	2			1.6mm	0	0
140	T1063-61660	PLATE STEEL	2	<=73230	«	1.6mm	0.07	0.154
140	T1063-61660	PLATE	3	>=73231		1.6mm	0.07	0.154
145	34076-61690	PLATE	1			1.6mm	0	0
145	T1063-61670	PLATE STEEL	1		«	1.6mm	0.073	0.1606
145	T1063-61670	PLATE	1	<=73230		1.6mm	0.073	0.1606
150	34076-61710	HUB CLUTCH INPUT	1				0.7	1.54
160	34076-61680	SPRING PLATE	1	<=72896			0	0
160	34076-61680	SPRING PLATE	1	>=72897	-		0	0
170	TA040-61720	CIR-CLIP INTERNAL	1				0	0
170	TD060-61720	CIR CLIP INTERNAL	1		«		0.08	0.176
180	34076-61670	RUBBER	8				0.005	0.011
190	37150-21551	CIRCLIP EXTERNAL	1				0.005	0.011

SHUTTLE SHAFT

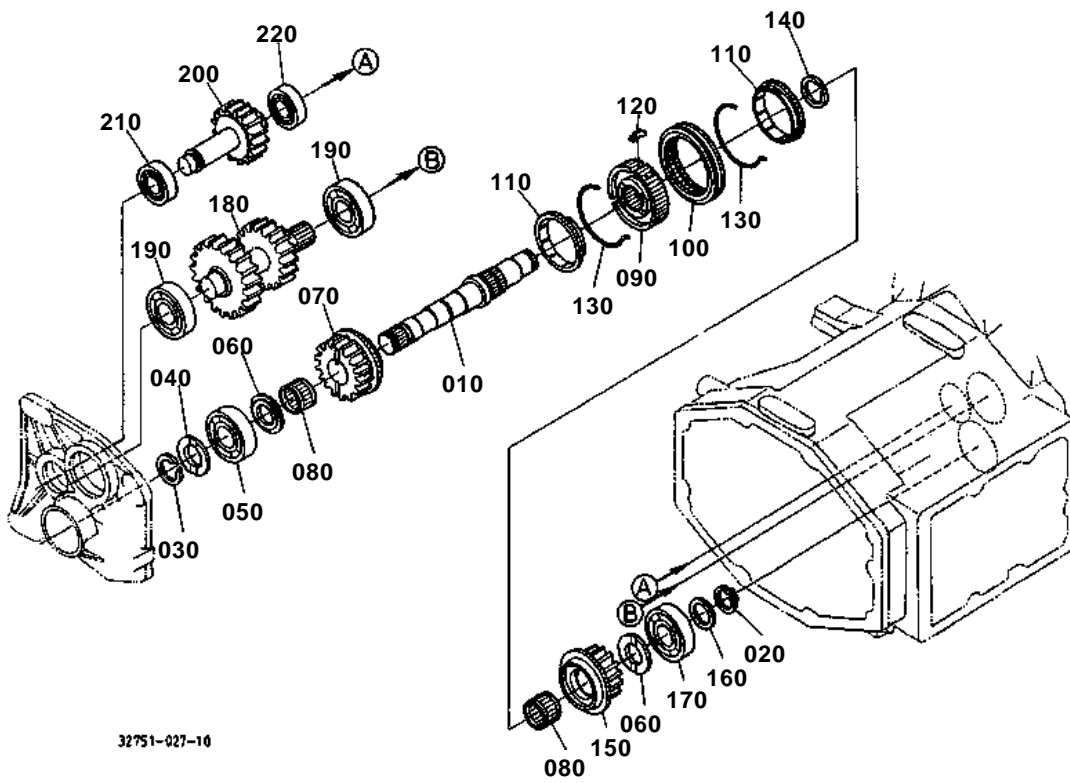



SHUTTLE SHAFT

↔ Interchangeable; ≠ not interchangeable; ← new for old; → old for new

REF.No	Part No.	Description	Q'ty	S.No.	I/C	REMARKS	Weight (kgf)	Weight (lb)
010	TA040-62400	SHAFT SHUTTLE	1				0.98	2.156
020	37150-21551	CIRCLIP EXTERNAL	1				0.005	0.011
030	37150-21790	CIR-CLIP	1				0.001	0.0022
040	34070-15710	COLLAR THRUST	1				0.021	0.0462
050	35890-41290	BEARING BALL	1				0.233	0.5126
060	TA040-22430	COLLAR THRUST	2				0.022	0.0484
070	TA040-62410	GEAR	1			18T	0.685	1.507
080	34070-22430	BEARING NEEDLE	2				0.035	0.077
090	TA040-22450	COUPLING	1				0.3	0.66
100	TA040-22440	SHIFTER	1				0.225	0.495
110	32430-67630	RING SYNCHRONIZER	2				0.055	0.121
120	32430-21440	KEY SYNCHRONIZER	3				0.004	0.0088
130	38360-21780	SPRING	2				0.001	0.0022
140	34076-62460	CIRCLIP EXTERNAL	1				0.005	0.011
150	TA040-62420	GEAR	1			15T	0.48	1.056
160	34150-21560	WASHER	1				0.01	0.022
170	32751-22310	BEARING BALL	1				0.225	0.495
180	32751-22500	GEAR-SHAFT SHUTTLE	1			22-20T	2	4.4
190	35890-41290	BEARING BALL	2				0.233	0.5126
200	TA040-22550	GEAR-SHAFT BACK	1			17T	0.885	1.947
210	08101-06204	BEARING BALL	1				0.102	0.2244
220	34070-22560	BEARING BALL	1				0.1	0.22

RANGE GEAR SHAFT

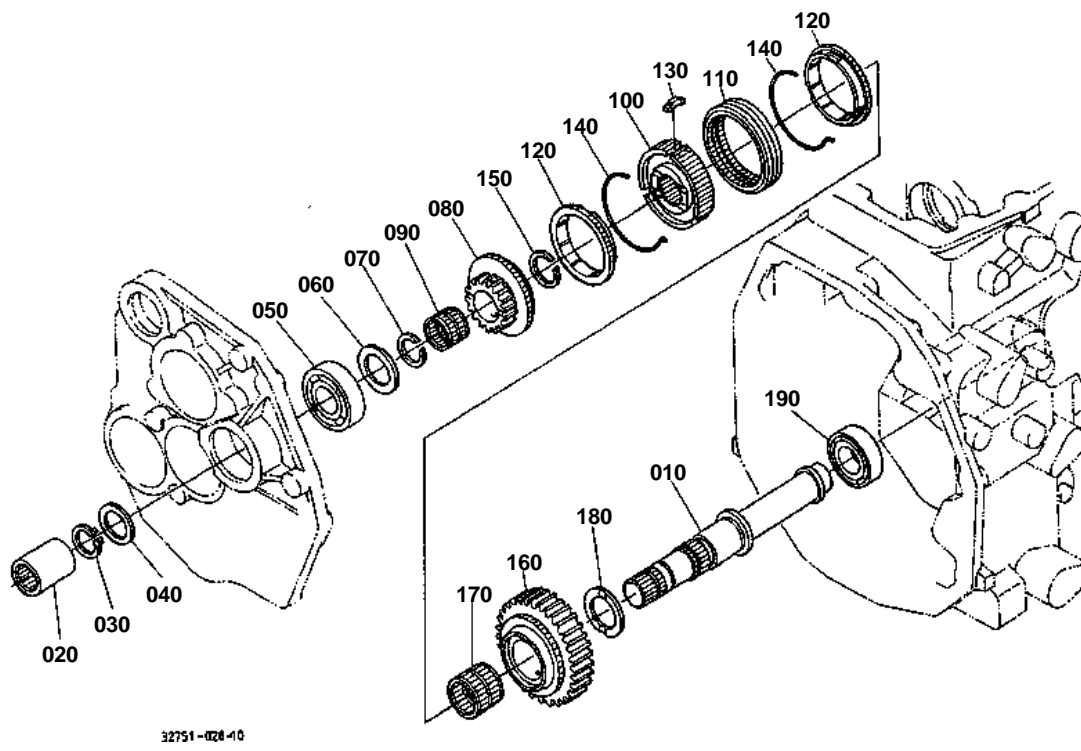



RANGE GEAR SHAFT

↔ Interchangeable; ≠ not interchangeable; ← new for old; → old for new

REF.No	Part No.	Description	Q'ty	S.No.	I/C	REMARKS	Weight (kgf)	Weight (lb)
010	TA040-22600	SHAFT RANGE GEAR	1				1.14	2.508
020	34070-22670	COUPLING	1				0.165	0.363
020	TD060-22670	COUPLING	1			«	0.16	0.352
030	37150-21551	CIRCLIP EXTERNAL	1				0.005	0.011
040	34150-21560	WASHER	1				0.01	0.022
050	08101-06305	BEARING BALL	1				0.23	0.506
060	34076-62650	COLLAR THRUST	1				0.01	0.022
070	37150-21790	CIR-CLIP	1				0.001	0.0022
080	TA040-62610	GEAR	1			18T	0.34	0.748
090	TA040-22630	BEARING NEEDLE	1				0.02	0.044
100	TA040-22250	COUPLING	1				0.33	0.726
110	34076-62252	SHIFTER	1	<=60045			0	0
110	34076-62253	SHIFTER	1	>=60046	-		0.235	0.517
120	34076-62260	RING SYNCHRONIZER	2				0.05	0.11
130	32430-21440	KEY SYNCHRONIZER	3				0.004	0.0088
140	38360-21780	SPRING	2				0.001	0.0022
150	37410-14540	CIR-CLIP	1				0.03	0.066
160	TA040-62620	GEAR	1			33T	1.39	3.058
170	TA040-22640	BEARING NEEDLE	1				0.05	0.11
180	38450-23230	COLLAR	1				0.024	0.0528
190	08101-06205	BEARING BALL	1				0.14	0.308

PTO COUNTERSHAFT AND ONE WAY CLUTCH

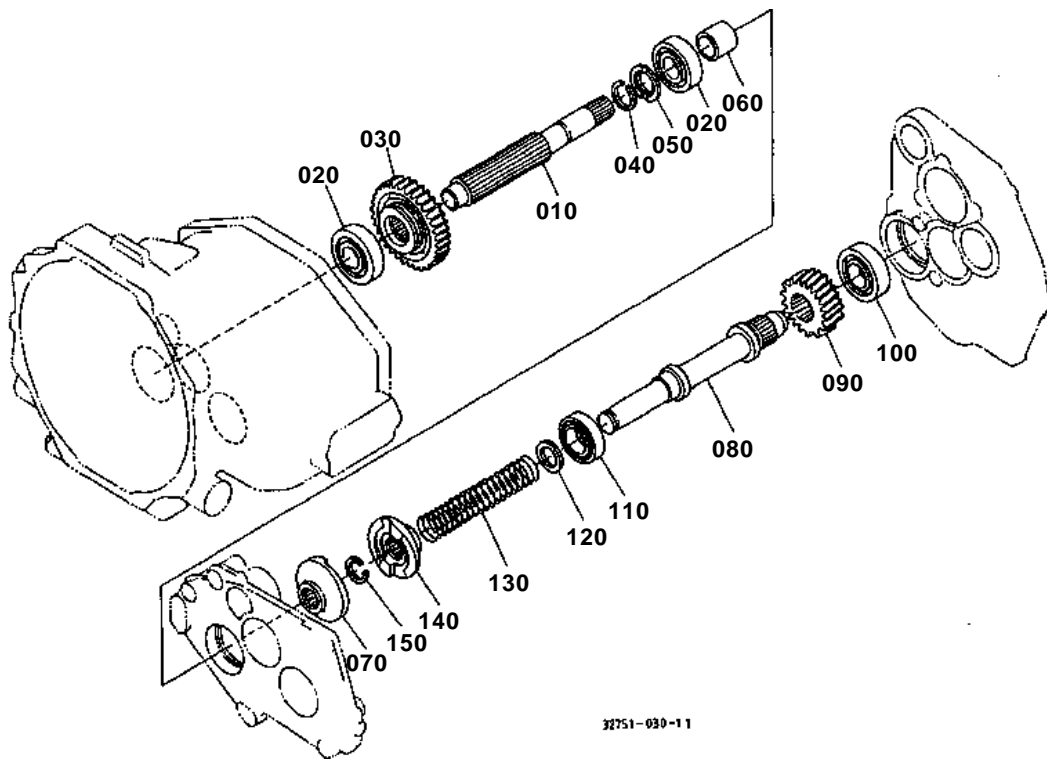

32751-030-11

150 37150-2155-1

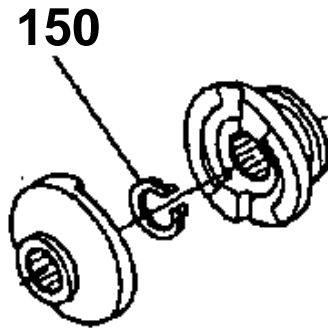

32751-803-10



PTO COUNTERSHAFT AND ONE WAY CLUTCH

↔ Interchangeable; ≠ not interchangeable; ← new for old; → old for new

REF.No	Part No.	Description	Q'ty	S.No.	I/C	REMARKS	Weight (kgf)	Weight (lb)
010	34070-23200	COUNTERSHAFT PTO	1				1.345	2.959
020	08101-06305	BEARING BALL	2				0.23	0.506
030	34070-22230	GEAR	1	<=63208		34T	0	0
030	T0320-23220	GEAR	1	>=63209	-	34T	1.095	2.409
040	37150-21551	CIRCLIP EXTERNAL	1				0.005	0.011
050	61145-14360	WASHER CLUTCH	1				0.01	0.022
060	32580-44220	COLLAR	1				0.07	0.154
070	TA040-23400	CAM CLUTCH	1	<=61182			0.48	1.056
070	TA040-23402	CAM CLUTCH	1	>=61183	1		0.25	0.55
080	32751-23500	SHAFT	1	<=61182			1.82	4.004
080	32751-23502	SHAFT	1	>=61183	1		1.82	4.004
090	34070-23510	GEAR	1	<=60189		20T	0	0
090	34070-23512	GEAR	1	>=60190	-	20T	0.655	1.441
100	38450-25350	BEARING BALL	1				0.345	0.759
110	08101-06228	BEARING BALL	1				0.18	0.396
120	34150-21560	WASHER	1				0.01	0.022
130	35200-25230	SPRING ONE-WAY	1				0.075	0.165
140	TA040-23400	CAM CLUTCH	1	<=61182			0.48	1.056
140	TA040-23402	CAM CLUTCH	1	>=61183	1		0.25	0.55
150	37150-21551	CIRCLIP EXTERNAL	1	<=61182			0.005	0.011
150	38430-21550	CIR CLIP	1	>=61183	1		0.005	0.011

PTO SHAFT

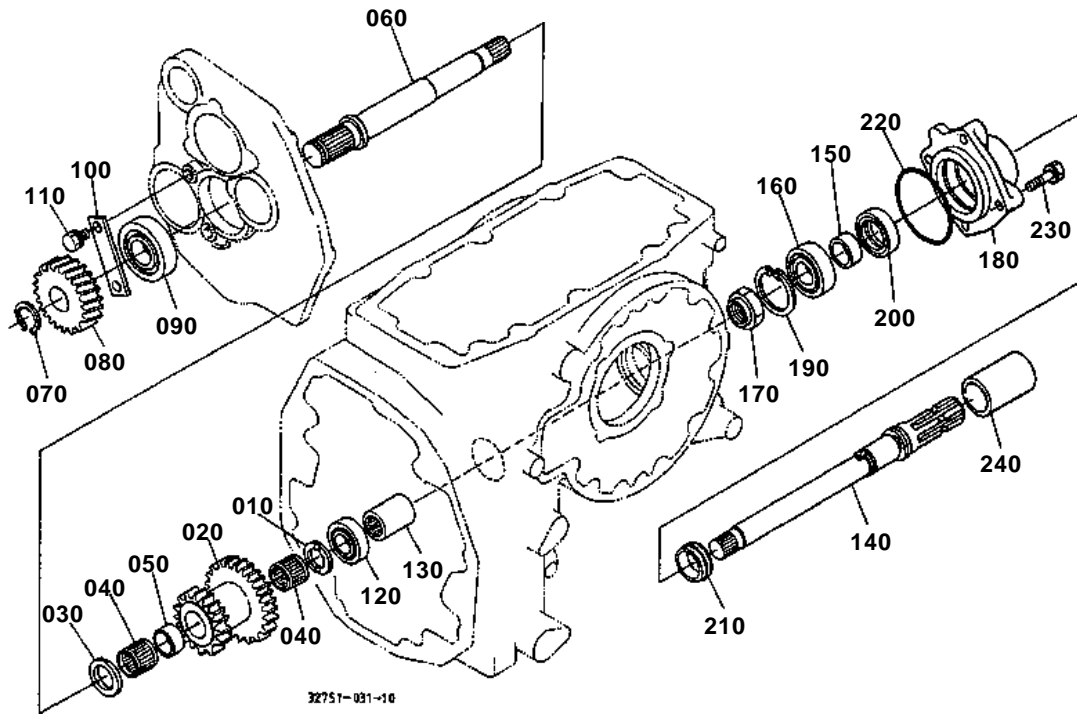



PTO SHAFT

↔ Interchangeable; ≠ not interchangeable; ← new for old; → old for new

REF.No	Part No.	Description	Q'ty	S.No.	I/C	REMARKS	Weight (kgf)	Weight (lb)
010	34070-15710	COLLAR THRUST	1				0.021	0.0462
020	32751-15120	GEAR	1	<=50868		20-25T	0	0
020	32751-15122	GEAR	1	>=60001	-	20-25T	1.105	2.431
030	30420-74310	COLLAR THRUST	1				0.015	0.033
040	08822-83327	BEARING NEEDLE	2				0.034	0.0748
050	34070-15130	COLLAR	1				0.01	0.022
060	34070-23600	SHAFT PTO DRIVE	1	<=61401			0	0
060	34070-23602	SHAFT PTO DRIVE	1	>=61402	-		1.48	3.256
070	31351-21930	CIR-CRIP EXTERNAL	1				0.004	0.0088
080	34070-23610	GEAR	1	<=60189		22T	0	0
080	34070-23612	GEAR	1	>=60190	-	22T	0.86	1.892
090	36540-41130	BEARING BALL	1				0.34	0.748
100	34070-21320	STOPPER	1				0.055	0.121
110	01123-50825	BOLT	2				0.013	0.0286
120	67121-56770	BEARING BALL	1				0.127	0.2794
130	37150-21682	COUPLING	1				0.24	0.528
140	34070-23700	SHAFT PTO	1				1.985	4.367
150	37300-25350	COLLAR OIL SEAL	1				0.032	0.0704
160	08101-06206	BEARING BALL	1				0.196	0.4312
170	34150-25320	NUT	1				0.03	0.066
180	38260-25412	CASE BEARING	1				1.1	2.42
190	04611-00620	CIR CLIP INTERNAL	1				0.011	0.0242
200	37150-25360	SEAL OIL	1				0.025	0.055
210	38240-25370	SLINGER	1				0.004	0.0088
220	04811-50800	O RING	1				0.003	0.0066
230	01123-50832	BOLT	4				0.016	0.0352
240	31220-25820	CAP	1				0.055	0.121

MAIN GEAR SHIFT LEVER

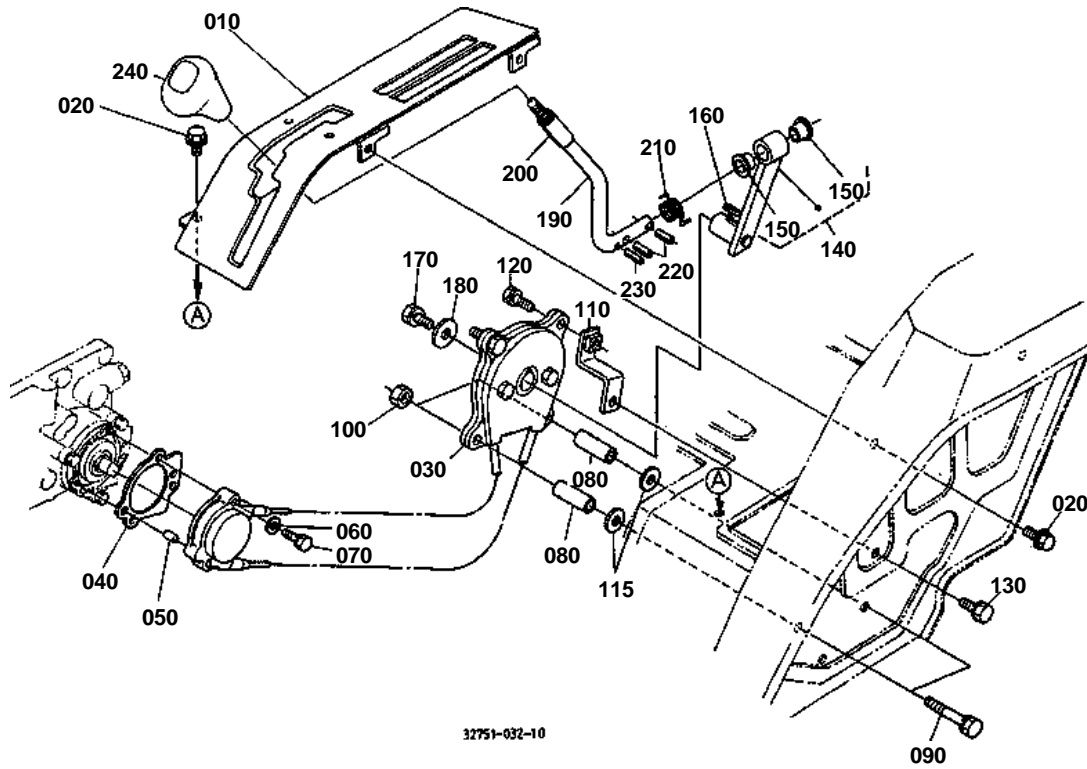



MAIN GEAR SHIFT LEVER

↔ Interchangeable; ≠ not interchangeable; ← new for old; → old for new

REF.No	Part No.	Description	Q'ty	S.No.	I/C	REMARKS	Weight (kgf)	Weight (lb)
010	T0043-47100	GUIDE SHIFT	1				0.96	2.112
020	01754-50812	BOLT FLANGE	4				0.01	0.022
030	34076-64800	ASSY CABLE SHIFT	1	<=63047			0	0
030	34076-64803	ASSY CABLE SHIFT	1	>=63048	-		1.61	3.542
040	32425-72690	GASKET	1				0.002	0.0044
050	05012-00608	PIN STRAIGHT	2				0.002	0.0044
060	04013-50060	WASHER PLAIN	3				0	0
070	01023-50628	BOLT	3				0.015	0.033
080	34076-64560	COLLAR	2				0.03	0.066
090	01123-50890	BOLT	2				0.04	0.088
100	02114-50080	NUT	2				0.005	0.011
110	34076-64570	STAY	1				0.07	0.154
115	04015-50080	WASHER PLAIN	2				0	0
120	01123-50835	BOLT	1				0.02	0.044
130	01123-50816	BOLT	1				0	0
140	34076-64550	ASSY LEVER SHIFT	1				0.28	0.616
150	34076-64540	BUSH	2				0.005	0.011
160	05712-00520	KEY FEATHER	1				0.004	0.0088
170	01123-50816	BOLT	1				0	0
180	04015-50080	WASHER PLAIN	1				0	0
190	32751-64510	LEVER SHIFT	1				0.305	0.671
200	31391-24510	PIPE LEVER	1				0.005	0.011
210	34076-64530	SPRING	1				0.01	0.022
220	05411-00525	PIN SPRING	2				0.002	0.0044
230	05411-00320	PIN SPRING	1				0.001	0.0022
240	TA040-69820	GRIP LEVER	1				0.117	0.2574

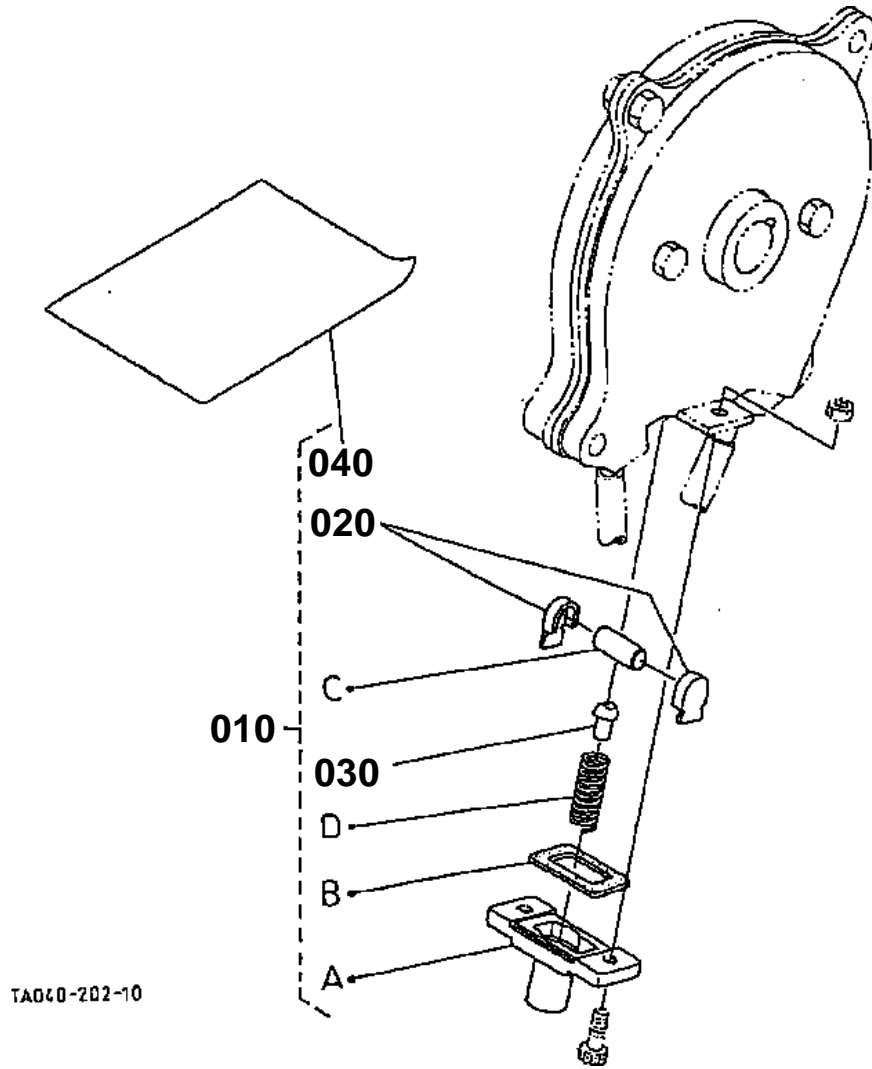

TAD60-202-10



GST SHIFT COVER [OPTION]

↔ Interchangeable; ≠ not interchangeable; ← new for old; → old for new

REF.No	Part No.	Description	Q'ty	S.No.	I/C	REMARKS	Weight (kgf)	Weight (lb)
010	34076-99600	ASSY COVER GST	1				0.056	0.1232
020	34076-64920	GUIDE ROLLER	2				0.002	0.0044
030	34076-64930	SUPPORT ROLLER	1				0.004	0.0088
040	99999-99999	MANUAL INSTRUCTION	1				0	0

MAIN GEAR SHIFT FORK

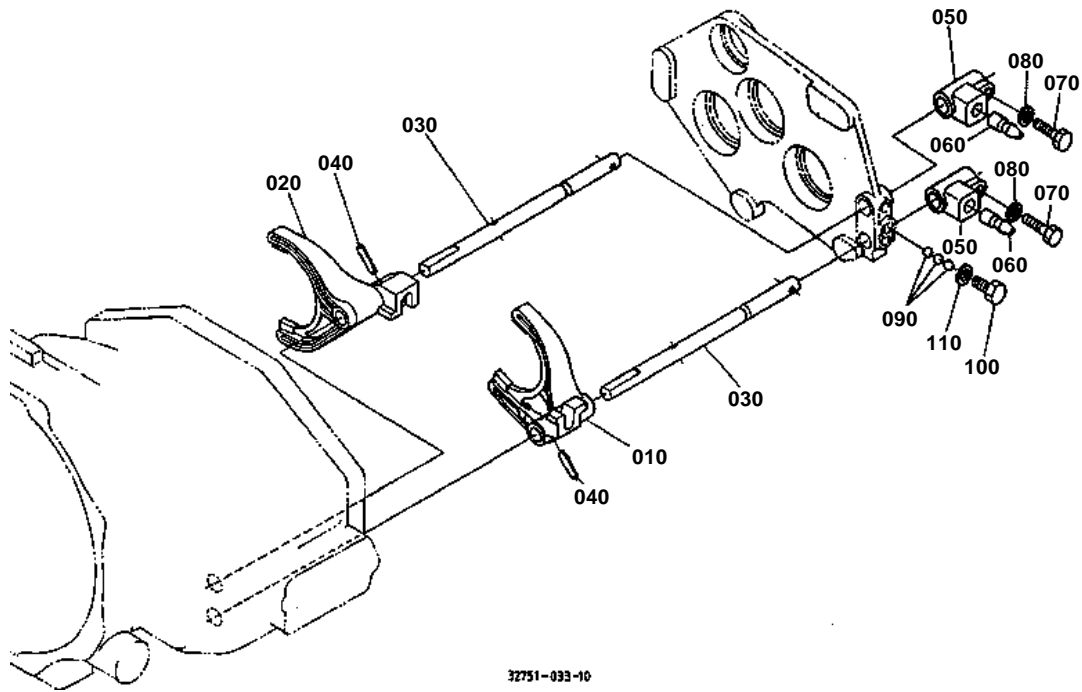



MAIN GEAR SHIFT FORK

↔ Interchangeable; ≠ not interchangeable; ← new for old; → old for new

REF.No	Part No.	Description	Q'ty	S.No.	I/C	REMARKS	Weight (kgf)	Weight (lb)
010	T0073-64103	FORK MAIN SHIFT	1				0.225	0.495
020	T0073-64110	FORK MAIN SHIFT	1				0.23	0.506
030	32751-64120	ROD FORK	2				0.34	0.748
040	05411-00625	PIN SPRING	2				0.004	0.0088
050	34076-64140	SHIFTER	2	<=60722			0	0
050	T0180-64140	SHIFTER	2	>=60723	-		0.125	0.275
060	34076-64170	PIN SHIFT	2				0.02	0.044
070	31351-23570	BOLT FORK LOCK	2				0.007	0.0154
080	04512-60060	WASHER SPRING	2				0.001	0.0022
090	07715-01605	BALL	3				0.003	0.0066
100	34070-24190	BOLT	1				0.015	0.033
110	04512-60100	WASHER SPRING	1				0.002	0.0044

SHUTTLE GEAR SHIFT LEVER

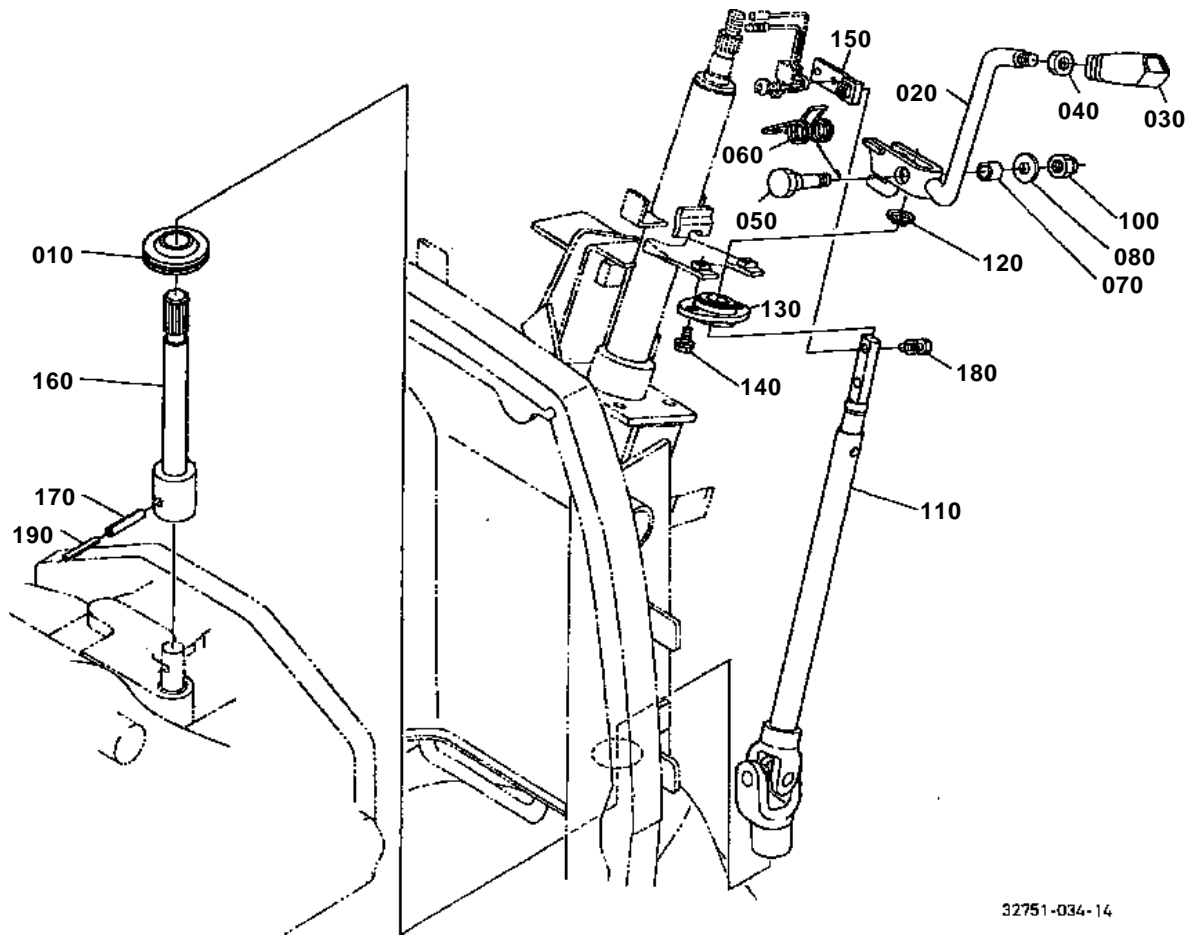

32751-034-14

SHUTTLE GEAR SHIFT LEVER

090 04512-60080

100 02114-50080

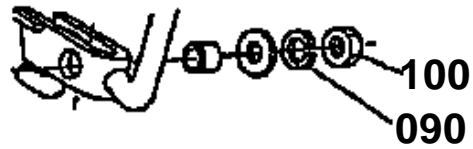

110 TA040-5354-2

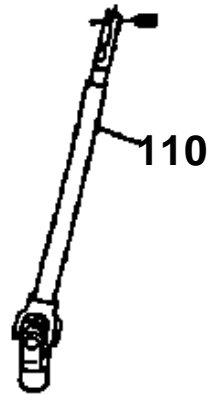

110 TA040-4354-3

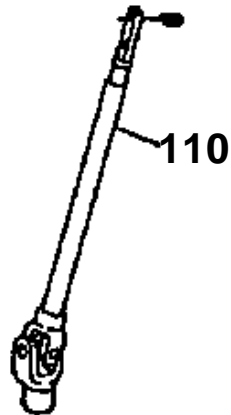

32751-804-11



SHUTTLE GEAR SHIFT LEVER

↔ Interchangeable; ≠ not interchangeable; ← new for old; → old for new

REF.No	Part No.	Description	Q'ty	S.No.	I/C	REMARKS	Weight (kgf)	Weight (lb)
010	34070-43320	GROMMET	1				0.01	0.022
020	TA040-43513	LEVER SHUTTLE	1	<=71191			0	0
020	TA040-43515	LEVER SHUTTLE	1	>=71192	→		0.34	0.748
030	TA040-17472	GRIP LEVER	1				0.027	0.0594
040	02116-50100	NUT	1				0.004	0.0088
050	TA040-43970	BOLT REAMER	1				0.042	0.0924
060	TA040-43940	SPRING	1	<=61377			0	0
060	T0180-43940	SPRING	1	>=61378	→		0	0
060	T0180-43942	SPRING	1	>=61970	→		0.012	0.0264
060	3A211-34562	SPRING	1		«		0.01	0.022
070	TA040-43920	COLLAR SHUTTLE	1				0.005	0.011
080	04013-50080	WASHER PLAIN	1				0	0
090	04512-60080	WASHER SPRING	1	<=72318			0.002	0.0044
100	02114-50080	NUT	1	<=72318			0.005	0.011
100	02552-50080	NUT LOCK	1	>=72319	→		0.005	0.011
110	TA040-43542	JOINT UNIVERSAL	1	<=60045			0	0
110	TA040-43543	JOINT UNIVERSAL	1	>=60046	→		0	0
110	TA040-43544	JOINT UNIVERSAL	1	>=61537	→		0.915	2.013
120	04612-00150	CIRCLIP EXTERNAL	1				0.001	0.0022
130	TA040-43870	BEARING FLANGE	1				0.02	0.044
140	01754-50616	BOLT FLANGE	2				0.006	0.0132
150	TA040-43982	STAY SWITCH	1				0.02	0.044
160	TA040-43532	SHAFT SHUTTLE SHIFT	1	<=50101			0	0
160	TA040-43533	SHAFT SHUTTLE SHIFT	1	>=50102	→		0	0
160	TA040-43534	SHAFT SHUTTLE SHIFT	1	>=61402	→		0.385	0.847
170	05411-00635	PIN SPRING	1	<=62972			0.005	0.011
170	05411-00630	PIN SPRING	1	>=62973	→		0.004	0.0088
180	01023-50620	BOLT	1				0.006	0.0132
190	T0270-15310	PIN SPRING	1	>=62973			0.002	0.0044

SHUTTLE GEAR SHIFT FORK

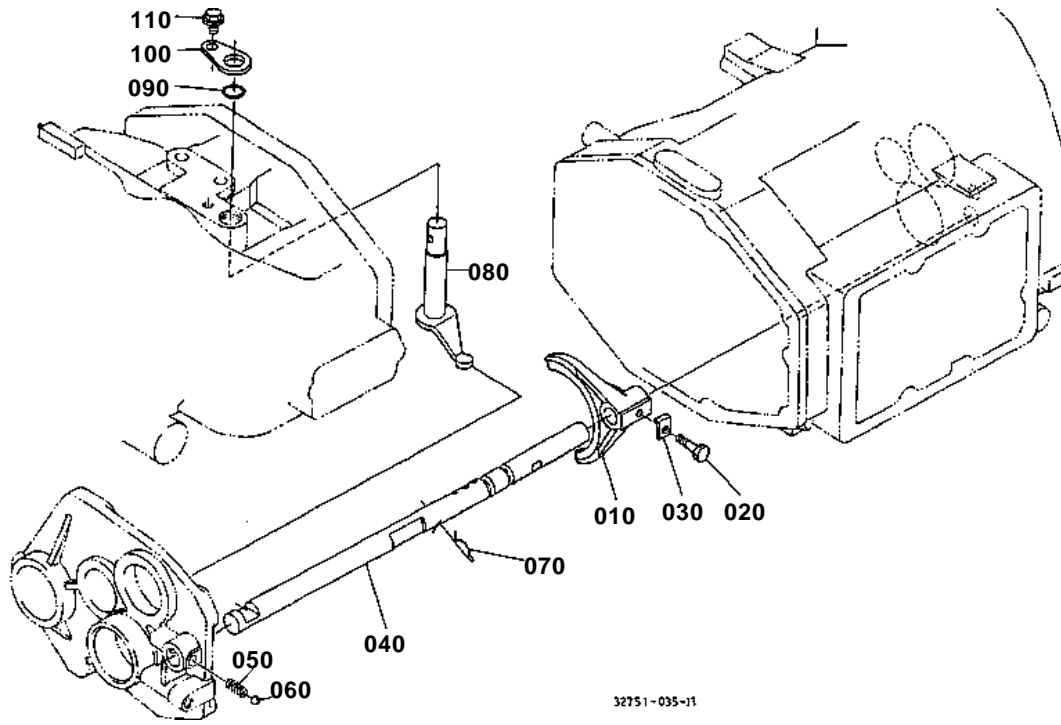



SHUTTLE GEAR SHIFT FORK

↔ Interchangeable; ≠ not interchangeable; ← new for old; → old for new

REF.No	Part No.	Description	Q'ty	S.No.	I/C	REMARKS	Weight (kgf)	Weight (lb)
010	TA040-24300	FORK SHUTTLE SHIFT	1				0.375	0.825
020	34076-64340	BOLT REAMER	1				0.015	0.033
030	32420-67970	WASHER	1				0.002	0.0044
040	32751-64310	ROD FORK	1	<=60878			0	0
040	32751-64312	ROD FORK	1	>=60879	-		0.88	1.936
050	62231-18530	SPRING	1				0.01	0.022
060	07715-01605	BALL	1				0.003	0.0066
070	05515-61200	PIN SNAP	1				0.005	0.011
080	T0070-24320	ARM SHUTTLE SHIFT	1				0.325	0.715
090	04811-00200	O RING	1				0	0
090	04816-00200	O RING	1		-		0.003	0.0066
100	34070-24350	STOPPER	1				0.02	0.044
110	01754-50812	BOLT FLANGE	1				0.01	0.022

RANGE GEAR SHIFT FORK

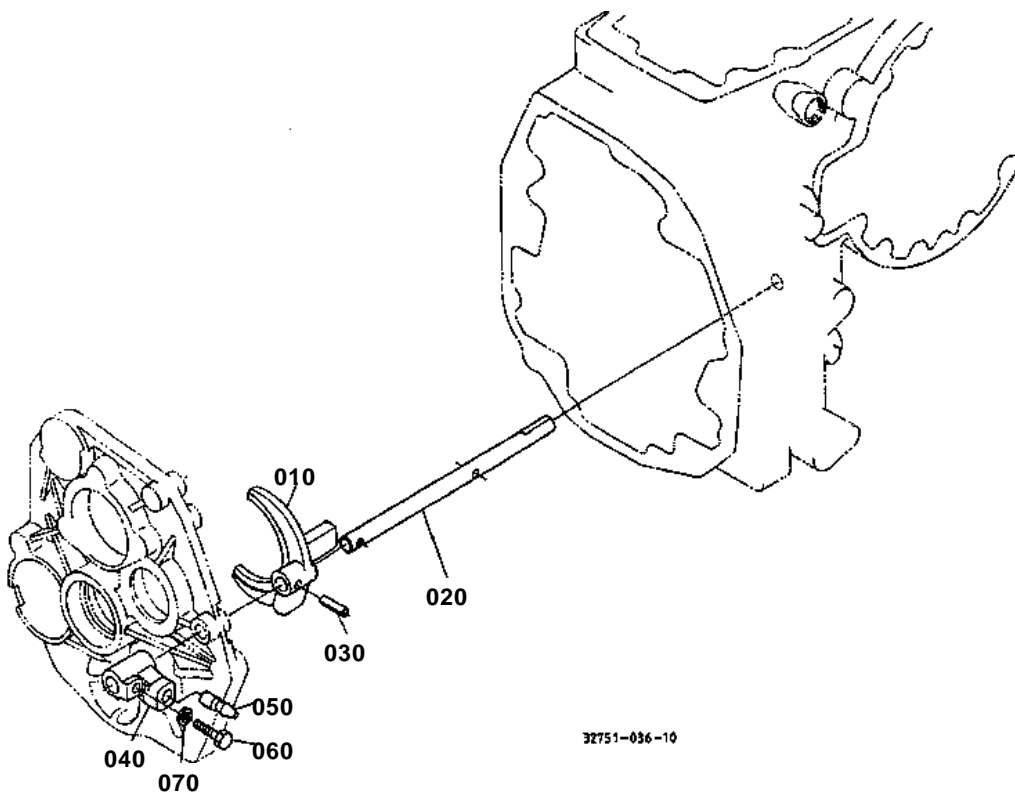

32751-036-10



RANGE GEAR SHIFT FORK

↔ Interchangeable; ≠ not interchangeable; ← new for old; → old for new

REF.No	Part No.	Description	Q'ty	S.No.	I/C	REMARKS	Weight (kgf)	Weight (lb)
010	TA040-64400	FORK RANGE SHIFT	1				0.39	0.858
020	32751-64410	ROD FORK	1				0.3	0.66
030	05411-00625	PIN SPRING	1				0.004	0.0088
040	34076-64420	SHIFTER	1				0.14	0.308
050	34076-64170	PIN SHIFT	1				0.02	0.044
060	31351-23570	BOLT FORK LOCK	1				0.007	0.0154
070	04512-50060	WASHER SPRING	1				0	0

PTO GEAR SHIFT LEVER

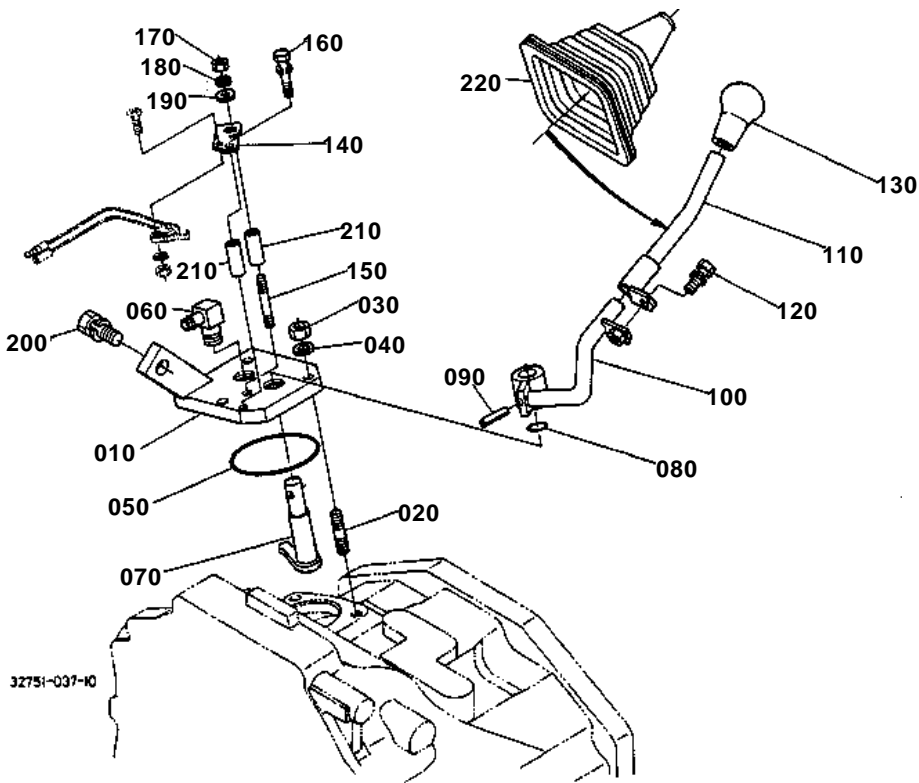



PTO GEAR SHIFT LEVER

↔ Interchangeable; ≠ not interchangeable; ← new for old; → old for new

REF.No	Part No.	Description	Q'ty	S.No.	I/C	REMARKS	Weight (kgf)	Weight (lb)
010	32751-20210	PLATE	1				0.845	1.859
020	01513-50825	STUD	3				0	0
030	02114-50080	NUT	3				0.005	0.011
040	04512-50080	WASHER SPRING	3				0	0
050	04811-50700	O RING	1				0.002	0.0044
060	34070-36910	JOINT	1				0.07	0.154
060	T1270-36910	JOINT	1		«		0.072	0.1584
070	67121-18540	ARM F.WHEEL DRIVE	1				0.125	0.275
080	04811-00140	O RING	1				0	0
080	04816-00140	O RING	1		«		0.002	0.0044
090	05411-00628	PIN SPRING	1				0.004	0.0088
100	32751-24740	LEVER PTO SHIFT	1				0.265	0.583
110	32751-24750	LEVER PTO SHIFT	1				0.16	0.352
120	01123-50820	BOLT	1				0.011	0.0242
130	32751-24930	GRIP LEVER	1				0.04	0.088
140	32751-20220	STAY PTO SWITCH	1				0.012	0.0264
150	15112-91490	STUD	1				0.01	0.022
160	01023-50638	BOLT	1				0.01	0.022
170	02014-50060	NUT	1				0.002	0.0044
180	04512-50060	WASHER SPRING	1				0	0
190	04012-50060	WASHER PLAIN	1				0.001	0.0022
200	01133-51228	BOLT	1				0.04	0.088
210	56713-54240	COLLAR	2				0.008	0.0176
220	34070-43370	BOOT PTO LEVER	1				0.155	0.341

PTO GEAR SHIFT FORK

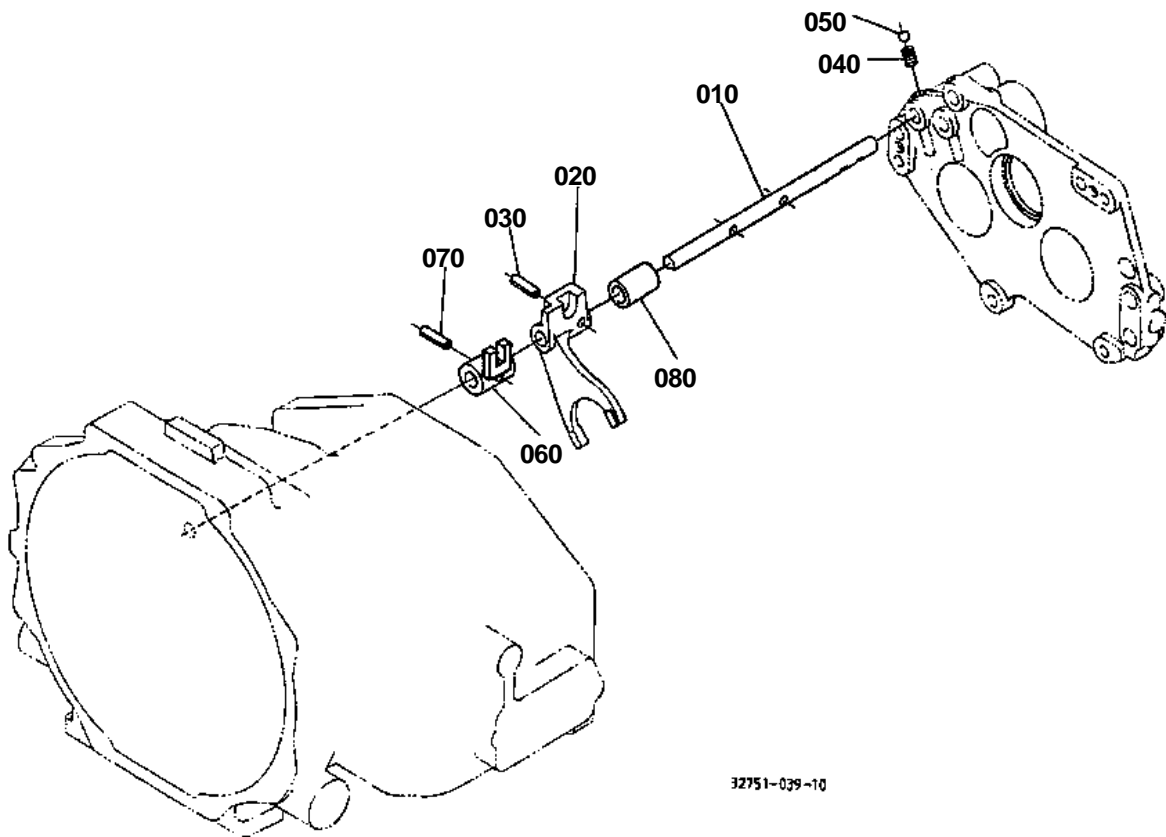

32751-039-10



PTO GEAR SHIFT FORK

↔ Interchangeable; ≠ not interchangeable; ← new for old; → old for new

REF.No	Part No.	Description	Q'ty	S.No.	I/C	REMARKS	Weight (kgf)	Weight (lb)
010	32751-24810	ROD PTO FORK	1				0.2	0.44
020	34070-24710	FORK PTO SHIFT	1				0.245	0.539
030	05411-00525	PIN SPRING	1				0.002	0.0044
040	62231-18530	SPRING	1				0.01	0.022
050	07715-01605	BALL	1				0.003	0.0066
060	32751-24900	SHIFTER PTO	1				0.1	0.22
070	05411-00525	PIN SPRING	1				0.002	0.0044
080	32751-24920	COLLAR	1				0.067	0.1474

SPIRAL BEVEL PINION

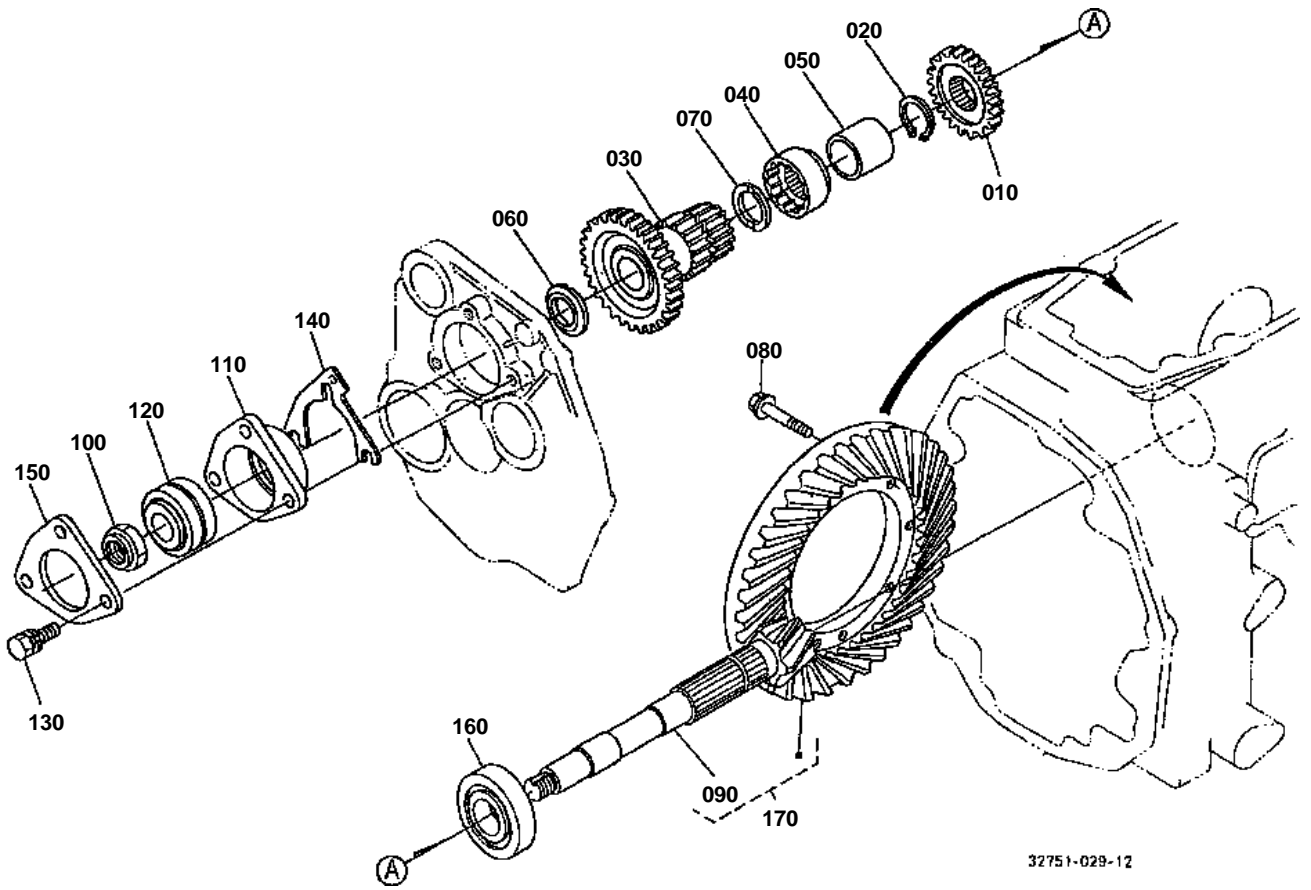

**SPIRAL BEVEL PINION**

↔ Interchangeable; ≠ not interchangeable; ← new for old; → old for new

REF.No	Part No.	Description	Q'ty	S.No.	I/C	REMARKS	Weight (kgf)	Weight (lb)
010	32751-15110	GEAR 4WD	1			23T	0.435	0.957
020	04612-00350	CIRCLIP EXTERNAL	1				0.01	0.022
030	32751-22710	GEAR	1	≤64750		42-16T	0	0
030	32751-22712	GEAR	1	≥64751	↔	42-16T	1.5	3.3
040	32751-22760	COUPLING	1				0.275	0.605
050	32751-22770	COLLAR	1				0.173	0.3806
060	32420-67662	COLLAR THRUST	1				0.005	0.011
070	30420-74310	COLLAR THRUST	1				0.015	0.033
080	37800-43870	BOLT	8				0.026	0.0572
090	34076-62700	GEAR-SHAFT	1				1.81	3.982
100	35260-23252	NUT	1				0.04	0.088
110	34070-22770	CASE	1	≤71159			0	0
110	34070-22772	CASE	1	≥71160	↔		0.475	1.045
120	38240-22140	BEARING TAPER-ROLLER	1				0	0
120	T0330-22200	BEARING TAPER-ROLLER	1		«		0.575	1.265
130	01133-51040	BOLT	3				0.03	0.066
140	34070-22860	SHIM	2			0.5mm	0.015	0.033
140	34070-22870	SHIM	4			0.2mm	0.004	0.0088
140	34070-22880	SHIM	2			0.1mm	0.005	0.011
150	34070-22780	COVER BEARING	1				0.21	0.462
160	32751-22740	BEARING ROLLER	1				0.4	0.88
170	34076-99340	ASSY GEAR BEVEL	1			8-39T	5.5	12.1

REAR DIFFERENTIAL

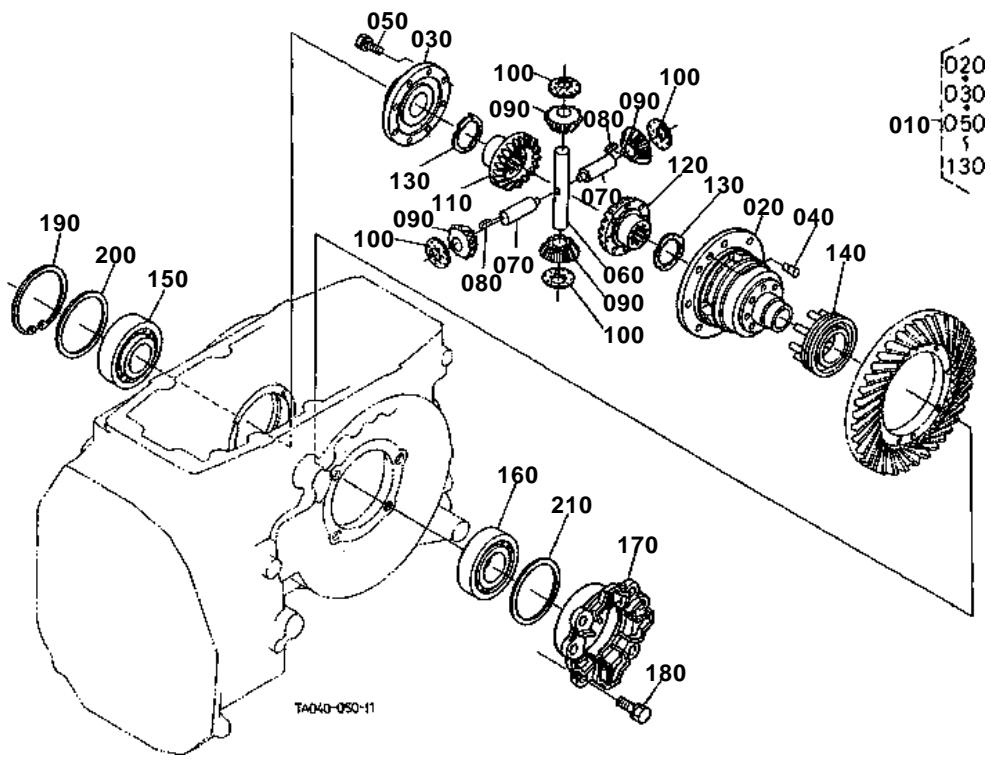

010 31351-2610-0

020 38240-2651-4

030 38240-2652-3

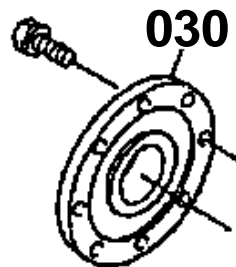
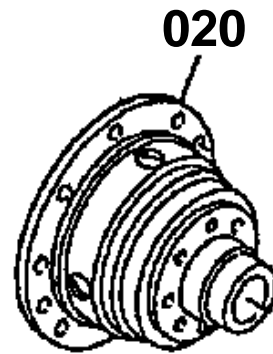
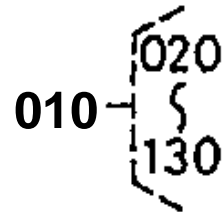

32751-822-10



REAR DIFFERENTIAL

↔ Interchangeable; ≠ not interchangeable; ← new for old; → old for new

REF.No	Part No.	Description	Q'ty	S.No.	I/C	REMARKS	Weight (kgf)	Weight (lb)
010	31351-26100	ASSY DIFFERENTIAL	1				6.8	14.96
010	3A011-32204	ASSY DIFFERENTIAL	1		«		6.2	13.64
020	38240-26514	CASE DIFFERENTIAL	1				0	0
020	3A011-32710	CASE DIFFERENTIAL	1		«		3.35	7.37
030	38240-26523	COVER DIFF.CASE	1				0	0
030	3A011-32044	COVER DIFF CASE	1		«		0.795	1.749
040	37300-28170	PIN STRAIGHT	2				0.025	0.055
050	01133-51025	BOLT	8				0.023	0.0506
060	35430-26340	SHAFT DIFF.PINION	1				0.31	0.682
070	35430-26330	SHAFT DIFF.PINION	2				0.136	0.2992
080	31220-26280	KEY FEATHER	2				0.005	0.011
090	35430-26350	PINION DIFF.	4				0.16	0.352
100	31351-26390	WASHER DIFF.PINION	4				0.012	0.0264
110	37300-26430	GEAR DIFF.SIDE RH	1				0.475	1.045
120	37300-26440	GEAR DIFF.SIDE LH	1				0.63	1.386
130	31351-26470	WASHER SIDE GEAR	2			1.5mm	0.01	0.022
130	31351-26480	WASHER SIDE GEAR	2			1.6mm	0.015	0.033
130	31351-26490	WASHER SIDE GEAR	2			1.7mm	0.016	0.0352
130	3A011-32760	COLLAR THRUST	2	≤60658		1.8mm	0.01	0.022
130	3A011-32780	COLLAR THRUST	2	≥60659	↔	2.0mm	0.01	0.022
140	31351-26610	SHIFTER DIFF.LOCK	1				0.43	0.946
140	37300-26610	SHIFTER DIFF.LOCK	1		«		0.46	1.012
150	08711-32011	BEARING TAPER-ROLLER	1	≤73062			0.538	1.1836
150	T0330-26450	BEARING TAPER-ROLLER	1	≥73063	↔		0.545	1.199
160	08711-30209	BEARING TAPER-ROLLER	1				0.458	1.0076
170	34070-28360	SUPPORT DIFF.	1				0.405	0.891
180	01133-51025	BOLT	4				0.023	0.0506
190	04611-00900	CIR CLIP INTERNAL	1				0.037	0.0814
200	37410-16810	SHIM DIFFERENTIAL	1			0.4mm	0.01	0.022
200	37410-16820	SHIM DIFFERENTIAL	1			0.5mm	0.01	0.022
200	37410-16830	SHIM DIFFERENTIAL	1			0.6mm	0.01	0.022
200	37410-16840	SHIM DIFFERENTIAL	1			0.7mm	0.01	0.022
200	37410-16850	SHIM DIFFERENTIAL	1			0.8mm	0.008	0.0176
200	37410-16860	SHIM DIFFERENTIAL	1			0.9mm	0.009	0.0198
200	37410-16870	SHIM DIFFERENTIAL	1			1.0mm	0.01	0.022
200	37410-16880	SHIM DIFFERENTIAL	1			1.2mm	0.011	0.0242
200	37410-16890	SHIM DIFFERENTIAL	1			1.4mm	0.015	0.033
210	34070-28210	SHIM	1			0.4mm	0.01	0.022
210	34070-28230	SHIM	1			0.6mm	0.015	0.033
210	34070-28250	SHIM	1			0.8mm	0.015	0.033
210	34070-28270	SHIM	1			1.0mm	0.015	0.033
210	34070-28290	SHIM	1			1.2mm	0.02	0.044
210	34070-28310	SHIM	1			1.6mm	0.025	0.055

DEFFERENTIAL LOCK SHIFT FORK

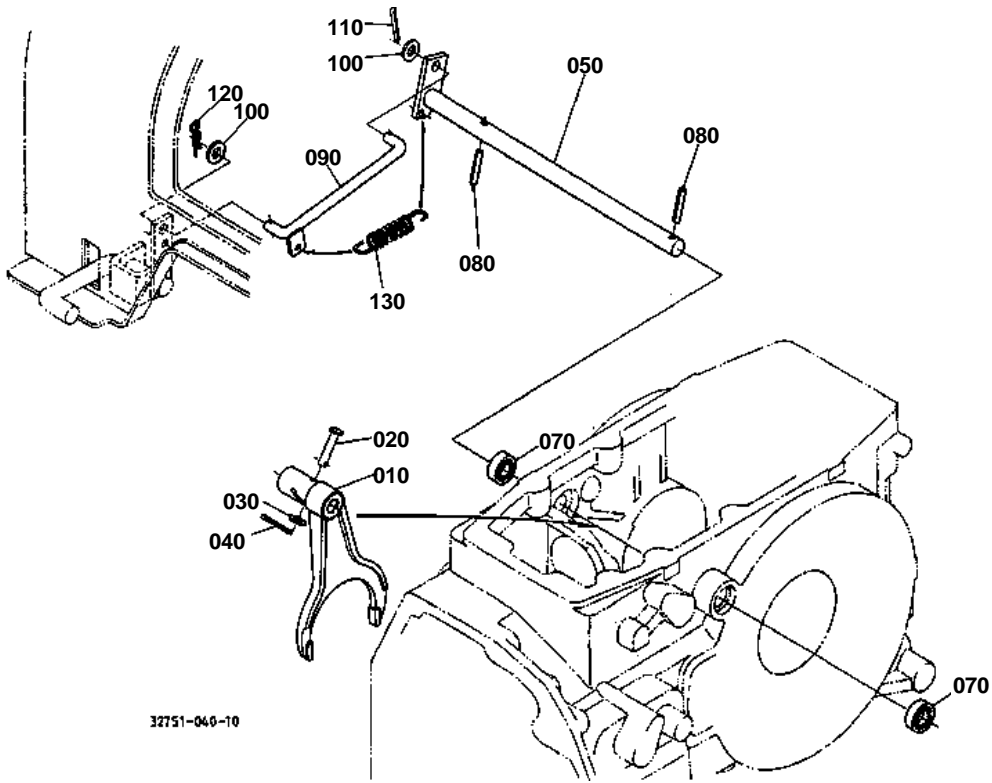



DIFFERENTIAL LOCK SHIFT FORK

↔ Interchangeable; ≠ not interchangeable; ← new for old; → old for new

REF.No	Part No.	Description	Q'ty	S.No.	I/C	REMARKS	Weight (kgf)	Weight (lb)
010	31351-26630	FORK DIFF.LOCK SHIFT	1	<=72428			0	0
010	31351-26632	FORK DIFF.LOCK SHIFT	1	>=72429	-		0.465	1.023
020	31351-26620	PIN JOINT	1				0.008	0.0176
030	04013-60060	WASHER PLAIN	1				0.001	0.0022
040	05511-50212	PIN SPLIT	1				0.001	0.0022
050	34070-28402	SHAFT FORK	1				0.545	1.199
060	99999-99999	BLANK	0				0	0
070	09500-16287	SEAL OIL	2				0.01	0.022
080	05411-00635	PIN SPRING	2				0.005	0.011
090	T0070-28414	ROD DIFF.LOCK	1				0.08	0.176
100	04012-50080	WASHER PLAIN	2				0.001	0.0022
110	05511-50218	PIN SPLIT	1				0.001	0.0022
120	05515-50800	PIN SNAP	1				0	0
130	37150-15840	SPRING	1				0.06	0.132

REAR AXLE

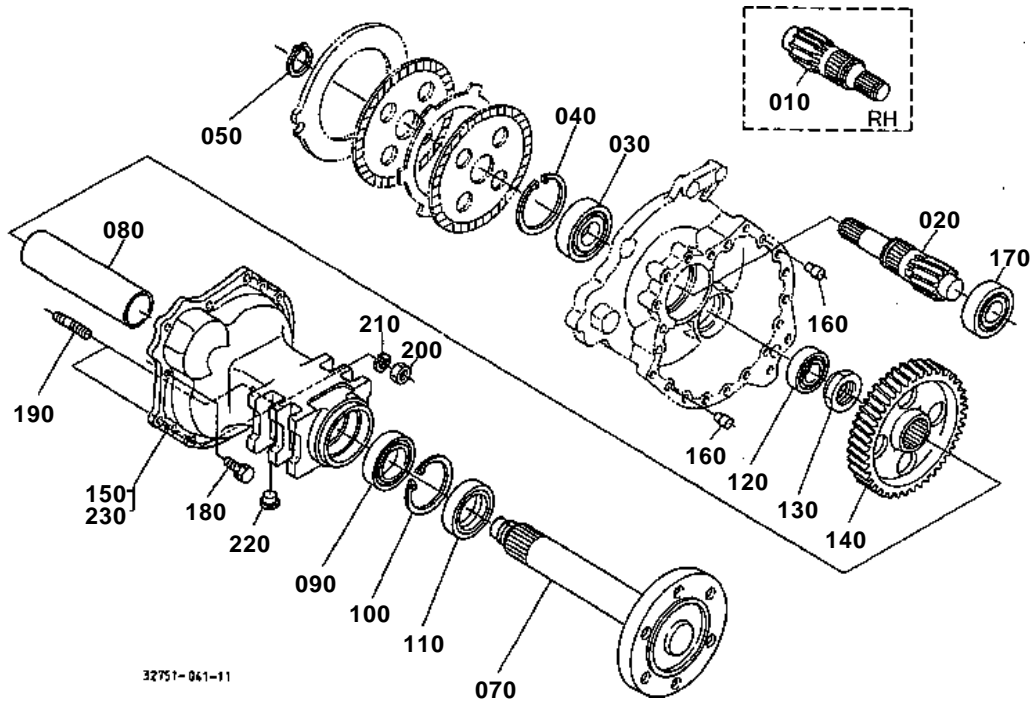

150 32751-2733-0
230 32751-2734-0

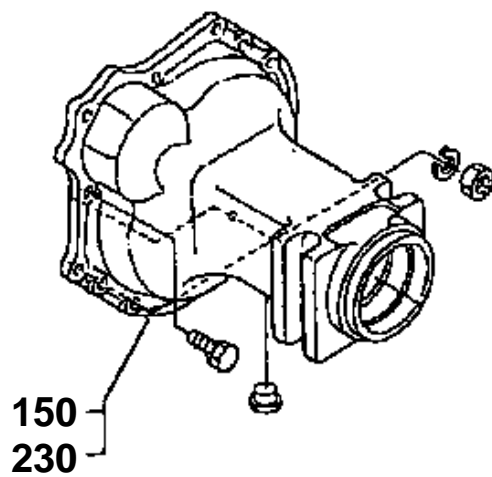

32751-805-10



REAR AXLE

↔ Interchangeable; ≠ not interchangeable; ← new for old; → old for new

REF.No	Part No.	Description	Q'ty	S.No.	I/C	REMARKS	Weight (kgf)	Weight (lb)
010	TA020-26710	SHAFT DIFF.GEAR RH	1			11T	1.92	4.224
020	TA020-26720	SHAFT DIFF.GEAR LH	1			11T	2.2	4.84
030	08101-06309	BEARING BALL	2				0.82	1.804
040	32751-28650	CIR CLIP INTERNAL	2				0.04	0.088
050	04612-00450	CIRCLIP EXTERNAL	2				0.007	0.0154
060	99999-99999	BLANK	0				0	0
070	32420-27113	AXLE REAR	2				10.05	22.11
080	32420-27143	SPACER	2				1.415	3.113
090	08101-06210	BEARING BALL	2				0.45	0.99
100	04611-00900	CIR CLIP INTERNAL	2				0.037	0.0814
110	31351-27560	SEAL OIL	2				0	0
120	36540-41130	BEARING BALL	2	<=60084			0.34	0.748
120	32430-25000	BEARING BALL	2	>=60085	↔		0	0
120	TA140-25000	BEARING BALL	2	>=64670	↔		0.342	0.7524
130	70650-11380	NUT	2				0.11	0.242
140	31341-26833	GEAR	2			53T	4.74	10.428
150	32751-27330	CASE REAR AXLE LH	1	<=60832			0	0
150	32751-27332	CASE REAR AXLE LH	1	>=60833	↔		15.4	33.88
160	32751-27370	PIN STRAIGHT	4				0.006	0.0132
170	08101-06307	BEARING BALL	2				0.455	1.001
180	01133-51035	BOLT	16				0.03	0.066
190	01517-51035	STUD	4				0.028	0.0616
200	02176-50100	NUT	4				0.005	0.011
210	04512-60100	WASHER SPRING	4				0.002	0.0044
220	31220-14290	PLUG	16				0.002	0.0044
230	32751-27340	CASE REAR AXLE RH	1	<=60832			0	0
230	32751-27342	CASE REAR AXLE RH	1	>=60833	↔		15.4	33.88

REAR WHEEL (15-19.5)

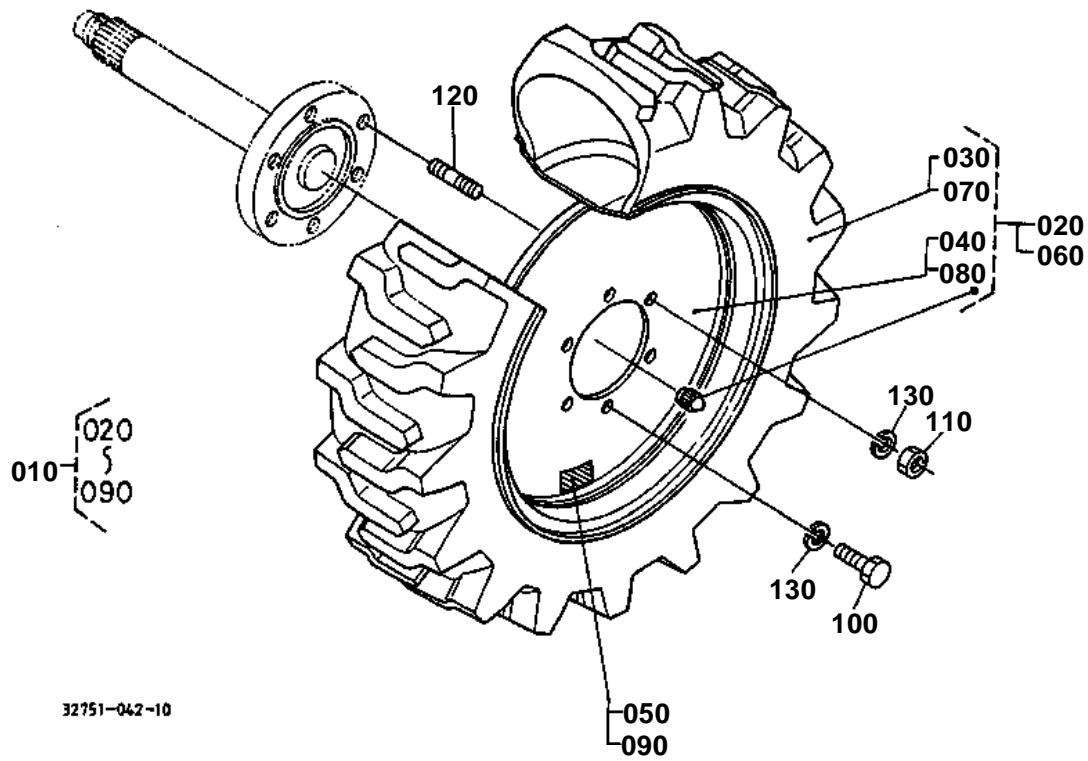

**REAR WHEEL (15-19.5)**

↔ Interchangeable; ≠ not interchangeable; ← new for old; → old for new

REF.No	Part No.	Description	Q'ty	S.No.	I/C	REMARKS	Weight (kgf)	Weight (lb)
010	32751-50800	ASSY REAR WHEEL	1				0	0
020	32751-50810	ASSY TIRE REAR RH	1				0	0
030	32751-50830	TIRE	1				0	0
040	32751-50840	WHEEL	1				0	0
050	32751-50850	LABEL TIRE RH	1				0	0
060	32751-50820	ASSY TIRE REAR LH	1				0	0
070	32751-50830	TIRE	1				0	0
080	32751-50840	WHEEL	1				0	0
090	32751-50860	LABEL TIRE LH	1				0	0
100	01073-51630	BOLT	8				0.079	0.1738
110	02076-50160	NUT	4				0.03	0.066
120	01517-51632	STUD	4				0.076	0.1672
130	04512-60160	WASHER SPRING	12				0.01	0.022

BRAKE

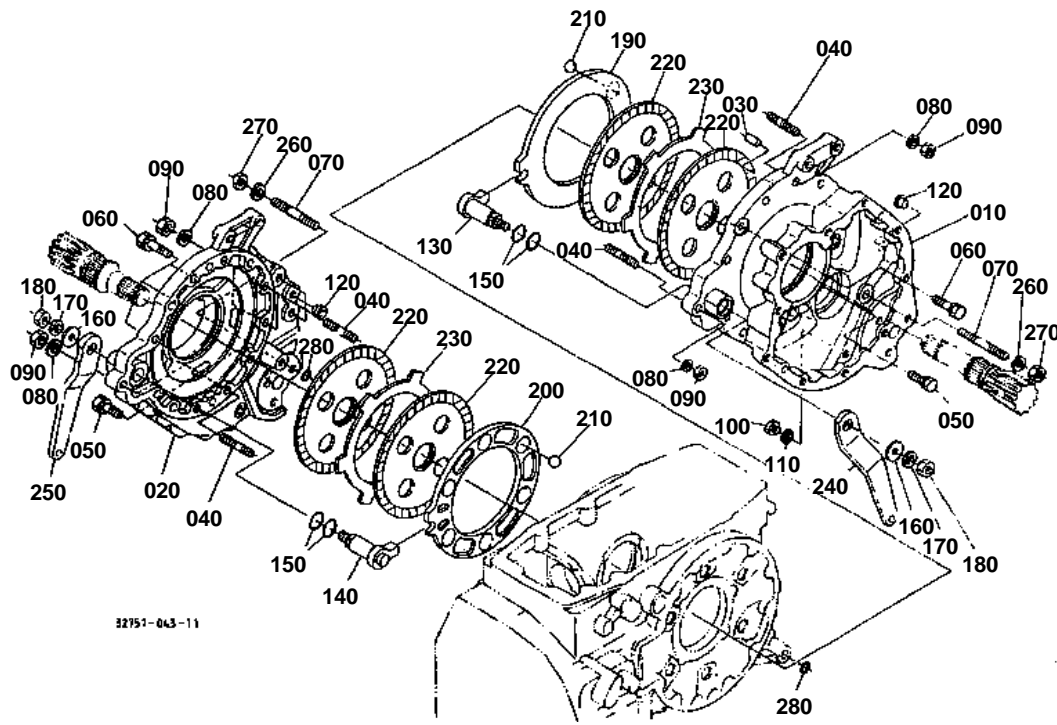

32751-043-11

010 34050-2861-0

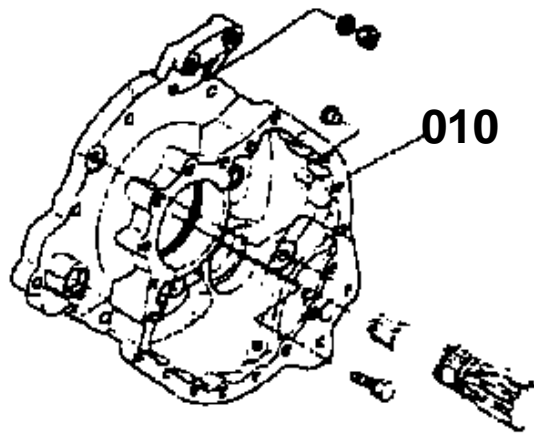

020 34050-2862-0

070 01133-51270

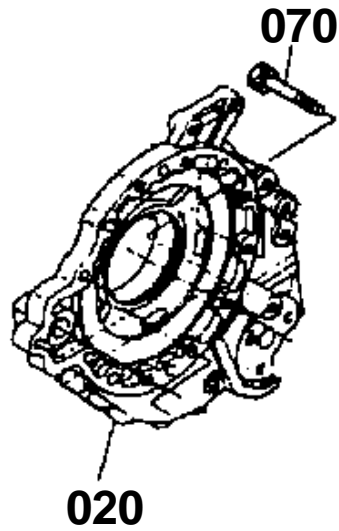

32751-806-10

**BRAKE**

↔ Interchangeable; ≠ not interchangeable; ← new for old; → old for new

REF.No	Part No.	Description	Q'ty	S.No.	I/C	REMARKS	Weight (kgf)	Weight (lb)
010	34050-28610	CASE BRAKE LH	1	<=50868			0	0
010	32751-28610	CASE BRAKE LH	1	>=60001	↗		0	0
010	32751-28612	CASE BRAKE LH	1	>=60879	↗		0	0
010	32751-28613	CASE BRAKE LH	1	>=61970	↗		0	0
010	32751-28614	CASE BRAKE LH	1	>=64670	↗		11.9	26.18
020	34050-28620	CASE BRAKE RH	1	<=50868			0	0
020	32751-28620	CASE BRAKE RH	1	>=60001	↗		0	0
020	32751-28622	CASE BRAKE RH	1	>=60879	↗		0	0
020	32751-28623	CASE BRAKE RH	1	>=61970	↗		0	0
020	32751-28624	CASE BRAKE RH	1	>=64670	↗		11.9	26.18
030	05012-01018	PIN STRAIGHT	4				0.012	0.0264
040	01517-51040	STUD	12				0.03	0.066
050	01133-51035	BOLT	2				0.03	0.066
060	01133-51040	BOLT	12				0.03	0.066
070	01133-51270	BOLT	2	<=50868			0.06	0.132
070	01574-51270	STUD	2	>=60001	↗		0.07	0.154
080	04512-60100	WASHER SPRING	12				0.002	0.0044
090	02176-50100	NUT	12				0.005	0.011
100	06331-35010	PLUG	2				0.012	0.0264
110	04717-01000	WASHER WITH RUBBER	2				0.001	0.0022
120	32210-27580	PLUG	6				0.001	0.0022
130	34070-28715	CAM BRAKE LH	1				0.285	0.627
140	34070-28725	CAM BRAKE RH	1				0.285	0.627
150	04811-00220	O RING	4				0	0
150	04816-00220	O RING	4		↘		0.003	0.0066
160	04015-60120	WASHER PLAIN	2				0.022	0.0484
170	04512-60120	WASHER SPRING	2				0.005	0.011
180	02174-50120	NUT	2				0.01	0.022
190	34070-28770	PLATE BRAKE CAM LH	1				1.11	2.442
200	34070-28780	PLATE BRAKE CAM RH	1				1.14	2.508
210	07715-00805	BALL	12				0.016	0.0352
220	37150-28200	DISK BRAKE MAIN	4				0	0
220	T1060-28200	DISK BRAKE	4		«		0.75	1.65
230	37720-28170	PLATE	2				0.342	0.7524
240	34070-44615	LEVER BRAKE CAM LH	1				0.41	0.902
250	34070-44623	LEVER BRAKE CAM RH	1				0.41	0.902
260	04512-60120	WASHER SPRING	2	>=60001			0.005	0.011
270	02176-50120	NUT	2	>=60001			0.01	0.022
280	04811-10120	O RING	2	>=60001			0.001	0.0022

BRAKE PEDAL

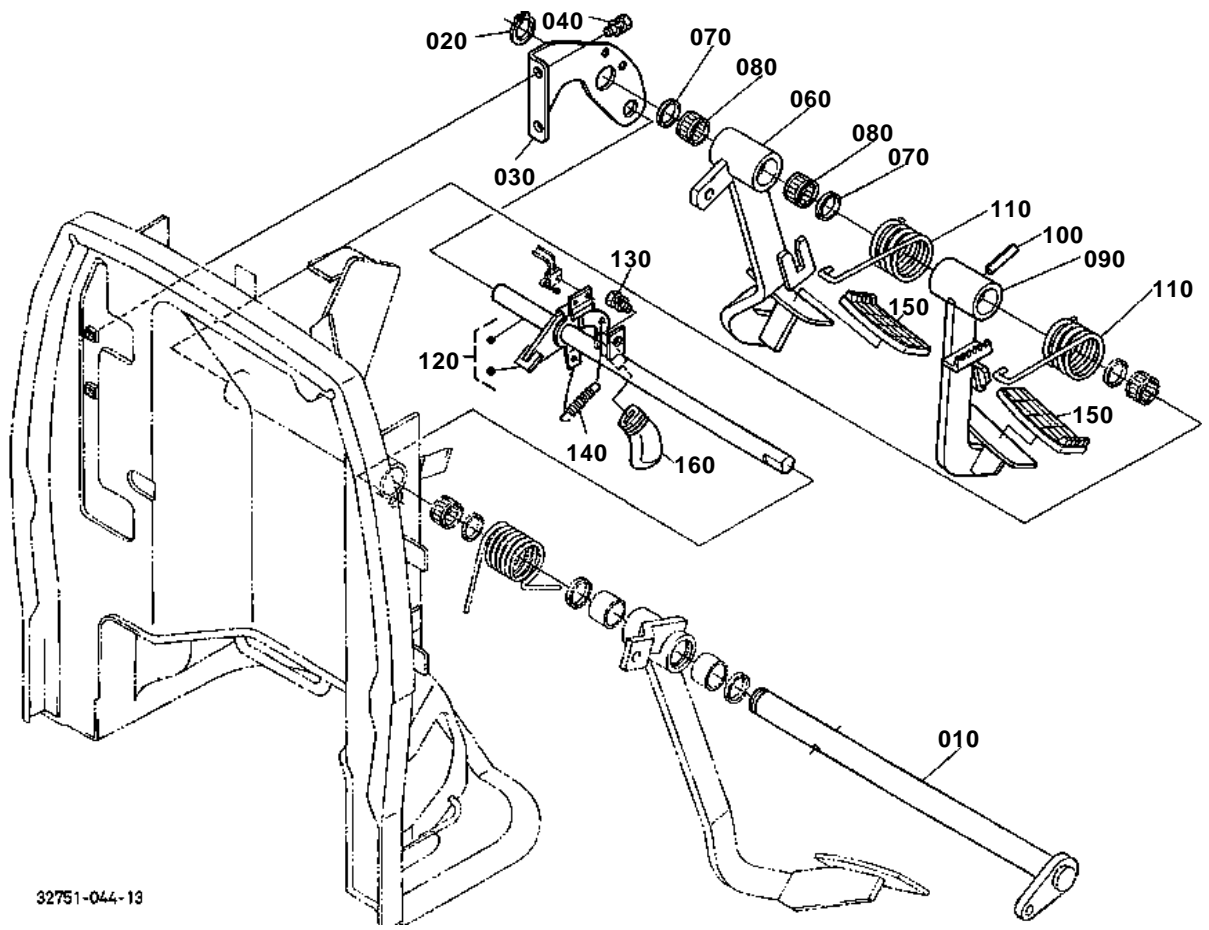

32751-044-13

030 34070-4407-3

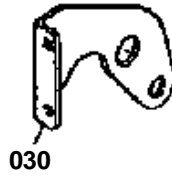

090 TA040-4411-4

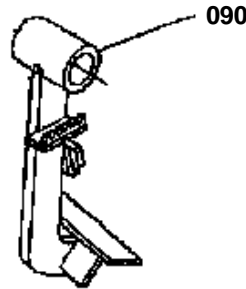

120 TA040-4400-3

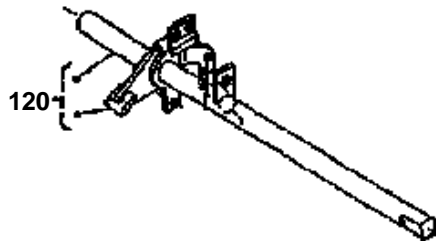

32751-831-10

**BRAKE PEDAL**

NOTE:ORDER BY REF.No.090 and 120 NEW PARTS.

↔ Interchangeable; ≠ not interchangeable; ← new for old; → old for new

REF.No	Part No.	Description	Q'ty	S.No.	I/C	REMARKS	Weight (kgf)	Weight (lb)
010	34070-44010	SHAFT PEDAL	1				1.81	3.982
020	04612-00250	CIRCLIP EXTERNAL	1				0.002	0.0044
030	34070-44072	SUPPORT PEDAL SHAFT	1	<=65112			0	0
030	34070-44073	SUPPORT PEDAL SHAFT	1	>=70047	→		0.255	0.561
030	34070-44074	SUPPORT PEDAL SHAFT	1	>=73503	→		0.255	0.561
040	01123-60816	BOLT	1				0.01	0.022
050	99999-99999	BLANK	0				0	0
060	TA040-44100	ASSY PEDAL BRAKE RH	1	<=60084			0	0
060	TA040-44102	ASSY PEDAL BRAKE RH	1	>=60085	→		1.41	3.102
070	34070-44140	SEAL OIL	2				0.005	0.011
080	34070-44360	BEARING NEEDLE	2				0.012	0.0264
090	TA040-44110	PEDAL BRAKE LH	1	<=60084		NOT SALE SEE NOTE	0	0
090	TA040-44112	PEDAL BRAKE LH	1	>=60085	→	NOT SALE SEE NOTE	0	0
090	TA040-44113	PEDAL BRAKE LH	1	>=60816	→	NOT SALE SEE NOTE	0	0
090	TA040-44114	PEDAL BRAKE LH	1	>=63504	→	NOT SALE SEE NOTE	0	0
090	TA040-44115	PEDAL BRAKE LH	1	>=73231	→	NOT SALE SEE NOTE	1.32	2.904
090	TA040-44116	PEDAL BRAKE LH	1		←		0	0
100	05411-00840	PIN SPRING	1				0.008	0.0176
110	34070-44170	SPRING	2				0.08	0.176
120	TA040-44000	COMP.LOCK PARKING	1	<=60285		NOT SALE SEE NOTE	0	0
120	TA040-44002	COMP.LOCK PARKING	1	>=60286	↑	NOT SALE SEE NOTE	0	0
120	TA040-44003	COMP.LOCK PARKING	1	>=60816	→	NOT SALE SEE NOTE	0.95	2.09
120	TA040-44004	COMP.LOCK PARKING	1	>=73655	↑		0.95	2.09
130	01123-60816	BOLT	1				0.01	0.022
140	36330-83420	SPRING LOCK	1				0.006	0.0132
150	37410-44120	COVER PEDAL	2				0	0
160	TA040-49840	GRIP	1	<=60285			0.03	0.066
160	TA040-49842	GRIP	1	>=60286	↑		0.025	0.055

BRAKE ROD

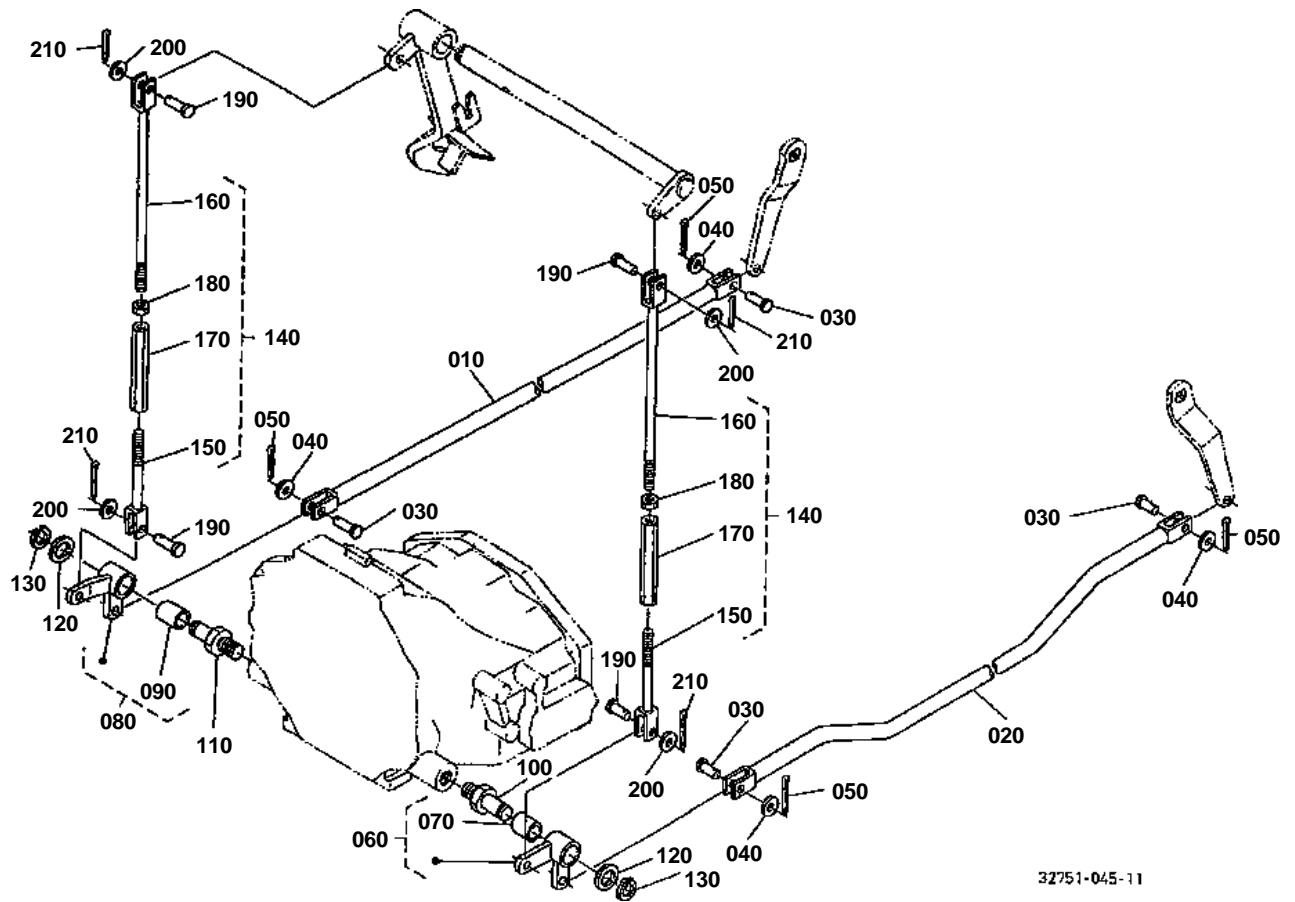

32751-045-11

**BRAKE ROD**

↔ Interchangeable; ≠ not interchangeable; ← new for old; → old for new

REF.No	Part No.	Description	Q'ty	S.No.	I/C	REMARKS	Weight (kgf)	Weight (lb)
010	34070-44640	ROD BRAKE RH	1				1.3	2.86
020	34076-44630	ROD BRAKE LH	1				2.4	5.28
030	05122-51028	PIN JOINT	4				0	0
040	04013-50100	WASHER PLAIN	4				0	0
050	05511-50318	PIN SPLIT	4				0.001	0.0022
060	T0070-44810	ASSY LEVER BRAKE LH	1				0.226	0.4972
070	T0070-44890	BUSH	1				0.028	0.0616
080	T0070-44910	ASSY LEVER BRAKE RH	1				0.215	0.473
090	T0070-44890	BUSH	1				0.028	0.0616
100	T0070-44870	SHAFT BRAKE LH	1				0.23	0.506
110	T0070-44880	SHAFT BRAKE RH	1				0.23	0.506
120	04011-50200	WASHER PLAIN	2				0.015	0.033
130	04612-00200	CIRCLIP EXTERNAL	2				0.001	0.0022
140	34070-44800	ASSY ROD BRAKE	2				0.425	0.935
150	34070-44840	ROD BRAKE	2				0.13	0.286
160	34070-44460	ROD CLUTCH BRAKE	2				0.225	0.495
170	32350-28980	TURNBUCKLE	2				0.124	0.2728
180	02116-50100	NUT	2				0.004	0.0088
190	05122-51028	PIN JOINT	4				0	0
200	04013-50100	WASHER PLAIN	4				0	0
210	05511-50318	PIN SPLIT	4				0.001	0.0022

FRONT AXLE

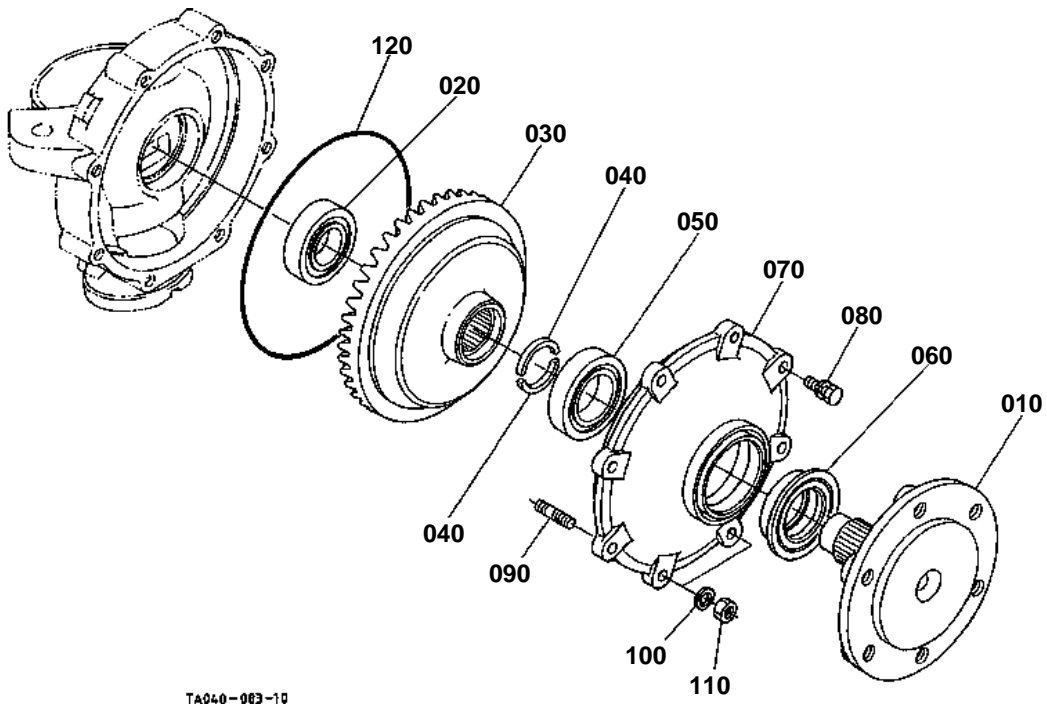

TA040-003-10



FRONT AXLE

↔ Interchangeable; ≠ not interchangeable; ← new for old; → old for new

REF.No	Part No.	Description	Q'ty	S.No.	I/C	REMARKS	Weight (kgf)	Weight (lb)
010	34070-13330	AXLE FRONT	2				3.5	7.7
020	35822-31360	BEARING BALL	2				0.28	0.616
030	34070-13210	GEAR BEVEL	2			42T	5.45	11.99
040	34070-13350	COLLAR	4				0.01	0.022
050	32751-12510	BEARING BALL	2	≤=70594			0	0
050	TA140-13150	BEARING BALL	2	≥=70595	↔		0	0
060	34070-13370	SEAL OIL	2				0.1	0.22
070	TA040-13130	COVER FRONT AXLE	2	≤=70405			0	0
070	TA040-13133	COVER FRONT AXLE	2	≥=70406	↔		3.05	6.71
080	01123-50825	BOLT	12				0.013	0.0286
090	01513-50825	STUD	4				0	0
100	04512-50080	WASHER SPRING	4				0	0
110	02156-50080	NUT	4				0.004	0.0088
120	31353-44130	O RING	2				0.01	0.022

FRONT AXLE CASE

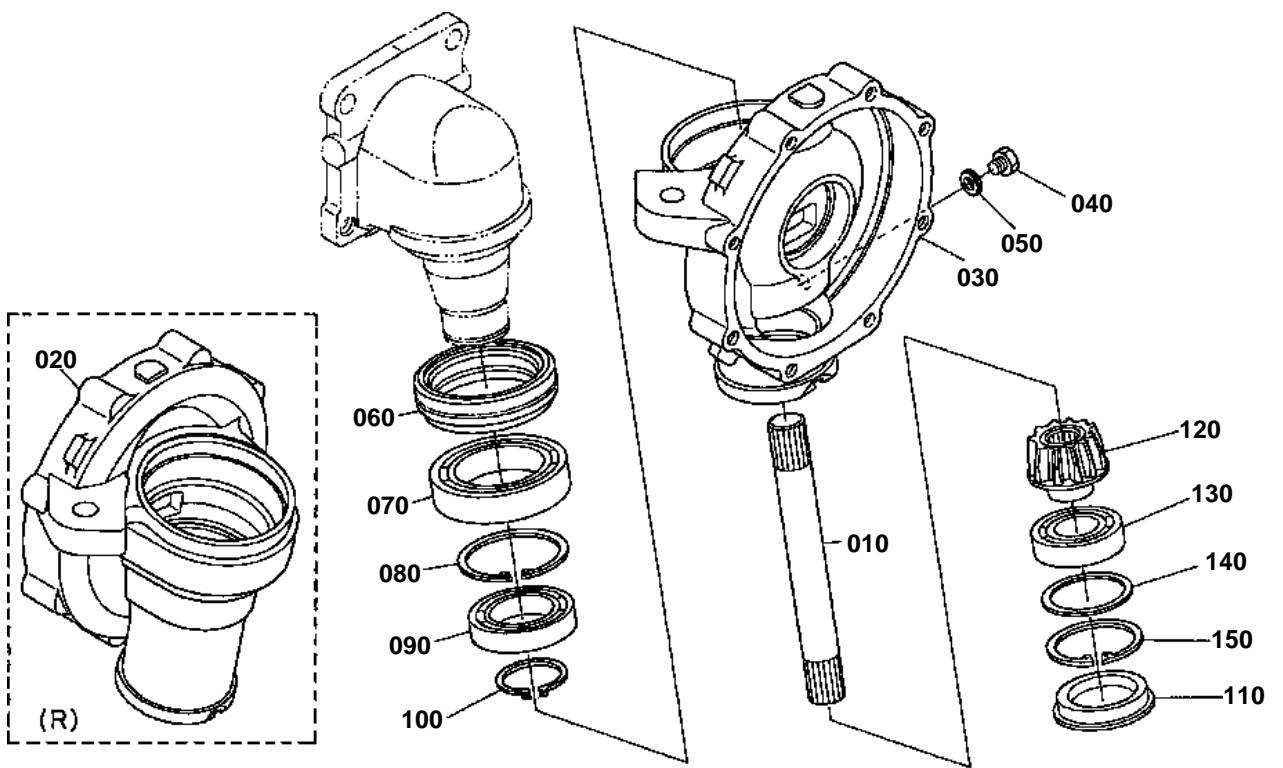

TA040-082-11

060 34550-1404-0

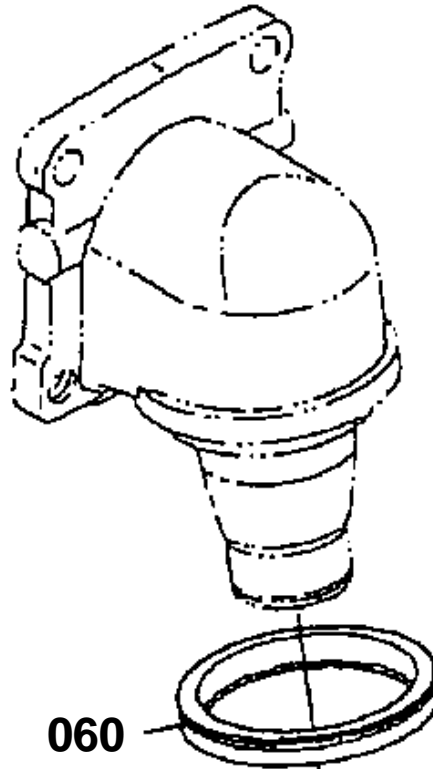

TA040-900-10



FRONT AXLE CASE

↔ Interchangeable; ≠ not interchangeable; ← new for old; → old for new

REF.No	Part No.	Description	Q'ty	S.No.	I/C	REMARKS	Weight (kgf)	Weight (lb)
010	TA040-12720	SHAFT BEVEL GEAR	2				0.73	1.606
020	TA040-13010	CASE FRONT GEAR RH	1	<=60045			0	0
020	TA040-13014	CASE FRONT GEAR RH	1	>=60046	↔		0	0
020	TA040-13015	CASE FRONT GEAR RH	1	>=61970	↔		0	0
020	TA040-13016	CASE FRONT GEAR RH	1	>=63926	↔		8.75	19.25
030	TA040-13020	CASE FRONT GEAR LH	1	<=60045			0	0
030	TA040-13024	CASE FRONT GEAR LH	1	>=60046	↔		0	0
030	TA040-13025	CASE FRONT GEAR LH	1	>=61970	↔		0	0
030	TA040-13026	CASE FRONT GEAR LH	1	>=63926	↔		8.75	19.25
040	06331-35010	PLUG	2				0.012	0.0264
050	04717-01000	WASHER WITH RUBBER	2				0.001	0.0022
060	34550-13040	SEAL OIL	2	<=50835			0	0
060	34550-14040	SEAL OIL	2	>=50836	↔		0.1	0.22
060	TA140-13040	SEAL OIL	2	>=70830	↔		0.155	0.341
070	08101-06014	BEARING BALL	2				0.6	1.32
080	04611-00800	CIR CLIP INTERNAL	2				0.02	0.044
090	08101-06010	BEARING BALL	2				0.262	0.5764
100	04612-00500	CIRCLIP EXTERNAL	2				0.009	0.0198
110	34070-13100	PLUG	2				0.06	0.132
120	TA040-13200	GEAR BEVEL	2			11T	0.48	1.056
130	08101-06207	BEARING BALL	2				0.282	0.6204
140	37410-57160	SHIM	2			1.0mm	0.01	0.022
140	37410-57170	SHIM	2			1.2mm	0.011	0.0242
140	34070-12610	SHIM	2			1.4mm	0.015	0.033
140	34070-12620	SHIM	2			1.6mm	0.015	0.033
140	34070-12630	SHIM	2			1.8mm	0.015	0.033
140	34070-12640	SHIM	2			2.0mm	0.02	0.044
140	34070-12650	SHIM	2			2.2mm	0.02	0.044
150	04611-00720	CIR CLIP INTERNAL	2				0.018	0.0396

DIFFERENTIAL GEAR SHAFT

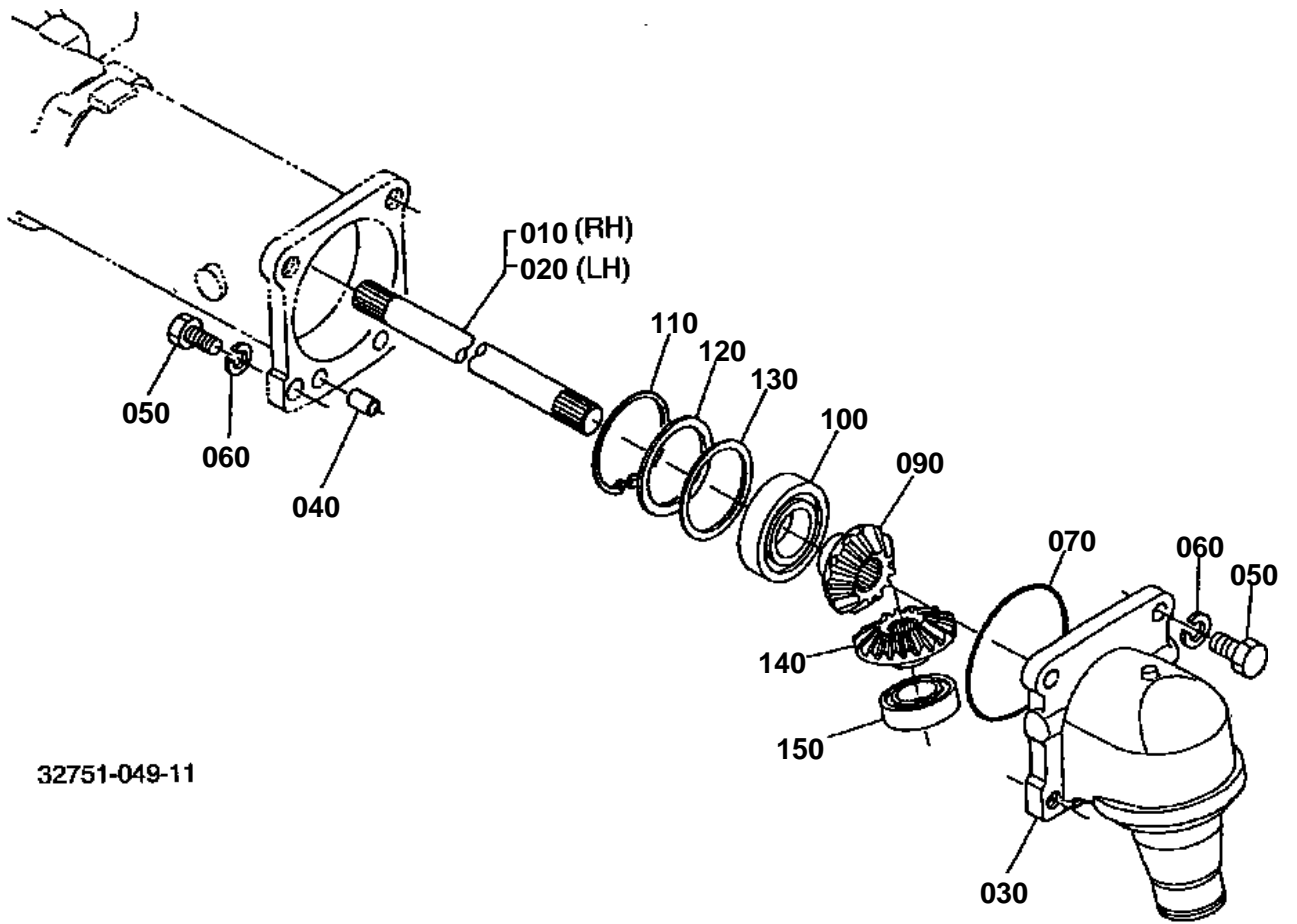

32751-049-11



DIFFERENTIAL GEAR SHAFT

↔ Interchangeable; ≠ not interchangeable; ← new for old; → old for new

REF.No	Part No.	Description	Q'ty	S.No.	I/C	REMARKS	Weight (kgf)	Weight (lb)
010	T0070-12450	SHAFT YOKE LH	1			(RH)	1.77	3.894
020	T0070-12460	SHAFT YOKE RH	1			(LH)	1.1	2.42
030	TA040-12802	CASE BEVEL GEAR	2	<=63925			0	0
030	TA040-12803	CASE BEVEL GEAR	2	>=63926	→		4.4	9.68
040	31353-43880	PIN STRAIGHT	4				0.02	0.044
050	01176-51435	BOLT	8				0.056	0.1232
060	04512-60140	WASHER SPRING	8				0.008	0.0176
070	04811-51050	O RING	2				0.003	0.0066
080	99999-99999	BLANK	0				0	0
090	32751-12520	GEAR BEVEL	2			11T	0.31	0.682
100	08101-06307	BEARING BALL	2				0.455	1.001
110	04611-00800	CIR CLIP INTERNAL	2				0.02	0.044
120	TA040-12700	COLLAR	2	<=50101		2.6mm	0.03	0.066
120	TA040-12702	COLLAR	2	>=50102	→	2.6mm	0.035	0.077
130	31353-43750	SHIM	2			0.4mm	0.008	0.0176
130	31353-43760	SHIM	2			0.6mm	0.01	0.022
130	31353-43770	SHIM	2			0.8mm	0.015	0.033
130	31353-43780	SHIM	2			1.0mm	0.014	0.0308
130	31353-43790	SHIM	2			1.2mm	0.015	0.033
140	32751-12530	GEAR BEVEL	2			16T	0.665	1.463
150	08101-06207	BEARING BALL	2				0.282	0.6204

FRONT DIFFERENTIAL CASE

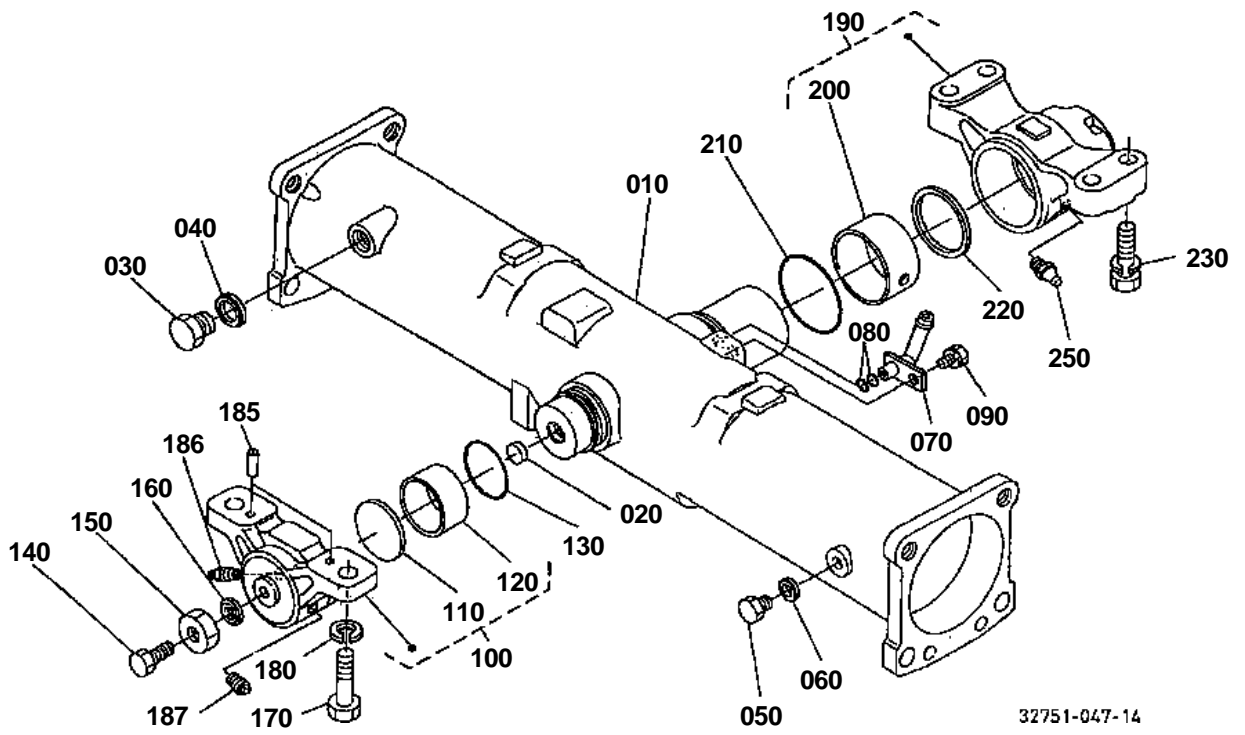

100 TA040-1355-0

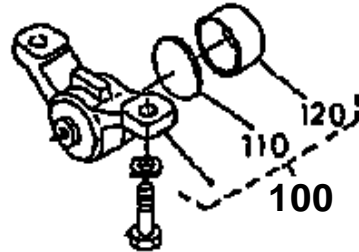

170 01176-51430

180 04512-60140

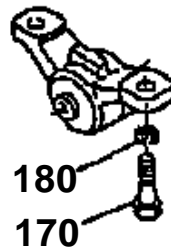

170 TA040-1361-0

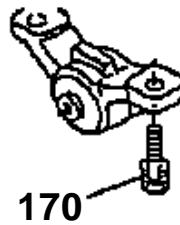

190 32751-1360-0

200 34070-1364-0

230 01176-51245

240 04512-60120

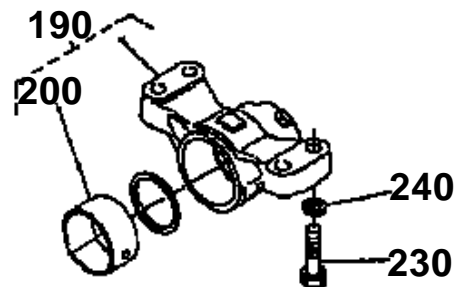

32751-807-12



FRONT DIFFERENTIAL CASE

↔ Interchangeable; ≠ not interchangeable; ← new for old; → old for new

REF.No	Part No.	Description	Q'ty	S.No.	I/C	REMARKS	Weight (kgf)	Weight (lb)
010	32751-12000	CASE FRONT AXLE	1	<=60504		NOT SALE	20	44
010	32751-12005	CASE FRONT AXLE	1	>=60505	1		20	44
020	31321-38720	PLUG	1				0.005	0.011
030	06331-35020	PLUG	1				0.068	0.1496
040	04717-02000	WASHER WITH RUBBER	1				0.004	0.0088
050	06331-35010	PLUG	1				0.012	0.0264
060	04717-01000	WASHER WITH RUBBER	1				0.001	0.0022
070	32751-12910	PIPE BREATHER	1	<=60504			0.025	0.055
070	32751-12912	PIPE BREATHER	1	>=60505	1		0.025	0.055
080	04811-00080	O RING	2				0	0
080	04816-00080	O RING	2		«		0.002	0.0044
090	01123-60814	BOLT	1				0.01	0.022
100	34070-13502	ASSY HOLDER FRONT	1	<=60285			1.52	3.344
100	TA040-13500	ASSY HOLDER FRONT	1	>=60286	↵		0	0
100	TA040-13502	ASSY HOLDER FRONT	1	>=61537	↵		1.6	3.52
100	TA040-13550	ASSY HOLDER FRONT	1	>=62733	1		1.5	3.3
100	TA140-13552	ASSY HOLDER FRONT	1	>=70619	↵		0	0
100	TA140-13553	ASSY HOLDER FRONT	1	>=73601	↵		1.485	3.267
110	37410-56180	COLLAR THRUST	1				0.06	0.132
120	08511-05020	BUSH	1				0.06	0.132
130	04811-00490	O RING	1				0	0
130	04816-00490	O RING	1		«		0.005	0.011
140	31303-44760	BOLT	1				0.025	0.055
150	32751-13550	NUT	1				0.026	0.0572
160	61033-14250	WASHER SEAL	1				0.003	0.0066
170	01176-51430	BOLT	2	<=61536			0.052	0.1144
170	TA040-13610	BOLT	2	>=61537	↵		0.065	0.143
170	TA040-13570	BOLT	1	>=62733	1		0.08	0.176
180	04512-60140	WASHER SPRING	2	<=61536			0.008	0.0176
180	04512-50160	WASHER SPRING	2	>=62733			0	0
185	05012-00818	PIN STRAIGHT	2	>=70619			0.013	0.0286
186	06613-10010	NIPPLE GREASE	1	>=70619			0.006	0.0132
187	06312-10010	PLUG	1	>=70619			0.007	0.0154
190	32751-13600	ASSY HOLDER REAR	1	<=70618			3.2	7.04
190	TA140-13600	ASSY HOLDER REAR	1	>=70619	↵		3.2	7.04
200	34070-13640	BUSH	1	<=70618			0.105	0.231
200	TA140-13640	BUSH	1	>=70619	↵		0.09	0.198
210	04811-50700	O RING	1				0.002	0.0044
220	34070-13620	COLLAR THRUST	1				0.05	0.11
230	01176-51245	BOLT	4	<=72318			0.05	0.11
230	01138-51245	BOLT	4	>=72319	↵		0.051	0.1122
240	04512-60120	WASHER SPRING	4	<=72318			0.005	0.011
250	06613-10010	NIPPLE GREASE	1	>=70619			0.006	0.0132

FRONT DIFFERENTIAL

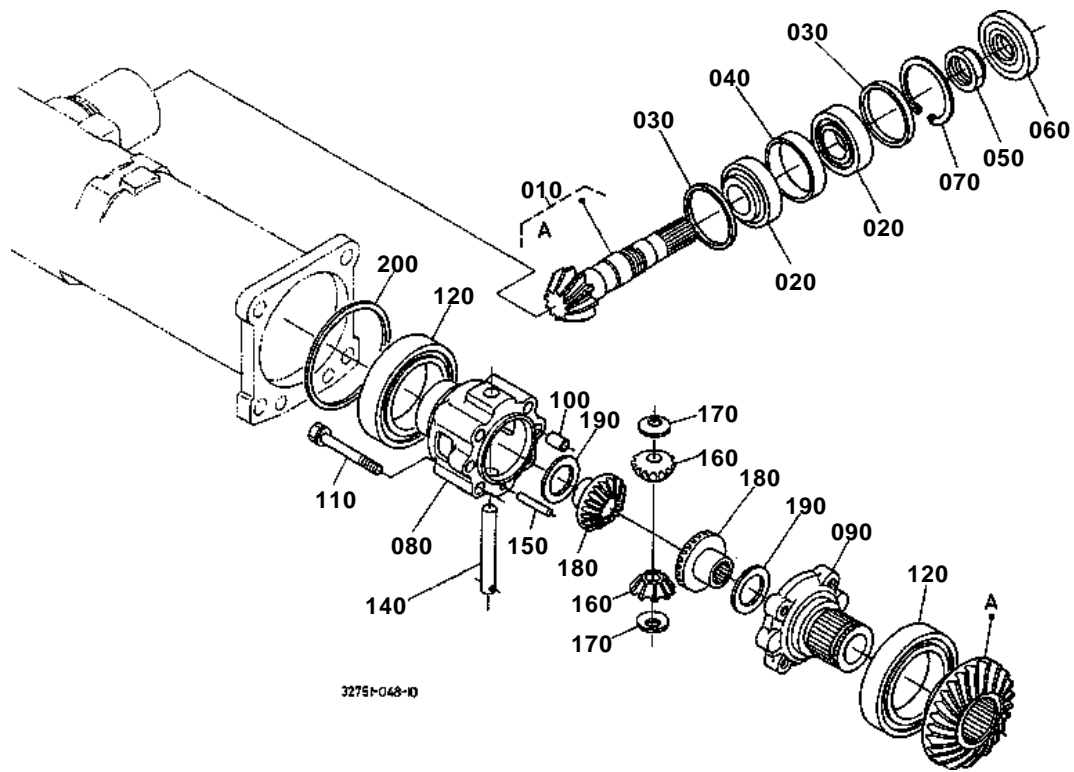

32751-048-10



FRONT DIFFERENTIAL

↔ Interchangeable; ≠ not interchangeable; ← new for old; → old for new

REF.No	Part No.	Description	Q'ty	S.No.	I/C	REMARKS	Weight (kgf)	Weight (lb)
010	34550-12010	ASSY GEAR BEVEL	1	<=50868		9-23T	0	0
010	TA040-12010	ASSY GEAR BEVEL	1	>=60001	-	9-23T	0	0
010	TA040-12013	ASSY GEAR BEVEL	1	>=72273	-	9-23T	1.83	4.026
020	34070-12200	BEARING TAPER-ROLLER	2				0.305	0.671
030	34070-12060	COLLAR	2			5.8mm	0.015	0.033
030	34070-12070	COLLAR	2			5.9mm	0.015	0.033
030	34070-12080	COLLAR	2			6.0mm	0.015	0.033
030	34070-12090	COLLAR	2			6.1mm	0.015	0.033
030	34070-12100	COLLAR	2			6.2mm	0.02	0.044
040	34070-12130	COLLAR	1			9.8mm	0.03	0.066
040	34070-12140	COLLAR	1			9.9mm	0.02	0.044
040	34070-12150	COLLAR	1	<=71159		10.0mm	0	0
040	3A221-43100	COLLAR	1	>=71160	-	10.0mm	0.025	0.055
040	34070-12160	COLLAR	1			10.1mm	0.03	0.066
040	34070-12170	COLLAR	1			10.2mm	0.03	0.066
050	37410-56710	NUT	1				0.03	0.066
060	34070-12220	SEAL OIL	1				0.03	0.066
070	04611-00580	CIR CLIP INTERNAL	1				0.005	0.011
080	34070-12250	CASE DIFF.	1				1.895	4.169
090	32751-12260	CASE DIFF.	1				0.9	1.98
100	05012-01020	PIN STRAIGHT	2				0.013	0.0286
110	01133-51075	BOLT	4				0.03	0.066
120	08101-06212	BEARING BALL	2				0.78	1.716
130	99999-99999	BLANK	0				0	0
140	31353-43330	SHAFT PINION	1	<=73430			0	0
140	31353-43333	SHAFT PINION	1	>=73431	-		0.13	0.286
150	05012-00628	PIN STRAIGHT	1				0.006	0.0132
160	31353-43343	PINION DIFF.	2				0.1	0.22
170	67121-56670	COLLAR PINION THRUST	2				0.006	0.0132
180	31353-43353	GEAR DIFF.SIDE	2				0.19	0.418
190	67211-15160	SHIM	2			1.0mm	0.01	0.022
190	67211-15170	SHIM	2			0.8mm	0.008	0.0176
190	67211-15180	SHIM	2			1.2mm	0.01	0.022
190	31353-43360	SHIM	2			0.6mm	0.01	0.022
190	31353-43370	SHIM	2			0.4mm	0.01	0.022
200	34070-12300	SHIM	1			1.6mm	0.02	0.044
200	34070-12310	SHIM	1			1.8mm	0.03	0.066
200	34070-12320	SHIM	1			2.0mm	0.03	0.066
200	34070-12330	SHIM	1			2.2mm	0.03	0.066
200	34070-12340	SHIM	1			2.4mm	0.035	0.077

PROPELLER SHAFT

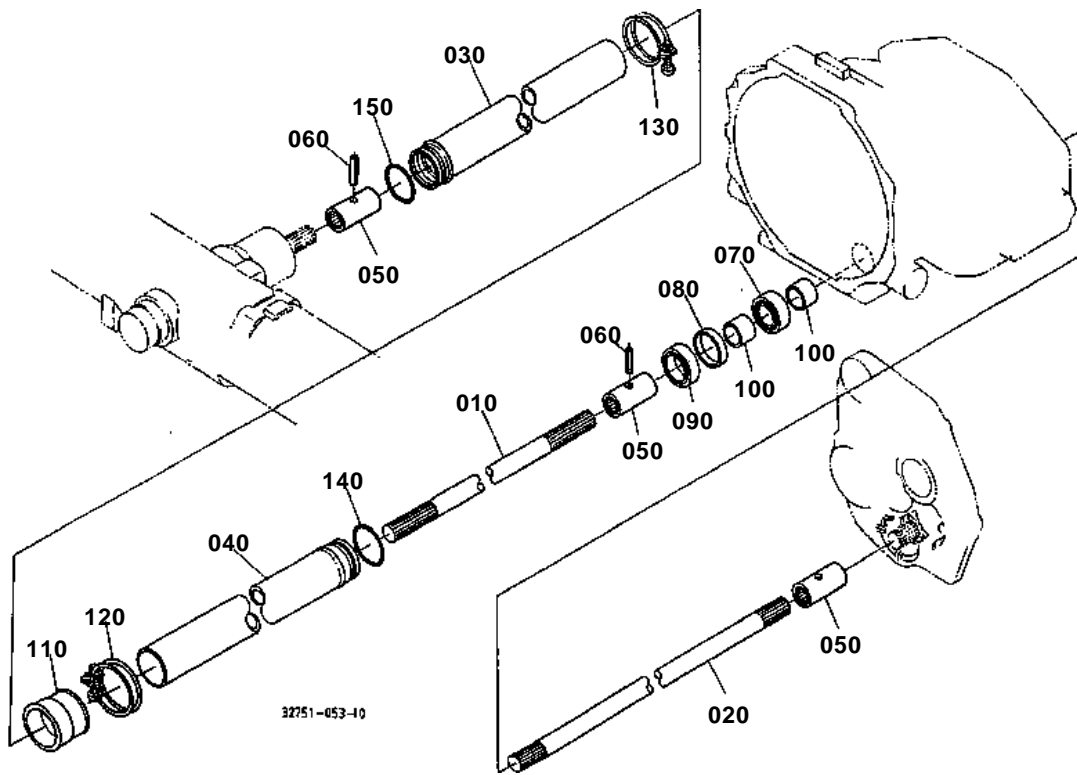



PROPELLER SHAFT

↔ Interchangeable; ≠ not interchangeable; ← new for old; → old for new

REF.No	Part No.	Description	Q'ty	S.No.	I/C	REMARKS	Weight (kgf)	Weight (lb)
010	32751-14630	SHAFT PROPELLER	1				1.1	2.42
020	32751-14640	SHAFT PROPELLER	1				1.455	3.201
030	34070-14570	COVER SHAFT FRONT	1				0.375	0.825
040	34070-14580	COVER SHAFT REAR	1				0.365	0.803
050	T0070-14710	COUPLING	3				0.16	0.352
060	05411-00430	PIN SPRING	2				0.002	0.0044
070	08101-06904	BEARING BALL	1				0.02	0.044
080	34070-14650	COLLAR	1				0.01	0.022
090	09500-25388	SEAL OIL	1				0.01	0.022
100	53582-53520	SLEEVE	2				0.015	0.033
110	37410-57630	JOINT PIPE	1				0.035	0.077
120	09318-89047	CLAMP HOSE	1				0.04	0.088
130	09318-89052	CLAMP HOSE	1				0.03	0.066
140	04811-06330	O RING	1				0	0
140	04816-06330	O RING	1			-	0.002	0.0044
150	04811-10360	O RING	1				0.001	0.0022

FRONT WHEEL DRIVE SHAFT

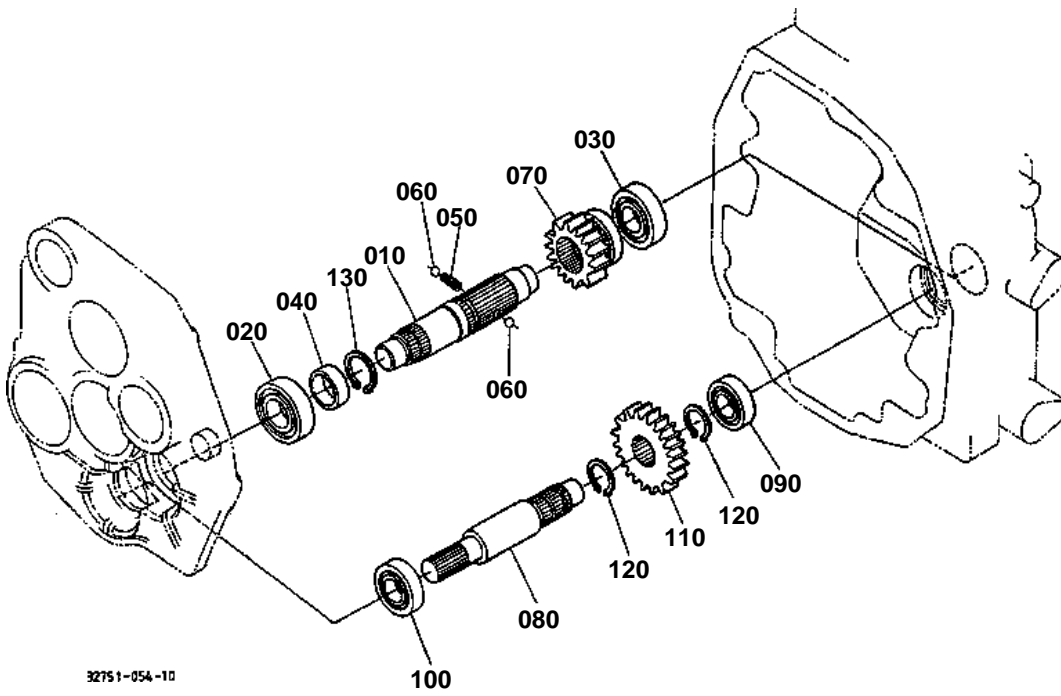



FRONT WHEEL DRIVE SHAFT

↔ Interchangeable; ≠ not interchangeable; ← new for old; → old for new

REF.No	Part No.	Description	Q'ty	S.No.	I/C	REMARKS	Weight (kgf)	Weight (lb)
010	32751-15150	SHAFT 4WD SHIFT GEAR	1				0.94	2.068
020	37410-57190	BEARING BALL	1				0.14	0.308
030	32751-21310	BEARING BALL	1				0.13	0.286
040	32751-15190	COLLAR	1				0.027	0.0594
050	34070-15160	SPRING	1				0.005	0.011
060	07715-00401	BALL	2				0.001	0.0022
070	34070-15170	GEAR 4WD SHIFT	1	<=50868		17T	0	0
070	32751-15170	GEAR 4WD SHIFT	1	>=60001	-	17T	0.47	1.034
080	32751-15210	SHAFT DRIVE	1	<=60189			0	0
080	32751-15212	SHAFT DRIVE	1	>=60190	-		0.67	1.474
090	34070-22560	BEARING BALL	1				0.1	0.22
100	08101-06204	BEARING BALL	1				0.102	0.2244
110	32751-15220	GEAR 4WD	1	<=60189		20T/NOT SALE	0	0
110	32751-15222	GEAR 4WD	1	>=60190	-	20T	0.55	1.21
120	04612-00280	CIRCLIP EXTERNAL	2				0.003	0.0066
130	04612-00320	CIRCLIP EXTERNAL	1				0.004	0.0088

FRONT WHEEL DRIVE LEVER

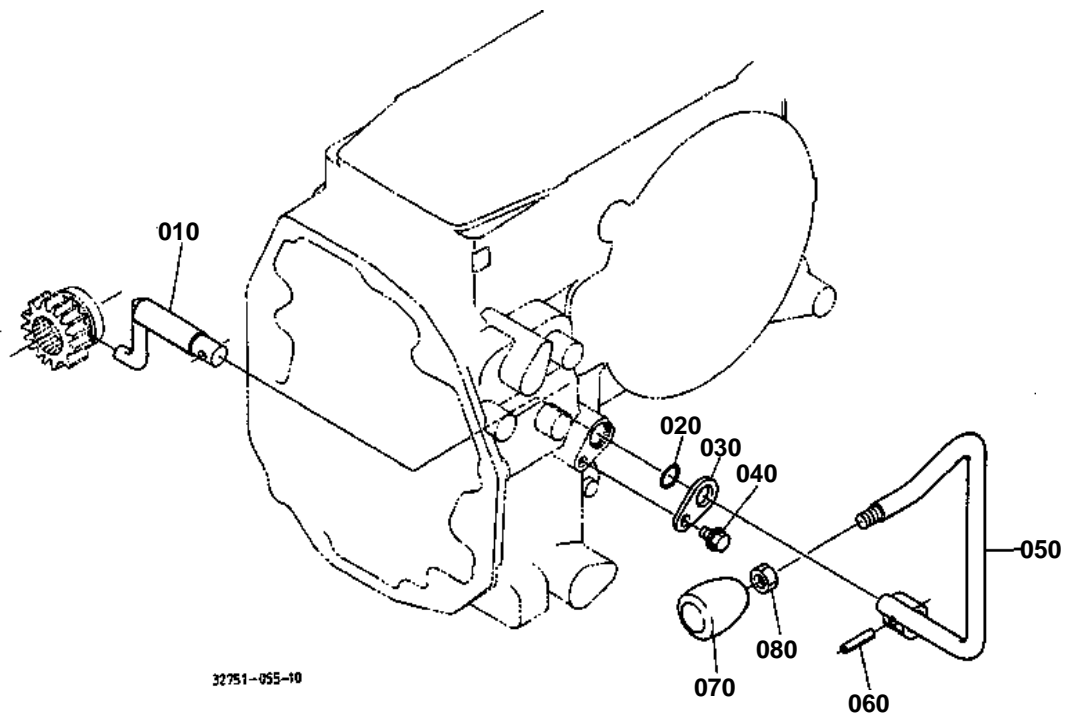



FRONT WHEEL DRIVE LEVER

↔ Interchangeable; ≠ not interchangeable; ← new for old; → old for new

REF.No	Part No.	Description	Q'ty	S.No.	I/C	REMARKS	Weight (kgf)	Weight (lb)
010	34070-15180	LEVER 4WD SHIFT	1				0.27	0.594
020	04811-00200	O RING	1				0	0
020	04816-00200	O RING	1		-		0.003	0.0066
030	34070-24350	STOPPER	1				0.02	0.044
040	01754-50812	BOLT FLANGE	1				0.01	0.022
050	32751-15470	LEVER 4WD CHANGE	1				0.595	1.309
060	05411-00630	PIN SPRING	1				0.004	0.0088
070	TA040-15480	GRIP LEVER	1				0.053	0.1166
080	02116-50100	NUT	1				0.004	0.0088

FRONT WHEEL (27X10.5-15)

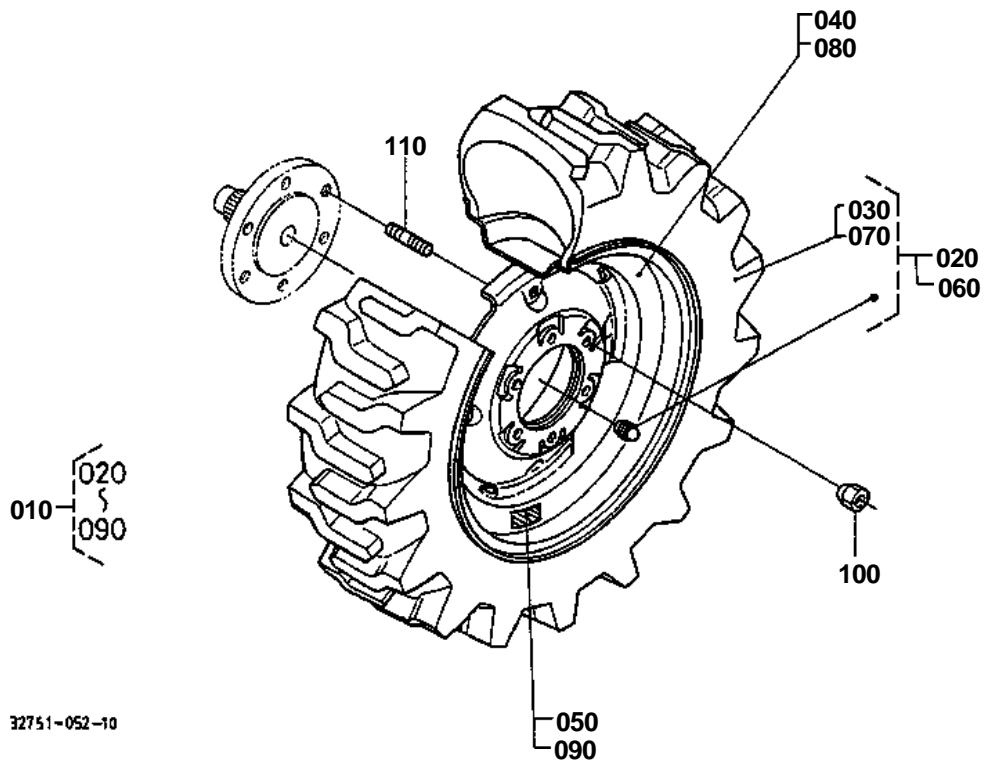



FRONT WHEEL (27X10.5-15)

↔ Interchangeable; ≠ not interchangeable; ← new for old; → old for new

REF.No	Part No.	Description	Q'ty	S.No.	I/C	REMARKS	Weight (kgf)	Weight (lb)
010	32751-50500	ASSY FRONT WHEEL	1				0	0
020	32751-50510	ASSY TIRE REAR RH	1				0	0
030	32751-50530	TIRE	1				0	0
040	32751-50540	WHEEL	1				0	0
050	32751-50550	LABEL TIRE RH	1				0	0
060	32751-50520	ASSY TIRE FRONT LH	1				0	0
070	32751-50530	TIRE	1				0	0
080	32751-50540	WHEEL	1				0	0
090	32751-50560	LABEL TIRE LH	1				0	0
100	35340-11390	NUT	12				0.03	0.066
110	01517-51428	STUD	12				0.05	0.11

FRONT AXLE FRAME

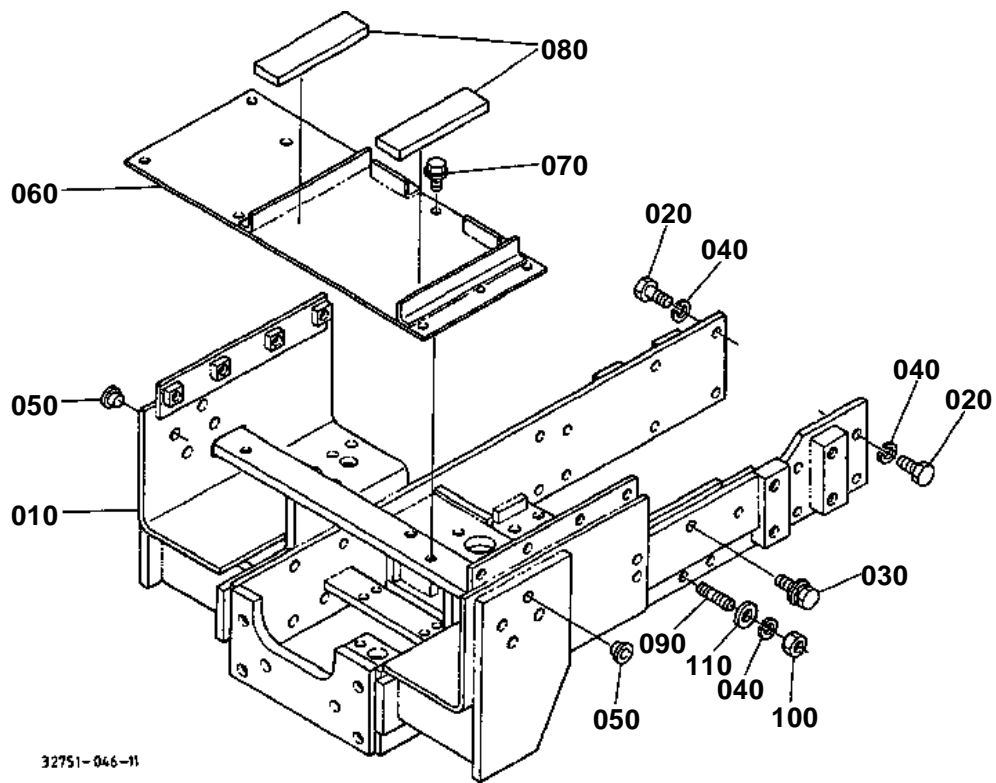

**FRONT AXLE FRAME**

↔ Interchangeable; ≠ not interchangeable; ← new for old; → old for new

REF.No	Part No.	Description	Q'ty	S.No.	I/C	REMARKS	Weight (kgf)	Weight (lb)
010	32751-14010	COMP.FRAME F-AXLE	1	<=50868		NOT SALE	0	0
010	32751-14015	COMP.FRAME F-AXLE	1	>=60001	↔	NOT SALE	59.5	130.9
010	32751-14017	COMP.FRAME F-AXLE	1	>=62733	↔		0	0
010	32751-14018	COMP.FRAME F-AXLE	1	>=70595	↔		59.5	130.9
020	01076-51230	BOLT	10				0	0
030	32751-14960	BOLT	3				0.068	0.1496
040	04512-50120	WASHER SPRING	12				0	0
050	31220-14290	PLUG	8				0.002	0.0044
060	32751-14110	SUPPORT BATTERY	1	<=50835			0	0
060	32751-14113	SUPPORT BATTERY	1	>=50836	↔		2.1	4.62
070	01754-50816	BOLT FLANGE	7	<=50835			0.011	0.0242
070	01754-50816	BOLT FLANGE	6	>=50836			0.011	0.0242
080	32751-14120	SPONGE	2				0.005	0.011
090	32751-14910	STUD	2				0.005	0.011
100	02076-50120	NUT	2	<=60382			0.015	0.033
100	32751-14940	NUT	2	>=60383	↔		0.02	0.044
110	32751-14950	WASHER	2				0.011	0.0242

STEERING LINKAGE

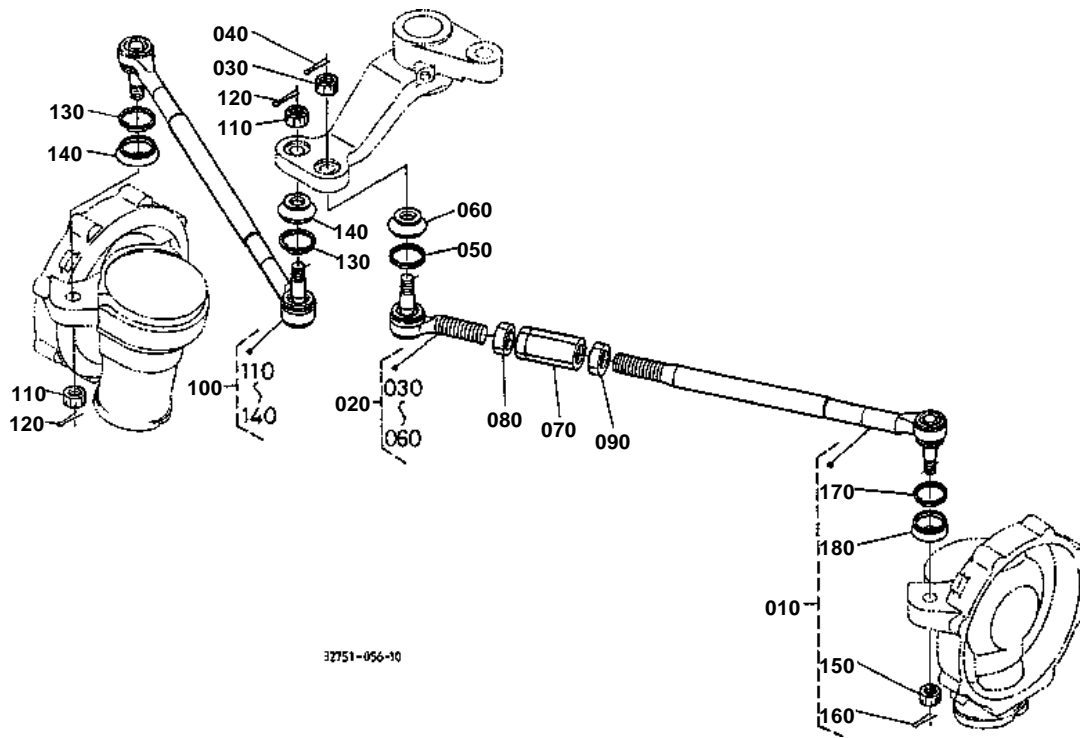



STEERING LINKAGE

↔ Interchangeable; ≠ not interchangeable; ← new for old; → old for new

REF.No	Part No.	Description	Q'ty	S.No.	I/C	REMARKS	Weight (kgf)	Weight (lb)
010	32751-13710	COMP.ROD TIE LH	1				1.5	3.3
020	32580-44750	COMP.END TIE ROD LH	1				0.45	0.99
030	36330-62750	NUT	1				0.022	0.0484
040	05511-50328	PIN SPLIT	1				0.002	0.0044
050	35270-12660	CLIP	1				0.005	0.011
060	32580-44780	COVER DUST	1				0.01	0.022
070	32570-44720	ROD ADJUSTING	1				0.21	0.462
080	38630-44980	NUT	1				0.01	0.022
090	02174-50200	NUT	1				0.04	0.088
100	32751-13760	COMP.ROD TIE RH	1				2.25	4.95
110	36330-62750	NUT	2				0.022	0.0484
120	05511-50328	PIN SPLIT	2				0.002	0.0044
130	35270-12660	CLIP	2				0.005	0.011
140	32580-44780	COVER DUST	2				0.01	0.022
150	36330-62750	NUT	1				0.022	0.0484
160	05511-50328	PIN SPLIT	1				0.002	0.0044
170	35270-12660	CLIP	1				0.005	0.011
180	32580-44780	COVER DUST	1				0.01	0.022

STEERING CYLINDER

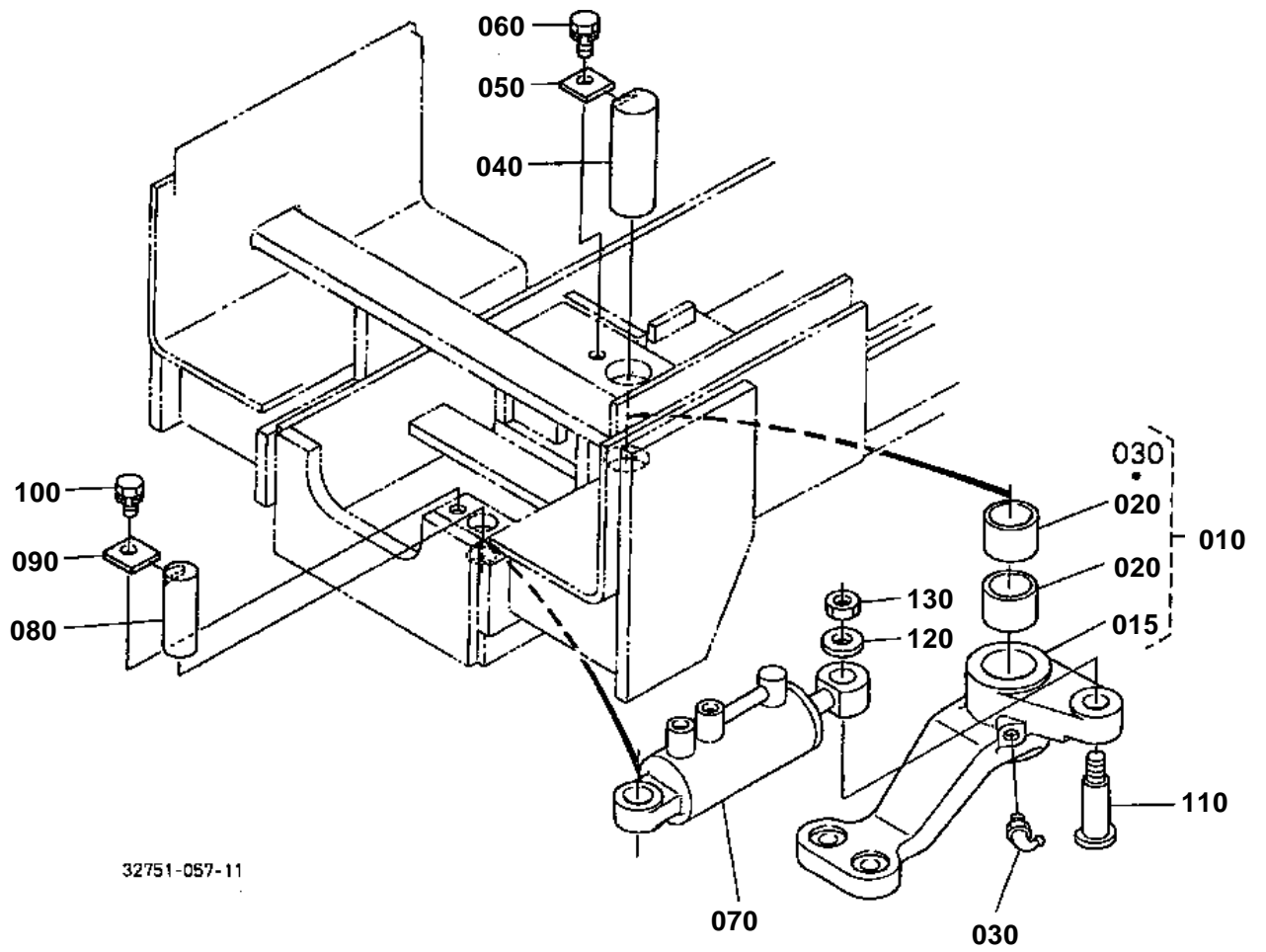



STEERING CYLINDER

↔ Interchangeable; ≠ not interchangeable; ← new for old; → old for new

REF.No	Part No.	Description	Q'ty	S.No.	I/C	REMARKS	Weight (kgf)	Weight (lb)
010	32751-17130	ASSY LEVER STEERING	1			NOT SALE	0	0
015	32751-17142	LEVER STEERING	1				4.4	9.68
020	32530-16930	BUSH	2				0	0
020	52200-22430	BUSH	2		«		0.05	0.11
030	06616-25010	NIPPLE GREASE	1				0.008	0.0176
040	32751-17160	PIN STRG.LEVER	1				1.07	2.354
050	TA040-17180	PLATE ROD END	1				0.031	0.0682
060	01133-51020	BOLT	1				0.02	0.044
070	32751-17210	COMP.CYLINDER HYD.	1				3.05	6.71
080	32590-16630	PIN FULCRUM	1				0.25	0.55
090	TA040-17180	PLATE ROD END	1				0.031	0.0682
100	01133-51020	BOLT	1				0.02	0.044
110	32751-17170	PIN STRG.CYLINDER	1				0.21	0.462
120	32751-17190	COLLAR	1				0.031	0.0682
130	02574-50140	NUT LOCK	1				0.03	0.066

STEERING CYLINDER [COMPONENT PARTS]

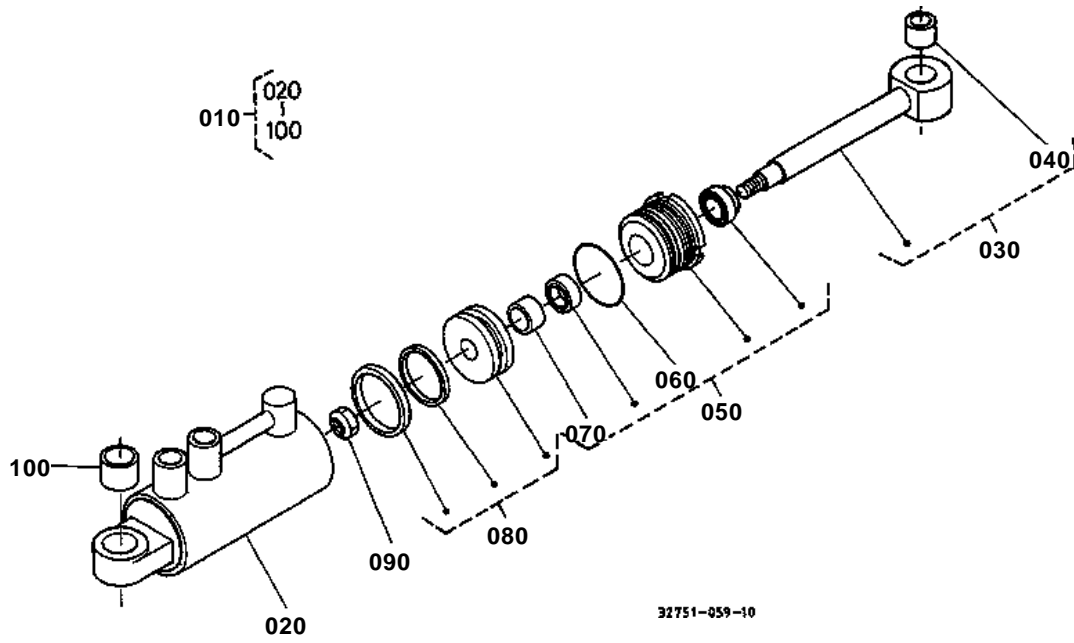



STEERING CYLINDER [COMPONENT PARTS]

↔ Interchangeable; ≠ not interchangeable; ← new for old; → old for new

REF.No	Part No.	Description	Q'ty	S.No.	I/C	REMARKS	Weight (kgf)	Weight (lb)
010	32751-17210	COMP.CYLINDER HYD.	1				3.05	6.71
020	32751-97110	COMP.TUBE CYLINDER	1				1.655	3.641
030	32751-97120	ASSY ROD	1				0.5	1.1
040	08511-02225	BUSH	1				0.02	0.044
050	32751-97130	ASSY CYLINDER HEAD	1				0.48	1.056
060	04810-50500	O RING	1				0	0
060	04817-50500	O RING	1		-		0.003	0.0066
070	08511-01810	BUSH	1				0.005	0.011
080	32751-97140	ASSY PISTON	1				0.28	0.616
090	32751-97150	NUT	1				0.01	0.022
100	08511-02520	BUSH	1				0.02	0.044

STEERING CONTROLLER

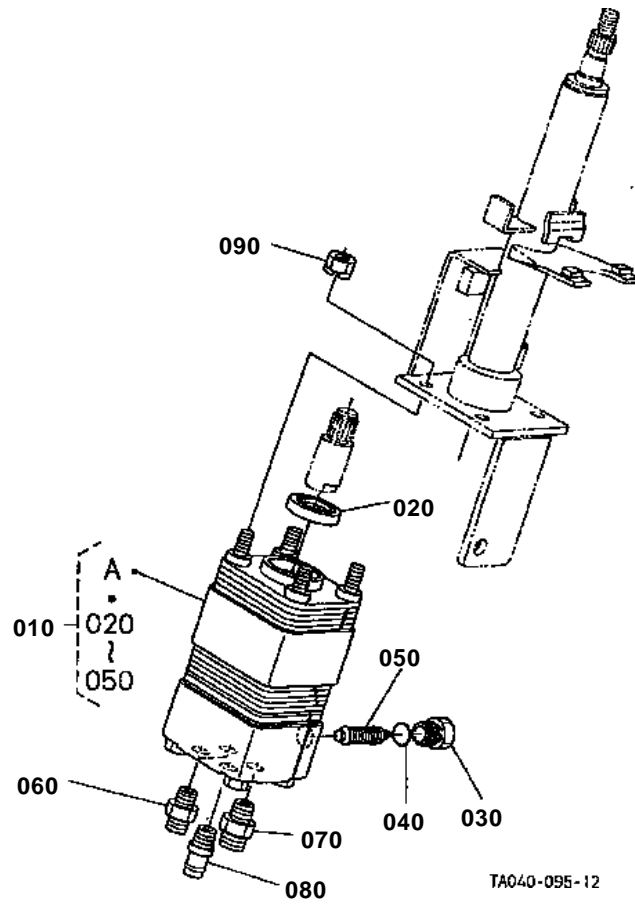

090 02156-50080
100 04512-60080

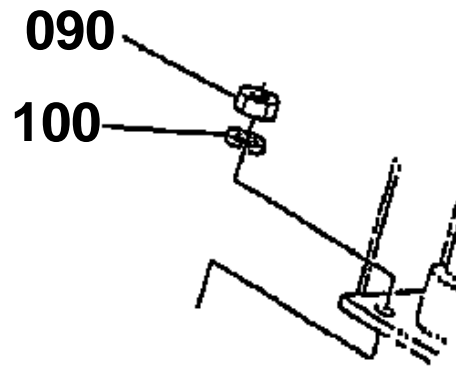

32751-823-10



STEERING CONTROLLER

↔ Interchangeable; ≠ not interchangeable; ← new for old; → old for new

REF.No	Part No.	Description	Q'ty	S.No.	I/C	REMARKS	Weight (kgf)	Weight (lb)
010	TA040-37000	CONTROLLER STEERING	1	<=50868			0	0
010	TA040-37002	CONTROLLER STEERING	1	>=60001	↔		4.8	10.56
020	09500-19387	SEAL OIL	1				0.012	0.0264
030	35070-40840	PLUG	1				0.042	0.0924
040	04810-00150	O RING	1				0	0
040	04817-00150	O RING	1		↔		0.001	0.0022
050	35080-40870	COMP.VALVE RELIEF	1				0.018	0.0396
060	56713-28140	ADAPTER CYLINDER	2				0.03	0.066
070	56713-27220	ADAPTER	1	<=50868			0	0
070	T0120-37200	ADAPTER	1	>=60001	↔		0.055	0.121
070	T0180-37300	JOINT	1	>=67451	®		0.06	0.132
080	50050-27730	JOINT PIPE	1				0	0
080	06111-53022	ADAPTER	1		«		0.05	0.11
090	02156-50080	NUT	4	<=72318			0.004	0.0088
090	16429-92010	NUT	4	>=72319	↔		0.007	0.0154
100	04512-60080	WASHER SPRING	4	<=72318			0.002	0.0044

STEERING HANDLE

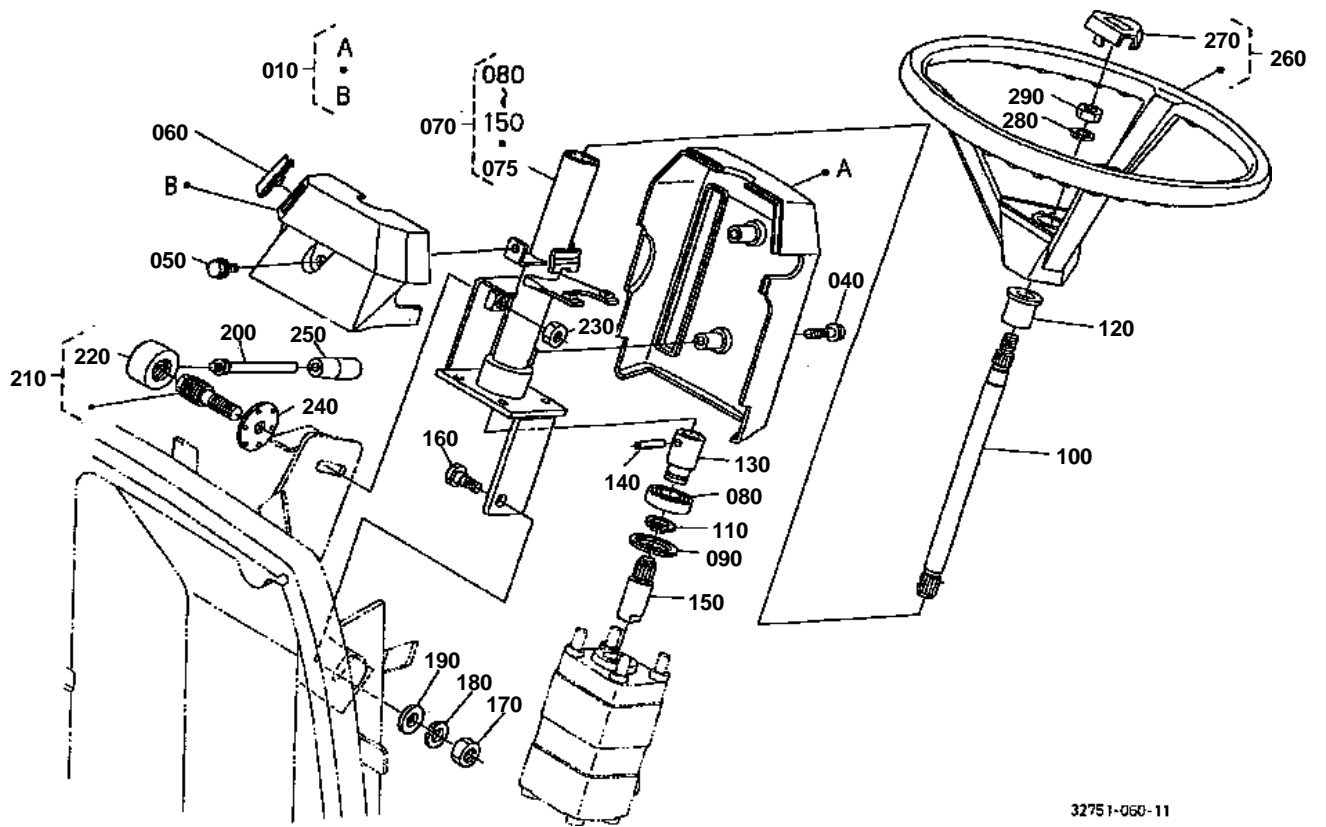

32751-060-11



STEERING HANDLE

↔ Interchangeable; ≠ not interchangeable; ← new for old; → old for new

REF.No	Part No.	Description	Q'ty	S.No.	I/C	REMARKS	Weight (kgf)	Weight (lb)
010	34070-43100	COVER STEERING POST	1				0.255	0.561
020	99999-99999	BLANK	0				0	0
030	99999-99999	BLANK	0				0	0
040	34070-43110	BOLT FLANGE	2				0.02	0.044
050	30400-18870	BOLT FLANGE	1				0.01	0.022
060	34070-43140	COVER HANDLE POST	1				0.005	0.011
070	TA040-43600	ASSY POST STEERING	1				1.8	3.96
075	TA040-43614	POST STEERING	1				1.155	2.541
080	08121-06004	BEARING BALL	1				0.075	0.165
090	04611-00420	CIR CLIP INTERNAL	1				0.006	0.0132
100	TA040-43680	SHAFT JOINT	1				0.4	0.88
110	36919-30040	CIR-CLIP	1				0.001	0.0022
120	37410-41340	BUSH POST	1				0.015	0.033
130	34550-43690	COUPLING STEERING	1				0.103	0.2266
140	05411-00425	PIN SPRING	1				0.001	0.0022
150	35080-40170	SHAFT JOINT	1				0.11	0.242
160	34070-43670	BOLT	1				0.02	0.044
170	02114-50080	NUT	1				0.005	0.011
180	04512-50080	WASHER SPRING	1				0	0
190	04015-50080	WASHER PLAIN	1				0	0
200	34070-43720	LEVER TILT	1				0.065	0.143
210	34550-43750	ASSY SHAFT SCREW	1				0.23	0.506
220	34550-43713	HOLDER TILT LEVER	1			NOT SALE	0.15	0.33
230	02172-50120	NUT	1				0.01	0.022
240	34070-43640	HOLDER TILT	1				0.03	0.066
250	61023-41630	GRIP	1				0.015	0.033
260	31351-16063	ASSY WHEEL STEERING	1				2.4	5.28
270	31351-16082	PAD STEERING	1				0.07	0.154
280	04512-50120	WASHER SPRING	1				0	0
290	02176-50120	NUT	1				0.01	0.022

HYDRAULIC OIL LINE (PS)

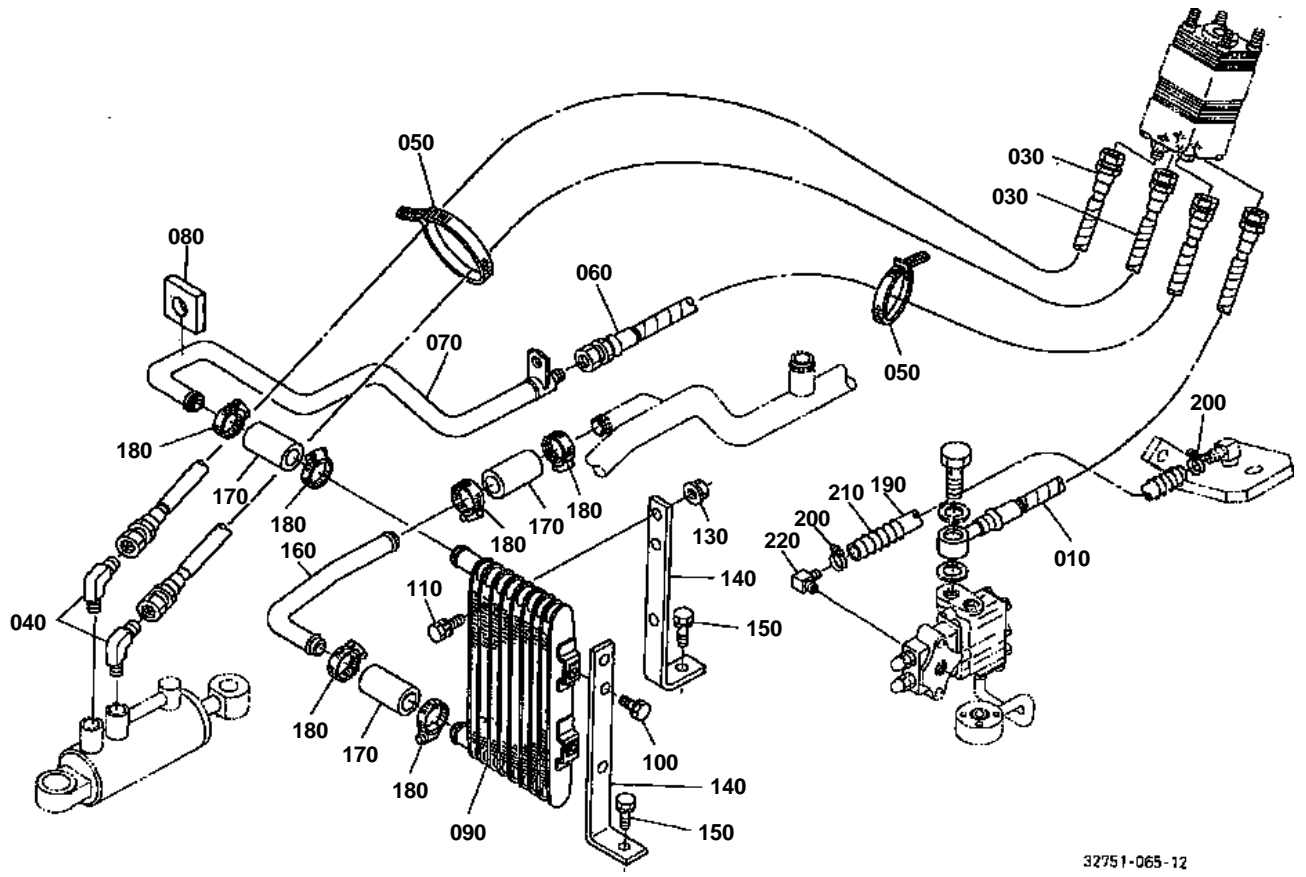

32751-065-12

020 32751-3352-0

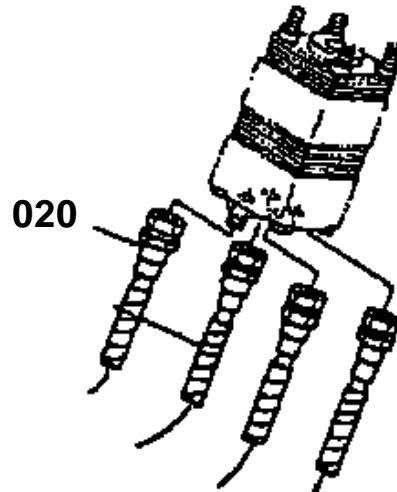

110 01053-50620

120 04512-60060

130 02014-50060

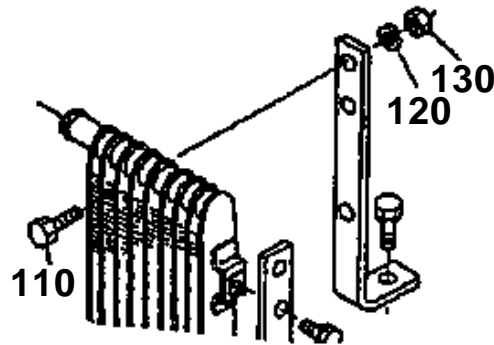

32751-808-11



HYDRAULIC OIL LINE (PS)

↔ Interchangeable; ≠ not interchangeable; ← new for old; → old for new

REF.No	Part No.	Description	Q'ty	S.No.	I/C	REMARKS	Weight (kgf)	Weight (lb)
010	32751-33510	HOSE DELIVERY	1	<=64750			0	0
010	32751-33540	HOSE DELIVERY	1	>=64751	←		0.46	1.012
020	32751-33520	ASSY HOSE POWER STRG	1	<=62457			0.37	0.814
030	32751-33530	ASSY HOSE POWER STRG	1	<=62457			0	0
030	32751-33530	ASSY HOSE POWER STRG	2	>=62458			0	0
030	32751-33520	ASSY HOSE	2		«		0.37	0.814
040	56713-28130	ADAPTER CYLINDER	2				0.052	0.1144
050	55311-41260	BAND CORD	2				0.007	0.0154
060	32751-33560	ASSY HOSE RETURN	1				0.24	0.528
070	32751-33570	COMP.PIPE OIL COOLER	1				0.43	0.946
080	32751-33640	CUSHION	1				0.002	0.0044
090	66419-58720	ASSY COOLER OIL	1				0.68	1.496
100	01023-50616	BOLT	2				0.005	0.011
110	01053-50620	BOLT	2	<=72318			0.006	0.0132
110	01023-50616	BOLT	2	>=72319	←		0.005	0.011
120	04512-60060	WASHER SPRING	2	<=72318			0.001	0.0022
130	02014-50060	NUT	2	<=72318			0.002	0.0044
130	02751-50060	NUT FLANGE	2	>=72319	←		0.005	0.011
140	32751-16530	STAY OIL COOLER	2				0.175	0.385
150	01133-51020	BOLT	2				0.02	0.044
160	32751-33620	PIPE OIL COOLER	1				0.12	0.264
170	66301-36220	HOSE	3				0.055	0.121
180	66204-36230	BAND PIPE	6	<=50801			0.02	0.044
180	67955-36230	CLAMP	6	>=50802	«		0.023	0.0506
190	32751-33590	HOSE REGULATOR VALVE	1				0.125	0.275
200	09318-88180	CLAMP HOSE	2				0.01	0.022
210	31351-45330	SPRING PROTECTOR	1				0.055	0.121
220	34070-36910	JOINT	1				0.07	0.154
220	T1270-36910	JOINT	1		«		0.072	0.1584

GST VALVE

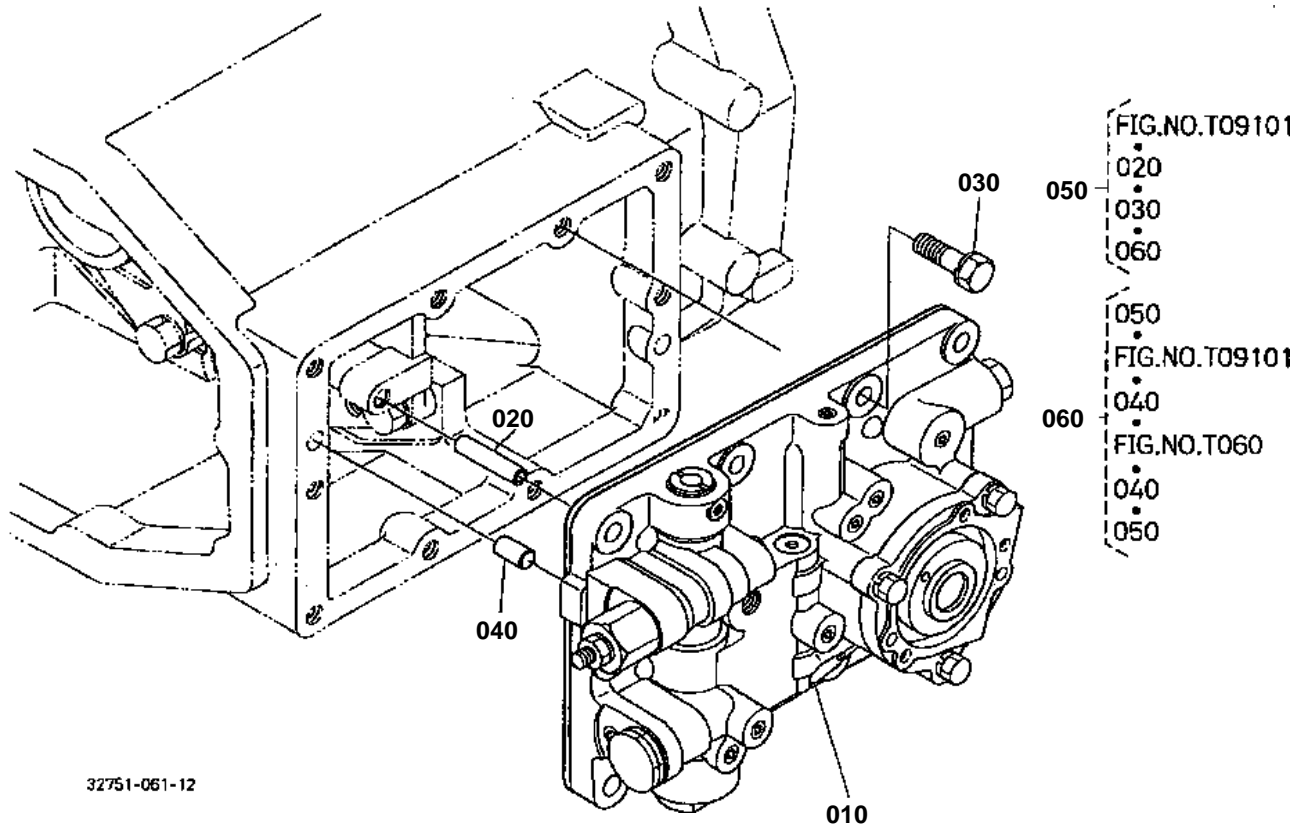



GST VALVE

↔ Interchangeable; ≠ not interchangeable; ← new for old; → old for new

REF.No	Part No.	Description	Q'ty	S.No.	I/C	REMARKS	Weight (kgf)	Weight (lb)
010	TA040-65010	ASSY VALVE GST	1	<=50497		NOT SALE	0	0
010	TA040-65012	ASSY VALVE GST	1	>=50498	-	NOT SALE	0	0
010	TA040-99030	ASSY VALVE GST	1	>=63146	-	NOT SALE	0	0
010	TA040-99034	ASSY VALVE GST	1	>=72643	-		8.45	18.59
020	32751-64990	PIPE HYDRAULIC	1				0.006	0.0132
030	01133-51032	BOLT	10				0.025	0.055
040	05012-01018	PIN STRAIGHT	2				0.012	0.0264
050	34076-99280	ASSY COVER VALVE	1				0.23	0.506
060	34076-99200	ASSY SEAL ROTARY VA.	1				0.3	0.66

GST VALVE [GST TYPE] [COMPONENT PARTS]

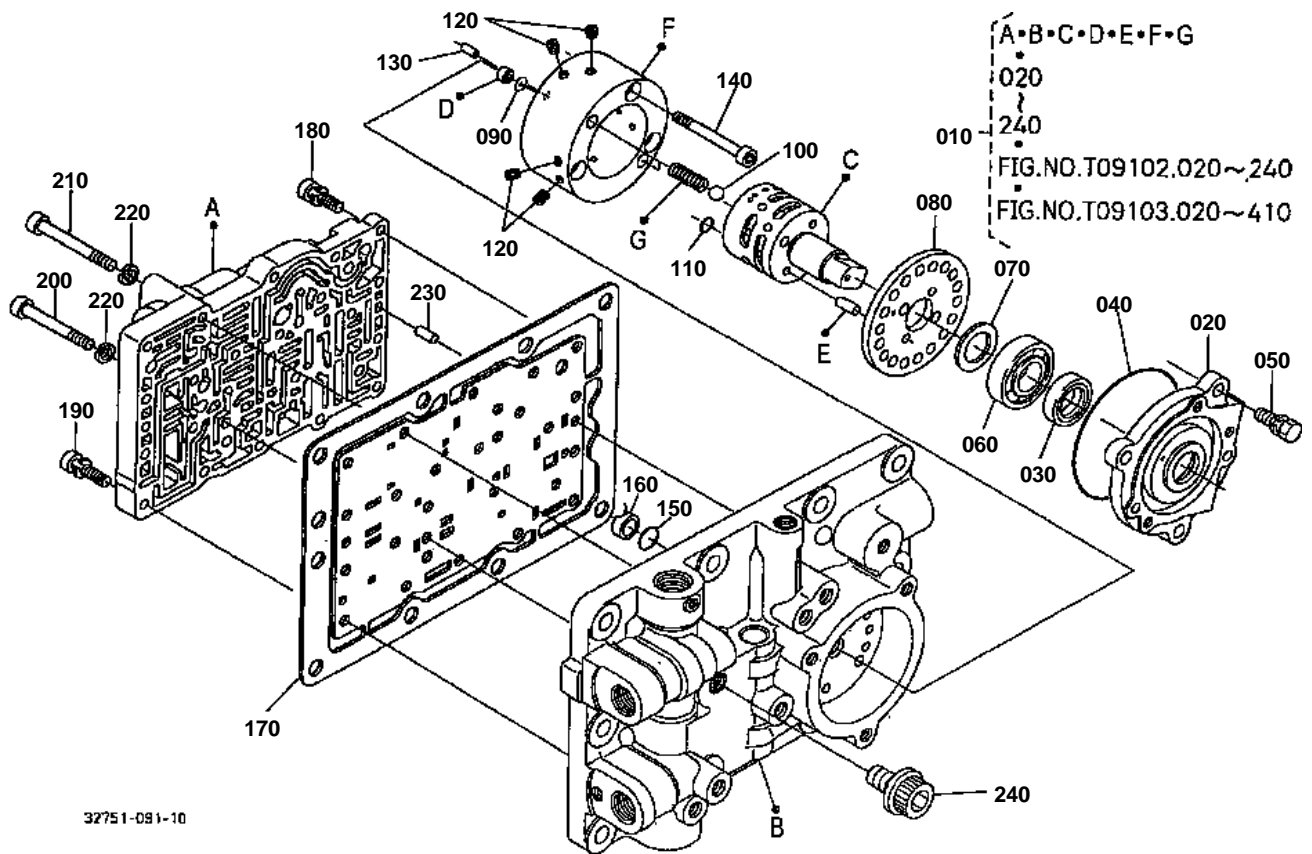

040 34076-6552-0

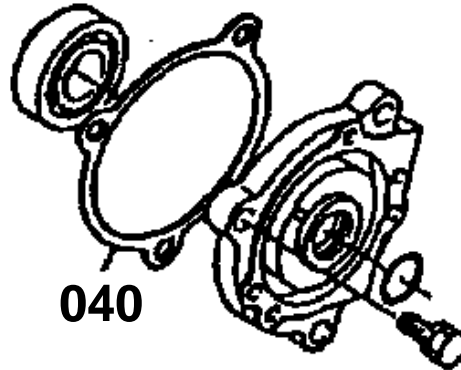

020 34076-6551-2

030 04811-00200

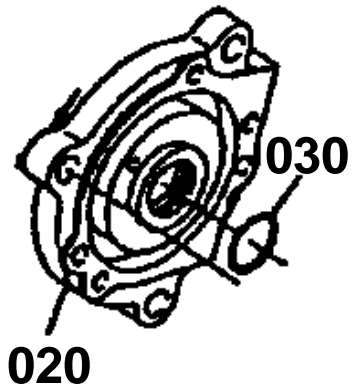

32751-827-10



GST VALVE [GST TYPE] [COMPONENT PARTS]

↔ Interchangeable; ≠ not interchangeable; ← new for old; → old for new

REF.No	Part No.	Description	Q'ty	S.No.	I/C	REMARKS	Weight (kgf)	Weight (lb)
010	TA040-65010	ASSY VALVE GST	1	<=50497		NOT SALE	0	0
010	TA040-65012	ASSY VALVE GST	1	>=50498	-	NOT SALE	0	0
010	TA040-99030	ASSY VALVE GST	1	>=63146	-	NOT SALE	0	0
010	TA040-99034	ASSY VALVE GST	1	>=72643	-		8.45	18.59
020	34076-65510	COVER VALVE	1	<=50497			0	0
020	34076-65512	COVER VALVE	1	>=50498	1		0.12	0.264
020	T0186-65510	COVER VALVE	1	>=62458	1		0.21	0.462
030	04811-00200	O RING	1	<=62457			0	0
030	T0186-65530	SEAL OIL	1	>=62458	1		0.008	0.0176
040	34076-65520	GASKET	1	<=50497		NOT SALE	0.005	0.011
040	04811-10850	O RING	1	>=50498	1		0.002	0.0044
050	01123-50825	BOLT	3				0.013	0.0286
060	08101-06004	BEARING BALL	1				0.065	0.143
070	50770-12180	COLLAR THRUST	1				0.003	0.0066
080	34076-65550	PLATE DETENT	1				0.11	0.242
090	34076-65580	ORIFICE	1			NOT SALE	0.005	0.011
100	07715-01605	BALL	2				0.003	0.0066
110	04811-00060	O RING	9				0	0
110	04817-00060	O RING	9		-		0.002	0.0044
120	32420-67380	PLUG	9				0.005	0.011
130	05012-00406	PIN STRAIGHT	2				0.001	0.0022
140	01311-10645	BOLT HEX-SOC-HD	3				0.01	0.022
150	04810-00120	O RING	1				0	0
150	04817-00120	O RING	1		-		0.001	0.0022
160	34076-65430	BUSH	1				0.005	0.011
170	34076-65910	PLATE SEPARATE	1				0.3	0.66
180	T0276-65880	BOLT HEX-SOC-HD	8				0.008	0.0176
190	T0276-65870	BOLT HEX-SOC-HD	5				0.008	0.0176
200	34076-65850	BOLT	2				0.01	0.022
210	34076-65860	BOLT	5				0.02	0.044
220	04512-60060	WASHER SPRING	7				0.001	0.0022
230	05012-00616	PIN STRAIGHT	2				0.004	0.0088
240	T0276-65990	PLUG	1				0.004	0.0088

GST VALVE [GST TYPE] [COMPONENT PARTS]

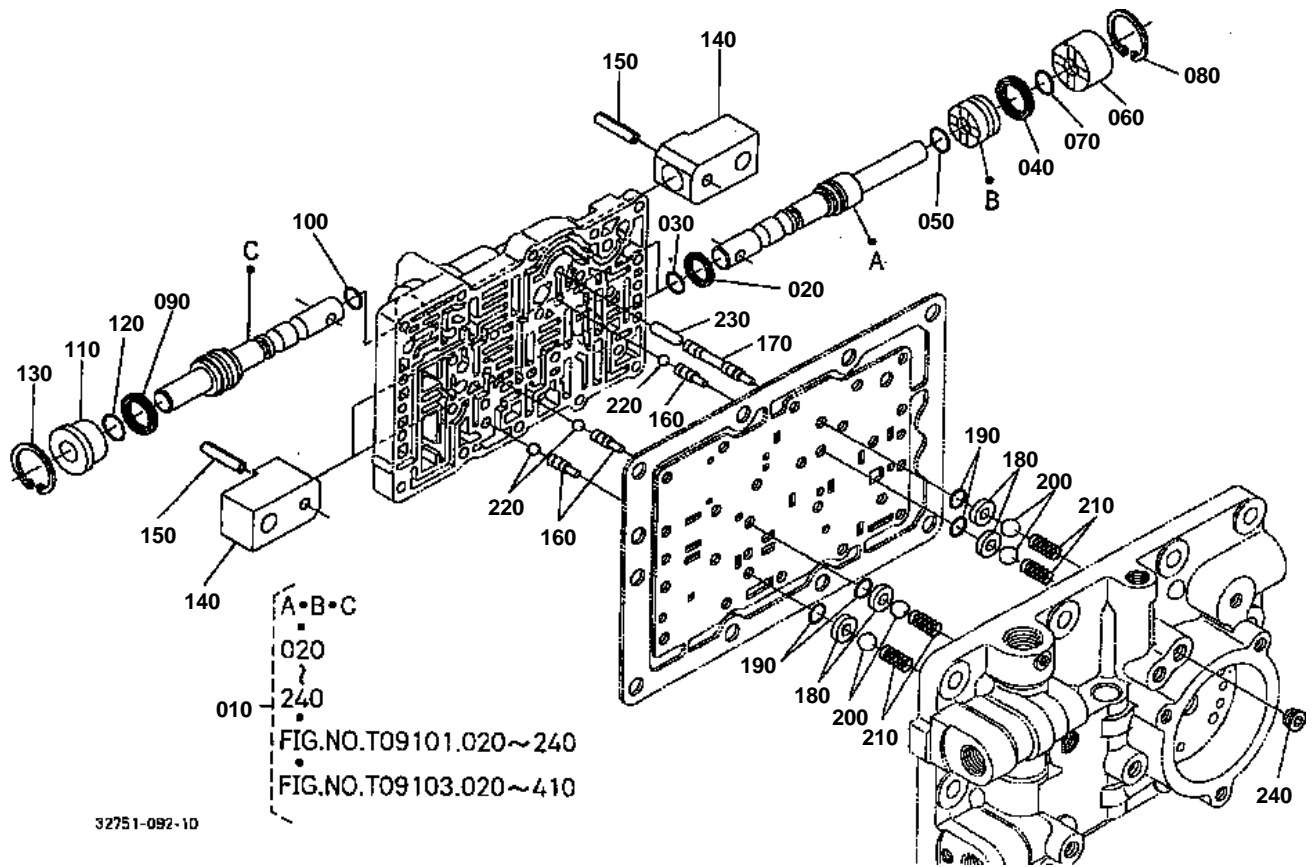



GST VALVE [GST TYPE] [COMPONENT PARTS]

↔ Interchangeable; ≠ not interchangeable; ← new for old; → old for new

REF.No	Part No.	Description	Q'ty	S.No.	I/C	REMARKS	Weight (kgf)	Weight (lb)
010	TA040-65010	ASSY VALVE GST	1	<=50497		NOT SALE	0	0
010	TA040-65012	ASSY VALVE GST	1	>=50498	-	NOT SALE	0	0
010	TA040-99030	ASSY VALVE GST	1	>=63146	-	NOT SALE	0	0
010	TA040-99034	ASSY VALVE GST	1	>=72643	-		8.45	18.59
020	34076-65140	SEAL PISTON	2				0.005	0.011
030	04811-06100	O RING	2				0	0
030	04817-06100	O RING	2		-		0.001	0.0022
040	34076-65170	SEAL PISTON	2				0.005	0.011
050	04811-00110	O RING	2				0	0
050	04817-00110	O RING	2		-		0.001	0.0022
060	34076-65180	COVER PISTON MAIN	2				0.09	0.198
070	04811-00110	O RING	2				0	0
070	04817-00110	O RING	2		-		0.001	0.0022
080	04611-00300	CIR CLIP INTERNAL	2				0.004	0.0088
090	34076-65220	SEAL PISTON	1				0.005	0.011
100	04811-06100	O RING	1				0	0
100	04817-06100	O RING	1		-		0.001	0.0022
110	34076-65240	COVER PISTON HI-LO	1				0.06	0.132
120	04811-00140	O RING	1				0	0
120	04817-00140	O RING	1		-		0.001	0.0022
130	04611-00300	CIR CLIP INTERNAL	1				0.004	0.0088
140	34076-65270	SHIFTER PISTON	3				0.135	0.297
150	05411-00625	PIN SPRING	3				0.004	0.0088
160	34076-65930	PIN CHECK	3				0.005	0.011
170	34076-65940	PIN CHECK	1				0.01	0.022
180	34076-65450	SEAT VALVE	4				0.005	0.011
190	04811-06100	O RING	4				0	0
190	04817-06100	O RING	4		-		0.001	0.0022
200	07715-03213	BALL	4				0.004	0.0088
210	34076-65470	SPRING CHECK	4				0.005	0.011
220	07715-00401	BALL	3				0.001	0.0022
230	34076-65950	PIN CHECK ROLLER	1				0.005	0.011
240	67511-36640	PLUG	4				0.003	0.0066

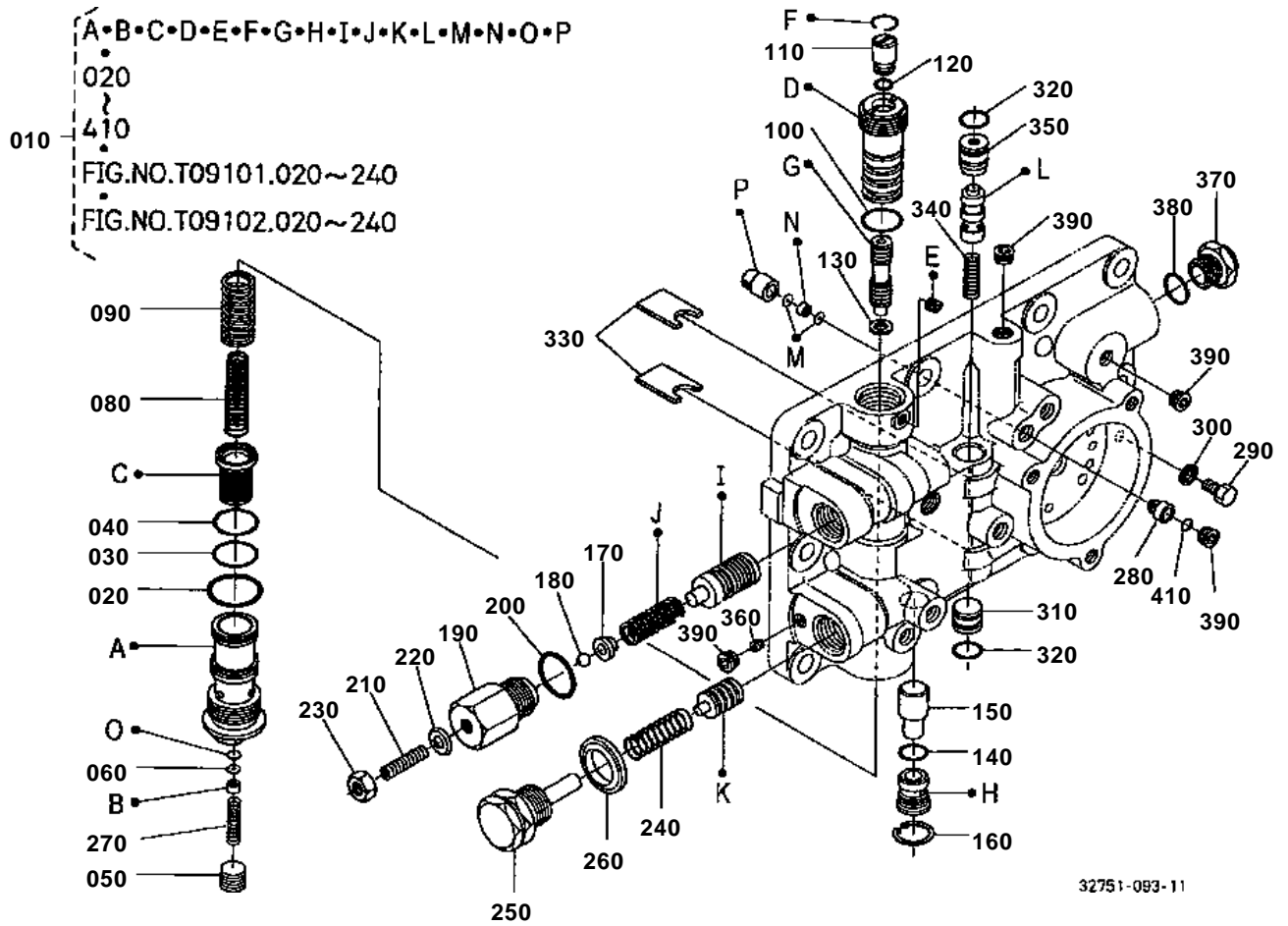

270 34076-6583-0

280 34076-6584-0

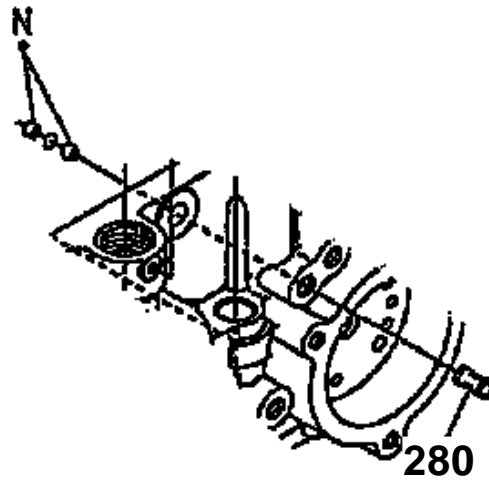
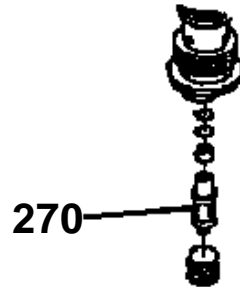

TA150-822-10



GST VALVE [GST TYPE] [COMPONENT PARTS]

↔ Interchangeable; ≠ not interchangeable; ← new for old; → old for new

REF.No	Part No.	Description	Q'ty	S.No.	I/C	REMARKS	Weight (kgf)	Weight (lb)
010	TA040-65010	ASSY VALVE GST	1	<=50497		NOT SALE	0	0
010	TA040-65012	ASSY VALVE GST	1	>=50498	↔	NOT SALE	0	0
010	TA040-99030	ASSY VALVE GST	1	>=63146	↔	NOT SALE	0	0
010	TA040-99034	ASSY VALVE GST	1	>=72643	↔		8.45	18.59
020	04811-00260	O RING	1				0	0
020	04816-00260	O RING	1		«		0.001	0.0022
030	04811-10240	O RING	1				0.001	0.0022
040	04811-16220	RING	1				0.001	0.0022
050	34076-65800	PLUG	1				0.01	0.022
060	34076-65820	ORIFICE	1				0.005	0.011
070	99999-99999	BLANK	0				0	0
080	34550-65770	SPRING	1				0.02	0.044
090	34076-65760	SPRING RETURN	1				0.02	0.044
100	04811-00180	O RING	1				0	0
100	04816-00180	O RING	1		«		0.002	0.0044
110	34076-65750	PLUG	1				0.015	0.033
120	04811-00070	O RING	1				0	0
120	04816-00070	O RING	1		«		0.001	0.0022
130	04013-60060	WASHER PLAIN	1				0.001	0.0022
140	04811-10120	O RING	1				0.001	0.0022
150	67950-29230	POPPET	1				0.015	0.033
160	04611-00160	CIR CLIP INTERNAL	1				0.001	0.0022
170	34076-65390	SUPPORT	1				0.005	0.011
180	07715-00401	BALL	1				0.001	0.0022
190	34076-65380	PLUG	1				0.115	0.253
200	04811-00200	O RING	1				0	0
200	04816-00200	O RING	1		«		0.003	0.0066
210	03651-50825	SCREW SET	1				0.01	0.022
220	62571-13330	WASHER SEAL	1				0.003	0.0066
230	02114-50080	NUT	1				0.005	0.011
240	34076-65320	SPRING	1				0.005	0.011
250	34550-65330	PLUG	1				0.06	0.132
260	04717-01800	WASHER WITH RUBBER	1				0.003	0.0066
270	34076-65830	FILTER MODULATION	1	<=72642			0	0
270	3G999-00300	SPRING FILTER	1	>=72643	↔		0.004	0.0088
280	34076-65840	FILTER PILOT	1	<=72642			0	0
280	3F750-23710	FILTER	1	>=72643	↔		0.002	0.0044
290	01053-50608	BOLT	1				0.004	0.0088
300	04717-00600	WASHER WITH RUBBER	1				0.001	0.0022
310	34076-65680	PLUG	1				0.025	0.055
320	04811-00140	O RING	2				0	0
320	04816-00140	O RING	2		«		0.002	0.0044
330	34076-65650	PLATE STOPPER	2				0.005	0.011
340	34076-65660	SPRING	1				0.005	0.011
350	34076-65690	PLUG	1				0.03	0.066
360	32420-67380	PLUG	1				0.005	0.011
370	34076-65630	PLUG	1				0.035	0.077
380	04811-00140	O RING	1				0	0
380	04816-00140	O RING	1		«		0.002	0.0044
390	67511-36640	PLUG	4				0.003	0.0066
400	99999-99999	BLANK	0				0	0



GST VALVE [GST TYPE] [COMPONENT PARTS]

↔ Interchangeable; ≠ not interchangeable; ← new for old; → old for new

REF.No	Part No.	Description	Q'ty	S.No.	I/C	REMARKS	Weight (kgf)	Weight (lb)
410	04811-00050	O RING	1				0	0
410	04816-00050	O RING	1		<<		0.001	0.0022

REGULATOR VALVE

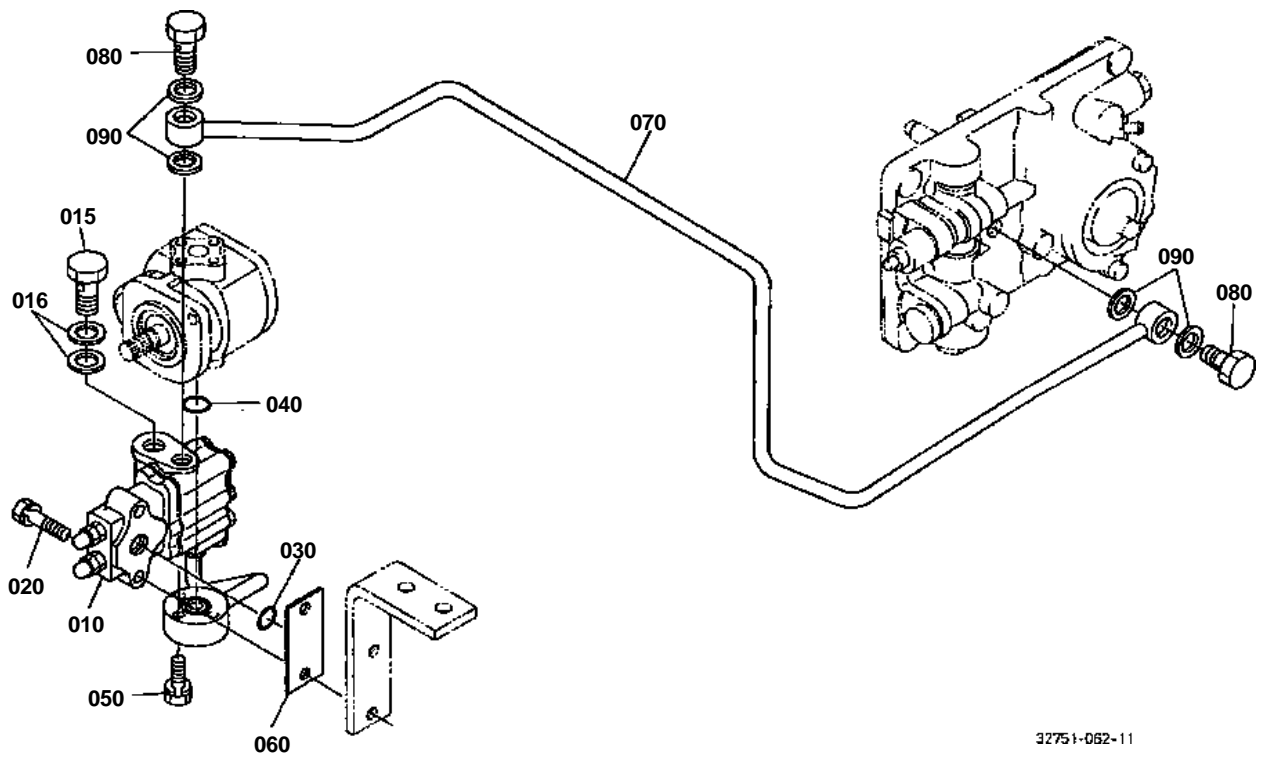

32751-062-11



REGULATOR VALVE

↔ Interchangeable; ≠ not interchangeable; ← new for old; → old for new

REF.No	Part No.	Description	Q'ty	S.No.	I/C	REMARKS	Weight (kgf)	Weight (lb)
010	32751-66010	ASSY VALVE REGULATOR	1	<=73018			0	0
010	32751-66050	ASSY VALVE REGULATOR	1	>=73019	-		1.85	4.07
015	66591-36250	JOINT	1				0.08	0.176
016	67111-37180	GASKET	2				0.003	0.0066
020	01123-50840	BOLT	2				0.018	0.0396
030	04811-00200	O RING	1				0	0
030	04816-00200	O RING	1		«		0.003	0.0066
040	04810-00200	O RING	1				0	0
040	04817-00200	O RING	1		«		0.011	0.0242
050	01123-50835	BOLT	3				0.02	0.044
060	32751-66300	PLATE	1				0.024	0.0528
070	32751-66530	COMP.PIPE GST	1				0.35	0.77
080	34076-66590	BOLT JOINT	2				0.05	0.11
090	04714-00200	GASKET	4				0.002	0.0044

HYDRAULIC PUMP

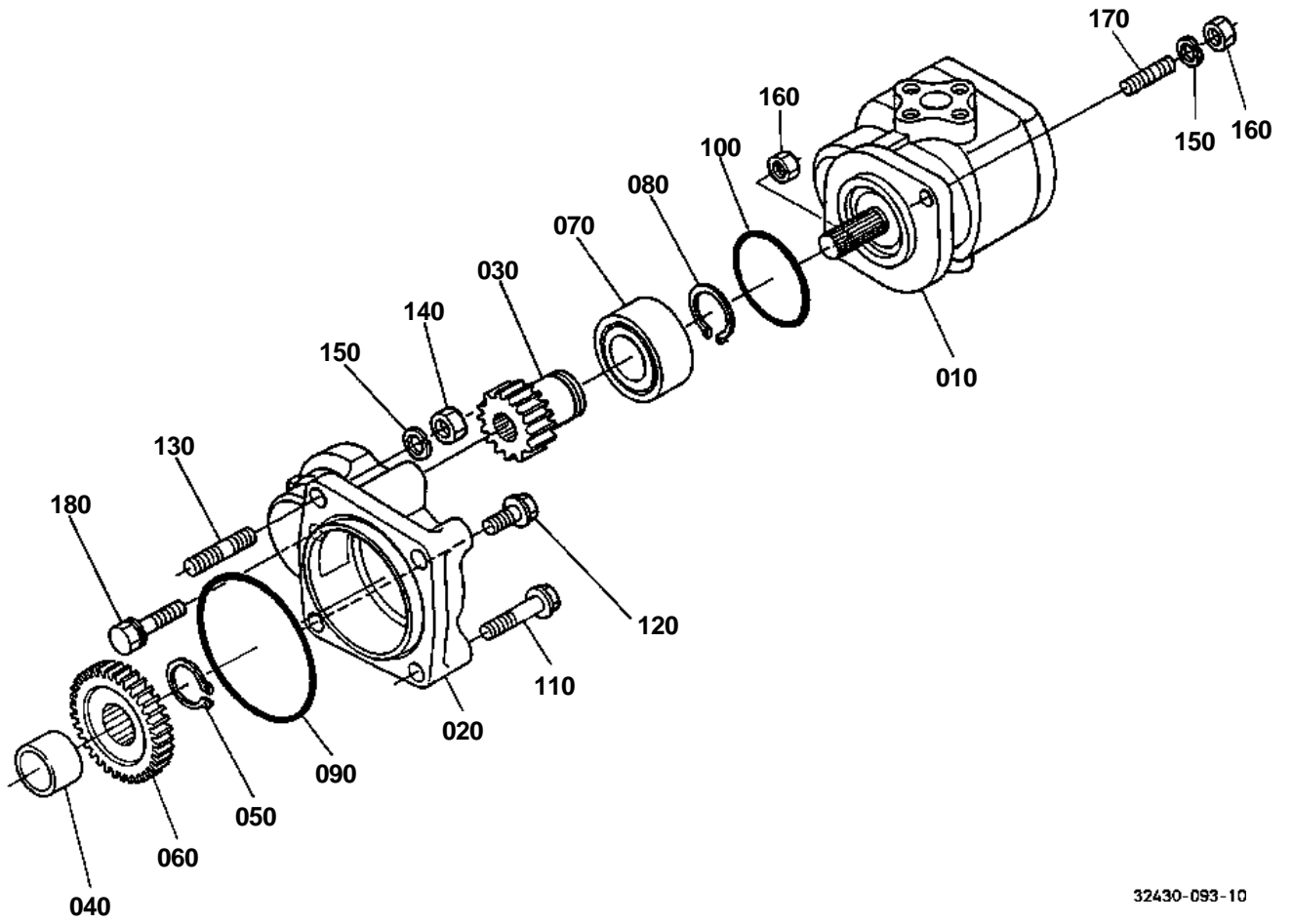

32430-093-10



HYDRAULIC PUMP

↔ Interchangeable; ≠ not interchangeable; ← new for old; → old for new

REF.No	Part No.	Description	Q'ty	S.No.	I/C	REMARKS	Weight (kgf)	Weight (lb)
010	31351-76102	ASSY PUMP HYDRAULIC	1				1.66	3.652
020	31351-38613	HOLDER PUMP	1				0.38	0.836
030	31391-76520	GEAR	1			17T	0.16	0.352
040	34150-37820	COLLAR	1				0.05	0.11
050	04612-00250	CIRCLIP EXTERNAL	1				0.002	0.0044
060	31391-37810	GEAR	1			34T	0.33	0.726
070	08241-05205	BEARING BALL	1				0.177	0.3894
080	04612-00250	CIRCLIP EXTERNAL	1				0.002	0.0044
090	04811-10850	O RING	1				0.002	0.0044
100	04811-10500	O RING	1				0.001	0.0022
110	01754-50840	BOLT FLANGE	2				0.02	0.044
120	01754-50820	BOLT FLANGE	1				0.015	0.033
130	38240-36330	STUD	1				0.008	0.0176
140	02156-50080	NUT	1				0.004	0.0088
150	04512-50080	WASHER SPRING	2				0	0
160	02156-50080	NUT	2				0.004	0.0088
170	01513-50820	STUD	1				0	0
180	01123-50840	BOLT	1				0.018	0.0396

HYDRAULIC PUMP [COMPONENT PARTS]

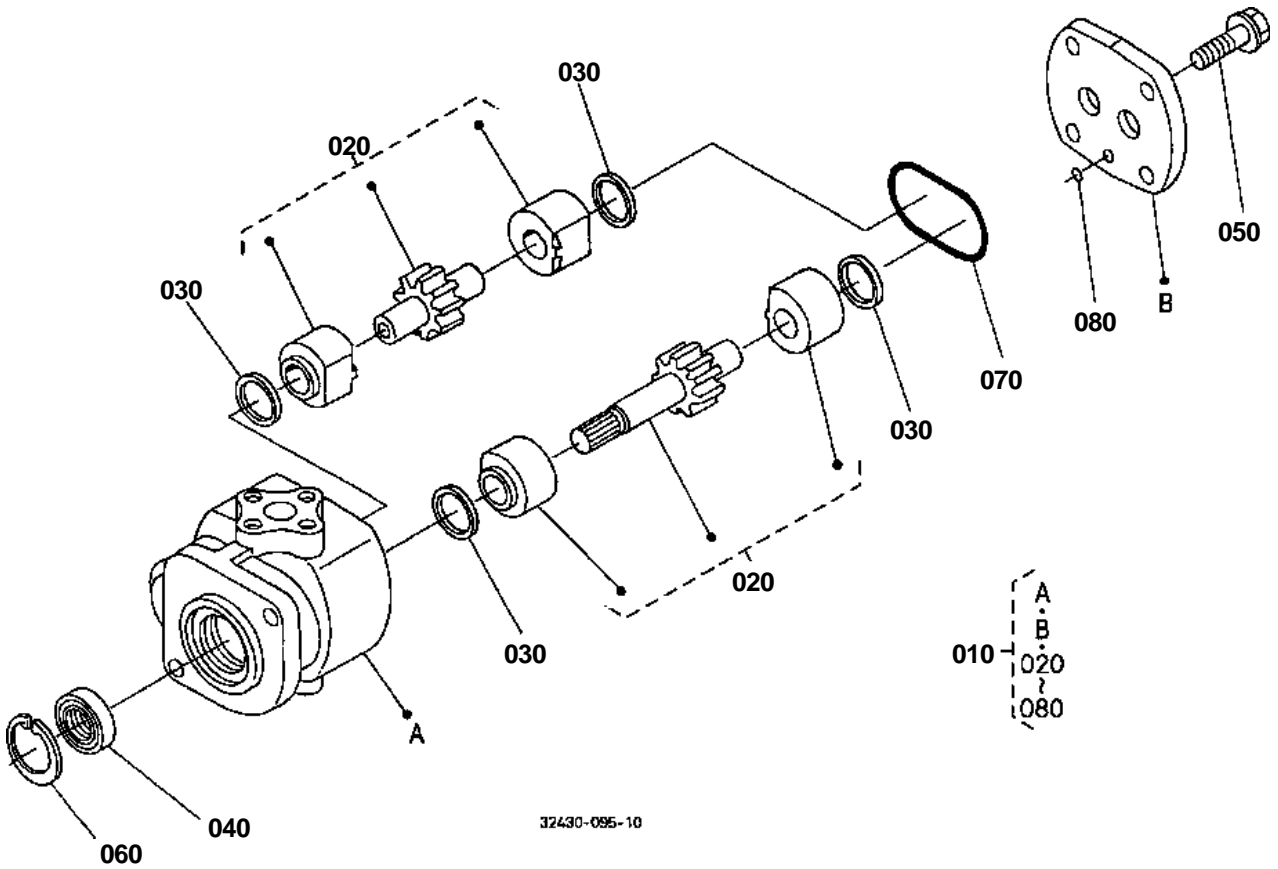



HYDRAULIC PUMP [COMPONENT PARTS]

↔ Interchangeable; ≠ not interchangeable; ← new for old; → old for new

REF.No	Part No.	Description	Q'ty	S.No.	I/C	REMARKS	Weight (kgf)	Weight (lb)
010	31351-76102	ASSY PUMP HYDRAULIC	1				1.66	3.652
020	31351-76202	COMP.GEAR HYD.PUMP	1				0.49	1.078
030	38180-76172	SQUARE RING	4				0.002	0.0044
040	31381-76390	SEAL OIL	1				0.01	0.022
050	01754-51030	BOLT FLANGE	4				0.03	0.066
060	04611-00300	CIR CLIP INTERNAL	1				0.004	0.0088
070	04810-50550	O RING	1				0.002	0.0044
080	04810-00050	O RING	1				0	0
080	04817-00050	O RING	1		«		0.001	0.0022

HYDRAULIC PUMP

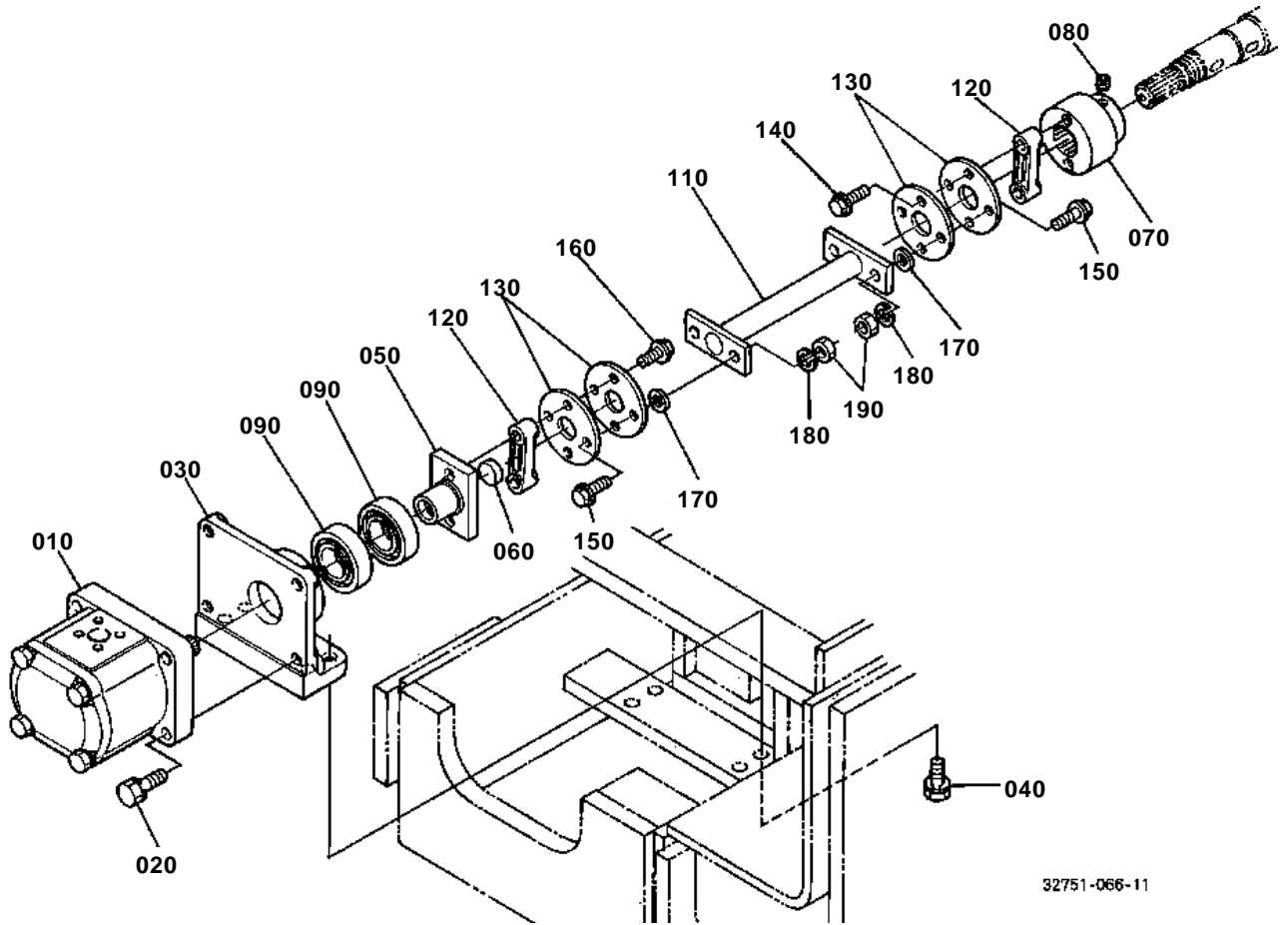

32751-066-11

090 32590-1083-0

100 31351-2514-0

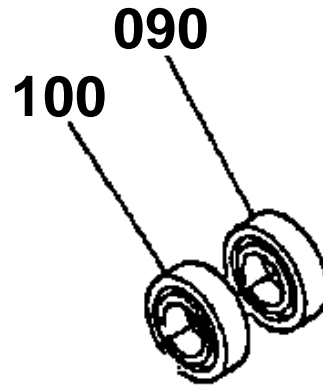

32751-824-10

**HYDRAULIC PUMP**

↔ Interchangeable; ≠ not interchangeable; ← new for old; → old for new

REF.No	Part No.	Description	Q'ty	S.No.	I/C	REMARKS	Weight (kgf)	Weight (lb)
010	33660-82200	PUMP HYDRAULIC	1				2.66	5.852
020	01123-50835	BOLT	4				0.02	0.044
030	32751-10890	BRACKET FRONT PUMP	1				1.5	3.3
040	01133-51030	BOLT	4				0.025	0.055
050	32751-10910	COUPLING	1				0.21	0.462
060	06311-75020	PLUG	1				0.004	0.0088
070	32751-10920	COUPLING	1				0.615	1.353
080	03651-50608	SCREW SET	3				0.001	0.0022
090	32590-10830	BEARING BALL	1	<=71695			0.1	0.22
090	32590-10830	BEARING BALL	2	>=71696			0.1	0.22
100	31351-25140	BEARING BALL	1	<=71695			0.11	0.242
110	32751-10930	SHAFT COUPLING	1	<=73720			0.37	0.814
110	32751-10932	SHAFT COUPLING	1	>=73721	→		0.37	0.814
120	31351-17870	SPACER	2				0.03	0.066
130	31351-17880	DISK COUPLING	4				0	0
130	32771-10850	PLATE COUPLING	4		«		0.009	0.0198
140	01754-50835	BOLT FLANGE	2				0.019	0.0418
150	01754-50820	BOLT FLANGE	4				0.015	0.033
160	01754-50830	BOLT FLANGE	2				0.05	0.11
170	04013-50080	WASHER PLAIN	4				0	0
180	04512-50080	WASHER SPRING	4				0	0
190	02114-50080	NUT	4				0.005	0.011

HYDRAULIC PUMP [COMPONENT PARTS]

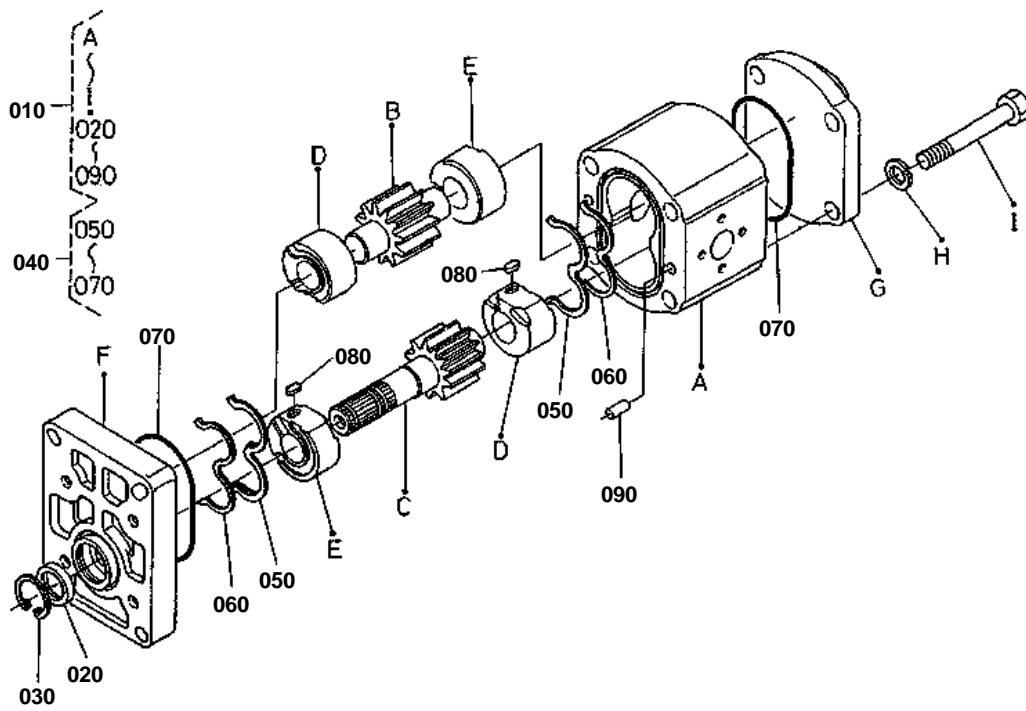

33740-133-10



HYDRAULIC PUMP [COMPONENT PARTS]

↔ Interchangeable; ≠ not interchangeable; ← new for old; → old for new

REF.No	Part No.	Description	Q'ty	S.No.	I/C	REMARKS	Weight (kgf)	Weight (lb)
010	33660-82200	PUMP HYDRAULIC	1				2.66	5.852
020	36330-82320	SEAL OIL	1				0.01	0.022
030	68051-91850	RING SNAP	1				0.001	0.0022
040	36330-82480	SET SEAL	1				0.005	0.011
050	35430-12870	ELEMENT SEAL	2				0.003	0.0066
060	68051-91880	ELEMENT BACK UP	2				0.001	0.0022
070	68051-91910	O RING	2				0.001	0.0022
080	68051-91890	KEY	2				0.001	0.0022
090	68271-91240	PIN	2				0.004	0.0088

HYDRAULIC OIL LINE (INLET)

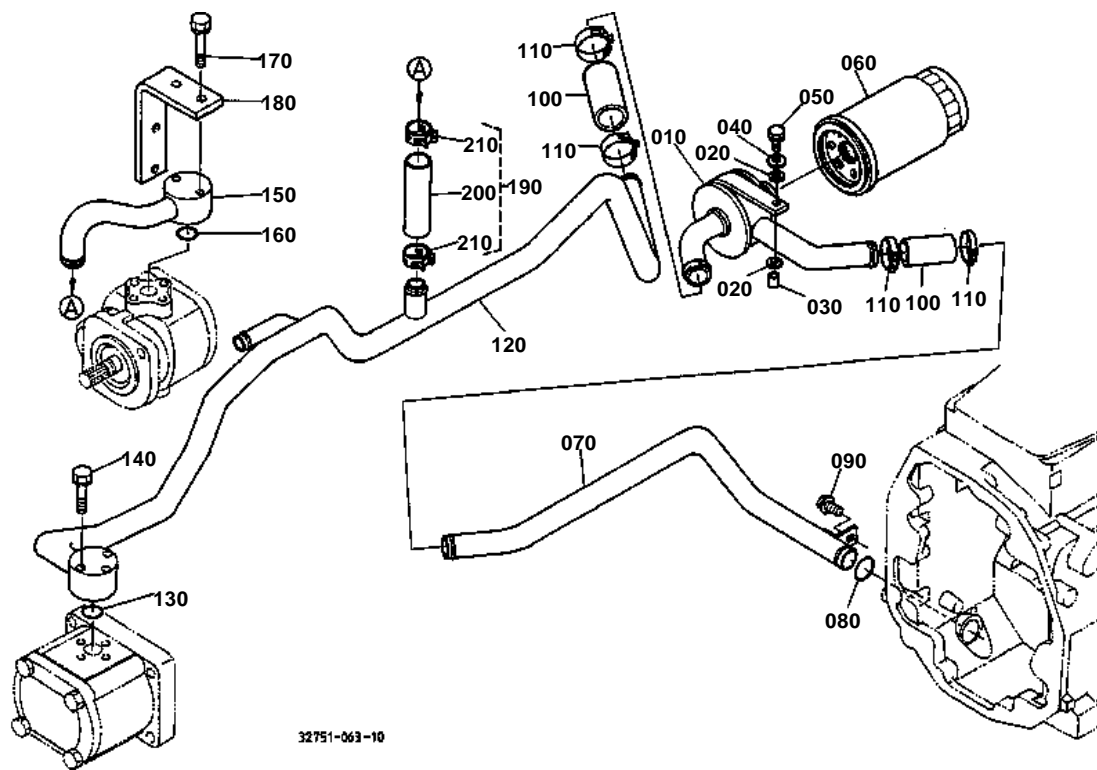



HYDRAULIC OIL LINE (INLET)

↔ Interchangeable; ≠ not interchangeable; ← new for old; → old for new

REF.No	Part No.	Description	Q'ty	S.No.	I/C	REMARKS	Weight (kgf)	Weight (lb)
010	32751-33210	BRACKET FILTER	1				0.92	2.024
020	67111-52160	CUSHION	2				0.003	0.0066
030	38240-29940	SPACER	1				0.005	0.011
040	04015-50100	WASHER PLAIN	1				0	0
050	01133-51030	BOLT	1				0.025	0.055
060	32590-38380	FILTER OIL	1				0.67	1.474
070	32751-33310	COMP.PIPE INLET	1				0.5	1.1
080	04810-00260	O RING	1				0	0
080	04817-00260	O RING	1		→		0.004	0.0088
090	01754-50812	BOLT FLANGE	1				0.01	0.022
100	34350-37774	PIPE RUBBER	2				0.06	0.132
110	31351-38180	BAND PIPE	4				0	0
120	32751-33320	COMP.PIPE INLET	1				1.7	3.74
130	04811-00220	O RING	1				0	0
130	04817-00220	O RING	1		→		0.001	0.0022
140	01023-60650	BOLT	3				0.015	0.033
150	32751-33330	COMP.PIPE INLET	1				0.52	1.144
160	04811-00220	O RING	1				0	0
160	04817-00220	O RING	1		→		0.001	0.0022
170	01123-50860	BOLT	2				0.002	0.0044
180	32751-33350	BRACKET VALVE	1				0.555	1.221
190	32751-33340	ASSY HOSE INLET	1			NOT SALE	0	0
200	37410-38622	PIPE INLET	1				0.06	0.132
210	66361-37190	BAND PIPE	2				0.001	0.0022

HYDRAULIC OIL LINE (DELIVERY)

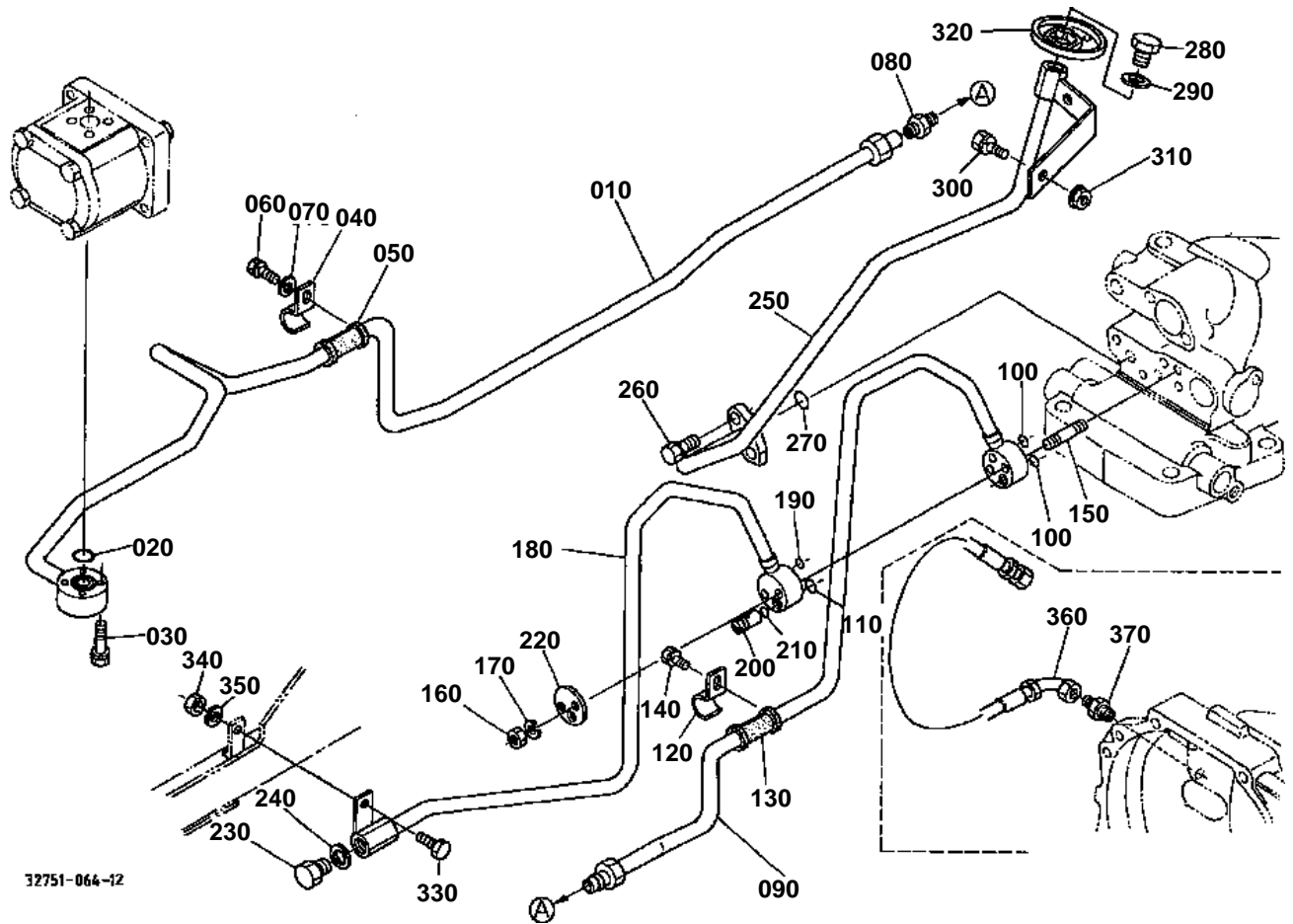

32751-064-12

090 32751-3342-0

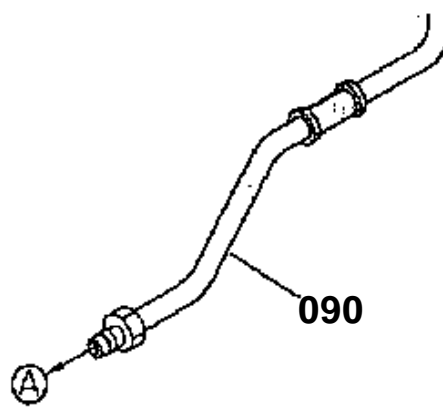

090 32751-3342-4

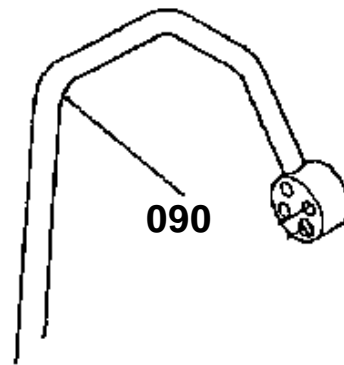

180 32751-3343-0

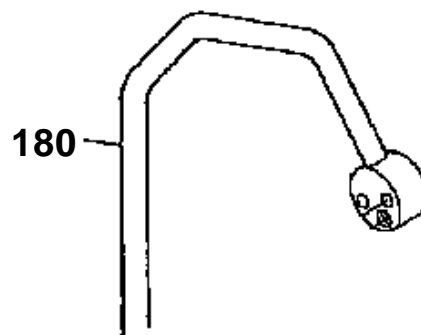

32751-809-11



HYDRAULIC OIL LINE (DELIVERY)

↔ Interchangeable; ≠ not interchangeable; ← new for old; → old for new

REF.No	Part No.	Description	Q'ty	S.No.	I/C	REMARKS	Weight (kgf)	Weight (lb)
010	32751-33410	COMP.PIPE DELIVERY	1				1.12	2.464
020	04810-00200	O RING	1				0	0
020	04817-00200	O RING	1		←		0.011	0.0242
030	01023-50635	BOLT	4				0.01	0.022
040	34070-33260	HOLDER	1				0.03	0.066
050	34550-33290	TUBE	1				0.01	0.022
060	01133-51016	BOLT	1				0.015	0.033
070	04013-50100	WASHER PLAIN	1				0	0
080	32530-38720	JOINT PIPE	1				0	0
080	06013-51502	JOINT	1	≤72348	«		0.03	0.066
080	06013-51503	JOINT PIPE	1	≥72349	1		0.062	0.1364
090	32751-33420	COMP.PIPE DELIVERY	1	≤60382		NOT SALE	0	0
090	32751-33424	COMP.PIPE DELIVERY	1	≥60383	←	NOT SALE	0.7	1.54
090	32751-33425	COMP.PIPE DELIVERY	1	≥70271	1		0.7	1.54
100	04810-00100	O RING	2				0	0
100	04817-00100	O RING	2		«		0.001	0.0022
110	04810-00140	O RING	1				0	0
110	04817-00140	O RING	1		«		0.001	0.0022
120	34070-33260	HOLDER	1				0.03	0.066
130	34550-33290	TUBE	1				0.01	0.022
140	01133-51016	BOLT	1				0.015	0.033
150	01513-50855	STUD	2	≤70270			0.022	0.0484
150	01513-50860	STUD	2	≥70271	1		0.024	0.0528
160	02114-50080	NUT	2				0.005	0.011
170	04512-60080	WASHER SPRING	2				0.002	0.0044
180	32751-33430	COMP.PIPE DELIVERY	1	≤70270			0.73	1.606
180	32751-33435	COMP.PIPE DELIVERY	1	≥70271	1		0.73	1.606
190	04810-00100	O RING	1				0	0
190	04817-00100	O RING	1		«		0.001	0.0022
200	32751-33450	SPOOL	1	≤70270		NOT SALE	0.01	0.022
200	32751-33454	SPOOL	1	≥70271	1		0.01	0.022
210	04810-00070	O RING	1				0	0
210	04817-00070	O RING	1		«		0.001	0.0022
220	32751-33480	PLATE	1				0.031	0.0682
230	06311-55040	PLUG	1				0.093	0.2046
230	15512-96010	PLUG	1		«		0.101	0.2222
240	04714-00400	GASKET	1				0.003	0.0066
240	04717-02150	WASHER WITH RUBBER	1		«		0.004	0.0088
250	32751-33440	COMP.PIPE DELIVERY	1				0.72	1.584
260	01123-50820	BOLT	2				0.011	0.0242
270	04810-00180	O RING	1				0	0
270	04817-00180	O RING	1		«		0.003	0.0066
280	06311-55040	PLUG	1				0.093	0.2046
280	15512-96010	PLUG	1		«		0.101	0.2222
290	04714-00400	GASKET	1				0.003	0.0066
290	04717-02150	WASHER WITH RUBBER	1		«		0.004	0.0088
300	01123-50825	BOLT	1				0.013	0.0286
310	02751-50080	NUT FLANGE	1				0.006	0.0132
320	32751-33470	TRAY	1				0.017	0.0374
330	75599-03320	BOLT	1				0.02	0.044
340	75599-31013	NUT	1				0.006	0.0132



HYDRAULIC OIL LINE (DELIVERY)

↔ Interchangeable; ≠ not interchangeable; ← new for old; → old for new

REF.No	Part No.	Description	Q'ty	S.No.	I/C	REMARKS	Weight (kgf)	Weight (lb)
350	75599-33013	WASHER SPRING	1				0.006	0.0132
350	0Y450-50060	WASHER SPRING	1		-		0.003	0.0066
360	32751-33710	HOSE HYDRAULIC	1	>=60001			0.5	1.1
370	32751-33720	JOINT	1	>=60001			0.08	0.176

HYDRAULIC CYLINDER

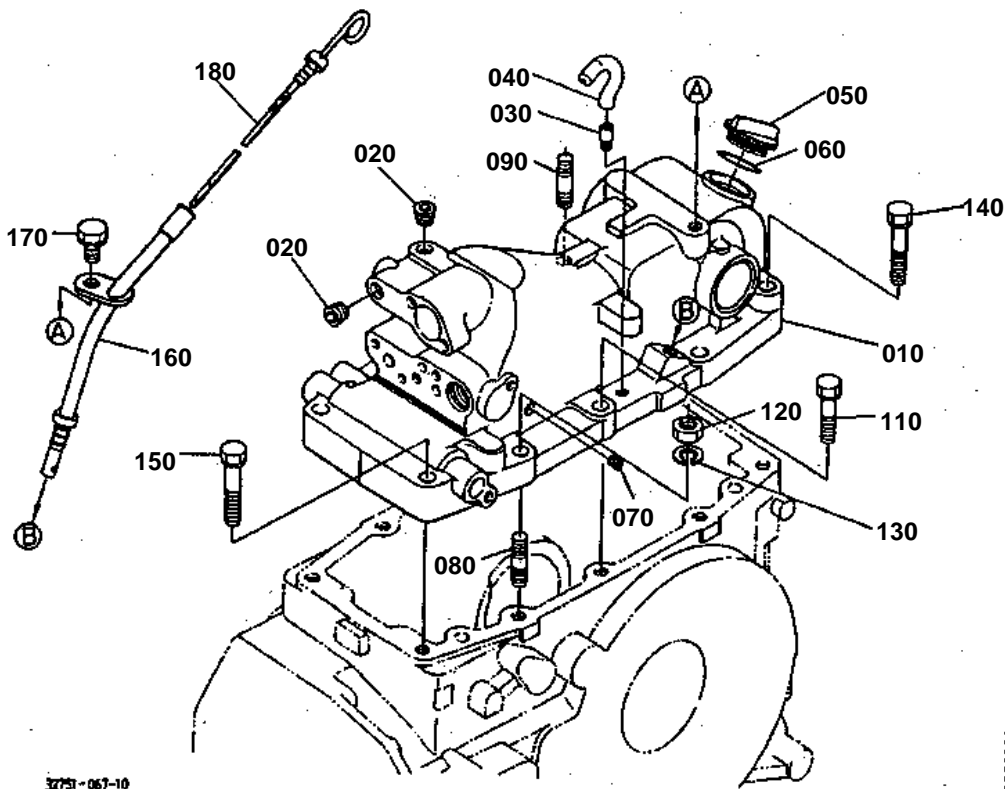

001 32751-3413-0
 190 TA040-3842-0
 200 02112-50080
 210 04613-50060

010
 .
 190
 }
 001 210
 .
 T100-090 · 100
 T101-160~190

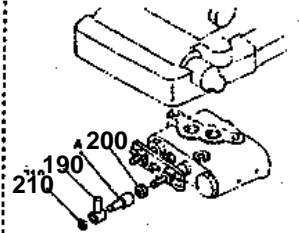

32751-067-10

001 32751-3413-0
190 TA040-3642-0
200 02112-50080
210 04613-50060

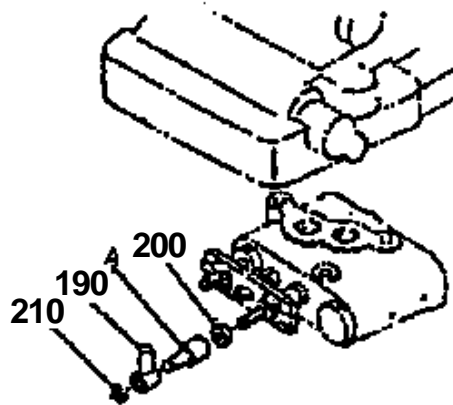
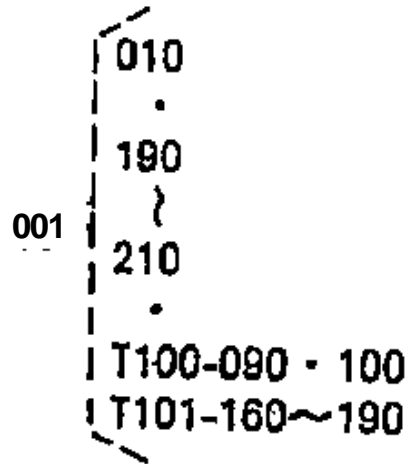

32751-828-10



HYDRAULIC CYLINDER

↔ Interchangeable; ≠ not interchangeable; ← new for old; → old for new

REF.No	Part No.	Description	Q'ty	S.No.	I/C	REMARKS	Weight (kgf)	Weight (lb)
001	32751-34130	ASSY CASE HYD.CYLIND	1	<=62269			21	46.2
010	32751-34110	CASE HYD.CYLINDER	1	<=62269		NOT SALE ORDER BY REF.No.001	21	46.2
010	32751-34114	CASE HYD.CYLINDER	1	>=62270	↔		21	46.2
020	31351-37150	PLUG	5				0.007	0.0154
030	36200-21610	BREATHER	1				0.008	0.0176
040	31351-37140	BREATHER	1				0.01	0.022
050	38240-21410	PLUG	1				0.015	0.033
060	04811-50300	O RING	1				0	0
060	04816-50300	O RING	1		↔		0.001	0.0022
070	31351-37160	PLUG	4				0.003	0.0066
080	34070-34810	BOLT STUD	1	<=72302			0	0
080	01574-51245	STUD	1	>=72303	↔		0.051	0.1122
090	01574-51245	STUD	1				0.051	0.1122
100	99999-99999	BLANK	0				0	0
110	01133-51245	BOLT	4				0.055	0.121
120	02176-50120	NUT	2				0.01	0.022
130	04512-50120	WASHER SPRING	2				0	0
140	01133-51260	BOLT	2				0.06	0.132
150	01133-51255	BOLT	2				0.06	0.132
160	32751-29410	GUIDE OIL GAUGE	1				0.08	0.176
170	01133-51018	BOLT	1				0.018	0.0396
180	32751-29420	GAUGE OIL	1				0.045	0.099
190	TA040-36420	JOINT SPOOL	1	<=62269			0.022	0.0484
200	02112-50080	NUT	1	<=62269			0.003	0.0066
210	04613-50060	CIRCLIP EXTERNAL	1	<=62269			0.001	0.0022

LIFT ARM

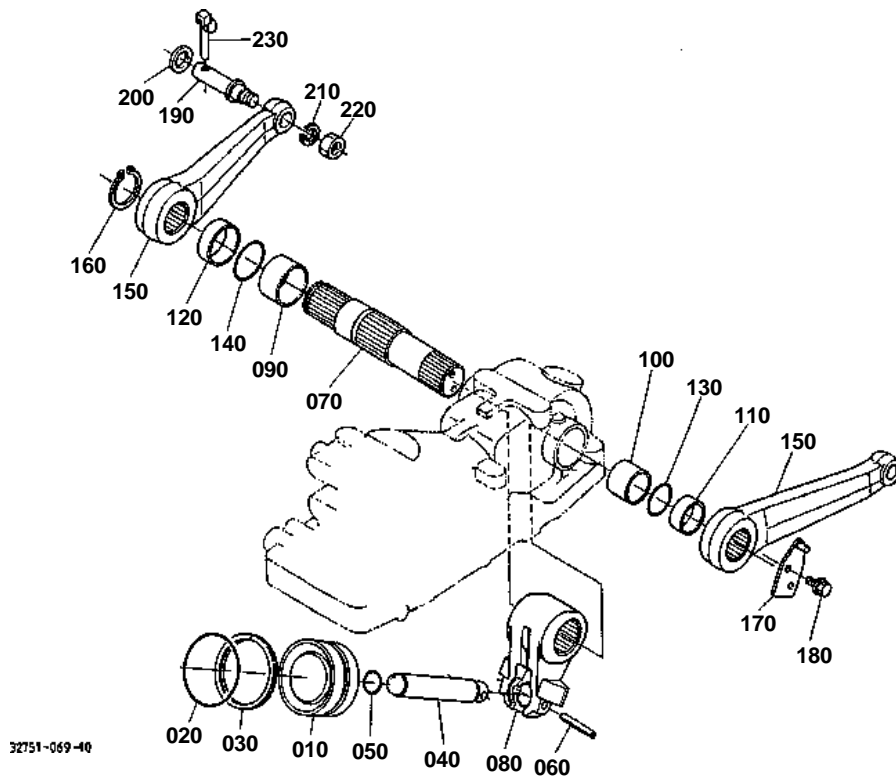



LIFT ARM

↔ Interchangeable; ≠ not interchangeable; ← new for old; → old for new

REF.No	Part No.	Description	Q'ty	S.No.	I/C	REMARKS	Weight (kgf)	Weight (lb)
010	34070-34210	PISTON HYD.	1	<=70405			0	0
010	34070-34214	PISTON HYD.	1	>=70406	-		1.585	3.487
020	04810-00800	O RING	1				0.009	0.0198
030	31391-37330	RING BACK UP	1				0.005	0.011
040	31351-37320	ROD HYD	1				0.605	1.331
050	04810-00240	O RING	1				0	0
050	04817-00240	O RING	1		«		0.003	0.0066
060	05411-00656	PIN SPRING	1				0.006	0.0132
070	31321-37430	SHAFT HYD.ARM	1				2.22	4.884
080	TA040-34230	ARM HYDRAULIC	1	<=50007			0	0
080	TA040-34232	ARM HYDRAULIC	1	>=50008	-		0	0
080	TA040-34234	ARM HYDRAULIC	1	>=72309	-		2.2	4.84
090	31321-37450	BUSH	1				0.09	0.198
100	34150-37460	BUSH	1				0.062	0.1364
110	34150-37490	COLLAR	1				0.002	0.0044
120	34150-37480	COLLAR	1				0.005	0.011
130	04811-06400	O RING	1				0	0
130	04816-06400	O RING	1		«		0.001	0.0022
140	04811-50450	O RING	1				0	0
140	04816-50450	O RING	1		«		0.001	0.0022
150	TA040-34610	ARM LIFT	2				2.22	4.884
160	04612-00400	CIRCLIP EXTERNAL	1				0.005	0.011
170	31351-37720	LINK CONTROL	1				0	0
180	01754-50812	BOLT FLANGE	2				0.01	0.022
190	30442-37690	PIN LIFT ROD	2				0.2	0.44
200	04011-50180	WASHER PLAIN	2				0.012	0.0264
210	04512-60160	WASHER SPRING	2				0.01	0.022
220	02174-50160	NUT	2				0.022	0.0484
230	34150-37640	PIN SET	2				0.06	0.132

CONTROL VALVE

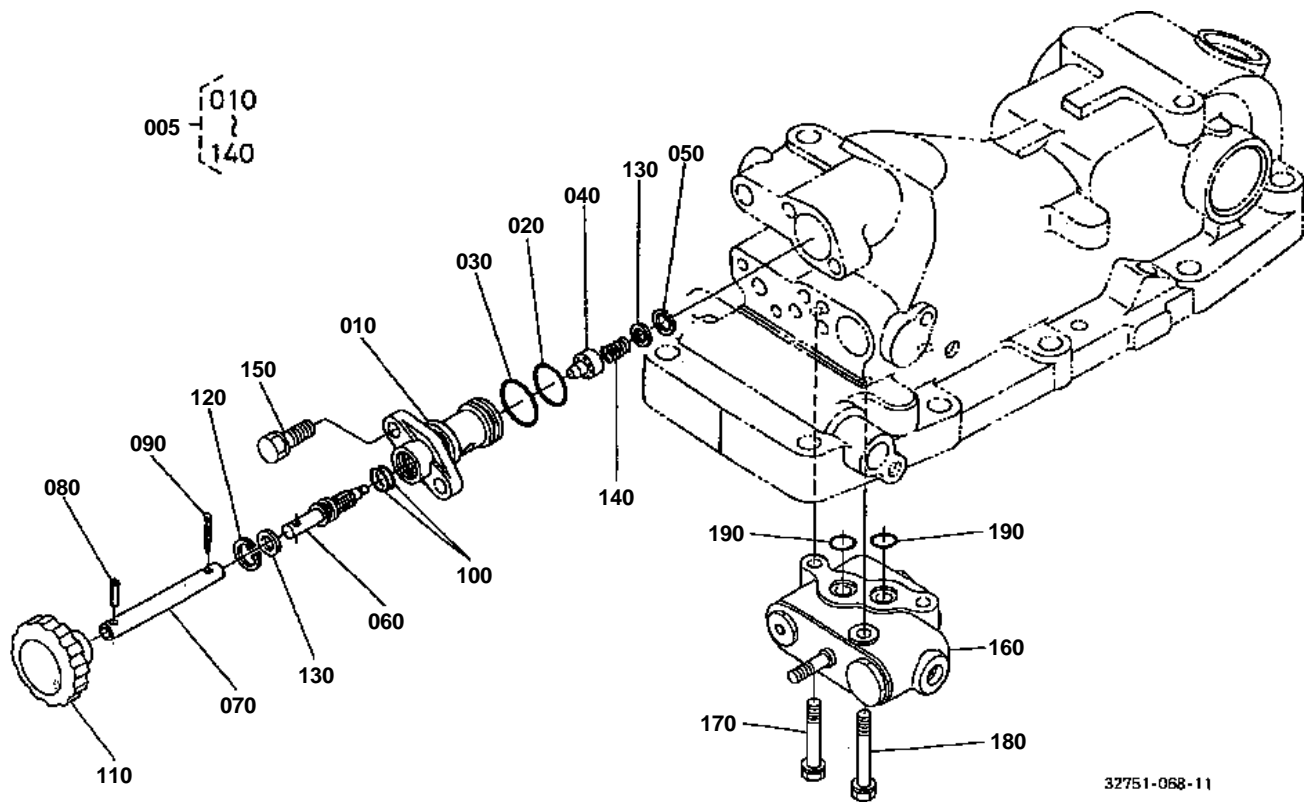

32751-068-11

160 35080-3910-0
170 01123-50845
180 TA040-3640-0
200 35080-3970-0

200 {
160
{
180

T0220-801-10

**CONTROL VALVE**

↔ Interchangeable; ≠ not interchangeable; ← new for old; → old for new

REF.No	Part No.	Description	Q'ty	S.No.	I/C	REMARKS	Weight (kgf)	Weight (lb)
005	TA040-34500	ASSY VALVE	1				0.215	0.473
010	31351-37210	COVER CYL.FRONT	1				0.315	0.693
020	04810-00220	O RING	1				0	0
020	04817-00220	O RING	1		→		0.001	0.0022
030	04810-06250	O RING	1				0	0
030	04817-06250	O RING	1		→		0.001	0.0022
040	38240-37250	COLLAR ADJUSTING	1				0.01	0.022
050	04611-00160	CIR CLIP INTERNAL	1				0.001	0.0022
060	T0070-34510	SHAFT	1				0.04	0.088
070	TA040-34570	PIPE	1				0.035	0.077
080	05411-00414	PIN SPRING	1				0.001	0.0022
090	05511-50425	PIN SPLIT	1				0.003	0.0066
100	04810-00100	O RING	2				0	0
100	04817-00100	O RING	2		→		0.001	0.0022
110	T0070-34560	GRIP	1				0.011	0.0242
120	34150-37260	CIR CLIP INTERNAL	1				0.001	0.0022
130	04012-50080	WASHER PLAIN	2				0.001	0.0022
140	30812-37360	SPRING	1				0.005	0.011
150	01123-50825	BOLT	2				0.013	0.0286
160	35080-39100	ASSY VALVE CONTROL	1	<=62269		NOT SALE	1.6	3.52
160	35080-39102	ASSY VALVE CONTROL	1	>=62270	→		1.7	3.74
170	01123-50845	BOLT	1				0.02	0.044
180	01123-50850	BOLT	2	<=62269			0.02	0.044
180	01123-50848	BOLT	2	>=62270	→		0.02	0.044
180	TA040-36400	BOLT	2	<=62269			0.02	0.044
190	04810-00120	O RING	2				0	0
190	04817-00120	O RING	2		→		0.001	0.0022
200	35080-39700	ASSY VALVE CTR BOLTS	1	<=62269			1.7	3.74

CONTROL VALVE [COMPONENT PARTS]

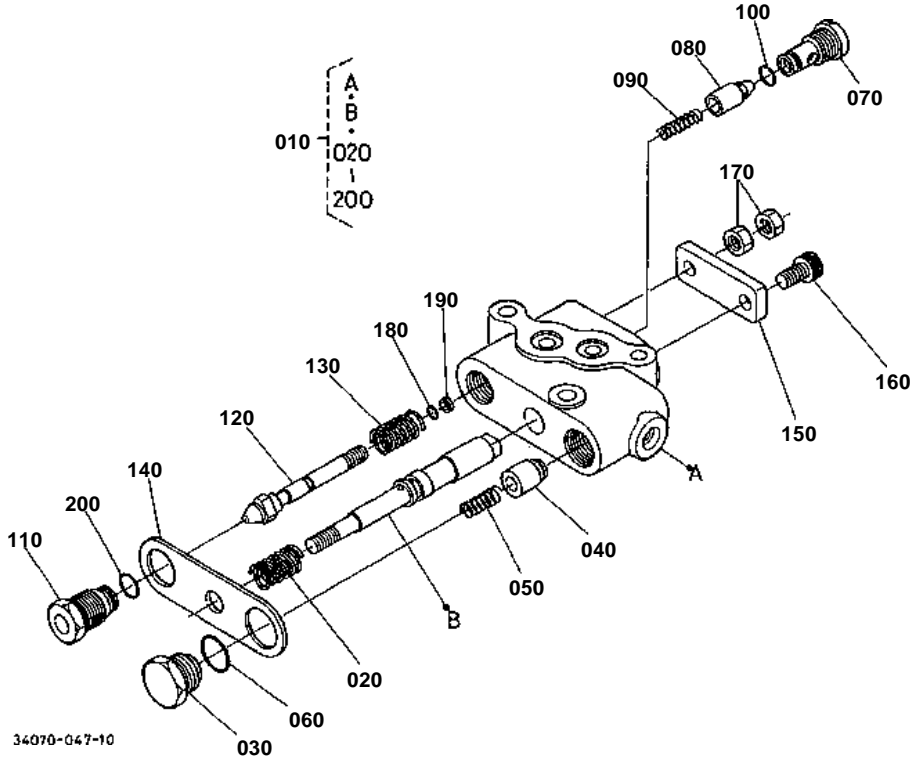

**CONTROL VALVE [COMPONENT PARTS]**

↔ Interchangeable; ≠ not interchangeable; ← new for old; → old for new

REF.No	Part No.	Description	Q'ty	S.No.	I/C	REMARKS	Weight (kgf)	Weight (lb)
010	35080-39100	ASSY VALVE CONTROL	1	<=62269		NOT SALE	1.6	3.52
010	35080-39102	ASSY VALVE CONTROL	1	>=62270	-		1.7	3.74
020	31351-39130	SPRING SPOOL	1				0.005	0.011
030	31351-39140	PLUG	1				0.05	0.11
040	35080-39150	POPPET	1				0.02	0.044
050	67531-38470	SPRING	1				0.001	0.0022
060	04811-00160	O RING	1				0	0
060	04817-00160	O RING	1		-		0.001	0.0022
070	35080-39170	PLUG	1				0.035	0.077
080	31391-39180	POPPET	1				0.015	0.033
090	31391-39190	SPRING	1				0.001	0.0022
100	04810-00090	O RING	1				0	0
100	04817-00090	O RING	1		-		0.001	0.0022
110	35080-39200	PLUG	1				0.04	0.088
120	35080-39220	POPPET	1				0.035	0.077
130	31351-39230	SPRING	1				0.008	0.0176
140	31351-39240	PLATE	1				0.05	0.11
150	35080-39250	PLATE JOINT	1				0.045	0.099
160	01311-10814	BOLT HEX-SOC-HD	1				0.012	0.0264
170	02112-50080	NUT	2				0.003	0.0066
180	04811-00050	O RING	1				0	0
180	04816-00050	O RING	1		-		0.001	0.0022
190	31351-39290	RING BACK UP	1				0.001	0.0022
200	04810-06100	O RING	1				0	0
200	04817-06100	O RING	1		-		0.001	0.0022

POSITION CONTROL LEVER

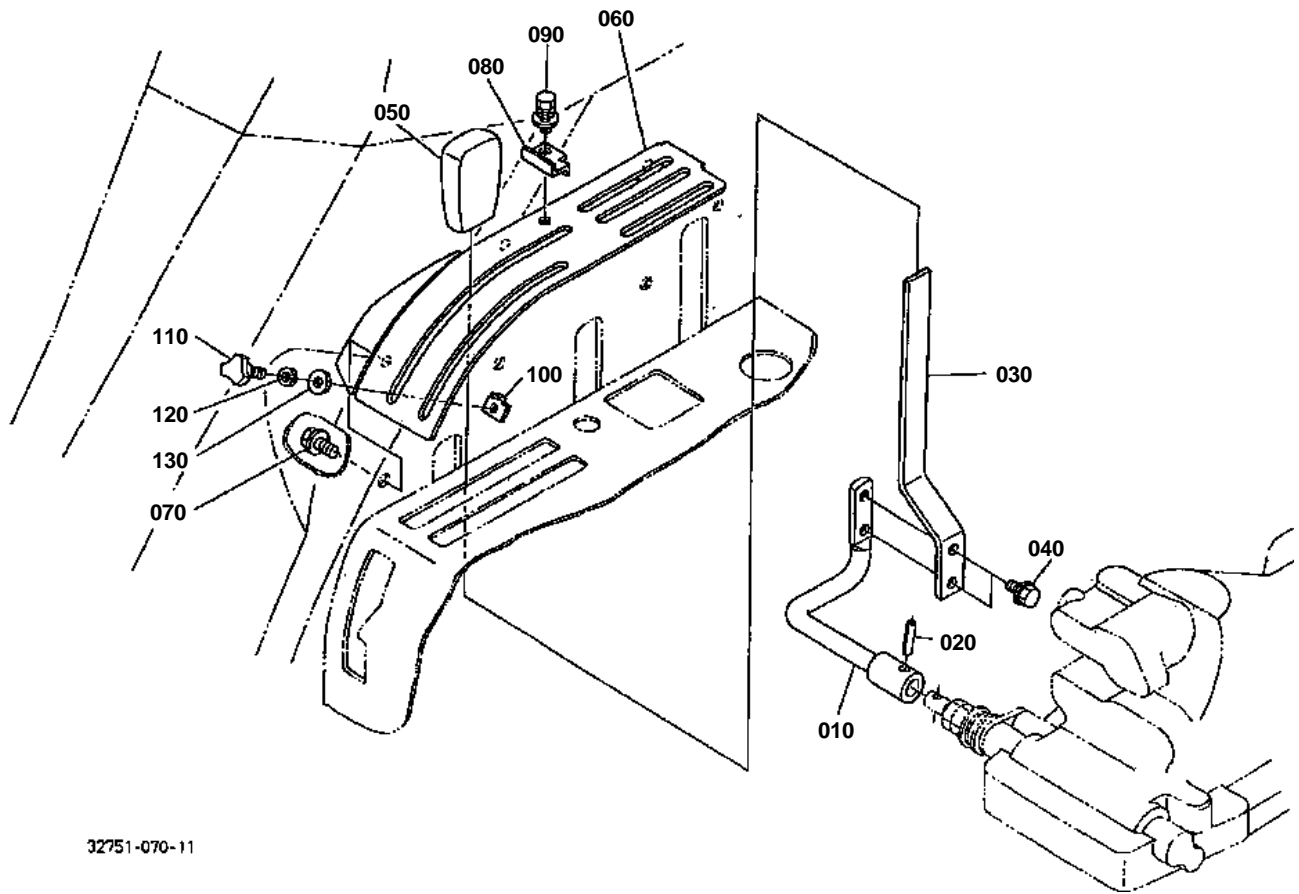

32751-070-11



POSITION CONTROL LEVER

↔ Interchangeable; ≠ not interchangeable; ← new for old; → old for new

REF.No	Part No.	Description	Q'ty	S.No.	I/C	REMARKS	Weight (kgf)	Weight (lb)
010	TA040-36110	LEVER POSITION	1				0.276	0.6072
020	05411-00525	PIN SPRING	1				0.002	0.0044
030	32751-36120	LEVER POSITION	1				0.19	0.418
040	01754-50616	BOLT FLANGE	2				0.006	0.0132
050	52300-32640	GRIP LEVER	1				0.04	0.088
060	32751-47600	GUIDE HYD.LEVER	1				0.495	1.089
070	01754-50812	BOLT FLANGE	1				0.01	0.022
070	01754-50816	BOLT FLANGE	1		«		0.011	0.0242
080	34070-36130	STOPPER	1				0.015	0.033
090	01125-60816	BOLT	1				0.01	0.022
100	34070-36140	STOPPER	1				0.005	0.011
100	T1060-36170	STOPPER	1		«		0.005	0.011
110	01820-50620	BOLT KNOB	1				0.015	0.033
110	37410-52610	BOLT KNOB	1		«		0.015	0.033
120	04512-50060	WASHER SPRING	1				0	0
130	31351-18860	WASHER	1				0.002	0.0044

FEED BACK LEVER

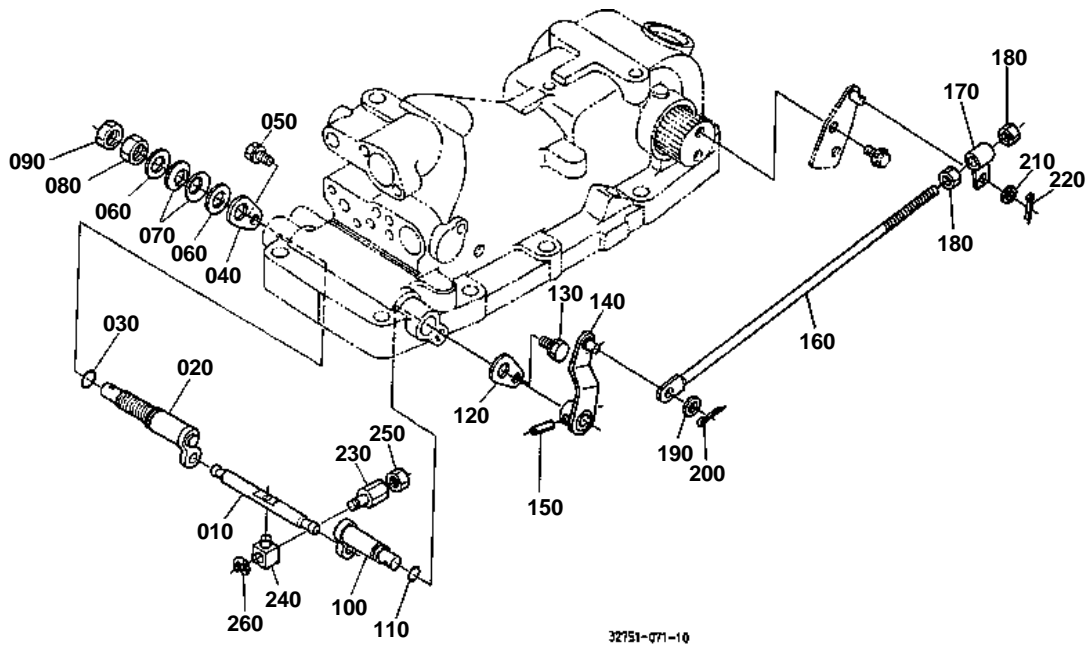

32751-071-10



FEED BACK LEVER

↔ Interchangeable; ≠ not interchangeable; ← new for old; → old for new

REF.No	Part No.	Description	Q'ty	S.No.	I/C	REMARKS	Weight (kgf)	Weight (lb)
010	31351-37640	LEVER SPOOL DRIVE	1				0.05	0.11
020	31351-37650	ARM CONTROL	1				0.16	0.352
030	04811-00140	O RING	1				0	0
030	04816-00140	O RING	1		→		0.002	0.0044
040	31351-37660	SET PLATE	1				0.01	0.022
050	01123-50816	BOLT	1				0	0
060	04013-50140	WASHER PLAIN	2				0	0
070	34260-36880	SPRING PLATE	2				0.006	0.0132
080	02174-50140	NUT	1				0.014	0.0308
090	02172-50140	NUT	1				0.01	0.022
100	31351-37750	SHAFT BACK LEVER	1				0.1	0.22
110	04811-00120	O RING	1				0	0
110	04816-00120	O RING	1		→		0.001	0.0022
120	38240-36890	SET PLATE	1				0.013	0.0286
130	01123-50816	BOLT	1				0	0
140	31351-37760	LEVER FEED BACK	1				0.08	0.176
150	05411-00525	PIN SPRING	1				0.002	0.0044
160	31321-37770	ROD FEEDBACK	1				0.12	0.264
170	31351-37780	ROD CONTROL	1				0.03	0.066
180	02114-50080	NUT	2				0.005	0.011
190	04013-50080	WASHER PLAIN	1				0	0
200	05511-50218	PIN SPLIT	1				0.001	0.0022
210	04013-50080	WASHER PLAIN	1				0	0
220	05511-50215	PIN SPLIT	1				0.001	0.0022
230	67531-38280	JOINT SPOOL	1				0.17	0.374
240	37150-36420	JOINT SPOOL	1				0.02	0.044
250	02112-50080	NUT	1				0.003	0.0066
260	04613-00060	CIRCLIP EXTERNAL	1				0	0

DIRECTIONAL VALVE LEVER

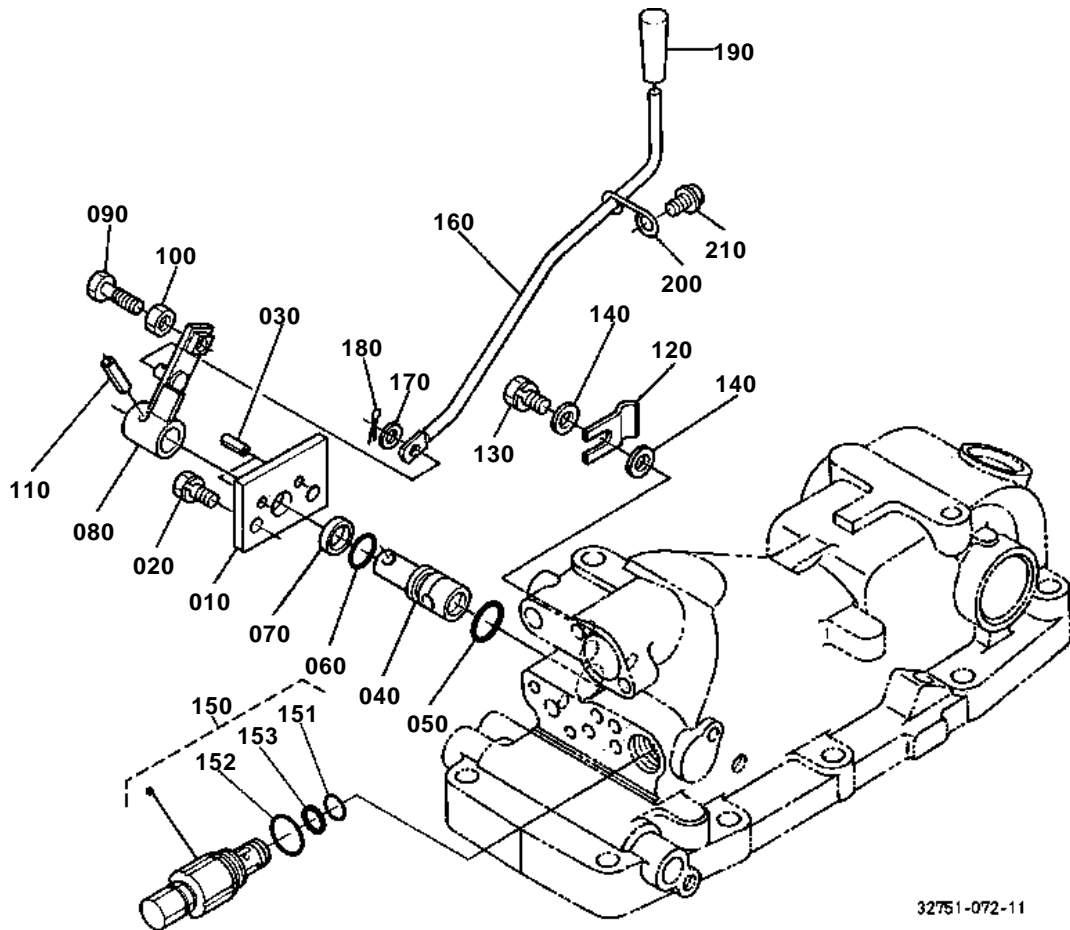

32751-072-11



DIRECTIONAL VALVE LEVER

↔ Interchangeable; ≠ not interchangeable; ← new for old; → old for new

REF.No	Part No.	Description	Q'ty	S.No.	I/C	REMARKS	Weight (kgf)	Weight (lb)
010	32751-36630	PLATE	1				0.115	0.253
020	01123-50820	BOLT	2				0.011	0.0242
030	05411-00414	PIN SPRING	2				0.001	0.0022
040	32751-36910	SPOOL HYD.CHANGE	1				0.06	0.132
050	04810-00180	O RING	1				0	0
050	04817-00180	O RING	1		«		0.003	0.0066
060	04810-00140	O RING	1				0	0
060	04817-00140	O RING	1		«		0.001	0.0022
070	34076-66250	RING BACK UP	1				0.005	0.011
080	32751-36920	LEVER	1				0.063	0.1386
090	01053-50625	BOLT	1				0.007	0.0154
100	02012-50060	NUT	1				0	0
110	05411-00425	PIN SPRING	1				0.001	0.0022
120	38430-17180	SPRING	2				0.1	0.22
130	01023-50612	BOLT	1				0.005	0.011
140	04013-50060	WASHER PLAIN	1				0	0
150	32751-37900	ASSY VALVE RELIEF	1				0.255	0.561
151	04811-05150	O RING	1				0	0
151	04816-05150	O RING	1		«		0.002	0.0044
152	04811-00220	O RING	1				0	0
152	04816-00220	O RING	1		«		0.003	0.0066
153	36330-82370	RING BACK UP	1				0.001	0.0022
160	32751-36940	ROD	1				0.165	0.363
170	04013-50060	WASHER PLAIN	1				0	0
180	05511-51615	PIN SPLIT	1				0.001	0.0022
190	31391-18560	GRIP LEVER	1				0.01	0.022
200	32751-36950	GUIDE HYD.LEVER	1				0.005	0.011
210	01754-50816	BOLT FLANGE	1				0.011	0.0242
210	01754-50812	BOLT FLANGE	1		«		0.01	0.022

3-POINT LINKAGE 1 (LOWER LINK)

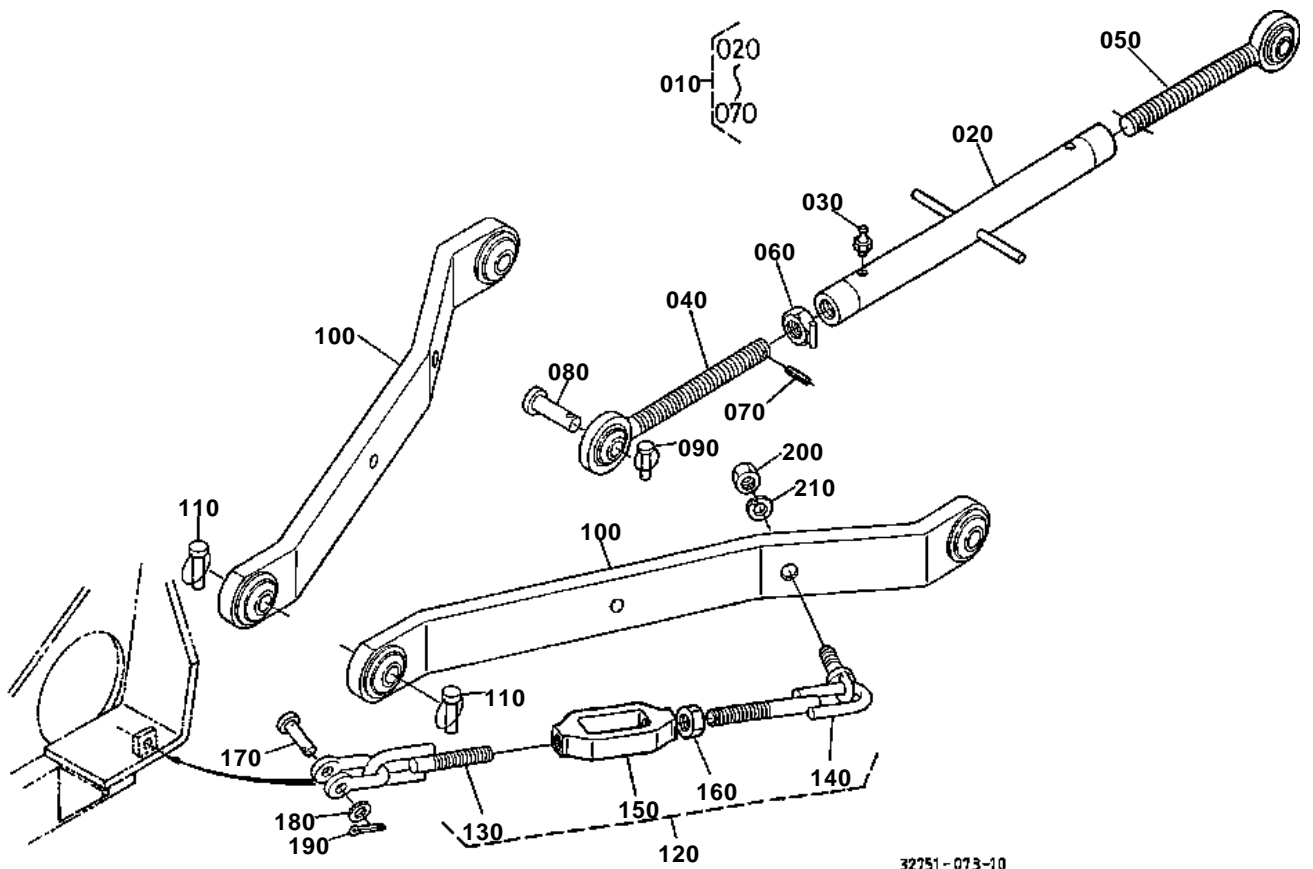

32751-073-10



3-POINT LINKAGE 1 (LOWER LINK)

↔ Interchangeable; ≠ not interchangeable; ← new for old; → old for new

REF.No	Part No.	Description	Q'ty	S.No.	I/C	REMARKS	Weight (kgf)	Weight (lb)
010	35240-71103	ASSY LINK TOP	1				3.3	7.26
020	35240-71113	LINK TOP	1				1.24	2.728
030	67211-42940	NIPPLE GREASE	2				0.001	0.0022
040	35240-71210	JOINT TOP LINK	1				0.96	2.112
050	35240-71220	JOINT TOP LINK	1				0.965	2.123
060	32244-71180	NUT TOP LINK	1				0.057	0.1254
070	05411-00430	PIN SPRING	2				0.002	0.0044
080	31150-71360	PIN JOINT	2				0.166	0.3652
090	34150-37640	PIN SET	2				0.06	0.132
100	32751-71310	COMP.LINK LOWER	2				7.6	16.72
110	34150-37640	PIN SET	4				0.06	0.132
120	32751-71800	ASSY CHAIN CHECK	2	<=73720			1.565	3.443
120	32751-71802	ASSY CHAIN CHECK	2	>=73721	-		0	0
130	31351-71810	JOINT CHAIN	2	<=73720			0	0
130	31351-71813	JOINT CHAIN	2	>=73721	-		0	0
140	32751-71820	JOINT CHAIN	2	<=73720			0.53	1.166
140	32751-71822	JOINT CHAIN	2	>=73721	-		0	0
150	32430-71840	TURNBUCKLE	2	<=73720			0	0
150	32430-71842	TURNBUCKLE	2	>=73721	-		0	0
160	02052-50160	NUT	2				0.025	0.055
170	32353-71890	PIN	2				0.041	0.0902
180	04013-60120	WASHER PLAIN	2				0.01	0.022
190	05511-50425	PIN SPLIT	2				0.003	0.0066
200	02074-50160	NUT	2				0.029	0.0638
210	04512-60160	WASHER SPRING	2				0.01	0.022

3-POINT LINKAGE 2 (LIFT ROD)

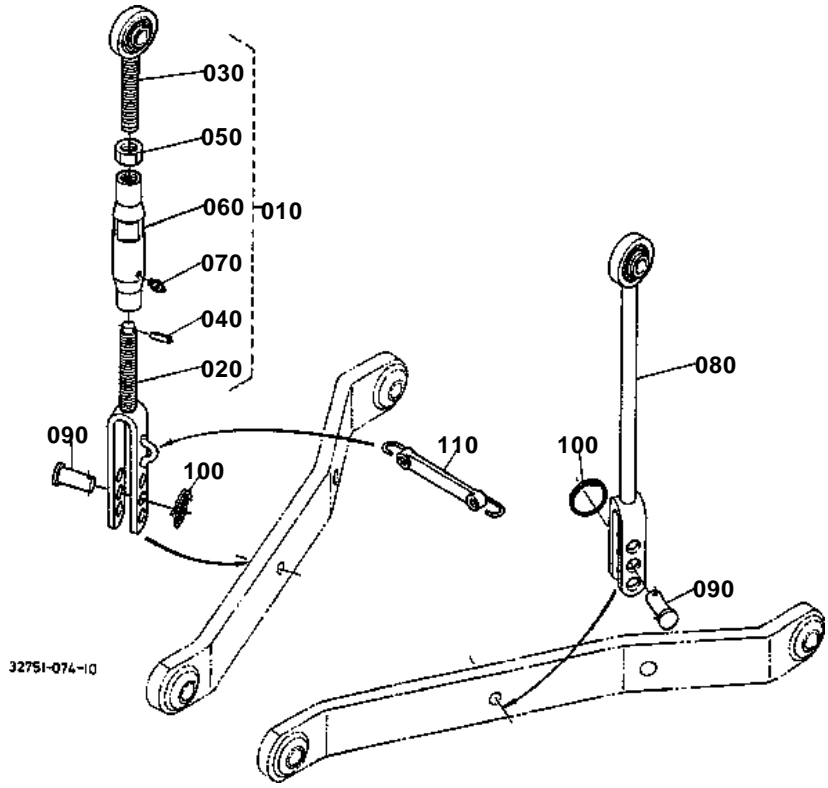



3-POINT LINKAGE 2 (LIFT ROD)

↔ Interchangeable; ≠ not interchangeable; ← new for old; → old for new

REF.No	Part No.	Description	Q'ty	S.No.	I/C	REMARKS	Weight (kgf)	Weight (lb)
010	32751-71560	ASSY ROD LIFT RH	1				1.98	4.356
020	35080-71520	ROD LIFT LOWER	1				0.88	1.936
030	31331-71510	ROD LIFT UPPER	1				0.58	1.276
040	05411-00320	PIN SPRING	1				0.001	0.0022
050	35110-71570	NUT	1				0.05	0.11
060	32751-39350	TURNBUCKLE	1				0.485	1.067
070	06613-10675	NIPPLE GREASE	1				0.003	0.0066
080	35080-71540	ROD LIFT LH	1				1.6	3.52
090	38747-71582	PIN LIFT ROD	2				0.1	0.22
100	67156-34340	RING SNAP	2				0.01	0.022
110	35080-71750	COMP.RUBBER	1				0.065	0.143

TOP LINK HOLDER AND PTO PROTECTOR

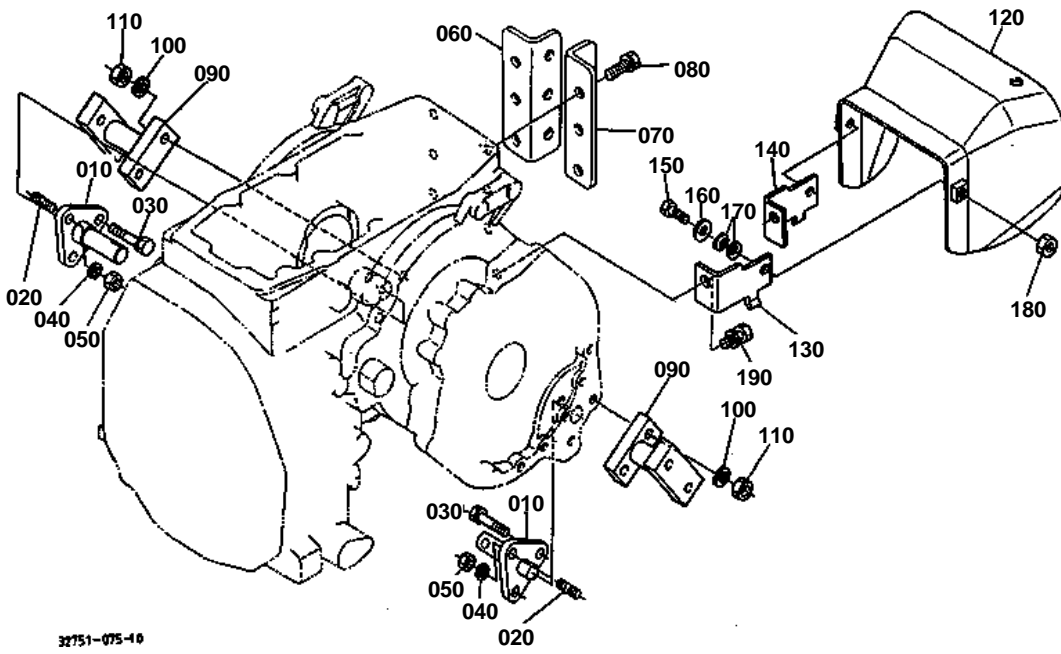

120 TA040-2374-0

130 TA040-2375-0

140 TA040-2376-0

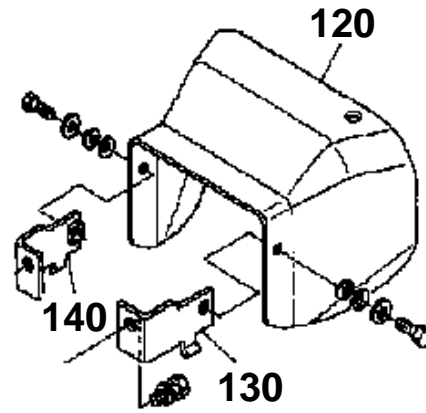

32751-800-10



TOP LINK HOLDER AND PTO PROTECTOR

↔ Interchangeable; ≠ not interchangeable; ← new for old; → old for new

REF.No	Part No.	Description	Q'ty	S.No.	I/C	REMARKS	Weight (kgf)	Weight (lb)
010	34070-39410	HOLDER LOWER LINK	2	<=73398			0	0
010	34070-39412	HOLDER LOWER LINK	2	>=73399	→		0.505	1.111
020	01517-51020	STUD	2	<=72318			0.019	0.0418
020	01517-61022	STUD	2	>=72319	1		0.019	0.0418
030	01175-51060	BOLT	4				0.04	0.088
030	01133-51025	BOLT	4		«		0.023	0.0506
040	04512-50100	WASHER SPRING	2				0	0
050	02176-50100	NUT	2				0.005	0.011
060	99571-22140	HOLDER TOP LINK RH	1				0.96	2.112
070	99571-22150	HOLDER TOP LINK LH	1				0.99	2.178
080	01133-51230	BOLT	6				0.04	0.088
090	32751-39420	BRACKET	2				0.56	1.232
100	04512-50100	WASHER SPRING	4				0	0
110	02176-50100	NUT	4				0.005	0.011
120	TA040-23740	PROTECTOR PTO	1	<=50100		NOT SALE	2.1	4.62
120	TA040-23742	PROTECTOR PTO	1	>=50101	1		2.1	4.62
130	TA040-23750	STAY	1	<=50100			0.2	0.44
130	TA040-23752	STAY	1	>=50101	1		0.19	0.418
140	TA040-23760	STAY	1	<=50100			0.2	0.44
140	TA040-23762	STAY	1	>=50101	1		0.19	0.418
150	01173-51025	BOLT	2				0.021	0.0462
160	04013-50100	WASHER PLAIN	2				0	0
170	62151-42412	SPRING	4				0.002	0.0044
180	02116-50100	NUT	2				0.004	0.0088
190	01133-51230	BOLT	2				0.04	0.088

FRONT GRILLE

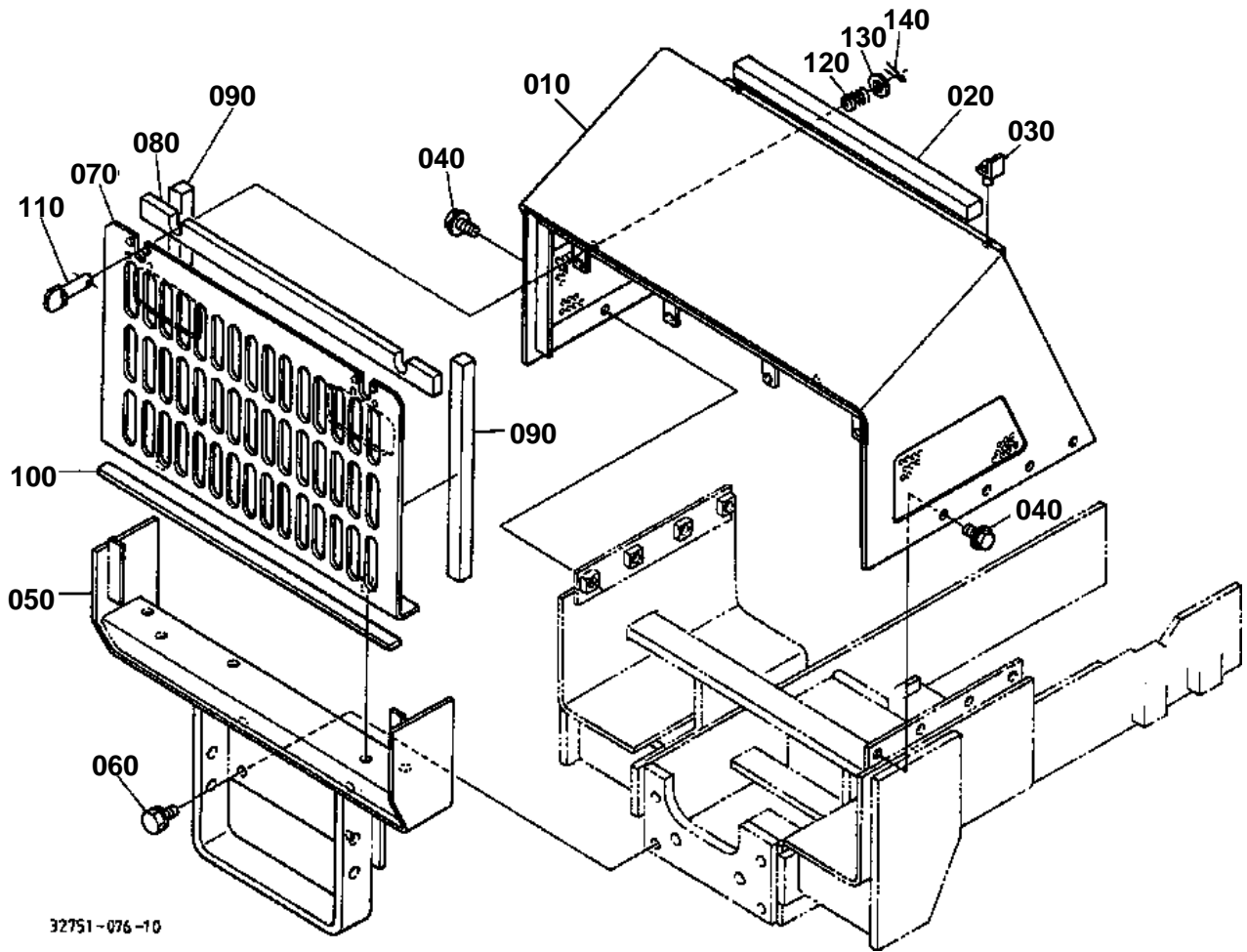

32751-076-10



FRONT GRILLE

↔ Interchangeable; ≠ not interchangeable; ← new for old; → old for new

REF.No	Part No.	Description	Q'ty	S.No.	I/C	REMARKS	Weight (kgf)	Weight (lb)
010	32751-41010	HOOD FRONT GRILLE	1				12.8	28.16
020	32751-41060	CUSHION	1	<=71191			0.045	0.099
020	32771-41060	CUSHION	1	>=71192	↔		0.045	0.099
030	32530-18730	CUSHION BONNET	2	<=50497			0.005	0.011
030	32751-41100	CUSHION	2	>=50498	↔		0.005	0.011
040	01774-61020	BOLT FLANGE	8				0.022	0.0484
050	32751-41020	SUPPORT FRONT GRILLE	1				10.9	23.98
060	01133-51225	BOLT	4				0.035	0.077
070	32751-41830	GRILLE FRONT	1				3.5	7.7
080	32751-41110	SPONGE	1				0.015	0.033
090	32751-41120	SPONGE	2				0.008	0.0176
100	32751-41130	CUSHION	1	<=50497			0	0
100	32751-41132	CUSHION	1	>=50498	↔		0	0
100	32771-41130	CUSHION	1		↔		0.025	0.055
110	32751-41850	PIN	2				0.062	0.1364
120	31305-24990	SPRING	2				0.01	0.022
130	04011-50100	WASHER PLAIN	2				0.002	0.0044
140	05511-50318	PIN SPLIT	2				0.001	0.0022

HOOD (BONNET) AND SIDE COVER

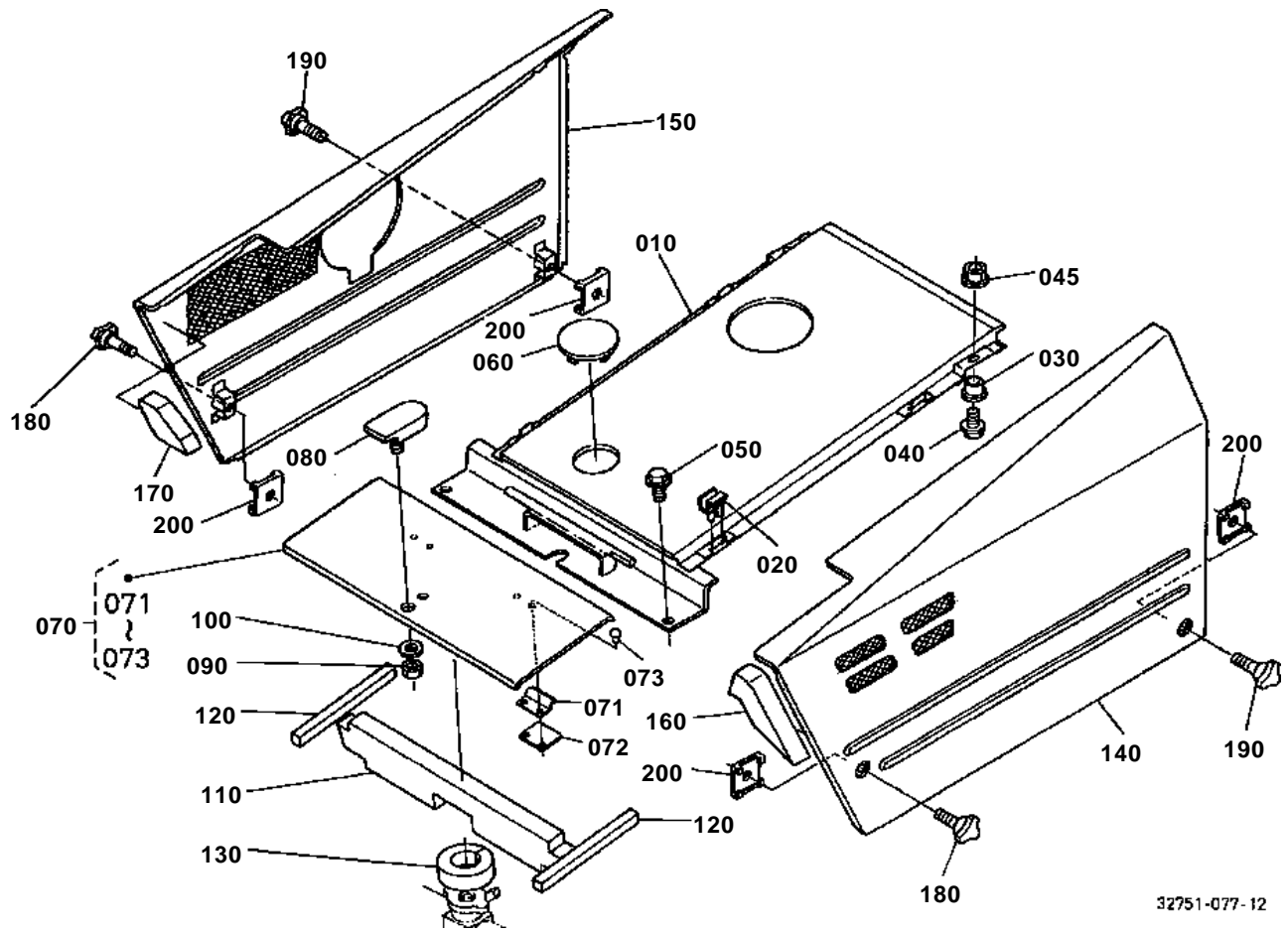

020 30442-1862-5

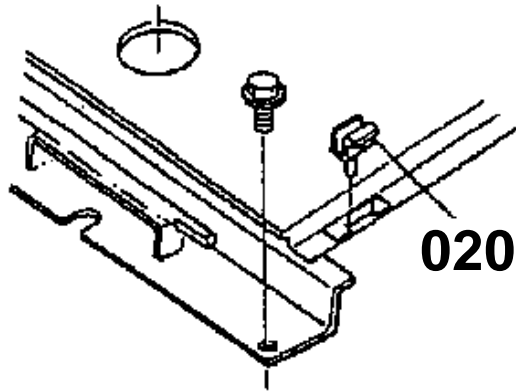

200 35533-8330-0

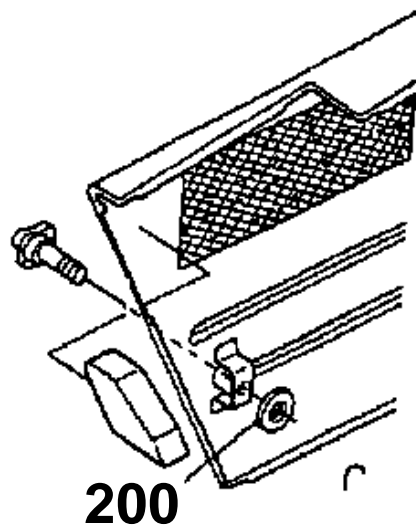

32751-810-10



HOOD (BONNET) AND SIDE COVER

↔ Interchangeable; ≠ not interchangeable; ← new for old; → old for new

REF.No	Part No.	Description	Q'ty	S.No.	I/C	REMARKS	Weight (kgf)	Weight (lb)
010	32751-41310	COMP.BONNET	1	<=60599			0	0
010	32751-41314	COMP.BONNET	1	>=60600	↔		4.62	10.164
020	30442-18625	CUSHION	4	<=60599			0.005	0.011
020	TA040-18620	CUSHION	4	>=60600	↔		0.01	0.022
030	34070-41630	CUSHION	2				0.005	0.011
040	01754-50820	BOLT FLANGE	2				0.015	0.033
045	02751-50080	NUT FLANGE	2				0.006	0.0132
050	01774-61020	BOLT FLANGE	2				0.022	0.0484
060	32480-18760	CAP PRE CLEANER	1				0.02	0.044
070	32751-41330	COVER RADIATOR	1				2.5	5.5
071	30400-94080	SPRING BONNET COVER	2				0.012	0.0264
072	30400-94092	SPRING BONNET COVER	2				0.015	0.033
073	05611-10612	RIVET	4				0.005	0.011
080	34550-41380	HOOK BONNET	1				0.04	0.088
090	02114-50080	NUT	1				0.005	0.011
100	04015-60080	WASHER PLAIN	1				0.01	0.022
110	32751-41160	SPONGE	1				0.026	0.0572
120	32751-41340	SPONGE	2				0.005	0.011
130	32751-41150	SPONGE	1				0.006	0.0132
140	32751-41410	COVER SIDE LH	1	<=50297			0	0
140	32751-41413	COVER SIDE LH	1	>=50298	↔		3.95	8.69
150	32751-41420	COVER SIDE RH	1	<=50297			0	0
150	32751-41423	COVER SIDE RH	1	>=50298	↔		3.65	8.03
160	32751-41440	SPONGE	1				0.01	0.022
170	32751-41470	SPONGE	1				0.005	0.011
180	01820-50835	BOLT KNOB	2				0.03	0.066
190	01820-50840	BOLT KNOB	2				0.03	0.066
200	35533-83300	CUSHION	4	<=60285			0.001	0.0022
200	32751-41490	CUSHION	4	>=60286	↔		0.002	0.0044

SHUTTER PLATE

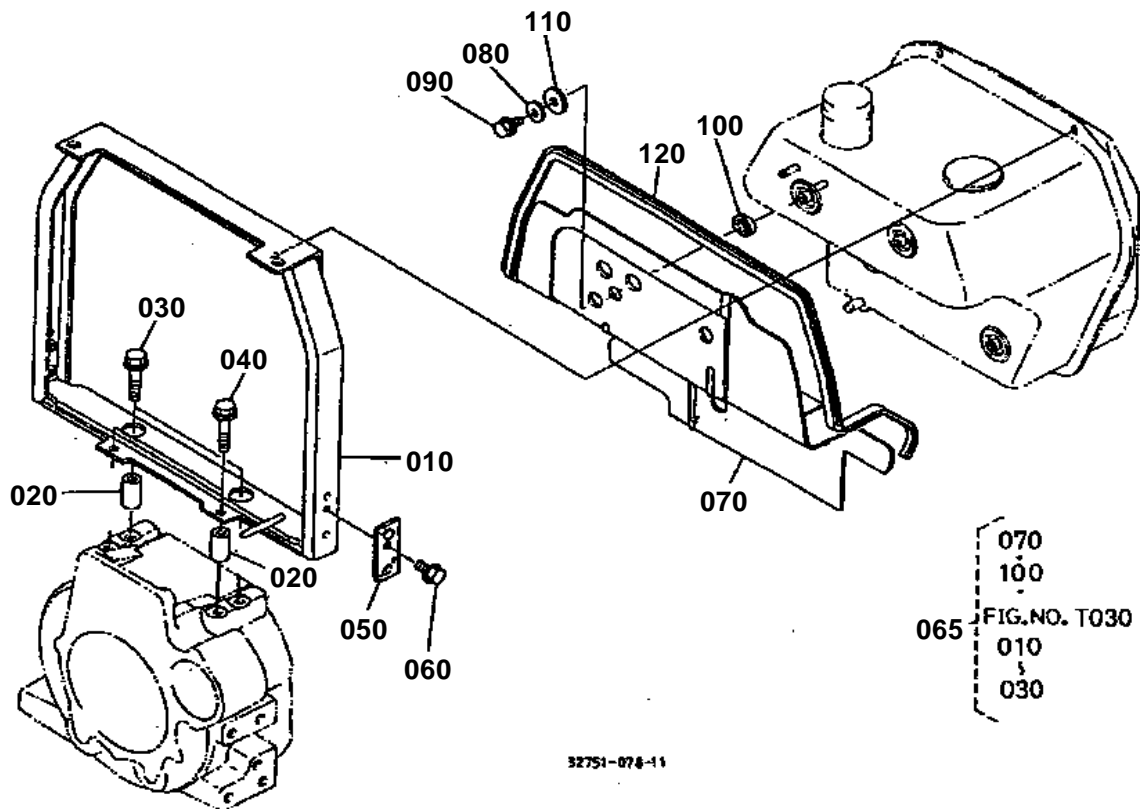

070 32751-4211-0

070

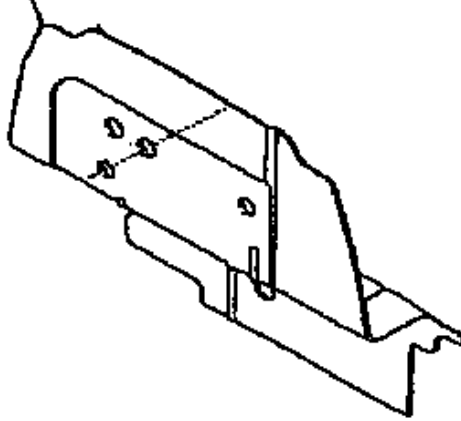

32751-818-10



SHUTTER PLATE

↔ Interchangeable; ≠ not interchangeable; ← new for old; → old for new

REF.No	Part No.	Description	Q'ty	S.No.	I/C	REMARKS	Weight (kgf)	Weight (lb)
010	34070-75010	SUPPORT BONNET REAR	1	<=61536			0	0
010	34070-75014	SUPPORT BONNET REAR	1	>=61537	↔		4.3	9.46
020	34070-42140	SPACER	4				0.065	0.143
020	T0270-42140	SPACER	4		«		0.056	0.1232
030	01779-51060	BOLT UBS	2				0.005	0.011
040	01774-51060	BOLT FLANGE	2				0.04	0.088
050	32751-42360	SPACER	1				0.093	0.2046
060	01754-50816	BOLT FLANGE	1				0.011	0.0242
065	32751-94400	KIT FUEL TANK	1	<=72038			9.9	21.78
070	32751-42110	PLATE SHUTTER	1	<=72038		NOT SALE ORDER BY REF.No.065	3.1	6.82
070	32751-42112	PLATE SHUTTER	1	>=72039	↔		3.1	6.82
080	04015-50080	WASHER PLAIN	4				0	0
090	01754-50812	BOLT FLANGE	4				0.01	0.022
100	34070-42260	CUSHION	4				0.005	0.011
110	34070-42270	CUSHION	4				0.005	0.011
120	34070-42220	SHIELD	1	<=64749			0	0
120	34070-42223	SHIELD	1	>=64750	↔		0.33	0.726

PANEL FRAME

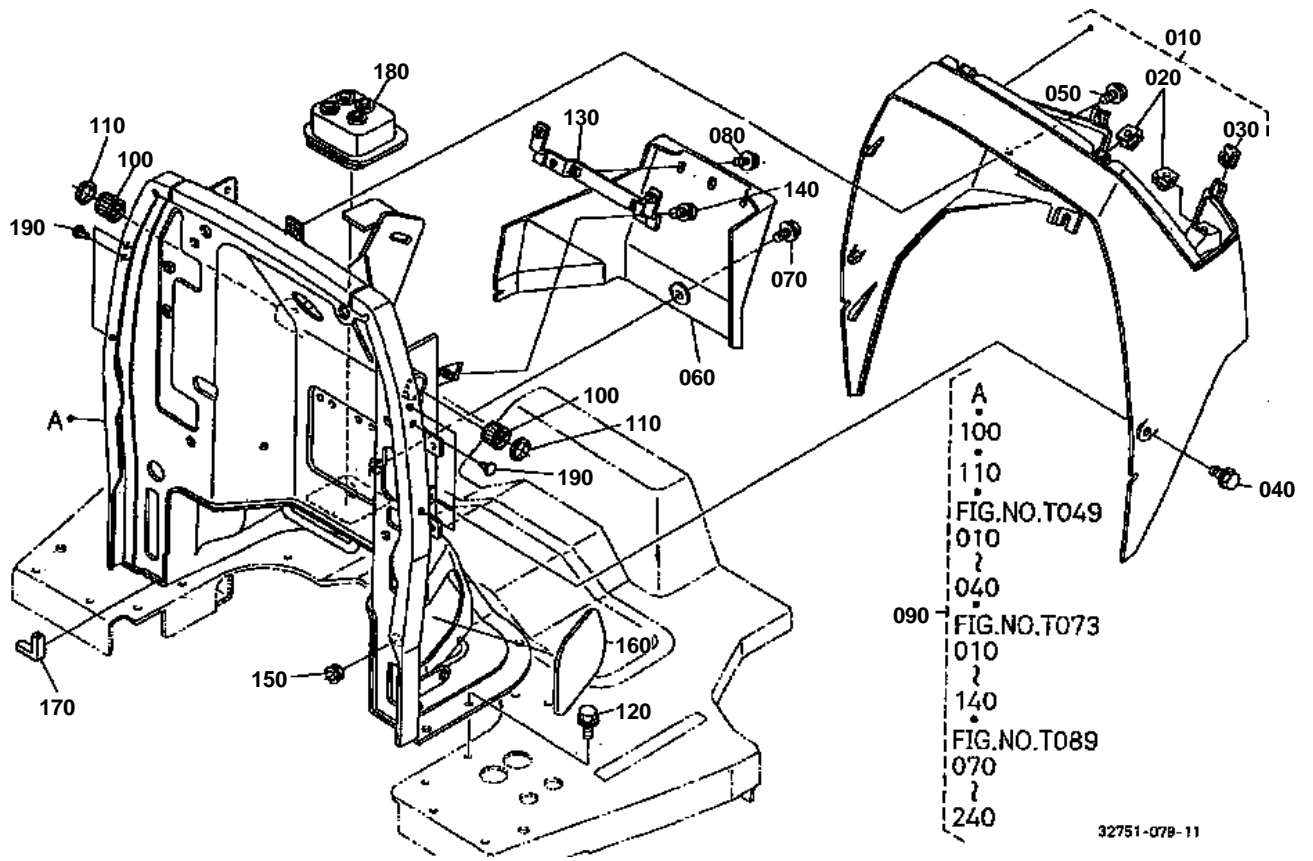



PANEL FRAME

↔ Interchangeable; ≠ not interchangeable; ← new for old; → old for new

REF.No	Part No.	Description	Q'ty	S.No.	I/C	REMARKS	Weight (kgf)	Weight (lb)
010	34070-43010	BONNET	1				2	4.4
020	34070-99160	NUT SPRING	4				0.005	0.011
030	37410-54930	NUT SPRING	2				0.025	0.055
040	30400-18870	BOLT FLANGE	4				0.01	0.022
050	01754-50816	BOLT FLANGE	1				0.011	0.0242
060	34070-43032	COVER	1				0.28	0.616
070	30400-18870	BOLT FLANGE	1				0.01	0.022
080	30400-19060	BOLT FLANGE	2				0.006	0.0132
090	32751-43200	ASSY FRAME PANEL	1	<=60815			23.5	51.7
090	32751-43203	ASSY FRAME PANEL	1	>=60816	-		0	0
090	32751-43207	ASSY FRAME PANEL	1	>=63504	-		23.5	51.7
100	34070-44360	BEARING NEEDLE	2				0.012	0.0264
110	34070-44140	SEAL OIL	2				0.005	0.011
120	01754-50816	BOLT FLANGE	8				0.011	0.0242
130	34550-43240	BRACKET PANEL COVER	1				0.135	0.297
140	01123-50816	BOLT	2				0	0
150	32150-29180	CAP RUBBER	1				0.002	0.0044
160	34070-43280	COVER PANEL FRAME	1				0.12	0.264
170	37150-13920	RUBBER PROTECTOR	1				0.005	0.011
180	34550-43335	GROMMET	1				0.06	0.132
190	38240-29570	PLUG	6	>=62733			0.001	0.0022

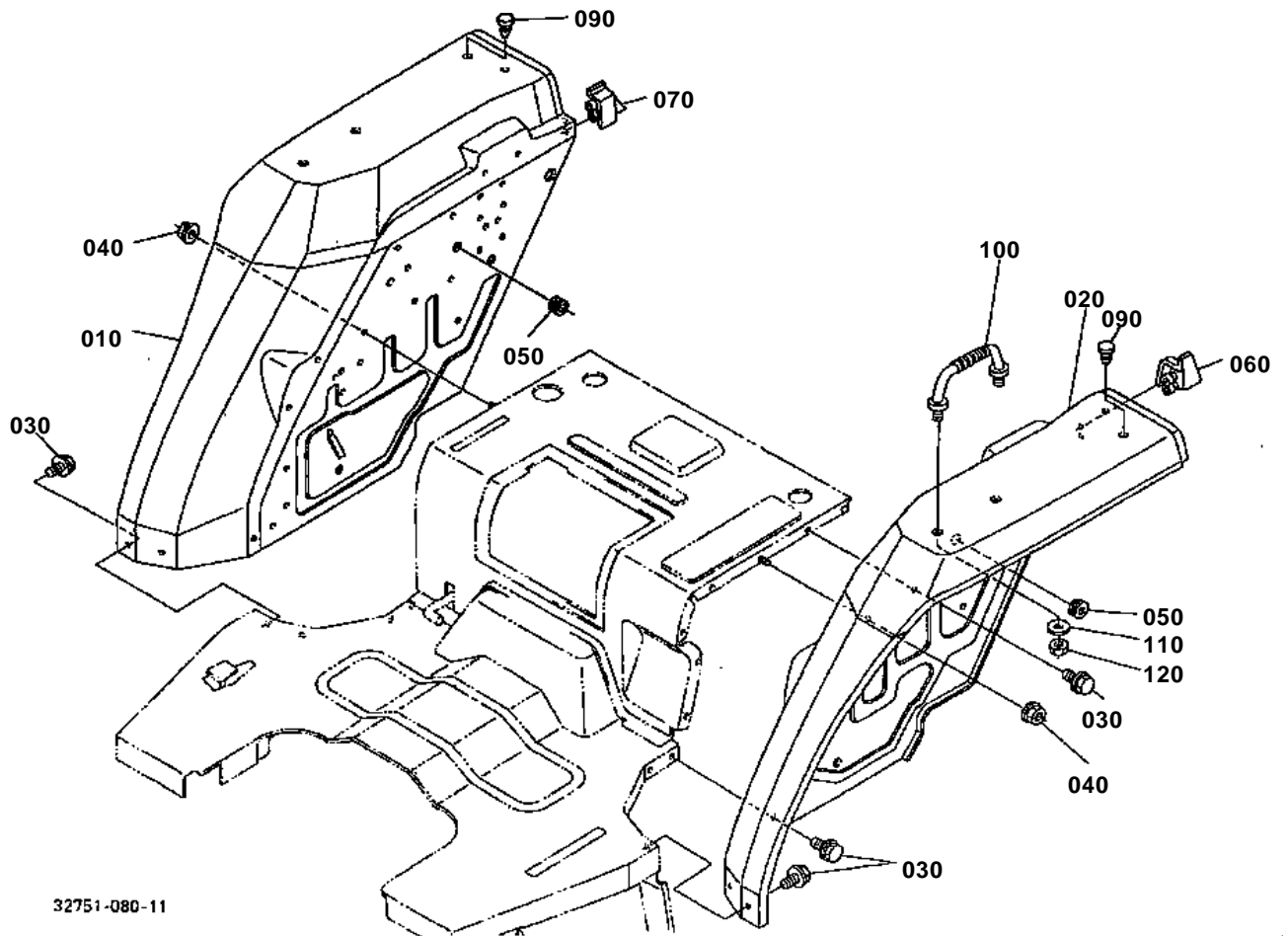

32751-080-11

060 34070-4706-0

070 34070-4707-0

080 31351-9355-0

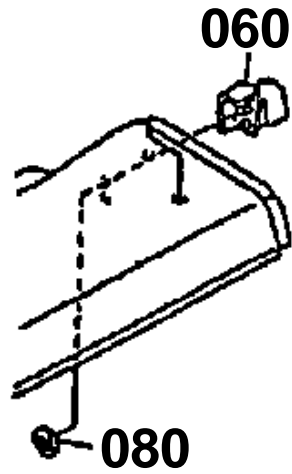
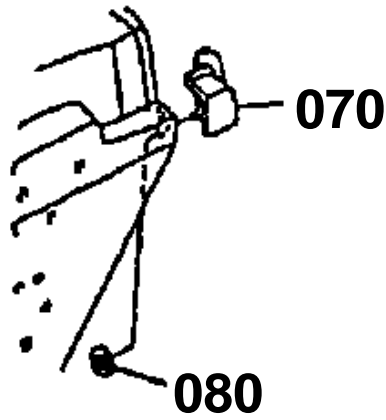

32751-825-10

**FENDER**

↔ Interchangeable; ≠ not interchangeable; ← new for old; → old for new

REF.No	Part No.	Description	Q'ty	S.No.	I/C	REMARKS	Weight (kgf)	Weight (lb)
010	32751-47000	FENDER RH	1				8	17.6
020	32751-47010	FENDER LH	1				8	17.6
030	01754-50812	BOLT FLANGE	28				0.01	0.022
040	02751-50080	NUT FLANGE	2				0.006	0.0132
050	32150-29180	CAP RUBBER	2				0.002	0.0044
060	34070-47060	PLATE FENDER LH	1	<=72556			0.025	0.055
060	34040-68980	PLATE FENDER LH	1	>=72557	1		0.02	0.044
070	34070-47070	PLATE FENDER RH	1	<=72556			0.025	0.055
070	34040-68990	PLATE FENDER RH	1	>=72557	1		0.025	0.055
080	31351-93550	NUT	4	<=72556			0.001	0.0022
090	30810-29170	PLUG	2				0.003	0.0066
100	34670-29440	HANDRAIL	1				0.1	0.22
110	04013-50140	WASHER PLAIN	2				0	0
120	02174-50140	NUT	2				0.014	0.0308

FLOOR SEAT

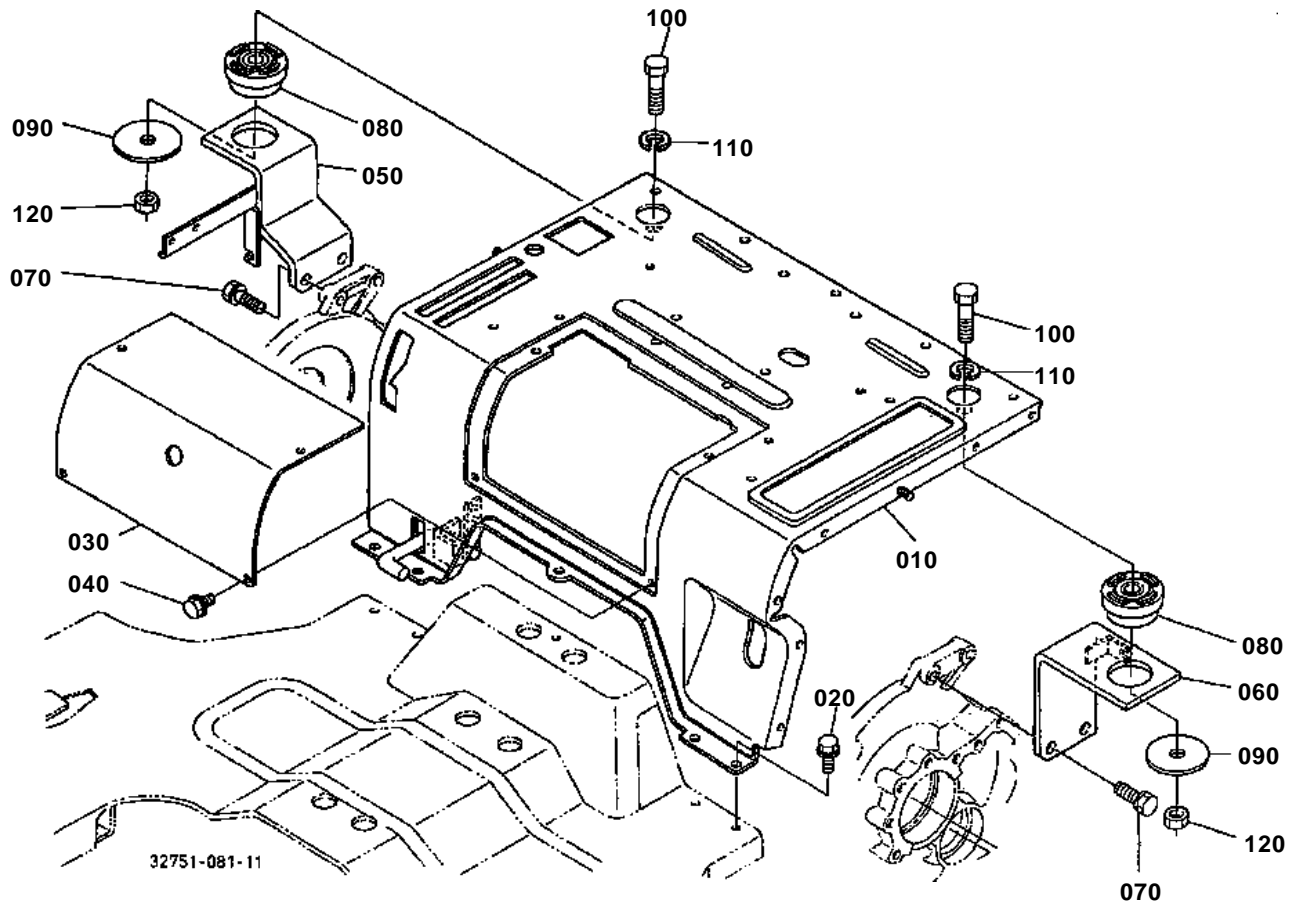

010 32751-4720-0

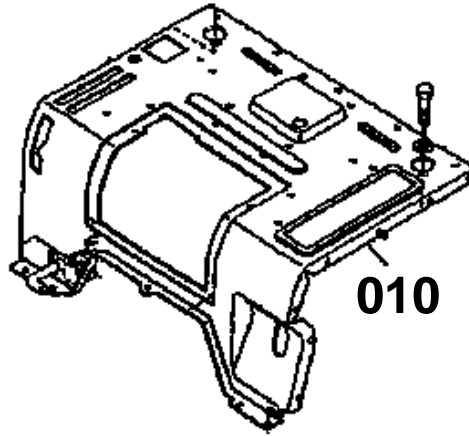

32751-829-10



FLOOR SEAT

↔ Interchangeable; ≠ not interchangeable; ← new for old; → old for new

REF.No	Part No.	Description	Q'ty	S.No.	I/C	REMARKS	Weight (kgf)	Weight (lb)
010	32751-47200	COVER FLOOR SEAT	1				0	0
010	32751-47204	COVER FLOOR SEAT	1		<<		7.5	16.5
020	01754-50812	BOLT FLANGE	5				0.01	0.022
030	34070-47280	COVER FLOOR SEAT	1				1.14	2.508
040	01754-50812	BOLT FLANGE	4				0.01	0.022
050	TA040-47210	SUPPORT FLOOR SEAT	1				1.55	3.41
060	TA040-47220	SUPPORT FLOOR SEAT	1				1.55	3.41
070	01133-51230	BOLT	4				0.04	0.088
080	34070-47310	CUSHION	2				0.165	0.363
090	34070-47320	WASHER	2				0.1	0.22
100	01173-51660	BOLT	2				0.114	0.2508
110	04512-50160	WASHER SPRING	2				0	0
120	02176-50160	NUT	2				0.021	0.0462

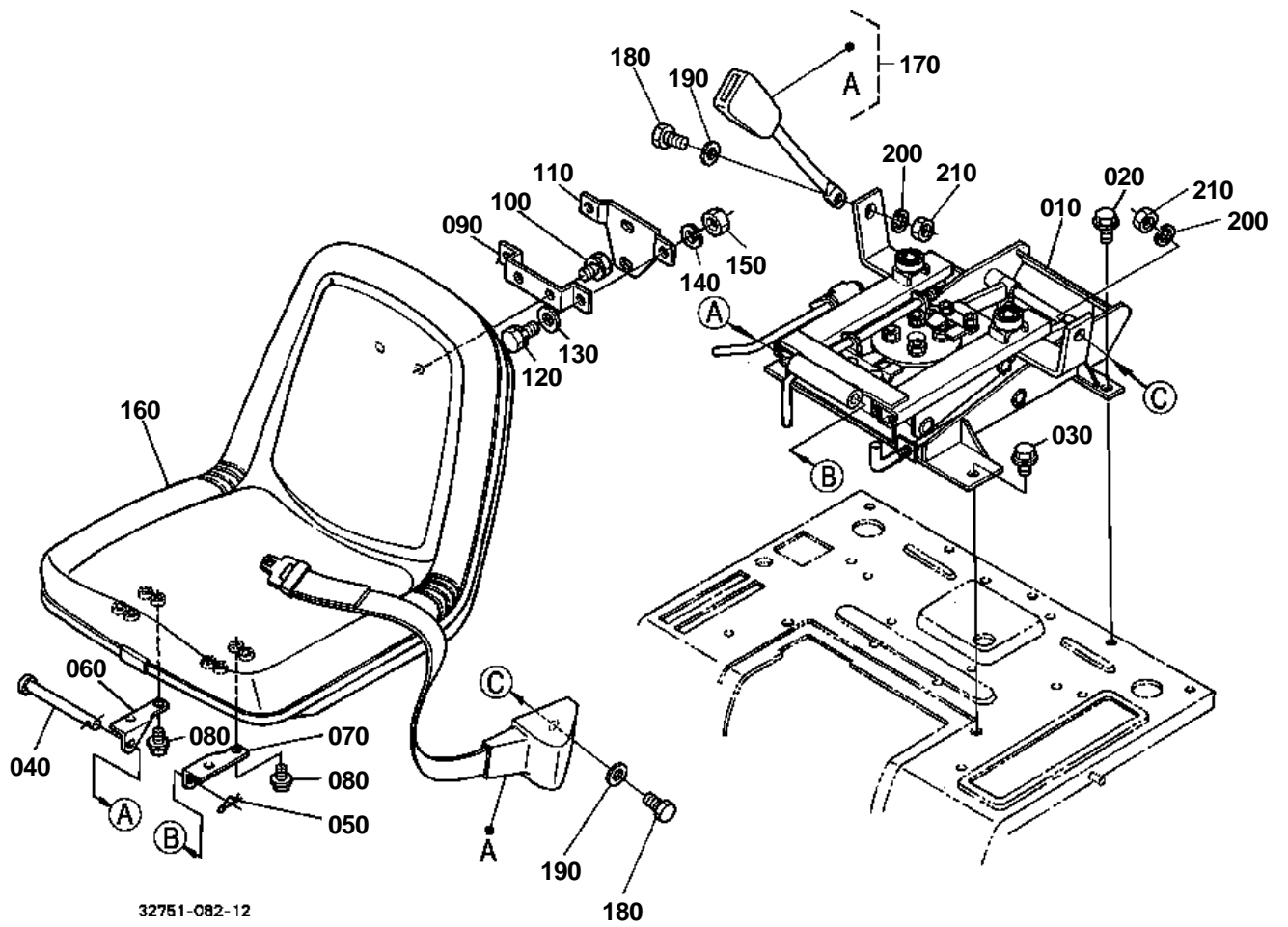

32751-082-12

010 32751-4774-6

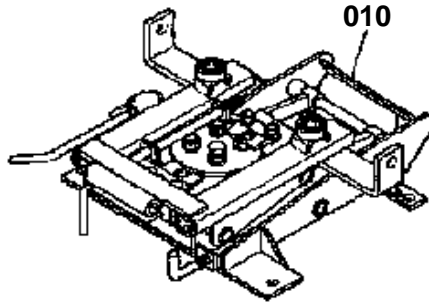

170 32751-1855-0

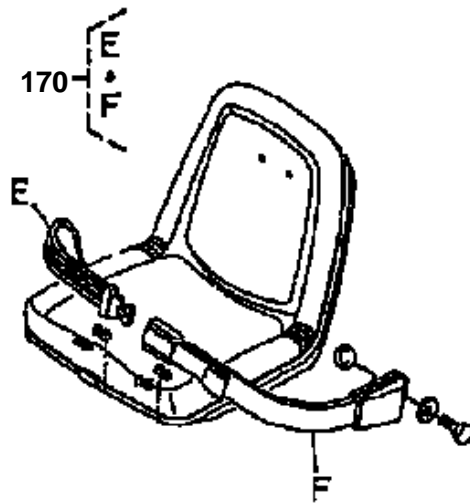

32751-826-11

**SEAT**

↔ Interchangeable; ≠ not interchangeable; ← new for old; → old for new

REF.No	Part No.	Description	Q'ty	S.No.	I/C	REMARKS	Weight (kgf)	Weight (lb)
010	32751-47740	BASE REVERSIBL SEAT	1	<=60504			0	0
010	32751-47743	BASE REVERSIBL SEAT	1	>=60505	↔		0	0
010	32751-47746	BASE REVERSIBL SEAT	1	>=64246	↔		0	0
010	32751-47747	BASE REVERSIBL SEAT	1	>=73825	↔		14.5	31.9
020	01754-50820	BOLT FLANGE	3				0.015	0.033
030	01774-61020	BOLT FLANGE	2				0.022	0.0484
040	32430-11853	PIN JOINT	1				0.08	0.176
050	05525-61000	PIN SNAP	1				0.002	0.0044
060	32430-18450	BRACKET SEAT RH	1				0.08	0.176
070	32430-18460	BRACKET SEAT LH	1				0.08	0.176
080	01754-50816	BOLT FLANGE	4				0.011	0.0242
090	67401-45922	STAY	1				0.08	0.176
100	01123-60816	BOLT	2				0.01	0.022
110	66704-54952	BRACKET SMV	1				0.15	0.33
120	01023-50618	BOLT	2				0.006	0.0132
130	04013-60060	WASHER PLAIN	2				0.001	0.0022
140	04512-60060	WASHER SPRING	2				0.001	0.0022
150	02014-50060	NUT	2				0.002	0.0044
160	35080-18400	ASSY SEAT	1				0	0
170	32751-18550	ASSY BELT SEAT	1	<=72041			0.8	1.76
170	6C040-72253	ASSY BELT SEAT	1	>=72042	↔		0.9	1.98
180	75599-04525	HEX.BOLT	2	<=72041			0.047	0.1034
180	75599-03325	HEX.BOLT	2	>=72042	↔		0.021	0.0462
190	75599-32015	WASHER PLAIN	2	<=72041			0.01	0.022
190	75599-32013	WASHER PLAIN	2	>=72042	↔		0.03	0.066
200	75599-33015	WASHER SPRING	2	<=72041			0.006	0.0132
200	75599-33013	WASHER SPRING	2	>=72042	↔		0.006	0.0132
200	0Y450-50060	WASHER SPRING	2		↔		0.003	0.0066
210	75599-31025	HEX.NUT	2	<=72041			0.015	0.033
210	75599-31913	NUT LOCKING	2	>=72042	↔		0.008	0.0176

REVERSIBLE SEAT BASE [COMPONENT PARTS]

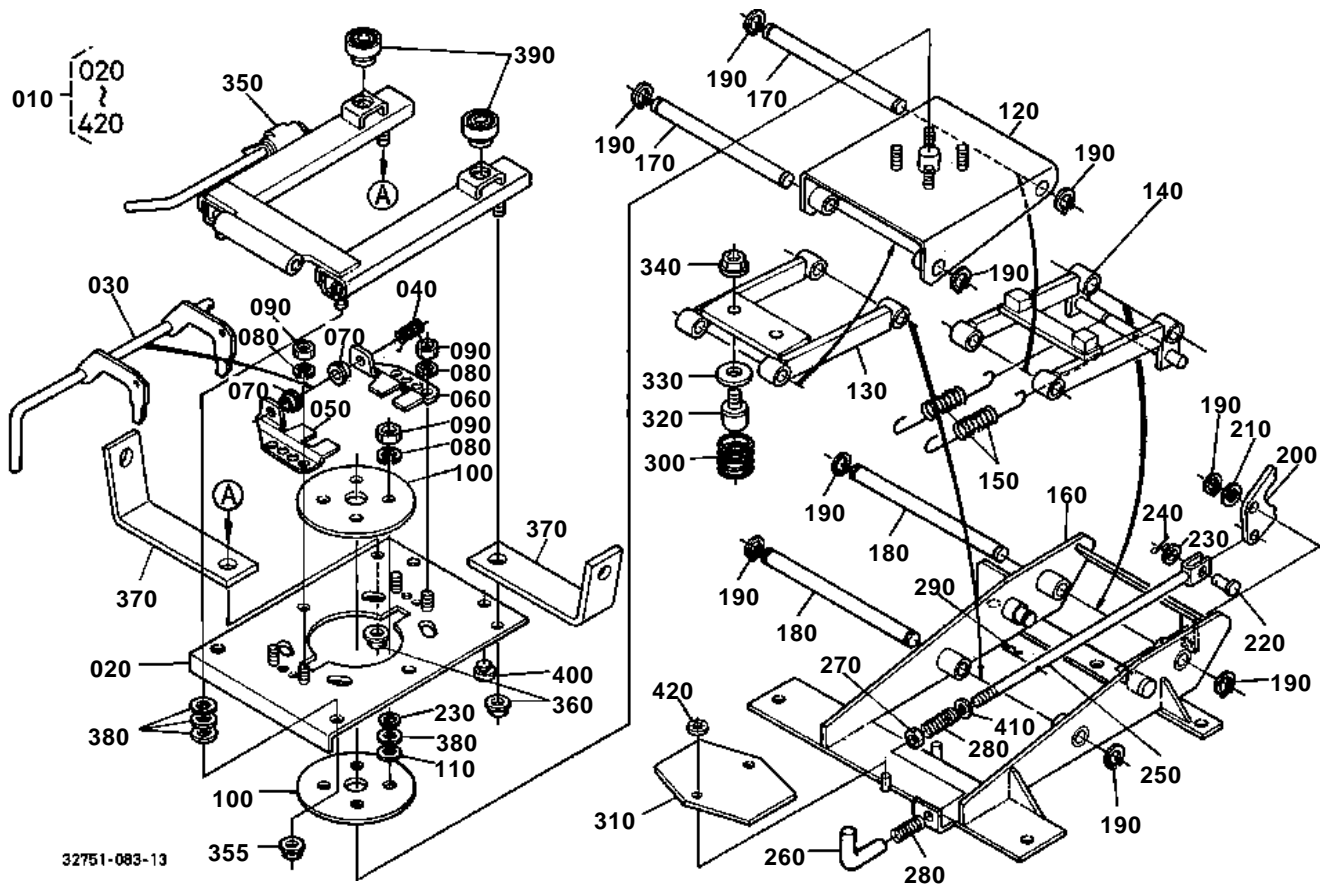

010 32751-4774-0

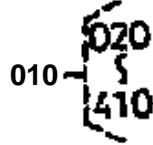

140 32751-4787-0

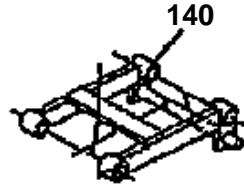

160 32751-4789-0

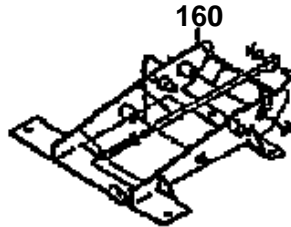

310 66301-5282-0

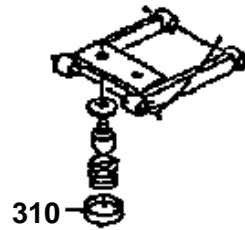

360 02783-50100

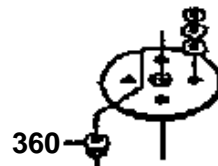

370 32751-1858-0



32751-811-12



REVERSIBLE SEAT BASE [COMPONENT PARTS]

↔ Interchangeable; ≠ not interchangeable; ← new for old; → old for new

REF.No	Part No.	Description	Q'ty	S.No.	I/C	REMARKS	Weight (kgf)	Weight (lb)
010	32751-47740	BASE REVERSIBL SEAT	1	<=50801			0	0
010	32751-47743	BASE REVERSIBL SEAT	1	>=50802	-		0	0
010	32751-47746	BASE REVERSIBL SEAT	1	>=64246	-		0	0
010	32751-47747	BASE REVERSIBL SEAT	1	>=73825	-		14.5	31.9
020	32751-47810	PLATE SEAT TURN	1				1.31	2.882
030	32751-47820	LEVER CLAMP	1				0.215	0.473
040	32751-47830	SPRING	1				0.019	0.0418
050	32751-47920	RETAINER	1				0.085	0.187
060	32751-47930	RETAINER	1				0.085	0.187
070	32751-47940	BUSH	2				0.002	0.0044
080	04512-60080	WASHER SPRING	8				0.002	0.0044
090	02114-50080	NUT	8				0.005	0.011
100	32751-47900	PLATE	2				0.517	1.1374
110	32751-47850	SHIM	4				0.003	0.0066
120	32751-47840	COMP.BASE TURN TABLE	1				1.475	3.245
130	32751-47860	LINK SUSPENSION	1				0.872	1.9184
140	32751-47870	LINK SUSPENSION	1	<=50801			0	0
140	32751-47872	LINK SUSPENSION	1	>=50802	-		0	0
140	32751-47874	LINK SUSPENSION	1	>=60505	-		0.95	2.09
150	32751-47910	SPRING	2	<=60504			0	0
150	32751-47912	SPRING	2	>=60505	-		0.15	0.33
160	32751-47890	COMP.BASE SEAT	1	<=50801			0	0
160	32751-47893	COMP.BASE SEAT	1	>=50802	-		4	8.8
160	32751-47894	COMP.BASE SEAT	1	>=60505	-		4	8.8
170	32701-52840	PIN FULCRUM	2				0.17	0.374
180	32751-47880	PIN	2				0.185	0.407
190	04613-00100	CIR CLIP EXTERNAL	9				0.001	0.0022
190	04613-50100	CIRCLIP EXTERNAL	9		-		0.002	0.0044
200	32751-47970	LEVER CLAMP	1				0.067	0.1474
210	04013-60120	WASHER PLAIN	2				0.01	0.022
220	05122-50816	PIN JOINT	1				0.007	0.0154
230	04012-50080	WASHER PLAIN	5				0.001	0.0022
240	05511-50215	PIN SPLIT	1				0.001	0.0022
250	32751-47980	ROD RELEASE	1	<=60504			0.09	0.198
250	32751-47983	ROD RELEASE	1	>=60505	-		0.072	0.1584
260	32751-47790	GRIP	1				0.053	0.1166
270	02014-50060	NUT	1				0.002	0.0044
280	31355-82280	SPRING	2				0.001	0.0022
290	05525-50600	PIN SNAP	1				0	0
300	66301-52810	SPRING SEAT	2				0.12	0.264
310	66301-52820	CAP SPRING	2	<=60504			0.04	0.088
310	32751-47950	CUSHION	1	>=60505	-		0.086	0.1892
320	69181-48310	CUSHION	2				0.04	0.088
330	04015-60080	WASHER PLAIN	2				0.01	0.022
340	02751-50080	NUT FLANGE	2				0.006	0.0132
350	TA040-18430	ASSY ADJUSTER SEAT	1				2.3	5.06
355	02783-50100	NUT FLANGE	2	>=72042			0.01	0.022
360	02783-50100	NUT FLANGE	4	<=72041			0.01	0.022
360	02783-50100	NUT FLANGE	2	>=72042			0.01	0.022
370	32751-18580	STAY SEAT BELT	2	<=73824			0.38	0.836
370	32751-18582	STAY SEAT BELT	2	>=73825	-		0.38	0.836



REVERSIBLE SEAT BASE [COMPONENT PARTS]

↔ Interchangeable; ≠ not interchangeable; ← new for old; → old for new

REF.No	Part No.	Description	Q'ty	S.No.	I/C	REMARKS	Weight (kgf)	Weight (lb)
380	04011-50100	WASHER PLAIN	10				0.002	0.0044
390	32160-18440	CUSHION	2				0.013	0.0286
400	38240-29870	CUSHION	2				0.004	0.0088
410	04013-60060	WASHER PLAIN	1				0.001	0.0022
420	52300-26220	NUT	2	>=60505			0.001	0.0022

STEP

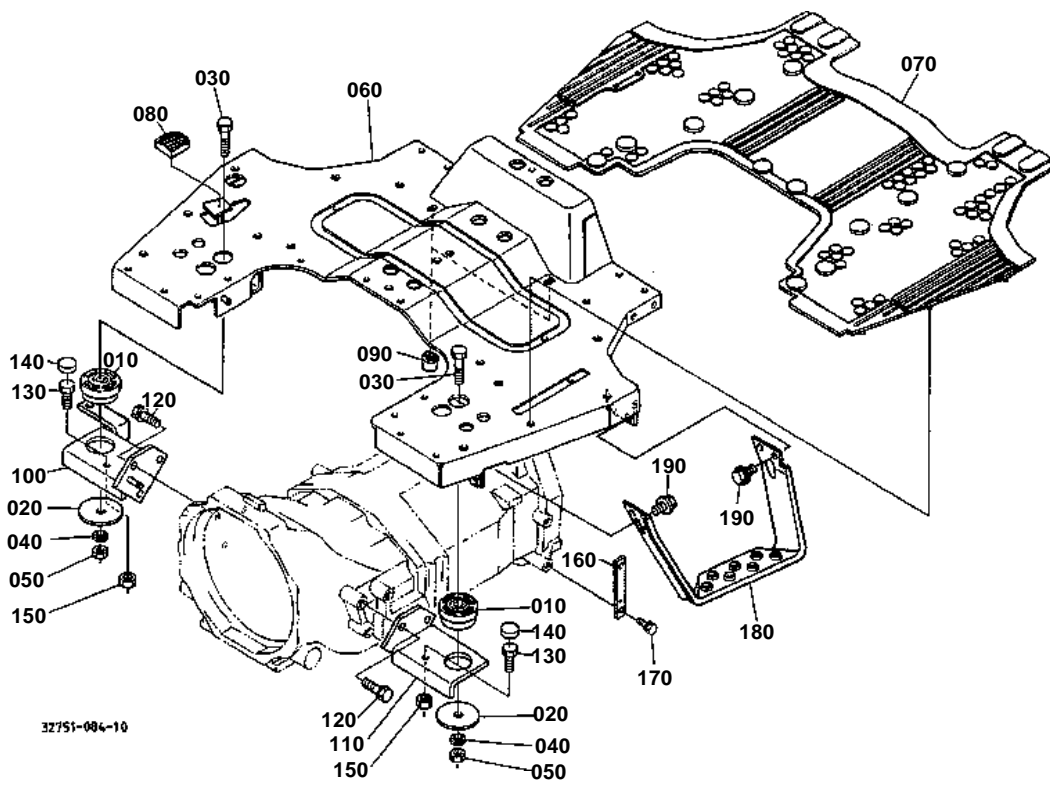

**STEP**

↔ Interchangeable; ≠ not interchangeable; ← new for old; → old for new

REF.No	Part No.	Description	Q'ty	S.No.	I/C	REMARKS	Weight (kgf)	Weight (lb)
010	34070-47310	CUSHION	2				0.165	0.363
020	34070-47320	WASHER	2				0.1	0.22
030	01173-51660	BOLT	2				0.114	0.2508
040	04512-50160	WASHER SPRING	2				0	0
050	02176-50160	NUT	2				0.021	0.0462
060	32751-47400	STEP	1				0	0
060	32751-47404	STEP	1		«		16.5	36.3
070	34070-47454	MAT	1				2.4	5.28
080	37410-42760	COVER PEDAL	1				0.025	0.055
090	30400-17980	RUBBER BLOCK	2				0.01	0.022
100	32751-47410	BRACKET STEP RH	1				1.9	4.18
110	34070-47420	BRACKET STEP LH	1				0.22	0.484
120	01133-51230	BOLT	6				0.04	0.088
130	01073-51030	BOLT	2				0.028	0.0616
140	34070-47490	CUSHION	2				0.005	0.011
150	02118-50100	NUT	2				0.005	0.011
160	T0070-15990	SUPPORT	1				0.12	0.264
170	01133-51020	BOLT	2				0.02	0.044
180	TA040-47470	STEP AID	1				0.86	1.892
190	01754-50812	BOLT FLANGE	4				0.01	0.022

MAIN FRAME

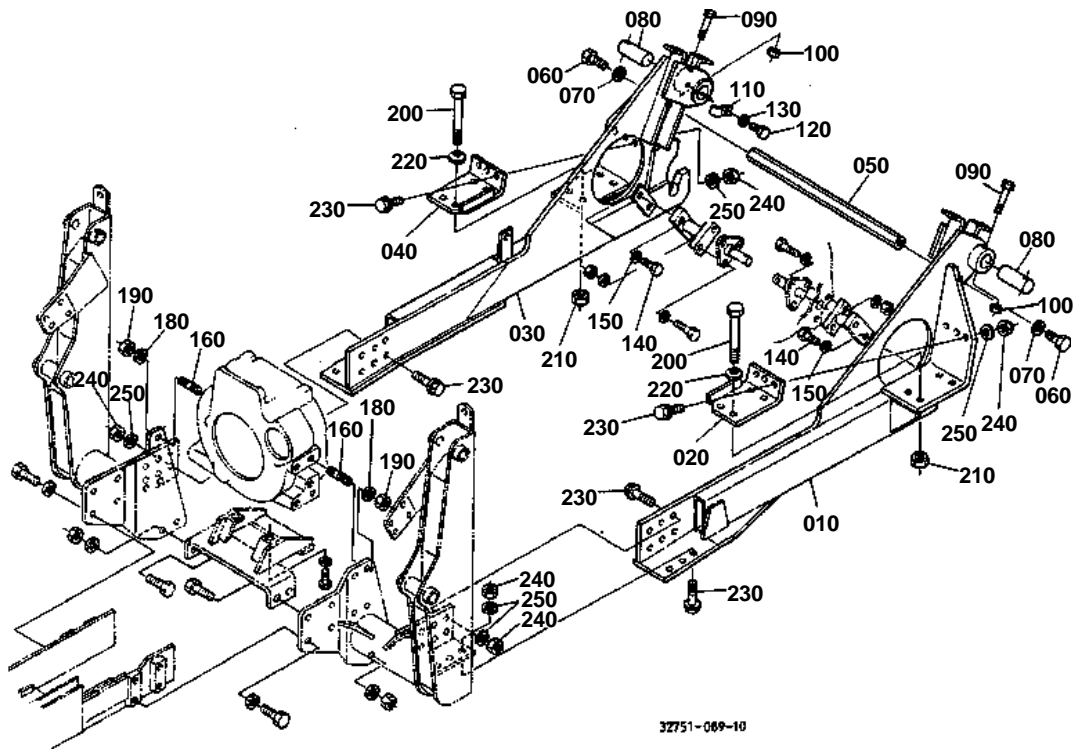

32751-069-10

**MAIN FRAME**

↔ Interchangeable; ≠ not interchangeable; ← new for old; → old for new

REF.No	Part No.	Description	Q'ty	S.No.	I/C	REMARKS	Weight (kgf)	Weight (lb)
010	32751-29110	FRAME MAIN LH	1				0	0
020	32751-29120	SUPPORT MAIN FRAME	1				0	0
030	32751-29150	FRAME MAIN RH	1				0	0
040	32751-29160	SUPPORT MAIN FRAME	1				0	0
050	32751-29130	ROD MAIN FRAME	1				0.005	0.011
060	75599-04730	BOLT	2				0	0
070	75599-33010	WASHER SPRING	2				0.001	0.0022
080	32751-29140	PIN MAIN FRAME	2				0.91	2.002
090	75599-01165	BOLT	2				0.022	0.0484
100	75599-31011	NUT	2				0.004	0.0088
110	32751-29210	SUPPORT HOSE	1				0	0
120	75599-04312	BOLT	1				0.016	0.0352
130	75599-33010	WASHER SPRING	1				0.001	0.0022
130	0Y450-50060	WASHER SPRING	1			-	0.003	0.0066
140	75599-04430	BOLT	4				0	0
150	75599-33010	WASHER SPRING	4				0.001	0.0022
160	32580-44960	STUD	2				0.05	0.11
170	99999-99999	BLANK	0				0	0
180	04512-50140	WASHER SPRING	2				0	0
190	02076-50140	NUT	2				0.022	0.0484
200	32430-34740	BOLT	8				0.3	0.66
210	02174-50160	NUT	8				0.022	0.0484
220	36500-49410	SPRING PLATE	8				0.022	0.0484
230	01779-51445	BOLT UBS	24				0.083	0.1826
240	02076-50140	NUT	24				0.022	0.0484
250	04512-50140	WASHER SPRING	24				0	0

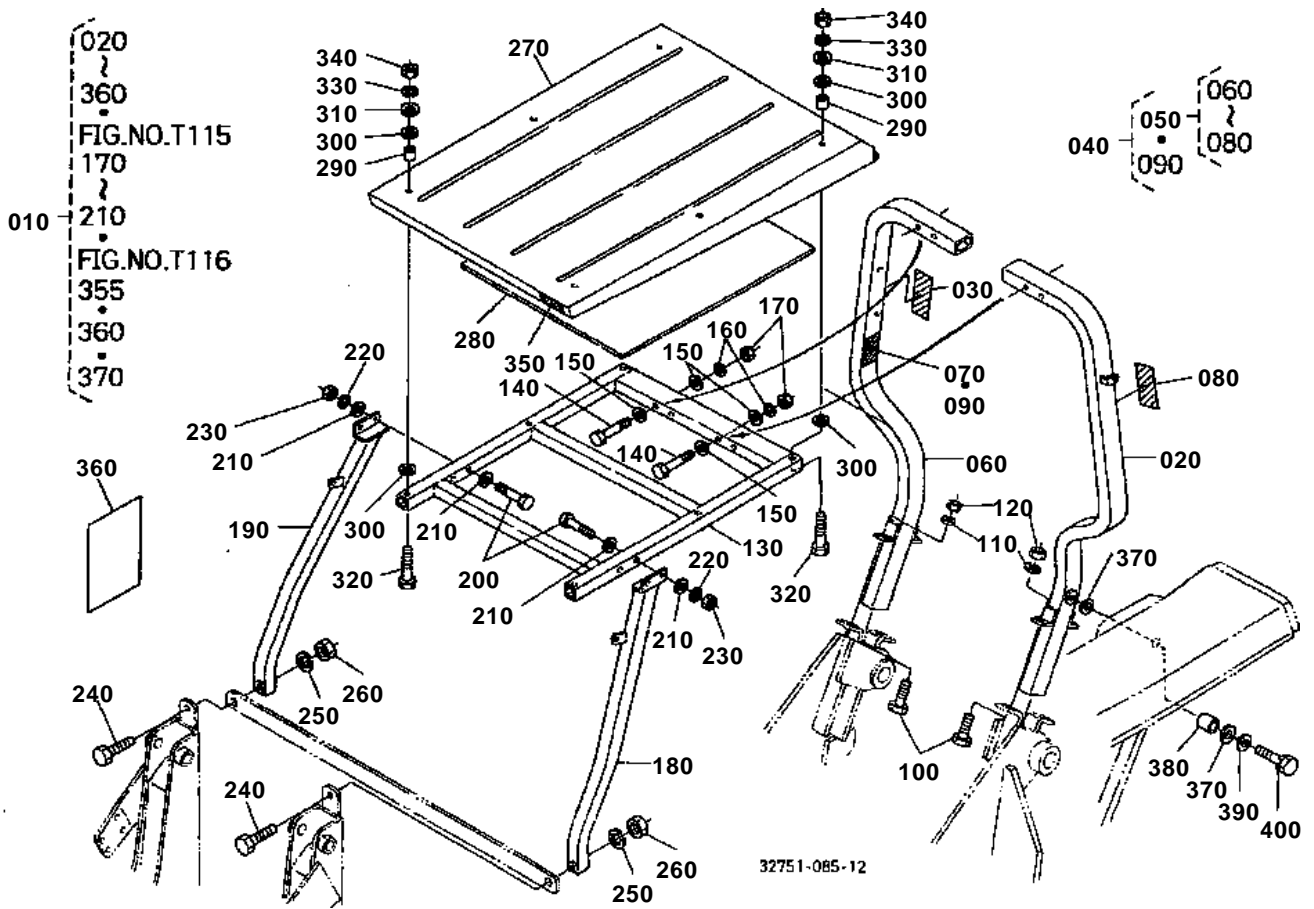



ROPS AND FOPS

↔ Interchangeable; ≠ not interchangeable; ← new for old; → old for new

REF.No	Part No.	Description	Q'ty	S.No.	I/C	REMARKS	Weight (kgf)	Weight (lb)
010	32751-93940	ROPS KIT	1				0	0
020	99999-99999	COMP.FRAME LH	1				0	0
030	6C140-54990	REFLECTOR LABEL	1				0.003	0.0066
040	32765-34602	KIT FRAME RH (B)	1				0	0
050	32751-34602	KIT FRAME RH (A)	1				0	0
060	99999-99999	COMP.FRAME RH	1				0	0
070	6C140-47460	LABEL ROPS WARNING	1				0.001	0.0022
080	6C140-54990	REFLECTOR LABEL	1				0.003	0.0066
090	6C141-47460	LABEL ROPS WARNING	1				0.001	0.0022
100	32530-29030	BOLT	4				0.12	0.264
110	04512-60160	WASHER SPRING	4				0.01	0.022
120	32530-29040	NUT	4				0.03	0.066
130	99999-99999	COMP.FRAME(UPPER)	1				0	0
140	75599-04590	HEX.BOLT	4				0.13	0.286
150	75599-32115	WASHER PLAIN	8				0.02	0.044
160	75599-33015	WASHER SPRING LOCK	4				0.006	0.0132
160	0Y450-50080	WASHER SPRING	4		→		0	0
170	75599-31025	HEX.NUT	4				0.015	0.033
180	99999-99999	COMP FRAME(F/LH)	1				0	0
190	99999-99999	COMP FRAME(F/RH)	1				0	0
200	75599-04560	HEX.BOLT	4				0.09	0.198
210	75599-32115	WASHER PLAIN	8				0.02	0.044
220	75599-33015	WASHER SPRING LOCK	4				0.006	0.0132
220	0Y450-50080	WASHER SPRING	4		→		0	0
230	75599-31025	HEX.NUT	4				0.015	0.033
240	75599-04680	HEX.BOLT	2				0.143	0.3146
250	75599-33016	WASHER SPRING	2				0.08	0.176
250	0Y450-50090	WASHER SPRING	2		→		0.007	0.0154
260	75599-31946	NUT LOCKING	2				0.03	0.066
270	99999-99999	CANOPY FOPS	1				0	0
280	32751-34990	ACOUSTIC FORM	1				0	0
290	32751-34860	SPACER	6				0.016	0.0352
300	32751-34870	CUSHION	12				0.01	0.022
310	75599-32113	WASHER PLAIN	6				0.01	0.022
320	75599-04330	BOLT	6				0.035	0.077
330	75599-33013	WASHER SPRING	6				0.006	0.0132
330	0Y450-50060	WASHER SPRING	6		→		0.003	0.0066
340	75599-31023	NUT	6				0.006	0.0132
350	32751-34880	LABEL KUBOTA MARK	1				0.001	0.0022
360	32751-93960	MANUAL ROPS KIT	1				0	0
370	38240-18640	CUSHION	4				0.01	0.022
380	32530-29940	SPACER	2				0.01	0.022
390	04015-50100	WASHER PLAIN	2				0	0
400	01133-51035	BOLT	2				0.03	0.066

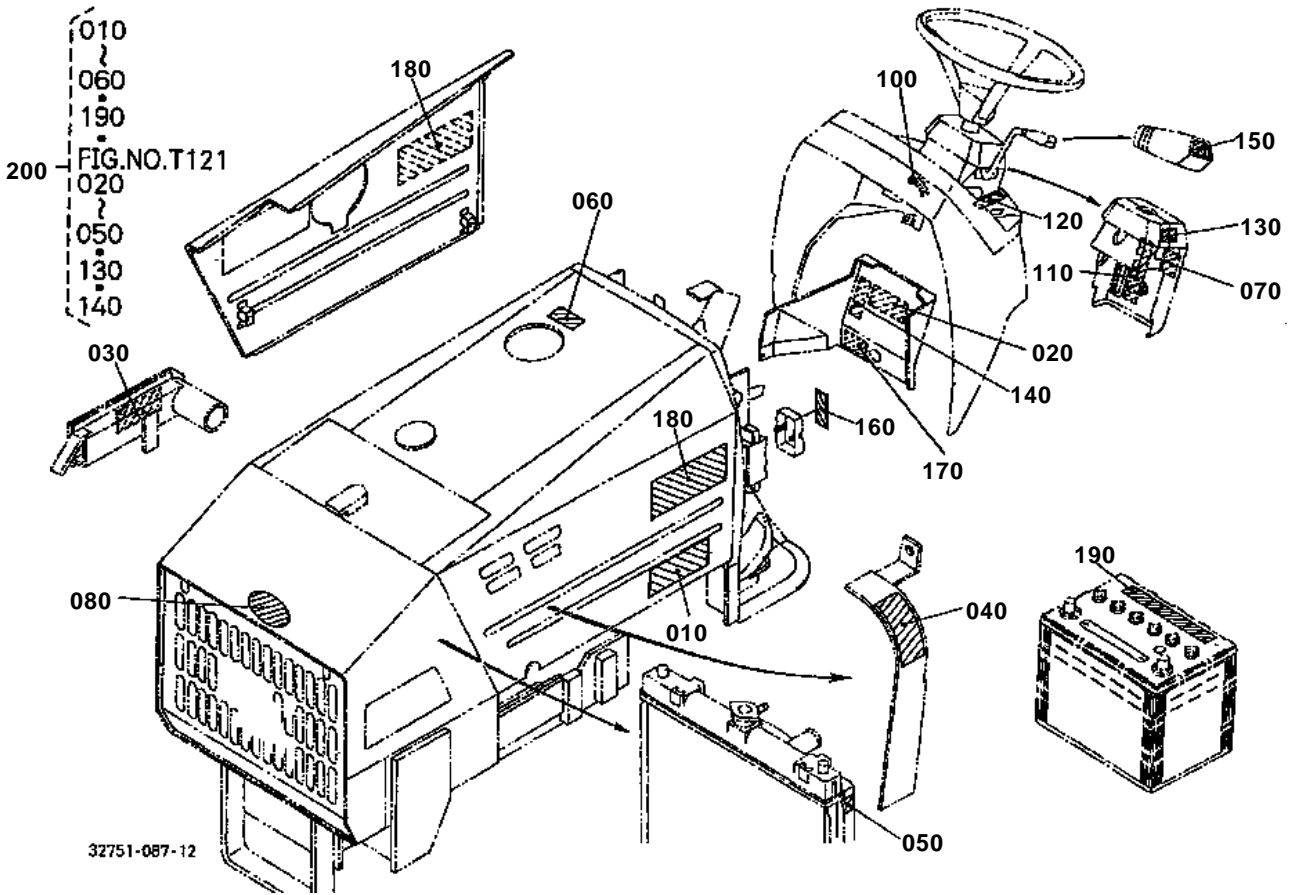

080 T0070-4948-0

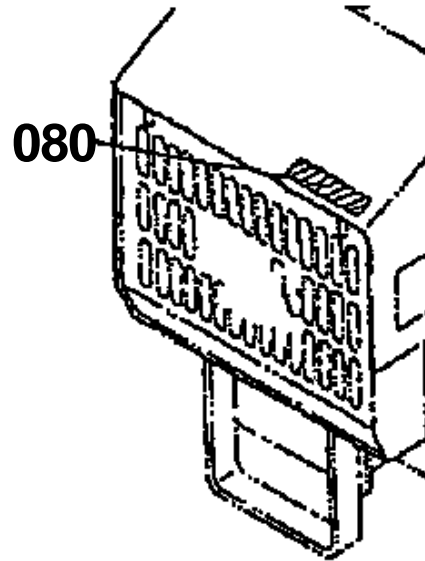

090 32430-6545-3

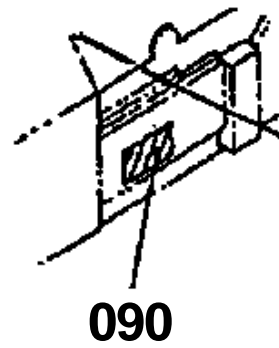

160 32751-3042-0

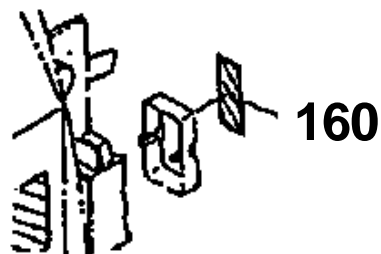

32751-816-11



LABEL 1

↔ Interchangeable; ≠ not interchangeable; ← new for old; → old for new

REF.No	Part No.	Description	Q'ty	S.No.	I/C	REMARKS	Weight (kgf)	Weight (lb)
010	TA040-49650	LABEL START CAUTION	1			ENGLISH	0.004	0.0088
010	TA041-49650	LABEL START CAUTION	1			FRENCH	0.004	0.0088
020	35080-65280	LABEL KEY STOP	1			ENGLISH	0.001	0.0022
020	35081-65280	LABEL KEY STOP	1			FRENCH	0.02	0.044
030	32751-49570	LABEL FAN WARNING	1				0.002	0.0044
040	32751-49580	LABEL FAN BELT	1				0.001	0.0022
050	TA040-49580	LABEL MUFFLER	1	<=72272			0.001	0.0022
050	TC030-49580	LABEL MUFFLER	1	>=72273	—		0.001	0.0022
060	TA040-49560	LABEL FUEL	1				0	0
060	TA040-49562	LABEL FUEL	1		«		0.002	0.0044
070	TA040-49390	LABEL SHUTTLE	1			ENGLISH	0.001	0.0022
070	TA041-49390	LABEL SHUTTLE	1			FRENCH	0.002	0.0044
080	T0070-49480	MARK KUBOTA	1	<=71069			0.007	0.0154
080	T1060-49500	MARK SYMBOL	1	>=71070	1		0.01	0.022
090	32430-65453	NAME PLATE	1	<=71191			0.005	0.011
100	TA040-49360	MARK MAIN SWITCH	1	<=72556			0.001	0.0022
100	TA140-49360	MARK MAIN SWITCH	1	>=72557	1		0.002	0.0044
110	TA040-49450	MARK TILT	1				0.001	0.0022
120	TA040-49290	MARK SHUTTLE	1				0.001	0.0022
120	T1060-49290	MARK SHUTTLE	1		«		0.001	0.0022
130	TA040-49540	MARK NEUTRAL	1				0.001	0.0022
140	TA040-49460	LABEL PARKING	1				0.001	0.0022
150	TA040-49380	MARK SHUTTLE GRIP	1				0.001	0.0022
160	32751-30420	LABEL FUSE	1	<=72556		ENGLISH	0.001	0.0022
160	32765-30420	LABEL FUSE	1	<=72556		FRENCH	0.002	0.0044
160	32765-30422	LABEL FUSE	1	>=72557	1	FRENCH	0.002	0.0044
170	32751-49160	LABEL PTO	1				0.001	0.0022
180	32751-49430	MARK MODEL	2				0.007	0.0154
190	TA040-30150	LABEL BATTERY	1			ENGLISH	0.002	0.0044
190	TA041-30150	LABEL BATTERY	1			FRENCH	0.005	0.011
200	32751-99500	KIT LABEL SAFETY (A)	1	<=72946		ENGLISH	0	0
200	32751-99503	KIT LABEL SAFETY (A)	1	>=72947	—	ENGLISH	0.02	0.044

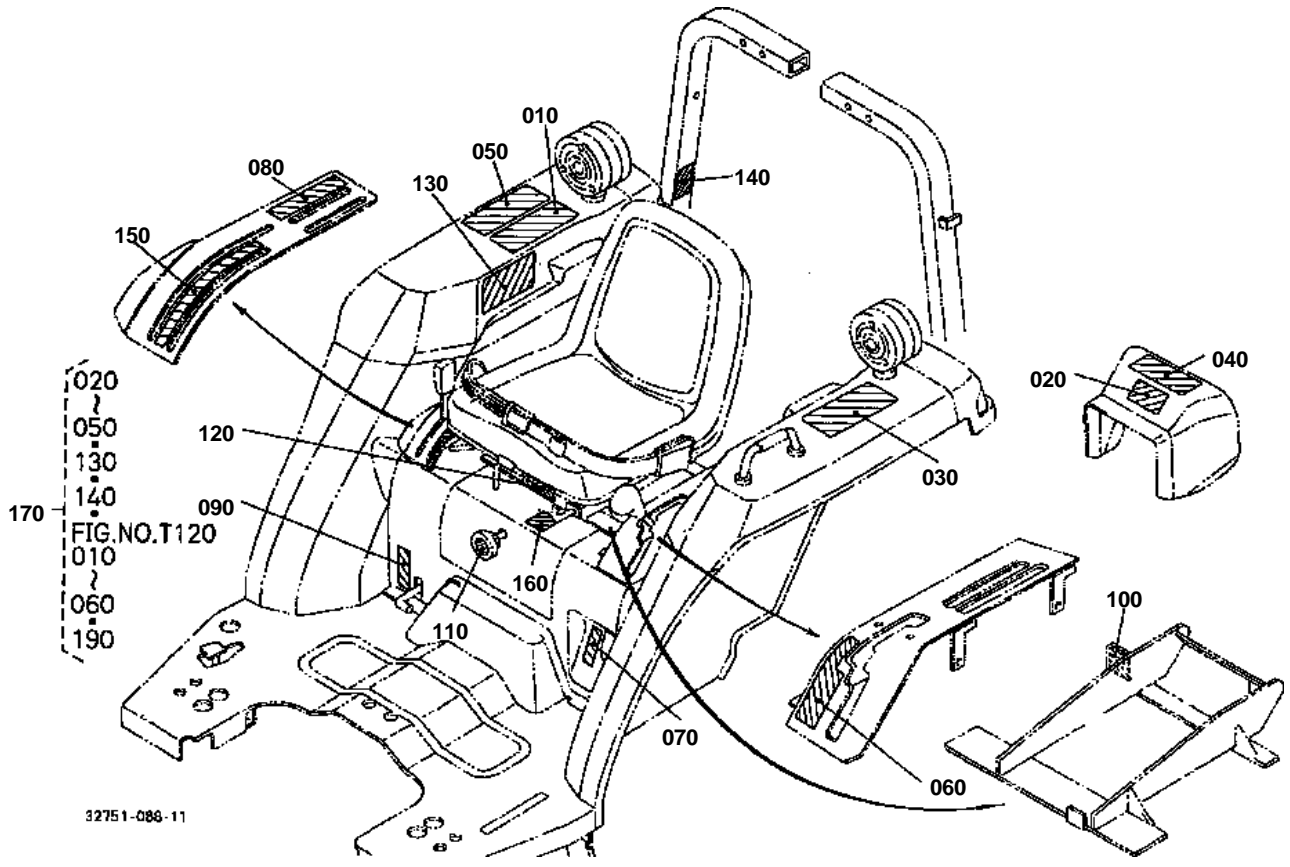



LABEL 2

↔ Interchangeable; ≠ not interchangeable; ← new for old; → old for new

REF.No	Part No.	Description	Q'ty	S.No.	I/C	REMARKS	Weight (kgf)	Weight (lb)
010	TA040-49320	LABEL ROPS WARNING	1	<=71953		ENGLISH	0.001	0.0022
010	32771-49250	LABEL ROPS WARNING	1	>=71954	-	ENGLISH	0.001	0.0022
010	TA040-49150	LABEL ROPS WARNING	1	<=72556		FRENCH	0.003	0.0066
010	32775-49250	LABEL ROPS WARNING	1	>=72557	1	ENGLISH	0.004	0.0088
020	TA040-49350	LABEL DRAWBAR	1			ENGLISH	0.002	0.0044
020	TA041-49350	LABEL DRAWBAR	1			FRENCH	0.003	0.0066
030	35260-34913	LABEL SAFETY	1	<=72946		ENGLISH	0	0
030	35260-34914	LABEL SAFETY	1	>=72947	-	ENGLISH	0.005	0.011
030	TA041-65700	LABEL SAFETY	1	<=72946		FRENCH	0	0
030	TA041-65702	LABEL SAFETY	1	>=72947	-	FRENCH	0.01	0.022
040	TA040-49590	LABEL PTO WARNING	1			ENGLISH	0	0
040	TA041-49590	LABEL PTO WARNING	1			FRENCH	0.001	0.0022
050	TA040-49330	LABEL SHUTTLE	1			ENGLISH	0.005	0.011
050	TA041-49330	LABEL SHUTTLE	1			FRENCH	0.004	0.0088
060	TA040-49210	MARK SHIFT	1	<=60504			0.005	0.011
060	32751-49220	MARK SHIFT	1	>=60505	-		0	0
070	TA040-49550	MARK 4WD	1				0.001	0.0022
080	32751-49450	LABEL SPEED SET	1				0.003	0.0066
090	TA040-49760	MARK DIFF.LOCK	1				0.001	0.0022
100	32751-49380	LABEL HYDRAULIC	1			ENGLISH	0.001	0.0022
100	32765-49380	LABEL HYDRAULIC	1			FRENCH	0.001	0.0022
110	TA040-49510	MARK HYD.ADJUST.	1	<=72428			0.001	0.0022
110	TA470-49330	MARK HYD.ADJUST.	1	>=72429	1		0.001	0.0022
120	32751-49250	LABEL SEAT LOCK	1			ENGLISH	0.001	0.0022
120	32765-49250	LABEL SEAT LOCK	1			FRENCH	0.001	0.0022
130	32751-49210	LABEL SEAT WARNING	1			ENGLISH	0.002	0.0044
130	32765-49210	LABEL SEAT WARNING	1			FRENCH	0.002	0.0044
140	6C140-47460	LABEL ROPS WARNING	1			ENGLISH	0.001	0.0022
140	6C141-47460	LABEL ROPS WARNING	1			FRENCH	0.001	0.0022
150	TA040-49500	MARK POSITION	1				0.002	0.0044
160	32751-49260	LABEL SEAT CHANGE	1			ENGLISH	0.002	0.0044
160	32765-49260	LABEL SEAT CHANGE	1			FRENCH	0.002	0.0044
170	32751-99500	KIT LABEL SAFETY (A)	1	<=72946		ENGLISH	0	0
170	32751-99503	KIT LABEL SAFETY (A)	1	>=72947	-	ENGLISH	0.02	0.044

**ACCESSORIES AND SERVICE PARTS
ACCESSOIRES ET PIECES DE SERVICE
SONTIGES ZUBEHOER UND SERVICE-TEILE**

TITLE-001-10



ACCESSORIES AND SERVICE PARTS

↔ Interchangeable; ≠ not interchangeable; ← new for old; → old for new

REF.No	Part No.	Description	Q'ty	S.No.	I/C	REMARKS	Weight (kgf)	Weight (lb)
010	32751-19710	MANUAL INSTRUCTION	1	<=60894		ENGLISH	0	0
010	32751-19712	OPERATOR'S MANUAL	1	>=60895	↔	ENGLISH	0	0
010	32751-19713	OPERATOR'S MANUAL	1	>=64246	1	ENGLISH	0	0
010	32751-19714	OPERATOR'S MANUAL	1	>=64751	1	ENGLISH/NOT SALE	0	0
010	32751-19716	OPERATOR'S MANUAL	1	>=72042	↔	ENGLISH	0	0
010	32751-19717	OPERATOR'S MANUAL	1	>=72557	1	ENGLISH	0.15	0.33
010	32765-19710	MANUAL INSTRUCTION	1	<=64245		FRENCH/NOT SALE	0	0
010	32765-19712	OPERATOR'S MANUAL	1	>=64246	1	FRENCH/NOT SALE	0	0
010	32765-19713	OPERATOR'S MANUAL	1	>=70975	↔	FRENCH/NOT SALE	0	0
010	32765-19714	OPERATOR'S MANUAL	1	>=72042	↔	FRENCH/NOT SALE	0	0
010	32765-19715	OPERATOR'S MANUAL	1	>=72557	1	FRENCH/NOT SALE	0	0
020	32751-19770	MANUAL ASSEMBLY	1			NOT SALE	0	0
025	1G511-89810	STATEMENT WARRANTY	1				0	0
030	35260-31852	ASSY KEY MAIN SWITCH	1				0.03	0.066
040	01073-51630	BOLT	8			FOR REAR WHEEL	0.079	0.1738
050	02076-50160	NUT	4			FOR REAR WHEEL	0.03	0.066
060	01517-51632	STUD	4			FOR REAR WHEEL	0.076	0.1672
070	04512-50160	WASHER SPRING	12			FOR REAR WHEEL	0	0
080	01517-51428	STUD	12			FOR FRONT WHEEL	0.05	0.11
090	35340-11390	NUT	12			FOR FRONT WHEEL	0.03	0.066
100	32430-18450	BRACKET SEAT RH	1				0.08	0.176
110	32430-18460	BRACKET SEAT LH	1				0.08	0.176
120	01754-50816	BOLT FLANGE	4				0.011	0.0242
130	32430-34740	BOLT	8				0.3	0.66
140	02174-50160	NUT	8				0.022	0.0484
150	36500-49410	SPRING PLATE	8				0.022	0.0484
160	01779-51445	BOLT UBS	24				0.083	0.1826
170	02076-50140	NUT	24				0.022	0.0484
180	04512-50140	WASHER SPRING	24				0	0
190	32751-39420	BRACKET	2				0.56	1.232
200	01175-51060	BOLT	4				0.04	0.088
210	04512-50100	WASHER SPRING	8				0	0
220	02176-50100	NUT	4				0.005	0.011
230	32530-29030	BOLT	4				0.12	0.264
240	32530-29040	NUT	4				0.03	0.066
250	04512-50160	WASHER SPRING	4				0	0
260	67401-45922	STAY	1				0.08	0.176
270	01123-50816	BOLT	2				0	0
280	66704-54952	BRACKET SMV	1				0.15	0.33
290	01023-50618	BOLT	2				0.006	0.0132
300	04013-50060	WASHER PLAIN	2				0	0
310	04512-50060	WASHER SPRING	2				0	0
320	02014-50060	NUT	2				0.002	0.0044
330	32580-44960	STUD	2				0.05	0.11
340	04512-50140	WASHER SPRING	2				0	0
350	02076-50140	NUT	2				0.022	0.0484