

# Instructions for Parts Books

The heading at the top of the page will be the same for the picture of the parts at it is for the page with the part numbers.

Definition of column headings on part number pages:

**REF.No** → The number referring to the part on the picture page of the parts book.

**Part No.** → The number assigned to this part at the time of printing the parts book.

**Description** → Discription of part.

**Q'ty** → Quantity of part used on that page.

**S.No.** → Serial number range of the equipment that this part will fit.

>= Your serial number should be greater than or equal to the number shown.

<= Your serial number should be lesser than or equal to the serial number shown.

**I/C** → Interchangeability of part shown.

↔ The part shown will work for the older and later serial number.

# The part shown is not interchangeable with the other serial number.

← new for old

→ old for new

**Remarks** → Notes about this particulart part. Sometimes this may say except [FR] or [CA]

## Note about Country Codes:

The parts books we use in the United States of America may also contain information about a part that would be different in another country. It is important that you are aware of the country codes in some instances.

Symbol	Country
A	United States of America
CA	Canada
FR	France
GR	Greece
PO	Portugal
AU	Australia

If the remarks column says for example EXCEPT [FR] this part works in all countries except France. That means it will work here in the USA.

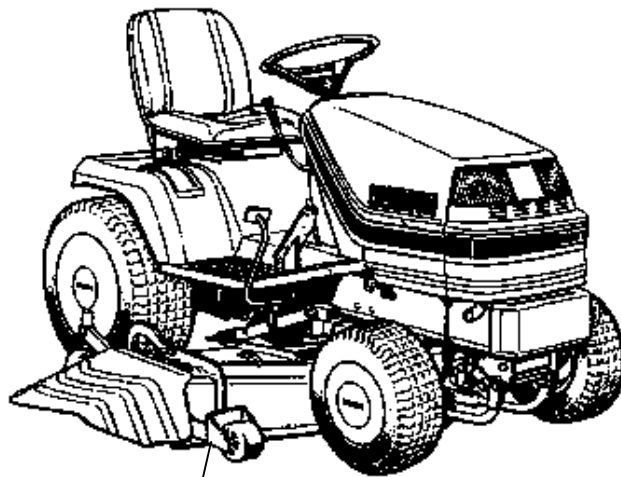

MOWER

Item	Part No.	Description	Book
MOWER	01G120	UNIVERSAL JOINT	100K0509
	01G122	GEAR BOX/CENTER PULLEY	100K0509
	01G124	PULLEY HOLDER/BLADE	100K0509
	01G126	SIDE PULLEY/BLADE	100K0509
	01G127	TENSION PULLEY	100K0509
	01G129	MOWER DECK	100K0509
	01G131	FRONT WHEEL	100K0509
	01G133	REAR WHEEL	100K0509
	01G136	DISCHARGE COVER	100K0509
	01G141	REAR LINKAGE	100K0509
	01G143	FRONT LINKAGE	100K0509
	01G144	MOWER ASSIST SPRING	100K0509
	01G146	ACCESSORIES AND SERVICE PARTS	100K0509

# UNIVERSAL JOINT

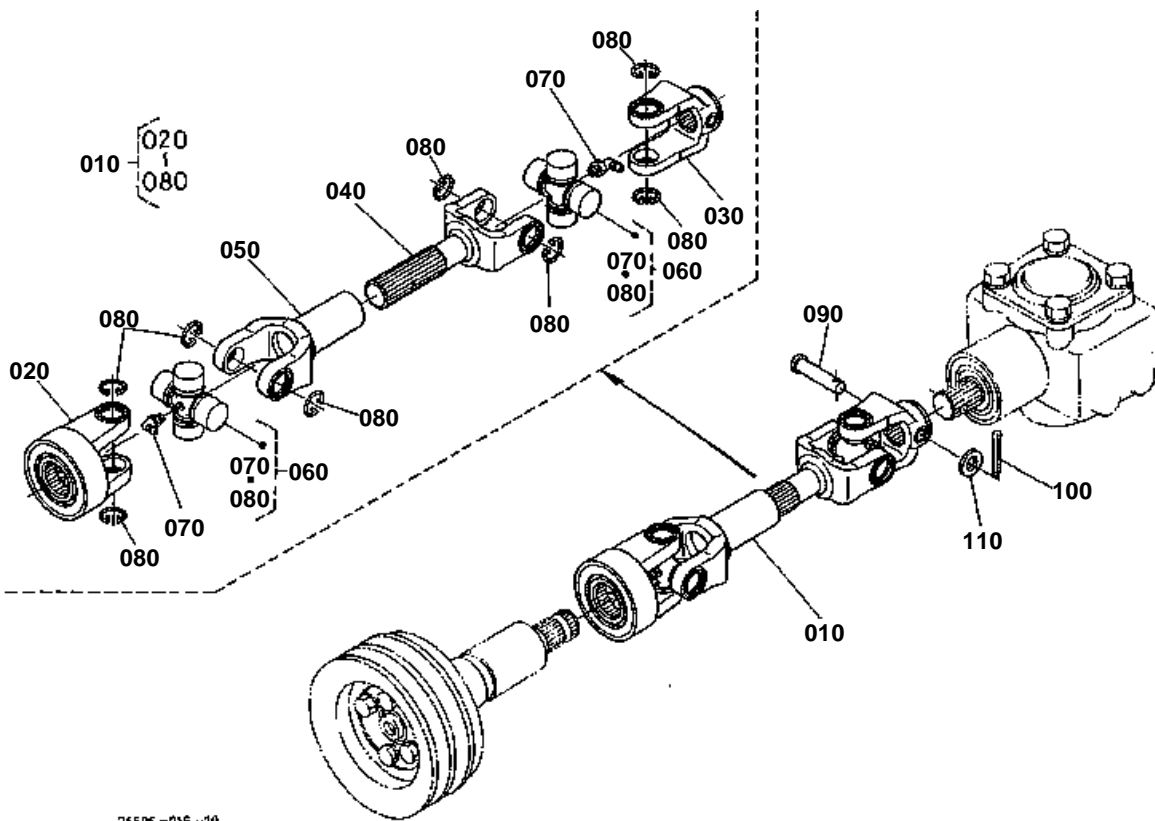

76505-015-10



# UNIVERSAL JOINT

↔ Interchangeable; ≠ not interchangeable; ← new for old; → old for new

REF.No	Part No.	Description	Q'ty	S.No.	I/C	REMARKS	Weight (kgf)	Weight (lb)
010	76505-32030	ASSY JOINT UNIVERSAL	1				2.5	5.5
020	76508-31150	YOKE QUICK	1				0.6	1.32
030	76508-31130	YOKE PTO	1				0.33	0.726
040	76505-31140	SHAFT JOINT	1				0.63	1.386
050	76505-31170	YOKE JOINT	1				0.51	1.122
060	76508-31180	ASSY JOINT CROSS	2				0.23	0.506
070	76508-31210	NIPPLE GREASE	2				0.05	0.11
080	76508-32120	RING SNAP	8				0.01	0.022
090	05122-50845	PIN JOINT	1				0.018	0.0396
100	05511-50218	PIN SPLIT	1				0.001	0.0022
110	04012-50080	WASHER PLAIN	1				0.001	0.0022

GEAR BOX/CENTER PULLEY

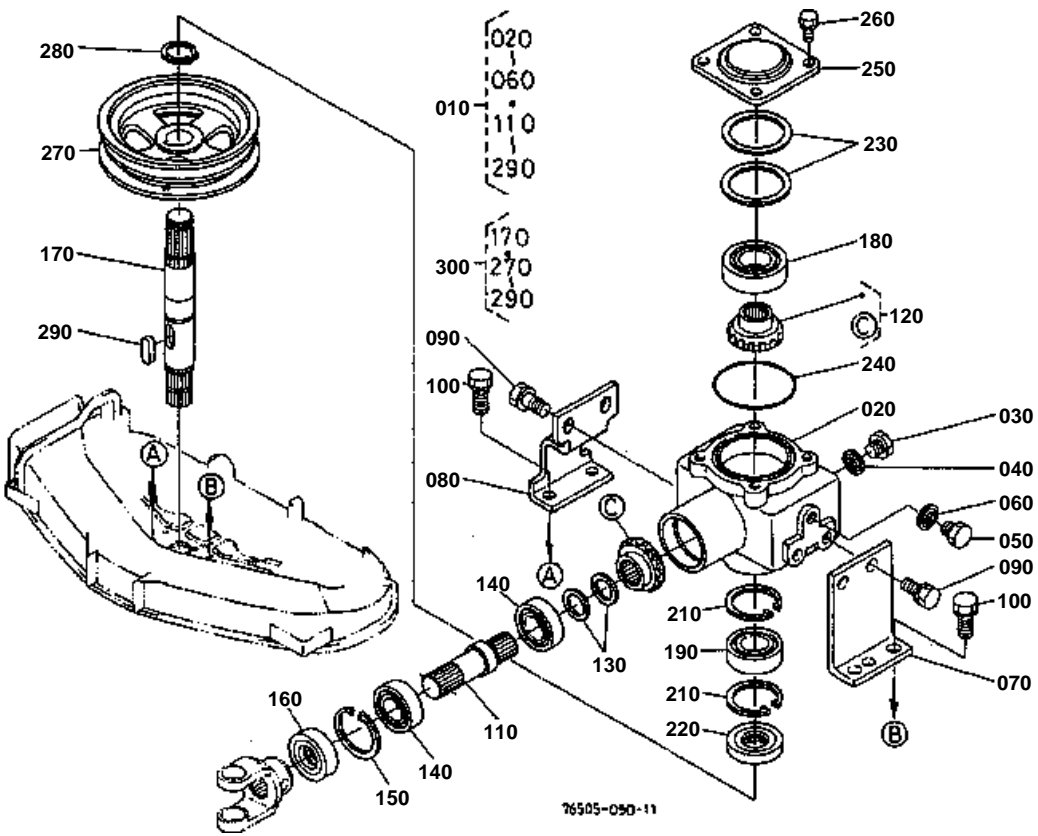

76505-050-11

080 76508-3315-0

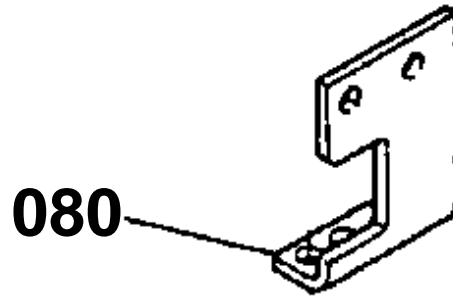

200 04612-00220

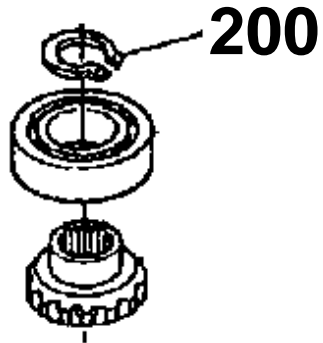

76505-800-11



## GEAR BOX/CENTER PULLEY

↔ Interchangeable; ≠ not interchangeable; ← new for old; → old for new

REF.No	Part No.	Description	Q'ty	S.No.	I/C	REMARKS	Weight (kgf)	Weight (lb)
010	76507-99060	ASSY CASE BEVEL GEAR	1	<=11691			7.76	17.072
010	76507-99062	ASSY CASE BEVEL GEAR	1	>=20001	≠		8.5	18.7
010	76507-99063	ASSY CASE BEVEL GEAR	1	>=30001	≠		8.5	18.7
010	76507-99064	ASSY CASE BEVEL GEAR	1	>=35771	←		7.8	17.16
020	76539-33112	CASE BEVEL GEAR	1				3.25	7.15
030	01173-51214	BOLT	1				0.025	0.055
040	04717-01200	WASHER WITH RUBBER	1				0.002	0.0044
050	01173-51214	BOLT	1				0.025	0.055
060	04717-01200	WASHER WITH RUBBER	1				0.002	0.0044
070	76508-33130	STAY BEVEL CASE LH	1				0.5	1.1
080	76508-33150	STAY BEVEL CASE RH	1	<=22057			0	0
080	76508-33152	STAY BEVEL CASE RH	1	>=30001	≠		0.7	1.54
090	01133-61222	BOLT	4				0.035	0.077
100	01133-51230	BOLT	4				0.04	0.088
110	70722-33310	SHAFT PINION	1				0.46	1.012
120	76507-33320	KIT GEAR BEVEL	1	<=22057		20-17T	0.2	0.44
120	76529-99020	KIT GEAR BEVEL	1	>=30001	≠	20-16T	0.48	1.056
130	70720-33350	SHIM	1			0.2MM	0.001	0.0022
130	70720-33360	SHIM	1			0.3MM	0.001	0.0022
140	08101-06205	BEARING BALL	2				0.14	0.308
150	04611-00520	CIR CLIP INTERNAL	1				0.009	0.0198
160	76535-33440	SEAL OIL	1				0.02	0.044
170	76508-33510	SHAFT BEVEL GEAR	1	<=11691			0.8	1.76
170	76508-33500	SHAFT BEVEL GEAR	1	>=20001	≠		0.78	1.716
170	76508-33502	SHAFT BEVEL GEAR	1	>=30001	≠		0	0
170	76508-33503	SHAFT BEVEL GEAR	1	>=35771	←		0.81	1.782
180	70712-33550	BEARING BALL	1				0.22	0.484
190	08101-06205	BEARING BALL	1				0.14	0.308
200	04612-00220	CIRCLIP EXTERNAL	1	<=35770			0.001	0.0022
210	04611-00520	CIR CLIP INTERNAL	2				0.009	0.0198
220	76535-33440	SEAL OIL	1				0.02	0.044
230	76539-33410	SHIM	1			0.2MM	0.001	0.0022
230	76539-33590	SHIM	1			0.3MM	0.005	0.011
240	04811-10800	RING	1				0.001	0.0022
250	70712-33610	COVER BEVEL CASE	1				0.2	0.44
260	01123-60814	BOLT	4				0.008	0.0176
270	76539-33520	PULLEY CENTER	1				1.65	3.63
280	04612-00250	CIRCLIP EXTERNAL	1				0.002	0.0044
290	05712-00728	KEY FEATHER	1				0.01	0.022
300	76508-99050	ASSY PULLEY CENTER	1	<=11691			2.48	5.456
300	76508-99052	ASSY PULLEY CENTER	1	>=20001	≠		2.5	5.5
300	76508-99053	ASSY PULLEY CENTER	1	>=30001	≠		2.56	5.632
300	76508-99054	ASSY PULLEY CENTER	1	>=35771	←		0	0



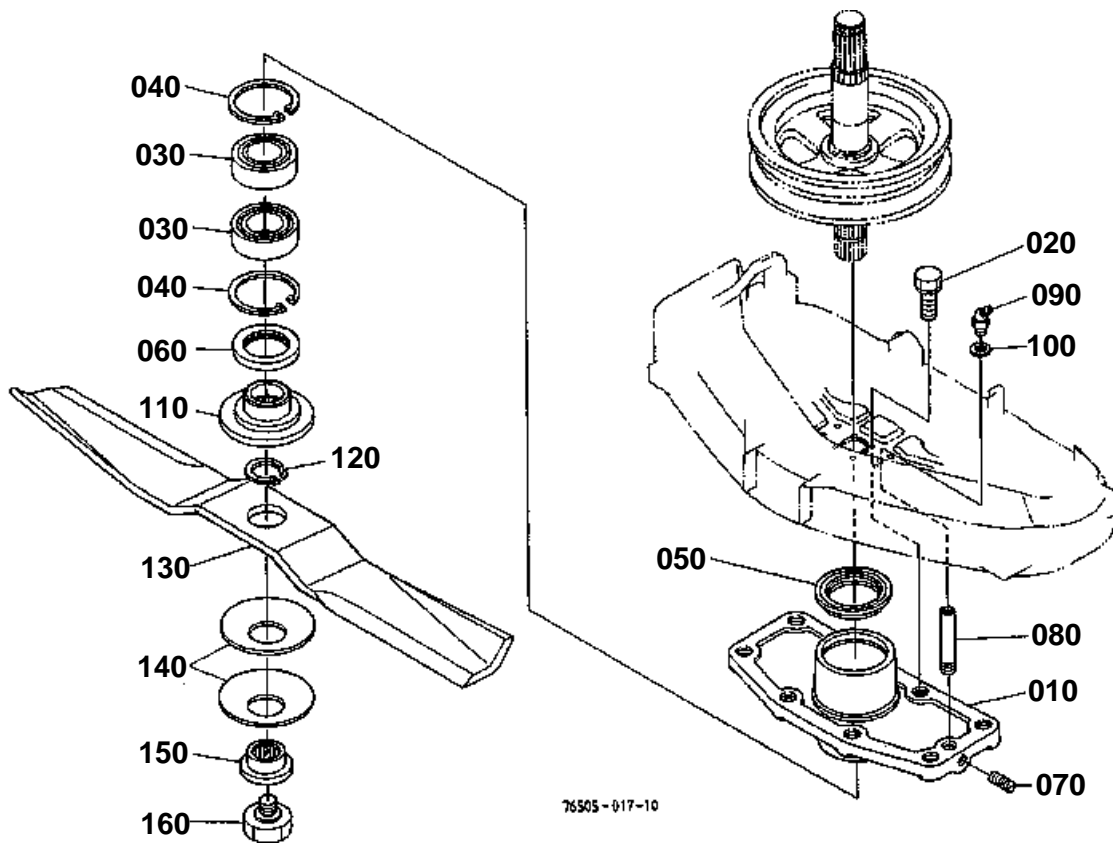

010 76539-3411-0  
030 08101-06205

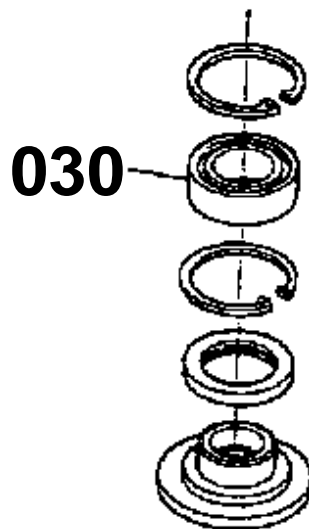
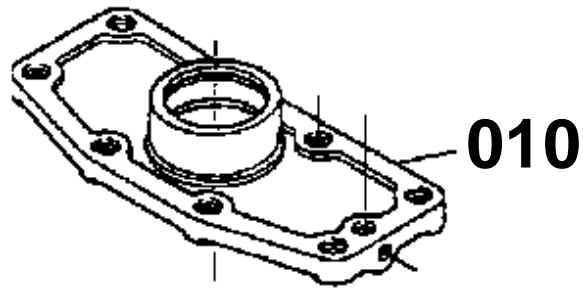

76505-811-10



PULLEY HOLDER/BLADE

↔ Interchangeable; ≠ not interchangeable; ← new for old; → old for new

REF.No	Part No.	Description	Q'ty	S.No.	I/C	REMARKS	Weight (kgf)	Weight (lb)
010	76539-34110	HOLDER PULLEY	1	≤22057			2.57	5.654
010	76539-34114	HOLDER CENTER PULLEY	1	≥30001	≠		0	0
010	76539-34116	HOLDER CENTER PULLEY	1	≥35747	←		2.75	6.05
020	01133-61222	BOLT	4				0.035	0.077
030	08101-06205	BEARING BALL	1	≤22057			0.14	0.308
030	08101-06205	BEARING BALL	2	≥30001			0.14	0.308
040	04611-00520	CIR CLIP INTERNAL	2				0.009	0.0198
050	70722-34120	SEAL OIL	1				0.025	0.055
060	09500-35528	SEAL OIL	1	≤34409			0.017	0.0374
060	70725-34162	SEAL OIL	1	≥34410	←		0.024	0.0528
070	03410-50606	SCREW SET	1				0.001	0.0022
080	76539-34132	PIPE EXTENSION	1				0.01	0.022
090	67111-44250	NIPPLE GREASE	1				0.005	0.011
100	66616-34390	SHIM ADJUSTING	1				0.001	0.0022
110	76539-34150	BOSS BLADE	1	≤11691			0.28	0.616
110	76539-34160	BOSS BLADE	1	≥20001	≠		0.42	0.924
110	76539-34150	BOSS BLADE	1	≥30001	≠		0.28	0.616
120	04612-00220	CIRCLIP EXTERNAL	1				0.001	0.0022
130	76529-34330	BLADE	1				1.45	3.19
140	76550-34350	RETAINER BLADE	2				0.075	0.165
150	76539-34390	JOINT BLADE BOSS	1				0	0
160	76539-34372	BOLT LOCKING BLADE	1				0.05	0.11

SIDE PULLEY/BLADE

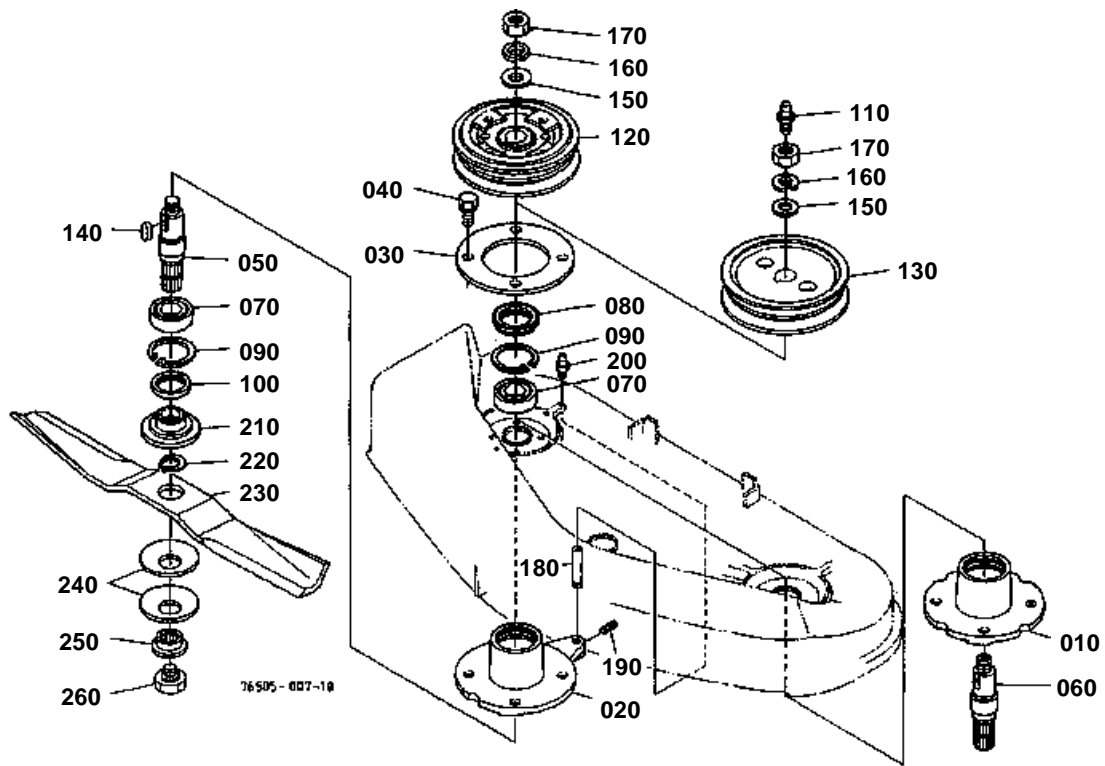



## SIDE PULLEY/BLADE

↔ Interchangeable; ≠ not interchangeable; ← new for old; → old for new

REF.No	Part No.	Description	Q'ty	S.No.	I/C	REMARKS	Weight (kgf)	Weight (lb)
010	76539-34510	HOLDER PULLEY LH	1	←=22057			1.77	3.894
010	76539-34514	HOLDER PULLEY LH	1	≧=30001	≠		0	0
010	76539-34515	HOLDER PULLEY LH	1	≧=34841	←		2.28	5.016
020	76539-34520	HOLDER PULLEY RH	1	←=22057			1.82	4.004
020	76539-34524	HOLDER PULLEY RH	1	≧=30001	≠		0	0
020	76539-34525	HOLDER PULLEY RH	1	≧=34841	←		2.4	5.28
030	76539-34320	HOLDER PLATE	2	←=34840			0	0
030	76539-34323	HOLDER PLATE	2	≧=34841	←		0.25	0.55
040	01133-51225	BOLT	8				0.038	0.0836
050	76539-34530	SHAFT BLADE RH	1	←=11691			0.42	0.924
050	76539-34540	SHAFT BLADE RH	1	≧=20001	≠		0	0
050	76539-34542	SHAFT BLADE RH	1	≧=30001	≠		0.515	1.133
050	76539-34544	SHAFT BLADE RH	1	≧=34841	≠		0.51	1.122
060	76539-34560	SHAFT BLADE LH	1	←=11691			0.4	0.88
060	76539-34550	SHAFT BLADE LH	1	≧=20001	≠		0.43	0.946
060	76539-34552	SHAFT BLADE LH	1	≧=30001	≠		0.5	1.1
060	76539-34554	SHAFT BLADE LH	1	≧=34841	≠		0.48	1.056
070	08101-06205	BEARING BALL	4				0.14	0.308
080	70722-34120	SEAL OIL	2				0.025	0.055
090	04611-00520	CIR CLIP INTERNAL	4				0.009	0.0198
100	09500-35528	SEAL OIL	2	←=34409			0.017	0.0374
100	70725-34162	SEAL OIL	2	≧=34410	←		0.024	0.0528
110	06613-10675	NIPPLE GREASE	1				0.003	0.0066
120	76539-33570	PULLEY SIDE RH	1				1.71	3.762
130	76539-33580	PULLEY SIDE LH	1				1.7	3.74
140	05712-00722	KEY FEATHER	2				0.009	0.0198
150	70721-34560	WASHER PLAIN	2				0.01	0.022
160	70725-33600	WASHER SPRING	2	←=34840			0.015	0.033
160	04512-60160	WASHER SPRING	2	≧=34841	≠		0.01	0.022
170	70725-33560	NUT	2	←=34840			0.012	0.0264
170	02172-50160	NUT	2	≧=34841	≠		0.017	0.0374
180	76539-34132	PIPE EXTENSION	1				0.01	0.022
190	03410-50606	SCREW SET	1				0.001	0.0022
200	06613-10675	NIPPLE GREASE	1				0.003	0.0066
210	76539-34150	BOSS BLADE	2	←=11691			0.28	0.616
210	76539-34160	BOSS BLADE	2	≧=20001	≠		0.42	0.924
210	76539-34150	BOSS BLADE	2	≧=30001	≠		0.28	0.616
220	04612-00220	CIRCLIP EXTERNAL	2				0.001	0.0022
230	76529-34330	BLADE	2				1.45	3.19
240	76550-34350	RETAINER BLADE	4				0.075	0.165
250	76539-34390	JOINT BLADE BOSS	2				0	0
260	76539-34372	BOLT LOCKING BLADE	2				0.05	0.11

TENSION PULLEY

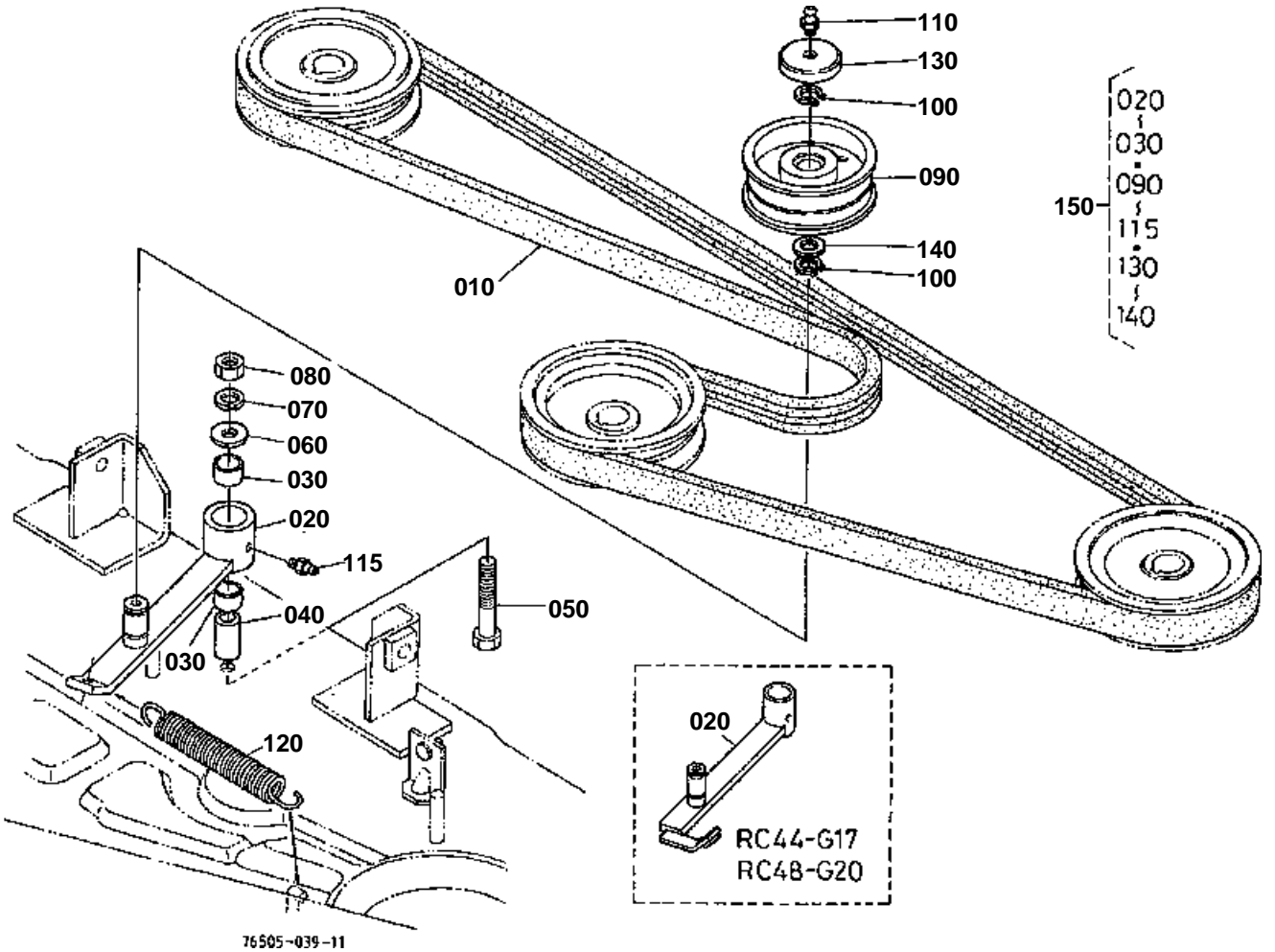

76505-039-11



# TENSION PULLEY

↔ Interchangeable; ≠ not interchangeable; ← new for old; → old for new

REF.No	Part No.	Description	Q'ty	S.No.	I/C	REMARKS	Weight (kgf)	Weight (lb)
010	76529-34710	BELT MULTI	1			110IN	0.91	2.002
020	76539-34733	ARM TENSION	1	≤32557			0.55	1.21
020	76539-34734	ARM TENSION	1	≥32558	≠		0.6	1.32
030	08511-02020	BUSH	2				0.01	0.022
040	76539-34780	COLLAR TENSION	1				0.06	0.132
050	01173-51270	BOLT	1				0.067	0.1474
060	04015-60120	WASHER PLAIN	1				0.022	0.0484
070	04512-60120	WASHER SPRING	1				0.005	0.011
080	02172-50120	NUT	1				0.01	0.022
090	76539-34880	ASSY PULLEY TENSION	1	≤32557			0	0
090	76539-34883	ASSY PULLEY TENSION	1	≥32558	←		0.42	0.924
100	04612-00170	CIRCLIP EXTERNAL	2				0.001	0.0022
110	06613-10675	NIPPLE GREASE	2	≤32557			0.003	0.0066
110	76539-12100	NIPPLE GREASE	1	≥32558	≠		0.005	0.011
115	76543-12100	NIPPLE GREASE	1	≥32558			0.003	0.0066
120	76539-34750	SPRING TENSION	1				0.18	0.396
130	76539-34790	COVER TENSION	1	≥32558			0.03	0.066
140	76539-34800	SEAL BEARING	1	≥32558			0.001	0.0022
150	76539-99410	KIT PULLEY TENSION	1				0.98	2.156





**MOWER DECK**

↔ Interchangeable; ≠ not interchangeable; ← new for old; → old for new

REF.No	Part No.	Description	Q'ty	S.No.	I/C	REMARKS	Weight (kgf)	Weight (lb)
010	76507-41160	DECK MOWER	1	<=11042			0	0
010	76507-41163	DECK MOWER	1	>=11043	≠		46	101.2
010	76507-41165	DECK MOWER	1	>=20001	≠		81	178.2
010	76507-41167	DECK MOWER	1	>=30001	≠		45	99
020	76507-41180	COVER LH	1				0.5	1.1
030	04013-50080	WASHER PLAIN	4				0	0
040	04512-60080	WASHER SPRING	4				0.002	0.0044
050	02114-50080	NUT	4				0.005	0.011
060	76507-41200	COVER RH	1				1.3	2.86
080	66071-61780	LABEL CAUTION	1				0.005	0.011
090	66071-61790	LABEL CAUTION	1				0.002	0.0044
090	76530-11420	LABEL CAUTION	1			[CA]	0.001	0.0022
100	76508-47160	LABEL CUTTING HEIGHT	1	<=22057			0.002	0.0044
100	76508-47162	LABEL CUTTING HEIGHT	1	>=30001	≠		0.001	0.0022
100	76507-11490	LABEL CUTTING HEIGHT	1	<=22057		[CA]	0.001	0.0022
100	76507-11492	LABEL CUTTING HEIGHT	1	>=30001	≠	[CA]	0.001	0.0022
110	76539-34570	LABEL BLADE	1				0.003	0.0066
110	76507-11340	NAME PLATE BLADE	1			[CA]	0.003	0.0066
120	76529-41100	BAR FRONT LH	1	>=30001			0.65	1.43
130	76529-41120	BAR FRONT RH	1	>=30001			0.7	1.54
140	01053-50516	BOLT	8	>=30001			0.003	0.0066
150	04512-50050	WASHER SPRING	8	>=30001			0	0
160	04013-60050	WASHER PLAIN	8	>=30001			0.001	0.0022
170	76547-71202	NAME PLATE	1	>=11332			0	0
180	76539-34830	LABEL GREASE UP	1	>=32558			0.002	0.0044
180	76539-34840	LABEL GREASE UP	1	>=32558		[CA]	0.002	0.0044
190	76543-41100	CLAMP	2			OPTION	0.06	0.132

# FRONT WHEEL

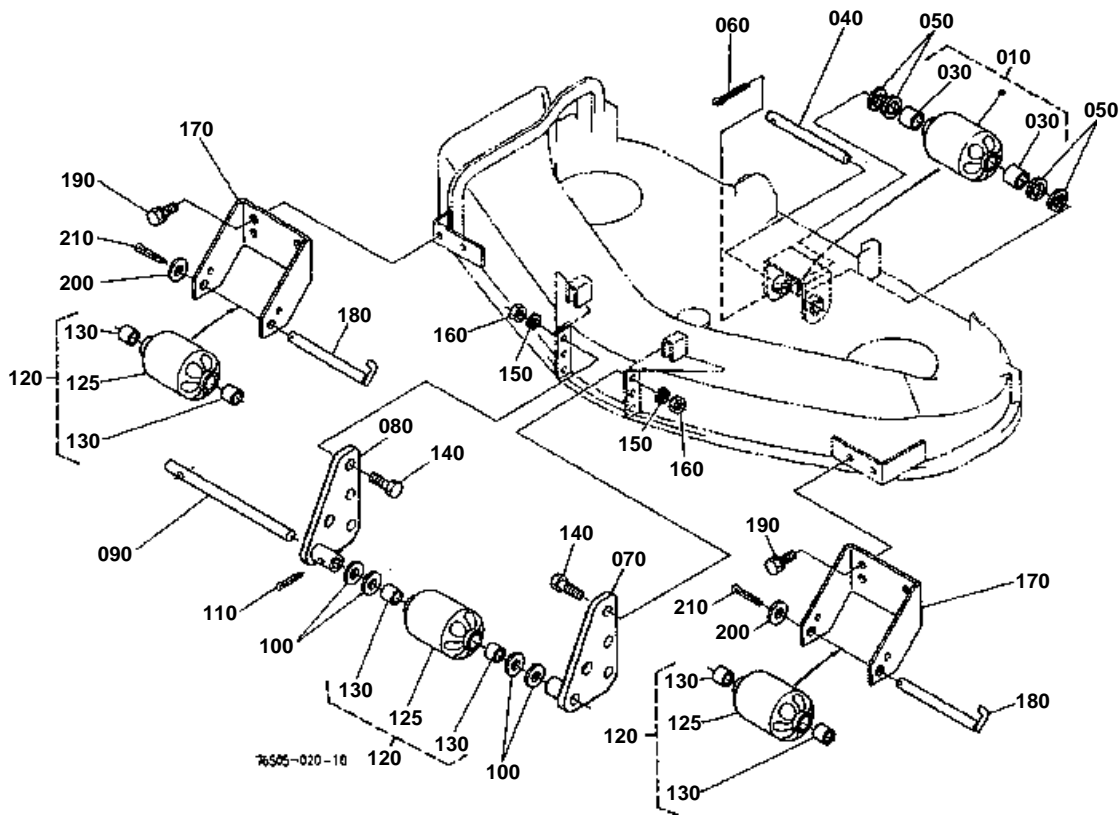

FRONT WHEEL

010 70722-4615-0

040 70720-4618-3

050 04011-50120

060 05511-50425

070 76508-4481-0

080 76508-4482-0

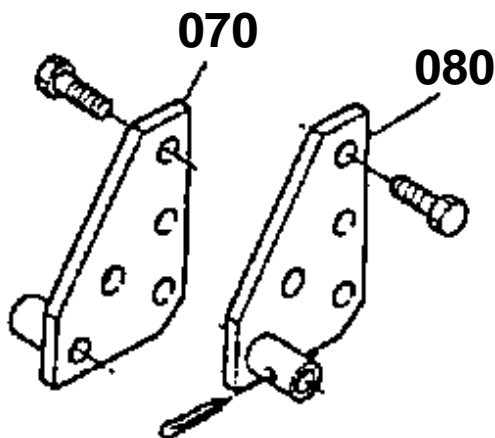
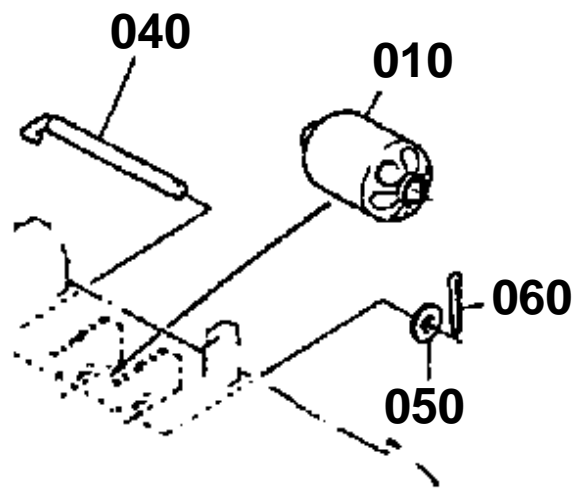

76505-821-10

**FRONT WHEEL**

↔ Interchangeable; ≠ not interchangeable; ← new for old; → old for new

REF.No	Part No.	Description	Q'ty	S.No.	I/C	REMARKS	Weight (kgf)	Weight (lb)
010	70722-46150	ROLLER ANTI-SCALP	1	≤11691			0	0
010	76507-46250	ASSY ROLL.ANTI-SCALP	1	≥20001	←		0.28	0.616
030	08511-01220	BUSH	2				0.004	0.0088
040	70720-46183	PIN GAUGE WHEEL	1	≤20164			0.125	0.275
040	76505-46182	PIN GAUGE WHEEL	1	≥20165	≠		0.22	0.484
050	04011-50120	WASHER PLAIN	1	≤20164			0.005	0.011
050	04011-50120	WASHER PLAIN	4	≥20165			0.005	0.011
060	05511-50425	PIN SPLIT	1	≤20614			0.003	0.0066
060	05511-50530	PIN SPLIT	1	≥20615	≠		0.006	0.0132
070	76508-44810	BRACKET LH	1	≤20614			0.54	1.188
070	76508-44812	BRACKET LH	1	≥20615	≠		0.54	1.188
080	76508-44820	BRACKET RH	1	≤20614			0.54	1.188
080	76508-44822	BRACKET RH	1	≥20615	≠		0.5	1.1
090	76505-46180	PIN GAUGE WHEEL	1	≤20234			0	0
090	76505-46182	PIN GAUGE WHEEL	1	≥20235	≠		0.22	0.484
100	04011-50120	WASHER PLAIN	4				0.005	0.011
110	05511-50525	PIN SPLIT	1	≤20234			0.005	0.011
110	05511-50530	PIN SPLIT	1	≥20235	≠		0.006	0.0132
120	76559-46250	ASSY ROLL.ANTI-SCALP	3				0.38	0.836
125	70722-46150	ASSY ROLLER ANTI-SCA	3				0	0
130	08511-01220	BUSH	6				0.004	0.0088
140	01173-51030	BOLT	6				0.023	0.0506
150	04512-60100	WASHER SPRING	6				0.002	0.0044
160	02118-50100	NUT	6				0.005	0.011
170	76550-46110	STAY ROLLER	2				0.71	1.562
180	70720-46183	PIN GAUGE WHEEL	2				0.125	0.275
190	01133-51025	BOLT	4				0.023	0.0506
200	04011-50120	WASHER PLAIN	2				0.005	0.011
210	05511-50425	PIN SPLIT	2				0.003	0.0066

REAR WHEEL

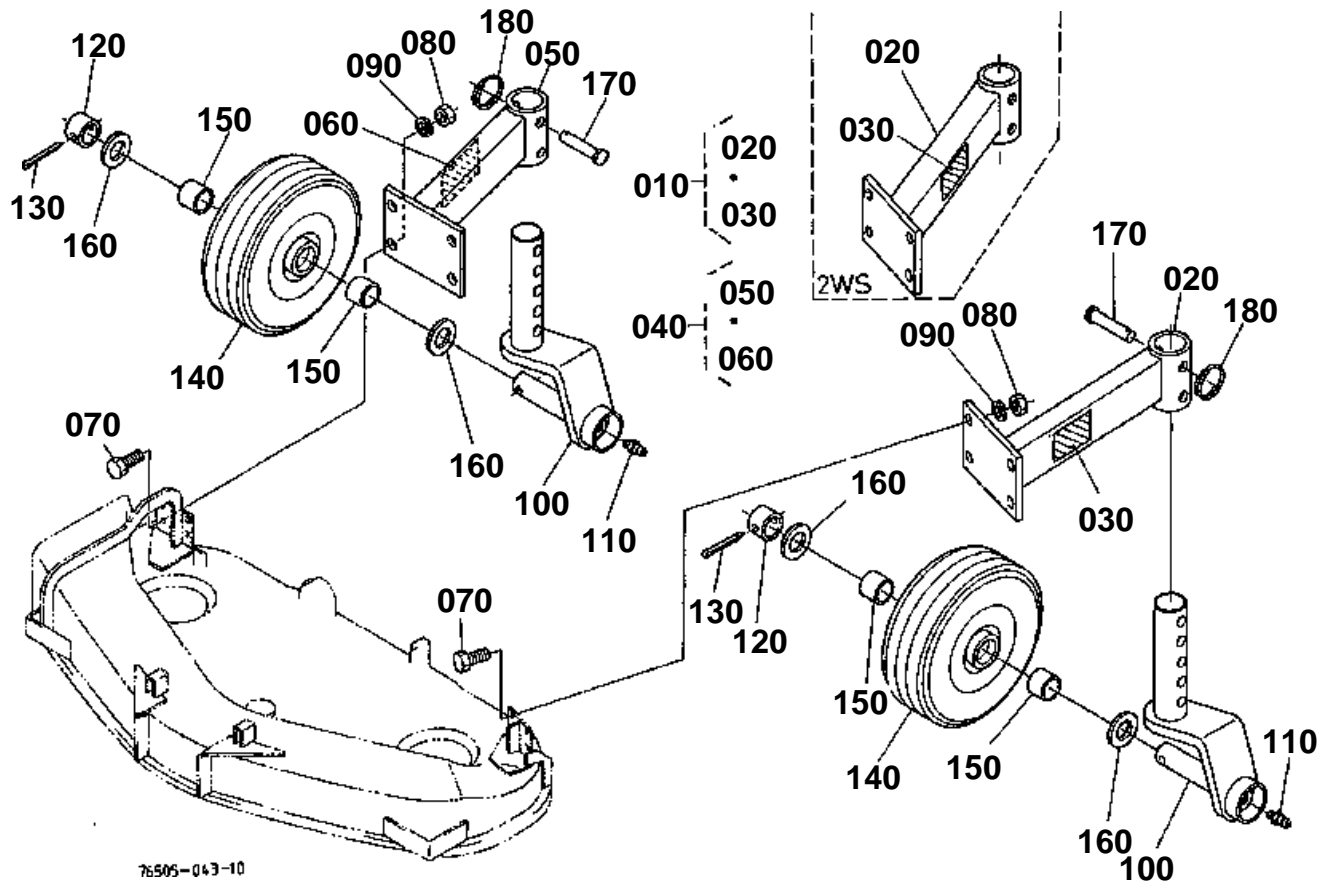

76505-043-10

190 09220-20284

200 04611-00280

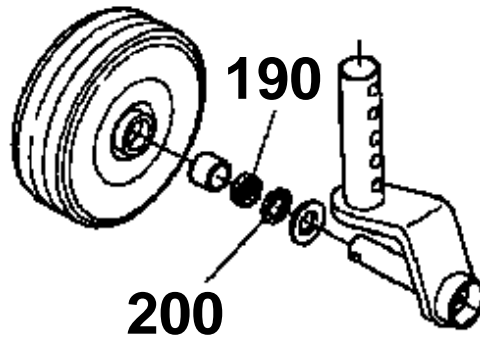

76505-808-10

**REAR WHEEL**

↔ Interchangeable; ≠ not interchangeable; ← new for old; → old for new

REF.No	Part No.	Description	Q'ty	S.No.	I/C	REMARKS	Weight (kgf)	Weight (lb)
010	76507-43320	ASSY SUPPORT R/W LH	1	≤22057		2WS	1.26	2.772
010	76507-43322	ASSY SUPPORT R/W LH	1	≥30001	≠	2WS	1.2	2.64
010	76507-43310	ASSY SUPPORT R/W LH	1	≤22057		4WS	1.26	2.772
010	76507-43312	ASSY SUPPORT R/W LH	1	≥30001	≠	4WS	1.3	2.86
020	76507-43120	SUPPORT REAR WHEEL L	1	≤22057		2WS	1.24	2.728
020	76507-43122	SUPPORT REAR WHEEL L	1	≥30001	≠	2WS	1.2	2.64
020	76507-43110	SUPPORT REAR WHEEL L	1	≤22057		4WS	1.2	2.64
020	76507-43112	SUPPORT REAR WHEEL L	1	≥30001	≠	4WS	1.3	2.86
030	76507-43220	LABEL	1			2WS	0.001	0.0022
030	76507-43210	LABEL	1			4WS	0.001	0.0022
040	76507-43330	ASSY SUPPORT R/W RH	1	≤22057			1.26	2.772
040	76507-43332	ASSY SUPPORT R/W RH	1	≥30001	≠		1.2	2.64
050	76507-43130	SUPPORT REAR WHEEL R	1	≤22057			1.2	2.64
050	76507-43132	SUPPORT REAR WHEEL R	1	≥30001	≠		1.2	2.64
060	76507-43230	LABEL	1				0.001	0.0022
070	01173-51025	BOLT	8				0.021	0.0462
080	02118-50100	NUT	8				0.005	0.011
090	04512-60100	WASHER SPRING	8				0.002	0.0044
100	76507-42150	STAY REAR WHEEL	2				1.78	3.916
110	06613-10675	NIPPLE GREASE	2				0.003	0.0066
120	70712-42140	COLLAR	2				0.068	0.1496
130	05511-50545	PIN SPLIT	2				0.01	0.022
140	76521-42110	FRONT WHEEL	2				1.8	3.96
150	70722-44190	BUSH	4				0.041	0.0902
160	04013-50200	WASHER PLAIN	4				0.02	0.044
170	05122-51050	PIN JOINT	2				0.032	0.0704
180	76550-42190	RING SNAP	2	≤35440			0.004	0.0088
180	70712-51140	RING SNAP	2	≥35441	↔		0.009	0.0198
190	09220-20284	SEAL OIL	4	≤20783			0.004	0.0088
200	04611-00280	CIR CLIP INTERNAL	4	≤20783			0.002	0.0044

DISCHARGE COVER

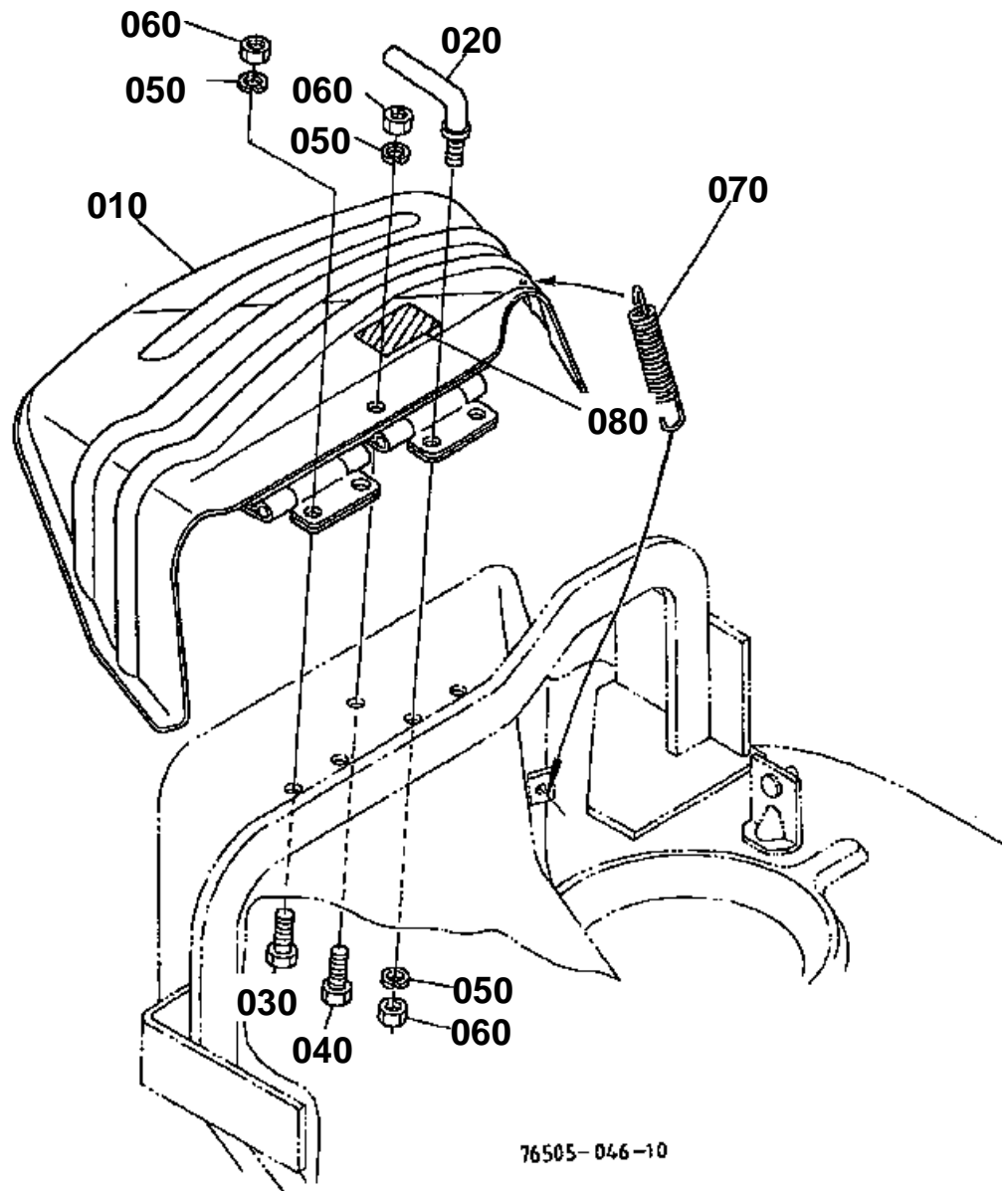

76505-046-10





# DISCHARGE COVER

↔ Interchangeable; ≠ not interchangeable; ← new for old; → old for new

REF.No	Part No.	Description	Q'ty	S.No.	I/C	REMARKS	Weight (kgf)	Weight (lb)
010	76539-47114	COVER CHUTE	1	≤22057			0	0
010	76539-47115	COVER CHUTE	1	≥30001	≠		4.5	9.9
020	70721-47130	STOPPER CHUTE	1				0.05	0.11
030	01173-51025	BOLT	3				0.021	0.0462
040	01173-51028	BOLT	1				0.022	0.0484
050	04512-60100	WASHER SPRING	5				0.002	0.0044
060	02118-50100	NUT	5				0.005	0.011
070	70722-47120	SPRING	1				0.06	0.132
080	76530-11480	LABEL CAUTION	1			[CA]	0.005	0.011

REAR LINKAGE

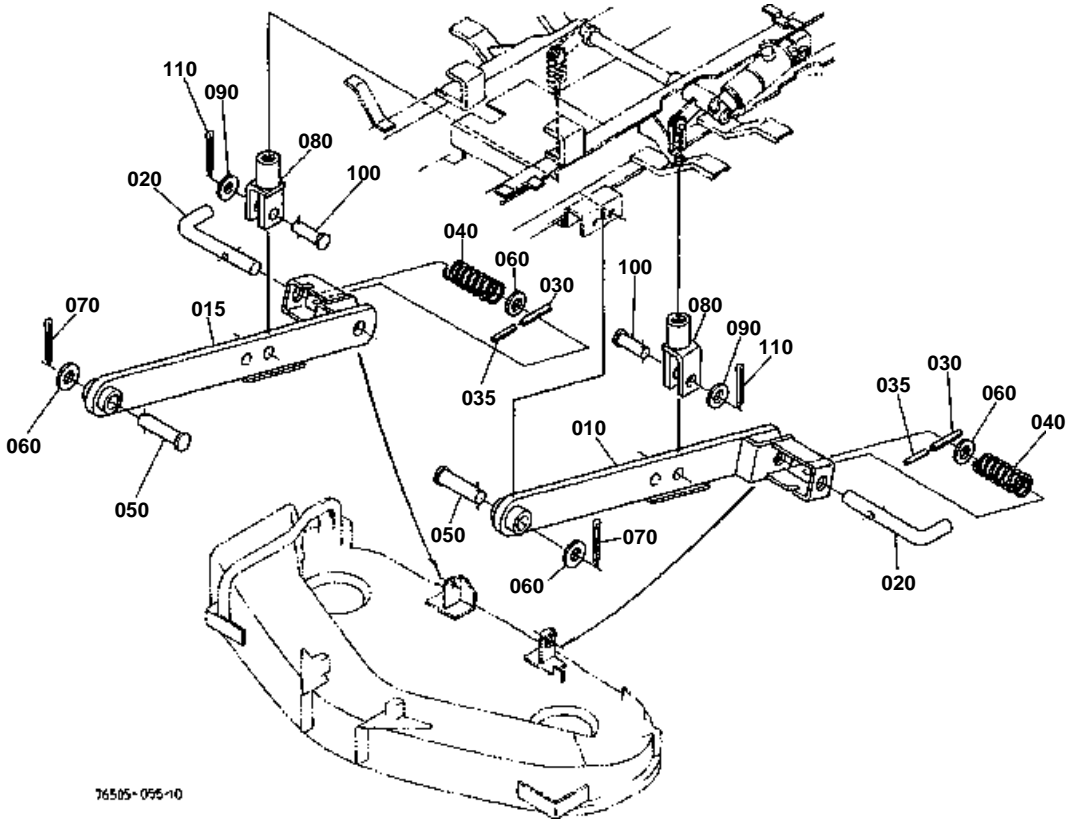

010 76508-5113-0

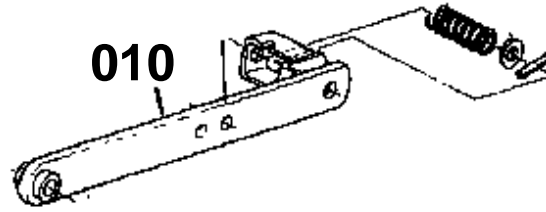

66101-818-10

**REAR LINKAGE**

↔ Interchangeable; ≠ not interchangeable; ← new for old; → old for new

REF.No	Part No.	Description	Q'ty	S.No.	I/C	REMARKS	Weight (kgf)	Weight (lb)
010	76508-51130	LINK REAR LH	2	←=20164			1.3	2.86
010	76508-51132	LINK REAR LH	1	>=20165	←		1.4	3.08
015	76508-51150	LINK REAR RH	1	>=20165			1.4	3.08
020	76539-44650	PIN HINGE	2				0.19	0.418
030	05411-00540	PIN SPRING	2				0.004	0.0088
035	05411-00332	PIN SPRING	2	>=30985			0.001	0.0022
040	76539-44670	SPRING HINGE PIN	2				0.01	0.022
050	05122-51455	PIN JOINT	2				0.068	0.1496
060	04011-50140	WASHER PLAIN	4				0.007	0.0154
070	05511-50430	PIN SPLIT	2				0.004	0.0088
080	76505-51190	ROD LIFT	2				0.16	0.352
090	04013-60120	WASHER PLAIN	2				0.01	0.022
100	05122-51235	PIN JOINT	2				0.034	0.0748
110	05511-50425	PIN SPLIT	2				0.003	0.0066

# FRONT LINKAGE

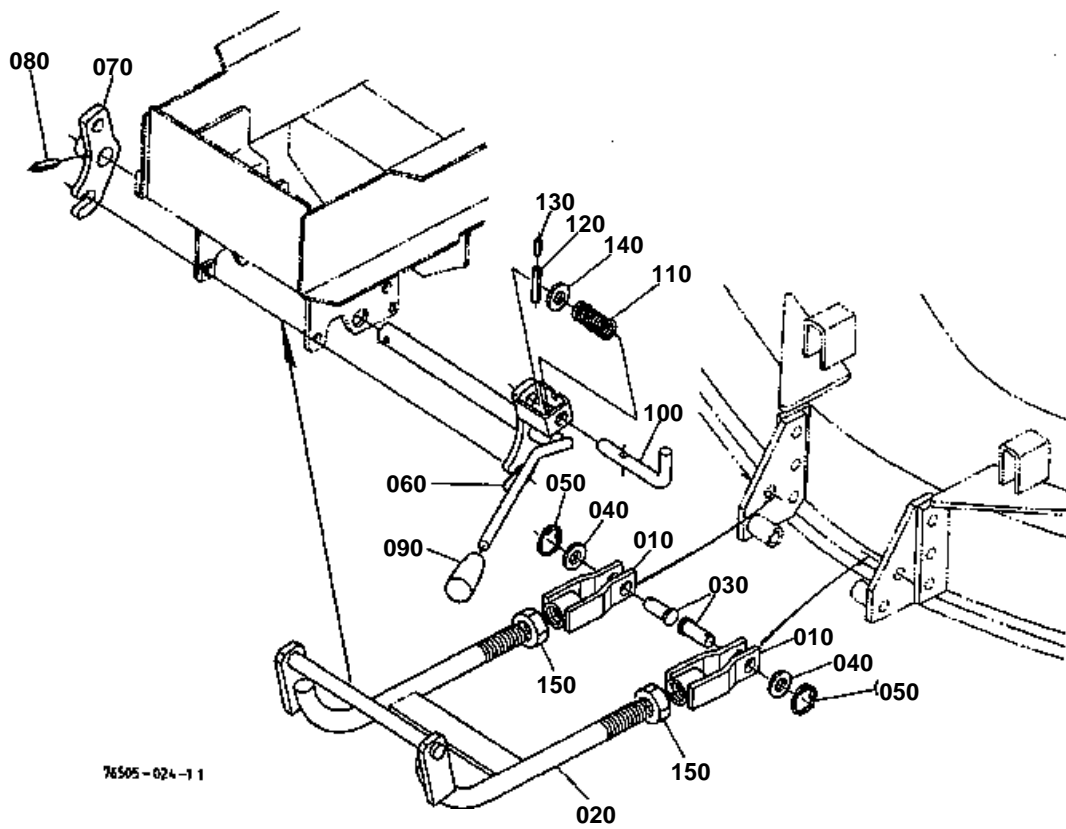

76505-024-1 1

020 76508-4461-0

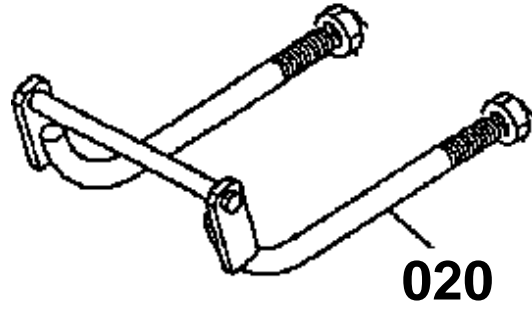

76505-822-10

**FRONT LINKAGE**

↔ Interchangeable; ≠ not interchangeable; ← new for old; → old for new

REF.No	Part No.	Description	Q'ty	S.No.	I/C	REMARKS	Weight (kgf)	Weight (lb)
010	76508-44630	LINK FRONT	2				0.28	0.616
020	76508-44610	LINK FRONT	1	≤=36628			0	0
020	76508-44614	LINK FRONT	1	≥=36629	←		2.54	5.588
030	05122-51435	PIN JOINT	2				0.05	0.11
040	04011-50140	WASHER PLAIN	2				0.007	0.0154
050	70712-51140	RING SNAP	2				0.009	0.0198
060	76508-44580	LEVER LINK FULCRUM	1				1.14	2.508
070	76508-44590	HOLDER LINK	1				0.26	0.572
080	05411-00630	PIN SPRING	1				0.004	0.0088
090	06914-00120	GRIP LEVER	1				0.018	0.0396
100	76539-44540	PIN HINGE	1				0.15	0.33
110	76539-44560	SPRING HINGE PIN	1				0.005	0.011
120	05411-00540	PIN SPRING	1				0.004	0.0088
130	05411-00320	PIN SPRING	1				0.001	0.0022
140	04011-50140	WASHER PLAIN	1				0.007	0.0154
150	02172-50200	NUT	2				0.03	0.066

# MOWER ASSIST SPRING

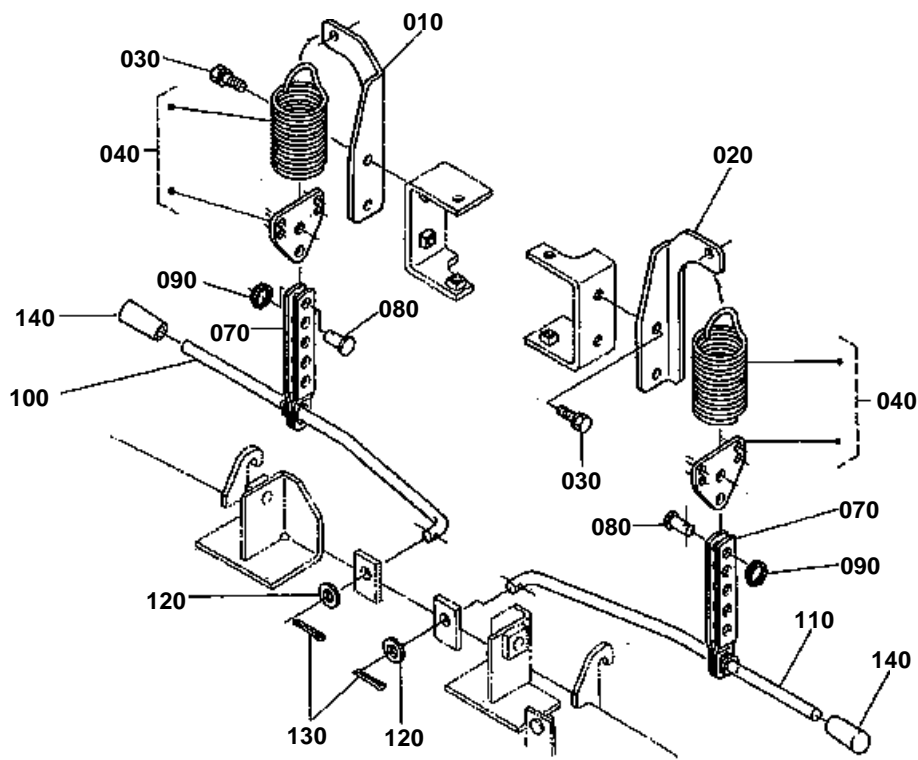

76505-027-10





**MOWER ASSIST SPRING**  
S.No.;>=30001

↔ Interchangeable; ≠ not interchangeable; ← new for old; → old for new

REF.No	Part No.	Description	Q'ty	S.No.	I/C	REMARKS	Weight (kgf)	Weight (lb)
010	76508-15100	STAY RH	1				0.5	1.1
020	76508-15110	STAY LH	1				0.5	1.1
030	01123-50818	BOLT	4				0.012	0.0264
040	76508-15410	ASSY SPRING	2				0.57	1.254
070	76508-15300	ROD	2				0.17	0.374
080	05122-51022	PIN JOINT	2				0.014	0.0308
090	76550-42190	RING SNAP	2				0.004	0.0088
100	76508-15200	LEVER RH	1				0.44	0.968
110	76508-15210	LEVER LH	1				0.44	0.968
120	04011-50120	WASHER PLAIN	2				0.005	0.011
130	05511-50322	PIN SPLIT	2				0.002	0.0044
140	06914-00120	GRIP LEVER	2				0.018	0.0396



# ACCESSORIES AND SERVICE PARTS

↔ Interchangeable; ≠ not interchangeable; ← new for old; → old for new

REF.No	Part No.	Description	Q'ty	S.No.	I/C	REMARKS	Weight (kgf)	Weight (lb)
015	76505-71116	MANUAL INSTRUCTION	1				0.07	0.154
020	76529-99000	KIT BLADE	1			REF.No.030	4.38	9.636
030	76529-34330	BLADE	3				1.45	3.19