

Instructions for Parts Books

The heading at the top of the page will be the same for the picture of the parts as it is for the page with the part numbers.

Definition of column headings on part number pages:

REF.No → The number referring to the part on the picture page of the parts book.

Part No. → The number assigned to this part at the time of printing the parts book.

Description → Description of part.

Q'ty → Quantity of part used on that page.

S.No. → Serial number range of the equipment that this part will fit.

>= Your serial number should be greater than or equal to the number shown.

<= Your serial number should be lesser than or equal to the serial number shown.

I/C → Interchangeability of part shown.

↔ The part shown will work for the older and later serial number.

The part shown is not interchangeable with the other serial number.

← new for old

→ old for new

Remarks → Notes about this particular part. Sometimes this may say except [FR] or [CA]

Note about Country Codes:

The parts books we use in the United States of America may also contain information about a part that would be different in another country. It is important that you are aware of the country codes in some instances.

Symbol	Country
A	United States of America
CA	Canada
FR	France
GR	Greece
PO	Portugal
AU	Australia

If the remarks column says for example EXCEPT [FR] this part works in all countries except France. That means it will work here in the USA.

ALL PRODUCT INDEX
RC72-27B

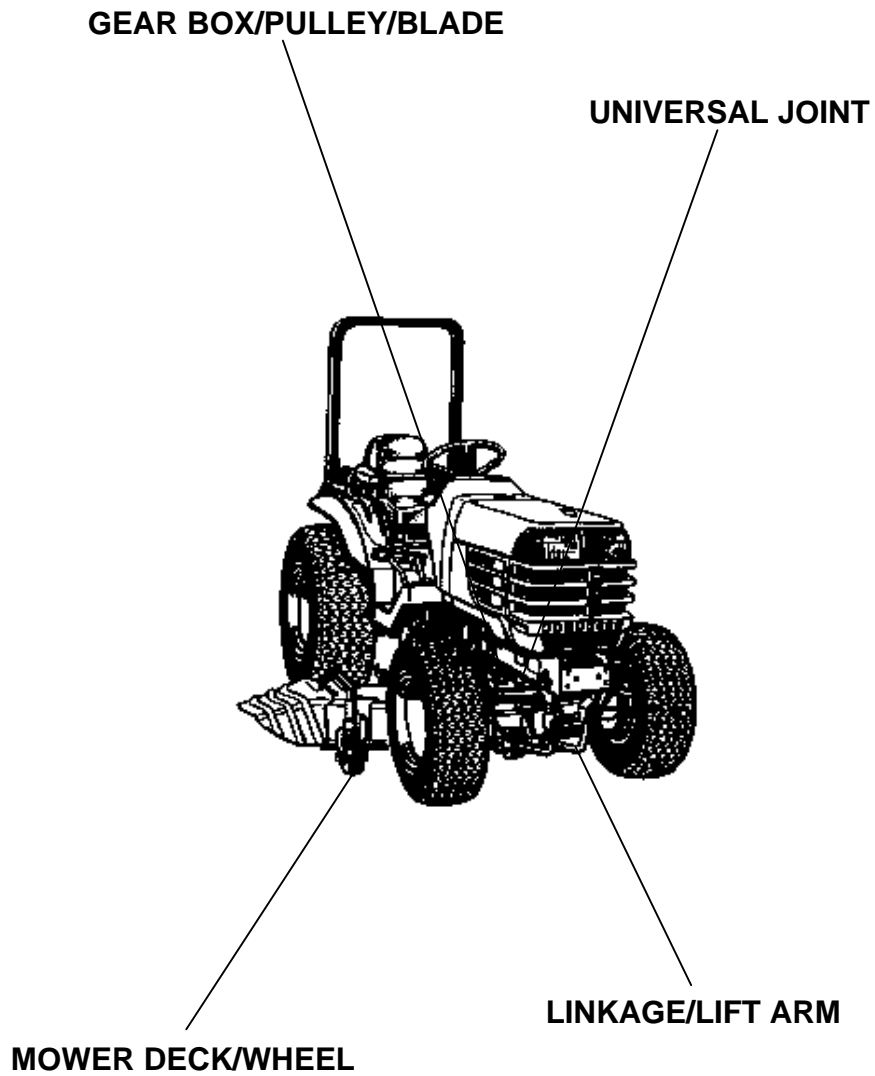

ACCESSORIES

Item	Part No.	Description	Book
UNIVERSAL JOINT	01A001	UNIVERSAL JOINT	100A0034
GEAR BOX/PULLEY/BLADE	01A004	BEVEL GEAR CASE	100A0034
	01A007	PULLEY HOLDER	100A0034
	01A010	BLADE	100A0034
	01A013	TENSION PULLEY	100A0034
MOWER DECK/WHEEL	01A100	MOWER DECK	100A0034
	01A103	FRONT GAUGE WHEEL	100A0034
	01A106	REAR WHEEL	100A0034
	01A109	DISCHARGE COVER	100A0034
LINKAGE/LIFT ARM	01A200	LINKAGE	100A0034
	01A203	LIFT LINKAGE	100A0034
	01A206	LIFT ARM	100A0034
	01A209	LIFT STOPPER	100A0034
ACCESSORIES	01A300	ACCESSORIES AND SERVICE PARTS	100A0034

UNIVERSAL JOINT

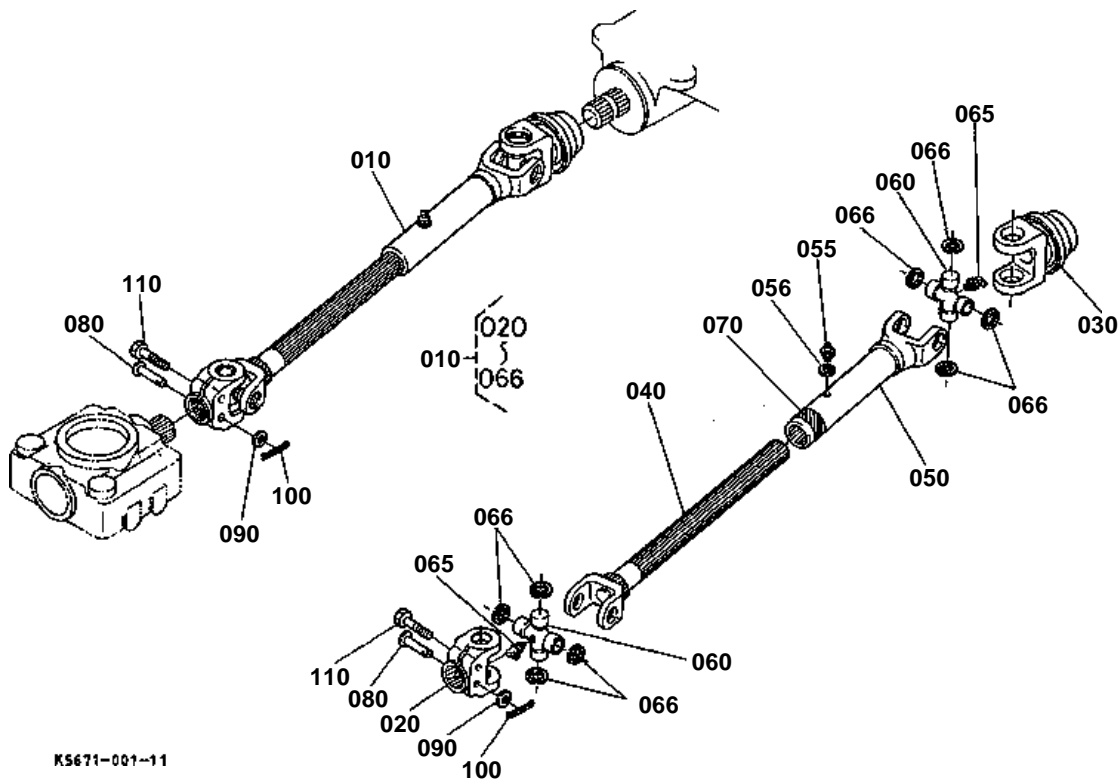

K5671-001-11



UNIVERSAL JOINT

↔ Interchangeable; ≠ not interchangeable; ← new for old; → old for new

REF.No	Part No.	Description	Q'ty	S.No.	I/C	REMARKS	Weight (kgf)	Weight (lb)
010	K5671-32010	JOINT UNIVERSAL	1				3.52	7.744
020	K5671-31130	YOKE PTO	1				0.4	0.88
030	K5671-31150	YOKE QUICK	1				0.54	1.188
040	K5671-31140	SHAFT YOKE	1				1.48	3.256
050	K5671-31170	YOKE SLEEVE	1				0.65	1.43
055	06613-10675	NIPPLE GREASE	1				0.003	0.0066
056	04012-50060	WASHER PLAIN	1				0.001	0.0022
060	K5671-31180	ASSY JOINT CROSS	2				0.23	0.506
065	76508-31210	NIPPLE GREASE	2				0.05	0.11
066	76508-32120	RING SNAP	8				0.01	0.022
070	76550-31150	MARK	1				0.001	0.0022
080	05122-50845	PIN JOINT	1				0.018	0.0396
090	04012-50080	WASHER PLAIN	1				0.001	0.0022
100	05511-50218	PIN SPLIT	1				0.001	0.0022
110	01123-50840	BOLT	1				0.018	0.0396

BEVEL GEAR CASE

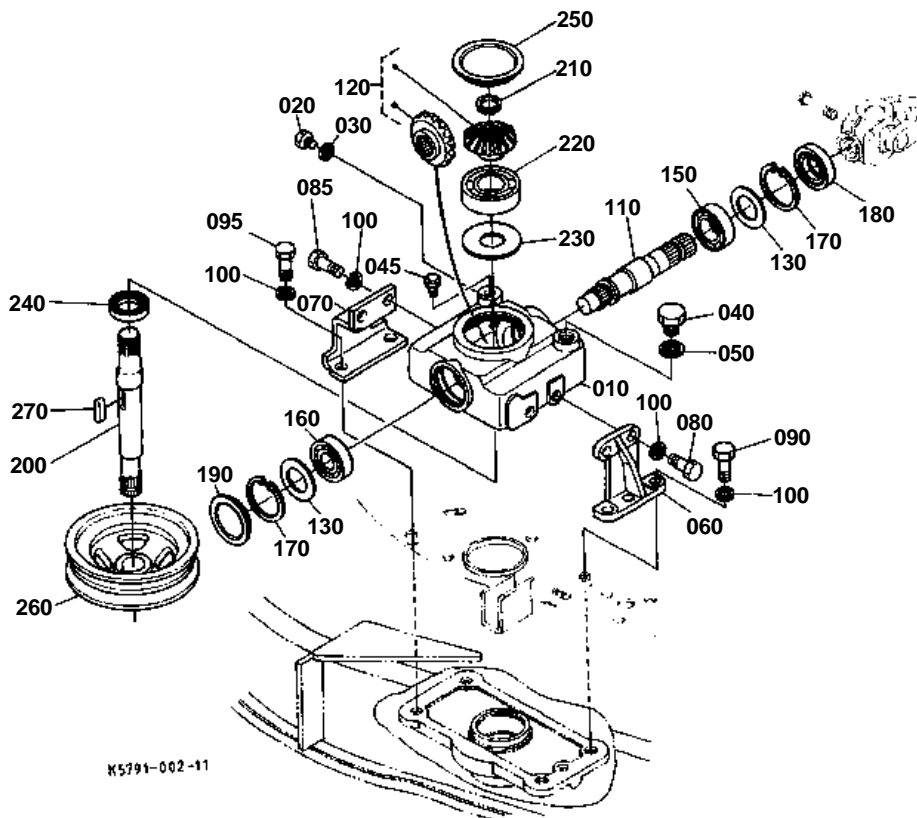

010 K5761-3311-4

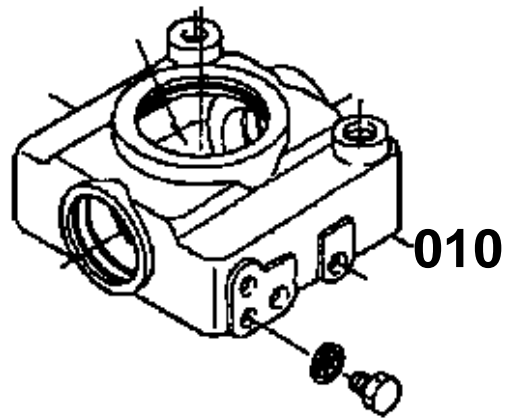

K5791-800-10



↔ Interchangeable; ≠ not interchangeable; ← new for old; → old for new

REF.No	Part No.	Description	Q'ty	S.No.	I/C	REMARKS	Weight (kgf)	Weight (lb)
010	K5761-33115	CASE BEVEL GEAR	1	←=10479			3.82	8.404
020	01153-50812	BOLT	2				0.008	0.0176
030	04717-00800	WASHER WITH RUBBER	2				0.001	0.0022
040	06331-35016	PLUG	1				0.04	0.088
045	K5761-33250	PLUG BREATHER	1				0.006	0.0132
050	04711-00300	GASKET	1				0.001	0.0022
060	K5671-33130	STAY BEVEL CASE LH	1				0.45	0.99
070	K5671-33150	STAY BEVEL CASE RH	1				0.462	1.0164
080	K5761-33210	BOLT REAMER	2				0.038	0.0836
085	01133-51225	BOLT	2				0.038	0.0836
090	K5671-33230	BOLT REAMER	2				0.043	0.0946
095	01133-51235	BOLT	2				0.05	0.11
100	04512-60120	WASHER SPRING	4				0.005	0.011
110	K5761-33310	SHAFT PINION	1				0.64	1.408
120	K5671-33320	KIT GEAR BEVEL	1			17-18T	0.45	0.99
130	36330-28420	SHIM	2			0.2MM	0.002	0.0044
130	36330-28410	SHIM	2			0.3MM	0.002	0.0044
150	08101-06205	BEARING BALL	1				0.14	0.308
160	08101-06304	BEARING BALL	1				0.146	0.3212
170	04611-00520	CIR CLIP INTERNAL	2				0.009	0.0198
180	76535-33440	SEAL OIL	1				0.02	0.044
190	63313-32270	CAP	1				0.03	0.066
200	K5671-33503	SHAFT BEVEL GEAR	1				0	0
210	04612-00220	CIR CLIP EXTERNAL	1				0.001	0.0022
220	70712-33550	BEARING BALL	1				0.22	0.484
230	70712-33570	SHIM	1			0.1MM	0.001	0.0022
230	76539-33410	SHIM	1			0.2MM	0.001	0.0022
240	K5761-33540	SEAL OIL	1				0.012	0.0264
250	7C765-51260	CAP	1				0.07	0.154
260	K5671-33520	PULLEY CENTER	1				1.79	3.938
270	05712-00732	KEY FEATHER	1				0.013	0.0286

PULLEY HOLDER

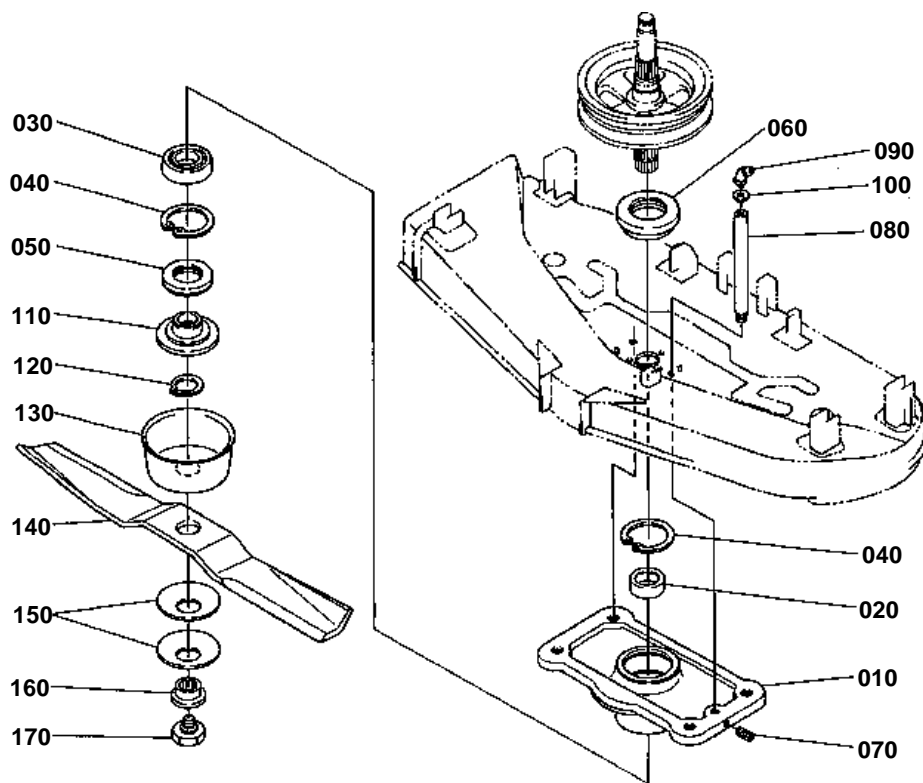

K5791-003-10



PULLEY HOLDER

↔ Interchangeable; ≠ not interchangeable; ← new for old; → old for new

REF.No	Part No.	Description	Q'ty	S.No.	I/C	REMARKS	Weight (kgf)	Weight (lb)
010	K5671-34110	HOLDER CENTER PULLEY	1				2.95	6.49
020	K5671-33590	COLLAR	1				0.034	0.0748
030	08101-06205	BEARING BALL	1				0.14	0.308
040	04611-00520	CIR CLIP INTERNAL	2				0.009	0.0198
050	70725-34162	SEAL OIL	1				0.024	0.0528
060	70722-34120	SEAL OIL	1				0.025	0.055
070	03410-50606	SCREW SET	1				0.001	0.0022
080	76550-34130	PIPE EXTENSION	1				0.035	0.077
090	67111-44250	NIPPLE GREASE	1				0.005	0.011
100	66616-34390	SHIM ADJUSTING	1				0.001	0.0022
110	K5761-34152	BOSS SPLINE	1				0.28	0.616
120	04612-00220	CIR CLIP EXTERNAL	1				0.001	0.0022
130	K5671-34310	COVER DUST	1				0.11	0.242
140	76553-34330	BLADE	1				2	4.4
150	76550-34350	RETAINER BLADE	2				0.075	0.165
160	76539-34392	JOINT BLADE BOSS	1				0.06	0.132
170	76539-34372	BOLT LOCKING BLADE	1				0.05	0.11

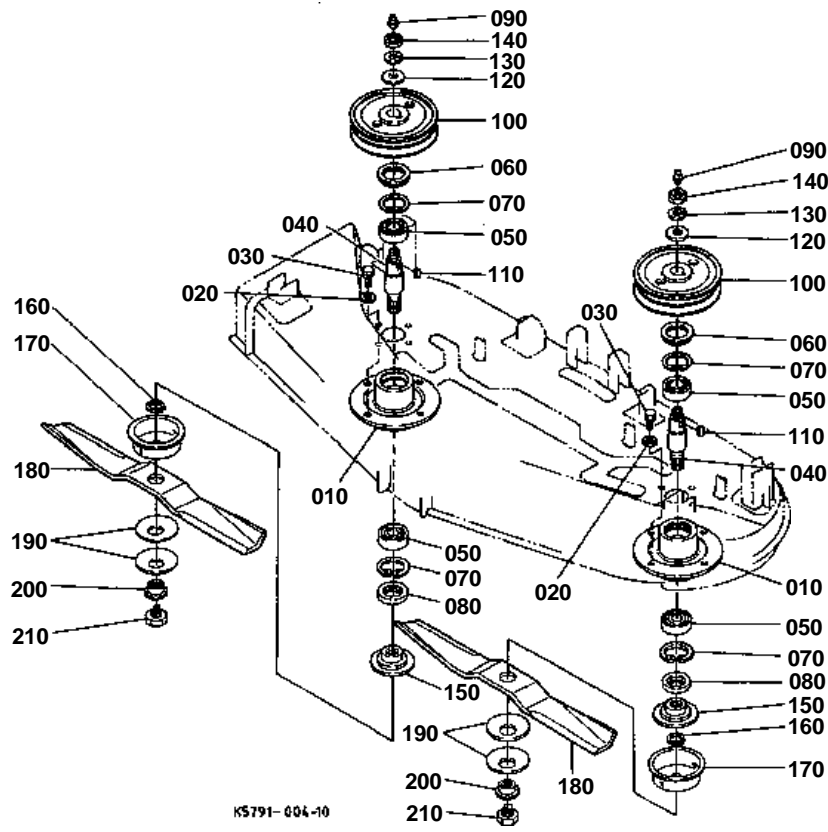

**BLADE**

↔ Interchangeable; ≠ not interchangeable; ← new for old; → old for new

REF.No	Part No.	Description	Q'ty	S.No.	I/C	REMARKS	Weight (kgf)	Weight (lb)
010	K5671-34510	HOLDER SIDE	2				2.4	5.28
020	04013-60120	WASHER PLAIN	8				0.01	0.022
030	01133-51230	BOLT	8				0.04	0.088
040	K5671-34550	SHAFT BLADE	2				0.55	1.21
050	08101-06205	BEARING BALL	4				0.14	0.308
060	70722-34120	SEAL OIL	2				0.025	0.055
070	04611-00520	CIR CLIP INTERNAL	4				0.009	0.0198
080	70725-34162	SEAL OIL	2				0.024	0.0528
090	06613-10675	NIPPLE GREASE	2				0.003	0.0066
100	K5671-33580	PULLEY SIDE	2				1.7	3.74
110	05712-00722	KEY FEATHER	2				0.009	0.0198
120	70721-34560	WASHER PLAIN	2				0.01	0.022
130	04512-60160	WASHER SPRING	2				0.01	0.022
140	02172-50160	NUT	2				0.017	0.0374
150	K5761-34152	BOSS SPLINE	2				0.28	0.616
160	04612-00220	CIR CLIP EXTERNAL	2				0.001	0.0022
170	K5671-34310	COVER DUST	2				0.11	0.242
180	76553-34330	BLADE	2				2	4.4
190	76550-34350	RETAINER BLADE	4				0.075	0.165
200	76539-34392	JOINT BLADE BOSS	2				0.06	0.132
210	76539-34372	BOLT LOCKING BLADE	2				0.05	0.11

TENSION PULLEY

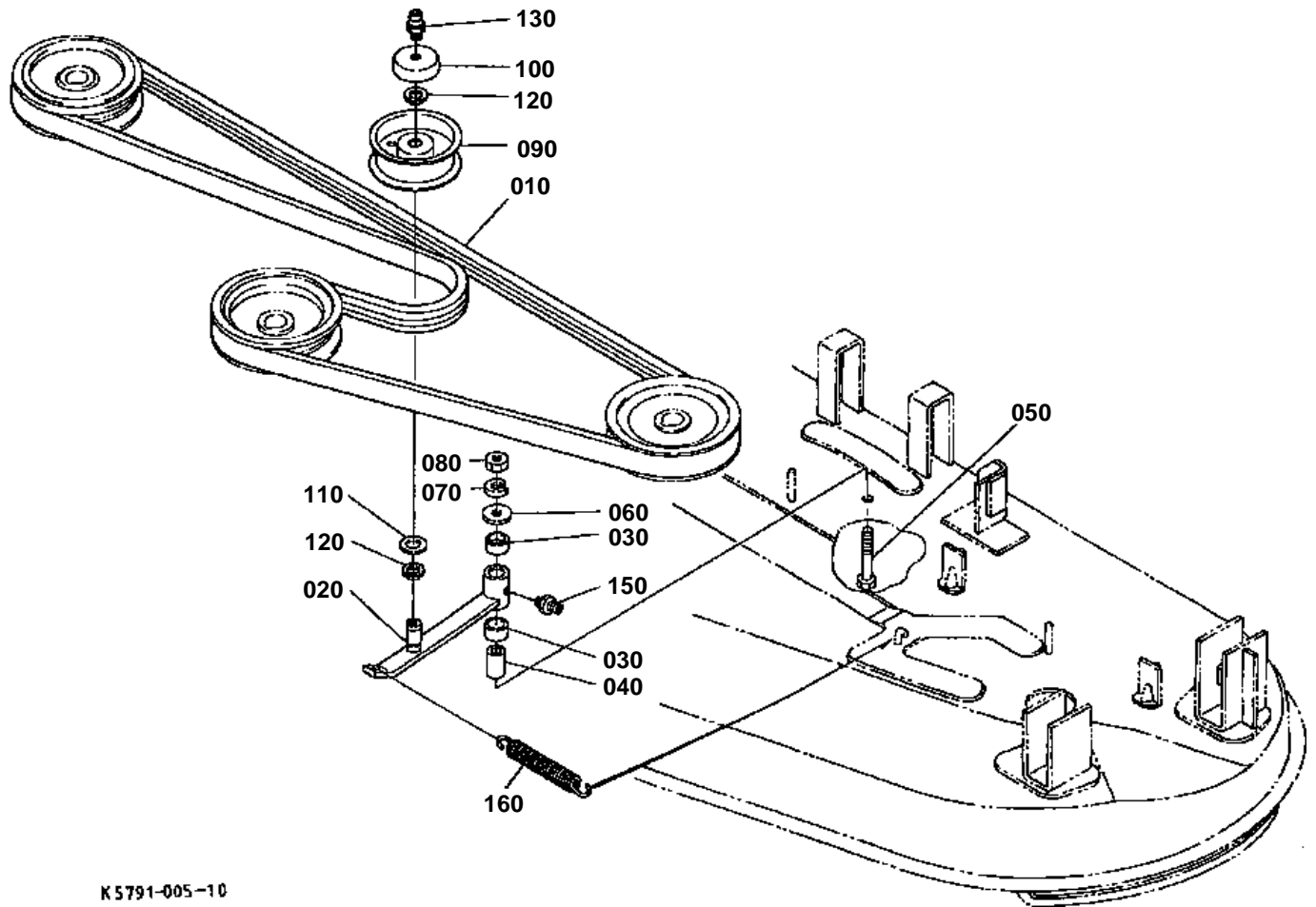

K 5791-005-10



TENSION PULLEY

↔ Interchangeable; ≠ not interchangeable; ← new for old; → old for new

REF.No	Part No.	Description	Q'ty	S.No.	I/C	REMARKS	Weight (kgf)	Weight (lb)
010	K5671-34710	BELT	1				1.05	2.31
020	K5671-34730	ARM	1				0.63	1.386
030	08511-02015	BUSH	2				0.011	0.0242
040	K5761-34780	SPACER TENSION	1				0.068	0.1496
050	01173-51270	BOLT	1				0.067	0.1474
060	04015-60120	WASHER PLAIN	1				0.022	0.0484
070	04512-60120	WASHER SPRING	1				0.005	0.011
080	02172-50120	NUT	1				0.01	0.022
090	76539-34883	COMP.PULLEY TENSION	1				0.42	0.924
100	76539-34790	COVER TENSION	1				0.03	0.066
110	76539-34800	SEAL BEARING	1				0.001	0.0022
120	04612-00170	CIR CLIP EXTERNAL	2				0.001	0.0022
130	76539-12100	NIPPLE GREASE	1				0.005	0.011
150	76543-12100	NIPPLE GREASE	1				0.003	0.0066
160	76539-34750	SPRING TENSION	1				0.18	0.396

MOWER DECK

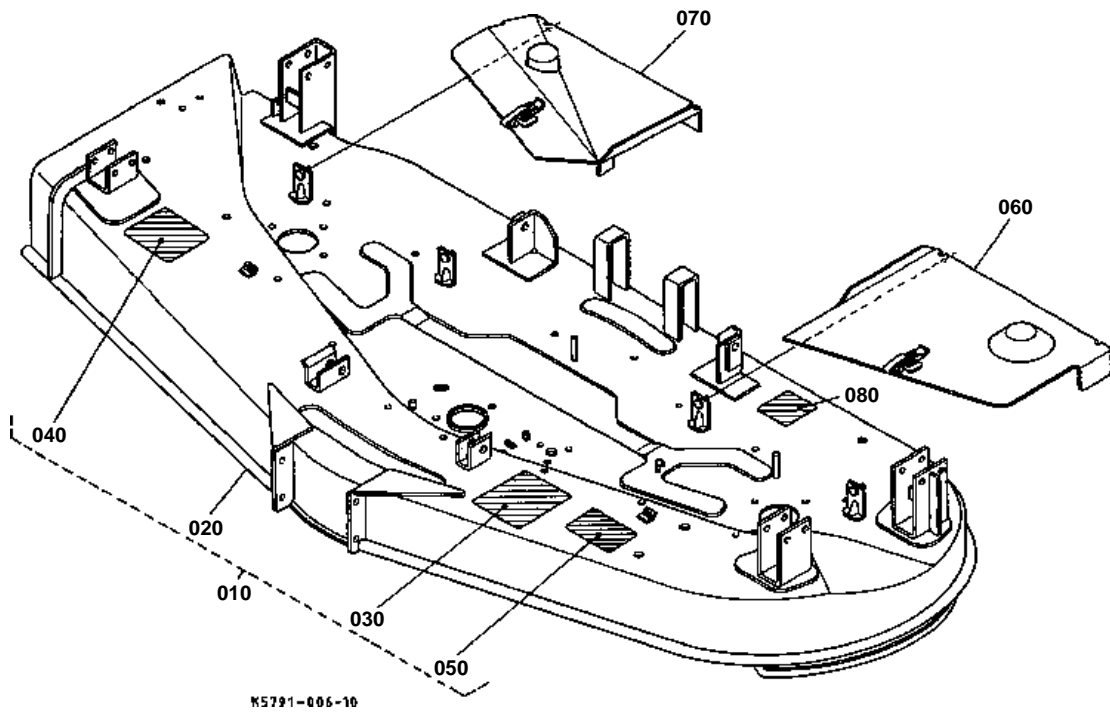



MOWER DECK

↔ Interchangeable; ≠ not interchangeable; ← new for old; → old for new

REF.No	Part No.	Description	Q'ty	S.No.	I/C	REMARKS	Weight (kgf)	Weight (lb)
010	K5791-41100	ASSY DECK MOWER	1				88	193.6
020	K5791-41160	DECK MOWER	1				0	0
030	70720-47154	LABEL CAUTION	1				0.001	0.0022
040	66071-61780	LABEL CAUTION	1				0.005	0.011
050	66071-61790	LABEL CAUTION	1				0.002	0.0044
060	76553-41184	COVER LH	1				2.68	5.896
070	K5791-41200	COVER RH	1				2.48	5.456
080	K5791-41190	LABEL CUTTING HEIGHT	1				0.001	0.0022

FRONT GAUGE WHEEL

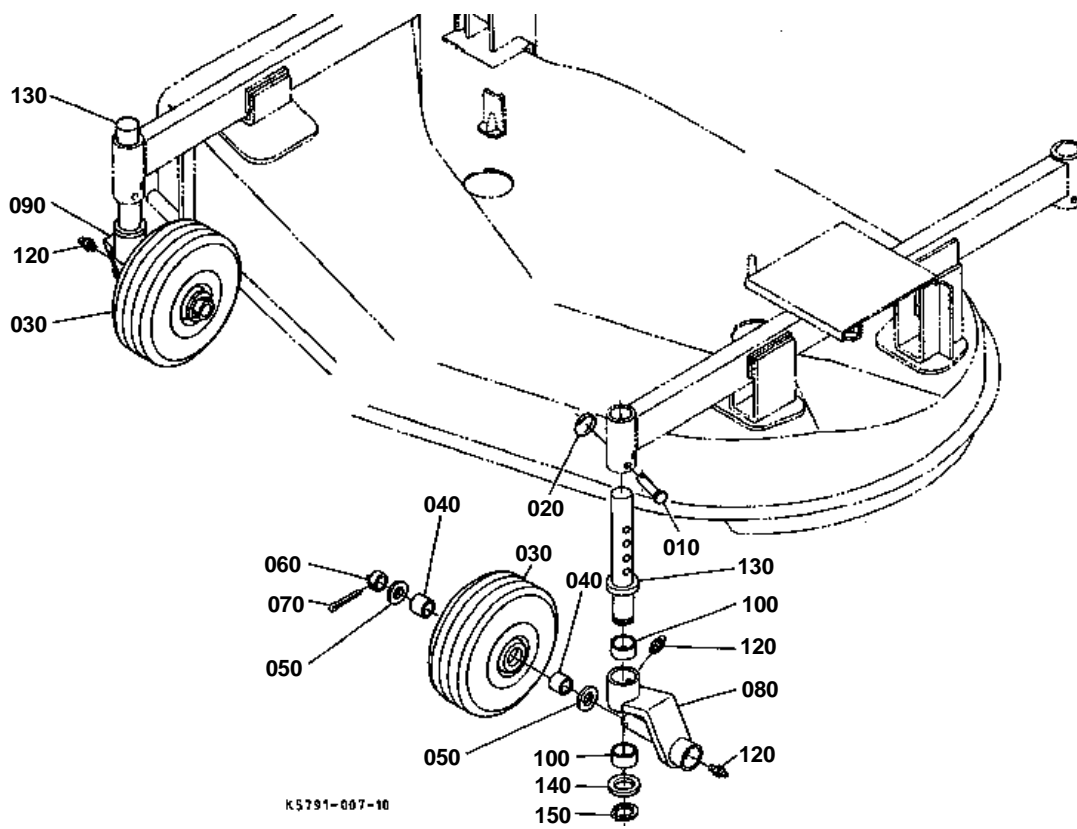



FRONT GAUGE WHEEL

↔ Interchangeable; ≠ not interchangeable; ← new for old; → old for new

REF.No	Part No.	Description	Q'ty	S.No.	I/C	REMARKS	Weight (kgf)	Weight (lb)
010	05122-51050	PIN JOINT	2				0.032	0.0704
020	70712-51140	RING SNAP	2				0.009	0.0198
030	70722-42110	FRONT WHEEL	2				1.9	4.18
040	70722-44190	BUSH	4				0.041	0.0902
050	04013-50200	WASHER PLAIN	4				0.02	0.044
060	70722-42140	COLLAR	2				0.035	0.077
070	05511-50540	PIN SPLIT	2				0.009	0.0198
080	76521-42150	STAY FRONT WHEEL LH	1				1.23	2.706
090	76521-42170	STAY FRONT WHEEL RH	1				1.23	2.706
100	70722-42190	BUSH	4				0.045	0.099
120	06613-10675	NIPPLE GREASE	4				0.003	0.0066
130	76553-43170	SHAFT FRONT WHEEL	2				1.15	2.53
140	70722-43130	COLLAR FRONT WHEEL	2				0.015	0.033
150	04612-00300	CIR CLIP EXTERNAL	2				0.003	0.0066

REAR WHEEL

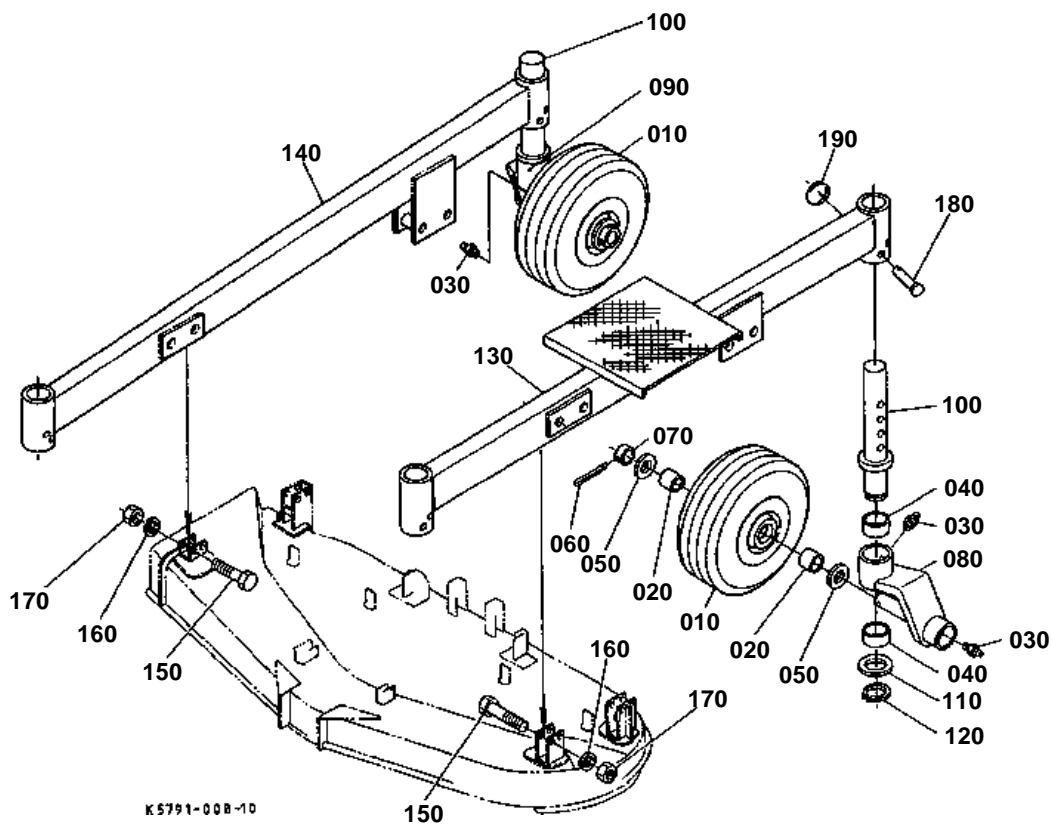

**REAR WHEEL**

↔ Interchangeable; ≠ not interchangeable; ← new for old; → old for new

REF.No	Part No.	Description	Q'ty	S.No.	I/C	REMARKS	Weight (kgf)	Weight (lb)
010	70722-42110	FRONT WHEEL	2				1.9	4.18
020	70722-44190	BUSH	4				0.041	0.0902
030	06613-10675	NIPPLE GREASE	4				0.003	0.0066
040	70722-42190	BUSH	4				0.045	0.099
050	04013-50200	WASHER PLAIN	4				0.02	0.044
060	05511-50540	PIN SPLIT	2				0.009	0.0198
070	70722-42140	COLLAR	2				0.035	0.077
080	76521-42150	STAY FRONT WHEEL LH	1				1.23	2.706
090	76521-42170	STAY FRONT WHEEL RH	1				1.23	2.706
100	76553-43170	SHAFT FRONT WHEEL	2				1.15	2.53
110	70722-43130	COLLAR FRONT WHEEL	2				0.015	0.033
120	04612-00300	CIR CLIP EXTERNAL	2				0.003	0.0066
130	K5791-44110	STAY WHEEL LH	1				6.03	13.266
140	76553-44134	STAY WHEEL RH	1				5.36	11.792
150	01173-51270	BOLT	8				0.067	0.1474
160	04512-60120	WASHER SPRING	8				0.005	0.011
170	02176-50120	NUT	8				0.01	0.022
180	05122-51050	PIN JOINT	2				0.032	0.0704
190	70712-51140	RING SNAP	2				0.009	0.0198

DISCHARGE COVER

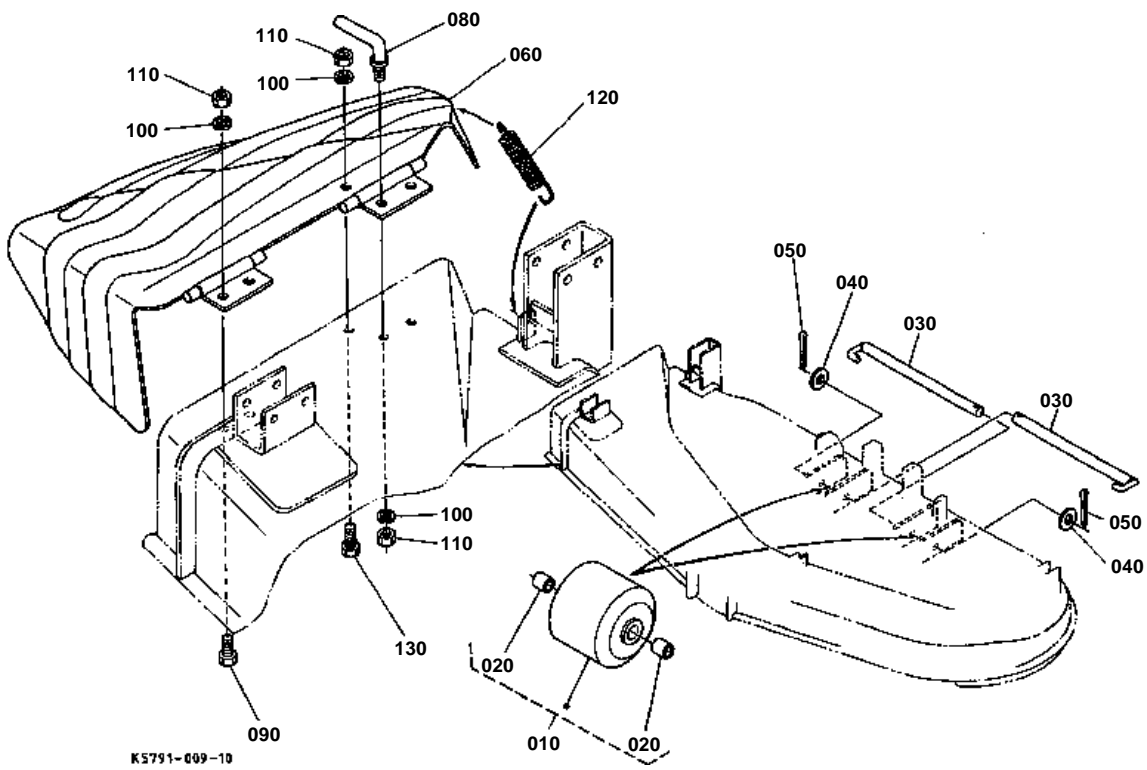



DISCHARGE COVER

↔ Interchangeable; ≠ not interchangeable; ← new for old; → old for new

REF.No	Part No.	Description	Q'ty	S.No.	I/C	REMARKS	Weight (kgf)	Weight (lb)
010	76507-46250	ROLLER ANTI-SCALP	2				0.28	0.616
020	08511-01220	BUSH	4				0.004	0.0088
030	70720-46183	PIN GAUGE WHEEL	2				0.125	0.275
040	04011-50120	WASHER PLAIN	2				0.005	0.011
050	05511-50425	PIN SPLIT	2				0.003	0.0066
060	76550-27113	COVER CHUTE	1				7	15.4
080	70721-47130	STOPPER CHUTE	1				0.05	0.11
090	01173-51025	BOLT	3				0.021	0.0462
100	04512-60100	WASHER SPRING	5				0.002	0.0044
110	02118-50100	NUT	5				0.005	0.011
120	70722-47120	SPRING	1				0.06	0.132
130	01173-51028	BOLT	1				0.022	0.0484

LINKAGE

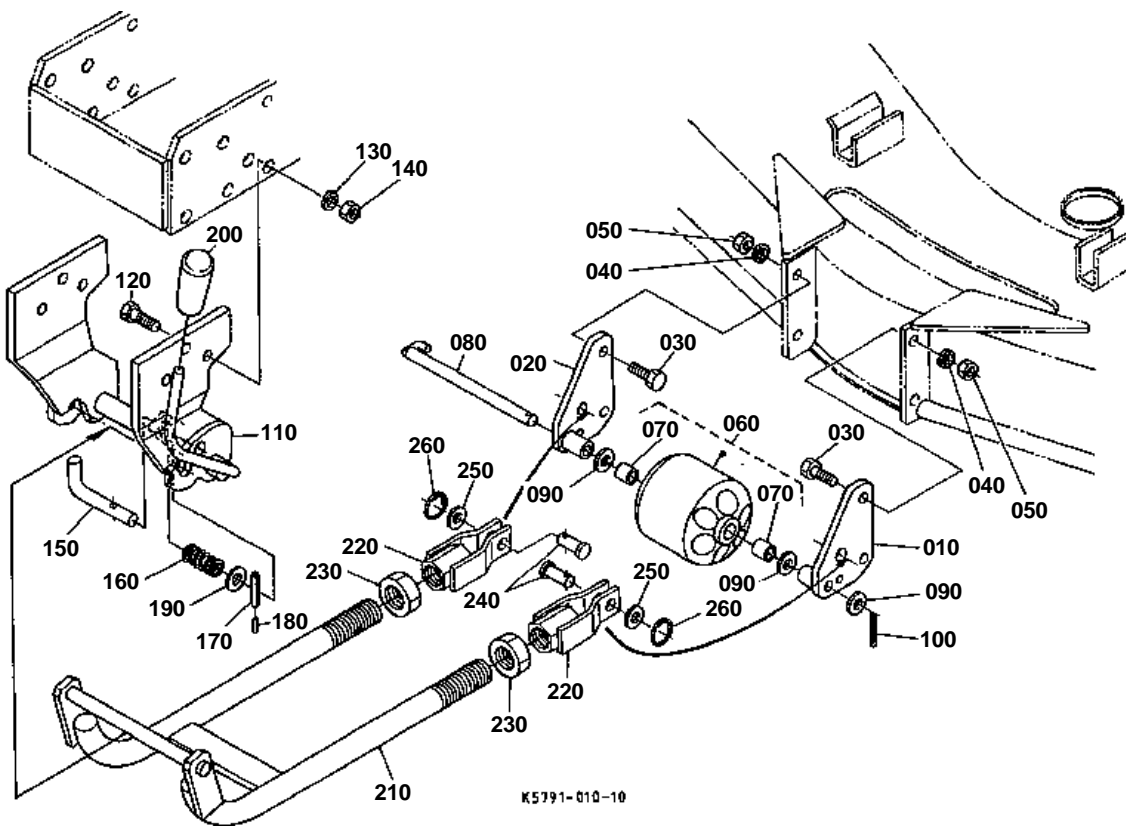



LINKAGE

↔ Interchangeable; ≠ not interchangeable; ← new for old; → old for new

REF.No	Part No.	Description	Q'ty	S.No.	I/C	REMARKS	Weight (kgf)	Weight (lb)
010	76553-44810	BRACKET LH	1				0.71	1.562
020	76553-44820	BRACKET RH	1				0.71	1.562
030	01173-51030	BOLT	4				0.023	0.0506
040	04512-60100	WASHER SPRING	4				0.002	0.0044
050	02118-50100	NUT	4				0.005	0.011
060	76559-46250	ASSY ROLL.ANTI-SCALP	1				0.38	0.836
070	08511-01220	BUSH	2				0.004	0.0088
080	76539-46180	PIN GAUGE WHEEL	1				0.17	0.374
090	04011-50120	WASHER PLAIN	3				0.005	0.011
100	05511-50425	PIN SPLIT	1				0.003	0.0066
110	K5791-44510	STAY FRONT	1				4.47	9.834
120	01173-51435	BOLT	6				0.056	0.1232
130	04512-60140	WASHER SPRING	6				0.006	0.0132
140	02176-50140	NUT	6				0.014	0.0308
150	76539-44540	PIN HINGE	1				0.15	0.33
160	76539-44560	SPRING HINGE PIN	1				0.005	0.011
170	05411-00540	PIN SPRING	1				0.004	0.0088
180	05411-00320	PIN SPRING	1				0.001	0.0022
190	04011-50140	WASHER PLAIN	1				0.007	0.0154
200	06914-00120	GRIP LEVER	1				0.018	0.0396
210	76553-44616	LINK FRONT	1				4.55	10.01
220	76539-44630	LINK FRONT	2				0.43	0.946
230	76539-44660	NUT LOCK	2				0.045	0.099
240	05122-51435	PIN JOINT	2				0.05	0.11
250	04011-50140	WASHER PLAIN	2				0.007	0.0154
260	70712-51140	RING SNAP	2				0.009	0.0198

LIFT LINKAGE

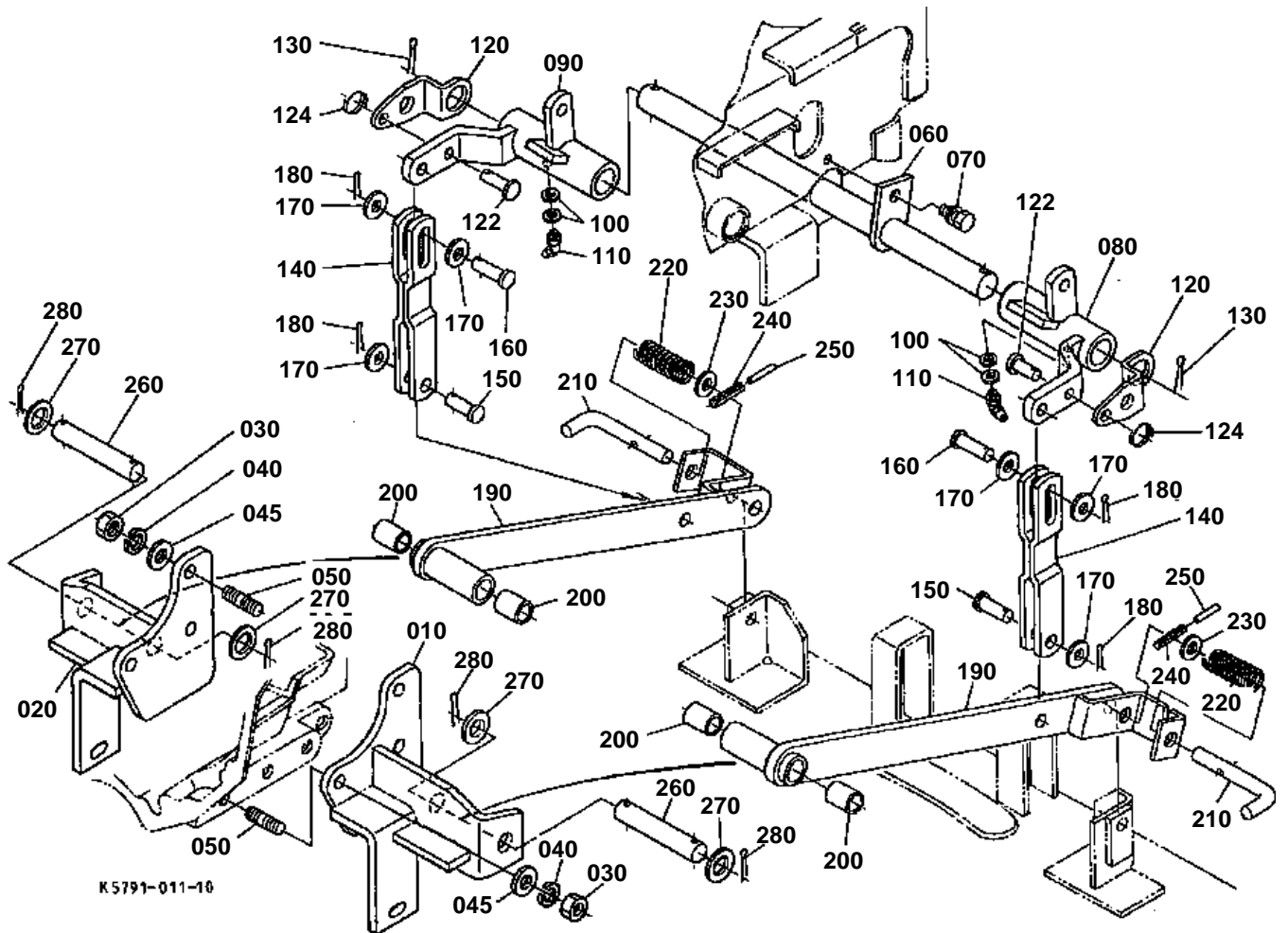

**LIFT LINKAGE**

↔ Interchangeable; ≠ not interchangeable; ← new for old; → old for new

REF.No	Part No.	Description	Q'ty	S.No.	I/C	REMARKS	Weight (kgf)	Weight (lb)
010	K5791-51110	STAY FRONT LH	1				3	6.6
020	K5791-51130	STAY FRONT RH	1				2.93	6.446
030	02174-50120	NUT	6				0.01	0.022
040	04512-60120	WASHER SPRING	6				0.005	0.011
045	32751-14950	WASHER	6				0.011	0.0242
050	01555-51240	STUD	6				0	0
060	K5791-51100	SHAFT LIFT	1				2.37	5.214
070	01123-50825	BOLT	1				0.013	0.0286
080	K5791-51190	ARM LIFT LH	1				0.98	2.156
090	K5791-51210	ARM LIFT RH	1				0.98	2.156
100	66616-34390	SHIM ADJUSTING	4				0.001	0.0022
110	67111-44250	NIPPLE GREASE	2				0.005	0.011
120	K5761-51300	STOPPER	2				0.077	0.1694
122	05122-50825	PIN JOINT	2				0.011	0.0242
124	70712-42190	RING SNAP	2				0.002	0.0044
130	05511-50540	PIN SPLIT	2				0.009	0.0198
140	K5791-51250	LINK LIFT	2				0.55	1.21
150	05122-51235	PIN JOINT	2				0.034	0.0748
160	05122-51240	PIN JOINT	2				0.039	0.0858
170	04013-60120	WASHER PLAIN	6				0.01	0.022
180	05511-50425	PIN SPLIT	4				0.003	0.0066
190	K5761-51293	LINK REAR	2				2.66	5.852
200	08511-02030	BUSH	4				0.02	0.044
210	76539-44650	PIN HINGE	2				0.19	0.418
220	76539-44670	SPRING HINGE PIN	2				0.01	0.022
230	04011-50140	WASHER PLAIN	2				0.007	0.0154
240	05411-00540	PIN SPRING	2				0.004	0.0088
250	05411-00332	PIN SPRING	2				0.001	0.0022
260	K5761-71132	PIN LOADER	2				0.32	0.704
270	70367-72130	COLLAR	4				0.01	0.022
280	05511-50540	PIN SPLIT	4				0.009	0.0198

LIFT ARM

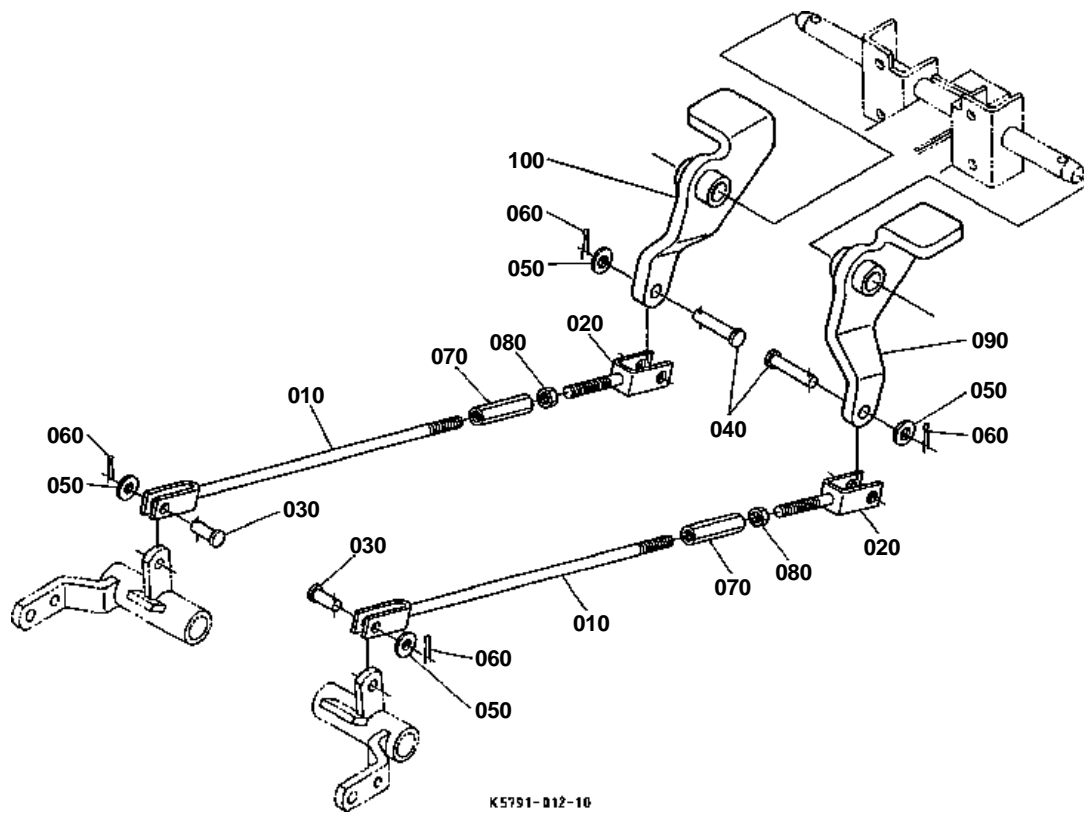

**LIFT ARM**

↔ Interchangeable; ≠ not interchangeable; ← new for old; → old for new

REF.No	Part No.	Description	Q'ty	S.No.	I/C	REMARKS	Weight (kgf)	Weight (lb)
010	K5791-61130	ROD	2				0.45	0.99
020	70723-61150	ROD	2				0.18	0.396
030	05122-51230	PIN JOINT	2				0.029	0.0638
040	05122-61245	PIN JOINT	2				0.04	0.088
050	04013-60120	WASHER PLAIN	4				0.01	0.022
060	05511-50425	PIN SPLIT	4				0.003	0.0066
070	37720-28980	TURNBUCKLE	2				0.099	0.2178
080	02174-50120	NUT	2				0.01	0.022
090	K5761-61160	ARM LIFT LH	1				1.5	3.3
100	K5761-61170	ARM LIFT RH	1				1.5	3.3

LIFT STOPPER

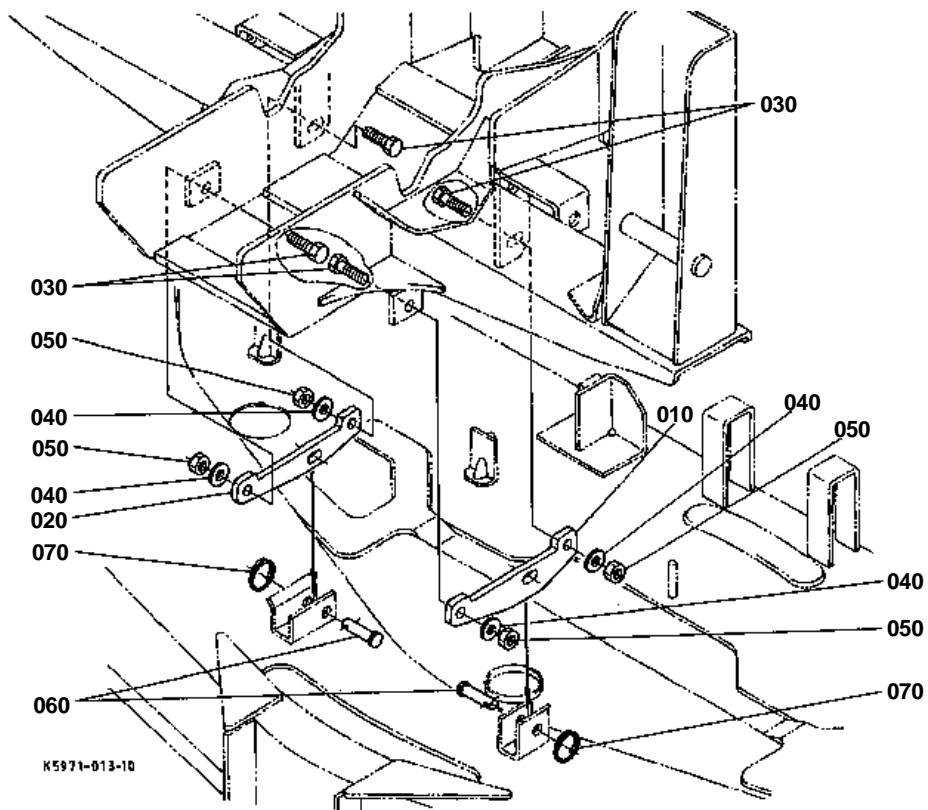



LIFT STOPPER
MOUNTING THE MOWER (RC72-27B) WITH LOADER (LA401)

↔ Interchangeable; ≠ not interchangeable; ← new for old; → old for new

REF.No	Part No.	Description	Q'ty	S.No.	I/C	REMARKS	Weight (kgf)	Weight (lb)
010	K5791-72200	LIFT STOPPER LH	1				0.48	1.056
020	K5791-72300	LIFT STOPPER RH	1				0.37	0.814
030	01133-51235	BOLT	4				0.05	0.11
040	04013-60120	WASHER PLAIN	4				0.01	0.022
050	02174-50120	NUT	4				0.01	0.022
060	05122-61245	PIN JOINT	2			for used 3-point link	0.04	0.088
070	76550-42190	RING SNAP	2			for used 3-point link	0.004	0.0088



↔ Interchangeable; ≠ not interchangeable; ← new for old; → old for new

REF.No	Part No.	Description	Q'ty	S.No.	I/C	REMARKS	Weight (kgf)	Weight (lb)
010	K5791-71110	MANUAL INSTRUCTION	1	<=10921			0.1	0.22
010	K5791-71112	MANUAL INSTRUCTION	1	>=10922	←		0	0