

Instructions for Parts Books

The heading at the top of the page will be the same for the picture of the parts as it is for the page with the part numbers.

Definition of column headings on part number pages:

REF.No → The number referring to the part on the picture page of the parts book.

Part No. → The number assigned to this part at the time of printing the parts book.

Description → Description of part.

Q'ty → Quantity of part used on that page.

S.No. → Serial number range of the equipment that this part will fit.

>= Your serial number should be greater than or equal to the number shown.

<= Your serial number should be lesser than or equal to the serial number shown.

I/C → Interchangeability of part shown.

↔ The part shown will work for the older and later serial number.

The part shown is not interchangeable with the other serial number.

← new for old

→ old for new

Remarks → Notes about this particular part. Sometimes this may say except [FR] or [CA]

Note about Country Codes:

The parts books we use in the United States of America may also contain information about a part that would be different in another country. It is important that you are aware of the country codes in some instances.

Symbol	Country
A	United States of America
CA	Canada
FR	France
GR	Greece
PO	Portugal
AU	Australia

If the remarks column says for example EXCEPT [FR] this part works in all countries except France. That means it will work here in the USA.

ALL PRODUCT INDEX
RCB60-I

GEAR BOX/PULLEY/BLADE

UNIVERSAL JOINT

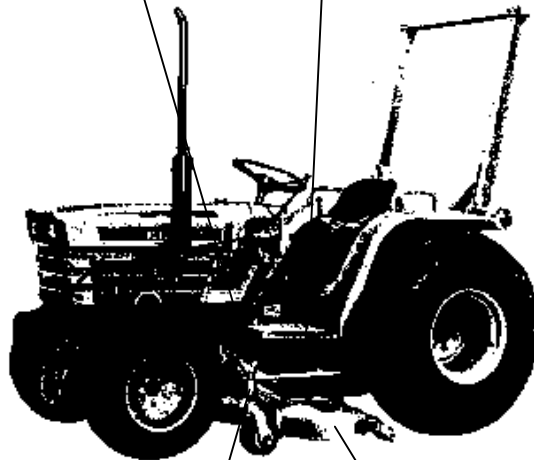

MOWER DECK/WHEEL

LINKAGE/LIFT ARM

Item	Part No.	Description	Book
UNIVERSAL JOINT	01R01	JOINT	100K0059
GEAR BOX/PULLEY/BLADE	01R02	FLANGE	100K0059
	01R0201	FLANGE [FP82-A]	100K0059
	01R03	FRONT PTO	100K0059
	01R0301	FRONT PTO [FP82-A]	100K0059
	01R04	GEAR BOX	100K0059
	01R05	SPINDLE AND BLADE	100K0059
MOWER DECK/WHEEL	01R06	DECK AND FRONT WHEEL	100K0059
	01R07	REAR WHEEL	100K0059
LINKAGE/LIFT ARM	01R08	MAIN STAY	100K0059

JOINT

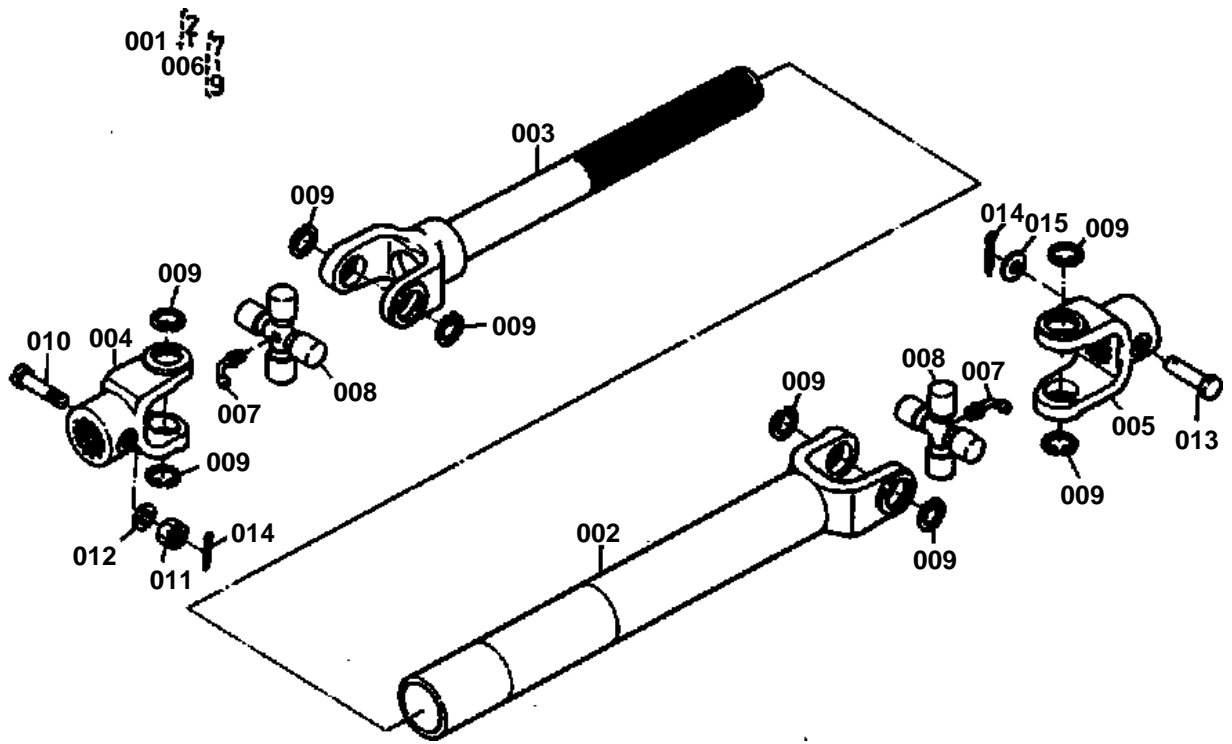



JOINT

↔ Interchangeable; ≠ not interchangeable; ← new for old; → old for new

REF.No	Part No.	Description	Q'ty	S.No.	I/C	REMARKS	Weight (kgf)	Weight (lb)
001	70722-32010	ASSY JOINT, UNIVER.	1			REF.No.002 TO 006	0	0
002	70722-31110	JOINT 1	1				1.73	3.806
003	70722-31120	JOINT 2	1				1.38	3.036
004	70722-31130	JOINT 3	1				0	0
005	70722-31140	JOINT 4	1				0	0
006	70720-32110	ASSY JOINT, CROSS	2			REF.No.007 TO 009	0.2	0.44
007	70720-31212	NIPPLE, GREASE	2				0.006	0.0132
008	70720-31182	JOINT, CROSS	2				0.21	0.462
009	70720-32120	RING, SNAP	8				0.001	0.0022
010	70720-31202	BOLT, FIXED	1				0.02	0.044
011	02356-50080	NUT	1				0.004	0.0088
012	04512-50080	WASHER, SPRING	1				0	0
013	05122-50845	PIN, JOINT	1				0.018	0.0396
014	05511-50218	PIN, SPLIT	2				0.001	0.0022
015	04012-50080	WASHER, SPRING	1				0.001	0.0022

FLANGE

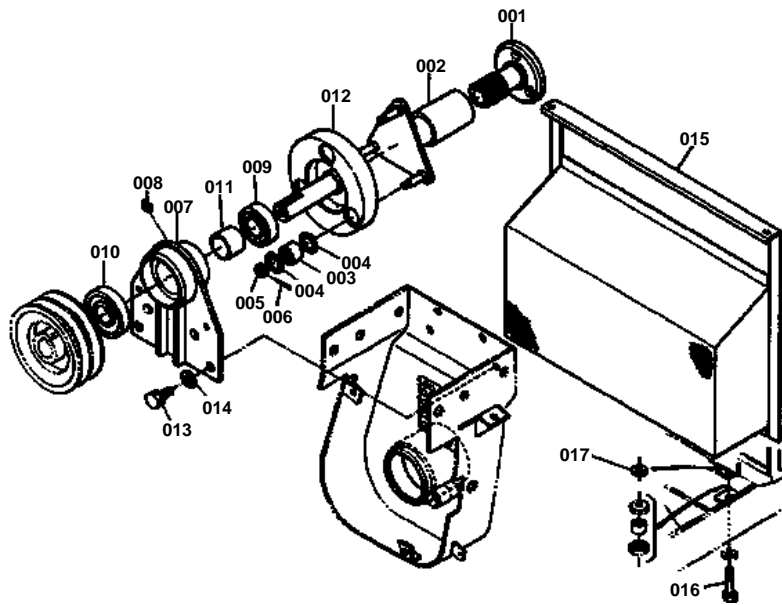



FLANGE
S.No.;<=19999

↔ Interchangeable; ≠ not interchangeable; ← new for old; → old for new

REF.No	Part No.	Description	Q'ty	S.No.	I/C	REMARKS	Weight (kgf)	Weight (lb)
001	70722-32110	FLANGE, PTO	1	<=10250			0.515	1.133
001	70722-32112	FLANGE, PTO	1	>=10251			0.58	1.276
002	70722-32130	SHAFT, COUPLING 1	1	<=10250			1.21	2.662
002	70722-32134	SHAFT, COUPLING 1	1	>=10251			1.15	2.53
003	70722-32150	COUPLING	3				0.031	0.0682
004	04611-00250	CIR-CLIP, INTERNAL	6				0.001	0.0022
005	02312-50080	NUT, SLOTTED	3				0.004	0.0088
006	05511-50220	PIN, SPLIT	3				0.001	0.0022
007	70722-32170	SUPPORT, COUPLING	1	<=10250			0	0
007	70722-32174	SUPPORT, COUPLING	1	>=10001			1.45	3.19
008	06613-10675	NIPPLE, GREASE	1				0.003	0.0066
009	70722-32190	BEARING, BALL	1				0.14	0.308
010	08111-06305	BEARING, BALL	1				0.22	0.484
011	70722-32210	COLLAR 1	1				0.06	0.132
012	70722-32230	SHAFT, COUPLING 2	1				0	0
013	01130-51025	BOLT	4				0	0
014	04013-50100	WASHER, PLAIN	4				0	0
015	67800-86210	NET, DUSTPROOF	1				1.4	3.08
016	66711-51340	BOLT, SET RADIATOR	2				0.032	0.0704
017	04013-50100	WASHER, PLAIN	2				0	0

FLANGE [FP82-A]

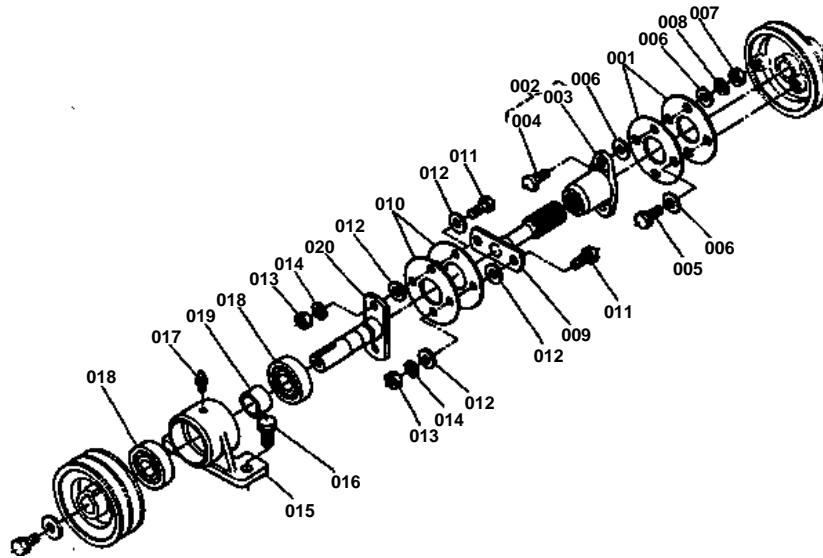



FLANGE [FP82-A]
S.No.;>=20001

↔ Interchangeable; ≠ not interchangeable; ← new for old; → old for new

REF.No	Part No.	Description	Q'ty	S.No.	I/C	REMARKS	Weight (kgf)	Weight (lb)
001	76521-31510	PLATE, COUPLING	2				0.02	0.044
002	76521-31530	ASSY SHAFT, COUPLING	1			REF.No.003, 004	0.35	0.77
003	76521-31550	SHAFT, COUPLING 1	1				0.35	0.77
004	76521-31570	BOLT	2				0.02	0.044
005	01133-51022	BOLT	2				0.025	0.055
006	04013-50100	WASHER, PLAIN	6				0	0
007	02118-50100	NUT	2				0.005	0.011
008	04512-50100	WASHER, SPRING	2				0	0
009	76521-32130	SHAFT, COUPLING	1				0.55	1.21
010	76521-31510	PLATE, COUPLING	2				0.02	0.044
011	01173-51025	BOLT	4				0.021	0.0462
012	04013-50100	WASHER, PLAIN	8				0	0
013	02118-50100	NUT	4				0.005	0.011
014	04512-50100	WASHER, SPRING	4				0	0
015	76521-32170	SUPPORT, COUPLING	1				1.3	2.86
016	01133-51228	BOLT	2				0.04	0.088
017	06613-10675	NIPPLE, GREASE	1				0.003	0.0066
018	08111-06305	BEARING, BALL	2				0.22	0.484
019	76521-32210	COLLAR 1	1				0.055	0.121
020	76521-32230	SHAFT, COUPLING	1				0.55	1.21

FRONT PTO

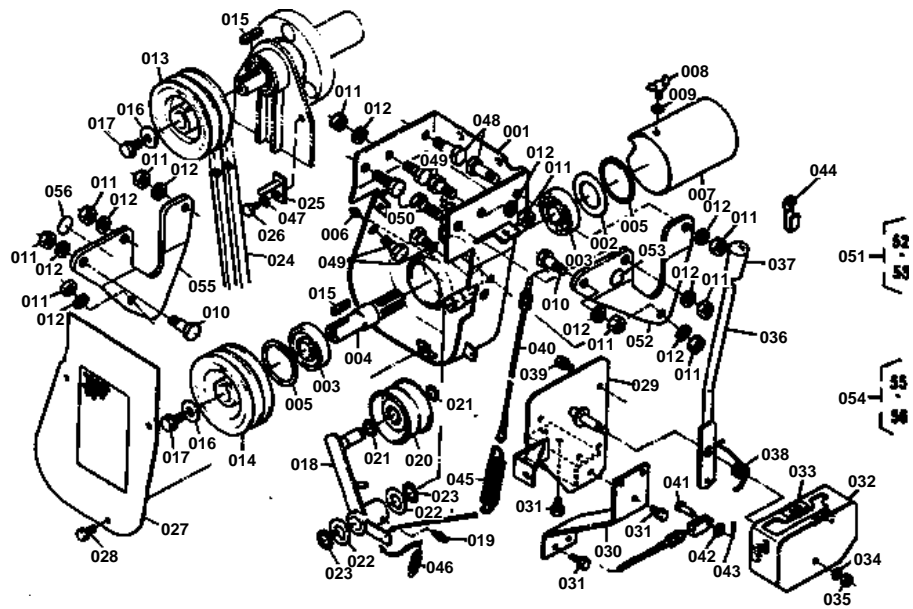



FRONT PTO
S.No.;<=19999

↔ Interchangeable; ≠ not interchangeable; ← new for old; → old for new

REF.No	Part No.	Description	Q'ty	S.No.	I/C	REMARKS	Weight (kgf)	Weight (lb)
001	70722-32313	CASE, FRONT PTO	1				6.6	14.52
002	70722-32320	PLATE, SEAL	1				0.015	0.033
003	08131-06305	BEARING, BALL	2				0.24	0.528
004	70722-32330	SHAFT, JOINT	1				0.5	1.1
005	04611-00620	CIR-CLIP, INTERNAL	2				0.011	0.0242
006	06613-10010	NIPPLE, GREASE	1				0.006	0.0132
007	70722-32350	COVER, JOINT	1				0.66	1.452
008	01811-50812	BOLT, WING	1				0.03	0.066
009	04512-50080	WASHER, SPRING	1				0	0
010	70722-32400	BOLT, REAMER C	2				0.042	0.0924
011	02174-50120	NUT	10				0.01	0.022
012	04512-50120	WASHER, SPRING	10				0	0
013	70722-32370	PULLEY 117	1				1.41	3.102
014	70722-32390	PULLEY 119	1				1.5	3.3
015	05712-00732	KEY, FEATHER	2				0.013	0.0286
016	04015-50100	WASHER, PLAIN	2				0.016	0.0352
017	01133-51016	BOLT	2				0.015	0.033
018	70722-32410	ARM, FRONT TENSION	1				0.43	0.946
019	06613-10675	NIPPLE, GREASE	1				0.003	0.0066
020	54201-13500	ASSY PULLEY, TENSION	1				0.35	0.77
021	04612-00170	CIR-CLIP, EXTERNAL	2				0.001	0.0022
022	04014-50180	WASHER, PLAIN	2				0.011	0.0242
023	04612-00200	CIR-CLIP, EXTERNAL	2				0.001	0.0022
024	70722-32430	BELT 40	2				0.175	0.385
025	70722-32452	RETAINER, BELT	3	<=10250			0.05	0.11
025	70722-32452	RETAINER, BELT	2	>=10251			0.05	0.11
026	01053-50820	BOLT	3	<=10250			0.012	0.0264
026	01053-50820	BOLT	2	>=10251			0.012	0.0264
027	70722-32490	COVER, FRONT PTO	1				0.55	1.21
028	01123-50816	BOLT	3				0.011	0.0242
029	70722-32510	HOLDER, LEVER	1				1.43	3.146
030	70722-32530	STAY, LEVER HOLDER	1				0.6	1.32
031	01123-50820	BOLT	8				0.011	0.0242
032	70722-32550	PLATE, GUIDE	1				0.65	1.43
033	70722-32570	LABEL	1				0.001	0.0022
034	04512-50080	WASHER, SPRING	1				0	0
035	02114-50080	NUT	1				0.005	0.011
036	70722-32610	LEVER	1				0	0
037	06914-00140	GRIP, LEVER	1				0.014	0.0308
038	70722-32630	SPRING, LEVER	1				0.014	0.0308
039	01123-50816	BOLT	2				0.011	0.0242
040	70722-32650	WIRE, MAIN CLUTCH	1				0.264	0.5808
041	05122-50818	PIN, JOINT	1				0.008	0.0176
042	04013-50080	WASHER, PLAIN	1				0	0
043	05511-50218	PIN, SPLIT	1				0.001	0.0022
044	32240-34490	CLAMP, CORD 2	1				0.003	0.0066
045	70722-32673	SPRING, CLUTCH 1	1				0.01	0.022
046	70722-32690	SPRING, CLUTCH 2	1				0.01	0.022
047	04512-50080	WASHER, SPRING	3	<=10250			0	0
047	04512-50080	WASHER, SPRING	2	>=10251			0	0
048	70722-32300	BOLT, REAMER F	2				0.04	0.088
049	70725-32380	BOLT, REAMER A	4				0.04	0.088
050	70722-32380	BOLT, REAMER B	2				0.047	0.1034
051	70722-32260	ASSY STAY, PTO C. LH	1			REF.No.052, 053	1.35	2.97
052	99999-99999	BLANK	0			ORDER BY REF.No.051	0	0
053	34152-57790	MARK, L	1				0.001	0.0022



FRONT PTO
S.No.;<=19999

↔ Interchangeable; ≠ not interchangeable; ← new for old; → old for new

REF.No	Part No.	Description	Q'ty	S.No.	I/C	REMARKS	Weight (kgf)	Weight (lb)
054	70722-32280	ASSY STAY, PTO C.RH	1			REF.No.055, 056	1.25	2.75
055	99999-99999	BLANK	0			ORDER BY REF.No.054	0	0
056	34152-57710	MARK, R	1				0.001	0.0022

FRONT PTO [FP82-A]

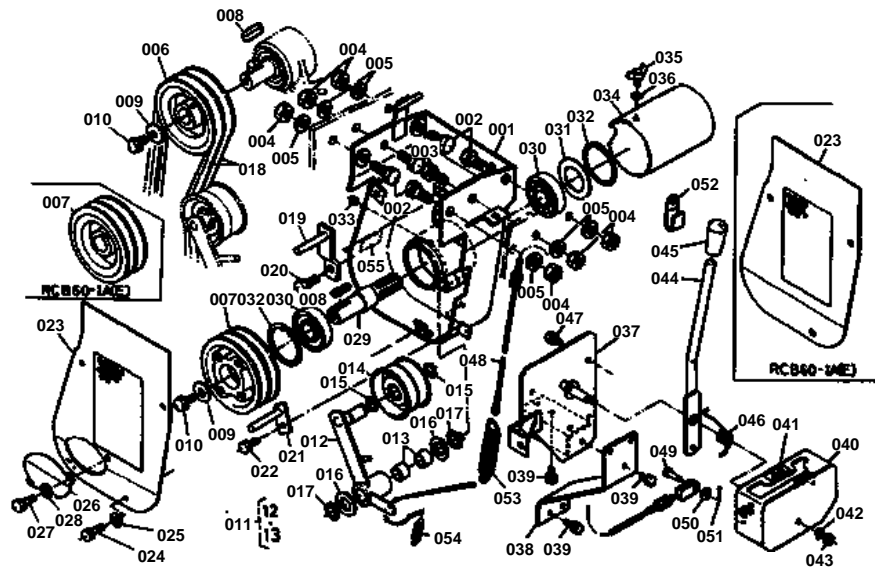



FRONT PTO [FP82-A]
S.No.;>=20001

↔ Interchangeable; ≠ not interchangeable; ← new for old; → old for new

REF.No	Part No.	Description	Q'ty	S.No.	I/C	REMARKS	Weight (kgf)	Weight (lb)
001	76562-32310	CASE, FRONT PTO	1				6.6	14.52
002	76560-32320	BOLT, REAMER G	4				0.04	0.088
003	01173-51228	BOLT	2				0.036	0.0792
004	02174-50120	NUT	6				0.01	0.022
005	04512-50120	WASHER, SPRING	6				0	0
006	70722-32370	PULLEY 117	1				1.41	3.102
007	76560-32390	PULLEY, PTO	1				2	4.4
008	05712-00732	KEY, FEATHER	2				0.013	0.0286
009	04015-50100	WASHER, PLAIN	2				0.016	0.0352
010	01133-51018	BOLT	2				0.02	0.044
011	76560-32420	ASSY ARM, F. TENSION	1			REF.No.012, 013	0.4	0.88
012	76521-32410	ARM, FRONT TENSION	1				0.4	0.88
013	70706-32320	BUSH	2				0	0
014	54201-13500	ASSY PULLEY, TENSION	1				0.35	0.77
015	04612-00170	CIR-CLIP, EXTERNAL	2				0.001	0.0022
016	04014-50180	WASHER, PLAIN	2				0.011	0.0242
017	04612-00200	CIR-CLIP, EXTERNAL	2				0.001	0.0022
018	70722-32430	BELT 40	2				0.175	0.385
019	76562-32450	RETAINER, BELT 1	1				0.93	2.046
020	01133-51020	BOLT	1				0.02	0.044
021	70722-32452	RETAINER, BELT	1				0.05	0.11
022	01123-50820	BOLT	1				0.011	0.0242
023	76562-32490	COVER 1	1				0.51	1.122
024	01123-50816	BOLT	3				0.011	0.0242
025	04012-50080	WASHER, PLAIN	1				0.001	0.0022
026	76560-32500	COVER 2	1				0.1	0.22
027	01123-50816	BOLT	2				0.011	0.0242
028	04012-50080	WASHER, PLAIN	2				0.001	0.0022
029	70722-32330	SHAFT, JOINT	1				0.5	1.1
030	76560-32300	BEARING, BALL	2				0.226	0.4972
031	70722-32320	PLATE, SEAL	1				0.015	0.033
032	04611-00620	CIR-CLIP, INTERNAL	2				0.011	0.0242
033	06613-10010	NIPPLE, GREASE	1				0.006	0.0132
034	70722-32350	COVER, JOINT	1				0.66	1.452
035	01811-50812	BOLT, WING	1				0.03	0.066
036	04512-50080	WASHER, SPRING	1				0	0
037	70722-32510	HOLDER, LEVER	1				1.43	3.146
038	70722-32530	STAY, LEVER HOLDER	1				0.6	1.32
039	01123-50820	BOLT	8				0.011	0.0242
040	70722-32550	PLATE, GUIDE	1				0.65	1.43
041	70722-32570	LABEL	1				0.001	0.0022
042	04512-50080	WASHER, SPRING	1				0	0
043	02114-50080	NUT	1				0.005	0.011
044	70722-32610	LEVER	1				0	0
045	06914-00140	GRIP, LEVER	1				0.014	0.0308
046	70722-32630	SPRING, LEVER	1				0.014	0.0308
047	01123-50816	BOLT	2				0.011	0.0242
048	70722-32650	WIRE, MAIN CLUTCH	1				0.264	0.5808
049	05122-50818	PIN, JOINT	1				0.008	0.0176
050	04013-50080	WASHER, PLAIN	1				0	0
051	05511-50218	PIN, SPLIT	1				0.001	0.0022
052	32240-34490	CLAMP, CORD 2	1				0.003	0.0066
053	70722-32673	SPRING, CLUTCH 1	1				0.01	0.022
054	70722-32690	SPRING, CLUTCH 2	1				0.01	0.022
055	76562-41170	LABEL	1				0	0

GEAR BOX

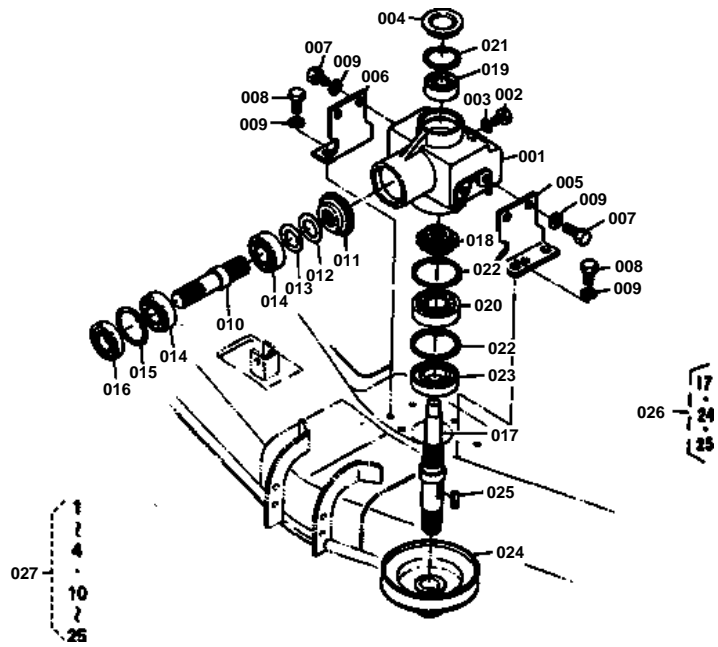



GEAR BOX

↔ Interchangeable; ≠ not interchangeable; ← new for old; → old for new

REF.No	Part No.	Description	Q'ty	S.No.	I/C	REMARKS	Weight (kgf)	Weight (lb)
001	70722-33110	CASE, BEVEL	1				3.5	7.7
002	01173-51014	BOLT	2				0.015	0.033
003	04717-01000	WASHER	2				0.001	0.0022
004	55314-22430	CAP, ROLLER	1				0.039	0.0858
005	70722-33130	STAY, BEVEL CASE LH	1				0	0
006	70722-33150	STAY, BEVEL CASE RH	1				0	0
007	01173-51222	BOLT	4				0.031	0.0682
008	01170-51230	BOLT	4				0	0
009	04512-50120	WASHER, SPRING	8				0	0
010	70722-33310	SHAFT, PINION	1				0.46	1.012
011	70722-33330	GEAR, BEVEL 17	1				0.25	0.55
012	70720-33350	SHIM 1	1				0.001	0.0022
013	70720-33360	SHIM 2	1				0.001	0.0022
014	08101-06205	BEARING, BALL	2				0.14	0.308
015	04611-00520	CIR-CLIP, INTERNAL	1				0.009	0.0198
016	09502-55210	SEAL, OIL	1				0.025	0.055
017	99999-99999	BLANK	0			ORDER BY REF.No.026	0	0
018	70722-33530	GEAR, BEVEL 15	1				0.18	0.396
019	08101-06303	BEARING, BALL	1				0.112	0.2464
020	08101-06305	BEARING, BALL	1				0.23	0.506
021	04611-00470	CIR-CLIP, INTERNAL	1				0.006	0.0132
022	04611-00620	CIR-CLIP, INTERNAL	2				0.011	0.0242
023	67121-56660	SEAL, OIL	1				0.027	0.0594
024	99999-99999	BLANK	0			ORDER BY REF.No.026	0	0
025	05712-00728	KEY, FEATHER	1				0.01	0.022
026	70722-99040	ASSY PULLEY, CENTER	1			REF.No.017,024 AND 025 ≤SEPT.1989	1.53	3.366
026	70712-99750	ASSY PULLEY, CENTER	1		←	REF.No.017,024 AND 025 ≥OCT.1989	0.7	1.54
027	70722-99510	ASSY CASE,BEVEL GEAR	1				6.4	14.08

SPINDLE AND BLADE

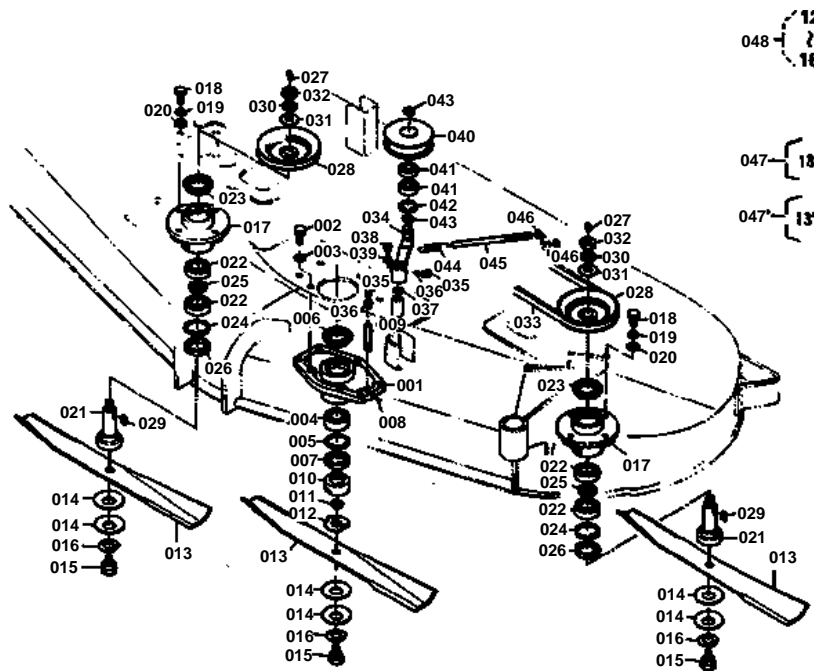



SPINDLE AND BLADE

↔ Interchangeable; ≠ not interchangeable; ← new for old; → old for new

REF.No	Part No.	Description	Q'ty	S.No.	I/C	REMARKS	Weight (kgf)	Weight (lb)
001	70722-34110	HOLDER, PULLEY 1	1				2.6	5.72
002	01173-51225	BOLT	3				0.033	0.0726
003	04512-50120	WASHER, SPRING	3				0	0
004	08241-05205	BEARING, BALL	1				0.177	0.3894
005	04611-00520	CIR-CLIP, INTERNAL	1				0.009	0.0198
006	70722-34120	SEAL, OIL	1				0.025	0.055
007	09500-35528	SEAL, OIL	1				0.017	0.0374
008	03410-50606	SCREW, SET	1				0.001	0.0022
009	70722-34130	PIPE, EXTENSION	1				0	0
010	70722-34150	BOSS, CUTTER	1				0.352	0.7744
011	04612-00220	CIR-CLIP, EXTERNAL	1				0.001	0.0022
012	70722-34320	PLATE	1				0.02	0.044
013	70722-34330	BLADE	3				0.99	2.178
013	70722-99020	BLADE, LOW SUCTION	3			SERVICE PARTS	0.95	2.09
014	70722-34350	RETAINER, CUTTER	6				0.055	0.121
015	70722-34370	BOLT	3			≤OCT.1986	0	0
015	70722-34374	BOLT	3		←	≥NOV.1986	0.1	0.22
016	70722-34390	WASHER	3				0.009	0.0198
017	70722-34510	HOLDER, PULLEY 2	2				1.91	4.202
018	01170-51228	BOLT	8				0	0
019	04512-50120	WASHER, SPRING	8				0	0
020	04013-50120	WASHER, PLAIN	8				0	0
021	70722-34530	SHAFT, CUTTER	2				0.52	1.144
022	08101-06205	BEARING, BALL	4				0.14	0.308
023	70722-34120	SEAL, OIL	2				0.025	0.055
024	04611-00520	CIR-CLIP, INTERNAL	2				0.009	0.0198
025	70721-34550	COLLAR 2	2				0.029	0.0638
026	09500-35528	SEAL, OIL	2				0.017	0.0374
027	06613-10675	NIPPLE, GREASE	2				0.003	0.0066
028	70721-33550	PULLEY	2			≤MAR.1985	0	0
028	70725-33570	PULLEY	2		←	≥APR.1985	0	0
028	70712-99780	PULLEY	2	≥21010	←	I	0.6	1.32
029	05712-00722	KEY, FEATHER	2				0.009	0.0198
030	04512-50160	WASHER, SPRING	2				0	0
031	70721-34560	WASHER, PLAIN	2				0.01	0.022
032	02172-50160	NUT	2				0.017	0.0374
033	70722-34710	BELT 110	1				0.47	1.034
034	70722-34730	ARM, TENSION	1				0.39	0.858
035	66616-34360	NIPPLE, GREASE	2				0	0
036	66616-34390	SHIM, ADJUSTING	2				0.001	0.0022
037	04811-06170	O RING	1				0.001	0.0022
038	01123-50814	BOLT	1				0	0
039	04015-50080	WASHER, PLAIN	1				0	0
040	70720-69210	PULLEY, TENSION 2	1	≤10603			0	0
040	70720-69212	PULLEY, TENSION 2	1	≥10001			0.97	2.134
041	08141-06203	BEARING, BALL	2				0.064	0.1408
042	04611-00400	CIR-CLIP, INTERNAL	1				0.005	0.011



SPINDLE AND BLADE

↔ Interchangeable; ≠ not interchangeable; ← new for old; → old for new

REF.No	Part No.	Description	Q'ty	S.No.	I/C	REMARKS	Weight (kgf)	Weight (lb)
043	04612-00170	CIR-CLIP, EXTERNAL	2				0.001	0.0022
044	70720-34750	SPRING, TENSION	1	<=10250			0.09	0.198
044	70722-34750	SPRING, TENSION	1	>=10251			0.15	0.33
045	70720-34770	BOLT, TENSION	1	<=10250			0.1	0.22
045	70722-34770	BOLT, TENSION	1	>=10251			0	0
046	02118-50100	NUT	2				0.005	0.011
047	70722-99010	KIT BLADE	1			REF.No.013	0	0
047	70722-99030	KIT BLADE, LOW SUC.	1			REF.No.013	0	0
048	70722-99650	KIT BLADE	1			REF.No.012 TO 016 SERVICE PARTS	3.5	7.7

DECK AND FRONT WHEEL

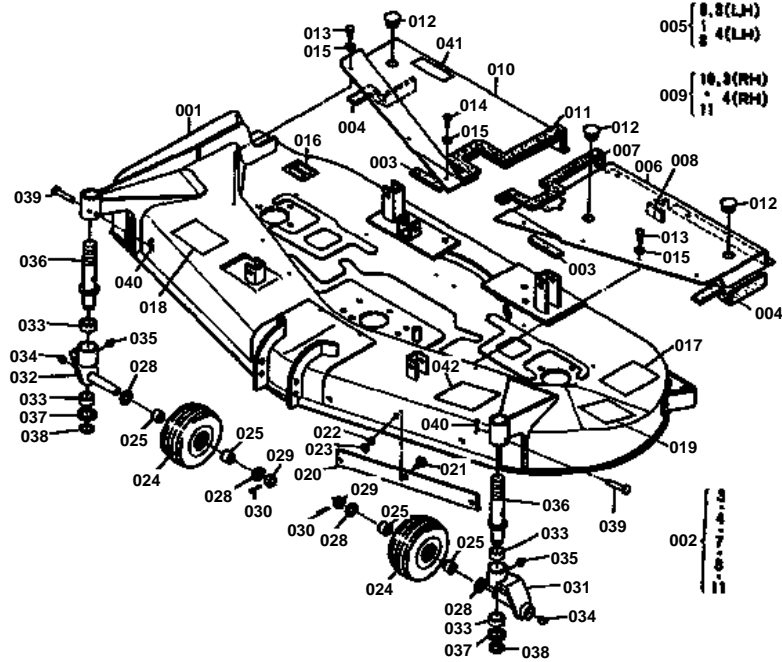

26 09220-20284
27 04611-00280

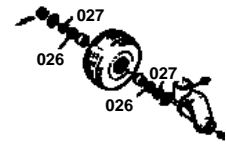



DECK AND FRONT WHEEL

↔ Interchangeable; ≠ not interchangeable; ← new for old; → old for new

REF.No	Part No.	Description	Q'ty	S.No.	I/C	REMARKS	Weight (kgf)	Weight (lb)
001	70722-41160	DECK, MOWER	1	<=21015		RCB60-I	74	162.8
001	70722-21160	DECK, MOWER	1	>=21016	≠	RCB60-I	56	123.2
002	70722-99000	KIT, SEAL	1			REF.No.003, 004, 007, 008 AND 011	0.03	0.066
003	70722-41210	SEAL 1	2				0.001	0.0022
004	70722-41220	SEAL 2	2				0.001	0.0022
005	70722-41130	ASSY COVER, LH	1	<=21015		RCB60-I REF.No.006 TO 008, 003(LH) AND 0	2	4.4
005	70722-21130	ASSY COVER, LH	1	>=21016	≠	RCB60-I REF.No.006 TO 008, 003(LH) AND 0	0	0
006	99999-99999	BLANK	0			ORDER BY REF.No.005	0	0
007	70722-41240	SEAL 4	1				0.006	0.0132
008	70722-41260	SEAL 6	1				0.02	0.044
009	70722-41150	ASSY COVER, RH	1	<=21015		RCB60-I REF.No.010, 011, 003(RH) AND 004(2	4.4
009	70722-21150	ASSY COVER, RH	1	>=21016	≠	RCB60-I REF.No.010, 011, 003(RH) AND 004(0	0
010	99999-99999	BLANK	0			ORDER BY REF.No.009	0	0
011	70722-41280	SEAL 8	1				0.006	0.0132
012	66204-51160	CAP, BEARING	3				0.007	0.0154
013	01123-50814	BOLT	12				0	0
014	01123-50818	BOLT	2				0.012	0.0264
015	04013-50080	WASHER, PLAIN	14				0	0
016	70722-41170	LABEL	1			RCB60-I	0	0
017	70720-47153	LABEL 1	1				0	0
018	70720-41140	LABEL 2	1				0	0
019	70721-41180	LABEL	1				0.003	0.0066
020	70722-41190	PLATE, FRONT	1				0	0
021	01173-51018	BOLT	3				0.018	0.0396
022	04512-50100	WASHER, SPRING	3				0	0
023	02118-50100	NUT	3				0.005	0.011
024	70722-42110	WHEEL, FRONT	2				1.9	4.18
025	70722-44190	BUSH 2	4				0.041	0.0902
026	09220-20284	SEAL, OIL	4				0.004	0.0088
027	04611-00280	CIR-CLIP, INTERNAL	4			<=1990.APRIL	0.002	0.0044
028	04013-50200	WASHER, PLAIN	4			<=1990.APRIL	0.02	0.044
029	70722-42140	COLLAR	2				0.035	0.077
030	05511-50540	PIN, SPLIT	2				0.009	0.0198
031	70722-42150	STAY, FRONT WHEEL LH	1				0	0
032	70722-42170	STAY, FRONT WHEEL RH	1				0	0
033	70722-42190	BUSH 1	4				0.045	0.099
034	06613-10010	NIPPLE, GREASE	2				0.006	0.0132
035	06613-10675	NIPPLE, GREASE	2				0.003	0.0066
036	70722-43110	SHAFT, FRONT WHEEL	2				1.15	2.53
037	70722-43130	COLLAR, FRONT WHEEL	2				0.015	0.033
038	04612-00300	CIR-CLIP, EXTERNAL	2				0.003	0.0066
039	05122-51050	PIN, JOINT	2				0.032	0.0704
040	70712-42190	PIN, SNAP	2				0.002	0.0044
041	36200-98160	MARK, FRONT	1				0.002	0.0044
042	70725-34570	LABEL, BLADE	1	>=10251			0.004	0.0088

REAR WHEEL

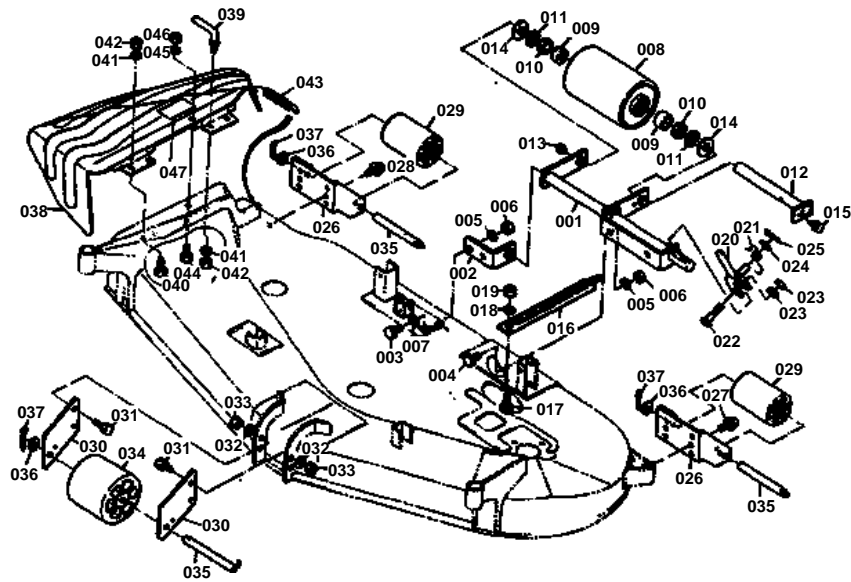



REAR WHEEL

↔ Interchangeable; ≠ not interchangeable; ← new for old; → old for new

REF.No	Part No.	Description	Q'ty	S.No.	I/C	REMARKS	Weight (kgf)	Weight (lb)
001	70722-44110	ARM, REAR WHEEL	1				0	0
002	70722-44130	BRACKET, REAR WHEEL	1				0	0
003	01173-51022	BOLT	2				0.019	0.0418
004	01173-51028	BOLT	2				0.022	0.0484
005	04512-50100	WASHER, SPRING	4				0	0
006	02118-50100	NUT	4				0.005	0.011
007	04015-50100	WASHER, PLAIN	2				0.016	0.0352
008	70722-44150	WHEEL, REAR	1	<=21015		RCB60-I	0	0
008	76543-46160	WHEEL, REAR	1	>=21016	↔	RCB60-I	2.1	4.62
009	70722-44190	BUSH 2	2				0.041	0.0902
010	09220-20284	SEAL, OIL	2				0.004	0.0088
011	04611-00280	CIR-CLIP, INTERNAL	2				0.002	0.0044
012	70722-44170	SHAFT, REAR WHEEL	1				0	0
013	06613-10010	NIPPLE, GREASE	1				0.006	0.0132
014	04013-50200	WASHER, PLAIN	2				0.02	0.044
015	01123-50814	BOLT	1				0	0
016	70722-45110	GUIDE, REAR WHEEL	1				0	0
017	01173-51025	BOLT	2				0.021	0.0462
018	04512-50100	WASHER, SPRING	2				0	0
019	02118-50100	NUT	2				0.005	0.011
020	70722-45170	LEVER, REAR WHEEL	1				0.22	0.484
021	70721-45190	SPRING, LEVER	1				0.02	0.044
022	01153-50840	BOLT	1				0.018	0.0396
023	02114-50080	NUT	2				0.005	0.011
024	04012-50080	WASHER, PLAIN	1				0.001	0.0022
025	05511-50215	PIN, SPLIT	1				0.001	0.0022
026	70722-46110	STAY, ROLLER	2				0	0
027	01133-51025	BOLT	2				0.023	0.0506
028	01133-51020	BOLT	2				0.02	0.044
029	70721-46170	WHEEL	2	>=10001			0	0
029	70713-46170	WHEEL	2	>=10001			0	0
030	70722-46130	STAY, FRONT ROLLER	2				0	0
031	01173-51028	BOLT	4				0.022	0.0484
032	04512-50100	WASHER, SPRING	4				0	0
033	02118-50100	NUT	4				0.005	0.011
034	70722-46150	ROLLER, FRONT	1				0	0
035	70720-46183	PIN, GAUGE WHEEL	3				0.125	0.275
036	04011-50120	WASHER, PLAIN	3				0.005	0.011
037	05511-50425	PIN, SPLIT	3				0.003	0.0066
038	70722-47110	COVER	1	<=21015		RCB60-I	3.85	8.47
038	70722-27110	COVER	1	>=21016	≠	RCB60-I	3.7	8.14
039	70721-47130	STOPPER, CHUTE	1				0.05	0.11
040	01173-51020	BOLT	3				0.017	0.0374
041	04512-50100	WASHER, SPRING	4				0	0
042	02118-50100	NUT	4				0.005	0.011
043	70722-47120	SPRING	1				0.06	0.132
044	01173-51025	BOLT	1				0.021	0.0462
045	04512-50100	WASHER, SPRING	1				0	0
046	02118-50100	NUT	1				0.005	0.011
047	70720-47140	LABEL 3	1				0	0

MAIN STAY

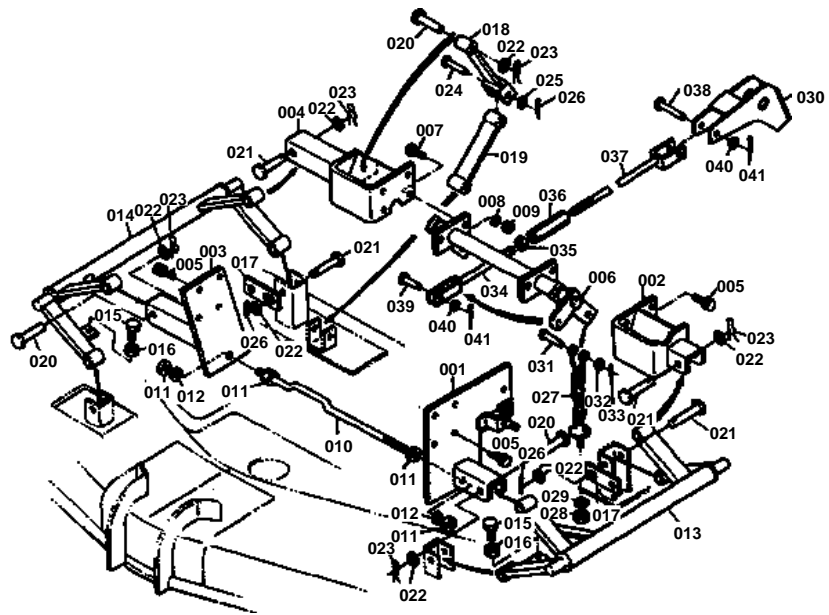



MAIN STAY

↔ Interchangeable; ≠ not interchangeable; ← new for old; → old for new

REF.No	Part No.	Description	Q'ty	S.No.	I/C	REMARKS	Weight (kgf)	Weight (lb)
001	70722-51110	STAY, LH FRONT	1				4.2	9.24
002	70722-51130	STAY, LH REAR	1				1.88	4.136
003	70722-51150	STAY, RH FRONT	1				2.57	5.654
004	70722-51170	STAY, RH REAR	1				2.5	5.5
005	01133-51028	BOLT	12				0.027	0.0594
006	70722-51180	HOLDER, LIFT LINK	1				2.75	6.05
007	01173-51028	BOLT	4				0.022	0.0484
008	04512-50100	WASHER, SPRING	4				0	0
009	02118-50100	NUT	4				0.005	0.011
010	70722-51200	GUIDE, FRONT	1				0.4	0.88
011	02174-50140	NUT	4				0.014	0.0308
012	04512-50140	WASHER, SPRING	2				0	0
013	70722-51160	STAY, LH	1				5.12	11.264
014	70722-51190	STAY, RH	1				5.1	11.22
015	01175-51238	BOLT	2				0.05	0.11
016	02174-50120	NUT	2				0.01	0.022
017	70722-51222	HOLDER	2				0.165	0.363
018	70720-51270	LINK 1	1				0.41	0.902
019	70722-51290	LINK 2	1				0	0
020	05122-51460	PIN, JOINT	5				0.074	0.1628
021	05122-51480	PIN, JOINT	4				0.09	0.198
022	04011-50140	WASHER, PLAIN	9				0.007	0.0154
023	70712-51140	PIN, SNAP	5				0.009	0.0198
024	05122-51260	PIN, JOINT	2				0.055	0.121
025	04011-50120	WASHER, PLAIN	2				0.005	0.011
026	05511-50425	PIN, SPLIT	6				0.003	0.0066
027	70732-61110	ASSY CHAIN	2				0.325	0.715
028	02174-50120	NUT	2				0.01	0.022
029	04512-50120	WASHER, SPRING	2				0	0
030	70722-61170	ARM, LIFT	1				1	2.2
030	76521-61170	ARM, LIFT LH	1			SERVICE PARTS	0	0
031	05122-51035	PIN, JOINT	2				0.023	0.0506
032	04011-50100	WASHER, PLAIN	2				0.002	0.0044
033	70712-42190	PIN, SPLIT	2				0.002	0.0044
034	70722-61130	ROD 1	1				0.23	0.506
035	02174-50120	NUT	1				0.01	0.022
036	37720-28980	TURNBUCKLE	1				0.099	0.2178
037	70722-61150	ROD 2	1				0.45	0.99
038	05122-51260	PIN, JOINT	1				0.055	0.121
039	05122-51230	PIN, JOINT	1				0.029	0.0638
040	04011-50120	WASHER, PLAIN	2				0.005	0.011
041	05511-50420	PIN, SPLIT	2				0.002	0.0044
042	70722-11400	MANUAL, INSTRUCTION	1			NOT SHOWN IN FIG.	0	0