

Instructions for Parts Books

The heading at the top of the page will be the same for the picture of the parts as it is for the page with the part numbers.

Definition of column headings on part number pages:

REF.No → The number referring to the part on the picture page of the parts book.

Part No. → The number assigned to this part at the time of printing the parts book.

Description → Description of part.

Q'ty → Quantity of part used on that page.

S.No. → Serial number range of the equipment that this part will fit.

>= Your serial number should be greater than or equal to the number shown.

<= Your serial number should be lesser than or equal to the serial number shown.

I/C → Interchangeability of part shown.

↔ The part shown will work for the older and later serial number.

The part shown is not interchangeable with the other serial number.

← new for old

→ old for new

Remarks → Notes about this particular part. Sometimes this may say except [FR] or [CA]

Note about Country Codes:

The parts books we use in the United States of America may also contain information about a part that would be different in another country. It is important that you are aware of the country codes in some instances.

Symbol	Country
A	United States of America
CA	Canada
FR	France
GR	Greece
PO	Portugal
AU	Australia

If the remarks column says for example EXCEPT [FR] this part works in all countries except France. That means it will work here in the USA.

Kubota RCK60-24B Mower

Part No.		Book
01M01	UNIVERSAL JOINT	100A0092
01M02	BEVEL GEAR CASE	100A0092
01M03	PULLEY HOLDER	100A0092
01M04	BLADE	100A0092
01M05	TENSION PULLEY	100A0092
01M0603	MOWER DECK	100A0092
01M07	FRONT GAUGE WHEEL	100A0092
01M08	LINKAGE	100A0092
01M0902	REAR WHEEL	100A0092
01M10	DISCHARGE COVER	100A0092
01M11	LIFT LINKAGE	100A0092
01M12	LIFT ARM	100A0092
01M13	ACCESSORIES AND SERVICE PARTS	100A0092



UNIVERSAL JOINT

↔ Interchangeable; ≠ not interchangeable; ← new for old; → old for new

REF.No	Part No.	Description	Q'ty	S.No.	I/C	REMARKS	Weight (kgf)	Weight (lb)
010	K5763-32030	UNIVERSAL JOINT	1				0	0
015	K5763-73120	LABEL ROTATION	1				0	0
020	K5763-31150	YOKE QUICK	1				0	0
030	K5651-31130	YOKE PTO	1				0	0
040	K5763-31140	YOKE SHAFT	1				0	0
050	K5651-31170	YOKE SLEEVE	1				0	0
060	K5651-31160	NIPPLE GREASE	1				0	0
070	K5651-31180	ASSY.JOINT CROSS	2				0	0
080	K5651-32120	RING SNAP	8				0	0
090	K5651-31210	NIPPLE GREASE	2				0.011	0.0242
100	01153-51035	BOLT	1				0.025	0.055
110	04512-50100	WASHER SPRING	1				0	0
120	K5763-31220	KIT COUPLER REPAIR	1				0	0

BEVEL GEAR CASE

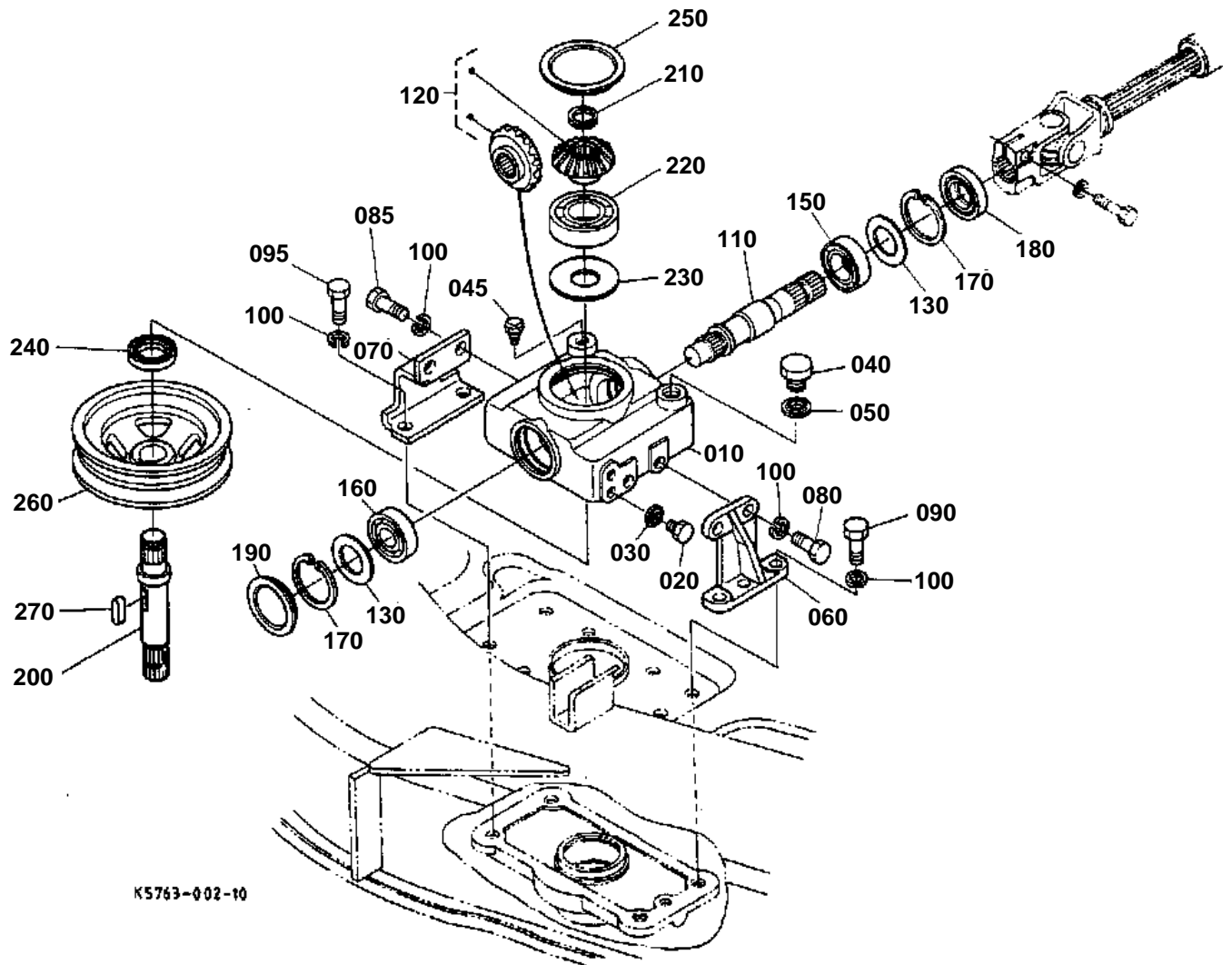

K5763-002-10



BEVEL GEAR CASE

↔ Interchangeable; ≠ not interchangeable; ← new for old; → old for new

REF.No	Part No.	Description	Q'ty	S.No.	I/C	REMARKS	Weight (kgf)	Weight (lb)
010	K5761-33114	CASE BEVEL GEAR	1				0	0
020	01153-50812	BOLT	2				0.008	0.0176
030	04717-00080	GASKET	2				0	0
040	06331-35016	PLUG	1				0.04	0.088
045	K5761-33250	PLUG	1				0.006	0.0132
050	04711-00300	GASKET	1				0.001	0.0022
060	K5763-33130	STAY CASE LH	1				0	0
070	K5763-33150	STAY CASE RH	1				0	0
080	K5763-33210	BOLT REAMER 30	2				0	0
085	01073-51225	BOLT	2				0.035	0.077
090	K5763-33230	BOLT REAMER 35	2				0	0
095	01073-51230	BOLT	2				0.041	0.0902
100	04512-50120	WASHER SPRING	8				0	0
110	K5763-33310	SHAFT PINION	1				0.66	1.452
120	K5763-33320	KIT GEAR BEVEL	1				0.45	0.99
130	36330-28410	SHIM	2				0.002	0.0044
130	36330-28420	SHIM	2				0.002	0.0044
150	08101-06205	BEARING	1				0.14	0.308
160	08101-06304	BEARING	1				0.146	0.3212
170	04611-00520	CIR CLIP	2				0.009	0.0198
180	76535-33440	SEAL OIL	1				0.02	0.044
190	63313-32270	CAP	1				0.03	0.066
200	K5763-33500	SHAFT BEVEL GEAR	1				0.55	1.21
210	04612-00220	CIR CLIP	1				0.001	0.0022
220	70712-33550	BEARING	1				0.22	0.484
230	70712-33570	SHIM	1				0.001	0.0022
230	76539-33410	SHIM	1				0.001	0.0022
240	K5761-33540	SEAL OIL	1				0.012	0.0264
250	7C765-51260	CAP	1				0.07	0.154
260	K5761-33520	PULLEY	1				1.73	3.806
270	05712-00728	KEY FEATHER	1				0.01	0.022

PULLEY HOLDER

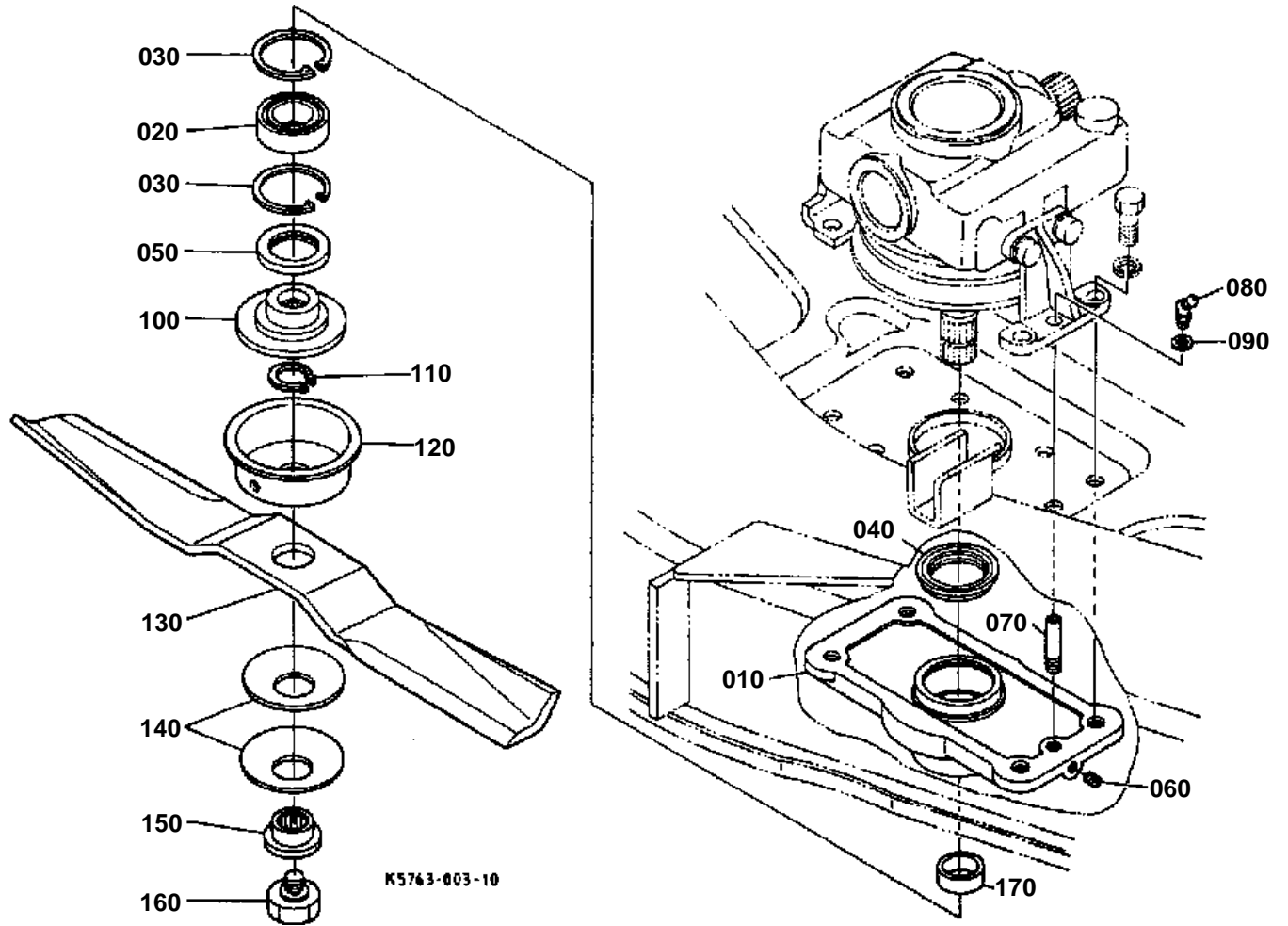



PULLEY HOLDER

↔ Interchangeable; ≠ not interchangeable; ← new for old; → old for new

REF.No	Part No.	Description	Q'ty	S.No.	I/C	REMARKS	Weight (kgf)	Weight (lb)
010	K5763-34110	HOLDER PULLEY CENTER	1				0	0
020	08101-06205	BEARING	1				0.14	0.308
030	04611-00520	CIR CLIP	2				0.009	0.0198
040	K5651-34120	OIL SEAL UPPER	1				0	0
050	K5651-34160	OIL SEAL LOWER	1				0	0
060	03410-50608	SCREW	1				0.001	0.0022
070	K5763-34130	PIPE EXTENSION	1				0	0
080	K5763-44250	NIPPLE GREASE 45DEG.	1				0	0
090	K5763-27340	SHIM ADJUST	1				0	0
100	K5761-34152	BOSS SPLINE	1				0.28	0.616
110	04612-00220	CIR CLIP	1				0.001	0.0022
120	K5651-34310	COVER DUST	1				0.1	0.22
130	K5651-34330	BLADE H20	1				1.6	3.52
140	K5651-34350	SPRING PLATE	2				0.07	0.154
150	76539-34392	BOSS SPLINE 2	1				0.06	0.132
160	K5651-34370	BOLT (M12*1.25)	1				0.08	0.176
170	K5763-33520	COLLAR CENTER	1				0	0

BLADE

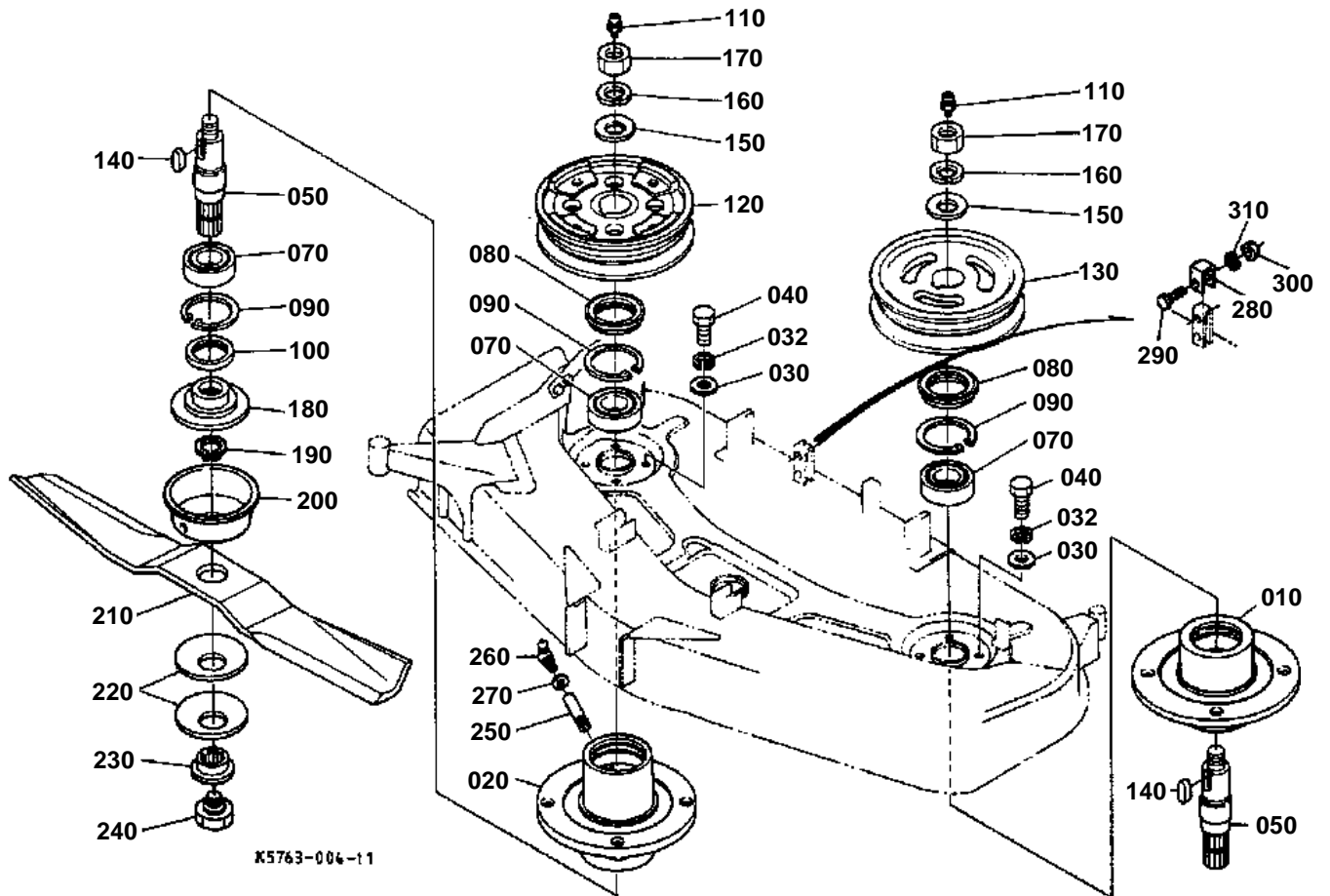

**BLADE**

↔ Interchangeable; ≠ not interchangeable; ← new for old; → old for new

REF.No	Part No.	Description	Q'ty	S.No.	I/C	REMARKS	Weight (kgf)	Weight (lb)
010	K5651-34510	HOLDER PULLEY SIDE	1				2.35	5.17
020	K5763-34520	HOLDER PULLEY RH	1				0	0
030	75599-32015	WASHER PLAIN (1/2)	8				0	0
032	04512-50120	WASHER SPRING	8				0	0
040	01073-51225	BOLT	8				0.035	0.077
050	K5651-34550	SHAFT SPINDLE	2				0.55	1.21
070	08101-06205	BEARING	4				0.14	0.308
080	K5651-34120	OIL SEAL UPPER	2				0	0
090	04611-00520	CIR CLIP	4				0.009	0.0198
100	K5651-34160	OIL SEAL LOWER	2				0	0
110	K1122-15150	NIPPLE GREASE	2			(M6 * 1.0)	0.002	0.0044
120	K5763-33570	PULLEY SIDE RH	1				0	0
130	K5651-33580	PULLEY SIDE	1				1.6	3.52
140	05712-00722	KEY FEATHER	2				0.009	0.0198
150	K5651-34560	WASHER PLAIN	2				0.024	0.0528
160	04512-50160	WASHER SPRING	2				0	0
170	02074-50160	NUT	2				0.029	0.0638
180	K5761-34152	BOSS SPLINE	2				0.28	0.616
190	04612-00220	CIR CLIP	2				0.001	0.0022
200	K5651-34310	COVER DUST	2				0.1	0.22
210	K5651-34330	BLADE H20	2				1.6	3.52
220	K5651-34350	SPRING PLATE	4				0.07	0.154
230	76539-34392	BOSS SPLINE 2	2				0.06	0.132
240	K5651-34370	BOLT (M12*1.25)	2				0.08	0.176
250	K5763-34130	PIPE EXTENSION	1				0	0
260	K5763-44250	NIPPLE GREASE 45DEG.	1				0	0
270	K5763-27340	SHIM ADJUST	1				0	0

TENSION PULLEY

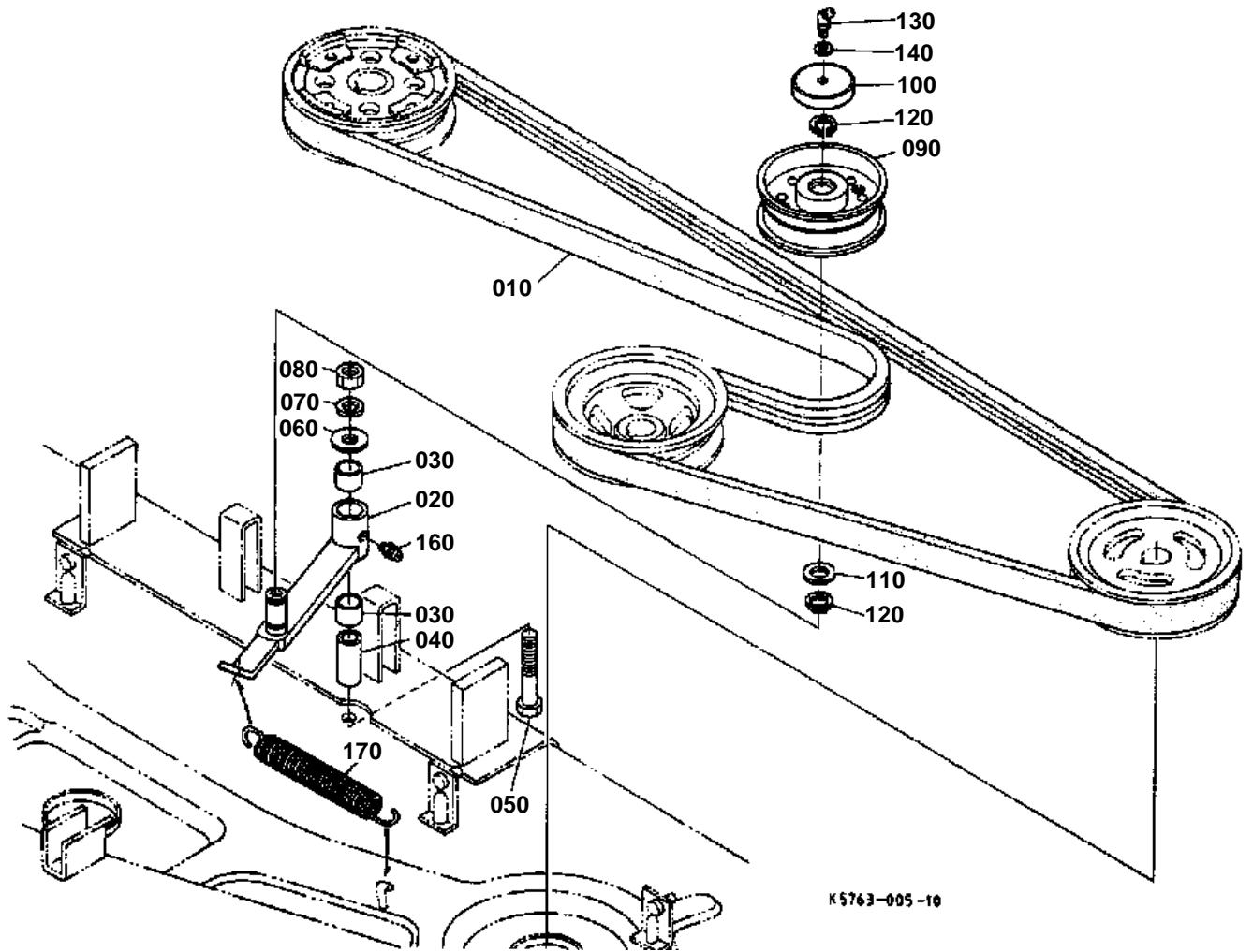



TENSION PULLEY

↔ Interchangeable; ≠ not interchangeable; ← new for old; → old for new

REF.No	Part No.	Description	Q'ty	S.No.	I/C	REMARKS	Weight (kgf)	Weight (lb)
010	K5763-34710	MULTI BELT 119	1				0	0
020	K5763-34730	ARM TENSION	1				0	0
030	K5651-20150	BUSHING TENSION	2				0.017	0.0374
040	K5651-34780	COLLAR TENSION	1				0.055	0.121
050	01073-51270	BOLT	1				0.06	0.132
060	75599-32015	WASHER PLAIN (1/2)	1				0	0
070	04512-50120	WASHER SPRING	1				0	0
080	02074-50120	NUT	1				0.015	0.033
090	K5651-34880	PULLEY TENSION	1				0.55	1.21
100	K5651-34790	COVER TENSION	1				0.02	0.044
110	K5651-34800	SEAL BEARING	1				0.001	0.0022
120	04612-00170	CIR CLIP	2				0.001	0.0022
130	K5763-12100	NIPPLE GREASE 45DEG.	1				0	0
140	K5763-27350	SHIM ADJUST	1				0	0
160	K1122-15150	NIPPLE GREASE	1			(M6 * 1.0)	0.002	0.0044
170	K5763-34750	SPRING TENSION	1				0	0

MOWER DECK

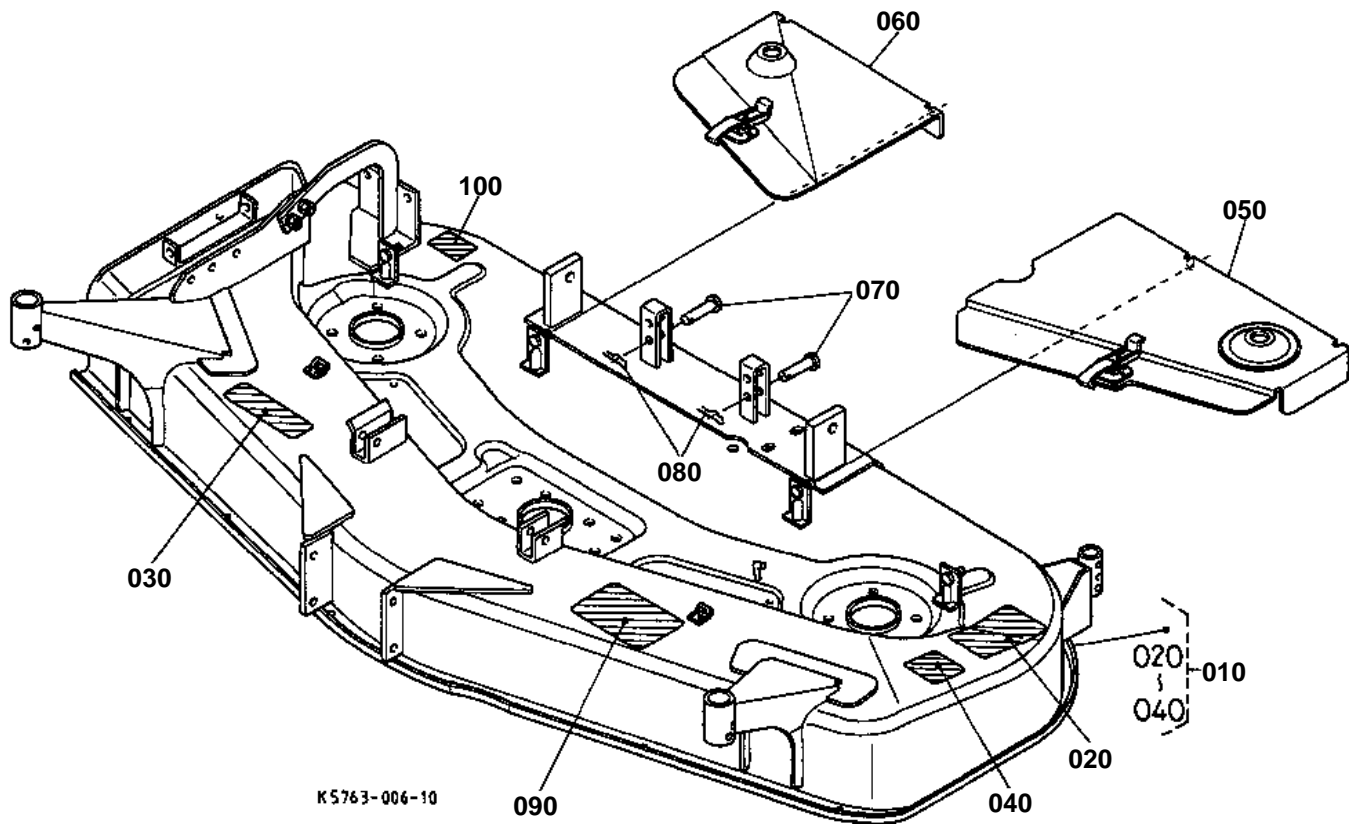



MOWER DECK

↔ Interchangeable; ≠ not interchangeable; ← new for old; → old for new

REF.No	Part No.	Description	Q'ty	S.No.	I/C	REMARKS	Weight (kgf)	Weight (lb)
010	K5763-41100	ASSY MOWER DECK	1				0	0
020	K5763-47150	LABEL CAUTION	1				0	0
030	K5112-73110	LABEL DANGER 1	1				0	0
040	K5112-73120	LABEL DANGER 2	1				0	0
050	K5763-41180	COVER LEFT	1				0	0
060	K5651-41200	COVER RIGHT	1				1.35	2.97
070	75599-51535	PIN CLEVIS	2			(1/2 * 1 / 3/4)	0	0
080	75599-56006	HAIRPIN COTTER	2				0	0
090	K5763-41190	LABEL HEIGHT	1				0	0
100	K5763-41170	PLATE NAME	1				0	0

FRONT GAUGE WHEEL

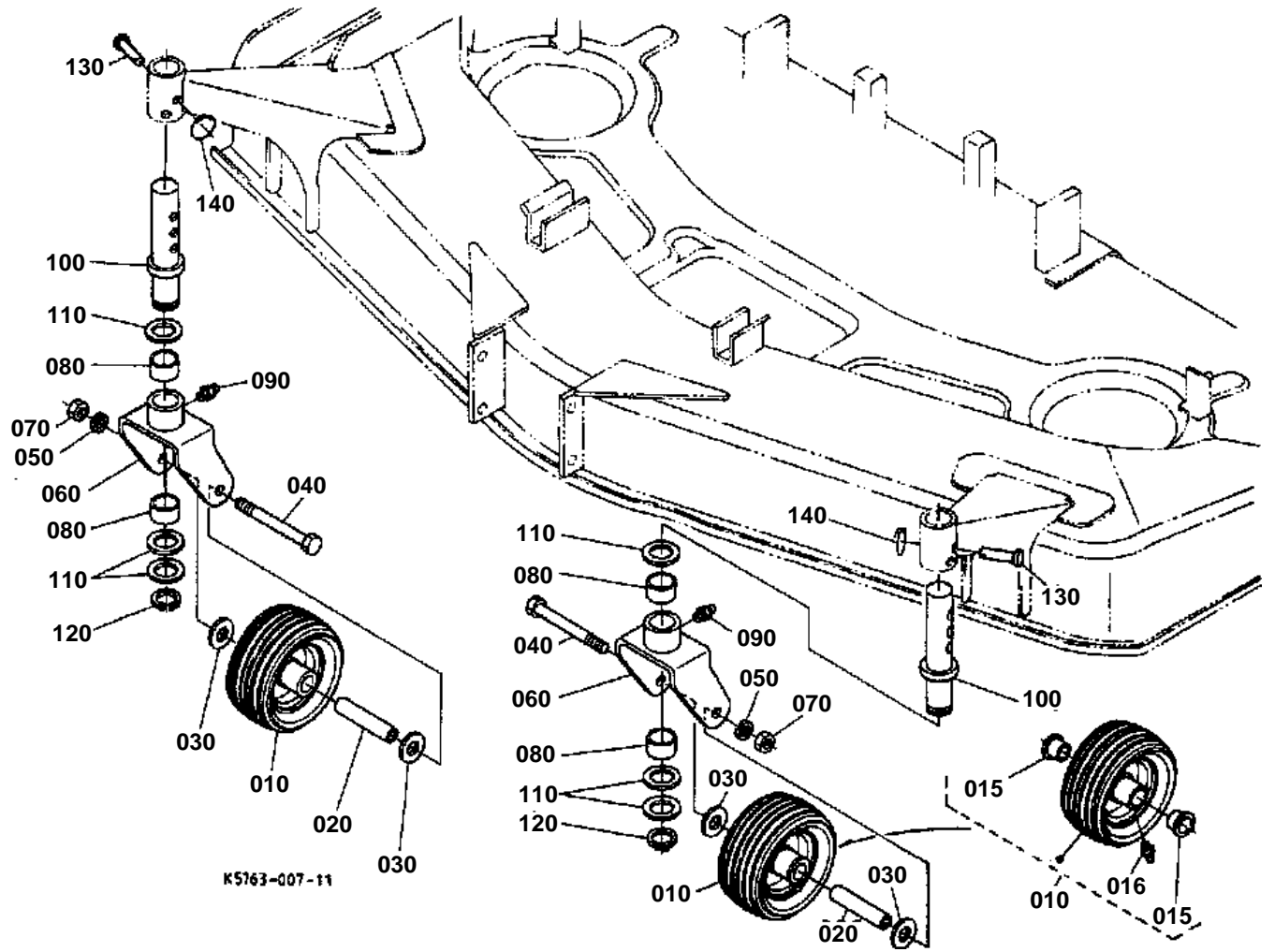



FRONT GAUGE WHEEL

↔ Interchangeable; ≠ not interchangeable; ← new for old; → old for new

REF.No	Part No.	Description	Q'ty	S.No.	I/C	REMARKS	Weight (kgf)	Weight (lb)
010	K5763-42110	ASSY WHEEL GAUGE	2			(6.25 * 3)	0	0
010	K5763-42130	ASSY WHEEL GAUGE	2		↔	(6.25 * 3)	0	0
015	K5763-74220	BUSHING 0.75 I.D.	4				0	0
015	K5763-74270	BUSHING 0.75 I.D.	4		≠		0	0
016	K5763-74230	NIPPLE GREASE	2				0	0
016	K5763-74280	NIPPLE GREASE	2		≠		0	0
020	K5763-42120	COLLAR WHEEL	2				0	0
030	75599-32018	WASHER PLAIN (3/4)	4				0.017	0.0374
040	01073-51204	BOLT	2				0	0
050	04512-50120	WASHER SPRING	2				0	0
060	K5763-34200	HOLDER GAUGE	2				0	0
070	02074-50120	NUT	2				0.015	0.033
080	K5763-42190	BUSHING GAUGE HOLDER	4				0	0
090	K1122-15150	NIPPLE GREASE	2			(M6 * 1.0)	0.002	0.0044
100	K5763-43110	SHAFT HOLDER	2				0	0
110	K5651-43150	COLLAR HOLDER	6				0.01	0.022
120	04612-00300	CIR CLIP	2				0.003	0.0066
130	75599-51345	PIN CLEVIS (3/8)	2				0	0
140	70712-51140	RING SNAP	2				0.009	0.0198

LINKAGE

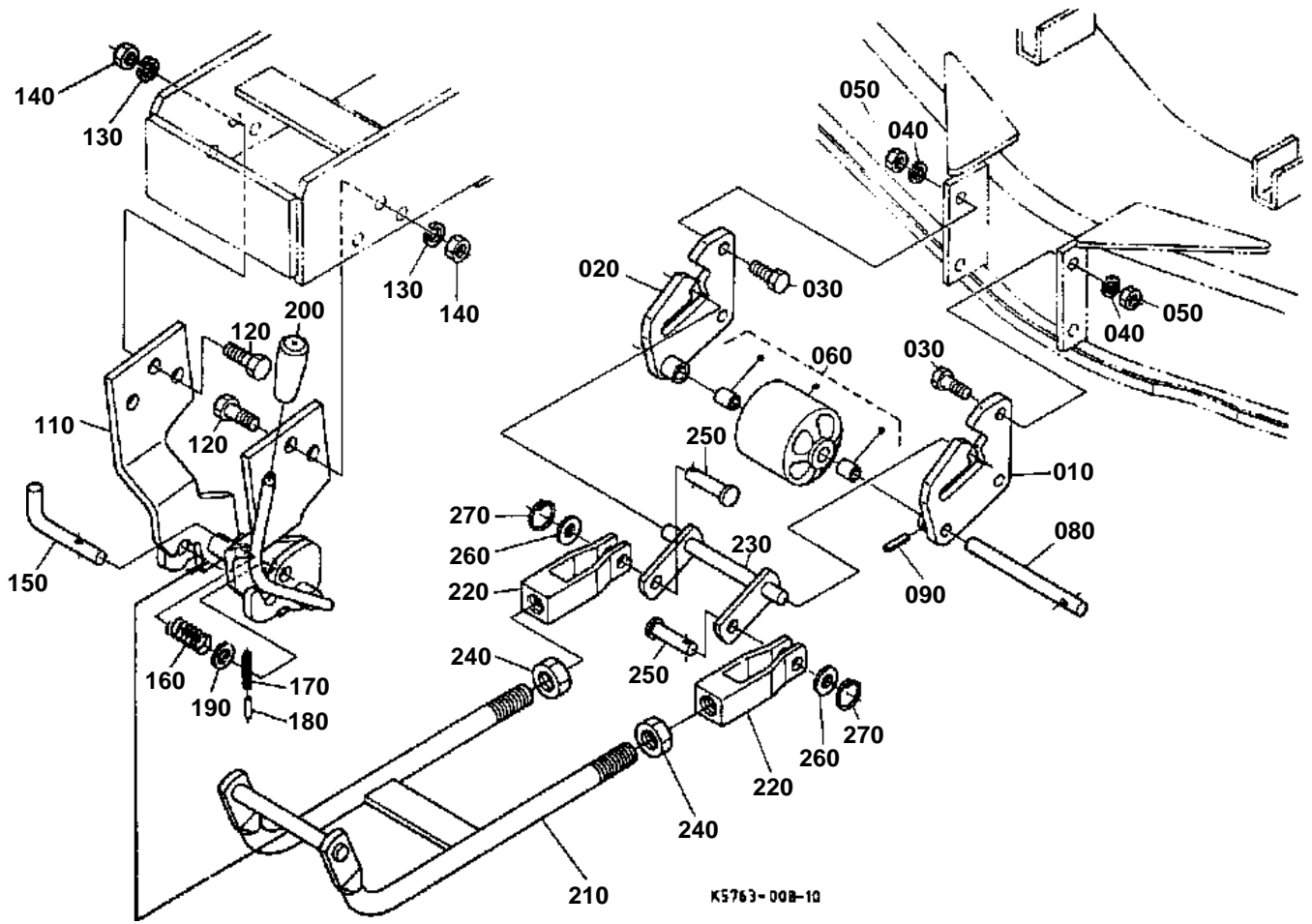

**LINKAGE**

↔ Interchangeable; ≠ not interchangeable; ← new for old; → old for new

REF.No	Part No.	Description	Q'ty	S.No.	I/C	REMARKS	Weight (kgf)	Weight (lb)
010	K5763-46110	BRACKET LH B	1				0	0
020	K5763-46120	BRACKET RH B	1				0	0
030	01073-51030	BOLT	4				0.028	0.0616
040	04512-50100	WASHER SPRING	4				0	0
050	02018-50100	NUT	4				0.011	0.0242
060	K5763-46250	ASSY ROLLER 3.0S	1				0	0
080	K5763-46170	PIN GAUGE FRONT	1				0	0
090	75599-52521	PIN SPRING	1			(7/32-3/4)	0	0
110	K5763-44510	STAY FRONT	1				0	0
120	01073-51435	BOLT	6				0.063	0.1386
130	75599-33016	WASHER SPRING LOCK	6				0.08	0.176
140	02074-50140	NUT	6				0.021	0.0462
150	K5763-44540	PIN FRONT	1				0	0
160	K5763-44560	SPRING PIN FRONT	1				0	0
170	75599-52532	PIN SPRING	1			(7/32 * 1 / 5/8)	0.005	0.011
180	75599-52225	PIN SPRING	1			(1/8 * 1 / 1/4)	0	0
190	75599-32016	WASHER PLAIN	1				0.009	0.0198
200	K5763-00120	GRIP LEVER	1				0	0
210	K5763-44610	LINK FRONT 1	1				0	0
220	K5763-44630	LINK FRONT 2	2				0	0
230	K5763-44670	LINK FRONT 3	1				0	0
240	75599-31069	HEX.NUT	2			(7/8 * 18UNF)	0	0
250	75599-51635	PIN CLEVIS	2			(9/16 * 1 / 3/4)	0	0
260	75599-32016	WASHER PLAIN	2				0.009	0.0198
270	70712-51140	RING SNAP	2				0.009	0.0198

REAR WHEEL

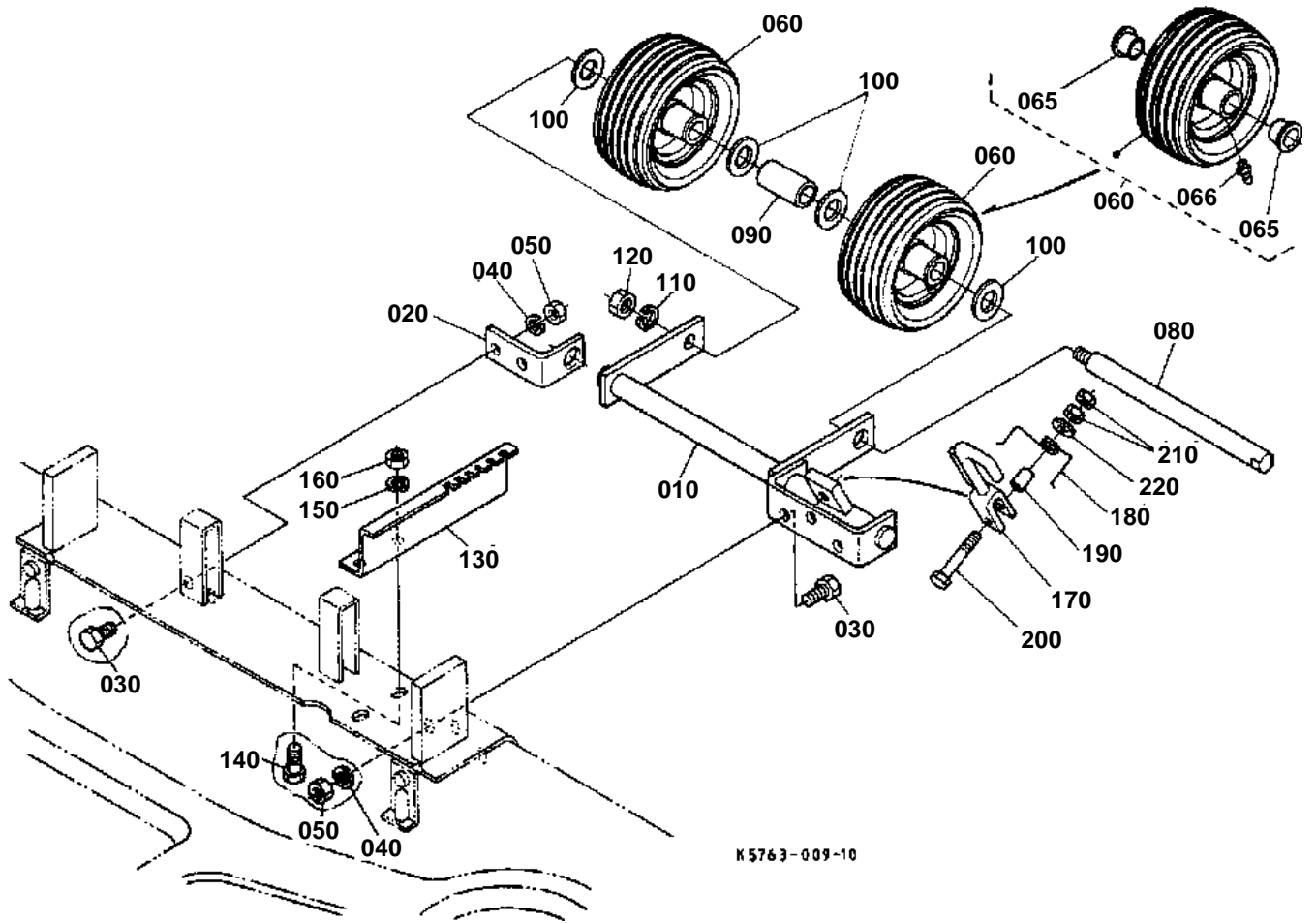

K 5763-009-10



REAR WHEEL

↔ Interchangeable; ≠ not interchangeable; ← new for old; → old for new

REF.No	Part No.	Description	Q'ty	S.No.	I/C	REMARKS	Weight (kgf)	Weight (lb)
010	K5763-44110	ARM REAR WHEEL	1				0	0
020	K5763-44130	BRACKET REAR WHEEL	1				0	0
030	01073-51025	BOLT	5				0.025	0.055
040	04512-50100	WASHER SPRING	5				0	0
050	02018-50100	NUT	5				0.011	0.0242
060	K5763-42110	ASSY WHEEL GAUGE	2			(6.25 * 3)	0	0
060	K5763-42130	ASSY WHEEL GAUGE	2		↔	(6.25 * 3)	0	0
065	K5763-74220	BUSHING 0.75 I.D.	4				0	0
065	K5763-74270	BUSHING 0.75 I.D.	4		≠		0	0
066	K5763-74230	NIPPLE GREASE	2				0	0
066	K5763-74280	NIPPLE GREASE	2		≠		0	0
080	K5763-44170	SHAFT REAR WHEEL	1				0	0
090	K5763-44180	COLLAR REAR WHEEL	1				0	0
100	75599-32018	WASHER PLAIN (3/4)	4				0.017	0.0374
110	04512-50120	WASHER SPRING	1				0	0
120	02074-50120	NUT	1				0.015	0.033
130	K5763-45110	PLATE GUIDE	1				0	0
140	01073-51025	BOLT	2				0.025	0.055
150	04512-50100	WASHER SPRING	2				0	0
160	02018-50100	NUT	2				0.011	0.0242
170	K5763-45170	LEVER REAR WHEEL	1				0	0
180	K5763-45190	SPRING RETURN	1				0	0
190	K5763-33190	COLLAR LEVER	1				0	0
200	01053-50860	BOLT	1				0.024	0.0528
210	02054-50080	NUT	2				0.005	0.011
220	75599-32012	WASHER PLAIN (5/16)	1				0.002	0.0044

DISCHARGE COVER

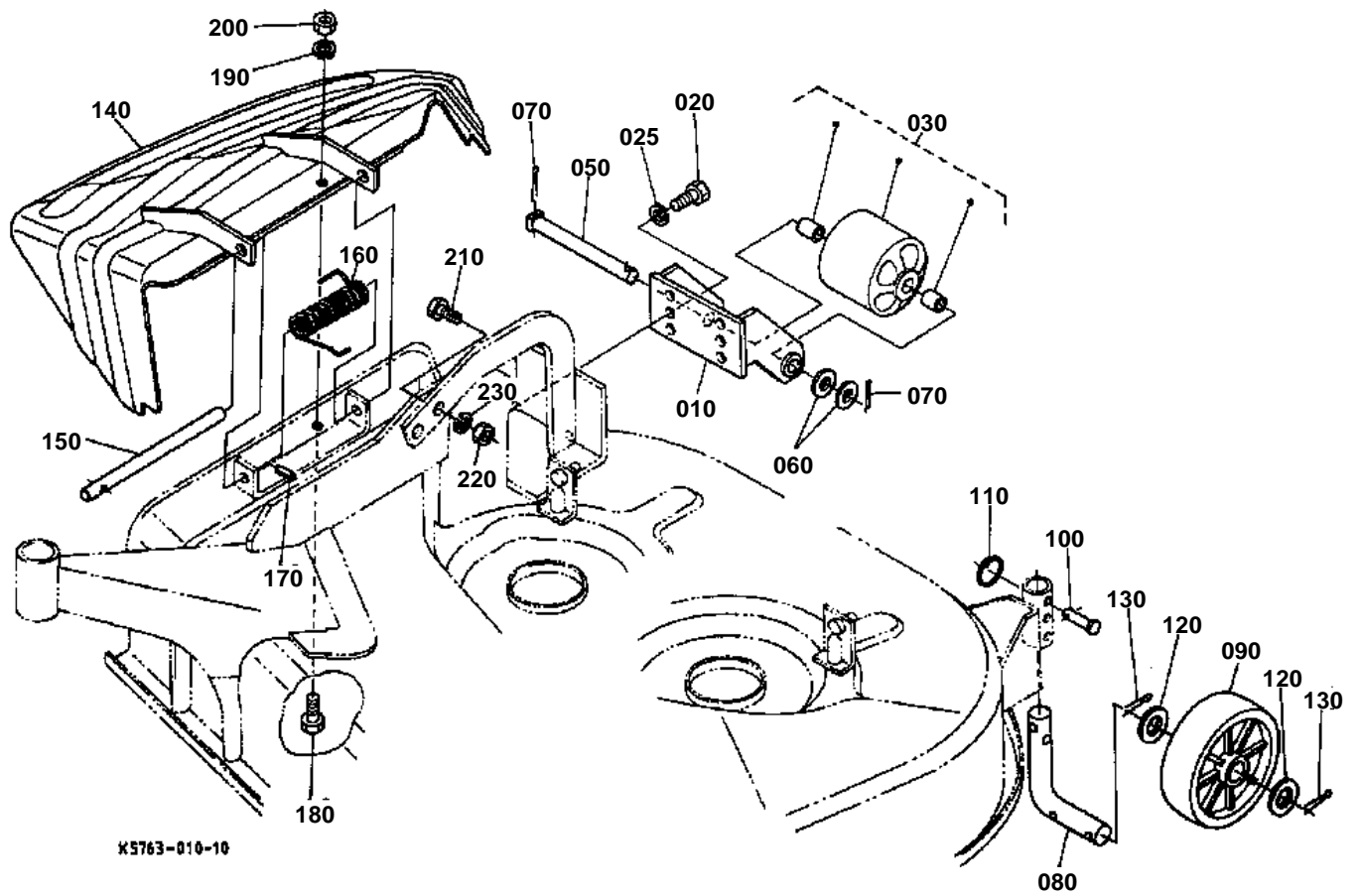



DISCHARGE COVER

↔ Interchangeable; ≠ not interchangeable; ← new for old; → old for new

REF.No	Part No.	Description	Q'ty	S.No.	I/C	REMARKS	Weight (kgf)	Weight (lb)
010	K5763-46140	SUPPORT STAY ROLLER	1				0	0
020	01073-51025	BOLT	2				0.025	0.055
025	04512-50100	WASHER SPRING	2				0	0
030	K5763-46250	ASSY ROLLER 3.0S	1				0	0
050	K5651-46180	PIN GAUGE	1				0.15	0.33
060	75599-32015	WASHER PLAIN (1/2)	2				0	0
070	75599-53173	PIN COTTER	2			(1/8 * 1)	0.002	0.0044
080	K5763-61690	SHAFT ROLLER LH	1				0	0
090	K5763-61700	ROLLER 5.0 * 1.5	1				0	0
100	75599-51227	PIN CLEVIS	1			(5/16 * 1 / 3/8)	0	0
110	K5142-72730	RING SNAP	1				0	0
120	75599-32018	WASHER PLAIN (3/4)	2				0.017	0.0374
130	75599-53194	PIN COTTER	2			(5/32 * 1 / 1/4)	0	0
140	K5651-47110	COVER DISCHARGE	1				4.8	10.56
150	K5651-47150	PIN DISCHARGE	1				0.2	0.44
160	K5651-47160	SPRING DISCHARGE	1				0.12	0.264
170	75599-52521	PIN SPRING	1			(7/32-3/4)	0	0
180	01073-51030	BOLT	1				0.028	0.0616
190	04512-50100	WASHER SPRING	1				0	0
200	02018-50100	NUT	1				0.011	0.0242
210	01073-51030	BOLT	2				0.028	0.0616
220	02018-50100	NUT	2				0.011	0.0242
230	04512-50100	WASHER SPRING	2				0	0

LIFT LINKAGE

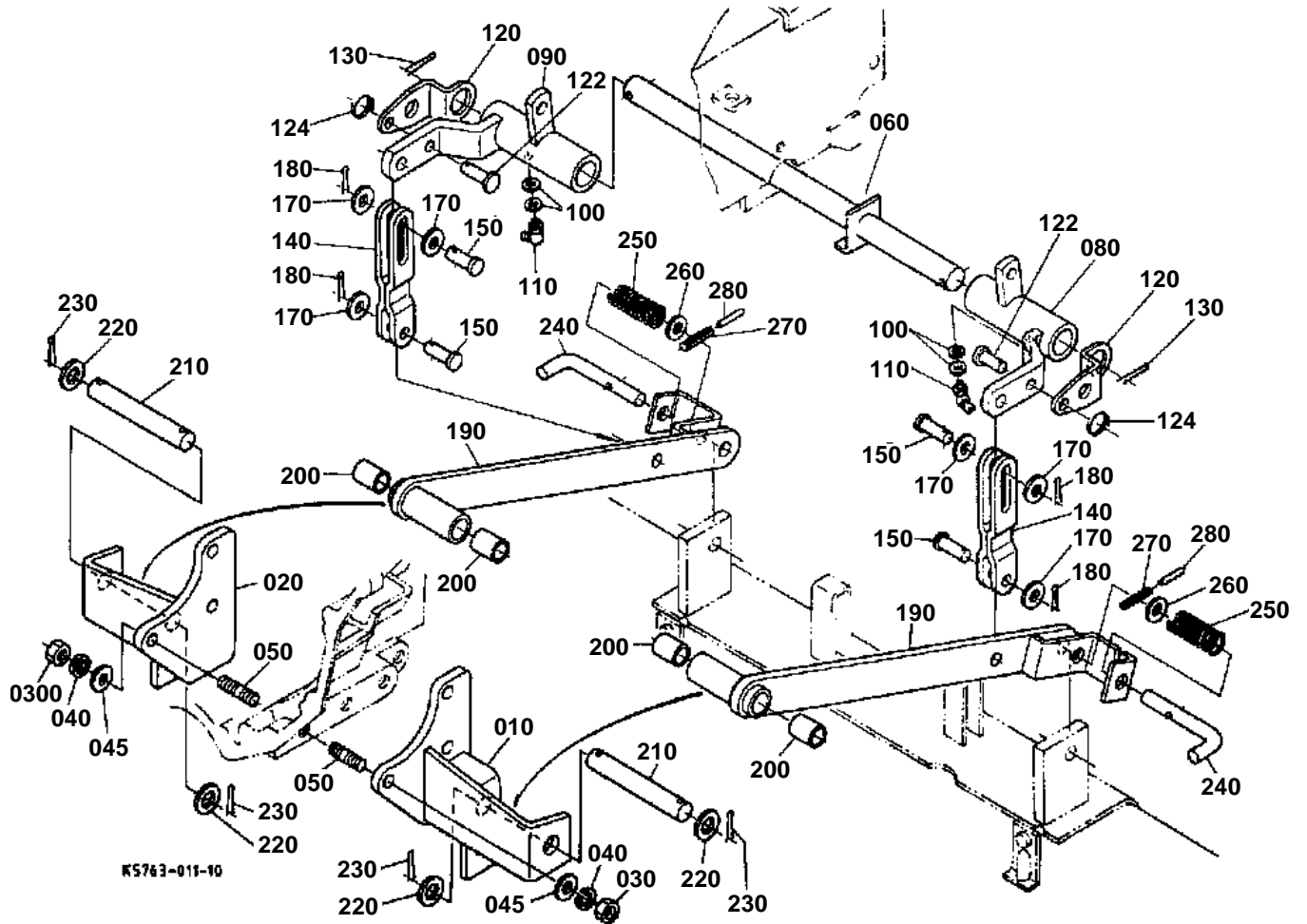

**LIFT LINKAGE**

↔ Interchangeable; ≠ not interchangeable; ← new for old; → old for new

REF.No	Part No.	Description	Q'ty	S.No.	I/C	REMARKS	Weight (kgf)	Weight (lb)
010	K5763-51110	STAY MID LH	1				0	0
020	K5763-51130	STAY MID RH	1				0	0
030	02074-50120	NUT	6				0.015	0.033
040	04512-50120	WASHER SPRING	6				0	0
045	K5763-14950	WASHER	6				0	0
050	01555-51230	STUD	6				0.04	0.088
060	K5763-51100	SHAFT LIFT	1				0	0
080	K5763-51190	ARM LIFT 2 LH	1				0	0
090	K5763-51210	ARM LIFT 2 RH	1				0	0
100	K5763-27340	SHIM ADJUST	4				0	0
110	K5763-44250	NIPPLE GREASE 45DEG.	2				0	0
120	K5763-51300	PLATE STOPPER	2				0	0
122	75599-51220	PIN CLEVIS	2			(5/16 * 1)	0	0
124	K5142-72730	RING SNAP	2				0	0
130	75599-53226	PIN COTTER	2			(7/32 * 1 / 3/4)	0	0
140	K5763-51250	LINK LIFT	2				0	0
150	75599-51530	PIN CLEVIS	4			(1/2 * 1 / 1/2)	0	0
170	75599-32015	WASHER PLAIN (1/2)	6				0	0
180	75599-53194	PIN COTTER	4			(5/32 * 1 / 1/4)	0	0
190	K5763-51290	LINK REAR	2				0	0
200	K5763-51280	BUSHING LINK	4				0	0
210	K5763-51160	PIN STAY	2				0	0
220	75599-32018	WASHER PLAIN (3/4)	4				0.017	0.0374
230	75599-53194	PIN COTTER	4			(5/32 * 1 / 1/4)	0	0
240	K5651-44650	PIN REAR	2				0.2	0.44
250	K5651-44670	SPRING PIN	2				0.21	0.462
260	75599-32016	WASHER PLAIN	2				0.009	0.0198
270	75599-52532	PIN SPRING	2			(7/32 * 1 / 5/8)	0.005	0.011
280	75599-52225	PIN SPRING	2			(1/8 * 1 / 1/4)	0	0

LIFT ARM

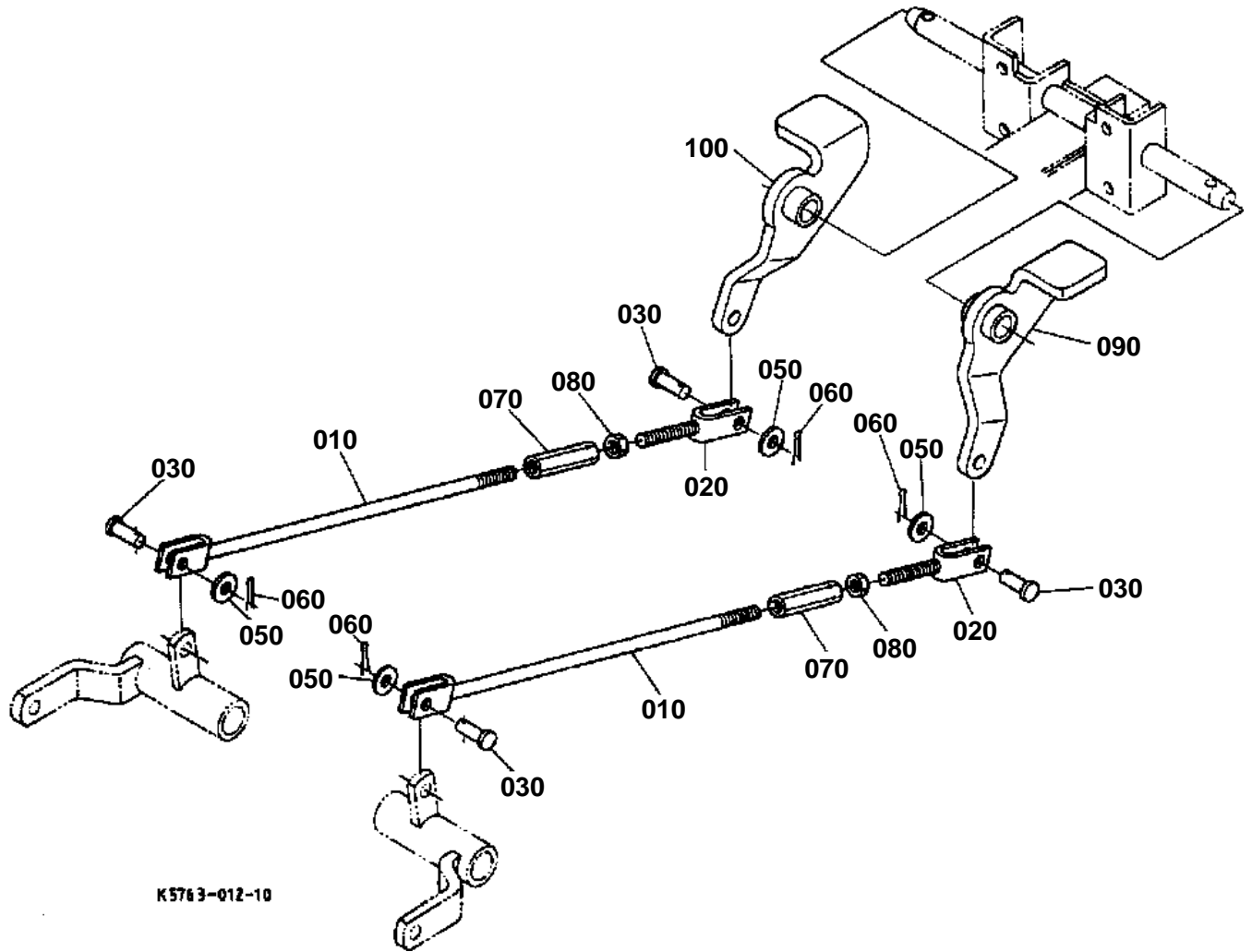

K5763-012-10



LIFT ARM

↔ Interchangeable; ≠ not interchangeable; ← new for old; → old for new

REF.No	Part No.	Description	Q'ty	S.No.	I/C	REMARKS	Weight (kgf)	Weight (lb)
010	K5763-61130	ROD LIFT L	2				0	0
020	K5763-61150	ROD LIFT S	2				0	0
030	75599-51525	PIN CLEVIS	4			(1/2 * 1 / 1/4)	0.2	0.44
050	75599-32015	WASHER PLAIN (1/2)	4				0	0
060	75599-53194	PIN COTTER	4			(5/32 * 1 / 1/4)	0	0
070	K5763-28980	TURNBUCKLE	2				0	0
080	02074-50120	NUT	2				0.015	0.033
090	K5763-61160	ARM LIFT 1 LH	1				0	0
100	K5763-61170	ARM LIFT 1 RH	1				0	0

IMAGE NOT AVAILABLE



ACCESSORIES AND SERVICE PARTS

↔ Interchangeable; ≠ not interchangeable; ← new for old; → old for new

REF.No	Part No.	Description	Q'ty	S.No.	I/C	REMARKS	Weight (kgf)	Weight (lb)
010	K5763-71110	OPERATOR'S MANUAL	1				0	0