

OPERATOR'S MANUAL

KUBOTA TRACTOR

MODELS B6200HST • B7200HST



F-3702

READ AND SAVE THIS MANUAL

Kubota®

(

(

9

(

FOREWORD

You are now the proud owner of a KUBOTA Tractor. This tractor is a product of KUBOTA quality engineering and manufacturing. It is made of the finest materials and under a rigid quality control system. It will give you long, satisfactory service. To obtain the best use of your tractor, please read this manual carefully. It will help you become familiar with the operation of the tractor and contains many helpful hints about tractor maintenance. It is KUBOTA's policy to utilize as quickly as possible every advance in our research. The immediate use of new techniques in the manufacture of products may cause some small parts of this manual to be outdated. KUBOTA distributors and dealers will have the most up-to-date information. Please do not hesitate to consult with them.



SAFETY FIRST

This symbol, the industry's "Safety Alert Symbol", is used throughout this manual and on labels on the tractor itself to warn of the possibility of personal injury. Read these instructions carefully. It is essential that you read the instructions and safety regulations before you attempt to assemble or use this unit.

ABBREVIATIONS LIST

Abbreviations	Definitions
2WD	Two Wheel Drive
4WD	Four Wheel Drive
API	American Petroleum Institute
ASAE	American Society of Agricultural Engineers, USA
ASTM	American Society for Testing and Materials, USA
DIN	Deutsches Institut für Normung, GERMANY
DT	Dual Traction [4WD]
HST	Hydrostatic Transmission
m/s	Meters Per Second
PT	Permanent Type (= Ethylene glycol anti-freeze)
PTO	Power Take Off
ROPS	Roll-Over Protective Structure
rpm	Revolutions Per Minute
r/s	Revolutions Per Second
SAE	Society of Automotive Engineers
SMV	Slow Moving Vehicle
SPT	Semi-Permanent Type
UDT	KUBOTA UDT fluid (Transmission-hydraulic fluid)

CONTENTS

▲ Safe Operation	1
1. Servicing of Tractor	6
2. Specifications	7
3. Specifications of Implement Limitations	10
4. Handling New Tractor	12
4.1 Loading and Unloading	12
5. Instrument Panel and Controls	13
5.1 Switches	13
5.2 Controls	15
5.3 Auxiliary Hydraulics	21
6. Three-point Hitch & Drawbar	22
7. Wheels, Tires and Ballast	23
7.1 Treads	24
7.2 Wheel Hub	25
7.3 Tires	25
7.4 Ballast	25
7.5 Toe-in	26
8. Operating Instructions	27
8.1 Operating the Engine	27
8.2 Operating the Tractor	28
8.3 Pulling	28
8.4 Check During Driving	29
8.5 Directions for Operating	29
9. Maintenance	30
9.1 Daily Check	30
9.2 Lubricants	30
9.3 Maintenance Check List	31
10. Check and Maintenance	32
10.1 Fuel	32
10.2 Engine Oil	33
10.3 Transmission Fluid	34
10.4 Changing Front Axle Differential Case Oil (4WD) ...	35
10.5 Changing Front Axle Gear Case Oil (Right and Left) (4WD)	36
10.6 Oiling and Greasing Points before Starting	36
10.7 Radiator	37
10.8 Air Cleaner	40
10.9 Cleaning Air Filter Element	40
10.10 Battery	40
11. Adjustments	42
11.1 Fan Drive Belt	42
11.2 Clutch	42
11.3 Brake	42
11.4 Steering Wheel	42
12. Troubleshooting	43
12.1 Engine Troubleshooting	43
12.2 Tractor Troubleshooting	44
12.3 Battery Troubleshooting	45
13. Long-Term Storage	46
14. Options	46
15. Lubricant Specifications	47
16. Wiring Diagram	48

INDEX



SAFE OPERATION

Careful operation is your best insurance against an accident. Read this section carefully before operating the tractor. All operators, no matter how much experience they may have had, should read this and other related manuals before operating tractor or any implement attached to it. It is the owner's legal obligation to instruct all operators in safe operation.

1. BEFORE OPERATING THE TRACTOR

- (1) Know your equipment and its limitations. Read this entire manual before attempting to start and operate the tractor.
- (2) Pay special attention to the warning and caution labels on the tractor itself.
- (3) Kubota recommends the use of a Roll Over Protective Structures (ROPS) and seat belt in almost all applications. This combination will reduce the risk of serious injury or death should the tractor be upset. If the ROPS is loosened or removed for any reason, make sure that all parts are reinstalled correctly before operating the tractor.

Never modify or repair a ROPS because welding, bending, drilling, grinding, or cutting any portion may weaken the structure.

A damaged ROPS structure must be replaced, not repaired or revised. If any structural member of the ROPS is damaged, replace the entire structure at your local Kubota dealer.

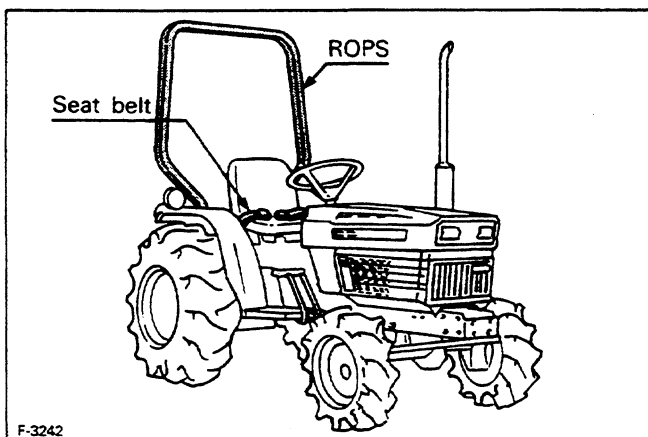

- (4) Always use the seat belt if the tractor has a ROPS. Do not use it if there is no ROPS. Check the seat belt daily and replace if frayed or damaged.
- (5) Do not operate tractor or any implement attached to it while under the influence of alcohol, medication, or other substances or while fatigued.
- (6) Carefully check the vicinity before operating tractor or any implement attached to it. Check for overhead clearance which may interfere with a ROPS. Do not allow any bystanders around or near tractor during operation.

- (7) Before allowing other people to use your tractor, explain how to operate and have them read this manual before operation.
- (8) Never wear loose, torn, or bulky clothing around tractor. It may catch on moving parts or controls, leading to the risk of accident. Use additional safety items.....hard hat, safety boots or shoes, eye and hearing protection, gloves, etc.....as appropriate or required.
- (9) Do not allow passengers or non-qualified operators on the tractor at any time. The operator must remain in the tractor seat throughout operation.
- (10) Check brakes, clutch, and other mechanical parts for faulty adjustment and wear. Replace worn or damaged parts promptly. Check the tightness of all nuts and bolts regularly. (For further details, see MAINTENANCE AND ADJUSTMENTS.)
- (11) Keep your tractor clean. Dirt, grease, and trash accumulations contribute to fires and lead to personal injury.
- (12) Use only implements meeting the specifications listed under IMPLEMENT LIMITATIONS in this manual. Use proper weights to front or rear of tractor to reduce the risk of upsets. Follow the safe operating procedures specified in the manuals included with the equipment.
- (13) The narrower the tread, the greater, the risk of a tractor upset. For maximum stability, adjust the wheels to the largest practical tread width. (See page 24).

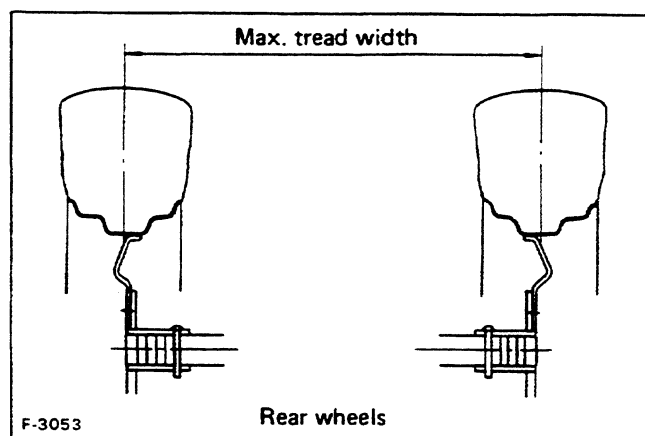

F-3053

Rear wheels

2. OPERATING THE TRACTOR

- (1) Never start engine or operate levers from anywhere other than the seat.
- (2) Before starting the engine, make sure that all levers (including auxiliary control levers) are in their neutral positions, that the parking brake is engaged, and that both the clutch and the Power Take-Off (PTO) are disengaged.

Fasten the seat belt if the tractor has a ROPS.

- (3) Do not start engine by shorting across starter terminals or bypassing the safety start switch. Machine may start in gear and move if normal starting circuitry is bypassed.
- (4) Pull only from the drawbar or hitch. Never hitch to axle housing or any other point except drawbar; such arrangements only increase the risk of serious personal injury or death due to a tractor upset. (fixed or swinging type)

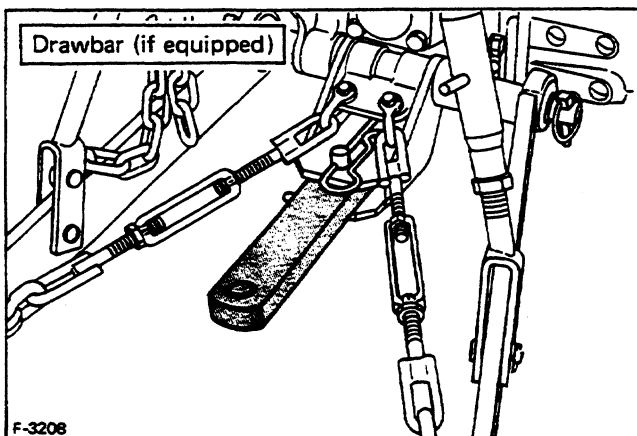

- (5) Do not operate or idle engine in a non-ventilated area. Carbon monoxide gas is colorless, odorless, and deadly.
- (6) Keep all shields and guards in place. Replace any that are missing or damaged.
- (7) Avoid sudden starts. To avoid upsets, slow down when turning, on uneven terrain, and before stopping.
- (8) The tractor cannot turn with the differential locked and attempting to do so could be dangerous.
- (9) Do not operate near ditches, holes, embankments, or other terrain features which may collapse under the tractor's weight. The risk of tractor upset is even higher when the ground is loose or wet.
- (10) Driving forward out of a ditch or mire or up a steep slope risks a tractor upset backward. Always back out of these situations. Extra caution is required with four-wheel drive models because their higher traction can give the operator false confidence in the tractor's ability to climb slopes.
- (11) To avoid upsets, always back up steep slopes. Stay off hills and slopes too steep for safe operation.
- (12) Watch where you are going at all times. Watch for and avoid obstacles. Be alert at row ends, near trees, and other obstructions.
- (13) When working in groups, always let the others know what you are going to do before you do it.

- (14) Never "freewheel". Disengaging the clutch or shifting into neutral while descending a slope could lead to a loss of control.
- (15) Never try to get on or off a moving tractor.

3. DRIVING THE TRACTOR ON THE ROAD

- (1) Lock the two brake pedals together to help assure straightline stops. Uneven braking at road speeds could cause the tractor to roll over.

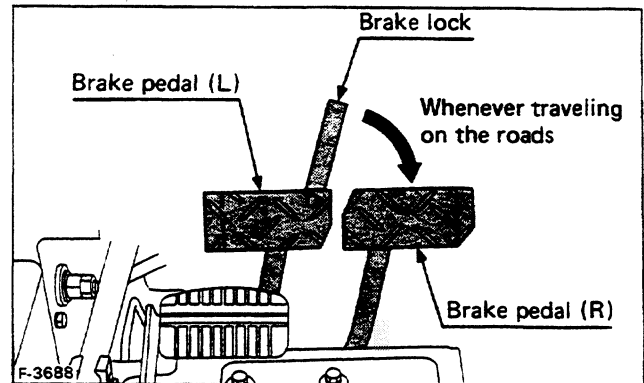

- (2) Always slow the tractor down before turning. Turning at high speed may tip the tractor over.
- (3) Make sure that the Slow-Moving Vehicle (SMV) emblem is clean and visible. Use hazard lights as required.

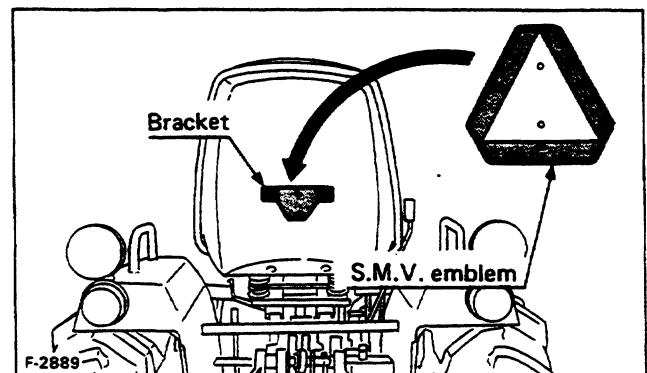

- (4) Observe all local traffic and safety regulations.
- (5) Turn the headlights on. Dim them when meeting another vehicle.
- (6) Drive at speeds that allow you to maintain control at all times.
- (7) Do not apply the differential lock while traveling at road speeds. The tractor may run out of control.
- (8) Avoid sudden motions of the steering wheel as they can lead to a dangerous loss of stability. The risk is especially great when the tractor is traveling at road speeds.
- (9) Do not operate an implement while the tractor is on the road. Lock it in the raised position.
- (10) When towing other equipment, use a safety chain and place an SMV emblem on it as well.

4. STOPPING THE TRACTOR

- (1) Disengage the PTO, lower all implements, place all control levers in their neutral positions, apply parking brake, turn off the engine, and remove the key.
- (2) Make sure that the tractor has come to a complete stop before dismounting.

5. OPERATING THE PTO

- (1) Wait until all moving components have completely stopped before getting off the tractor, connecting, disconnecting, adjusting, cleaning, or servicing any PTO driven equipment.
- (2) Keep the PTO shaft cover in place at all times. Replace the PTO shaft cap when the shaft is not in use.

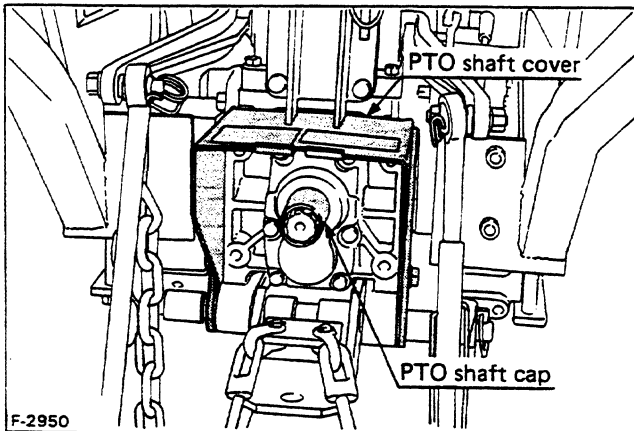

- (3) Before installing or using PTO driven equipment, read the manufacturer's manual and review the safety labels attached to the equipment.
- (4) To prevent PTO driven equipment from racing out of control, stick to the lower (Rear:540rpm, Mid:1546rpm) speed unless the higher (Rear:858rpm, Mid:2455rpm) one is specifically recommended as safe by the equipment manufacturer.

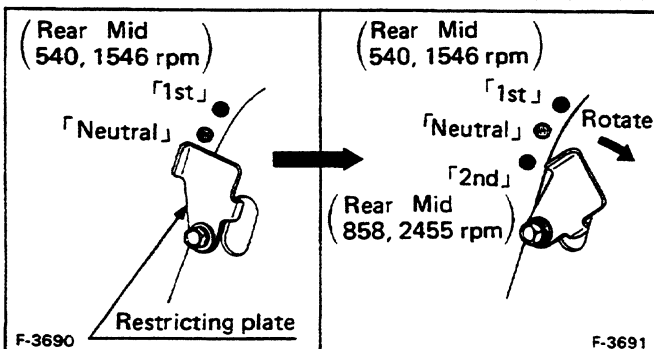
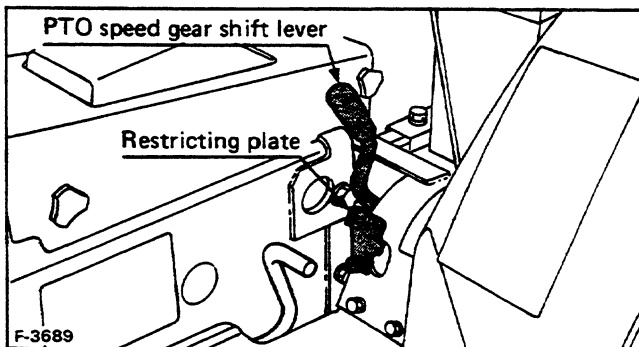

- (5) When operating stationary PTO driven equipment, always apply the tractor parking brake and place chocks behind and in front of the rear wheels. Stay clear of all rotating parts.

6. USING 3-POINT HITCH

- (1) Use the 3-point hitch only with equipment designed for 3-point hitch usage.

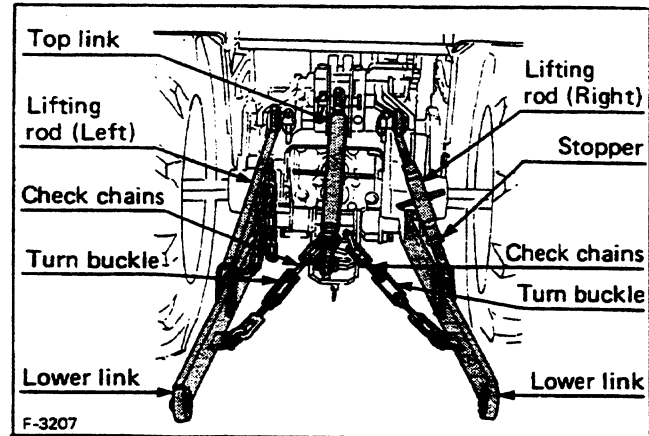

- (2) When using a 3-point hitch mounted implement, be sure to install the proper counterballast weight on the front of the tractor.
- (3) When transporting on the road, set the implement lowering control in the "lock" position to hold the implement in the raised position.

7. SERVICING THE TRACTOR

Before servicing the tractor, park it on a firm level surface, set the parking brake, place the gear shift lever in neutral and stop the engine.

- (1) Allow the tractor time to cool off before working on or near the engine, muffler, radiator, etc.
- (2) Always stop the engine before refueling. Avoid spills and overfilling.
- (3) Do not smoke when working around battery or when refueling. Keep all sparks and flames away from battery and fuel tank. The battery presents an explosion hazard because it gives off hydrogen and oxygen....especially when recharging.
- (4) Before "jumping" a dead battery, read and follow all of the instructions.(See page 4)
- (5) Keep first aid kit and fire extinguisher handy at all times.
- (6) Do not remove radiator cap while coolant is hot. When cool, slowly rotate cap to the first stop and allow sufficient time for excess pressure to escape before removing the cap completely. If the tractor has a coolant recovery tank, add coolant there instead of to the radiator.

- (7) Disconnect the battery's ground cable before working on or near electric components.
- (8) To avoid sparks from an accidental short circuit, always disconnect the battery's ground cable \ominus first and connect it last.

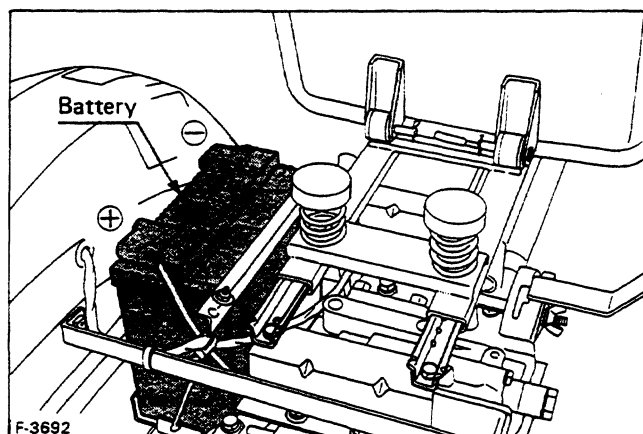

- (9) Do not attempt to mount a tire on a rim unless qualified to do so and all proper safety precautions are followed.
- (10) Provide adequate support when changing wheels or the wheel tread width.
- (11) Make sure that wheel bolts have been tightened to the specified torque.
- (12) Escaping hydraulic fluid under pressure has sufficient force to penetrate skin, causing serious personal injury. Before disconnecting hydraulic lines, be sure to release all residual pressure. Before applying pressure to the hydraulic system, make sure that all connections are tight and that all lines, pipes, and hoses are free of damage.

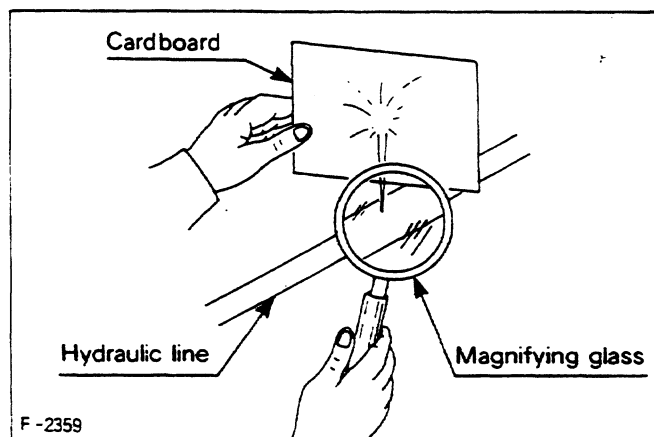

Fluid escaping from pinholes may be invisible. Do not use hands to search for suspected leaks; Use a piece of cardboard or wood, instead. Use of safety goggles or other eye protection is also highly recommended. If injured by escaping fluid, see a medical doctor at once. This fluid can produce gangrene or severe allergic reaction.

8. JUMP STARTING INSTRUCTIONS AND PRECAUTIONS

If ice is present or the battery is cracked, DO NOT ATTEMPT TO "JUMP START" vehicle.

- (1) Bring helper vehicle with a battery of the same voltage as disabled tractor within easy cable reach. "THE VEHICLES MUST NOT TOUCH".
- (2) Engage the parking brakes of both vehicles and put the shift levers in neutral. Turn both key switches off.
- (3) Put on safety goggles and rubber gloves.
- (4) Remove the vent caps from both batteries.
- (5) Cover vent holes with damp rags. Do not allow the rag to touch the battery terminals.
- (6) Attach the red clamp to the positive (red, \oplus or pos.) terminal of the dead battery and clamp the other end of the same cable to the positive (red, \oplus or pos.) terminal of the helper battery.
- (7) Clamp the other cable to the negative (black, \ominus or neg.) terminal of the helper battery.
- (8) Clamp the other end to the engine block or frame of the disabled tractor as far from the dead battery as possible.
- (9) Start the helper vehicle and let its engine run for a few moments. Start the disabled tractor.
- (10) Disconnect the jumper cables in the exact reverse order of attachment. (Steps 8, 7 and 6).
- (11) Remove and discard the damp rag. Reinstall the vent caps.

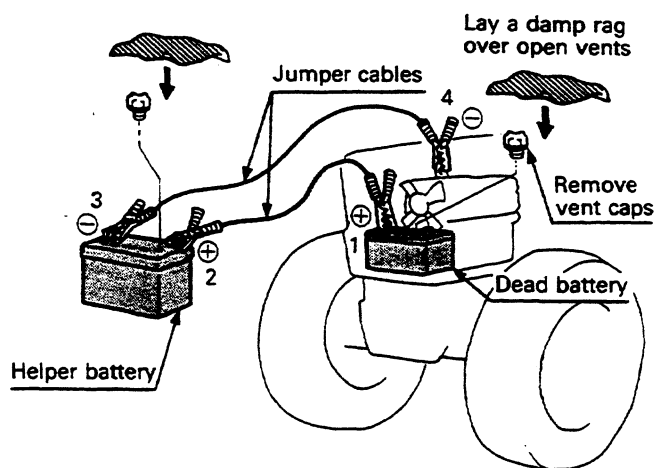

Connect cables in numerical order.
Disconnect in reverse order after use.

F-4727

9. TRACTOR SAFETY LABELS

① Part No. 35260-3491-2

⚠ CAUTION

TO AVOID PERSONAL INJURY:

1. Read and understand the operator's manual before operation.
2. Before starting the engine, make sure that everyone is at a safe distance from the tractor and that the PTO is OFF.
3. Do not allow passengers on the tractor at any time.
4. Before allowing other people to use the tractor, have them read the operator's manual.
5. Check the tightness of all nuts and bolts regularly.
6. Keep all shield in place and stay away from all moving parts.
7. Lock the two brake pedals together before driving on the road.
8. Slow down for turns, or rough roads, or when applying individual brakes.
9. On public roads use SMV emblem and hazard lights, if required by local traffic and safety regulations.
10. Pull only from the drawbar or hitch.
11. Before dismounting, stop the engine, set the parking brake, and lower the implement

④ Part No. 35260-2978-2

⚠ WARNING

TO AVOID PERSONAL INJURY OR DEATH FROM ROLL-OVER:

1. Kubota recommends the use of a Roll-Over Protective Structures (ROPS) and seat belt in almost all applications.
2. Remove the ROPS only when it substantially interferes with operation or itself presents a safety risk. (Examples include work in orchards and vineyards.)
ALWAYS REINSTALL IT BEFORE USING THE TRACTOR IN OTHER APPLICATIONS.
3. Never use just the seat belt, or just the ROPS. They must be used together. For further details, consult your Operator's Manual or your local dealer.

⑥ Part No. 35200-2534-1

⚠ WARNING

TO AVOID PERSONAL INJURY:

1. Keep PTO shield in place at all times.
2. Do not operate the PTO at speeds faster than the speed recommended by the implement manufacturer.

② Part No. 67061-4724-1

⚠ WARNING

Do not start engine with speed set lever or speed control pedal engaged.

③ Part No. 35820-9863-2

⚠ WARNING

AVOID POSSIBLE INJURY OR DEATH FROM A MACHINE RUNAWAY.

1. Do not start engine by shorting across starter terminals or by-passing the safety start switch. Machine may start in gear and move if normal starting circuitry bypassed.
2. Start engine only from operator's seat with transmission and PTO in neutral. Never start engine while standing on ground.

⑤ Part No. 35260-2979-1

⚠ WARNING

TO AVOID PERSONAL INJURY:

1. Attach pulled or towed loads to the drawbar only.
2. Use the 3-point hitch only with equipment designed for 3-point hitch usage.

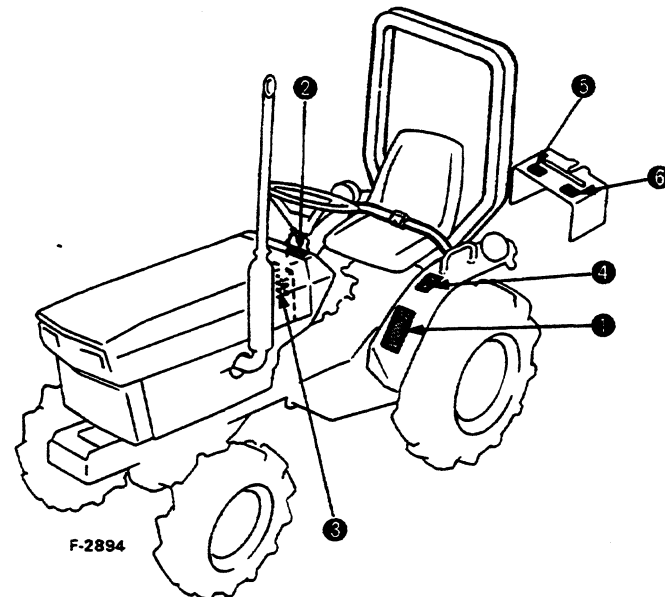

CARE OF WARNING AND CAUTION LABELS

- (1) Keep warning and caution labels clean and free from obstructing material.
- (2) Clean warning and caution labels with soap and water, dry with a soft cloth.
- (3) Replace damaged or missing warning and caution labels with new labels from your Kubota dealer.
- (4) If a component with warning and caution label (s) affixed is replaced with new part, make sure new label (s) is (are) attached in the same location (s) as the replaced component.
- (5) Mount new warning and caution labels by applying on a clean dry surface and pressing any bubbles to outside edge.

1. SERVICING OF TRACTOR

Your dealer is interested in your new tractor and has the desire to help you get the most value from it. After reading this manual thoroughly, you will find that you can do some of the regular maintenance yourself.

However, when in need of parts or major service, be sure to see your KUBOTA dealer.

For service, contact the KUBOTA Dealership from which you purchased your tractor or your local authorized KUBOTA dealer.

When in need of parts, be prepared to give your dealer both the tractor and engine serial numbers.

The tractor serial number is located on the transmission housing on the left hand side of the tractor. The engine serial number is located on the engine crankcase, right side.

Locate the serial numbers now and record them in the space provided.

**KUBOTA B620HSTE (2WD)/B620HSTD (4WD)
B720HSTE (2WD)/B720HSTD (4WD)**

Tractor Serial No. _____

Engine Serial No. _____

Date of Purchase _____

(To be filled in by purchaser)

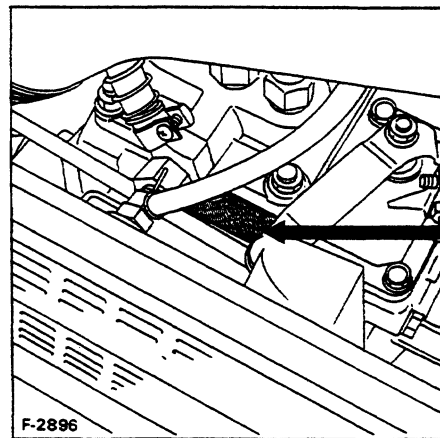
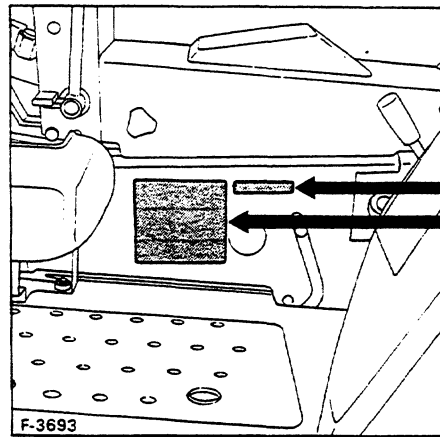

2. SPECIFICATIONS

Model		B6200HSTE (2WD)			B6200HSTD (4WD)			
Engine gross power		11.2kW (15HP)*						
PTO power		9.3kW (12.5HP)*						
Engine	Model	D850						
	Type	Vertical, water-cooled, 4-cycle diesel						
	No. of cylinders	3						
	Bore and stroke	72mm x 70mm (2.8 in. x 2.7 in.)						
	Total displacement	855cm ³ (52.2 cu.in.)						
	Rated revolution	41.7r/s (2500 rpm)						
	Fuel	Diesel fuel No. 2-D [No. 1 diesel fuel if temperature is below -10°C (15°F)]						
	Starter	Electric starter with battery, glow plug and decompression device, 12V, 0.8kW						
	Lubrication	Forced lubrication by trochoidal pump						
	Cooling	Water with pressurized radiator (natural circulation)						
	Battery	12V (45 Ah)						
Capacities	Fuel tank	20ℓ (5.3 U.S. gals.)						
	Engine crankcase	3.1ℓ (3.3 U.S. qts.)						
	Engine coolant	2.8ℓ (3.0 U.S. qts.)						
	Transmission case	13.5ℓ (14.3 U.S. qts.)						
	Steering gear box	0.2ℓ (0.2 U.S. qt.)						
	Front axle diff. case	—			0.5ℓ (0.5 U.S. qt.)			
	Front axle gear case	—			0.15ℓ (0.15 U.S. qt.)			
Tires	Front	Farm 4.50-10	Farm 5.00-10	Turf 18x9.50-8	Farm 5-12	Farm 6-12 B	Turf 20.5x8.00-10	
	Rear	7-16	8-16	29x12.00-15	7-16	8-16	29x12.00-15	
Dimensions	Overall length	mm (in.)	2590 (102.0)	2590 (102.0)	* 2590 (102.0)	2590 (102.0)	2590 (102.0)	2590 (102.0)
	Overall width	mm (in.)	910 (35.8)	990 (39.0)	1140 (44.9)	940 (37.0)	980 (38.6)	1140 (44.9)
		mm (in.)	960 (37.8)	1110 (43.7)		960 (37.8)	1110 (43.7)	
	Overall height with muffler	mm (in.)	1795 (70.7)	1815 (71.5)	1785 (70.3)	1810 (71.3)	1825 (71.9)	1800 (70.9)
	Wheel base	mm (in.)	1470 (57.9)	1470 (57.9)	1470 (57.9)	1470 (57.9)	1470 (57.9)	1470 (57.9)
	Min. ground clearance	mm (in.)	230 (9.1)	255 (10.0)	240 (9.4)	230 (9.1)	240 (9.4)	215 (8.3)
Treads	Front	mm (in.)	710 (28.0)	710 (28.0)	850 (33.5)	785 (30.9)	795 (31.3)	825 (32.5)
	Rear	mm (in.)	740 (29.1) 790 (31.1) 910 (35.8)	790 (31.1) 910 (35.8)	840 (33.1)	740 (29.1) 790 (31.1) 910 (35.8)	790 (31.1) 910 (35.8)	840 (33.1)
Weight	kg (lbs.)	525 (1158)	535 (1180)	545 (1202)	580 (1279)	595 (1312)	600 (1323)	
PTO shaft	Rear PTO	Transmission case rear (rear PTO), Transmission case bottom (mid PTO) and engine front (front PTO) SAE 1-3/8 (with over running clutch) 2 speeds (9.0 and 14.3 r/s at 41.9 engine r/s) (540 and 858 rpm at 2517 engine rpm)						
	Mid PTO	USA No.5 (KUBOTA 10 tooth) Involute spline 2 speeds (25.8 and 40.9 r/s at 41.9 engine r/s) (1546 and 2455 rpm at 2517 engine rpm)						
Clutch	Dry single plate							
Steering	Ball screw type							
Transmission	Main-hydrostatic transmission, High-Low gear shift (2 forward, 2 reverse)							
Min. turning radius	m (feet)	2.1 (6.9)			2.3 (7.5)			
Brake	Internal expanding type, right and left independent with interlocking device							
Differential	Bevel gear							

Note: *Manufacturer's estimate

Model		B7200HSTE (2WD)				B7200HSTD (4WD)				
Engine gross power		12.7kW (17HP)*								
PTO power		10.5kW (14HP)*								
Engine	Model	D950								
	Type	Vertical, water-cooled, 4-cycle diesel								
	No. of cylinders	3								
	Bore and stroke	75mm x 70mm (3.0 in. x 2.8 in.)								
	Total displacement	927cm ³ (56.6 cu.in.)								
	Rated revolution	41.7 r/s (2500 rpm)								
	Fuel	Diesel fuel No. 2-D [No. 1 diesel fuel, if temperature is below -10°C (15°F)]								
	Starter	Electric starter with battery, glow plug and decompression device, 12V, 0.8kW								
	Lubrication	Forced lubrication by trochoidal pump								
	Cooling	Water with pressurized radiator								
Battery		12V (45 Ah)								
Capacities	Fuel tank	20ℓ (5.3 U.S. gals.)								
	Engine crankcase	3.1ℓ (3.3 U.S. qts.)								
	Engine coolant	2.8ℓ (3.0 U.S. qts.)								
	Transmission case	13.5ℓ (14.3 U.S. qts.)								
	Steering gear box	0.2ℓ (0.2 U.S. qt.)								
	Front axle diff. case	—				1.5ℓ (1.6 U.S. qts.)				
	Front axle gear case	—				0.5ℓ (0.5 U.S. qt.)				
Tires	Front	Farm 5.00-10	Farm 5.00-10	Turf 18x9.50-8	Turf 18x9.50-8	Farm 6-12B	Farm 6-12	Turf 20.5x8.00-10	Turf 20.5x8.00-10	
	Rear	8-16	9.5-16	29x12.00-15	31x13.5-15	8-16	9.5-16	29x12.00-15	31x13.5-15	
Dimensions	Overall length	mm (in.)	2590 (102.0)	2590 (102.0)	2590 (102.0)	2590 (102.0)	2590 (102.0)	2590 (102.0)	2590 (102.0)	
	Overall width	mm (in.)	990 (39.0)	1045 (41.1)	1140 (44.9)	1240 (48.8)	1050 (41.3)	1095 (43.1)	1140 (44.9)	1240 (48.8)
		mm (in.)	1110 (43.7)	1145 (45.1)	1265 (49.8)		1110 (43.7)	1145 (45.1)	1265 (49.8)	
	Overall height with muffler	mm (in.)	1815 (71.5)	1815 (71.5)	1785 (70.3)	1785 (70.3)	1830 (72.0)	1840 (72.4)	1805 (71.1)	1805 (71.1)
	Wheel base	mm (in.)	1470 (57.9)	1470 (57.9)	1470 (57.9)	1470 (57.9)	1470 (57.9)	1470 (57.9)	1470 (57.9)	1470 (57.9)
	Min. ground clearance	mm (in.)	255 (10.0)	285 (11.2)	240 (9.4)	250 (9.8)	240 (9.4)	255 (10.0)	215 (8.5)	215 (8.5)
	Treads	Front	mm (in.)	710 (28.0)	710 (28.0)	850 (33.5)	850 (33.5)	860 (33.9)	860 (33.9)	895 (35.2)
Rear		mm (in.)	790 (31.1)	795 (31.3)	840 (33.1)	895 (35.2)	790 (31.1)	795 (31.3)	840 (33.1)	895 (35.2)
		mm (in.)	910 (35.8)	845 (33.3)		910 (35.8)	845 (33.3)		895 (35.2)	1015 (40.0)
Weight	kg (lbs.)	535 (1180)	550 (1213)	545 (1202)	550 (1213)	605 (1334)	615 (1356)	610 (1345)	615 (1356)	
PTO shaft		Transmission case rear (rear PTO), Transmission case bottom (mid PTO) and engine front (front PTO)								
	Rear PTO	SAE 1-3/8 (with over running clutch) 2 speeds (9.0 and 14.3 r/s at 41.9 engine r/s) (540 and 858 rpm at 2517 engine rpm)								
	Mid PTO	USA No.5 (KUBOTA 10 tooth) Involute spline 2 speeds (25.8 and 40.9 r/s at 41.9 engine r/s) (1546 and 2455 rpm at 2517 engine rpm)								
Clutch	Dry single plate									
Steering	Ball screw type									
Transmission	Main-hydrostatic transmission, High-Low gear shift (2 forward, 2 reverse)									
Min. turning radius	m (feet)	2.1 (6.9)				2.2 (7.2)				
Brake	Internal expanding type, right and left independent with interlocking device									
Differential	Bevel gear									

Note: *Manufacturer's estimate

■ Traveling Speeds

Model		B6200HST		
Tire sizes		7-16	8-16	29 x 12.00-15
Forward	Low	4.46 km/h (2.77 mph)	4.76 km/h (2.96 mph)	4.56 km/h (2.83 mph)
	High	11.40 km/h (7.08 mph)	12.17 km/h (7.56 mph)	11.66 km/h (7.25 mph)
Reverse	Low	3.34 km/h (2.08 mph)	3.57 km/h (2.20 mph)	3.42 km/h (2.13 mph)
	High	8.55 km/h (5.31 mph)	9.12 km/h (5.67 mph)	8.74 km/h (5.43 mph)

[at 41.7 engine r/s (2500 engine rpm)]

Model		B7200HST			
Tire sizes		8-16	9.5-16	29 x 12.00-15	31 x 13.5-15
Forward	Low	4.76 km/h (2.69 mph)	5.09 km/h (3.16 mph)	4.56 km/h (2.83 mph)	4.71 km/h (2.93 mph)
	High	12.17 km/h (7.56 mph)	13.01 km/h (8.09 mph)	11.66 km/h (7.25 mph)	12.04 km/h (7.49 mph)
Reverse	Low	3.57 km/h (2.20 mph)	3.82 km/h (2.37 mph)	3.42 km/h (2.13 mph)	3.53 km/h (2.20 mph)
	High	9.12 km/h (5.67 mph)	9.76 km/h (6.07 mph)	8.74 km/h (5.43 mph)	9.03 km/h (5.61 mph)

[at 41.7 engine r/s (2500 engine rpm)]

(Specifications and design subject to change without notice)

3. SPECIFICATIONS OF IMPLEMENT LIMITATIONS

The Kubota tractor has been thoroughly tested for proper performance with implements sold or approved by us. Use with implements which exceed the maximum specifications listed below, or which are otherwise unfit for use with the Kubota tractor may result in malfunctions or failures of the tractor, damage to other property and injury to the operator or others. [Any malfunctions or failures of the tractor resulting from use with improper implements are not covered by the warranty.]

Model		B6200HST	B7200HST
Operating condition		General control operation (Flat ground and slope condition)	
Lower link end max. loading weight W_0		Below 180 kg (400 lbs.)	
Actual figures	Implement weight W_1	As in the following list	
	Trailer loading weight W_2	Below 500 kg (1100 lbs.) (without brake) Below 1000 kg (2200 lbs.) (with brake)	

Lower link end max. loading weight..... The max. allowable load which can be put on the lower link end: W_0
 Implement weight The implement's weight which can be put on the lower link: W_1
 Trailer loading weight The max. loading weight for trailer (without trailer's weight): W_2

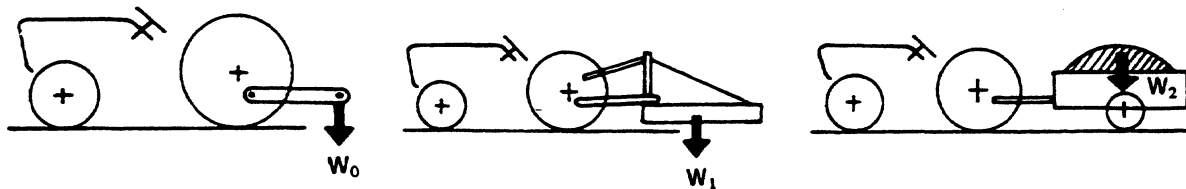

Implement		Remarks	B6200HST	B7200HST
Rotary mower	Rear (1 Blade)	Max. cutting width Max. weight	1070 mm (42 in.) 140 kg (300 lbs.)	1070 mm (42 in.) 140 kg (300 lbs.)
	Rear Mid (2-3 Blade)	Max. cutting width Max. cutting width Max. weight	1220 mm (48 in.) 1220 mm (48 in.) 140 kg (300 lbs.)	1220 mm (48 in.) 1520 mm (60 in.) 140 kg (300 lbs.)
	Sickle bar	Max. cutting width	1220 mm (48 in.)	1220 mm (48 in.)
Rotary tiller		Max. tilling width Max. weight	1070 mm (42 in.) 170 kg (380 lbs.)	1070 mm (42 in.) 180 kg (400 lbs.)
Bottom plow		Max. size	300 mm (12 in.) x 1	360 mm (14 in.) x 1
Disc plow		Max. size	560 mm (22 in.) x 1	560 mm (22 in.) x 1
Cultivator		Max. size	1220 mm (48 in.) (1 row)	1220 mm (48 in.) (1 row)
Disc harrow		Max. harrowing width Max. weight	1220 mm (48 in.) 90 kg (200 lbs.)	1370 mm (54 in.) 140 kg (300 lbs.)
Sprayer		Max. tank capacity	100 ℓ (30 gals.)	110 ℓ (30 gals.)
Front blade		Max. cutting width Sub frame Oil pressure, relief valve	1220 mm (48 in.) Necessary 11.4 MPa (116 kgf/cm ² , 1650 psi)	1220 mm (48 in.) Necessary 11.4 MPa (116 kgf/cm ² , 1650 psi)
Rear blade		Max. cutting width Max. weight	1520 mm (60 in.) 140 kg (300 lbs.)	1520 mm (60 in.) 160 kg (350 lbs.)
Front loader		Max. lifting capacity Max. width Sub frame	270 kg (600 lbs.) 1070 mm (42 in.) Necessary	270 kg (600 lbs.) 1070 mm (42 in.) Necessary
Box blade		Max. cutting width Max. weight	1070 mm (42 in.) 170 kg (380 lbs.)	1070 mm (42 in.) 170 kg (380 lbs.)
Backhoe		Max. digging depth Max. weight Sub frame	1830 mm (72 in.) 270 kg (600 lbs.) Necessary	1830 mm (72 in.) 270 kg (600 lbs.) Necessary
Snow blower		Max. working width Max. weight Sub frame	1070 mm (42 in.) 160 kg (350 lbs.) Necessary	1220 mm (48 in.) 160 kg (350 lbs.) Necessary
Trailer		Max. load capacity	500 kg (1100 lbs.)	500 kg (1100 lbs.)
Three point lift		Max. load capacity	180 kg (400 lbs.)	180 kg (400 lbs.)

4. HANDLING NEW TRACTOR

How a new tractor is handled and maintained determines the life of the tractor.

A new tractor just off the factory production line has been, of course, well fitted and tested, but the various parts are not accustomed to severe types of work, so care should be taken to operate the tractor for the first 100 hours at a slower speed and avoid excessive work or operation until the various parts become well "broken-in." The manner in which the tractor is handled during the "breaking-in" period greatly affects the life of your tractor. Therefore, to obtain the maximum performance and the longest life of the tractor, it is very important to properly break-in your tractor.

In handling a new tractor the following precautions should be well observed.

■ Operation during the breaking-in period

- Do not start quickly nor apply the brakes suddenly.
- In winter, operate the tractor after fully warming up the engine.
- Do not run the engine at speeds faster than necessary.
- On rough roads, slow down to suitable speeds. Do not operate the tractor at fast speed.

■ Changing lubricating oil for new tractors

The lubricating oil is specially important in the case of a new tractor. The various parts are not "broken-in" and are not accustomed to each other; small metal grit may develop during the operating of the tractor; and this may wear out or damage the parts. Therefore, care should be taken to exchange the lubricating oil a little earlier than would ordinarily be required.

For further details of exchange interval hours, see check list page 31.

■ Read "Safe Operation"

Please read "Safe Operation" before attempting to start or operate the tractor.

4.1 LOADING AND UNLOADING

- (1) When loading (or unloading) a tractor onto a truck or trailer, chock the truck or trailer's tires.
- (2) Securely fix a rugged ramp with non-skids to the truck or trailer bed and check to see that there are no people around before starting to load or unload the tractor.
- (3) Always back the tractor when going up the ramp.

5. INSTRUMENT PANEL AND CONTROLS

5.1 SWITCHES

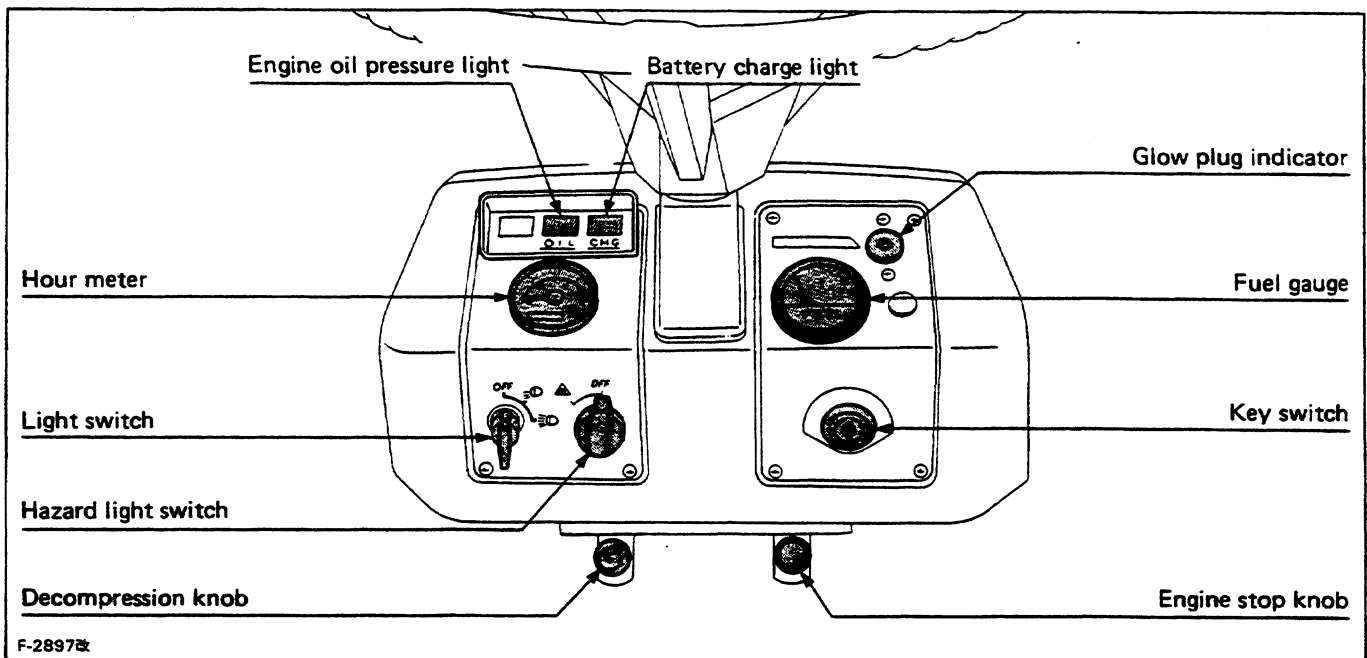

■ Key Switch

Inserting the key and turning it one click to the right, closes the electrical circuit and lights up the engine oil pressure lamp and the battery charge light (RED). Depress the clutch pedal to disengage the clutch. Next, turning the key left activates the glow plug (preheating coil), proceeding to preheat the combustion chamber. After the glow plug light has turned red and the engine has been preheated completely, turn the key switch to the far right and the cell starter will start to rotate and the engine should start. Release the key switch and it will return to the ON position.

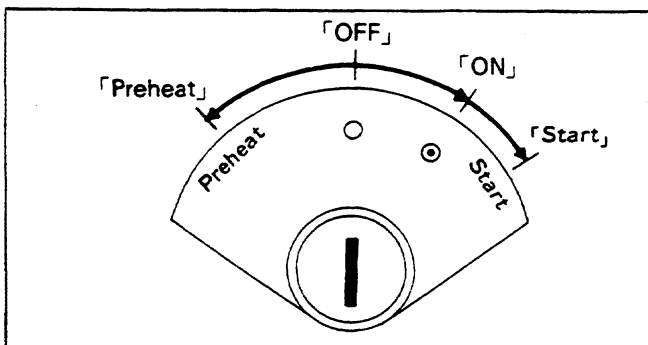

IMPORTANT:

- Because of the safety device, the engine may not be started except when the clutch is disengaged.

■ Glow Plug Indicator (Pre-heating Indicator)

When the starter switch is turned to the left, the glow plug indicator becomes red. This shows the condition of pre-heating in the combustion chamber.

■ Light Switch

Turning the light switch one click to the right illuminates the dim headlights. Next, turning it one more click illuminates the bright headlights.

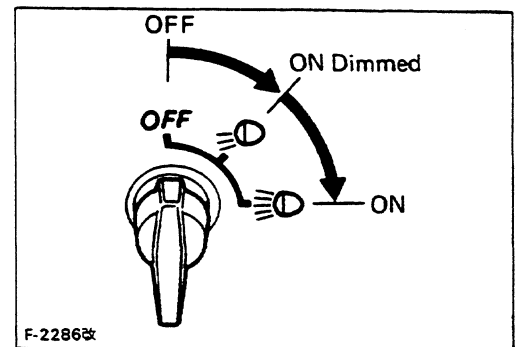

■ Hazard Light Switch

When the hazard light switch is turned counter clockwise, the hazard lights flash.

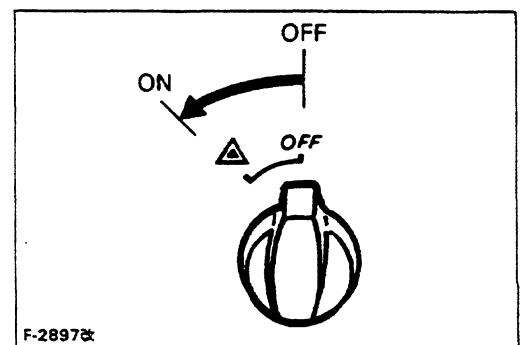

■ Horn Button (if equipped)

The horn will sound only when the key is in the "ON" position.

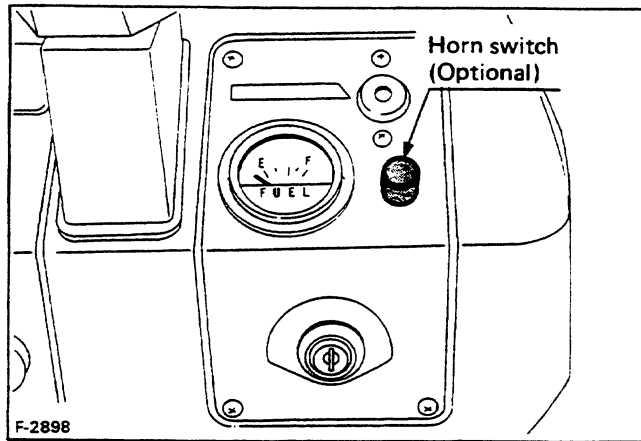

■ Hour Meter

This meter shows the number of hours the tractor has been operated at rated engine rpm.

The last digit (white background) indicates 1/10 of an hour. The time in minutes will be shown by multiplying by six to last digit on white background.

Example **170.1** ... 170 hours 6 minutes used
Moving hand indicates the revolution per minute of the engine.

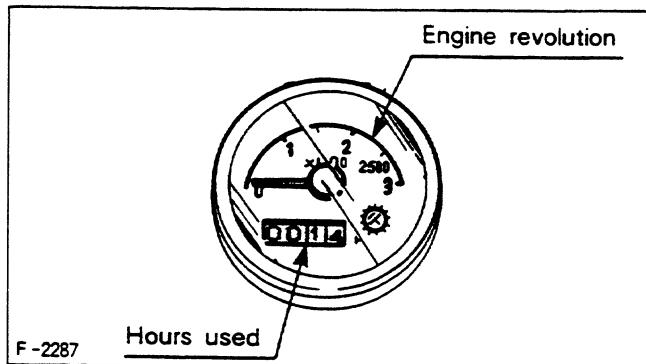

■ Decompression Knob

To assist in cold weather starting, or starting with a weak battery, the following procedures should be used:

- Set throttle to proper starting position.
- Preheat engine.
- Pull out the decompression knob.
- Engage starter and allow engine RPM to build up.
- While cranking engine, push decompression knob back in to allow engine to start.

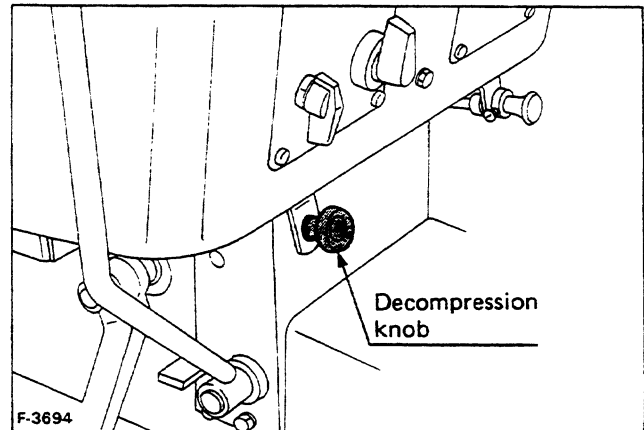

■ Engine Oil Pressure Light

The engine oil light indicates low engine oil pressure when the lamp is on and proper engine oil pressure when the lamp is off.

The light illuminates when the key switch is turned on. It goes off when the engine starts and engine oil begins to circulate normally. If the light stays on even after the engine starts, immediately stop the engine, and check the cause of the trouble.

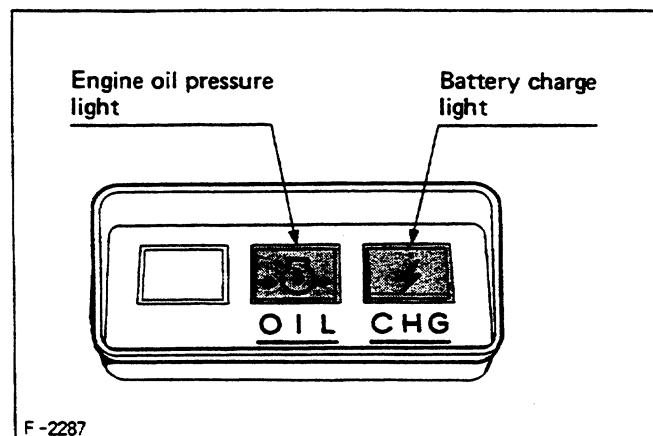

■ Battery Charge Light

The battery charge light will glow red when the main switch is turned on and should go out as engine starts. If the lamp continues to glow above idle speeds, the battery is being discharged, indicating the electrical system should be checked.

■ Engine Stop Knob

Pull engine stop knob rearward and hold it until the engine stops.

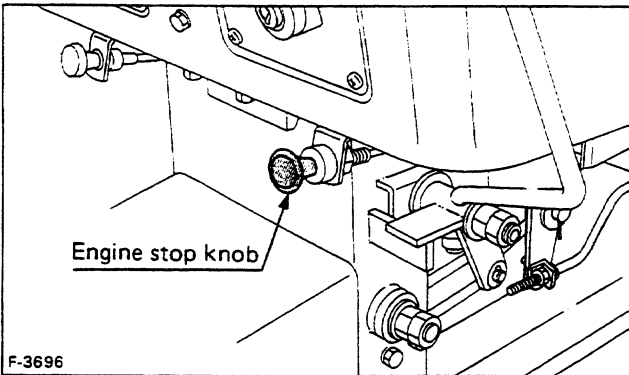

■ Throttle Lever

Pulling the throttle lever rearward decreases engine speed, and pushing it forward increases engine speed.

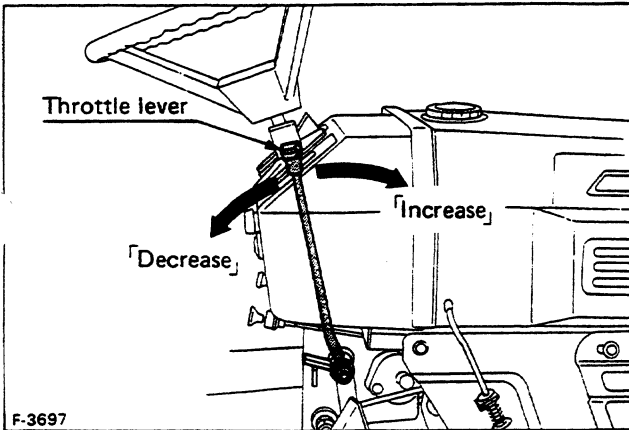

■ Speed Control Pedal

Forward Pedal

Depress the forward pedal with the toe of your right foot to move forward.

Reverse Pedal

Depress the reverse pedal with the heel of your right foot to move backward. Speed Set Device must be disengaged before depressing reverse pedal.

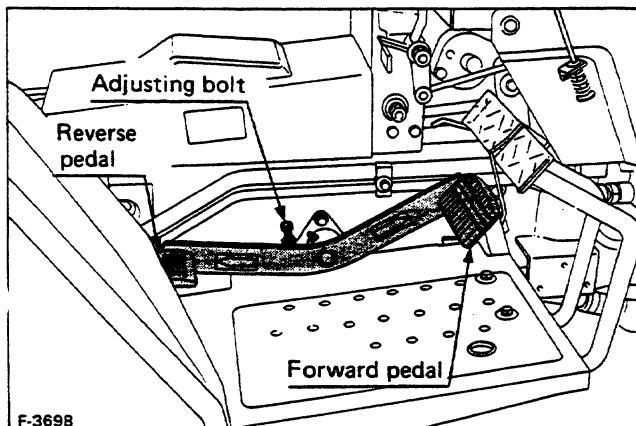

■ High-Low Gear Shift Lever

High-low gear shift lever moves in the form of "I" in 3 stages, "Low", "Neutral" and "High".

By using the speed control pedal and high-low gear shift lever, various speeds can be obtained.

IMPORTANT:

- To shift high-low gear shift lever, disengage the speed set lever and stop the tractor before attempting to proceed with speed change.

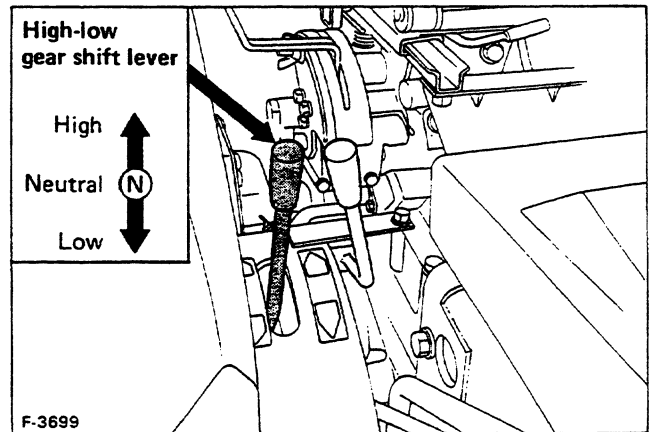

■ Speed Set Device (B7200HST: Standard B6200HST: if equipped)



CAUTION:

- Pull the speed set lever completely to the rear before starting the engine.

The Speed Set Device is designed for tractor operating efficiency and operator comfort. This device will provide a constant forward operating speed by mechanically holding the speed control pedal at the selected position.

Speed set device can not be set at high speed range.

- To engage Speed Set Device
 1. Accelerate speed to desired level using Speed Control Pedal, and move lever forward.
 2. Release Speed Control Pedal and desired speed will be maintained.
- To disengage Speed Set Device, move lever rearward.

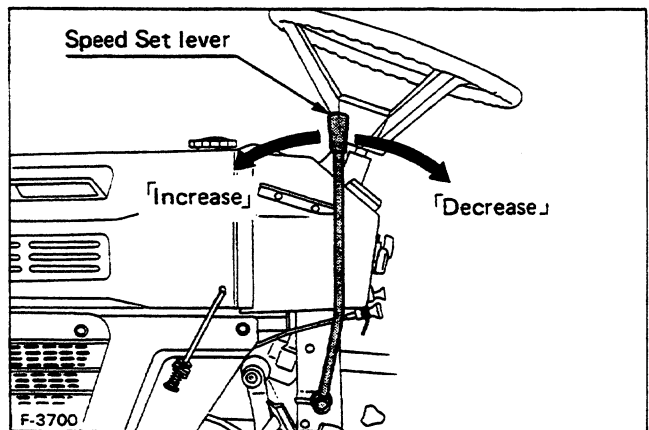

Clutch Pedal

The clutch is disengaged when the clutch pedal is fully pressed down.

IMPORTANT:

To help prevent premature clutch wear:

- (1) The clutch pedal must be quickly disengaged and be slowly engaged.
- (2) Avoid operating the tractor with your foot resting on the clutch pedal.

Front Wheel Drive Lever (4 WD)

The front wheel drive is used only when greater traction power is required or to prevent the tractor from lunging during rotary tilling hard soil.

Lowering the lever engages the front wheels for 4 wheel drive.

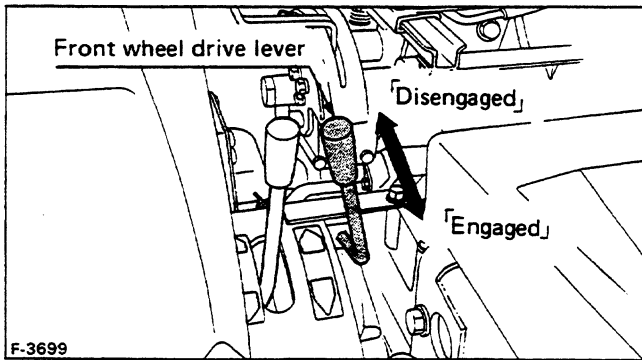

F-3699

PTO Speed Gear Shift Lever

CAUTION:



- To prevent from overspeeding a PTO driven implement and possibly causing personal injury, use the 2nd rear PTO speed (858 rpm) and mid PTO speed (1546 rpm, 2455 rpm) only when these higher rpms are specially recommended by the implement manufacturer.

The tractor has two speed selections for the rear and mid PTO.

1st	Rear— 540 RPM	2nd	Rear—858 RPM
	Mid—1546 RPM		Mid—2455 RPM

To shift into 2nd PTO speed, rotate the restrictor plate. Release the restrictor plate to the original position following use of 2nd speed position.

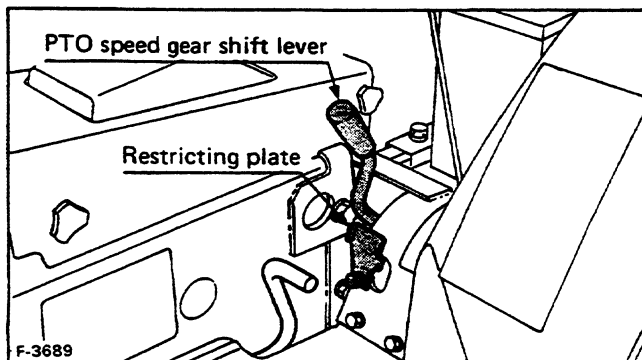

F-3689

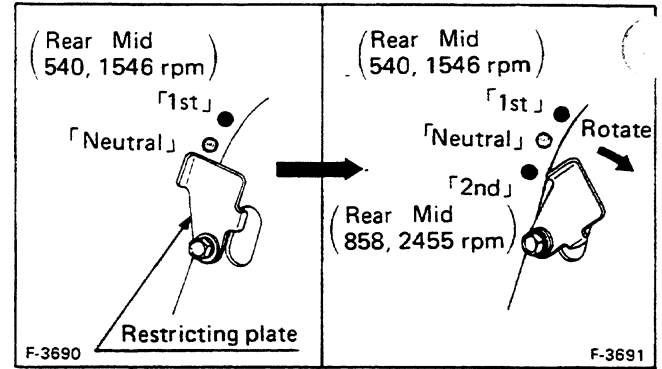

F-3690

F-3691

Mid PTO

The mid PTO is available for Kubota mid mount mower RC48-62H, RC60-72H.

Before using the mid PTO, remove the shaft cover from mid PTO case.

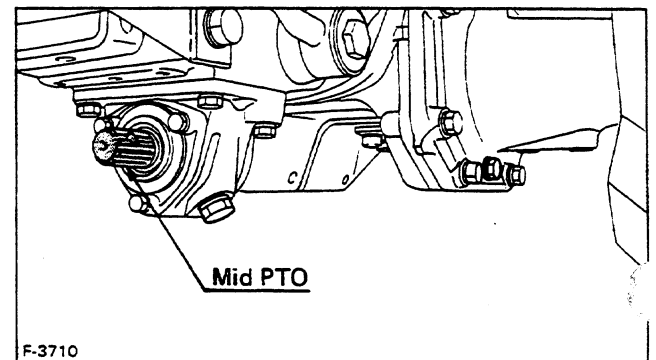

F-3710

Brake Pedals (Right and Left)



WARNING:

- Applying only one rear wheel brake at high speeds could cause the tractor to swerve or roll-over.
- (1) Before operating the tractor on a road, be sure to interlock the right and left pedals as illustrated below.
 - (2) Use individual brakes to assist in making sharp turns in field operation only.
- Disengage the brake lock and depress only one-brake pedal.

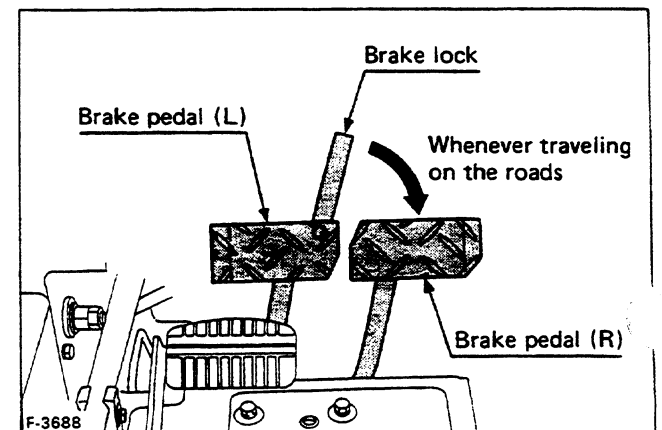

F-3688

■ Parking Brake Lever

- 1) To set the parking brake;
 - Interlock the brake pedals.
 - Depress the brake pedals.
 - Latch the brake pedals with the parking brake lever.
- (2) To release the parking brake, depress the brake pedals again.

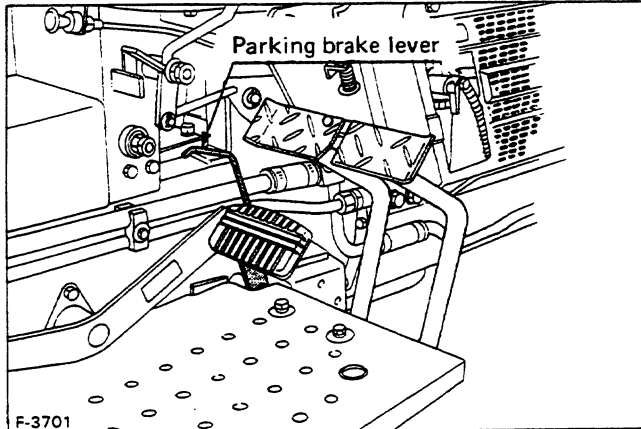

■ Differential Lock Pedal



CAUTION:

- Never apply the differential lock when traveling at high speeds. Doing so could cause the tractor to swerve out of control.

Differential lock is applied only in cases when the wheels are likely to slip, or only one of the rear wheel slips. Lightly stepping on the differential lock pedal with the heel makes the rear wheels run at equal speed. To unlock, just release the pedal.

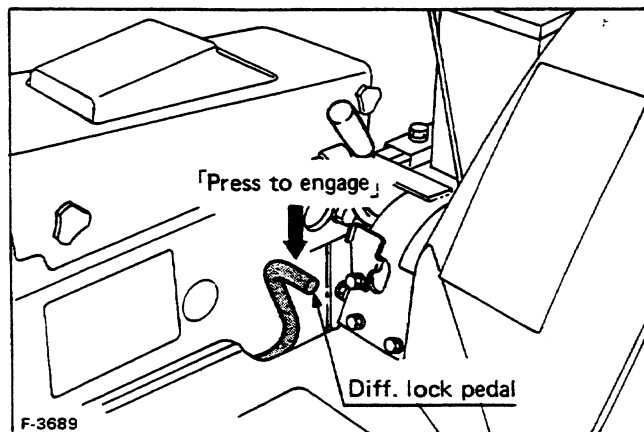

■ Adjustable Sliding Seat

The operator's seat position can be adjusted forward and backward in 100 mm (4 in.) range by pulling the seat sliding lever.

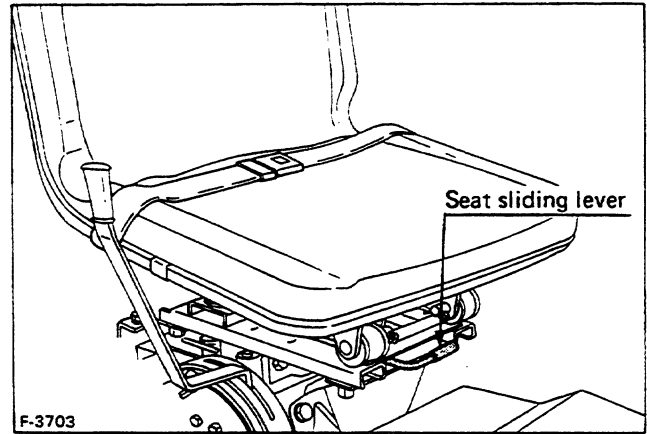

■ How to Open the Hood

To open the hood, remove the hood latches located on both sides.

Lift the hood from the rear.



CAUTION:

- Never open the hood while the engine is running.

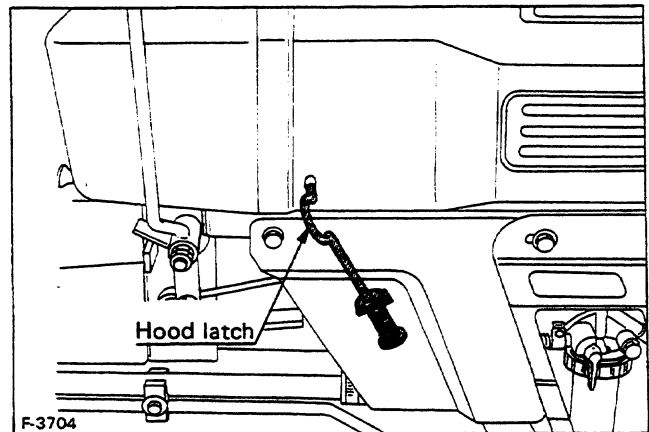

■ Hydraulic Control Lever (for 2WD)

Operating the hydraulic control lever actuates the hydraulic lift arm, which controls the elevation of 3-point hitch mounted implement.

To lower implement, push the lever forward; to raise it, pull the lever back.

IMPORTANT:

- (1) Do not operate until the engine is well warmed up. If operation is attempted while the engine is still cold, the hydraulic mechanism will not properly function and its service life will be shortened.
- (2) If noises are heard when the implement is lifting after the hydraulic control lever has been activated, the hydraulic mechanism is not adjusted properly. Unless corrected the unit will be damaged. Contact your Kubota dealer for adjustment.

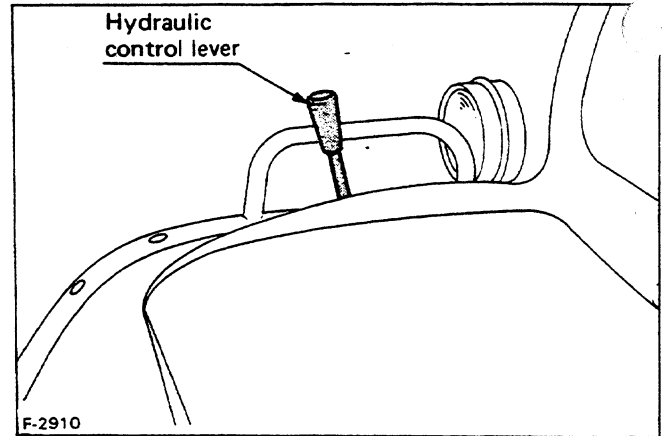

■ Position Control Lever (Standard for 4WD only)

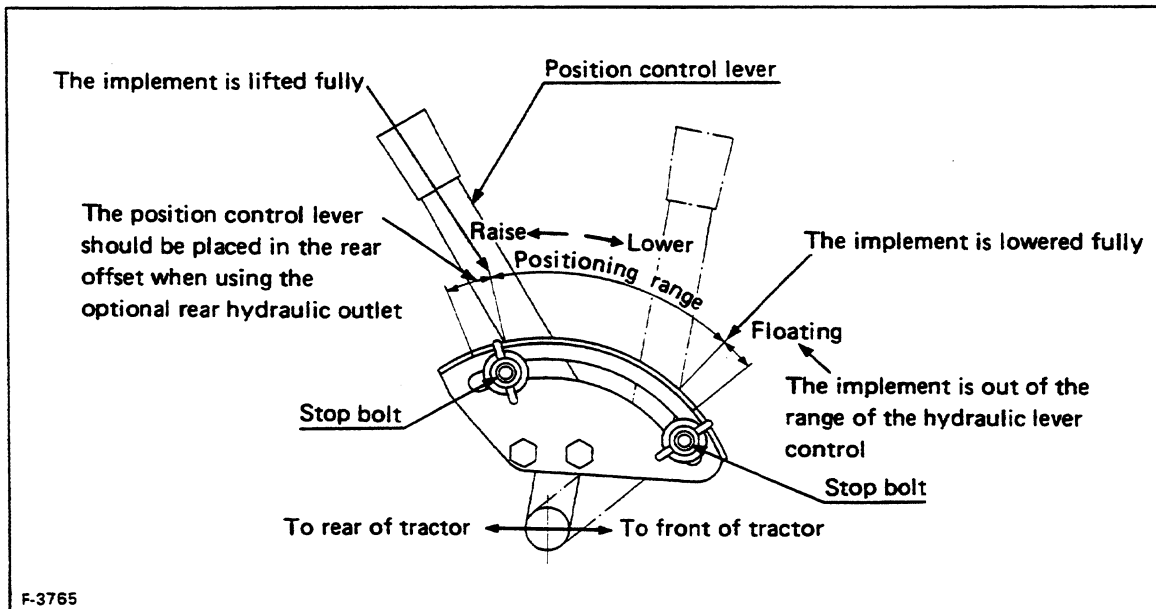

(Operation with position control)

- (1) To raise implement, pull the lever back fully. When the relief valve is activated, push the position control lever forward a little to prevent the system from operating at relief pressure.
- (2) To lower implement, push the lever forward.

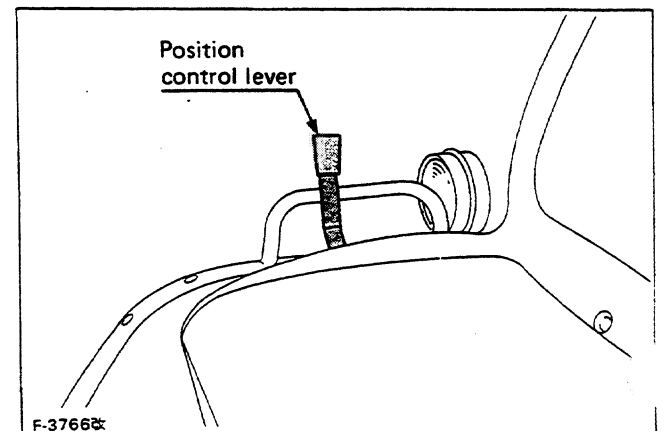

■ Implement Lowering Speed Control (for 2WD)

Adjust lowering speed of implement by turning the adjusting bolt on the hydraulic control valve.

The lowering speed depends on weight of implement and operating speed.

After loosening the lock nut, turn the adjusting bolt.

Turning it clockwise slows down the lowering speed while turning it counterclockwise accelerates the speed.

After adjustment, securely tighten the lock nut.



CAUTION:

- When transporting on the road, set the implement lowering control in the "lock" position to hold the implement in the raised position.

IMPORTANT:

- Note that the proper lowering speed of a rotary tiller is such that it takes two or three seconds to descend from the top position to the ground.

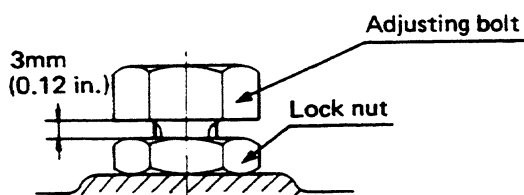
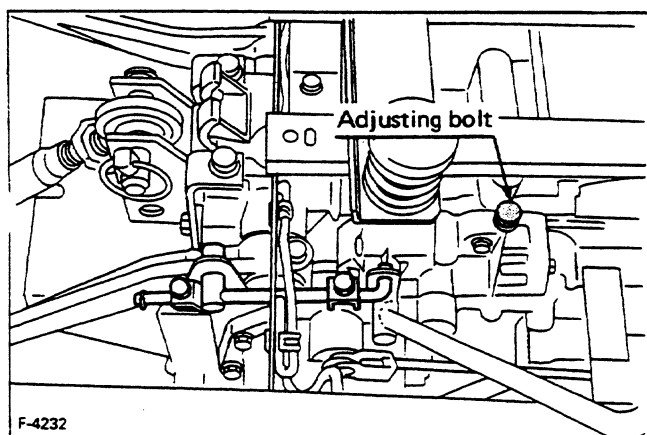

■ Implement Lowering Speed Control (for 4WD)

Adjust lowering speed of implement by turning the grip under the seat. The lowering speed depends on weight of implement and operating speed.

Adjust grips clockwise for slow lowering speed, counterclockwise for faster lowering speed.

Do not overtighten the grip.



CAUTION:

- When transporting on the road, set the implement lowering control in the "lock" position to hold the implement in the raised position.

IMPORTANT:

- Note that the proper lowering speed of a rotary tiller is such that it takes two or three seconds to descend from the top position to the ground.

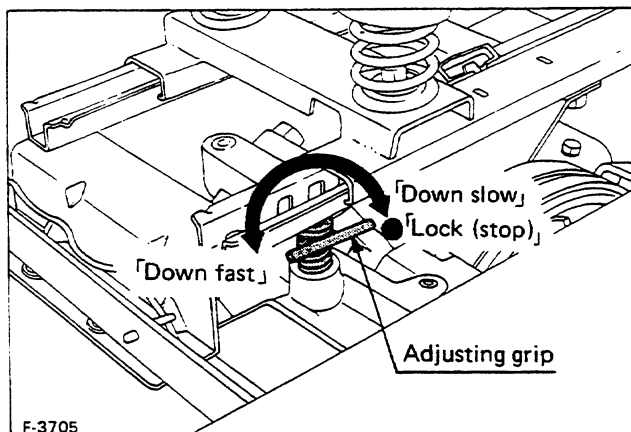

■ Implement Lifting and Lowering Limits (for 2WD)

The implement lifting and lowering limits can be changed by shifting locker A or B.

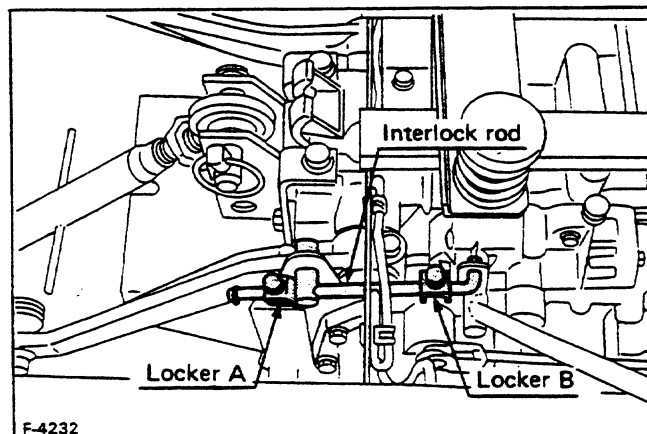

(1) Lower Limit

The lower limit can be changed by adjusting the position of locker A. Shifting the locker A rearward lowers the lower limit and shifting it forward raises the lower limit.

(2) Upper Limit

The upper limit can be changed by adjusting the position of locker B. Shifting the locker B rearward lowers the upper limit and shifting it forward raises the upper limit.

5.3 AUXILIARY HYDRAULICS



CAUTION:

- Escaping hydraulic fluid under pressure can have sufficient force to penetrate skin, causing serious personal injury. Before disconnecting lines, be sure to relieve all pressure. Before applying pressure to system, be sure all connections are tight and that lines, pipes, and hoses are not damaged. Fluid escaping from a very small hole can be almost invisible. Use a piece of cardboard or wood, rather than hands, to search for suspected leaks.

If injured by escaping fluid, see a doctor at once. Serious infection or reaction can develop if proper medical treatment is not administered immediately.

■ Hydraulic Block Type Outlet

Hydraulic block type outlet is useful when adding hydraulic operated equipment such as: front end loader, front blade, etc.

WHEN IMPLEMENT IS ATTACHED

- Remove the plugs and lock plate.
- Route the implement inlet and outlet hoses as shown in the illustration.
- Move the directional valve forward to pin ⑥ when implement is attached.

IMPORTANT:

- When an implement is not attached be sure the directional valve is turned back against pin ⑦ and the lock plate is installed.

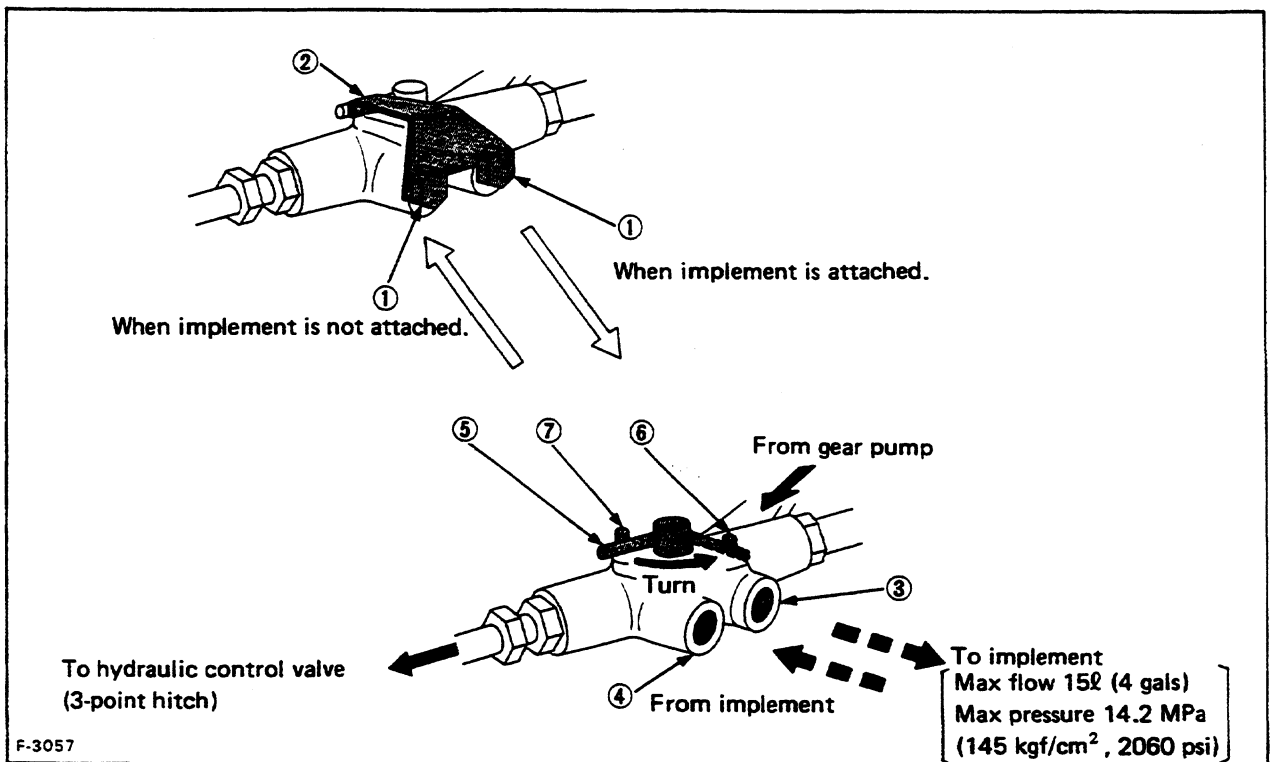

6. THREE-POINT HITCH & DRAWBAR

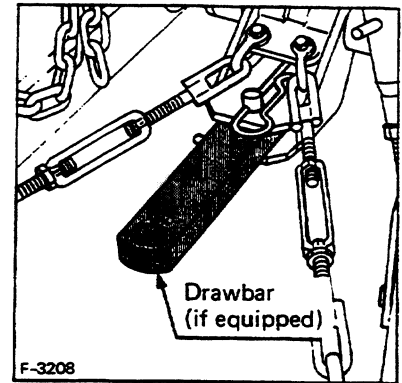
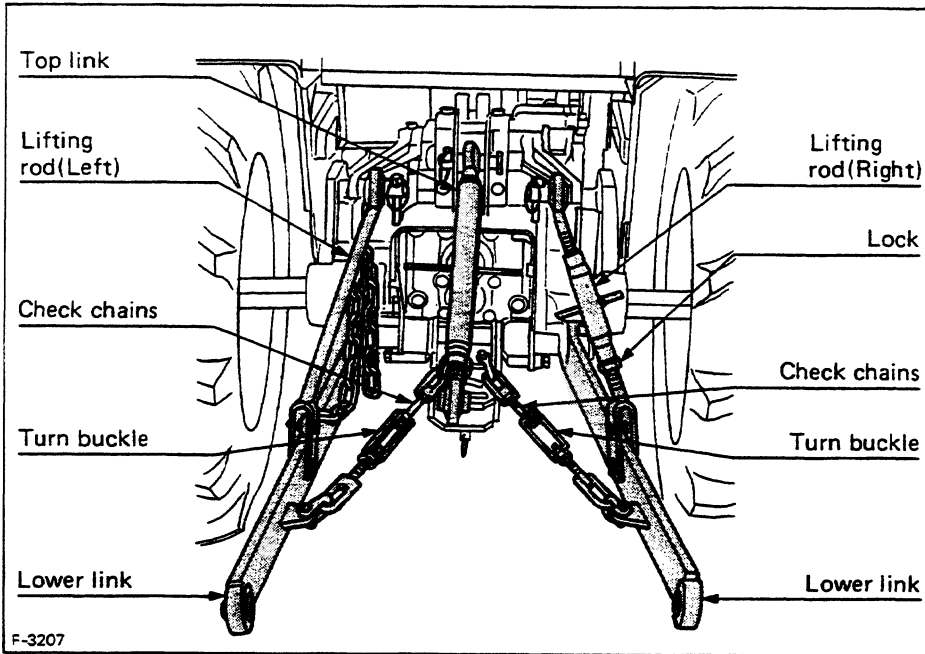

■ Adjustment of Top Link

- (1) Adjust the angle of the implement to the desired position by shortening or lengthening the Top Link.
- (2) The proper length of the top-link varies according to the type of implement being used.

■ Adjustment of Lifting Rod

- (1) Level a 3-point mounted implement from side to side by turning the lifting rod lever to shorten or lengthen the adjustable lifting rod.
- (2) After the adjustment is completed, secure with the lock.
- (3) Correct positioning of the lifting rod to the lower link is shown below. Positioning varies according to the type of implement being used.

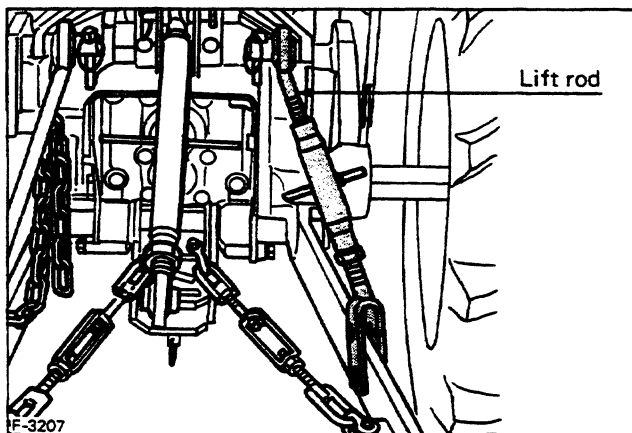

■ Adjustment of Check Chains

Adjust the turn-buckle to control horizontal sway of the implement.

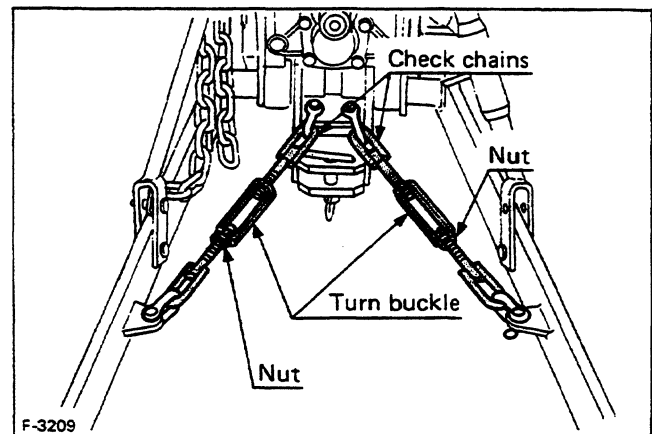

Type of implement	Chain adjustment
Plow, furrower, sub-soiler, cultivator, ditcher	Loosen until the implement can be moved 50~60 mm (2~2.5 in.) horizontally.
Rotary, mower, hayrake, tedder, ridger	Tighten

7. WHEELS, TIRES AND BALLAST



CAUTION:

Never operate tractor with a loose rim, wheel, or axle.

- (1) Any time bolts and nuts are loosened, retighten to specified torque.
- (2) Check all bolts and nuts frequently and keep them tight.
- (3) Check wheel tube pin and snap pin are securely set.

IMPORTANT:

Follow same checking procedure when tractor is first used.



CAUTION:

- (1) When working on slopes or with trailer, set the wheel tread as wide as practical for the job for maximum stability.
- (2) After the change of rear wheel tread, set wheel tube pin and snap pin securely and tighten the nut of the cotter pin to specified torque.

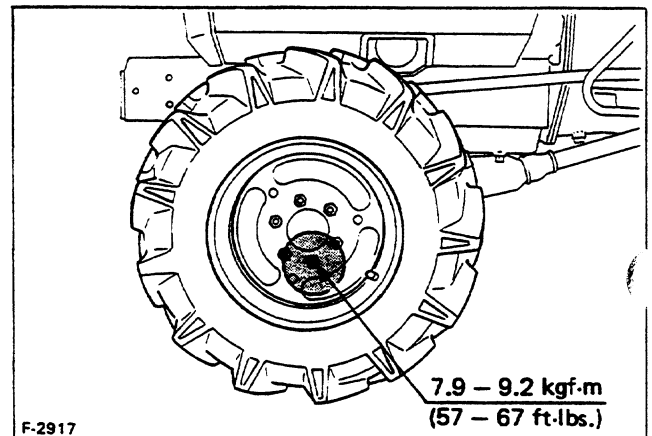
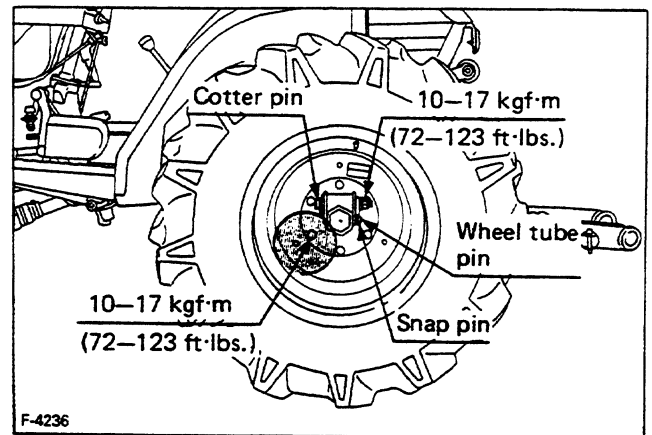

7.1 TREADS

B6200HST

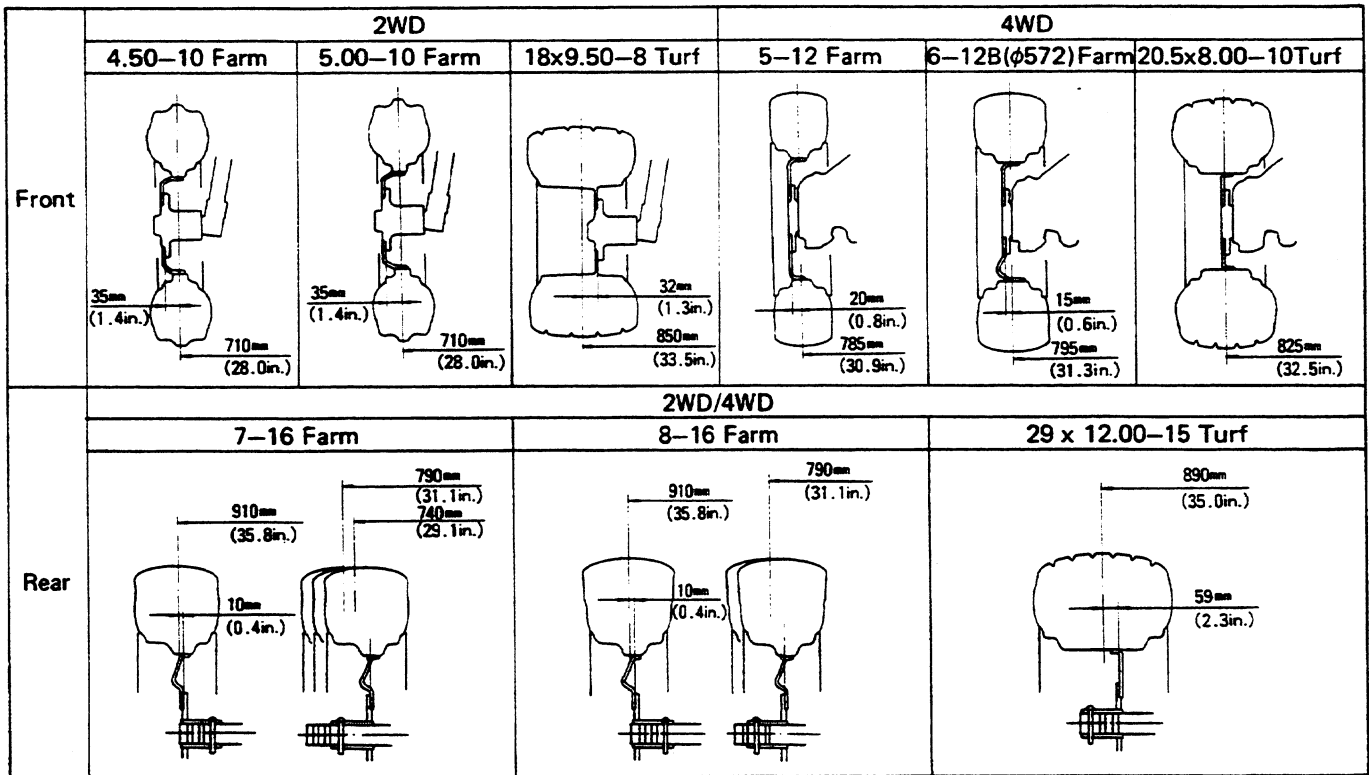

F-3058

B7200HST

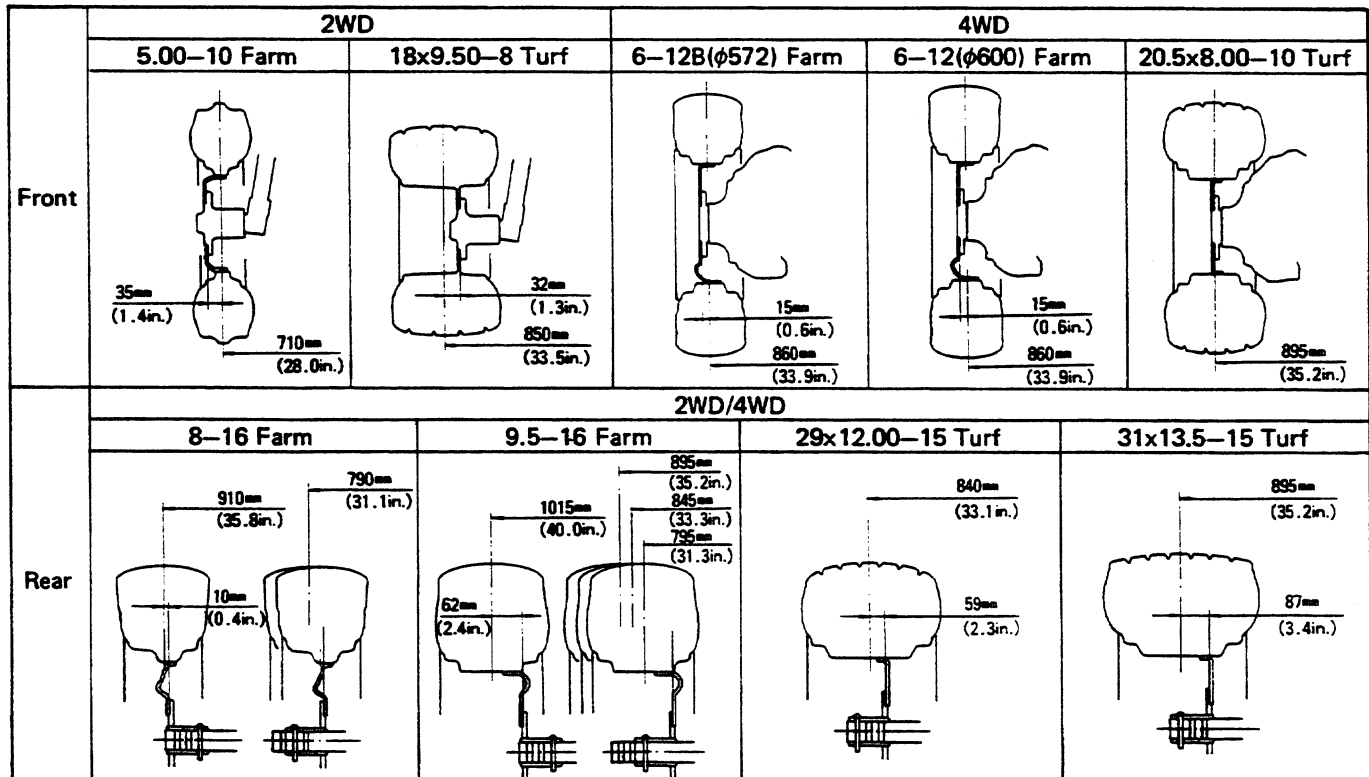

F-3059

IMPORTANT:

- (1) Always attach tires as shown in the above drawings.
- (2) If not attached as illustrated, transmission parts may be damaged.

Do not use tires larger than specified.

7.2 WHEEL HUB

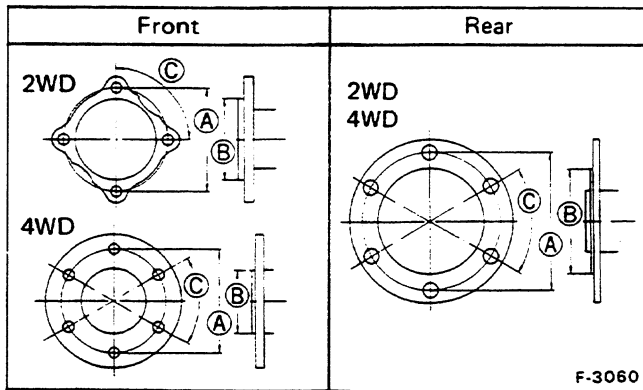

	Front wheel hub		Rear wheel hub
	2WD	4WD	2WD/4WD
Bolt circle diameter A	115 mm (4.53 in)	115 mm (4.53 in)	152 mm (6.0 in)
Number of bolts	4	6	6
Bolt specifications(mm)	M12 x Pitch 1.25	M12 x Pitch 1.25	M14 x Pitch 1.5
Pilot bore diameter B	90 mm (3.54 in)	69.5 mm (2.74 in)	114 mm (4.49 in)
Hole spacing C	Equal 90 deg.	Equal 60 deg.	Equal 60 deg.

7.3 TIRES

Though the tire pressure is factory-set to the prescribed level, it naturally drops slowly in the course of time. Thus, check it everyday and inflate as necessary.

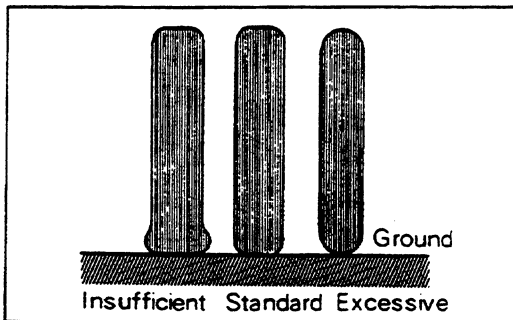

CAUTION:

- Do not attempt to mount a tire. This should be done by a qualified person with the proper equipment.

Qualified persons with the proper tire mounting equipment should recognize the following warning.



WARNING:

- Never exceed the pressure shown below (maximum limit) when attempting to seat a bead. If beads have not been seated by the time the pressure reaches maximum limit, deflate the assembly, reposition the tire on the rim, relubricate and reinflate. After seating the bead, adjust inflation pressure as recommended in the inflation pressure chart.

Maximum Limit of Inflation Pressure (In seating a bead)

Farm tire	4.50-10, 2PR	345kPa (3.5 kgf/cm ² , 50psi)
	5.00-10, 4PR	
	5-12, 4PR	
	6-12, 4PR	
	7-16, 4PR	
	8-16, 4PR	
Turf tire	9.5-16, 4PR	296kPa (3.0 kgf/cm ² , 43psi)
	18x9.50-8, 4PR	
	20.5x8.00-10, 4PR	
	29x12.00-15, 4PR	
	31x13.5-15, 4PR	

7.4 BALLAST

(1) Selecting Front Ballast

Add weight to front end if needed for stability. Heavy pulling and heavy rear mounted implements tend to lift front wheels. Add enough ballast to maintain steering control and prevent tip over. Remove weight where it is no longer needed. Front weights are available from your Kubota Dealer. Your dealer can help you decide how much is required for your particular application.



CAUTION:

- Additional ballast may be needed for transporting heavy integral implements. When implement is raised, drive slowly over rough ground, regardless of how much ballast is used.

(2) Select rear ballast carefully.

Add weight to rear wheels if needed to improve traction or for stability. Amount of rear ballast should be matched to job and ballast should be removed when it is not needed. Rear wheel weights are available or liquid may be added to the tires. Consult your Kubota Dealer for the correct ballasting necessary for your particular application.

(2-1) Using liquid weight in rear tires.

Water and calcium chloride solution provides, safe economical ballast. Used properly, it will not damage tires, tubes or rims. The addition of calcium chloride is recommended to prevent the water from freezing. Use of this method of weighting the wheels has the full approval of the tire companies. See your tire dealer for this service. Do not fill any tire more than 75% full (to valve stem level).

Liquid weight per tire (75 Percent filled)

Tire sizes	7-16	8-16	9.5-16
Slush free at -10°C (13°F) Solid at -30°C (-23°F) [Approx. 1 kg (2 lbs.) CaCl ₂ per 4ℓ (1 gal) of water]	26 kg (58 lbs.)	35 kg (78 lbs.)	54 kg (119 lbs.)
Slush free at -24°C (-12°F) Solid at -47°C (-52°F) [Approx. 1.5 kg (3.5 lbs.) CaCl ₂ per 4ℓ (1 gal) of water]	28 kg (61 lbs.)	37 kg (82 lbs.)	57 kg (125 lbs.)
Slush free at -47°C (-52°F) Solid at -52°C (-62°F) [Approx. 2.25 kg (5 lbs.) CaCl ₂ per 4ℓ (1 gal) of water]	29 kg (64 lbs.)	39 kg (86 lbs.)	60 kg (132 lbs.)

IMPORTANT:

- Do not fill the following tires with water.
4.50-10 5-12 18x9.50-8 29x12.00-15
5.00-10 6-12 20.5x8.00-10 31x13.5-15

Inflation Pressure

Front	4.50-10, 4PR	140kPa (1.4kgf/cm ² , 20psi)
	5.00-10, 4PR	270kPa (2.8kgf/cm ² , 40psi)
	5-12, 4PR	220kPa (2.2kgf/cm ² , 31psi)
	6-12, 4PR	200kPa (2.0kgf/cm ² , 28psi)
	18x9.50-8, 4PR	140kPa (1.4kgf/cm ² , 20psi)
Rear	20.5x8.00-10, 4PR	160kPa (1.6kgf/cm ² , 23psi)
	7-16, 4PR	180kPa (1.8kgf/cm ² , 26psi)
	8-16, 4PR	160kPa (1.6kgf/cm ² , 23psi)
	9.5-16, 4PR	140kPa (1.4kgf/cm ² , 20psi)
	29x12.00-15, 4PR	140kPa (1.4kgf/cm ² , 20psi)
	31x13.5-15, 4PR	140kPa (1.4kgf/cm ² , 20psi)

7.5 TOE-IN

Toe-in equals distances (C)(D)–(A)(B), or 0 to 5 mm (0 to 0.2 in.).

To adjust toe-in loosen the lock nut and adjust the length of the tie rod until the proper toe-in measurement is obtained. Retighten the lock nut.

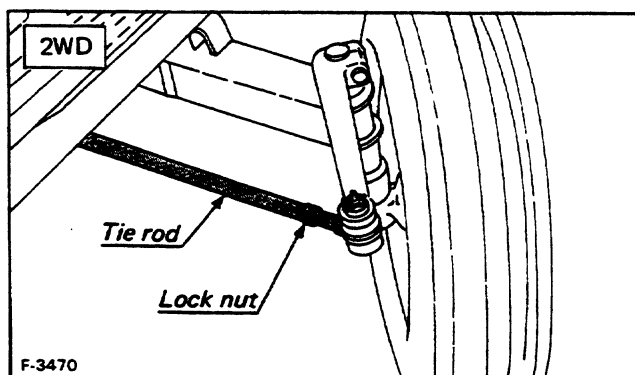
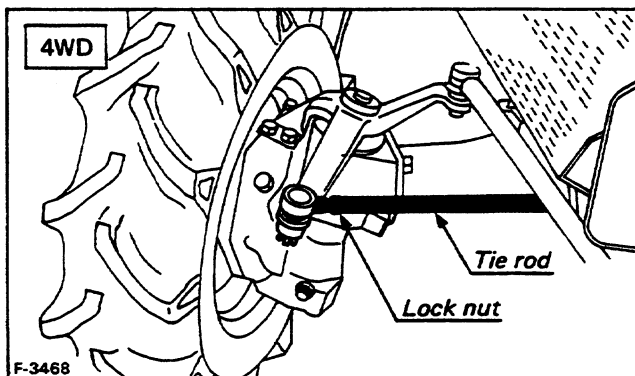
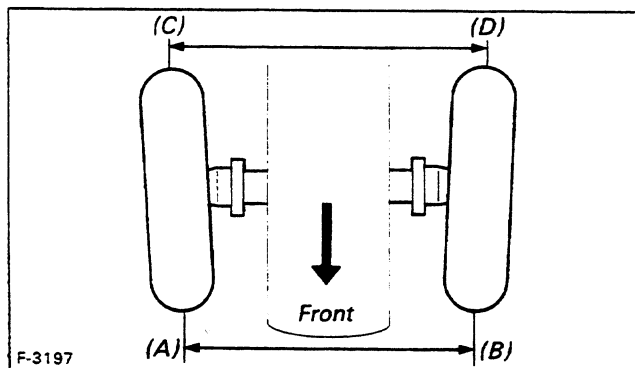

8. OPERATING INSTRUCTIONS

Pre-Start Checks

Prior to starting the engine, make pre-start checks according to the Maintenance Check List on page 30 to 31.



CAUTION:

- (1) Read "For Safe Operation" in the front of this manual.
- (2) Read the Warning and Caution labels located on the tractor.

8.1 OPERATING THE ENGINE



CAUTION:

- (1) To avoid the danger of exhaust fume poisoning, do not operate the engine in a closed building without proper ventilation.
- (2) Make it a rule to pull the speed control lever completely to the rear and to set high-low gear shift lever and PTO gear shift lever to the "neutral" positions before starting the engine.

■ Starting

- (1) Sit in the operator's seat. If the tractor is equipped with a ROPS, fasten the seat belt.
- (2) Set the parking brake.
- (3) Pull speed control lever completely to the rear and place high-low gear shift lever and PTO speed gear shift lever in the "neutral" positions.
- (4) Place hydraulic control lever in lowest position.
- (5) Push in the engine stop knob.
- (6) Insert the key into the key switch and turn it on.
- (7) Make sure that the engine oil pressure lamp is on.
- (8) Fully depress the clutch pedal and turn the key switch left, until the glow plug lamp turns red. Though the glow plug lamp turns red in about 10 seconds, it takes at least 20 seconds until the preheating coil in the combustion chamber is fully heated. The lower the ambient temperature, the longer the preheating time. For the necessary preheating time, refer to the table below:

Temperature	Preheating Time
Over 0°C (32°F)	20 – 30 sec.
0 to -5°C (32 to 23°F)	40 – 60 sec.

- (9) Turn the key switch to the start position and the starter will turn and the engine should start.
- (10) Make sure that the engine oil pressure lamp has gone off. If the lamp is still on, immediately stop the engine and check the lubrication system.
- (11) Perform warm-up operations by running the engine at the medium speed.

IMPORTANT:

- (1) Do not turn the key switch, while the engine is running.
- (2) When the temperature is below 0°C (32°F), place the high-low gear shift lever in the neutral position and keep the engine at medium speed to warm up the lubricant of engine and transmission at least 10 minutes.
If the tractor is operated before the lubricant of engine and transmission is warmed sufficiently, the tractor life will be shortened.
- (3) Do not operate the tractor under full load condition until it is sufficiently warmed up.
- (4) Do not use starting fluid.

■ Starting with Weak Battery or in Cold Weather

Perform the following procedure between the steps (6) and (10) on Starting:

- (1) Pull out the decompression knob.
- (2) Depress the clutch pedal all the way and turn the key switch to the start position.
- (3) After the flywheel starts to run at full speed in 3 to 5 seconds, push the decompression knob back. If necessary, operate preheating before drawing the decompression knob.

IMPORTANT:

- When the ambient temperature is less than -15°C (5°F), remove the battery from the tractor and store in a warm place until next operation.

■ Stopping

- (1) Pull the engine stop knob completely and hold it until the engine stops.
- (2) Turn the key switch off and pull the key out of the switch.

IMPORTANT:

- Although engine can be stopped by pulling out the decompression knob, this should not be done except in such an emergency case that the engine cannot be stopped by pulling the engine stop knob. Especially, if the decompression knob is pulled out while the engine is running at high speed, there is the danger that the valve seat may be damaged or that the decompression device may malfunction.

8.2 OPERATING THE TRACTOR

■ Starting

- (1) Depress the clutch pedal to disengage the clutch.
- (2) Shift the high-low gear shift lever to the desired speed position.
- (3) Unlock the parking brake.
- (4) Speed up the engine by moving the throttle lever forward.
- (5) Slowly release the clutch pedal.
- (6) Depress the forward pedal with the toe of your right foot to move forward.
- (7) Depress the reverse pedal with the heel of your right foot to move backward.



[CAUTION]

- (1) Interlock the right and left brake pedals before starting. Uneven braking results in a sharp turn, which may even turn over the tractor.
- (2) Do not allow any person other than the driver to ride on the tractor.
- (3) Do not drive the tractor close to the edges of ditches or banks which may break under the weight of the tractor, especially when the ground is loose or wet.
- (4) When turning the tractor, be sure to slow down the traveling speed by speed control pedal.
- (5) Do not drive the tractor on the road with the implement in motion.
- (6) After the differential lock has been used, be sure to see that it has been released.
- (7) When traveling on a road, attach the S.M.V. emblem to the tractor to identify itself to be a low speed vehicle. (Option)

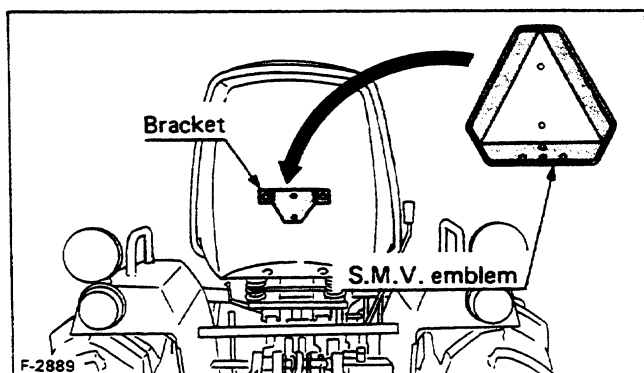

[IMPORTANT]

- (1) Do not move the tractor with the parking brake on.
- (2) Do not operate the tractor with your foot resting on the clutch pedal. This may contribute to premature clutch wear.
- (3) High-Low gear shift lever cannot be shifted during driving. To do this, be sure to stop the tractors.

■ Stopping

- (1) Slow down the engine.
- (2) Interlock the right and left brake pedals and put on the parking brake.

■ Parking

- (1) When parking, be sure to engage the parking brake.
- (2) If necessary to park on an incline, be sure to chock the wheels to prevent accidental rolling of the machine.

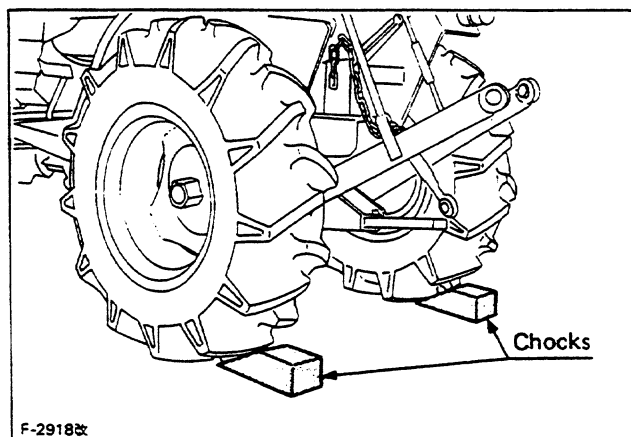

- (3) Before getting off the tractor, be sure to stop the engine and lower the implement to the ground.

8.3 PULLING



CAUTION:

- Never pull from the top link, the rear axle or any point above the drawbar. Doing so could cause the tractor to tip over rearward causing personal injury.

For pulling, attach to the drawbar. Use the 3-point hitch only with equipment designed for 3-point hitch usage.

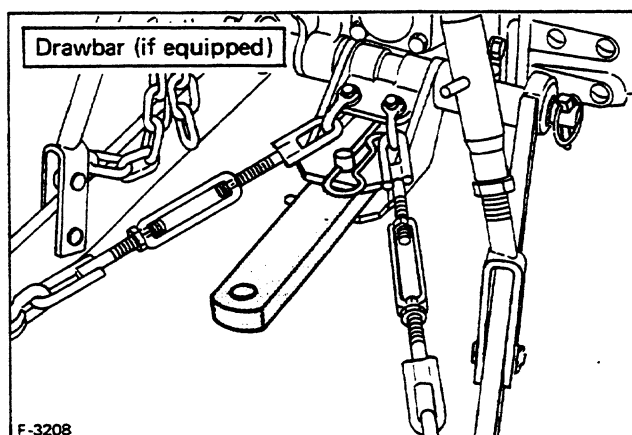

8.4 CHECK DURING DRIVING

While driving, make the following checks to see that all the parts are functioning normally.

■ Coolant



CAUTION:

- Do not remove radiator filler cap until coolant temperature is below its boiling point. Then loosen cap slightly to the stop to relieve any excess pressure before removing cap completely.

If the temperature of the coolant rises above 100°C (212°F), immediately stop the engine and determine the cause, with the safety caution in mind.

- (1) Shortage or leakage of the coolant.
- (2) Foreign matter on the radiator net and dust and dirt between the radiator fins and tube.
- (3) Loose fan drive belt.
- (4) Blockage in the radiator tube.

■ Engine Oil Pressure Light

The pressure light signals to the operator that the engine oil pressure is below the prescribed level. If the light should go on during operation, immediately stop the engine and check;

- (1) The level of the engine oil. (See page 33)
- (2) The conditions of the lubrication system.

■ Battery Charge Light

The charge light signals to the operator that alternator is not charging the battery.

If the light goes on during operation, immediately stop the engine and check:

- (1) Wiring failure.
- (2) Connection failure of alternator and regulator.
- (3) Alternator drive belt failure.

■ Fuel

Do not allow the fuel tank to empty completely.

Doing so will allow air to enter into the fuel system. Should this happen, the fuel system must be bled. (See page 32)

■ Exhaust Fumes

- (1) Exhaust fumes are colorless at normal output drive.
- (2) If the exhaust turns dark continuously during driving, this probably indicates an overburden on the engine. In such a case, corrective action should be applied to conditions of operation so that subsequent damage to the engine can be avoided.

■ Urgent Stop

Should the following abnormally take place, immediately stop the engine.

- (1) The engine suddenly slows down or speeds up.
 - (2) Unusual noises are suddenly heard.
 - (3) Exhaust fumes suddenly become very dark.
 - (4) The engine oil pressure light illuminates while operating.
 - (5) The battery charge light illuminates while operating.
- For checks and remedies in the above situations, consult your dealer.

8.5 DIRECTIONS FOR OPERATING

■ Differential Lock Pedal

Observe the following precautions when applying the differential lock.

- (1) Apply the differential lock moderately. Limit its use to the below situations.
 - When the tractor enters or leaves the farm field, it cannot move straight because of excessive individual wheel-spin under difficult or slippery field conditions.
 - One rear wheel is caught in a loose area of the field and the tractor cannot move due to wheel-spin.
 - In the case of plowing, the rear wheel closer to the ridge is caught in the loose soil and is affected wheel-spin.
- (2) The use of the differential lock must be limited to a particular period of time and should not be applied continuously.
- (3) When the rear wheel is subjected to excessive loads, even releasing the pedal sometimes may not unlock the differential although the pedal springs back. Should the differential not unlock when turning the tractor, lightly step on the brake pedal opposite to the turn side or turn back the steering wheel and run the tractor straight. By doing so, the differential can be unlocked. If the brake pedal of the turn side is depressed during turning the differential lock system takes on an undue load. Avoid such improper operation.



CAUTION:

- The tractor cannot turn with the differential locked and attempting to could be very dangerous.

9. MAINTENANCE

9.1 DAILY CHECK

To prevent trouble from occurring, it is important to know the conditions of the tractor well. Check it before starting.



CAUTION:

- Be sure to check and service the tractor on a flat place with the engine shut off and the parking brake on.

- (1) Check areas where previous trouble was experienced.
- (2) Walking around the tractor;
 - 1) Check the tire pressure, and check for wear and damage. (See page 25)
 - 2) Check for oil and water leaks.
 - 3) Check the engine oil level.
(See page 33)
 - 4) Check the amount of transmission oil.
(See page 34)
 - 5) Check if there is enough fuel. (See page 32)

- 6) Check if there is enough coolant in the radiator.
(See page 37)
- 7) Check for dust in the air cleaner dust cup.
(See page 40)
- 8) Check the tractor body for damage and check that all bolts and nuts are tight.
- 9) Check the S.M.V. emblem for damage and clean or replace as necessary.
- (3) While sitting in the operator's seat;
 - 1) Check the throttle pedal, brake pedals and clutch pedal. (See page 42)
 - 2) Check the parking brake.
 - 3) Check the steering wheel. (See page 42)
- (4) Turning the key switch on;
 - 1) Check the performance of the pilot lamps.
 - 2) Check headlights, tail lights and hazard lamps, clean if necessary.
- (5) Starting the engine;
 - 1) Check the color of the exhaust fumes.

9.2 LUBRICANTS

To prevent serious damage to hydraulic systems, use only genuine Kubota fluid or its equivalent.

Place	Capacity	Lubricants
Engine crankcase	3.1 ℓ (3.3 U.S.qts.)	<ul style="list-style-type: none"> • Engine oil: API Service CC or CD Below 0°C (32°F) SAE10W or 10W-30 0 to 25°C (32 to 77°F) SAE20 or 10W-30 Above 25°C (77°F) SAE30 or 10W-30
Transmission	13.5 ℓ (14.3 U.S.qts.)	See page 47.
Front axle differential case (4WD)	B6200HST: 0.5ℓ (0.5 U.S.qt.) B7200HST: 1.5ℓ (1.6 U.S.qts.)	<ul style="list-style-type: none"> • Gear oil SAE80 or SAE90
Front axle gear case (Right & left) (4WD)	B6200HST: 0.15ℓ (0.15 U.S.qt.) B7200HST: 0.5ℓ (0.5 U.S.qt.)	<ul style="list-style-type: none"> • Gear oil SAE80 or SAE90
Steering gear box (Manual steering)	0.2 ℓ (0.2 U.S.qt.)	<ul style="list-style-type: none"> • Gear oil SAE80 or SAE90
King pins (2WD) Center pin (2WD) Brake pedal shaft Clutch release hub Seat adjuster Speed control pedal shaft	moderate amount	<ul style="list-style-type: none"> • SAE multi-purpose type grease

9.3 MAINTENANCE CHECK LIST

Frequency of Checks	Check Points	Reference Pages
Initial operation (initial 60 hours)	During this period, pay special attention to the following. (1) After the initial 35 hours of use, change the engine oil and oil filter.	33 to 34
	(2) After the initial 50 hours of use, change the transmission fluid and the oil filter cartridge and clean the transmission strainer.	34 to 35
	(3) Quick starts or sudden braking should be avoided	—
Every 75 hours	Change engine oil.	34
Every 100 hours	Lubricate the following points. King pins, Brake pedal shaft, Center pin, Speed control pedal shaft.	36
	Check the following points to be connected securely. Hydraulic inlet line clamps, Fuel line clamps	32
	Clean air cleaner element.	40
	Clean fuel filter.	33
	Check battery electrolyte level.	40
	Check fuel line.	32
	Check fan drive belt tension.	42
	Check clutch play.	42
	Check brake play.	42
Check steering wheel play.	42	
Every 150 hours	Change engine oil filter cartridge.	34
	Check radiator hose.	38
Every 200 hours	Change transmission oil filter cartridge.	35
Every 300 hours	Change transmission fluid. Transmission case, front axle differential case (4WD), front axle gear case (right and left) (4WD). • Clean transmission strainer.	34 to 36
Every 400 hours	Change fuel filter.	—
Every 500 hours	Flush radiator.	38
Every one to two months	Recharge battery if necessary.	40
Every 3 months	Change scale inhibitor and coolant.	37 to 39
Every year or every 6 times of cleaning	Change air cleaner element.	40
Every year	Change anti-freeze and coolant.	38
2 years after purchase	Change battery, if necessary.	—
	Change radiator hose and clamps, if necessary.	38
	Change fuel line and clamps, if necessary.	32 to 33
	Change hydraulic hoses and clamps, if necessary.	—

10. CHECK AND MAINTENANCE

10.1 FUEL

■ Checking and Refueling



CAUTION:

- Stop the engine before adding fuel. Keep away from sparks and flames.
- Allow engine to cool before refueling.

- (1) Add fuel before the fuel gauge reaches empty.

Fuel tank capacity	20 ℓ (5.3 U.S. gals.)
--------------------	-----------------------

- (2) Use No. 2 diesel fuel
- (3) Use No. 1 diesel fuel if temperature is below -10°C (15°F).

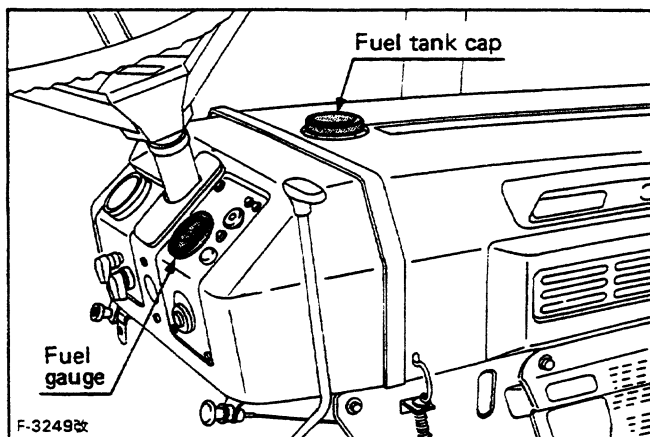

IMPORTANT:

- (1) Always use a strainer in refueling to prevent fuel injection pump contamination.
- (2) Once the fuel tank becomes empty, air is admitted to the fuel system. In such case, it will be necessary to bleed the fuel system before the engine will start.

■ Bleeding the Fuel Line

Air must be removed:

- (1) When the fuel filter and lines are removed.
- (2) When tank is completely empty.
- (3) When the tractor has not been used for a long period of time.

Bleeding procedure is as follows:



CAUTION:

- Do not bleed the fuel system when the engine is hot.

- (1) Fill the fuel tank with fuel, and open the fuel cock.

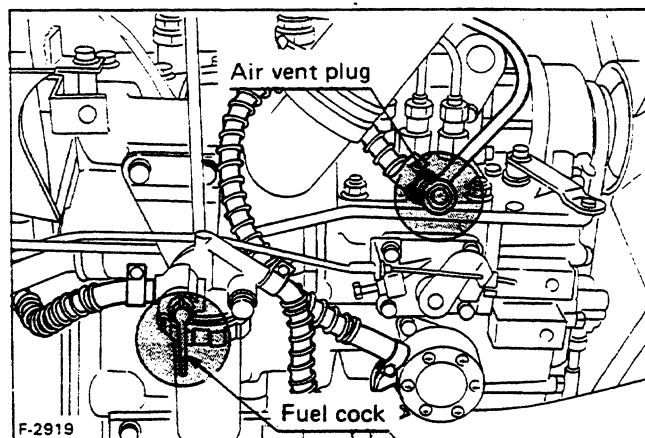

- (2) Open the air vent plug on the fuel injection pump.
- (3) Pull the engine stop knob back completely to prevent the engine from starting while turning the key to rotate the engine for about 10 seconds.



CAUTION:

- For the above procedure, pull out the engine stop knob before engaging the starter.

- (4) Close the air vent plug.

■ Checking Fuel Line



CAUTIONS:

- (1) Stop the engine when attempting to check and change as prescribed below.
- (2) Never fail to check the fuel line periodically.
The fuel line is subject to wear and aging, fuel may leak out onto the running engine, causing a fire.

Check the fuel line connections every 100 service hours or every 6 months, whichever occurs first.

- (1) If the clamp is loose, apply a slight coat of lubricant onto the threads and securely retighten it.

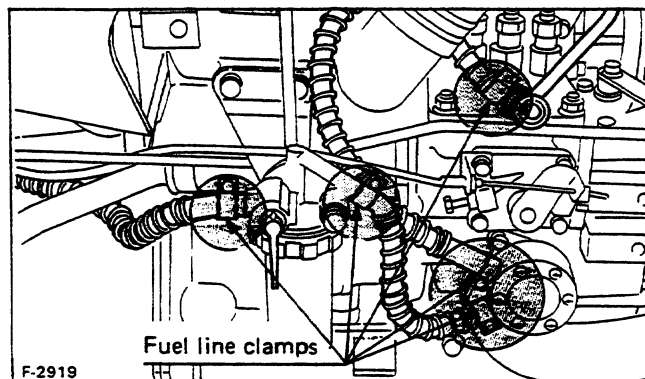

- (2) The fuel line is made of rubber and ages regardless of period of service. Change the fuel line together with the clamp whenever worn and securely tighten.
- (3) After the fuel line and clamp have been changed, bleed the fuel system.

IMPORTANT:

- When the fuel line is disconnected for change, close both ends of the fuel line with a piece of clean cloth or paper to prevent dust and dirt from entering. Entrance of dust and dirt causes malfunction of the fuel injection pump. In addition, particular care must be taken not to admit dust and dirt into the fuel pump.

■ Cleaning the Fuel Filter Bowl

When period of operation reaches approx. 100 hours, clean the fuel filter.

This job should not be done in the field, but in a clean place so as to prevent dust intrusion.

- (1) Unscrew the 5 bolts which fasten the cover RH, and remove the cover RH.

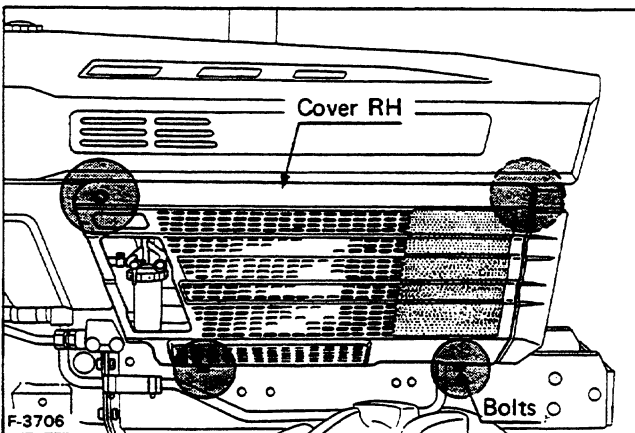

- (2) Close the fuel filter bowl cock.

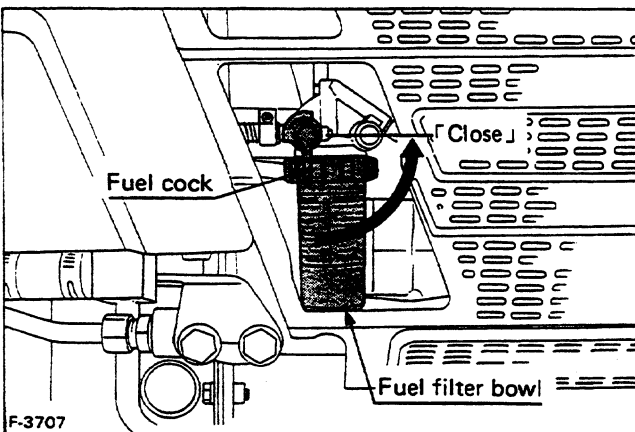

- (3) Unscrew and remove the screw ring, and rinse the inside with kerosene.
- (4) Take out the element and dip it in the kerosene to rinse.

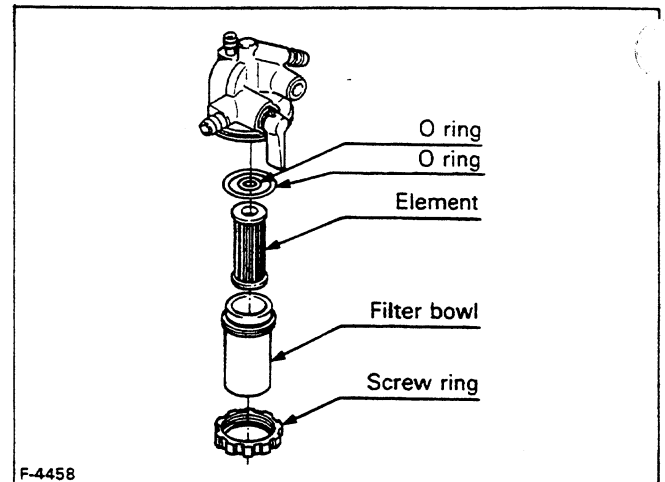

- (5) After cleaning, reassemble the fuel filter, keeping out dust and dirt.
- (6) Bleed the injection pump.

IMPORTANT:

- If dust and dirt enter the fuel, the fuel pump and injection nozzle are subject to quick wear. To prevent this, be sure to clean the fuel filter bowl periodically.

10.2 ENGINE OIL

■ Oil Level Check and Replenishment (See page 3)

- (1) Check engine oil before starting the engine and 5 minutes or more after the engine has stopped.
- (2) To check the oil level, draw out the dipstick, wipe it clean, replace it, and draw it out again. Check to see that the oil level lies between the two notches.
- (3) If the level is too low, add new oil to the prescribed level at the oil port.

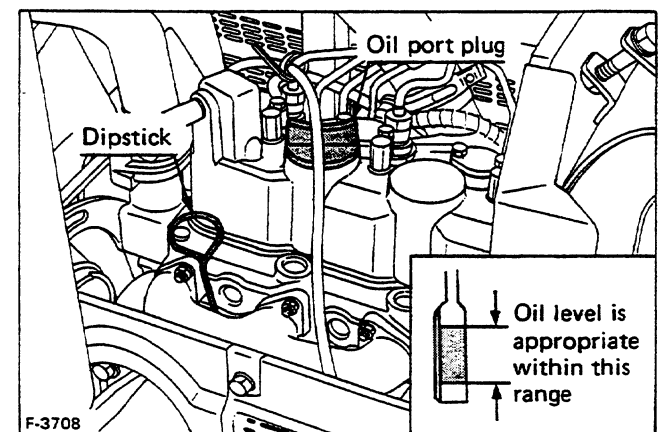

- (4) When using an oil of different brand or viscosity from the previous one, remove all of the old oil. Never mix two different types of oil.
- (5) Use the proper SAE Engine Oil according to the ambient temperatures.
Refer to 9.2 "LUBRICANTS."

■ Engine Oil Change



CAUTION:

- Before changing the oil, be sure to stop the engine.

- (1) To change the used oil, remove the drain plug at the bottom of the engine and drain the oil completely. All the used oil can be drained out easily when the engine is still warm.

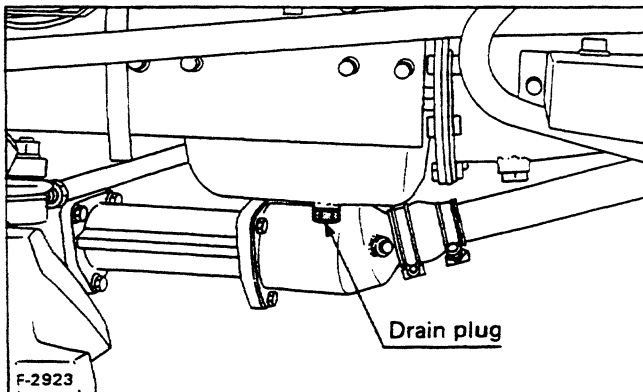

- (2) Reinstall the drain plug.
- (3) Fill with the new oil up to the upper notch on the dipstick.

■ Engine Oil Filter Cartridge Change



CAUTION:

- Be sure to stop the engine before changing the oil filter cartridge.

- (1) The oil filter cartridge must be changed every 150 service hours.
- (2) Apply a slight coat of oil onto the cartridge gasket.
- (3) To install the new cartridge, screw it in by hand. Over tightening may cause deformation of rubber gasket.
- (4) After the new cartridge has been replaced, the engine oil normally decreases a little. Thus see that the engine oil does not leak through the seal and be sure to read the oil level on the dipstick. Then, replenish the engine oil up to the prescribed level.

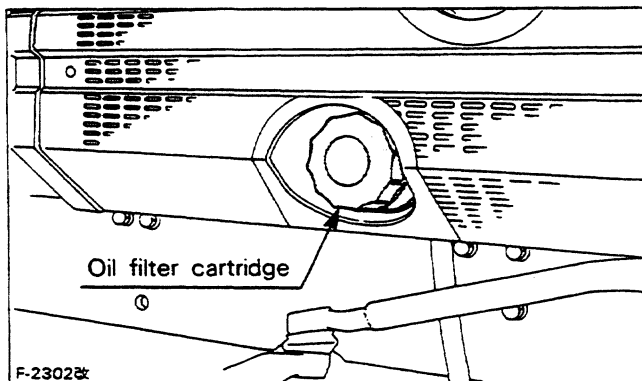

IMPORTANT:

- To prevent serious damage to the engine, replacement element must be highly efficient. Use only a genuine Kubota filter or its equivalent.

10.3 TRANSMISSION FLUID



CAUTION:

- Be sure to stop the engine before checking and changing the transmission fluid.

■ Transmission Fluid Check and Replenishment

To check the oil level, draw out the dipstick, wipe it clean, replace it, and draw out it again. Check to see that the oil level lies between the two notches.

If low, replenish through the port.

Use multi-grade transmission fluid. (See page 30)

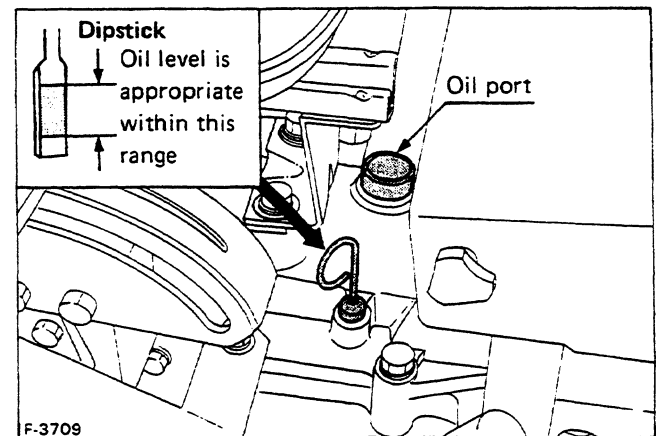

■ Transmission Fluid Change

The fluid in the transmission case is also used for the hydraulic system.

To drain the transmission case, place an oil pan underneath the transmission case and remove the drain plug at the bottom of the transmission case.

After draining, disassemble and clean the strainers and change the oil filter cartridge. After reassembling, fill with new hydrostatic transmission fluid.

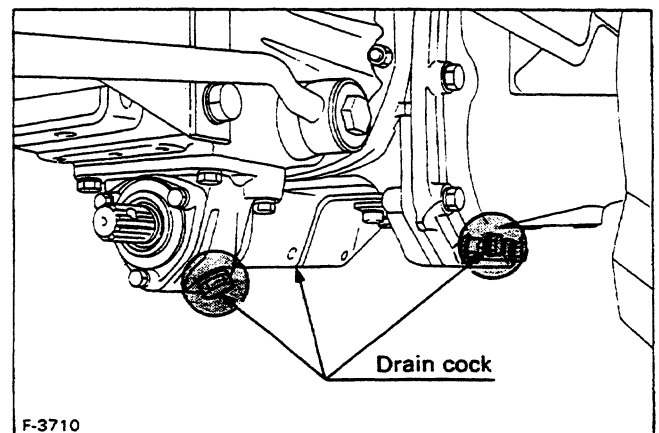

IMPORTANT:

- Never operate the tractor immediately after changing the transmission fluid and filter cartridge. Keeping the engine at medium speed for a few minutes prevents damage to the transmission.

■ Transmission Oil Filter Cartridge Change



[CAUTION]

- Be sure to stop the engine before changing the oil filters.

- (1) The oil filter cartridge must be changed every 200 service hours.
- (2) Remove the 4 bolts which secure the cover.
- (3) Remove the oil filter cartridge by using the filter wrench.
- (4) Lightly tighten the screw (A) by using a screwdriver.
- (5) Apply a slight coat of oil onto the cartridge gasket.
- (6) To install the new cartridge, screw it in by hand. Over tightening may cause deformation of rubber gasket.
- (7) After the new cartridge has been replaced, the transmission fluid level will normally decrease slightly. Make sure that the transmission fluid does not leak through the seal. Check the fluid level.

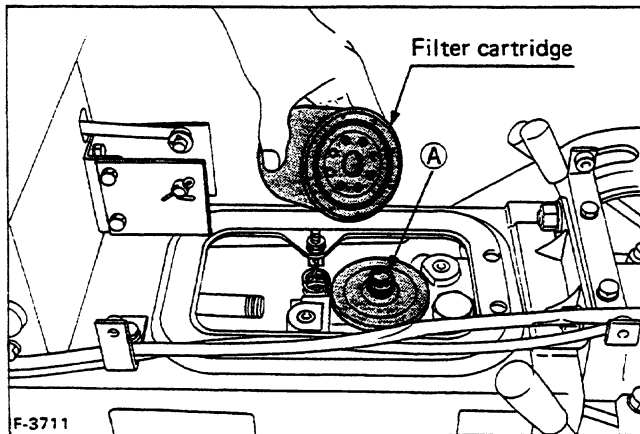

[IMPORTANT]

- (1) To prevent serious damage to the hydraulic system, the replacement filter must be a highly efficient, 10 μ m filter. Use only a genuine KUBOTA filter or its equivalent.
- (2) When using the auxiliary hydraulics, replace the transmission oil filter cartridge after initial 50 service hours.

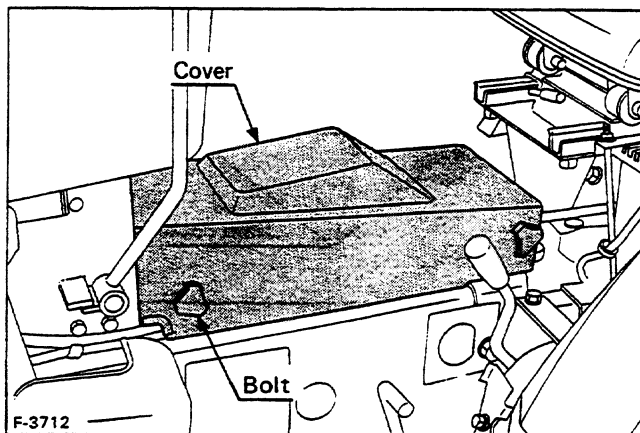

■ Cleaning Strainers

(in changing transmission fluid)

Since the fine filings in the oil could score the component parts of the hydraulic system which is precision built to withstand high pressure, the suction line ends are provided with oil strainers. When changing the transmission fluid, disassemble and rinse the oil strainers with kerosene to completely clean off filings. For reassembly, take care not to damage the parts.

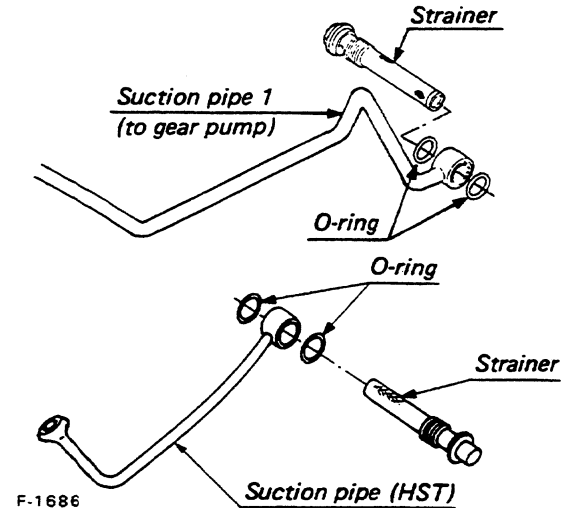

10.4 CHANGING FRONT AXLE DIFFERENTIAL CASE

(4WD) (See page 30)

Remove the drain and filling port plug. After draining, replace the drain plug and fill with new oil.

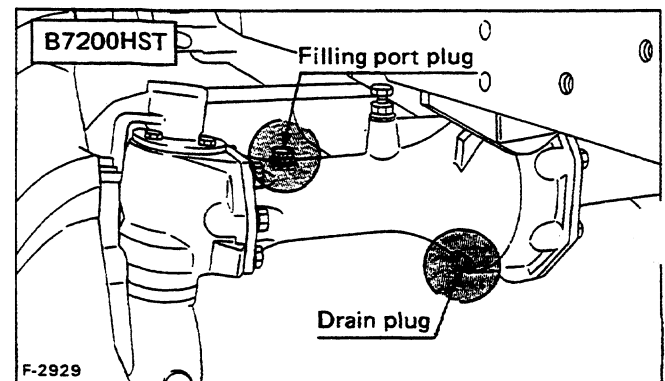
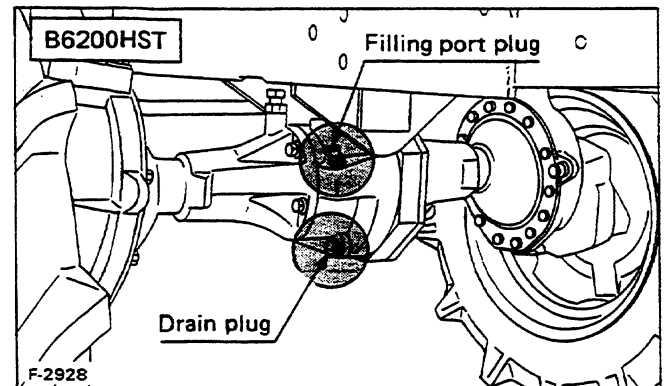

10.5 CHANGING FRONT AXLE GEAR CASE OIL

(RIGHT AND LEFT (4WD)) (See page 30)

Remove the drain and filling port plugs to drain the used oil. After draining, replace the drain plug and fill with new oil.

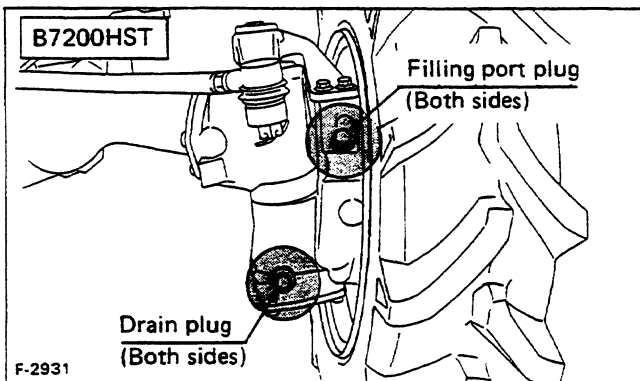
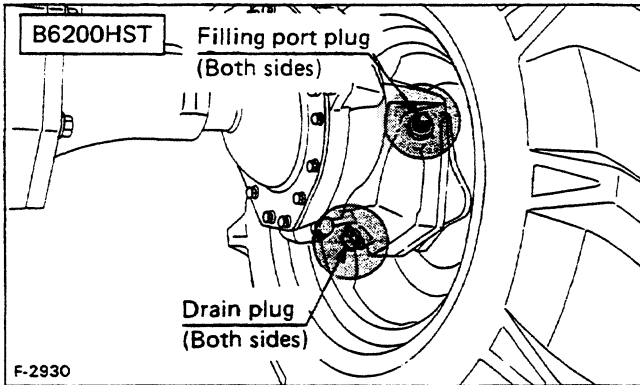

10.6 OILING AND GREASING POINTS BEFORE STARTING

Oil or grease the following points before starting.

■ King Pins (2WD) and Center Pin (2WD)

Grease the king pins and center pin with grease gun.

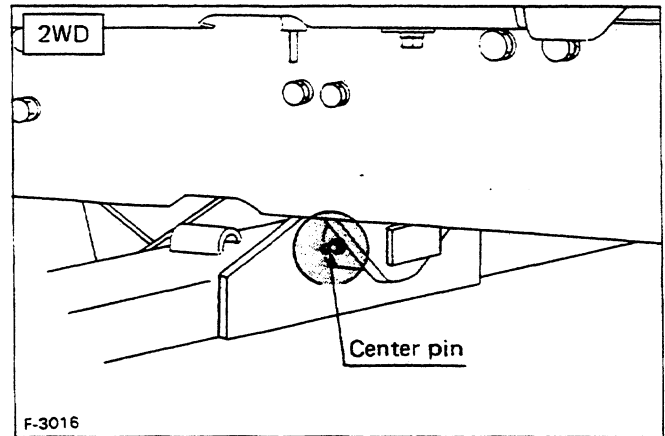
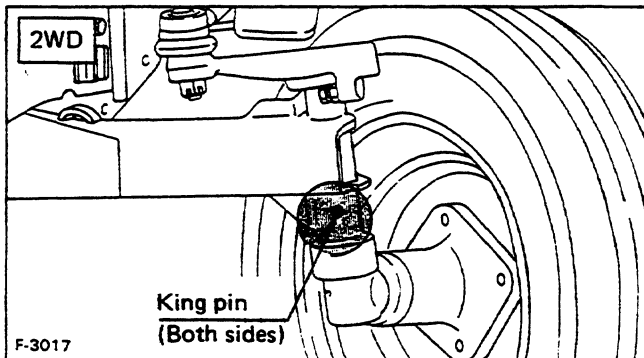

■ Pedal Shaft

Grease on both ends of the brake pedal shaft and the speed control pedal shaft.

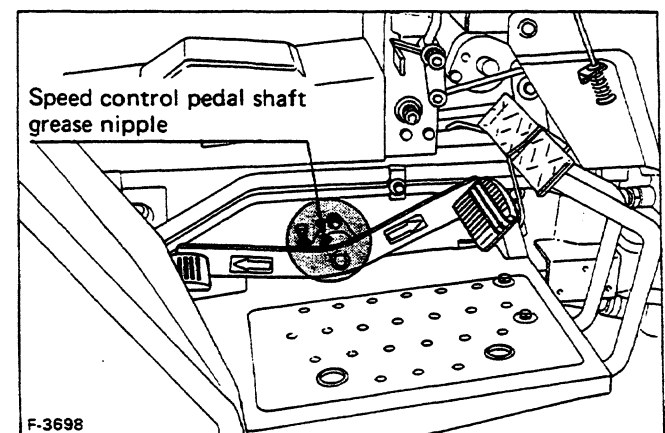
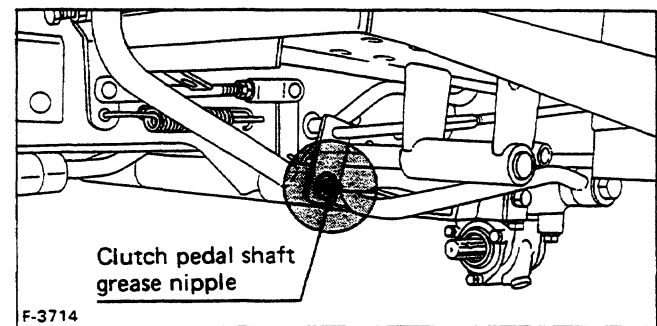
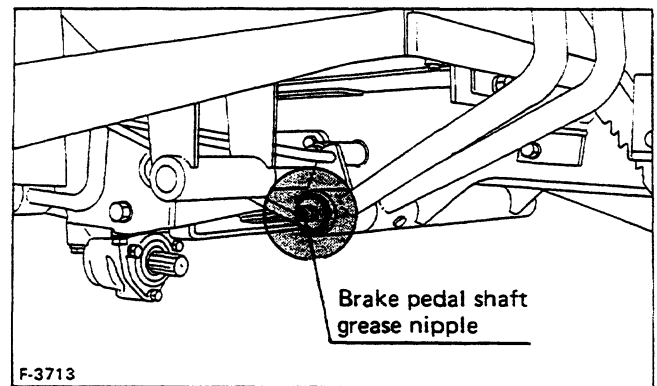

■ Clutch Release Hub

Sparingly lubricate the clutch release hub (throwout bearing). Too much grease will adversely effect the clutch performance.

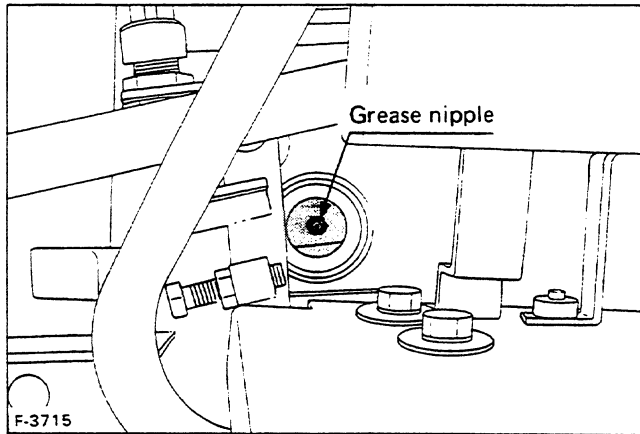

■ Interlock Rod (2WD)

Oil or grease the interlock rod and sliding holder.

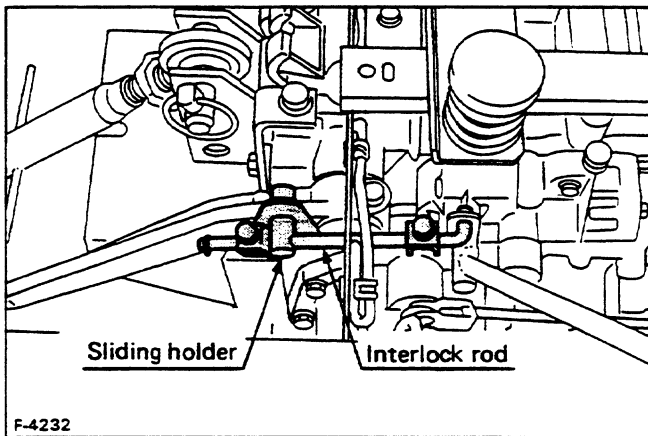

■ Seat Adjuster

Apply the grease on the surface of sliding guide.

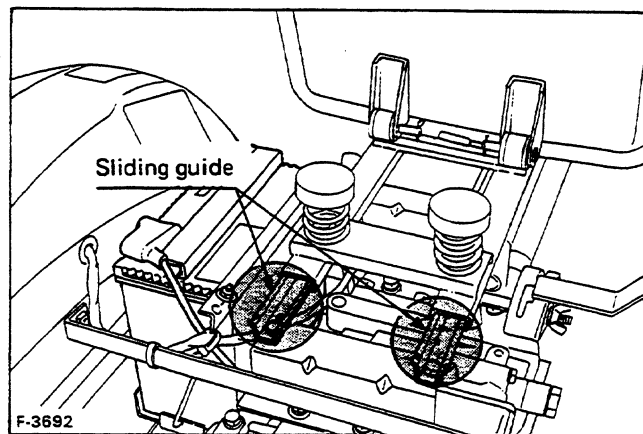

10.7 RADIATOR



CAUTION:

- Do not remove radiator filler cap until coolant temperature is below its boiling point. Then loosen cap slightly to the stop to relieve any excess pressure before removing cap completely.

■ Checking, Replenishing and Changing Coolant

- Remove the radiator pressure cap and check to see that the coolant level is just below the port. If low, add clean water and anti-freeze.

Prescribed quantity	2.8 ℓ (3.0 U.S.qts.)
---------------------	----------------------

IMPORTANT:

- Use clean, fresh water and anti-freeze to fill the radiator.
- Securely tighten the radiator cap.

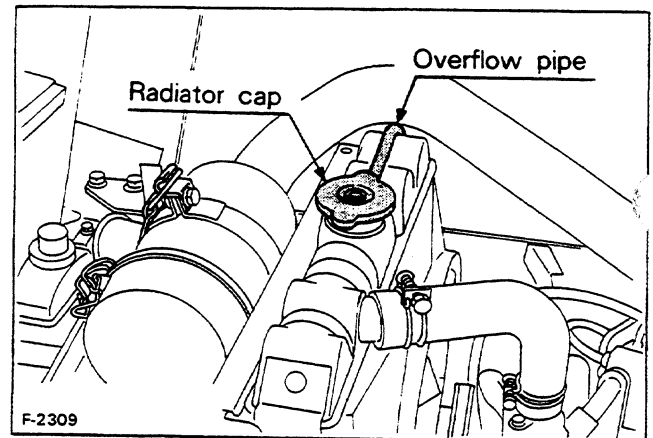

- To drain the used coolant, open the radiator drain cock and remove radiator cap. The radiator cap must be removed to completely drain the radiator.

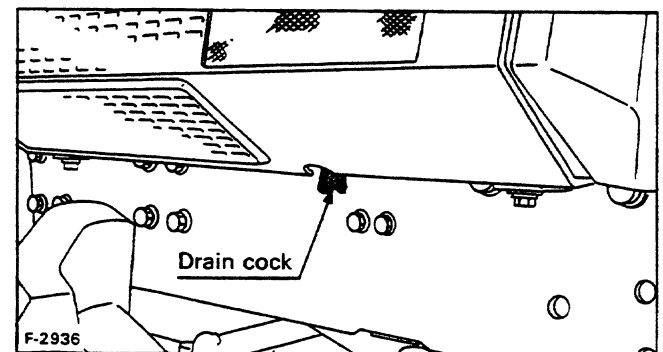

- Be sure to close the pressure cap securely. If the cap is loose or improperly closed, water may leak out and engine could overheat.

- (5) Radiator should be filled with 50/50 parts of anti-freeze and water at all times as recommended by the anti-freeze manufacturer. The anti-freeze contains a corrosion inhibitor and will allow a higher operating temperature in the radiator during the hot season.
- (6) Don't use an anti-freeze and scale inhibitor at the same time.

■ Checking Radiator Hose

Checking radiator hose clamp tightness is prescribed every 150 service hours or every 6 months, whichever occurs first.

- (1) If the clamp is loose, apply a slight coat of oil and securely retighten.
- (2) The radiator hose is made of rubber and tends to age. It should be changed when worn. Also change the clamp and securely tighten.

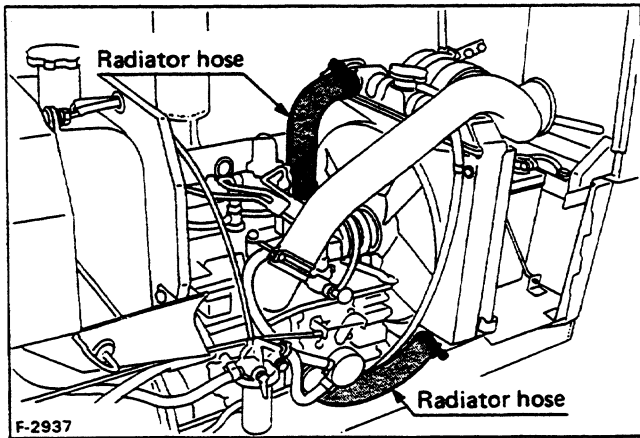

■ Kubota Scale Inhibitor No. 11

- (1) The Kubota Scale Inhibitor No. 11 or equivalent prevents scale formation in the coolant. Scale which builds up in either hard or soft water, sharply reduces cooling efficiency.
- (2) The Scale Inhibitor is effective for 3 months so a complete change of coolant must be done every 3 months.

■ Remedying Water Leakage

- (1) A small water leak can be eliminated with the Kubota Radiator Cement No. 40 or equivalent.
- (2) If water leakage should become excessive, consult your local dealer.

■ Cleaning Cooling System

- (1) The water cooling system should be cleaned on the following occasions:
 - Every 500 service hours
 - When adding an anti-freeze solution.
- (2) When cleaning the water cooling system, the Kubota Scale Inhibitor No. 20 or equivalent is recommended to effectively wash away the scale built-up.

■ Anti-Freeze

If the cooling water freezes, the engine cylinder and radiator may crack. In cold weather before the temperature drops below 0°C (32°F), drain out the water or add a proper amount of anti-freeze when the tractor is shut down.

- (1) There are two types of anti-freeze solutions, permanent type (PT) and semi-permanent type (SPT). For the Kubota Engine, be sure to use the permanent type.
- (2) When anti-freeze is used for the first time, drain and flush the cooling system completely.
- (3) Radiator should be filled with 50/50 parts of anti-freeze and water solution as recommended by the anti-freeze manufacturer. The anti-freeze contains a corrosion inhibitor and will allow a higher operating temperature in the radiator during the hot season.
- (4) Mix the anti-freeze and the water, then pour the mixture into the radiator.
- (5) When the coolant mixed with anti-freeze decreases due to evaporation, replenish with water only. If loss has been due to leaking, refill with water and anti-freeze mixture with the same mix ratio as the original preparation.
- (6) Anti-freeze solutions absorb moisture, so be sure to securely close the container after use.
- (7) Anti-freeze and water should be changed every year.
- (8) Do not use an anti-freeze and a scale inhibitor at the same time. This may cause sludge to form, adversely affecting the engine parts.

■ Checking and Cleaning Radiator and Oil Cooler

Daily or every 5 hours of operation, check to be sure the radiator net, radiator core and oil cooler core are clean.

Dirt or chaff to the radiator net, radiator core, or oil cooler core decrease cooling performance.

(1) In that case, detach the net and remove all the foreign materials from them.

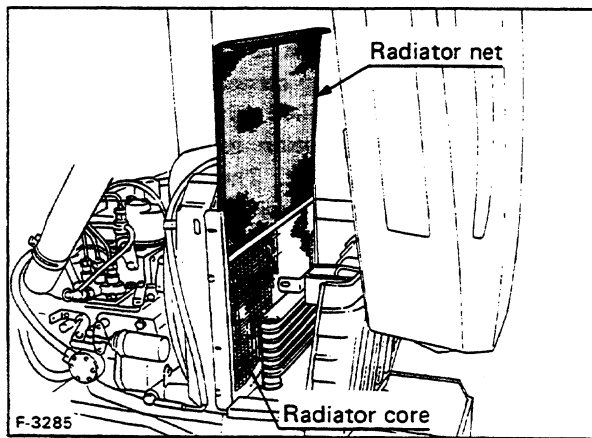
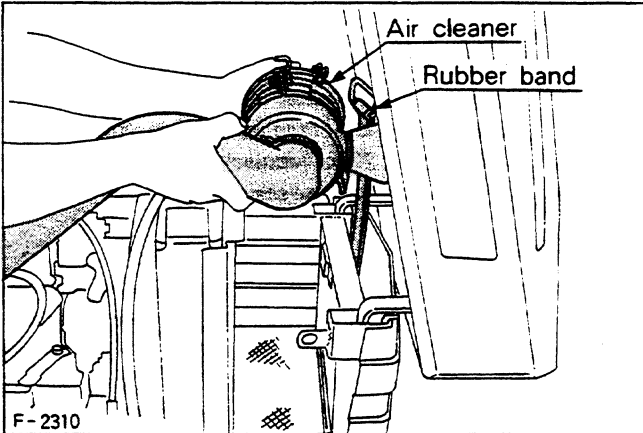

- (2) Remove the dust from between the fins and the tube.
- (3) Tighten the fan drive belt as necessary. For instructions, refer to page 42.
- (4) If scale forms in the tube, clean with KUBOTA scale inhibitor or equivalent.

Note: The front grille may be tilted forward for easy removal.

To remove the front grille, disconnect the spring and lift the grille up and away from the tractor.

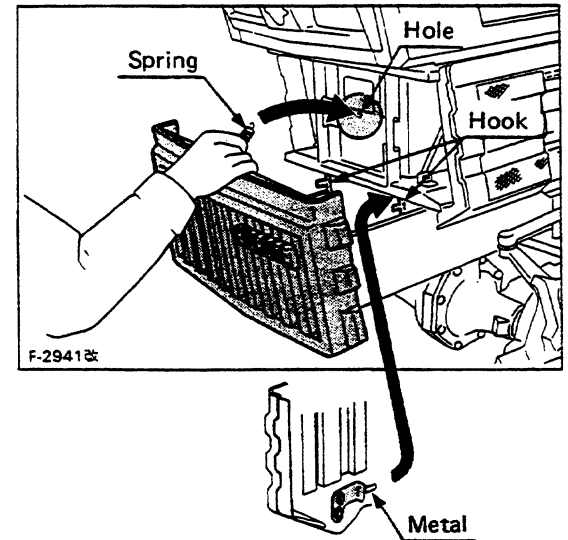
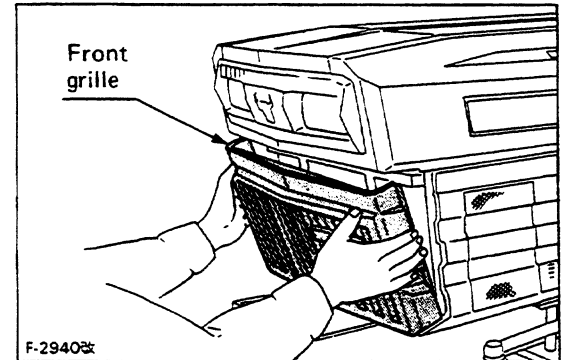

10.8 AIR CLEANER

- (1) The air cleaner uses a dry element, never apply oil.
- (2) Do not let dust build up to more than the half level in the dust cup. Detach the dust cup and clean out the dust — normally once a week, but everyday if working conditions are especially dusty.
- (3) Do not touch the filter element except in cases where cleaning is required.
- (4) When cleaning the element, refer to the instructions attached.
- (5) If the element is stained with carbon or oil, replace the filter.
- (6) Change the element once yearly or after every sixth washing, whichever ever comes first.

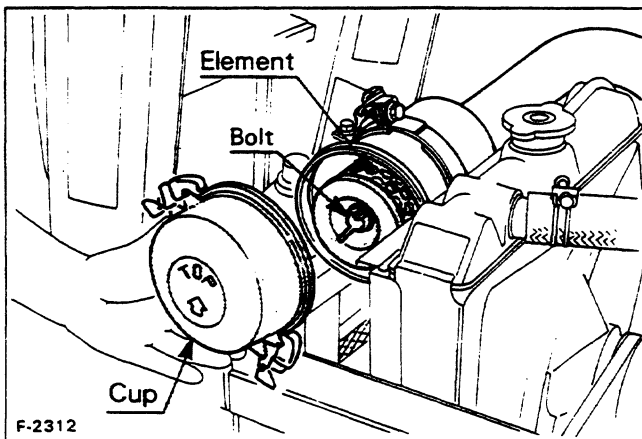

IMPORTANT:

- (1) Be sure to refit the dust cup with the arrow  (on the right) upright. If the dust cup is improperly fitted, dust passes by the dust cup and directly adheres to the element.
- (2) Do not run the engine with filter element removed.

10.9 CLEANING AIR FILTER ELEMENT

- (1) To clean the element, use clean dry compressed air on the inside of the element.
Air pressure at the nozzle must not exceed 205 kPa (2.1 kgf/cm²; 30 psi).
Maintain reasonable distance between the nozzle and the filter.
- (2) To wash the element, use KUBOTA Filter cleaner, Donaldson ND-1500 Filter Cleaner or its equivalent, which is especially effective on oily and soot-laden filters. Follow instructions that are supplied with the filter cleaner.

10.10 BATTERY



CAUTION:

- Never remove the battery cap while the engine is running.
Keep electrolyte away from eyes, hands and clothes. If you are spattered with it, flush it away completely with water.

Mishandling the battery shortens the service life and adds to maintenance costs. Be sure to handle it correctly so that it will develop its full potential performance.

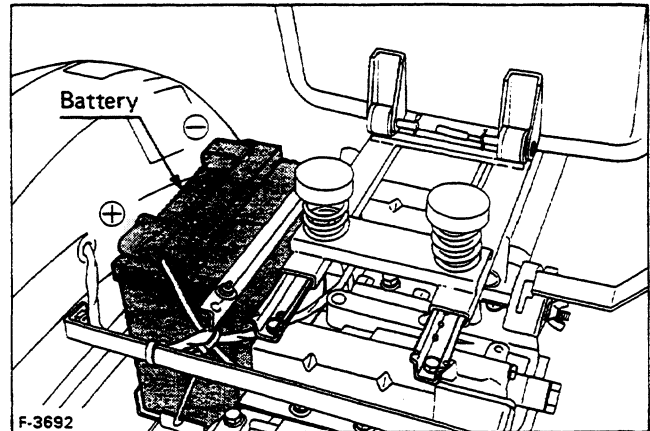

CAUTION:

- After the battery is activated, hydrogen and oxygen gases in the battery are very explosive. Keep open sparks and flames away from the battery at all times, especially when charging the battery.

- (1) If the battery is weak, the engine is difficult to start and the lamps become dim. It is important to check the battery daily and recharge before trouble occurs.
- (2) The water in the electrolyte evaporates during recharging. Liquid shortage damages the battery and excessive liquid spills over and damages the tractor body. If low, be sure to fill up the battery with distilled water.

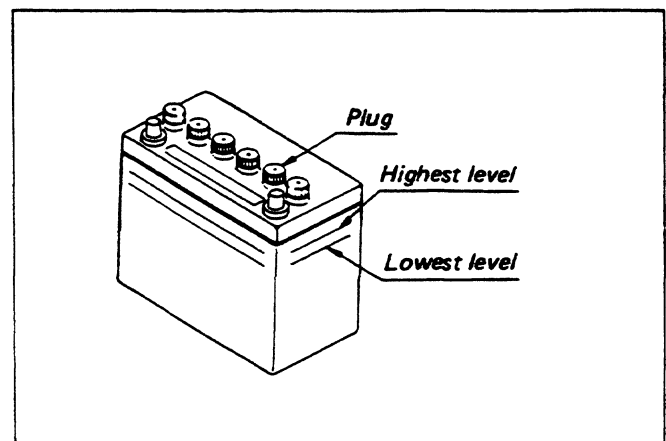

- (3) To slow charge the battery connect the battery positive terminal to the charger positive terminal and the negative to the negative, then recharge in the standard fashion.
- (4) A boost charge is only for emergencies. It will partially charge the battery at a high rate and in a short time. When using a boost-charged battery, it is necessary to recharge the battery as early as possible after the operation has been finished. Failure to do this will extremely affect the service life due to overdischarge.

**CAUTION:**

- To avoid accidental short circuit, be sure to attach the positive cable to the positive terminal before the ground cable is attached to the negative terminal.

IMPORTANT:

- If the tractor is to be operated for a short time without battery (using a slave battery for starting), do not, under any circumstances, interrupt the circuit by switching off the key switch before stopping the engine by means of fuel pump shut off cable. Use additional current (lights) while engine is running. Insulate terminal of battery cable before starting by means of slave battery. If this advice is disregarded, damage to alternator and regulator may result.

Directions for Storage

- (1) When shutting down the tractor for long periods of time, remove the battery from the tractor, adjust the electrolyte to the proper level and store in a dry place out of direct sunlight.
- (2) The battery self-discharges even while it is stored. Recharge it once a month in hot seasons and once every two months in cold seasons.

IMPORTANT:

- The tractor has been shipped with dry-type battery. Your dealer will fill it with electrolyte and charge it for initial use.

Charging Dry Type Battery

- (1) Remove vent plugs and discard temporary sealing boards and tapes.
- (2) Fill each cell with electrolyte having a specific gravity given in Table 1 up to highest level marked on the battery case side.

Table 1

	AIR TEMPERATURES	
	TEMPERATE Ordinarily below 20°C (68°F)	TROPICAL Frequently above 20°C (68°F)
sp.gr. of Electrolyte for Filling	1.260	1.240
sp.gr. of Electrolyte when fully charged	1.260 to 1.275	1.240 to 1.255

- (3) After standing 2 or 3 hours correct the electrolyte to former level.
- (4) Connect positive terminal (+) of battery, with positive terminal of D.C. charging unit, and negative terminal (-) with negative terminal.
- (5) Batteries are preferably charged by current shown in Table 2. Keep vent plugs removed during charging.

Table 2

TYPE	Volts (V)	Number of plate per cell	Capacity at 20 H.R (A.H)	Volume of Electrolyte (ℓ)	Norm. Charging Rate (A)
50B24L	12	13	45	2.8	4.5

- (6) Check temperature of electrolyte, if it reaches 40°C (105°F) lower the charging rate. When temperature is too high, reduce charging rate and charge for a proportionately longer period.
- (7) If the tractor is stored after original charge, periodically recharge as shown below:

Table 3

Period of storage from manufactured (months)	Refreshing charge (hours)
0 - 6	about 3~5 hours
6 - 12	10
over 12	30

A battery is fully charged when the cell are all gassing freely and the specific gravity ceases to rise for three consecutive readings taken at hour intervals. Specific gravity shall then be adjusted to that shown in Table 1.

- (8) Check electrolyte level two hours after charging is finished and correct it if necessary by adding distilled water.

11. ADJUSTMENTS



CAUTION:

- When making adjustments, park the tractor on flat ground and apply the parking brake.

11.1 FAN DRIVE BELT

If the fan drive belt becomes loose, the engine may over-heat.

Check the belt tension as shown below.

To adjust, loosen the adjusting bolt and tighten the tension bolt to stretch the belt. After adjustment, securely tighten the adjusting bolt.

Moderate belt tension:

The belt should deflect approx. 10 mm (0.4 in.) when the center of the belt is depressed with a finger pressure of 98N (10 kgf, 22 lbs.).

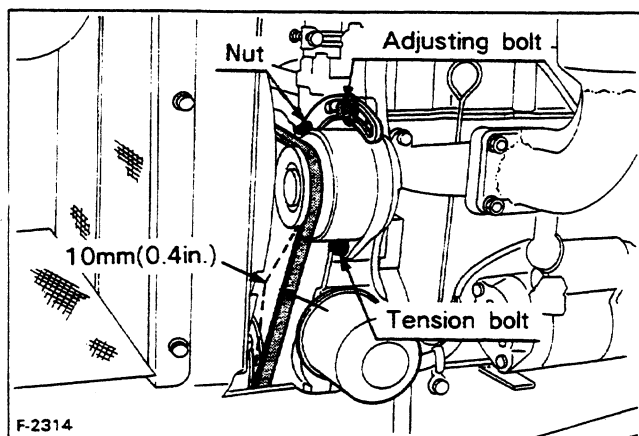

11.2 CLUTCH

Moderate clutch free travel ranges from 20 to 30 mm (0.8 to 1.2 in.).

If the clutch becomes difficult to disengage or pedal free travel decreases, adjust the length of the clutch rod after removing the pin. When the clutch is difficult to disengage, shorten the rod. When the clutch free travel is too little, extend the rod.

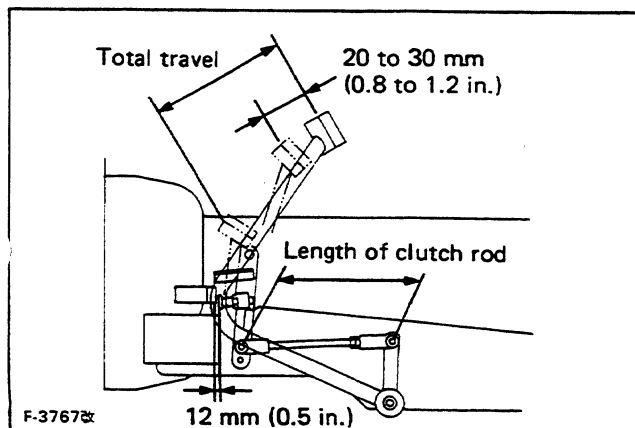

11.3 BRAKE

If brake pedal free travel becomes too great or travel varies too greatly between the right and left pedals, loosen the turnbuckle lock nut and turn the turnbuckle in the desired direction until the proper pedal free travel is achieved. Moderate right and left pedal free travel ranges from 20 to 30 mm (0.8 to 1.2 in.). After adjustment, interlock the right and left brake pedals and finally tighten the lock nut securely.

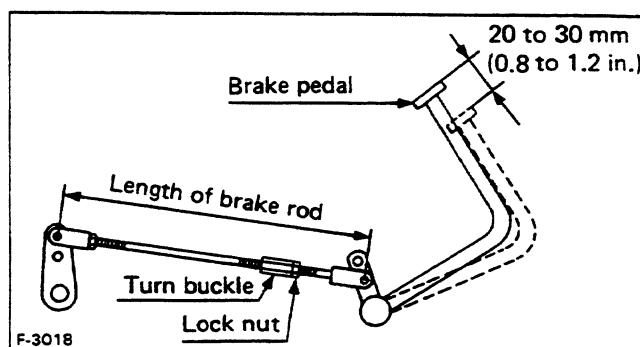

11.4 STEERING WHEEL

Moderate steering wheel play is 5 to 30 mm (0.2 to 1.2 in.). If excessive, consult KUBOTA dealers.

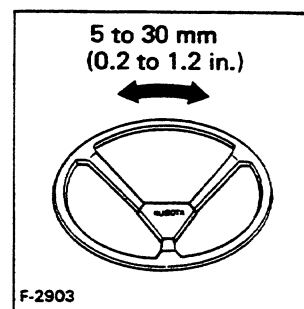

12. TROUBLESHOOTING

12.1 ENGINE TROUBLESHOOTING

■ When engine is difficult to start

Cause	Countermeasures
Fuel is thick and doesn't flow	<ul style="list-style-type: none"> * Check the fuel oil tank and fuel oil filter. * Remove water, dirt and other impurities * As all fuel oil will be filtered by the filter, if there should be water or other foreign matters on the filter, replace the filter. * See your KUBOTA dealer.
Air or water mixed in fuel system	<ul style="list-style-type: none"> * If air is in the fuel filter or injection lines, the fuel pump will not work properly. To attain proper fuel injection pressure, check carefully for loosened fuel lines, cap nut, etc. * Loosen air vent screws atop fuel filter and fuel injection pump to eliminate all the air in the fuel oil system.
Thick carbon deposits on orifice of injection nozzle.	<ul style="list-style-type: none"> * This is caused when water or dirt is mixed in the fuel. Clean the nozzle injection piece, being careful not to damage the orifice. * Check to see if nozzle is working properly or not. If not, install a new nozzle. * See your KUBOTA dealer.
Valve clearance is incorrect	<ul style="list-style-type: none"> * Adjust valve clearance. * See your KUBOTA dealer.
Leaking valves	<ul style="list-style-type: none"> * Grind valve. * See your KUBOTA dealer.
Fuel injection timing is incorrect	<ul style="list-style-type: none"> * Adjust injection timing * See your KUBOTA dealer.
Engine oil becomes thick in cold weather and engine cranks slow	<ul style="list-style-type: none"> * Change grade of oil according to the weather (temperature).
Low compression	<ul style="list-style-type: none"> * Bad valve or excessive wear of rings, pistons and liners cause insufficient compression. Replace with new parts.
Battery is discharged and the engine will not crank.	<ul style="list-style-type: none"> * Charge battery. * Use decompression device. * In winter, always remove battery from tractor, charge fully and keep indoors. Install in tractor at time of use.

■ When output is insufficient

Cause	Countermeasures
Air cleaner is dirty Fuel filter is dirty	<ul style="list-style-type: none"> * Clean the element every 100-200 hours of operation.
Carbon around orifice of nozzle piece	<ul style="list-style-type: none"> * Clean orifice and needle valve, being very carefully not to damage the nozzle orifice. * Check nozzle. * If defective, replace with new parts. * See your KUBOTA dealer.
Compression is insufficient. Leaking valves	<ul style="list-style-type: none"> * Bad valve and excessive wear of rings, pistons and liners cause insufficient compression. Replace with new parts. * Grind valves.
Fuel is insufficient	<ul style="list-style-type: none"> * Check fuel system.
Overheating of moving parts	<ul style="list-style-type: none"> * Check lube oil system. * Check to see if lube oil filter is working properly. * Filter screens or elements deposited with impurities would cause poor lubrication. Clean screens. * Check to see if bearing clearance are within factory specs. * Check engine timing.
Valves out of adjustment	<ul style="list-style-type: none"> * Adjust to proper valve clearance. * See your KUBOTA dealer.
Fuel injection pressure is incorrect	<ul style="list-style-type: none"> * Adjust to proper pressure. * See your KUBOTA dealer.

■ When color of exhaust is not clear.

See your KUBOTA dealer.

■ When engine suddenly stops

Cause	Countermeasures
Leak of fuel	<ul style="list-style-type: none"> * Check the fuel tank and refill if necessary. * Also check the fuel system for air or leaks
Bad nozzle	<ul style="list-style-type: none"> * If necessary, replace with a new nozzle.
Moving parts are overheated due to shortage of lube oil or improper lubrication	<ul style="list-style-type: none"> * Check amount of engine oil with dipstick. * Check lubricating oil system. * Check to see if element inside the lubricating oil filter (2) has become old and clogged. If necessary, replace with new element. * Check to see if the engine bearing clearances is within factory specs.

IMPORTANT:

- When the engine has suddenly stopped, decompress the engine by the decompression knob and turn the engine lightly by pulling on the fan belt. If the engine turns easily without abnormalities, the cause of the trouble is usually lack of fuel or bad nozzle.

■ When engine must be stopped immediately

Cause	Countermeasures
Speed suddenly decreases or increases	<ul style="list-style-type: none"> * Check the adjustments and timing of injection and the fuel system.
Unusual sound is heard suddenly.	<ul style="list-style-type: none"> * Check all moving parts carefully.
Color of exhaust suddenly turns dark	<ul style="list-style-type: none"> * Check the fuel injection system, especially the fuel injection nozzle.
Bearing parts are overheated	<ul style="list-style-type: none"> * Check the lubricating system.
Oil light lights up during operation	<ul style="list-style-type: none"> * Check lubricating system. * Check to see if the engine bearing clearances are within factory specs. * Check the function of the regulating valve inside the oil filter (2). * Check pressure switch * Check filter base gasket

12.2 TRACTOR TROUBLESHOOTING

■ When 3 point hitch does not move

Cause	Countermeasure
Transmission strainer is clogged	<ul style="list-style-type: none"> * Clean the strainer
3 point hitch does not lower	<ul style="list-style-type: none"> * Check the hydraulic adjusting bolt

■ Tractor operation is not smooth

Cause	Countermeasure
Hydrostatic transmission fluid is insufficient.	<ul style="list-style-type: none"> * Replenish oil.
Filter is clogged	<ul style="list-style-type: none"> * Replace the filter.
Strainer is clogged	<ul style="list-style-type: none"> * Clean the strainer.

■ Tractor does not move while engine is running

Cause	Countermeasure
High-low gear shift lever is at neutral.	<ul style="list-style-type: none"> * Check the high-low gear shift lever.
Parking brake is on.	<ul style="list-style-type: none"> * Release the parking brake.
Transmission fluid is insufficient.	<ul style="list-style-type: none"> * Replenish oil.

■ Tractor moves when speed control pedal is not depressed. (Engine is operated.)

Cause	Countermeasure
Hydrostatic lever linkage is not correctly adjusted.	<ul style="list-style-type: none"> * Ask your dealer for hydrostatic lever linkage adjustment or pressure adjustment.

12.3 BATTERY TROUBLESHOOTING

Condition of Battery	Cause	Countermeasure	Precaution
Starter does not function	Key is not "ON" Battery over-used until light becomes dim Charging of battery neglected Defective Alternator rectifier. Dirty or corroded terminal contacts Bad brushes, armature or field Life of battery expired	Turn key "ON" Charge for long period by ordinary charging method until specific gravity of 1.26 is reached. Repair Alternator and replace defective rectifier. Charge battery well. Wash terminal with hot water and tighten well. Replace Replace battery	Do not overuse the battery and charge before fully discharged. (Refrain from overdischarging) Check Alternator rectifier. Keep terminals clean, tighten well and grease to prevent corrosion.
From beginning, starter does not function, and lights become dim quickly.	Battery not charged well	Charge battery for long period by ordinary charging method.	Battery must be serviced properly before initial use.
Low electrolyte level.	Battery used with shortage of electrolyte. Battery over-used. Moreover, charging was neglected. (Refrain from over-discharging.) Defective Alternator rectifier. Defective terminal contacts causing sulphation of electrodes.	Add distilled water and charge battery Charge for long period. Check Alternator and rectifier and charge for long period by ordinary charging method.	Make routine checks of electrolyte Do not overuse the battery and fully discharge. Make routine checks of terminals, to make sure they are clean and tight.
Battery cannot be charged.	The current of the Alternator during operation is too high causing plates to drop, warp or short-circuit. Life of battery expired.	Decrease the charging current of Alternator. Exchange defective battery. Exchange battery.	Check charging current of Alternator.
Corrosion of terminals severe.	Current of the Alternator during operation is too large.	Clean scale from terminals and tighten well. Adjust charging current of Alternator.	Keep terminals clean and well tightened. Apply grease to prevent corrosion. Check charging current of Alternator.
Electrolyte decrease rapidly	Over heating due to overcharging. Storage battery cracked or has small holes.	Check charging output. Replace battery	Secure battery to tractor so it would not move.

13. LONG-TERM STORAGE



CAUTION:

- (1) To avoid the danger of exhaust-fume poisoning, do not operate the engine in a closed building without proper ventilation.
- (2) When storing, remove the key from the key switch to avoid unauthorized persons from operating the tractor and getting injured.

When the tractor will not be operated for two or three months or longer, clean the tractor and perform the following treatment before storage.

- (1) Repair the parts as needed.
- (2) Check nuts and bolts, tighten as necessary.
- (3) Apply grease or engine oil to the parts most likely to rust.
- (4) Remove any ballast weight.
- (5) Inflate the tires to a little above the standard pressure levels.
- (6) Change the engine oil and run the engine for five minutes so that the oil circulates through the entire system.
- (7) Stop the engine by fully pulling the engine stop knob.
- (8) Drain the radiator. Flush and refill with new coolant.
- (9) Lock the clutch pedal with the provided wooden block.

If the tractor is stored for a long period with the clutch left engaged, the clutch disc may rust, rendering it inoperative.

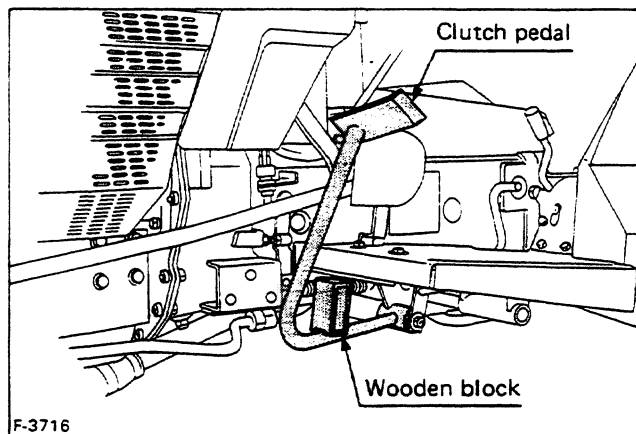

- (10) Lower the implement to the ground.
- (11) Remove the battery from the tractor, recharge it, adjust the electrolyte to the proper level, and store in a dry place out of direct sunlight.
- (12) The battery runs down over time even while in storage. Recharge it once a month in hot seasons and once every two months in cold seasons.
- (13) Store the tractor where dry and sheltered from rain. Further cover the tractor with a tarpaulin.
- (14) When leaving the tractor outdoors, protect the muffler from the rain.

IMPORTANT:

- To clean the tractor stop the engine. If you must clean the tractor with the engine going, utmost care should be taken not to allow water to enter the air cleaner. Engine trouble may occur if water enters the engine.

14. OPTIONS (consult your KUBOTA Dealer)

■ SMV (Slow Moving Vehicle) Emblem

Recommended to forewarn overtaking traffic of tractor's presence.

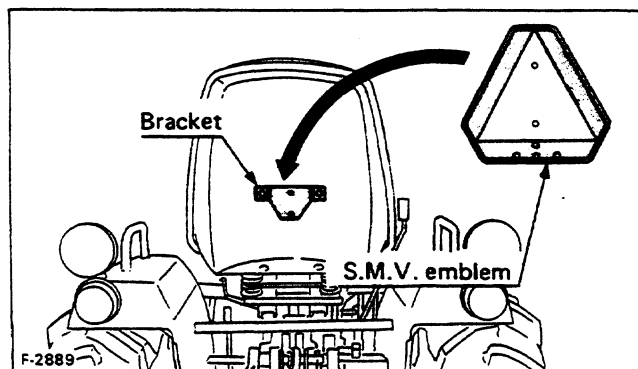

■ Drawbar

See page 22

15. LUBRICANT SPECIFICATIONS

■ Engine Oil

Oil used in the engine should have an American Petroleum Institute (API) / SAE Classification of service CC or CD. The chart below shows the correct weight oil to be used at various temperature conditions:

ENGINE OIL VISCOSITY CHART

Below 0°C (32°F)	SAE 10W or 10W-30
0°~ 25°C (32°~77°F)	SAE 20 or 10W-30
Above 25°C (77°F)	SAE 30 or 10W-30

■ Others

Power steering	Multi-grade transmission fluid (Same as transmission oil)
Front Wheel Bearings [2WD]	SAE lithum based grease
Chassis grease fittings	Multipurpose type grease
Front Wheel Drive Unit [4WD]	SAE 80 or 90 weight gear oil

■ Transmission Oil

The oil used to lubricate the transmission is also used as hydraulic fluid. To insure proper operation of the hydraulic system and complete lubrication of the transmission, it is important that a multi-grade transmission fluid be used in this system. We recommend the use of Kubota UDT fluid for optimum protection and performance.

Also the following are recommended oils, by brand name, that may be used in the transmission hydraulic system.

Maker	Brand Name
Atlantic Richfield (Arco)	Arco Tractor Fluid
Chevron	Tractor Hydraulic Fluid
Exxon	Torque Fluid 56
Penzoil	Hydra-Trans and Wet Br.
Phillips	H.T.Fluid
Shell	Donax TD,TT,TM
Texaco	T.D.H.Oil
Union	Hydraulic / Tractor Fluid
Gulf	Universal Fluid 425,350
Mobil	Mobil Fluid 423,350

KUBOTA LUBRICANTS

THE BEST CHOICE SINCE BUYING YOUR KUBOTA

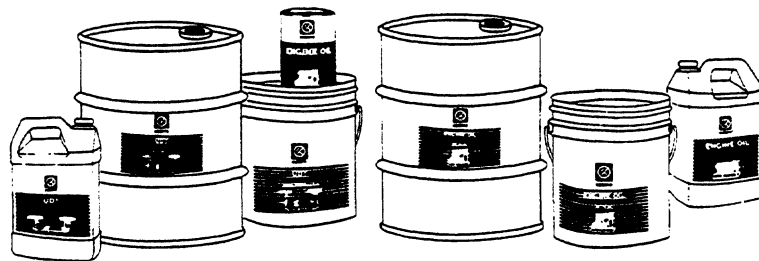

When you think of Kubota diesel tractors, you think of quality, performance and service. Now you can also think of Kubota lubricants.

Now, Kubota offers a lubricant line to use with all the Kubota tractors from 10 to 85 PTO horsepower. The Kubota lubricant line consists of a 15W-40 or 10W-30 engine oil and a universal transdraulic fluid called "UDT." A variety of sizes are available to meet your small and larger needs, in 1 quart, 2 gallon, 5 gallon and 55 gallon containers.

Next time you need to pour it on, pour it in with Kubota lubricants.

Kubota lubricants, tractor tough quality.



Nothing like it on earth.™

16. WIRING DIAGRAM

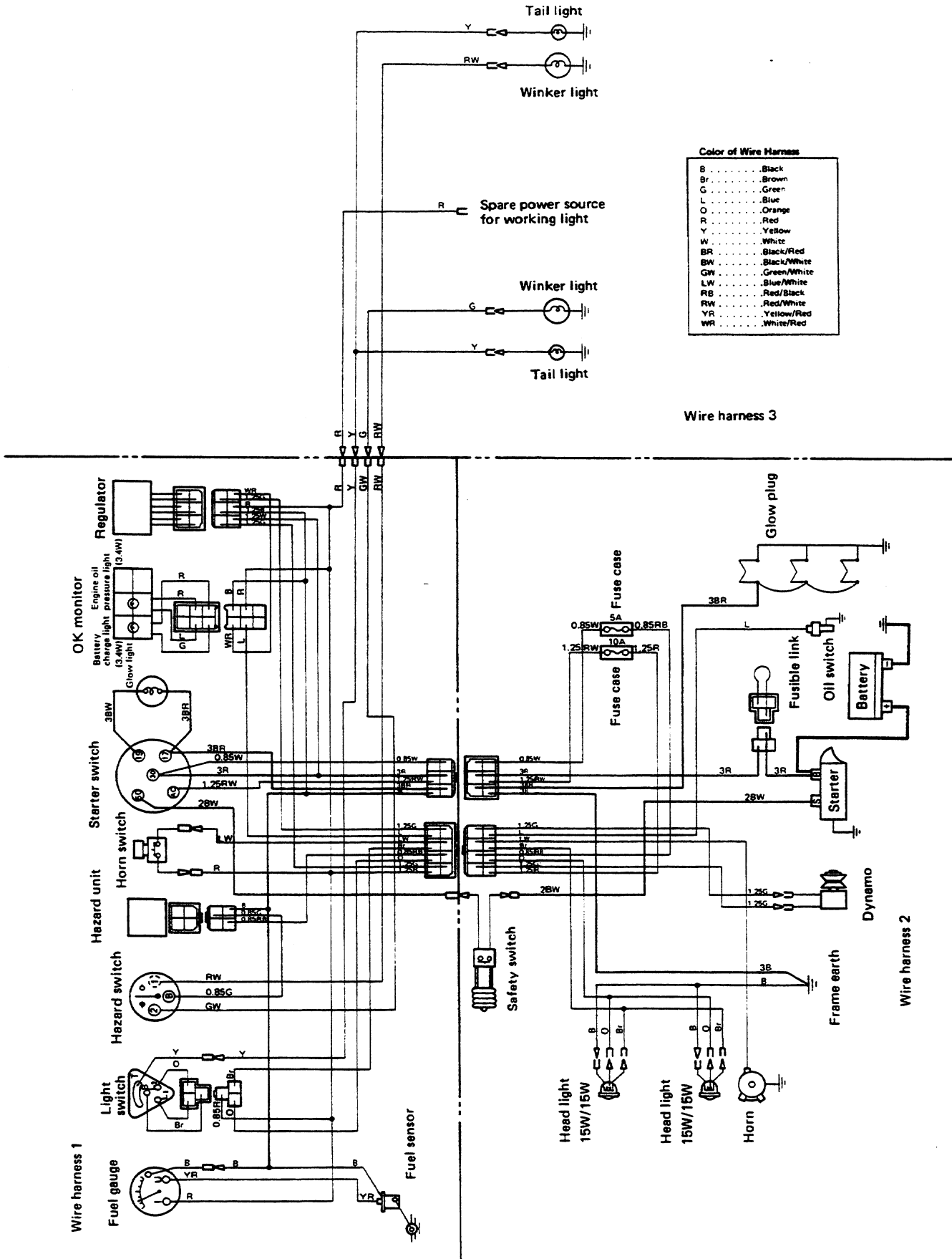

INDEX

A		L	
Air cleaner	40	Lifting rod, adjusting	22
Anti-freeze	38	Light switch	13
B		Long-term storage	46
Ballast	25	Lubricants	30
Battery	40	Lubricant specifications	47
Battery troubleshooting	45	M	
Bleeding the fuel line	32	Maintenance check list	31
Brake adjustment	42	O	
Brake pedals	17	Oiling and greasing points before starting	36
C		Operating the engine	27
Charging dry type battery	41	Operating the PTO	3
Check chains, adjustment	22	Operating the tractor	2, 28
Clutch adjustment	42	P	
Clutch release hub	37	Parking brake lever	18
Controls	15	PTO speed gear shift lever	17
D		Position control	19
Daily check	30	R	
Decompression knob	14	Radiator	37
Differential lock pedal	18, 29	S	
Drawbar	22	Safe PTO operation	3
Driving the tractor on the road	2	Safe 3-point hitch operation	3
E		Safety	1-5
Engine oil	33	Safety labels	
Engine oil filter cartridge change	34	Seat, adjustable sliding	
Engine oil pressure light	14, 29	Serial number	o
Engine stop knob	16	Servicing of tractor	6
Engine troubleshooting	43	Specifications	7
F		Speed control pedal	16
Fan drive belt	42	Speed set device	16
Front axle differential case oil, changing	35	Speed, traveling	9
Front axle gear case oil, changing	36	Starting engine	27
Front wheel drive lever	17	Steering wheel	42
Fuel	29, 32	Stopping engine	27
Fuel filter bowl, cleaning	33	Switches	13
Fuel line, checking	32	T	
Fuses	15	Three-point hitch	22
G		Throttle lever	16
Glow plug indicator	13	Tires	25
H		Toe-in	26
Hazard light switch	13	Tractor troubleshooting	44
High-low gear shift lever	16	Transmission fluid	34
Horn button (optional)	14	Transmission strainer	35
Hour meter	14	Traveling speeds	9
Hydraulic control lever	19	Treads	24
Hydraulic block type outlet	21	U	
I		Using 3-point hitch	3
Implement limitations	10, 11	W	
Instrument panel	13	Wheel hub	25
J		Wiring diagram	48
Jump starting	4		
K			
Key switch	13		

Kubota®

KUBOTA TRACTOR CORPORATION

CORPORATE OFFICE: 3401 DEL AMO BOULEVARD, TORRANCE, CA 90503
WESTERN DIVISION: 6665 Hardaway Road, Stockton, CA 95215 • (209) 931-5051
CENTRAL DIVISION: 14855 F.A.A. Blvd., Fort Worth, TX 76155 • (817) 571-0900
NORTHERN DIVISION: 2626 Port Road, Columbus, OH 43217 • (614) 492-1100
SOUTHEAST DIVISION: 1025 North Brook Parkway, Suwanee, GA 30174 • (770) 995-8855



PRINTED IN U.S.A.

April 2002

Code No. 67061-62914

